

BELL SYSTEM PRACTICES
Private Branch Exchange
Installation and Maintenance

SECTION B702.002
Issue 1, 6-30-27
Standard

NO. 35-C TEST SET

1. GENERAL:

1.1 This section describes the No. 35-C test set used for testing relays and other apparatus on a current flow basis. Typical testing circuits are described and the apparatus arrangements shown for the application of the set to different kinds of circuit arrangements.

2. GENERAL DESCRIPTION OF CIRCUIT AND APPARATUS:

2.1 The No. 35-C test set is a testing device by means of which the current to an external circuit can be regulated, and is used primarily for making electrical checks of relays and other apparatus for which current flow requirements are specified.

2.2 The principal elements of the set consist of a millimeter in series with an adjustable resistance for regulating the strength of the current. In addition to these elements, there are keys and switches for setting up the required circuit arrangements, and jacks and binding posts for supplying battery and ground to the set and for connecting the test circuit to the apparatus under test.

2.3 The switching apparatus, which is exposed to view when the lid of the box is removed, is shown in Figure 7. Two rheostats are mounted in the rear of the box, and in front of

these is a panel which mounts the milammeter, miscellaneous keys, switches, etc. The circuit arrangement is shown in Figure 9.

2.4 The milammeter is a model No. 267 Weston instrument having 3 ranges, 0-.015, 0-.075 and 0-.750 ampere, and is equipped with a knife edge needle and a mirror. The scale of the meter has an inner and an outer band of lines each of which contains 75 lines. These two bands of lines are located with respect to each other so that each line in one band of lines bisects the space between two adjacent lines in the other band of lines. Hence for the 0-.015 ampere range the distance between two adjacent lines, that is, one line on the outer band and the next line on the inner band, will represent .015 ampere divided by 150 or .0001 ampere. In like manner the distance between two adjacent lines for the 0-.075 range will be .0005 ampere, and for the 0-.750 range .005 ampere. The change of ranges is made by the key designated MIL-AMPS, the designations 15, 75 and 750 indicating the position of the key for each scale range. This key is non-locking in the position designated 15 and 75 so as to safeguard the instrument as much as possible against excessive current flow.

2.5 Referring to the test circuit, Figure 9, it will be noted that one side of the milammeter is connected to the black rheostat, which is equipped with four slides; that is, the test set is arranged so that four different and independent current flow values may be set up at one time. Two of these slides are wired directly through telegraph keys 1 and 2 to slides of the red rheostat and the other two are connected through other resistances, external jacks and telegraph keys 3 and 4 to the other two slides of the red rheostat. The slides are numbered 1, 2, 3 and 4 to indicate with which telegraph key each is associated. Each telegraph key is equipped with a short-circuiting switch so that, if desired, a closed circuit can be maintained without holding the key depressed.

2.6 The two rheostats are mounted end to end at the rear of the panel. The long rheostat equipped with the black slides

is of the slide wire coil type having, with all turns cut in, a minimum resistance of 1,150 ohms. The resistance is approximately 2 ohms per turn. The short rheostat equipped with the red slides is a drum made up of an assembly of circular insulated contact rings which are connected to spool resistances of 1,000 ohms each, giving a range of 0 to 28,000 ohms in 1,000-ohm steps.

2.7 Each of the circuits through telegraph keys 3 and 4 passes through a series of No. 38-type resistances totaling 500,000 ohms and the normally closed contacts of a cut-off jack through which the circuit may be connected to a remote control key or other external circuit, as, for example, some machine controlled interrupter. The resistances can be cut out by means of a series of single pole, double throw knife type switches. Each switch has a designation for each position which indicates the amount of resistance in the circuit. The front set of three switches designated 3 is associated with telegraph key 3 and the back set of switches designated 4 is associated with telegraph key 4.

2.8 In addition to the knife switches just mentioned, there is a knife switch designated G which is effective only when the BATT & GRD-CO key is operated. If the latter key is operated and the G switch is open, a metallic circuit is closed through the milammeter, but if the G switch is operated toward the position marked GRD, ground is connected to one side of the milammeter. Another knife switch, designated L, is provided to control the sleeve condition of the T&R jack. With this switch normal there is a 500-ohm resistance in the sleeve circuit. When the switch is operated in the direction marked 10, a 10-ohm resistance is placed in parallel with the 500 ohms and when operated in the direction marked 500 & LAMP, a local circuit is closed through the signal lamp. The signal lamp can be connected in the circuit in various ways to indicate contact closure.

2.9 The reverse key, designated REV, is used to reverse

the leads to the apparatus under test by reversing the tip and ring leads of the T&R jack.

2.10 Each of the leads to the millammeter and rheostat is equipped with a No. 24-B $\frac{1}{2}$ -ampere fuse. These fuses are mounted on the panel in the rear of the millammeter so as to be readily replaceable.

2.11 Connection to the test set is made through the jacks and binding posts, shown in Figure 7. The jacks are grouped under two designations, TEST and SIGNAL. Except for the two jacks designated EXT KEY, either jack under each designation can be used interchangeably, depending upon the type of plug employed, the top row taking the No. 110 and the bottom the No. 109 plug. The EXT KEY jacks each take the No. 110 plug.

2.12 The EXT KEY jacks are designated 3-R and 4-W. The numbers 3 and 4 indicate with which telegraph key each jack is associated and the R and W designations are provided to enable the maintenance man to properly associate the red and white plugs of the No. 803 cord which is used for external control. The red plug should be inserted in the 3-R jack and the white plug in the 4-W jack.

2.13 The S jack is provided, primarily, for testing cut-off relays in subscribers' line circuits in central offices, but it can be used also for testing the sleeve relays in other circuits.

3. TYPICAL TEST ARRANGEMENTS:

3.1 Figures 1 to 4, inclusive, show typical test arrangements which can be obtained with the No. 35-C test set. The figures show how the patching is to be done and which keys must be operated for each arrangement. The dotted wiring in each case indicates the part of the test set wiring which is not used. It should be understood, however, that other test arrangements are possible, using the various jacks, binding posts and test cords in different combinations. If connection is made to the

contacts or winding terminals of a relay, the No. 891 cord equipped with the proper connecting tools may be used. If the relay is bridged by a jack, the jack may be patched to the test circuit by means of a No. 740 cord. If the relay is in the tip or ring of a cord circuit, the cord can be inserted directly in the T&R jack. The No. 891 cord equipped with the proper connecting tools may be used to pick up battery and ground at the most convenient place and supply it to the test set. Battery and ground may also be supplied in some cases by plugging a common battery switchboard cord directly into the test BATT & GRD jack.

3.2 Figure 1 shows the test arrangement where the relay has neither battery nor ground connected to its winding. The current through the relay may be reversed by operating the REV key. This is a necessary requirement when testing polarized relays.

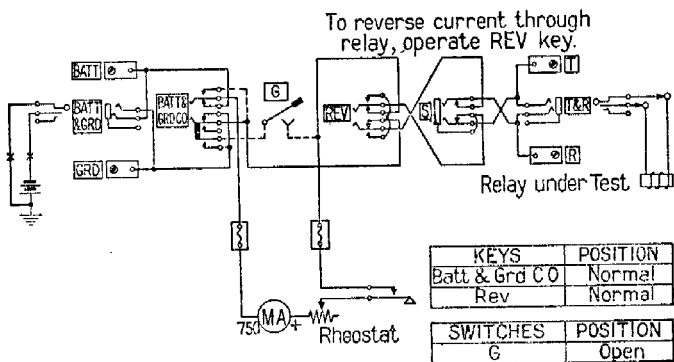

Fig. 1—Neither Battery Nor Ground on Relay Winding

3.3 Figure 2 shows the test arrangement where one side of the winding of the relay is grounded. It should be noted that the REV key must be normal if the tip clip of the patch-

ing cord is connected to the relay or operated if the ring clip is connected to the relay.

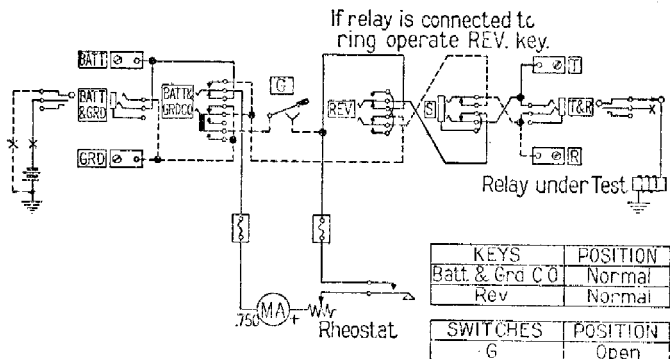

Fig. 2—Ground on Relay Winding

3.4 Figure 3 shows the test arrangement where one side of the winding of the relay is connected to battery. It should be noted that the REV key must be normal if the ring clip of the patching cord is connected to the relay or operated if the tip clip is connected to the relay.

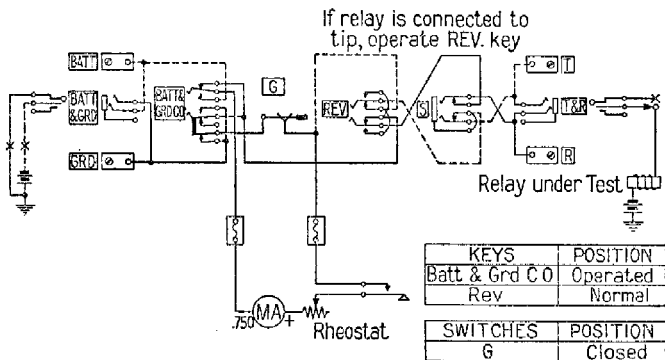

Fig. 3—Battery on Relay Winding

3.5 A modification of test arrangements 2 and 3 consists in employing the unused clip of the patching cord to pick up battery or ground as required, and then using the test arrangement shown in Figure 4.

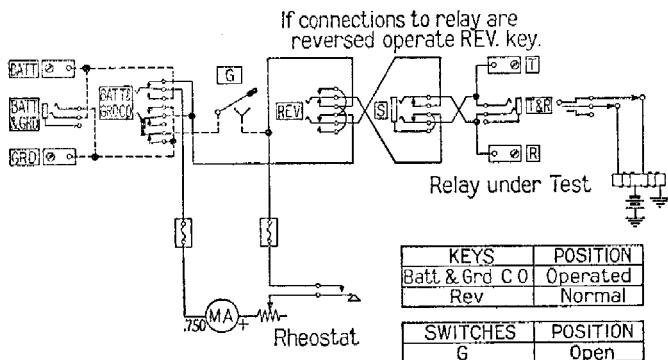
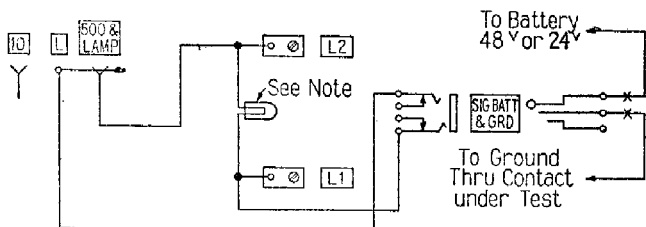

Fig. 4—Battery and Ground on Relay Winding

3.6 Figure 4 shows the test arrangement for a relay with both battery and ground connected to it.



— NOTE —

Choose type of lamp to be used in accordance with the following :-

Voltage across lamp	Type of Lamp
12	2-F
18	2-W
24	2-G
48	2-T

Fig. 5—Using Lamp Signal to Indicate Contact Closure

3.7 Figure 5 shows a typical arrangement for using the lamp signal to indicate contact closure. Because of the flexibility of this feature, other arrangements are possible, and in each particular case the most convenient one should be used.

4. METHOD OF OPERATION:

4.1 The first step in the use of the No. 35-C test set consists in ascertaining what test arrangement is most suitable for the particular apparatus under test. After making sure that all of the short-circuiting switches of the telegraph keys are opened and the slides of both rheostats are in their extreme right position, the test set can be patched and the keys and switches operated as required by the test arrangement to be used. These precautions should be observed in order to avoid injuring the milammeter.

4.2 The short-circuiting switch of one of the telegraph keys should be operated and the corresponding slides moved until the desired current is obtained. Care should be taken not to operate MIL-AMPS key until the reading of the milammeter indicates that the current is less than the full scale reading of the range to which transfer is to be made.

4.3 The minimum current for which circuits 1 and 2 can be used is slightly less than .002 ampere on 48 volts or .001 ampere on 24 volts. For lower current values it is necessary to use circuits 3 and 4 with which are associated the additional resistances controlled by the knife switches designated 3 and 4. The maximum resistance of the rheostat should be in the

circuit before operating these knife switches so as to guard as much as possible against injury to the milammeter.

4.4 When manual remote control is desired, the No. 803 cord should be patched to jacks 3-R and 4-W. When mechanical remote control is desired, one of these jacks should be patched to the jack wired to the mechanical controlling device. Wherever possible the current value should be adjusted with the external controlling device in the circuit.

4.5 Below are listed cords which may be used in connection with the No. 35-C test set for private branch exchange work. These cords are shown in Figure 6.

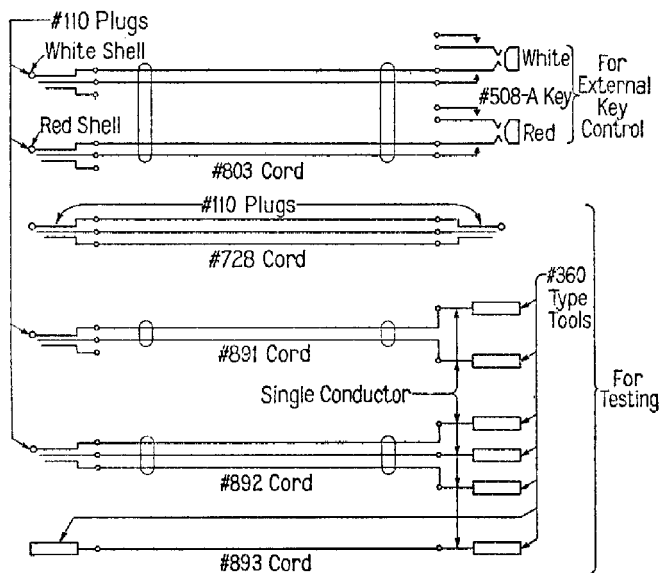

Fig. 6—Cords Used in Connection with No. 35-C Test Set

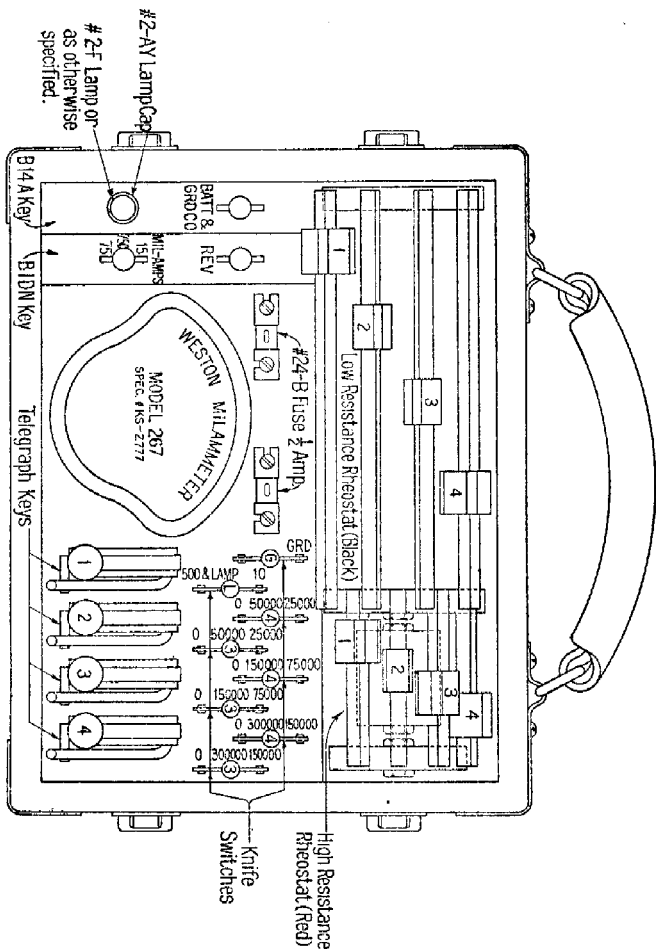

Fig. 7—No. 35-C Test Set—Apparatus Arrangement

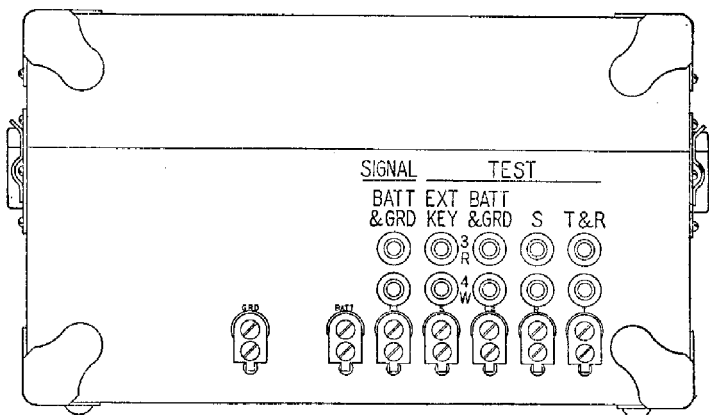

Fig. 8—No. 35-C Test Set—Front View

4.6 The No. 360 type tool shown in Figure 6 is designed for connecting the cords to various other tools used in making connection with apparatus contacts and terminals, and is provided with a colored sleeve to indicate the cord conductor with which it is used:

Code	Conductor	Color
360-A	Sleeve	Red
360-B	Ring	Black
360-C	Tip	White

4.7 The following listed tools have been standardized for use with the No. 360 type tools. Other tools will be added later.

- (a) No. 361 tool; used for connecting to winding terminals of E, H and R type relays from the front.
- (b) No. 364 tool; a spade terminal for connecting to apparatus terminals equipped with screw fasteners.
- (c) No. 365 tool; a connector of the "suspender clip" type.
- (d) No. 357 tool; a spring contact clip and insulator.

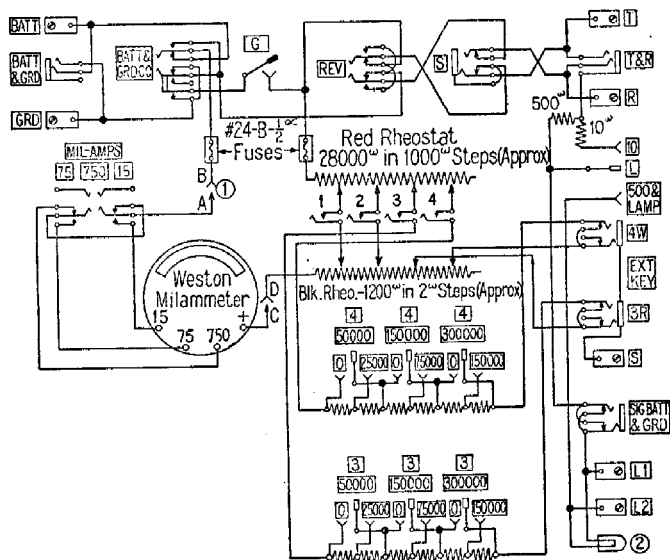

NOTES

- ① The milammeter is wired in the set as shown. This arrangement is that required for use in offices having POSITIVE side of battery grounded. For use in offices having NEGATIVE side of battery grounded reverse connections to milammeter by connecting A to D and B to C.
- ② This lamp may be used to indicate contact closure. Choose type of lamp to be used in accordance with the following:

Voltage across lamp	Type of lamp
12	2-F
18	2-W
24	2-G
48	2-T

Fig. 9—No. 35-C Test Set—Circuit Arrangement