

# Winterthur Portfolio

## A Journal of American Material Culture

*Volume 51, Number 4 Winter 2017*



TCI Library: [www.telephonecollectors.info](http://www.telephonecollectors.info)

PUBLISHED FOR THE WINTERTHUR MUSEUM

# Winterthur Portfolio

*A Journal of American Material Culture*

*Winterthur Portfolio* fosters knowledge of the North American past by publishing articles on material culture and the historical contexts within which artifacts developed. The journal presents scholarship that critically engages art history, history, geography, ethnology, archaeology, anthropology, folklife studies, and literature. We invite articles that are analytical and synthetic rather than descriptive, and we encourage interdisciplinary studies that integrate artifacts into a cultural framework.

Authors should submit three hard copies of their double-spaced manuscript for initial evaluation and double-blind peer review. Black-and-white or color printouts of digital images or good-quality photocopies of film images are sufficient for review. Clear, sharp images are essential. Figure captions should be complete and in *Winterthur Portfolio* style. Request current guidelines from the managing editor.

Manuscript acceptance policy: While it is our policy to require the assignment of copyright on articles, we do not usually request assignment of copyright for other contributions. Although the copyright to such a contribution may remain with the author, it is understood that, in return for publication, the journal has the nonexclusive right to publish the contribution and the continuing right, without limit, to include the contribution as part of any reprinting of the issue or volume of the journal in which the issue or volume may be reproduced by the publisher or by its licensed agencies. It is also understood that, upon submission and acceptance, the author will abide by the journal's editorial style. Correspondence concerning contributions should be addressed to Amy C. Earls, Winterthur Portfolio, Winterthur, Delaware 19735. Tel. (302) 888-4615, email [aearyl@winterthur.org](mailto:aearyl@winterthur.org). Business correspondence should be addressed to The University of Chicago Press, Journal Division, P. O. Box 37005, Chicago, Illinois 60637.

*Winterthur Portfolio* is indexed in *America: History and Life*, *Architectural Periodicals Index*, *Art Index*, *Historical Abstracts*, *MLA International Bibliography*, and *Biography of the History of Art*.

## Katherine C. Grier Prize

Winterthur Museum, Garden & Library has announced the winner of the Katherine C. Grier Prize for the best recent article in *Winterthur Portfolio: A Journal of American Material Culture*. Dr. Joanna Cohen received the 2015 prize for "Promoting Pleasure as Political Economy: The Transformation of American Advertising, 1800 to 1850," *Winterthur Portfolio* Volume 48, Numbers 2/3, Summer/Autumn 2014. Winterthur's Academic Programs Department awards the prize every two years, in the amount of \$1,000, for the best article in the most recent six issues of *Winterthur Portfolio*. See the webpage at <http://www.winterthur.org/?p=655> for more information.

---

**Catharine Dann Roeber**  
Executive Editor

**Amy C. Earls**  
Managing Editor

**Ashley Rye-Kopec**  
Book Review Editor

---

## Editorial Board

**Annamarie Adams**, McGill University  
**Bobbye Tigerman**, Los Angeles County Museum of Art  
**Wendy Bellion**, University of Delaware  
**Jennifer Greenhill**, University of Southern California

**William D. Moore**, Boston University  
**Susan Parrish**, University of Michigan  
**Zara Anishanslin**, University of Delaware  
**Timothy Shannon**, Gettysburg College

*Winterthur Portfolio* (ISSN 0084-0416) is published three times a year for the Henry Francis du Pont Winterthur Museum by The University of Chicago Press, Journals Division, 1427 E. 60<sup>th</sup> St., Chicago, Illinois 60637.

# Editor's Introduction

*Catharine Dann Roeber*

CREATING is more often than not a product of collaboration, and material culture scholars certainly acknowledge this basic point. Constrained by word limits for museum labels and the desire for clear and precise arguments in academic essays, however, we may slip into glorifying the creative genius of single makers while distilling away the nuances of design and production. This issue of *Winterthur Portfolio* challenges narratives of solitary creators by adding complexity to house and telephone histories. In "From the Collection: The Transformation of Montmorenci," Rosemary T. Krill and Maria V. Shevzov employ the concept of "itinerary" to uncover three episodes or "stops" of creation and re-creation of historic architecture from a North Carolina house now partially housed in the Winterthur museum rooms. In the process, the skills and talents of craftspeople both enslaved and free become central to the history of the plaster decoration and woodwork that is now enjoyed as a tourist attraction in a museum setting. The architecture, in turn, is framed not as the spoils of a wealthy planter or collector alone, but as the material realization of multiple negotiations over time. Similarly, in "Henry Dreyfuss and Bell Telephones," Russell A. Flinchum and Ralph O. Meyer reveal a more complex history in the design of the Western Electric model 302 Bell telephone than credited by most design historians (including the authors themselves!). Through detailed object analysis, attention to corporate records, and new oral histories the authors uncover a team of designers who each contributed substantially to this and later Bell Telephone designs. George R. Lum, Robert H. Hose, and Donald M. Genaro may not be household names or the subject of celebration and study like Henry Dreyfuss, but they are no less integral to the design of some of the most notable material elements of twentieth-century living: phones. As these articles and the reviews in this issue attest, making and modifying the material world is rarely

a solitary process. If we are to better understand the past, we will do well to expand our definition of creator and our consideration of all those whose talents and skills helped build our material world.

We welcome you to contribute your own creations to *Winterthur Portfolio* and actively seek new interdisciplinary scholarship on American material culture. Please see our call for contributions below and contact Amy Earls or Catharine Dann Roeber with inquiries about submissions.

*Winterthur Portfolio: A Journal of American Material Culture* encourages submissions from fresh faces and seasoned scholars. As a premier journal dedicated to interdisciplinary material culture scholarship, we seek manuscripts that bring new insights and spark conversations about the material world in the Americas. *Winterthur Portfolio* upholds its long-standing dedication to comparative scholarship that may not find a home in discipline-specific journals by encouraging innovative content and approaches from decorative arts, art, architecture, literature, and more. Submissions that explore theory, pedagogy, and other issues in American material culture studies and that represent new voices are particularly welcome.

Successful submissions should contain a strong material culture focus and a clear thesis statement. The text should engage with the relevant secondary literature, and figures should contribute to, not merely illustrate, the argument.

As a journal that appears both in print and digital format, *Winterthur Portfolio* welcomes traditional manuscripts as well as innovative textual, graphic, and video content. Manuscripts in print format should be at least 8,000 words (30–45 double-spaced pages) and may contain up to 20–25 images, preferably in full color. *Winterthur Portfolio* reimburses authors of accepted manuscripts for reasonable photo permission costs. Examples of published articles are available at <http://www.journals.uchicago.edu/toc/wp/2015/49/1>. For inquiries and questions, please contact Executive Editor Catharine Dann Roeber ([croeber@winterthur.org](mailto:croeber@winterthur.org)), or Managing Editor Amy Earls ([aeearls@winterthur.org](mailto:aeearls@winterthur.org)).

# Henry Dreyfuss and Bell Telephones

*Russell A. Flinchum and Ralph O. Meyer*

*Using insider sources from the Dreyfuss firm, hands-on examination of artifacts, and recently available digital resources, the authors dispel three myths about Henry Dreyfuss's work for the Bell System, proving that (1) previously uncredited Bell System designer George Lum, not Dreyfuss, designed the Western Electric model 302, (2) an Ericsson phone did not inspire the 302 design, and (3) Dreyfuss did not use anthropometric measurements in his telephone work. The colorful and occasionally tension-filled history of Dreyfuss and associates' design of the 500, Princess, Trimline, and some Design Line phones clarifies human and technical aspects of his design process.*

**H**ENRY DREYFUSS was well established in 1930 when he began his association with the Bell System, so it is natural to picture the classic 1937 Bell telephone as his iconic achievement. What's wrong with this picture (fig. 1) is that Henry Dreyfuss did not design the 302 model telephone for which he is celebrated. George Renwick Lum did. Both of the present authors made this

Russell A. Flinchum is associate professor of design history at North Carolina State University and author of *Henry Dreyfuss, Industrial Designer: The Man in the Brown Suit* (Smithsonian Institution, 1997). He worked as an archivist in the Dreyfuss firm in the early 1990s. Ralph O. Meyer is a physicist and author of *Old-Time Telephones!* (McGraw-Hill, 1995; Schiffer, 2005). He has owned, studied, and written about Bell System telephones for more than twenty-five years.

The authors are particularly grateful to Donald Genaro, a surviving partner of Henry Dreyfuss, for his active participation in preparing this publication. We also thank Paul Fassbender of the editorial board of *Singing Wires: The Journal of Telephone Collectors International*, curator Sheldon Hochheiser of the AT&T archives, and William Meehan, a collector of art deco. These three men provided critical information that we were unable to locate. We also thank the newly reopened Gregg Museum of Art and Design at North Carolina State University, which owns many of the telephones examined here, and their photographer, Matthew Gay.

Further, we want to acknowledge the most remarkable change in the years since our earlier work: the internet. Earlier correspondence by mail and phone calls largely has been superseded today by digital communication with fellow researchers facilitated by online journals previously only accessible through on-site library use; ready access to patents via Google Patents and other services; and a blossoming international network of phone collectors and experts. For example, our ability to first examine the influence of the Jean Heiberg design and then dismiss it as unimportant to the design of the Bell System's 302 came through rapid exchanges with museum professionals and collectors in Scandinavia—unthinkable when our works were first published.

© 2017 by The Henry Francis du Pont Winterthur Museum, Inc. All rights reserved. 0084-0416/2017/5104-0001\$10.00



Fig. 1. US Forever postage stamp crediting the 1937 Western Electric 302 desk telephone design to Henry Dreyfuss, 2011. (US Postal Service.)

mistake in the past, giving full credit to Dreyfuss.<sup>1</sup> The most prominent recent appearance of the error is by Ellen Lupton, senior curator of contemporary design at Cooper Hewitt, Smithsonian Design

<sup>1</sup> Russell Flinchum, *Henry Dreyfuss, Industrial Designer: The Man in the Brown Suit* (New York: Rizzoli International Publications, 1997), 97; Ralph O. Meyer, *Old-Time Telephones! Design, History, and Restoration* (Atglen, PA: Schiffer Publishing, 2005), 77.

Table 1. Bell Telephones and Principal Design Credits

Model	Date	Principal Designer(s)
No. 302 combined base and handset	1937	George Lum (base and handset)
No. 500 standard base and handset	1949	Robert Hose (base), Henry Dreyfuss (handset)
Princess bedroom set (base only)	1959	Robert Hose
Trimline handset and 2 bases	1965	Donald Genaro (bases and handset)
Design Line (first 5 phones in the series)	1973	Donald Genaro, John McGarvey, and Gordon Sylvester

Museum.<sup>2</sup> If we try to trace the origin of the error to its source, we find that Lupton cites Flinchum, Flinchum cites Hiesinger and Marcus, and they do not cite a source for their statement.<sup>3</sup>

The story of Henry Dreyfuss telephone designs for the Bell System beginning in 1930 is full of false starts, clandestine activities, failed designs, tensions, and surprises. To build an accurate narrative, published material is dovetailed with (a) colorful descriptions of the 500's design process in unpublished contemporary notes of Dreyfuss's design engineer, Alvin Tilley; (b) lucid recollections of Donald Genaro, one of Dreyfuss's surviving partners, who participated in many of these telephone designs; and (c) examination and dimensional measurements of production specimens of all of these Bell System telephones, made by the authors to understand nuances of the Dreyfuss design process. Together, these materials reveal how members of the Dreyfuss firm applied his design practice to telephones in collaboration with Bell Telephone Laboratories designers, engineers, and managers. Design credits for telephones discussed below are summarized in table 1.

When the Bell System first approached Dreyfuss in 1929, he was well known for his design of theatrical sets, at one time having five shows running simultaneously on Broadway (fig. 2). He had studied under another luminary in that field, Norman Bel Geddes. Dreyfuss was among the most prominent of the first generation of American industrial designers. Capitalizing on this recognition, during 1929, his first year as an industrial designer, Dreyfuss engaged an impressive number of eighteen clients. The following year, this number rose to thirty-eight, including the gigantic Bell System. Of course by the



Fig. 2. Henry Dreyfuss, 1931. (Central Press Association.)

apex of his career, industrial designer Henry Dreyfuss was also known for several other spectacular successes: the New York Central's 20th Century Limited streamlined passenger trains of the 1930s and 1940s, Deere and Co. tractors and agricultural equipment from 1936 on, and the postwar S.S. *Independence* and S.S. *Constitution* ocean liners.<sup>4</sup> Further, by then Dreyfuss had two offices, a full load of fifteen clients, and about sixty employees, so he could not spend much time at a drawing board, instead relying heavily on his talented staff.

Henry Dreyfuss rapidly refined his approach to design during his career, eventually distilling it to five points—echoing perhaps Swiss-French architect Le Corbusier's "Five Points of a Modern Architecture," which would have been familiar to most in the design community by the time Dreyfuss started invoking his less strident system. The key to understanding is that these points—safety and utility, maintenance, cost, quality, and appearance—were his checklist: Dreyfuss used them to critique his firm's design work.<sup>5</sup> It is important to stress that these were not deterministic and did not constitute a road

<sup>2</sup> Ellen Lupton, *Beautiful Users: Designing for People* (New York: Princeton Architectural Press, 2014), 22.

<sup>3</sup> Kathryn B. Hiesinger and George H. Marcus, *Landmarks of Twentieth-Century Design* (New York: Abbeville Publishing Group, 1993), 121.

<sup>4</sup> Flinchum, *Henry Dreyfuss, Industrial Designer*, e.g., 38, 54, 148; Christian T. Roden, "Henry Dreyfuss Designs the Postwar Ocean Liner," *Winterthur Portfolio* 49, no. 4 (Winter 2015): 137–73.

<sup>5</sup> William Purcell said that Dreyfuss's attitude was "To hell with it if there were six [points]!" See Flinchum, *Henry Dreyfuss, Industrial Designer*, 125–26 for a more thorough discussion of the genesis of the "five points."



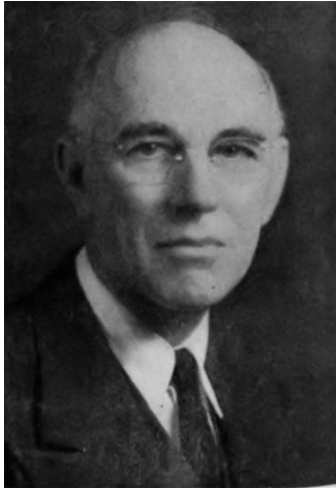

Fig. 5. George R. Lum, 1942. From "Twenty-Five-Year Service Anniversaries," *Bell Laboratories Record* 21 (January 1943): xxii.

ticulously planned design through one of his own cartoon-like sketches on a cocktail napkin, as if it had been a sudden inspiration. The youngest designers, those actually making dozens of preliminary sketches, might find them all rejected by Dreyfuss with the comment, "that's not our office." When someone finally presented a promising visual theme, Dreyfuss would encourage him to continue. This process of refinement did not place an undue creative burden on Dreyfuss but rather freed him to do what only he could do: obtain new clients and keep the current clients happy.

As for the famous anthropometric charts of Joe and Josephine showing measurements and proportions of the human male and female body that have been reproduced in countless publications, it is easily determined from publications in the office's few remaining files that wartime work created new challenges and new sources of information for Dreyfuss's orientation toward designing for people. It was only in early 1953, however, that Dreyfuss prioritized this work in a meeting with Tilley, Julian Everett, and Ann Shortess, the office's girl Friday. The first chart, a mural by Tilley, is now lost. However, an image of Josephine from 1953 survives thanks to a lantern slide Dreyfuss had made for a presentation that same year (fig. 3). Drawings of Joe and Josephine were first published in 1955 in *Designing for People* and were included in the first edition of *The Measure of Man* in 1960, which revolutionized industrial design because it was an affordable tool published with the goal of sharing these baseline data with the

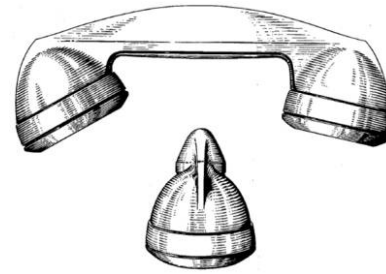

Fig. 6. Patent drawings of F-type handset, detail of figs. 1 and 4 from George R. Lum (assignor to Bell Telephone Laboratories, New York), "Design for a Hand Telephone," patent D95,915, filed 1935. (US Patent and Trademark Office.)

broadest audience possible.<sup>6</sup> It was a gift to the research community that might have been regarded as proprietary by many competing firms.

The Bell System was a monolithic regulated monopoly, a concept that is largely foreign to today's business world. This giant corporation comprised the American Telephone and Telegraph Company (AT&T) and its associated companies: Bell Telephone Laboratories (Bell Labs, for design and engineering), Western Electric (for manufacturing and supply), and twenty-one local operating companies (e.g., Illinois Bell, New Jersey Bell), all but six of which were wholly owned by AT&T.<sup>7</sup> An internal AT&T Long Lines Department handled long distance and international service in cooperation with the operating companies. The Bell System designed, manufactured, owned, and maintained all of its phones and wire infrastructure—even the wires inside subscribers' homes—with subscribers paying monthly fees. By its centennial in 1976, there was one phone for every 1.5 people in the United States, and the Bell System owned 80 percent of them. It had thus fully achieved its original goal of universal service. But the giant system was under attack for antitrust abuses, and in 1982 AT&T entered into a consent decree that broke up the company.<sup>8</sup> On January 1, 1984, the Bell System ceased to exist.

In 1929 the Bell System sought to improve the appearance of their basic telephone by engaging designers from outside of the company. Bell Labs offered thousand-dollar awards to each of ten art-

<sup>6</sup> Henry Dreyfuss, *The Measure of Man: Human Factors in Design* (New York: Whitney Library of Design, 1959).

<sup>7</sup> American Telephone and Telegraph Company, *1975 Annual Report* (New York: AT&T, 1976), 2, 9, 18.

<sup>8</sup> American Telephone and Telegraph Company, *1982 Annual Report* (New York: AT&T, 1983), 3.

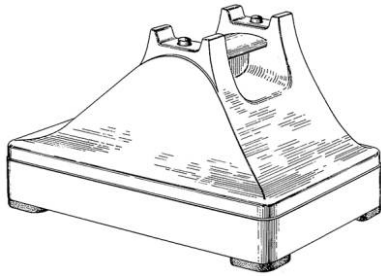

Fig. 7. Patent drawing showing handhold of 302 desk stand, detail of fig. 5 from George R. Lum (assignor to Bell Telephone Laboratories), "Desk Stand for a Hand Telephone," patent D95,765, filed 1935. (US Patent and Trademark Office.)

ists and craftsmen for their conceptions of the future appearance of the telephone.<sup>9</sup> Dreyfuss refused to participate because he thought that the telephone's appearance should be developed from the inside out, in collaboration with Bell Labs technicians, not merely as an artist's conception. The experiment with independent artists failed, and Bell Labs returned the job to in-house designers for a tune-up of the old design.

The result was the Western Electric No. 202 model shown in figure 4. Even a cursory look at this phone reveals the motivation for still further improvement of the design: cost. In the 202 and previous models, three major components were required: a handset, a desk stand for the handset, and a subset on the wall to house the large components (ringer, coil, and condenser). By making components smaller and redesigning the desk stand to house them all, huge cost savings could be realized not only in hardware but also in installation. Thus the Bell System sought a combined telephone and a brand new design.

#### The Prewar No. 302 Combined Telephone

For the so-called combined telephone, which would become known as the Western Electric No. 302 above (see fig. 1), the Bell System did not turn over design work to an outside designer. After their failed experiment of 1929, they simply hired a consultant, and the design responsibility remained in house. Perhaps because of his expressed attitude on consulta-

<sup>9</sup> Henry Dreyfuss, *Designing for People* (New York: Simon and Schuster, 1955), 102-3.



Fig. 8. Jean Heiberg, Ericsson DBH-1101 desk telephone, 1931. (Gregg Museum of Art and Design.)

tion with technicians, Henry Dreyfuss was hired as this consultant. "As a consultant to Bell Telephone Laboratories since 1930, he has had a hand in the design of almost every Bell telephone as well as related products."<sup>10</sup>

We now know that the 302 telephone was not designed by Dreyfuss. This surprising conclusion is based on consistency between the absence of claims on Dreyfuss's behalf and the presence of claims by the Bell System.

No mention of Dreyfuss has been found by the authors in prewar Bell System publications. And the 1967 statement quoted above is carefully worded to say that Dreyfuss had a hand in, rather than being the creator of, the designs. Dreyfuss was not shy about advertising his own work, however, and in fact he published records of his industrial designs from 1929 to 1957.<sup>11</sup> No mention is made in these publications of the 302 model, although the 500 and the Princess are featured (the Trimline and others were not in production until after 1957). When one of the authors of the present article (Flinchum) worked as a slide curator and archivist at Henry Dreyfuss Associates in New York for about a year (1991-92), he found no records related to the 300-series designs, in stark contrast to the numerous records related to the other telephone designs (500, Princess, Trim-

<sup>10</sup> "Adapting Products to People," *Bell Telephone Magazine* (July 1967): 18.

<sup>11</sup> See the following by Henry Dreyfuss: *10 Years of Industrial Design, 1929-1939* (New York: Henry Dreyfuss, 1939); *A Record of Industrial Designs, 1929-1946* (New York: Henry Dreyfuss, 1946); *Industrial Design: A Progress Report, 1929-1952* (New York: Henry Dreyfuss, 1952); and *Industrial Design: A Pictorial Accounting, 1929-1957* (New York: Henry Dreyfuss, 1957).

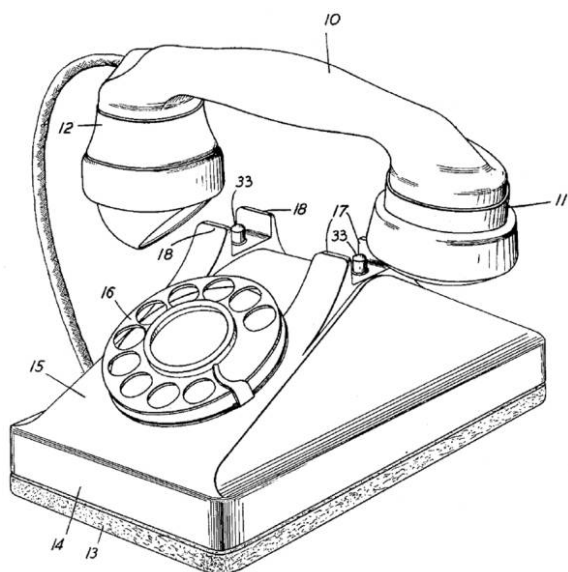

Fig. 9. Patent drawing of layout for pre-302 desk set, detail of fig. 1 from George R. Lum (assignor to Bell Telephone Laboratories), "Telephone Substation Apparatus," patent 2,008,287, filed 1932. (US Patent and Trademark Office.)

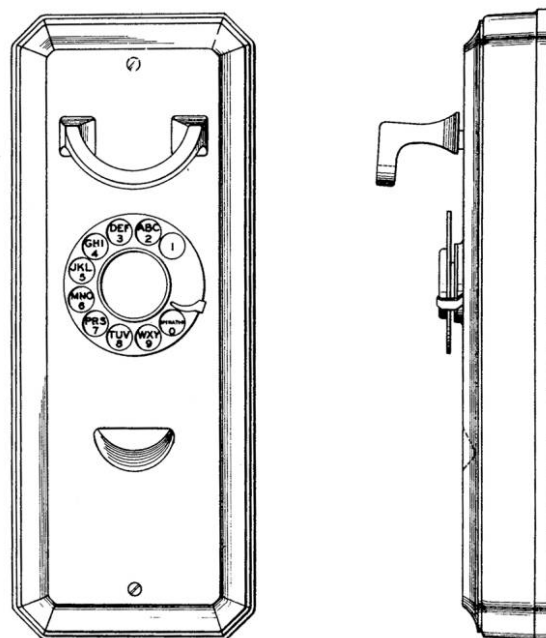

Fig. 10. Patent drawings of prototype wall phone, detail of figs. 1 and 3 from George R. Lum (assignor to Bell Telephone Laboratories), "Wall Mounting for a Hand Telephone," patent D85,107, filed 1931. (US Patent and Trademark Office.)

line, and Design Line phones discussed below). A few notes were found of early meetings that Dreyfuss attended at Bell Labs, so it is clear that he "had a hand in the design" as a consultant.

On the other hand, design patents for the new desk stand, the handset, and even the related No. 354 wall phone were all awarded solely to George R. Lum (1889–1989), a design engineer at Bell Labs (fig. 5).<sup>12</sup> Although patents are sometimes granted to company executives or owners when the actual work was done by their employees, this would have been contrary to Bell Labs policy on patent assignments.<sup>13</sup> Further, Lum had a record of numerous other patents on ornamental designs, and on his twenty-fifth anniversary with the Bell System, the company explicitly gave him credit for designing the handset and the combined set (the 302).<sup>14</sup> Also, Lum's training in the fine arts was clearly sufficient to enable such design work.

<sup>12</sup> "George R. Lum," *Colorado Springs (Colo.) Gazette-Telegraph*, January 3, 1982, 4A. See also the following by George R. Lum: "Desk Stand for a Hand Telephone," *United States Patent* (des. 95,765, filed March 27, 1935); "Hand Telephone," *United States Patent* (des. 95,915, filed April 25, 1935); and "Wall Mounting for a Hand Telephone," *United States Patent* (des. 152,276, filed December 9, 1947).

<sup>13</sup> Ralph Bown, "Inventing and Patenting at Bell Laboratories," *Bell Laboratories Record* 32 (January 1954): 8.

<sup>14</sup> "Twenty-Five-Year Service Anniversaries," *Bell Laboratories Record* 21 (January 1943): xxii.

Nevertheless, some features on the production 302 appear to be characteristic of Henry Dreyfuss's work. One feature is the prominent ridge on top of the new F-type handset (fig. 6), which is reminiscent of the streamlined Hudson J3a locomotive that Dreyfuss was designing during this period. Another is the cavity below the integrated cradle that forms a handhold, which is seen clearly in Lum's patent drawing (fig. 7). A handhold is found on all subsequent desk phones designed by Dreyfuss and his associates. As Dreyfuss was working as a consultant, it is almost certain that he provided some suggestions or recommendations—probably on these features and the improved symmetry (concave surfaces on all sides) of the production 302.

Another myth about the 302 telephone—that its design was inspired by a 1931 Ericsson phone—has also been perpetuated by Lupton, Flinchum, and Hiesinger and Marcus.<sup>15</sup> The Ericsson phone, shown in figure 8, has similarities to the 302, so inferring a connection is understandable. But the timing is wrong.

<sup>15</sup> Flinchum, *Henry Dreyfuss, Industrial Designer*, 97; Lupton, *Beautiful Users*, 22; Hiesinger and Marcus, *Landmarks of Twentieth-Century Design*, 121.



Fig. 11. Western Electric 500 desk telephone, 1949. (Gregg Museum of Art and Design.)

Design of the Swedish Ericsson phone originated in 1929 with Johan Bjerknes, who was the design manager for Ericsson's subsidiary in Norway, the Elektrisk Bureau.<sup>16</sup> Bjerknes's initial concepts were given to the well-known Norwegian artist, Jean Heiberg, in September 1930. By January 1931, Heiberg produced a model in plaster, and Ericsson began production of this phone in October 1931. Ericsson's 1931 model was announced in the *Ericsson Review* at the end of the year and eventually became known as the Ericsson DBH-1101 (DBH-1100 lacked a dial).<sup>17</sup> It is likely that Bell Labs got their first glimpse of the Ericsson design when the *Ericsson Review* announcing the 1931 model arrived (by boat) in New Jersey no earlier than late January or early February 1932.

<sup>16</sup> G. Grönwall, "The New Ericsson Telephone," *L. M. Ericsson Review* (English ed.) 10, no. 1 (1933): 4; Lasse Brunnström, *Telefonen en Designhistoria* (Stockholm: Bokförlaget Atlantis, 2006), 176–79.

<sup>17</sup> "The New Ericsson Subscriber's Automatic Telephone 1931 Model," *L. M. Ericsson Review* (English ed.) 9, nos. 10–12 (1931): 266.

Yet by October 20, 1932, George Lum had filed applications for patents for the 302's precursor (fig. 9), which had most of the external design features of the desk stand for the eventual production 302.<sup>18</sup> Prototypes of this design were made, and surviving specimens have been found with manufacturing date stamps of IV32 (fourth quarter of 1932).<sup>19</sup> Considering the time required for the layout of components and the fabrication of tooling, it is clear that Lum's external design for this prototype was made long before his patent filing date in October 1932.

It is also significant that Lum had used concave surfaces with an incised line such as appears on the production 302 on an even earlier design (fig. 10).<sup>20</sup>

<sup>18</sup> George R. Lum, "Telephone Substation Apparatus," *United States Patent* (2,008,287, filed October 20, 1932).

<sup>19</sup> Paul Fassbender, "Western Electric D-95647 Sold for \$3,150," *Singing Wires: The Journal of Telephone Collectors International* 25, no. 12 (December 15, 2011): 1.

<sup>20</sup> George R. Lum, "Wall Mounting for a Hand Telephone," *United States Patent* (des. 85,107, filed August 1, 1931).



Fig. 12. Robert H. Hose, 1967. (Hoover Historical Center at Walsh University, North Canton, Ohio.)

This design also resulted in prototype fabrication.<sup>21</sup> It thus seems certain that Lum had developed the basic features of the production 302 before he could have seen the Ericsson design. That means that the Ericsson phone could not have played a role in the design of the 302.

#### The Postwar No. 500 Standard Telephone

After World War II, Bell Labs made a number of technical improvements that merited a new design, and the pent-up wartime demand for telephone service was substantial.<sup>22</sup> Most of the electrical com-

<sup>21</sup> "Western Electric Prototypes," *Singing Wires: The Journal of Telephone Collectors International* 5 (May 15, 1991): 5.

<sup>22</sup> "The New Look in Telephone Instruments," *Bell Laboratories Record* 27 (May 1949): 165; "Bennett Talks About New Telephone," *Bell Laboratories Record* 27 (May 1949): 188.

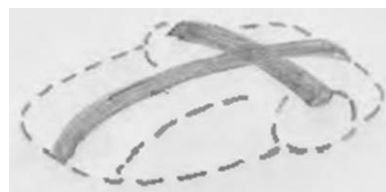

Fig. 13. Sketch, Alvin Tilley, concept for the 500 telephone, 1953. (Henry Dreyfuss Associates.)

ponents of the telephone's circuit were now small enough to be contained in a can, called a network, which was fastened to the base. The housing would be a plastic shell that could be removed from the phone without disturbing any working parts. It was felt that all aspects of the ornamental design should be freshly considered for the new model.<sup>23</sup> Consequently, Dreyfuss was called in to collaborate with the Bell Labs engineers on the new telephone at a very early stage in the project. At the same time, Bell Lab's own staff designer, Robert Hose, went to work on the form of the new telephone. Hose felt that the technical experience he had acquired at Bell had been of great value in his subsequent work as a designer.

Shortly after work on the new telephone commenced in 1946, the Bell System's directors decided that there was duplication between their in-house designer and Dreyfuss. Wallace reports that "accordingly Hose left his post in the Bell organization and joined Dreyfuss on the telephone project."<sup>24</sup> William Purcell, who was a partner and Dreyfuss's right-hand man in the Pasadena office, said that Dreyfuss in fact hired Hose away from Bell Labs to eliminate the possibility of competition.<sup>25</sup> There was therefore natural friction between Hose and Dreyfuss, and Dreyfuss instructed Purcell to "Get him!" Thus it was Purcell, who was Hose's brother-in-law, rather than Dreyfuss himself, who brought the new designer into the firm in 1946. The new 500 desk telephone is shown in figure 11.

Robert Haven Hose (1915–19), the new designer (fig. 12) for Henry Dreyfuss, would have worked at Bell Labs with Lum, who hadn't retired yet.<sup>26</sup> Hose

<sup>23</sup> Don Wallace, *Shaping America's Products* (New York: Reinhold, 1956), 36.

<sup>24</sup> *Ibid.*

<sup>25</sup> William F. H. Purcell, interview with Russell Flinchum, Tiverton, Rhode Island, March 16–17, 1991.

<sup>26</sup> "Robert H. Hose," [www.idsa.org](http://www.idsa.org) (Herndon, VA: Industrial Designers Society of America, 2016); "The Consumer's Best Friend," *Hoover Worldwide* (Spring 1967): 12.

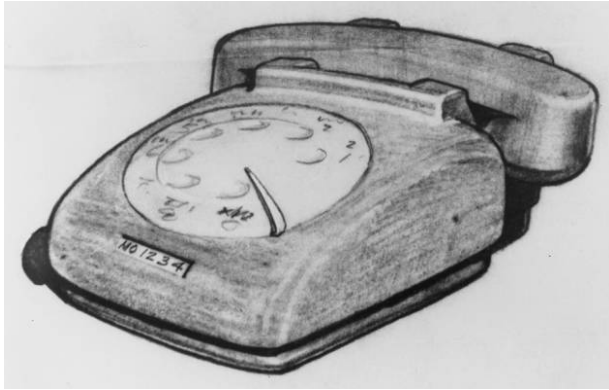

Fig. 14. Sketch, Robert H. Hose, proposed new phone, 1946. (Henry Dreyfuss Associates.)

completed a master's degree in architecture at MIT in 1940 and was an accomplished designer. He would serve in 1953 as president of the Society of Industrial Designers, one predecessor of today's Industrial Designers Society of America (IDSA), and as president of the IDSA from 1967 to 1968.

But Dreyfuss and Hose worked in separate offices, which may have circumvented personal tension relating to the Bell System designs. In 1946 Hose moved the short distance from Bell Labs in New Jersey to the Dreyfuss firm in New York City. Dreyfuss, on the other hand, had previously moved his residence to Pasadena and opened an office there, where he was close to some of his West Coast clients (e.g., Consolidated Vultee and later Lockheed Aircraft Company). Thus Hose and a local staff of about thirty employees were given the job of designing the new telephone in the New York office.

Notes compiled by Alvin Tilley, the principal design engineer at the Dreyfuss firm, offer insights into designing the 500 telephone. "The theme for the composition of receiver on stand in unison became a convex line lying transversely on top of a longer convex line as shown" (fig. 13).<sup>27</sup> Data from Bell Labs for the handset preceded information for the desk stand to such an extent that they were almost designed separately, with only this theme in the minds of some for tying the forms together. The earliest image of the new telephone design is shown in Hose's 1946 sketch in figure 14.

This new G-type handset is best understood as successor to the E and F types. When designing the original E-type handset for their first handset desk stand of 1927 (the same handset as in fig. 4), Bell

<sup>27</sup> Alvin Tilley, May 1953 notes, 2 (former accession no. 1973.15.5), Henry Dreyfuss Archive, 1954–68, Cooper Hewitt, Smithsonian Design Museum, New York.

Labs made thousands of head measurements on a diverse population of subjects to determine optimal distance and angle between ear to mouth: "The subjects selected for these measurements included both sexes and the various races in about the proportion indicated by the census figures."<sup>28</sup> The results from the early 1920s (fig. 15) were used to obtain critical or modal dimensions for the handset. In the large array of data on the right, distances are grouped in half-centimeter intervals and angles are grouped in two-degree intervals. There are a total of 3,888 measurements in this array, made with a special gauge that had a receiver cap which was held to the subject's ear. Only twenty-two measurements are equal to or exceed 16 cm from the center of the receiver cap to the center of the mouth; these long heads comprise just 0.6 percent of 3,888. Thus, if the handset were designed with a modal distance of 15½ cm, it would be long enough to encompass more than 99 percent of all heads measured.

The scientists who made these measurements used the metric system. But in the 1920s, Bell Labs engineers had to work in inches because American machine tools were calibrated in inches. The equivalent of 15½ cm is 6.102 inches, and the closest rounded fraction is 6⅞ inches. Figure 16 shows the modal dimensions of a production E-type handset as measured by the authors. The modal distance is indeed 6⅞ inches.

The 10-degree modal angle is defined as that between the plane of the receiver cap and a line joining the center of the receiver cap to the center of the mouth (see fig. 15). By moving the transmitter out of the plane of the receiver by just 10 degrees, the transmitter is closer to the mouth without extending too far inward for the narrowest heads (overextending for only about 3 percent of the measured heads).<sup>29</sup> For these narrowest heads, the transmitter can be brought closer to the mouth by a slight shift of the receiver on the ear. Face clearance is ensured by extending the transmitter and receiver from the handle by an amount that is greater than the distance from the handle to the cheek (about 2 cm for the widest heads), an extension that is exceeded by the large size of the early transmitter and receiver units.

Finally, the other angle that had to be set was the tilt of the transmitter. By setting this angle at 40 degrees as measured, the transmitter would be at the

<sup>28</sup> W. C. Jones and A. H. Inglis, "The Development of a Handset for Telephone Stations," *Bell System Technical Journal* 11 (April 1932): 262.

<sup>29</sup> *Ibid.*, 263.

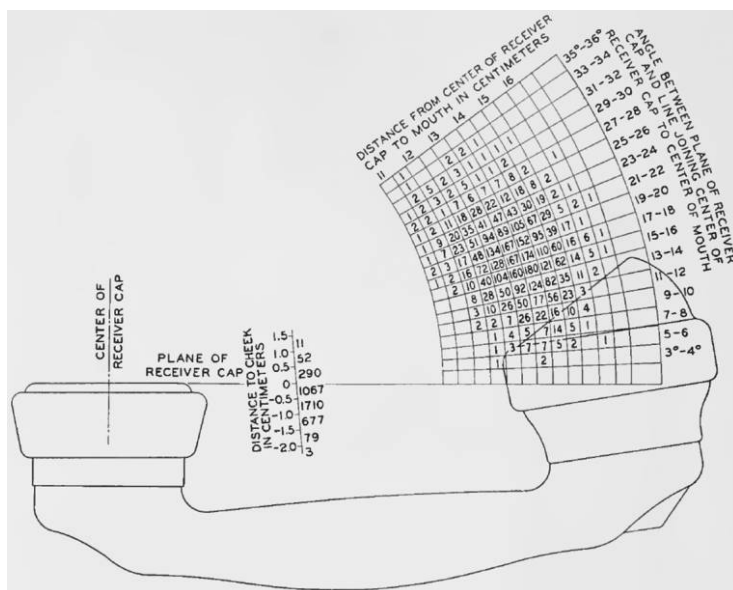

Fig. 15. Distribution of Bell Labs head measurements, 1932. From W. C. Jones and A. H. Inglis, "The Development of a Handset for Telephone Stations," *Bell System Technical Journal* 11 (April 1932): 262.

side of the mouth, yet angled toward the mouth, for all head sizes. It would not be possible to orient the transmitter to face directly toward the mouth for all head sizes with a single fixed angle.

Our measurements reveal the expected similarities between the E- and F-type handsets, which were designed for interchangeable use on the 302 and earlier desk stands.<sup>30</sup> Figure 17 shows that our measurements of modal distance and angle—and even the tilt of the transmitter—for the F-type handset of the 302 telephone are exactly the same as for the earlier E-type handset. The extensions of the transmitter and receiver from the handle on the F type are a little shorter because the transmitter unit and the receiver unit are smaller than on the E type, yet clearance is still greater than the distance-to-cheek measurements.

Figure 18 shows our measurements for the G-type handset, which the Dreyfuss firm designed for the postwar 500-series telephone. The modal angle is the same, 10 degrees, but the modal distance is exactly one-half inch shorter than the previous handsets because this nominal reduction was desired to make the handset lighter and easier to handle.<sup>31</sup> Bell Labs measurements (see fig. 15) show that

<sup>30</sup> W. C. Jones, "Instruments for the New Telephone Sets," *Bell System Technical Journal* 17 (July 1938): 341.

<sup>31</sup> L. J. Cobb, "Handset for the 500-Type Set," *Bell Laboratories Record* 30, no. 8 (August 1952): 317.

5½ inches (14.3 cm) is sufficiently long to extend from mouth to ear for more than 90 percent of the faces measured. Dreyfuss was free to reduce the tilt of the transmitter from 40 degrees to 32½ degrees (7½ degrees is just a nominal three-quarters of 10 degrees) for more face clearance with no significant loss of performance because of the increased sensitivity of the new T1 transmitter unit.

A human engineering drawing depicting the G-type handset, created by Dreyfuss's Alvin Tilley in 1965 for publicity purposes (fig. 19), helps the viewer to visualize the relationships between handset size and orientation and head shape and clearances. A similar Tilley drawing (fig. 20) graphically represents the data distribution. This graphic corresponds exactly with the old data (see fig. 15)

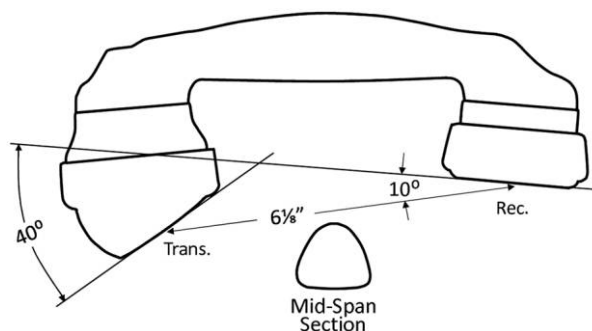

Fig. 16. Outlines and modal dimensions, E-type handset. (Ralph Meyer.)

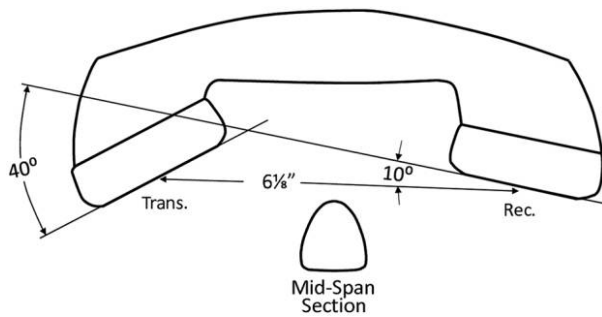

Fig. 17. Outlines and modal dimensions, F-type handset. (Ralph Meyer.)

grouped into intervals of 20 percent of the total number, with the darkest color for the most frequent. The drawings for the postwar handset are thus seen to be based on the old 1920s measurements. Despite the updated drawings, no new anthropometric measurements were made. The dimensions of the new G-type handset were copied from the earlier E- and F-type handsets (although shortened slightly), and those dimensions were derived entirely from the Bell Labs measurements of the 1920s. But the shape of the handle cross-section was new, and this shape was significant.

Tilley describes designing the handle: "The convex curve in the handle of the handset was thoroughly justified. At one time, we tried a straight line, 'the shortest distance between two points being a straight line,' but we soon found the ends became very large and wasteful of material. This fact had been recognized in the existing and older designs."<sup>32</sup> Tilley goes on to say: "Assembly drawings were made to study the required volume, rough sketches were made for various designs, model drawings were prepared, and we immediately went into wood mock-ups of about eight designs" (fig. 21).

Tilley also reports that the models were sitting on a desk one day when Dreyfuss walked into the New York office from out of town. He picked up one handset, held it to his ear, and said it gave him "griptomphobia." Then he walked out. The staff immediately went to work and leveled out this one design, making the rectangular cross-section area less fat and rounding the lower corners for greater comfort, increasing finger space but maintaining the basic rectangular overall plan of the design. Thus, a less extreme form was chosen that retained the original conception of the large, flat surface that the handset presented when placed in its cradle (see fig. 14). The design patent for this G-type hand-

<sup>32</sup> Alvin Tilley, May 1953 notes, 2.

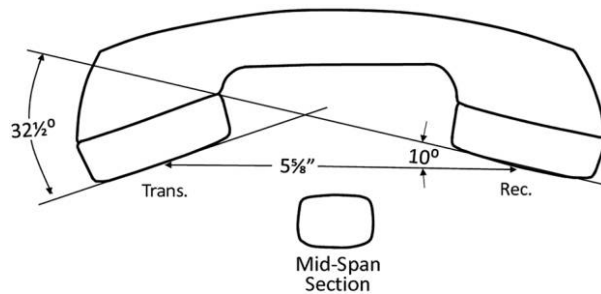

Fig. 18. Outlines and modal dimensions, G-type handset. (Ralph Meyer.)

set was filed on June 24, 1947, by Henry Dreyfuss, and his was the sole name on the patent.<sup>33</sup>

The shape of the handle was in fact a brilliant innovation. Handsets with triangular cross-sections were very awkward to hold and could not be "shouldered" hands-free at all (see figs. 16–18). Further, the earlier handsets were hard to service because they would not lie flat on a work surface. The new flat-back shape has persisted in all modern telephone handsets, and this handle shape is truly an undervalued accomplishment.

In the New York office, Robert Hose continued work on the 500 desk stand. His sketch (see fig. 14) suggests the overall smooth contours being sought in the 500. Tilley notes that the shape was called the "shoeform" by the staff, and Tilley's colorful words describe the design concept: "All external surfaces were convex with optical cambers to reduce its apparent size. The predecessor [the 302, see fig. 7] was essentially an upper section of four concave walls superimposed over a rectangular base. Hence the original conception was the logical outcome of three of our axioms: 1) simplify form, 2) if it is circular make it square, and if it is square make it round, and 3) a design that is neither concave nor convex and without sex is the darndest thing!"<sup>34</sup>

Tilley goes on to say that actual design of the desk set commenced when Bell Labs provided measurements of the dial mechanism, ringer, electrical network, condenser, sound-level equalizer, and switch spring assembly. These units were put together in such a way as to reduce the overall height of the phone, lower the dial, and flatten its angle to improve the visibility and manual comfort of the user. Sketches were made, followed by accurate layout drawings; then full-size models were studied in clay (plasticine).

<sup>33</sup> Henry Dreyfuss, "Hand Telephone," *United States Patent* (des. 151,614, filed June 24, 1947).

<sup>34</sup> Alvin Tilley, May 1953 notes, 1.

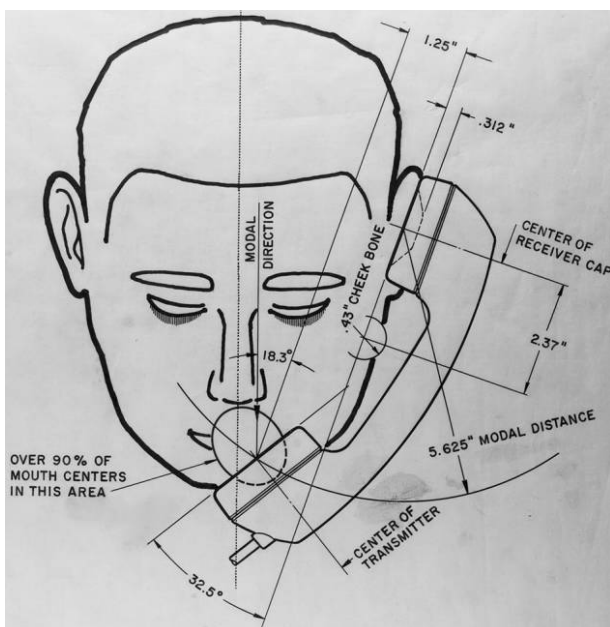

Fig. 19. Drawing, Alvin Tilley, modal dimensions, G-type handset in use, 1965. (Henry Dreyfuss Associates.)

When several designs appeared rational, Tilley says they were cast in plaster and sculpted. Some were painted and equipped with mock components, such as handset, dials, and cords, to simulate the real thing.<sup>35</sup> Changes came sporadically, according to Tilley: “it was found one day that three cents could be saved by using a certain wire on the windings with the result that we could lower the housing 1/8 of an inch. But some other details sometimes raised the housing; for example, to improve the bell tone, the diameter of the bells was increased.” The result was that the design literally had its ups and downs.<sup>36</sup>

After establishing the overall shape, Dreyfuss designers and Bell Labs engineers struggled over the shape of the cradle or switch hook. According to Tilley, most Dreyfuss designers preferred the flush cradle, particularly without the handset in place. Models were made with pockets cut out on both sides of the housing to receive the ends of the handset. Two problems resulted: first, the compact “shoe” form was lost, and, second, the demands on the telephone user were too exacting since the handset had to be lowered into these wells almost vertically. “As a compromise, we added two hook prongs in the rear and opened the wells in the back.”<sup>37</sup>

<sup>35</sup> Ibid., 3.

<sup>36</sup> Ibid.

<sup>37</sup> Ibid., 4.

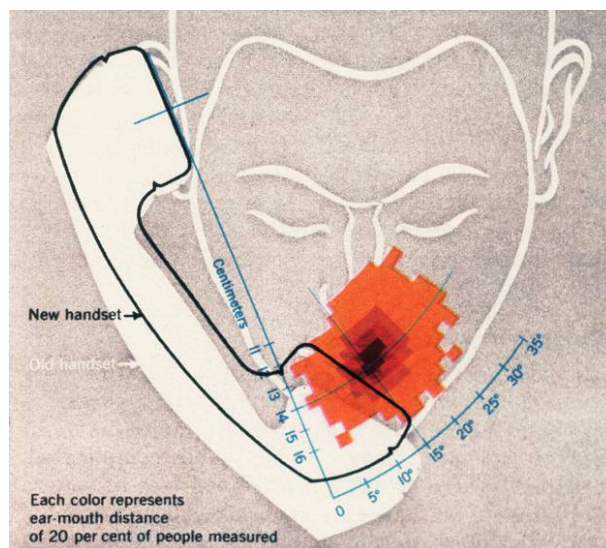

Fig. 20. Drawing, Alvin Tilley, comparing G- (new) and F-type (old) handsets with head measurement distribution data, ca. 1953. (Henry Dreyfuss Associates.)

Throughout many months of meetings and transportation of models between the Dreyfuss office and Bell Labs, most design staff refused to accept the four-prong switch hooks that the engineers preferred, although Tilley reported that some designers actually preferred the four-prong switch-hook idea in that it provided a visual focal point for the proper location of the handset. “During one of the lull periods, a few of the staff casually tried modeling a four prong job and we hit upon a happy coincidence of harmony between the front line of the prongs and the lines of the body cut-out. Heretofore, the front prongs always appeared detached. We had just finished smoothing the clay when HD walked in on one of his quick inspections after a siege of out of town travels. He looked at the model, was interested, and asked our model maker what he thought of the form. An affirmative answer was received, and, with a nod from HD, the battle of the prongs was over.”<sup>38</sup> The design patent for the 500 desk stand was issued jointly to Dreyfuss and Hose, and a drawing from the patent is shown in figure 22.<sup>39</sup>

Two convenience features of this desk stand are notable. One was the handhold cavity beneath the cradle, which was carried over directly from the 302 telephone (fig. 23, and see fig. 7). The other feature

<sup>38</sup> Ibid.

<sup>39</sup> Henry Dreyfuss and Robert H. Hose, “Desk Stand for a Hand Telephone,” *United States Patent* (des. 153,927, filed February 11, 1948).



Fig. 21. Wooden handset prototypes showing F-type handset at upper left and Hose's original concept at right, third from top, ca. 1947. (Henry Dreyfuss Associates.)

was the relocation of the dial numbers and letters from beneath the finger holes to outside the fingerwheel (see fig. 11). This shift made the numbers visible from a wide angle and less subject to damage from dialing. The relocation of dial numbers was not new with the 500 design. This practice dates from the late 1920s when Gray, a pay phone manufacturer for the Bell System, used this feature to make numbers more visible in poorly lit pay phone booths. In these early pay phones, the background was white underneath the black fingerwheel so that the user could easily tell when dial rotation ceased. The presence of the outboard numbers in Hose's early sketch (see fig. 14) indicates that the concept came from Bell Labs, rather than from Henry Dreyfuss.

Testing of this design prior to field trials showed that dialing time for the 500 was slower than for the 302.<sup>40</sup> Slower dialing was undesirable because it increased circuit-holding time, which tied up trunk lines. John Karlin, an experimental psychologist hired by Bell Labs, determined that people had difficulty telling when the fingerwheel had stopped moving because it was black against a black background.<sup>41</sup> He suggested placing white dots beneath the holes in the fingerwheel, and these aiming dots

<sup>40</sup> R. Black and H. K. Cunningham, "Testing Telephone Usefulness," *Bell Laboratories Record* 32, no. 1 (January 1954): 25–26.

<sup>41</sup> B. L. Hanson, "A Brief History of Applied Behavioral Science at Bell Laboratories," *Bell System Technical Journal* 62, no. 6 (July–August 1983): 1576.

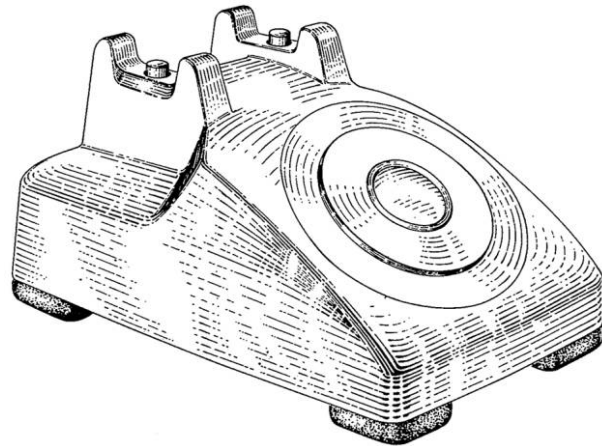

Fig. 22. Patent drawing of 500 desk set, detail of fig. 1 from Henry Dreyfuss and Robert H. Hose (assignors to Bell Telephone Laboratories), "Design for a Desk Stand for a Hand Telephone," patent D153,927, filed 1948. (US Patent and Trademark Office.)

solved the problem (fig. 24). Available reports do not specify whether dialing with dots was actually faster than with the old dials, but the outboard numbers were not used on any future designs (namely, the Princess and the Trimline).

Two years after the 500 telephone was introduced, a cross-licensing patent agreement was reached that made this design an industry standard that would be manufactured and copied by others.<sup>42</sup> Kellogg and Stromberg-Carlson manufactured phones with interchangeable parts and the same model numbering as Western Electric's phones; Automatic Electric copied many of the features of these phones, including the dial with outboard numbers. In 1959, the No. 500 telephone was recognized as one of the ten "best designed products of modern times" in a poll of leading industrial designers.<sup>43</sup>

#### 500-Series Telephone Variations

By 1956, a wall phone companion to the 500 desk phone had been designed. This No. 554 wall set (fig. 25) had all components mounted on a steel base and was enclosed in a thermoplastic shell like the 500 desk set. The same dial with outboard numbers was used. Like all the phones in this series it used the G-type handset. Although no notes or de-

<sup>42</sup> Meyer, *Old-Time Telephones! Design, History, and Restoration*, 89–91.

<sup>43</sup> "Designers Honor 500-Type Set," *Bell Laboratories Record* 37, no. 4 (April 1959): 151.



Fig. 23. Western Electric 500 showing handhold, 1949. (Gregg Museum of Art and Design.)

sign patent for the 554 have been found, we assume that the 500 design team also worked on the 554 wall set.

In early 1956, designers in Dreyfuss's office gave a co-op student from Pratt Institute in Brooklyn working one day a week the task—his first assignment—of providing a temporary perch for an off-hook handset on the 554.<sup>44</sup> The student gave rough sketches to John Amore, Dreyfuss's model maker, who added clay to the 554's upper housing to provide the subtle creases. This model was used to make a mold, and from the mold Amore cast an all-plaster replica that was sanded and painted. Testing showed that it worked. The creases, with a short "waterfall" coming down from them, were added to production 554s. Thus began the illustrious career of Donald Genaro (fig. 26). He became a partner in the Dreyfuss firm in 1966 and senior partner of Henry Dreyfuss Associates in 1982, long after Dreyfuss had retired.

At the heart of the game-changing development of touchtone circuitry was the transistor, which was invented at Bell Labs and secured a Nobel Prize for its inventors.<sup>45</sup> The touchtone version of the 500 desk phone with its keypad dial was introduced in 1963. Genaro was given design responsibility for the new desk stand.<sup>46</sup> His design modification was patented (fig. 27).<sup>47</sup>

Except for the touchtone unit, which contained its transistorized tone-generating circuitry, the cir-



Fig. 24. Western Electric dial for 500 showing white dots, 1949. (Ralph Meyer.)

cuit and components mounted on the base remained almost unchanged. Therefore, Genaro left the back end of the 500 style alone and brought the front surface up to a flat 4-inch-square surface with ever so slightly bowed-out edges. Like the rotary dial, the touchtone keypad was mounted on a bracket on the base, yet the entire flat surface was also removable. The 1963 touchtone phone, the No. 1500, had ten buttons; when the star and pound key were added in 1968, the model number was changed to 2500. The large flat surface around the dial made it easy to position the number card, to add a switch for two-line phones, and to add an indicator light for applications in private exchanges. With some stretching of this flat surface, a row of keys (switches) was also placed along the bottom to make multiline business phones.

The final variation of the 500 design was a small wall phone. This phone was actually designed earlier for use with a rotary dial (fig. 28), and a design patent was applied for in 1958.<sup>48</sup> By this time more solid-state components were used within the network's can, the can had hence been reduced in size, and a smaller ringer was developed. The small wall set was designed to take advantage of this decreased size, but rotary dials were outmoded. Although Western Electric made a prototype of this phone, they never introduced a production rotary version of the small wall set (other manufacturers did, however).<sup>49</sup>

The Dreyfuss firm designed a touchtone version of the small wall set, however, and Donald Ge-

<sup>44</sup> Donald Genaro, email to authors, June 9, 2016, 1:02 pm.

<sup>45</sup> "Nobel Prize Awarded to Transistor Inventors," *Bell Laboratories Record* 34, no. 11 (November 1956): 401.

<sup>46</sup> Donald Genaro, email to authors, May 21, 2016, 3:18 pm.

<sup>47</sup> Henry Dreyfuss, "Pushbutton Telephone Desk Stand," *United States Patent* (des. 197,067, filed October 17, 1962).

<sup>48</sup> Henry Dreyfuss and Robert H. Hose, "Telephone Mounting," *United States Patent* (des. 185,742, filed December 10, 1958).

<sup>49</sup> Paul Fassbender, "'Slimphone'—The Wall Princess?," *Singing Wires: The Journal of Telephone Collectors International* 31, no. 2 (February 2017): 1.



Fig. 25. Western Electric 554 wall telephone, 1956. (Gregg Museum of Art and Design.)

naro was again given the job of modifying a design to accommodate a touchtone keypad.<sup>50</sup> In the initial design (see fig. 28), the handset cradle was a large casting that also made up the top and sides of the housing. Such a design was expensive to manufacture and involved a lot of chrome-plated metal. Genaro modified the handset cradle without altering the overall shape of the housing. In like manner to the touchtone desk stand, the small touchtone wall phone was introduced in 1963 with ten buttons as the Western Electric No. 1554 telephone, and the model number was changed to 2554 when the twelve-button keypad came into use (fig. 29). This wall phone was too small to provide a place to hang an off-hook handset from the top as on the large 554 wall phone. However, the handset cradle was extended to hold the handset horizontally when it

<sup>50</sup> Donald Genaro, email to authors, June 20, 2016, 11:08 am.



Fig. 26. Donald M. Genaro, 1966. (Donald M. Genaro.)

was off-hook without disconnecting the circuit, a feature of all the Dreyfuss firm's wall phones.

### The Princess Telephone

By the mid 1950s, Bell Labs had a new marketing division and decided to pursue a full-scale, full-time program of selling its products and services—and of devising new ones to sell.<sup>51</sup> One of the first products of this program was a new bedroom model, the Princess, in 1959 (fig. 30). All earlier Bell telephones had been designed to incorporate technical advances that improved performance and lowered costs, but no new technical features were incorporated in the Princess. Its design was purely for marketing purposes.

Although the Princess phone was a radical departure from traditional telephone designs focused on function, its design concept was not entirely new. The failed 1929 design competition produced one interesting design. In that competition, Gustav Jensen, a well-known independent designer, proposed an oblong art deco design with the handset strad-

<sup>51</sup> William S. Brown, "A Decade of New Products," *Bell Telephone Magazine* 45, no. 1 (Spring 1966): 13.

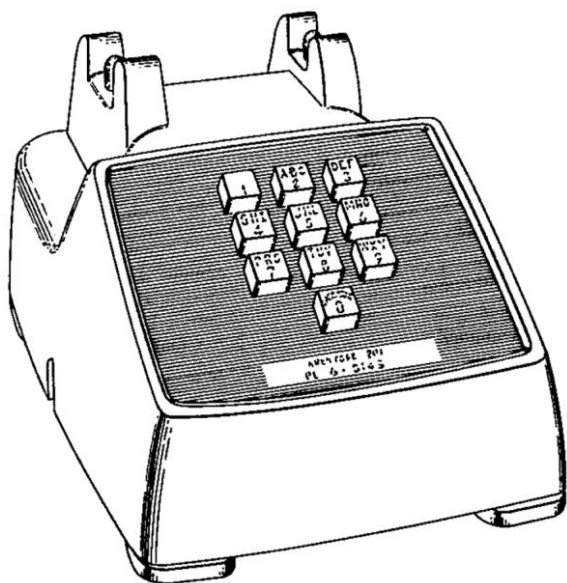

Fig. 27. Patent drawing of Donald M. Genaro's touchtone modification, detail of fig. 1 from Henry Dreyfuss (assignor to Bell Telephone Laboratories), "Pushbutton Telephone Deskstand," patent D197,067, filed 1962. (US Patent and Trademark Office.)

dling the dial (fig. 31).<sup>52</sup> Three other patents with this configuration were cited in the eventual patent for the Princess design, but none was as similar in appearance to the Princess as was Jensen's design.<sup>53</sup>

The Princess telephone used the same G-type handset as the 500-series phones, but the desk set had a distinctly different footprint than the 500 desk set and, therefore, required reconfiguring the interior components. This work was done by Bell Labs in New Jersey. Exterior design of the Princess desk set was thus a job for Dreyfuss's nearby New York office.

By the mid-1950s, James Burlin was managing the day-to-day activities of the Bell Labs account and would have handled the many meetings and interactions with the Bell System engineers. A patent for the ornamental design of this desk set was issued to Burlin and Hose jointly (fig. 32). We believe, however, that Hose was the principal designer of the Princess as Burlin was primarily a manager. The absence of Dreyfuss's name from this patent is surprising due to his typical involvement in the firm's telephone designs, and his name seems to appear on all other patents generated by his office.

<sup>52</sup> Linton Wilson, "Gustav Jensen," *Pencil Points* (March 1937): 135.

<sup>53</sup> James N. Burlin and Robert H. Hose, "Telephone Stand," *United States Patent* (des. 182,498, filed December 17, 1956).

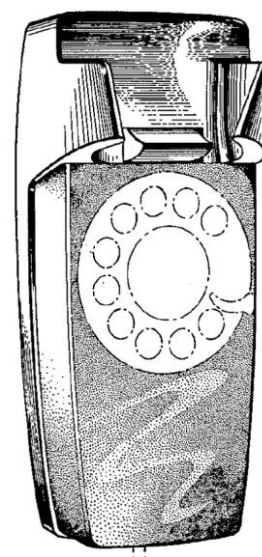

Fig. 28. Patent drawing of small wall phone, detail of fig. 3 from Henry Dreyfuss and Robert H. Hose (assignors to Bell Telephone Laboratories), "Telephone Mounting," patent D185,742, filed 1958. (US Patent and Trademark Office.)

By the autumn of 1957, market trials were under way in Illinois and Pennsylvania with prototypes that looked exactly like the patent drawing.<sup>54</sup> On these sets, as on the patent drawing, there was an overhanging lip just below the dial (fig. 33). This lip, and a similar one in the rear, were intentional features of the design to permit the desk set to be picked up with one hand straddling the handset—the signature feature of the Dreyfuss firm's desk telephones. Although the overall shape of the housing was pyramidal (that is, broader at the bottom), which would have allowed molding in a single piece, the overhanging lip prevented this. Consequently, the housings for field trial sets in 1957 were molded in two pieces that were glued together around this lip, as can be seen in figure 34.<sup>55</sup>

Genaro, who often worked out practical solutions for Dreyfuss design challenges, was given the job of simplifying the molding process. Genaro recognized that the only way to gain that lip in a single piece was to use a slide in the die to create a revised

<sup>54</sup> "Headquarters Summary," *Bell Telephone Magazine* 36, no. 3 (Autumn 1957): 56.

<sup>55</sup> Untitled article, *Singing Wires: The Journal of Telephone Collectors International* 8, no. 3 (March 15, 1994): 8.



Fig. 29. Western Electric 2554 wall set, 1968. (Gregg Museum of Art and Design.)

draft and a resultant undercut.<sup>56</sup> The only minor appearance drawback to this approach was the witness lines that were created by the slide (fig. 35). To accomplish the die modification, Genaro worked with a small Bell Labs group that worked in the Western Electric factory complex in Indianapolis.

Another convenience feature of the Princess was an internal light that doubled as a night light and a dial light. When the handset was lifted, the soft night light would brighten to illuminate the dial for nighttime dialing. A sliding switch was provided so the night light could be turned off, but the dial would still light up when the handset was lifted. That switch is visible in the patent drawing and the field-trial set (see figs. 32, 34), but for production the switch was moved to the rear edge of the metal base, thus further simplifying the housing. The internal light was incandescent and required power from a baseboard transformer via an extra pair of wires in the line cord.

<sup>56</sup> Donald Genaro, letter to authors, March 17, 2016.

For several years there was no ringer in the Princess desk set, and a half-pound lead weight was put in the base to keep the phone from moving while being dialed. Eventually the small M-type ringer was installed in the set. As with the 500-series telephones, a touchtone version of the Princess desk set was produced (see fig. 35). Genaro again made the design modifications to accommodate the touchtone dial.<sup>57</sup> By mid-1965, more than 4 million Princess telephones were in service.<sup>58</sup>

After the industry move toward standardization following the introduction of the 500 telephone, the Princess phone was copied by other manufacturers. But the name Princess was registered as a trademark by the Bell System, so the copies were given other names. Kellogg's Cinderella phone had parts that were interchangeable with the Princess, Stromberg-Carlson's Petite phone looked just like the Princess, and Automatic Electric's Starlite phone was similar in appearance.

### The Trimline Telephone

The beautiful and familiar Trimline telephone (fig. 36) had a long and tortuous period of development.<sup>59</sup> Although the Bell System's developmental activities have been well documented in in-house periodicals, Dreyfuss firm activities have not and are detailed here for the first time. The concept began at Bell Labs with the lineman's test set of 1939, which had a rotary dial and all the telephone circuitry enclosed in a bulky handset. Starting in the early 1950s, five different dial-in-handset designs were developed sufficiently to be field tested: Demitasse, Shmoo, Contour, Trimline-I, and Trimline-II. Demitasse was awkward to hold, but confirmed interest in the concept. The others are discussed below with emphasis on the final production version of the dial-in-handset phone, simply called the Trimline—which was designed by Donald Genaro at the Dreyfuss firm.

The dial-in-handset (DIH) telephone (fig. 37) was nicknamed Shmoo because its shape resembled the popular cartoon character created by Al Capp. The Shmoo appeared in the "Li'l Abner" comic strip in 1948 (fig. 38). This telephone de-

<sup>57</sup> Donald Genaro, email to authors, June 29, 2016, 1:32 pm.

<sup>58</sup> Brown, "A Decade of New Products," 14.

<sup>59</sup> C. L. Krumreich and L. W. Mosing, "The Evolution of a Telephone," *Bell Laboratories Record* 44, no. 1 (January 1966): 9–14; Charles J. Sentenne, "The Trimline Telephone," *Bell Telephone Magazine* 44, no. 3 (Autumn 1965): 9–11.



Fig. 30. Princess telephone, 1959. (Gregg Museum of Art and Design.)

sign was Henry Dreyfuss's personal creation, and the design was patented in 1959.<sup>60</sup> The patent was shared with Hose and Burlin presumably because they managed Dreyfuss's New York office and the many interactions with nearby Bell Labs that were needed to engineer the internal components for the phone. The Shmoo telephone used the same No. 8 dial as the Princess. The Princess and earlier phones that used the G-type handset required two pairs of wires in the handset cord. With a dial and a light in the handset, two extra pairs of wires were needed in the handset cord, bringing the total to

<sup>60</sup> Donald Genaro, letter to authors, March 17, 2016; Henry Dreyfuss, Robert H. Hose, and James N. Burlin, "Telephone Set," *United States Patent* (des. 184,307, filed June 24, 1958).



Fig. 31. Gustav Jensen, Bell Labs design competition entry, 1929. From *Pencil Points*, March 1937, 135. (Photo, Ruth Bernhard.)

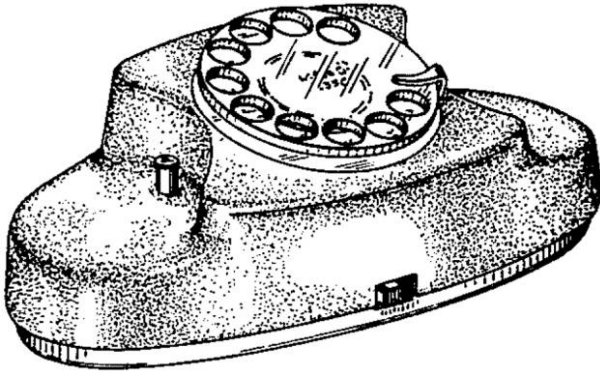

Fig. 32. Patent drawing of Princess telephone, detail of fig. 2 from James N. Burlin and Robert H. Hose (assignors to Bell Telephone Laboratories), "Telephone Stand," patent D182,498, filed 1956. (US Patent and Trademark Office.)

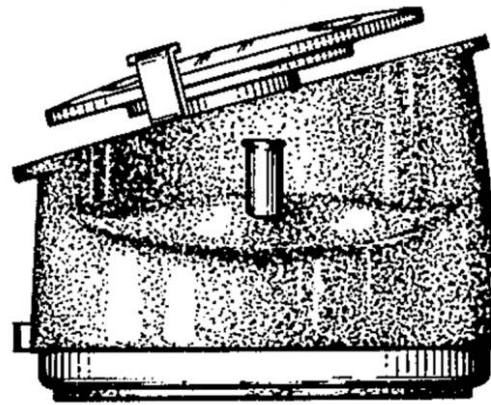

Fig. 33. Patent drawing of Princess telephone, detail of fig. 3 from James N. Burlin and Robert H. Hose (assignors to Bell Telephone Laboratories), "Telephone Stand," patent D182,498, filed 1956. (US Patent and Trademark Office.)

eight and making the cord rather stiff. The standard network circuit (with a modified can shape) was housed in the base of the Shmoo's desk set. The dial light required power from a baseboard transformer via an extra pair of wires in the line cord, just like the Princess telephone. Unfortunately, this phone's whimsical shape did not resonate well with test subjects.<sup>61</sup> Field trials with the Shmoo phone were first performed in New Jersey in 1959. Although the dial-in-handset format was twice as popular as the 500 set, many subjects complained that the handset was too bulky to hold comfortably.<sup>62</sup>

A modification of the Shmoo was made by Dreyfuss using a new small dial to make the handset narrower around the bottom. The small No. 10 space-saver dial was developed in 1959 by Charles F. Mattke at Bell Labs.<sup>63</sup> The Contour's smaller dial eliminated the gap between the 0 and 1 evident on the Shmoo (see fig. 37). The modified phone (fig. 39) is very similar to the Shmoo except for the smaller dial but was given a different name, Contour, thus avoiding association with the cartoon character.

The small dial was also used by Lionel W. Mosing to fashion a telephone of a more angular form, which Bell Labs called the Trimline (later Trimline-I).<sup>64</sup> Henry Dreyfuss was unaware that a group within Bell Labs had created the Trimline-I.

A drawing from Mosing's patent (fig. 40) incorrectly represents the small dial with a space between 1 and 0.<sup>65</sup> Like the Shmoo and Contour, Trimline-I had a dial light and still housed most of the circuitry in the desk base, thus requiring a rather stiff handset cord with eight wires.

In 1960 additional field trials were held in New Jersey and Pennsylvania with the Contour, the Trimline-I, and the original Shmoo.<sup>66</sup> In those trials, about half preferred Trimline-I, one-third preferred Contour, and one in eight preferred the Shmoo. Grouping the very similar Shmoo and Contour results, the field trials showed only a small preference for the Trimline-I (50 percent vs. 45 percent), but clearly the Shmoo was the least preferred of the three designs.

Genaro reports that Dreyfuss was deeply troubled by the extremely poor response to his Shmoo concept and Bell Lab's clandestine development of their own Trimline-I dial-in-handset phone.<sup>67</sup> Eventually Bell Labs assured Dreyfuss that his firm would be responsible for the dial-in-handset phone, and Dreyfuss gave the lead to Genaro in the New York office. Genaro asked Shortess to get everything on file from previous dial-in-handset studies and put them in the conference room (fig. 41). Genaro thought that the Trimline-I de-

<sup>61</sup> Donald Genaro, email to authors, August 5, 2016, 12:24 am.

<sup>62</sup> Krumreich and Mosing, "The Evolution of a Telephone," 13.

<sup>63</sup> B. L. Hanson, "A Brief History of Applied Behavioral Science at Bell Laboratories," 1578.

<sup>64</sup> Krumreich and Mosing, "The Evolution of a Telephone," 13.

<sup>65</sup> Lionel W. Mosing, "Combined Telephone Handset and Stand," *United States Patent* (des. 189,877, filed May 11, 1960). Mosing was a member of the Human Factors Group in the Bell Labs' Stations Study Department, part of John Karlin's department.

<sup>66</sup> Krumreich and Mosing, "The Evolution of a Telephone," 13.

<sup>67</sup> Donald Genaro, email to authors, July 27, 2016, 3:10 pm.



Fig. 34. Field-trial Princess showing two-piece construction, 1957. (Paul Fassbender.)

sign was unrefined and concluded that nothing was salvageable from the previous dial-in-handset designs, so they “started with a clean slate.” Dreyfuss and Genaro met with the Bell Labs team at the latter’s Holmdel, New Jersey, facility to begin coordination. According to Genaro, Dreyfuss’s input in the Trimline design process was limited to occasionally questioning or commenting on drawings and photos sent to the California office.

Genaro sketched some general approaches (e.g., fig. 42) and commenced three-dimensional studies as soon as possible. He did not want wood studies that took too long and couldn’t be readily modified, so Dreyfuss staff members used plaster. Amore prepared silicone molds from which they could cast numerous plaster examples. Thanks to his experience in plaster and clay modeling in the industrial design shop at Pratt Institute, Genaro “could scratch away with [his] own tools” to modify details.<sup>68</sup>

As was often the case, design patents were obtained soon after designs had been finalized, so a patent covering both the Trimline-II and the production Trimline (below) was applied for in 1964, just before the rotary-dial Trimline was introduced in 1965.<sup>69</sup> These patents were issued to Henry Dreyfuss and Bell Labs employees Lionel Mosing and Robert Prescott. The authors believe that this design patent inappropriately omitted the name of the

<sup>68</sup> Ibid.

<sup>69</sup> Henry Dreyfuss, Lionel W. Mosing, and Robert E. Prescott, “Combined Telephone Handset and Stand,” *United States Patent* (des. 202,787, filed September 21, 1964); Henry Dreyfuss, Lionel W. Mosing, and Robert E. Prescott, “Telephone Handset,” *United States Patent* (des. 202,788, filed September 21, 1964).



Fig. 35. Touchtone Princess desk set, ca. 1968. (Gregg Museum of Art and Design.)

artist who actually designed both objects. Genaro points out that every line, contour, and profile down to the smallest appearance detail was his doing.<sup>70</sup> Thus Genaro should be recognized as the creator of the only Dreyfuss-related design in the collection of the Museum of Modern Art, which does credit Genaro for this beautiful sculpture (see fig. 36). In field trials in 1963, customers in Michigan and Wisconsin preferred the Trimline-II set over the 500 set design by about nine to one.<sup>71</sup> The Trimline-II set was redesigned slightly, becoming the production Trimline telephone.

When the design began to jell, the Holmdel work was transferred to Indianapolis, where manufacturing by Western Electric would take place. On frequent trips to Indianapolis, Genaro would work with a small contingent of Bell Labs engineers who had permanent offices in the Western Electric complex. He reports that these Bell Labs people were incredible engineers who interfaced with Western Electric personnel and advanced the Trimline another step closer toward production. “Getting the forms I was after was no easy task for them—requiring flexible printed circuits, reverse drafts, snap fits, miniaturization, etc.”<sup>72</sup>

Genaro recalled the days in 1963 as being a series of running changes in components which had some effects here and there on the design, but nothing earth shaking.<sup>73</sup> One item that he worked to eliminate was the raised area over the transmitter. He “didn’t like the busy heel-of-a-shoe appearance

<sup>70</sup> Donald Genaro, email to authors, July 27, 2016, 3:10 pm.

<sup>71</sup> Krumreich and Mosing, “The Evolution of a Telephone,”

14.

<sup>72</sup> Donald Genaro, email to authors, July 27, 2016, 3:10 pm.

<sup>73</sup> Donald Genaro, email to authors, August 8, 2016, 7:45 pm.



Fig. 36. Trimline desk telephone, 1965. (Gregg Museum of Art and Design.)

and wanted to mirror the smooth, unbroken plane that the base had at that end” (fig. 43). Another improvement was the recall switch taking on a center position thanks to elimination of the hidden fastener by virtue of a snap fit.

Genaro continued making small adjustments, especially involving the details of the base’s contours around the “pockets” that cradled the handset. He wanted the user to be able to replace the handset with ease and not have to carefully place it in its nest. The 500 set excelled in that respect: “you could almost throw the handset in the general area of its cradle and it would home in. Receiver off hook (ROH) was to be avoided; the set should appear hung up if it indeed was, and if it wasn’t the set should look in disarray.”<sup>74</sup> Contouring of the base’s switch hook was also restudied to help nesting.

According to Genaro these adjustments took time because “plaster on plaster wouldn’t tell us much about the handset’s homing-in qualities so we had the model shop paint and polish to simulate a molded plastic finish.” Models also needed to match the weight of the prototype handset as closely as possible for the study to be reliable.<sup>75</sup>

<sup>74</sup> Ibid.

<sup>75</sup> Ibid.

The four main components of the production Trimline phone are the rotary-dial and touchtone handsets and the desk and wall bases (fig. 44). The rotary-dial Trimline was introduced in 1965, and the touchtone Trimline was introduced in 1966. These handsets contained all circuitry except the ringer and were used interchangeably with either the desk base or the wall base such that Western Electric stocked the four components separately



Fig. 37. Western Electric dial-in-handset (Shmoo) telephone, 1959. (Paul Fassbender.)

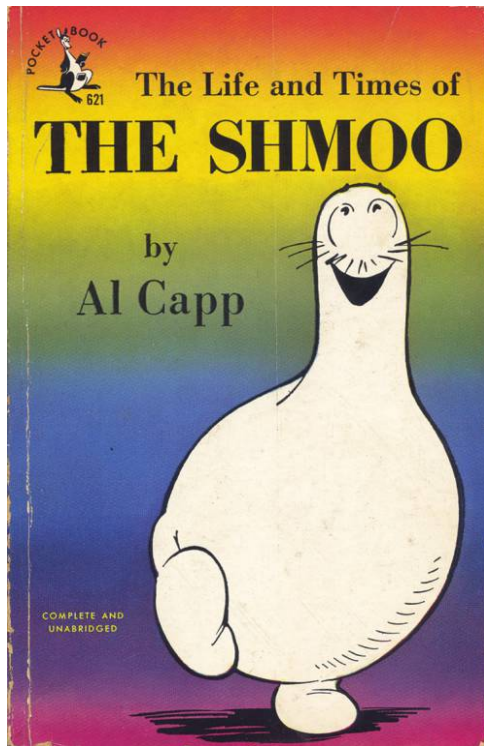

Fig. 38. Cover, Al Capp, *The Life and Times of the Shmoo* (New York: Pocket Books, 1949).

rather than stocking whole telephones.<sup>76</sup> The original touchtone Trimline (see fig. 44) had only ten buttons; the star and pound keys were added later.

Another drawing by Tilley shows the Trimline handset with dimensions and a graphical display of the data distribution (fig. 45). In this drawing the modal distance (5.625 or  $5\frac{5}{8}$  inches) is the same as for the G-type handset although the angles differ. The graphic in figure 45 is the same (with the image flipped about the vertical axis) as the one in figure 20, which matched the 1920s data used in designing the early E-type handset. Thus no new head measurements were taken or detailed analyses made during the intervening decades.

A characteristic of all Dreyfuss-related desk-set telephone designs was a feature allowing the user to pick up the phone with one hand straddling the handset. Grasping of the Trimline desk set is made possible by the reverse draft (inward-sloping sides) of the base exterior, which involved a rather complicated die (fig. 46, left). This reverse draft, opposite that of the wall base (see fig. 46, right), results

<sup>76</sup> Krumreich and Mosing, "The Evolution of a Telephone," 14.



Fig. 39. Western Electric Contour telephone, 1960. (Paul Fassbender.)

in the desk base's unusual cross-section, which is thicker at the top than at the bottom.<sup>77</sup> In the Trimline, the very small lip around the desk base is merely a parting line in the mold. The reverse draft in the desk base also gives it a unique sculptural appearance by rolling under, which contributes significantly to the perception that the phone has a high degree of finish and subtlety.

Like other wall phones designed in Dreyfuss's office, an off-hook handset could be parked on the wall-mounted base. In each case, this feature was added by Genaro. The Trimline handset rested on a shoulder or fin on the top edge of the original (AC1) wall-mounted base (fig. 47). Just three years after the Trimline was introduced, however, a patent application was filed for a revised housing for the wall-mounted base.<sup>78</sup> This housing (fig. 48) was used on the AC2 and AC3 wall-mounted bases. Although the patent suggests that this base could be used either as a vertical wall base or a horizontal desk base, Genaro points out that the design was never intended to be used in a horizontal position.<sup>79</sup> In fact, the design is quite susceptible to the undesirable receiver-off-hook condition when placed in a horizontal position. In the patent (figs. 49, 50) there is no side view in the vertical orientation, so it seems likely that the patent attorneys merely rotated that view and claimed it was "a side view of the

<sup>77</sup> The cross-sections in figure 40 were traced by the authors from Trimline specimens, which were cut at a midplane. The outer shapes of the dies are for illustration only and are not accurate.

<sup>78</sup> Henry Dreyfuss, Donald M. Genaro, Gordon E. Sylvester, and Stephen W. Walden, "Telephone Handset Support," *United States Patent* (des. 216,427, filed December 31, 1968).

<sup>79</sup> Donald Genaro, email to authors, September 15, 2017, 10:21 am.

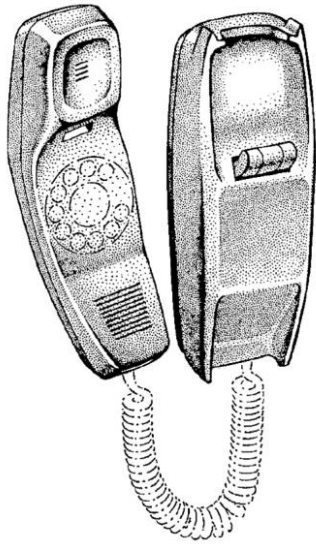

Fig. 40. Patent drawing Trimline-I, detail of fig. 1 from Lionel W. Mosing (assignor to Bell Telephone Laboratories), "Combined Telephone Handset and Stand," patent D189, 877, filed 1960. (US Patent and Trademark Office.)

handset support in an alternate position." A benefit of the revised design is a more stable location for the off-hook handset rest by virtue of the design's larger shoulders and raised sideboards. This increased stability comes at the price of a more angular shape that loses its unity with the flowing lines of the handset. It also contrasts with Genaro's approach of making the handset's temporary perch require careful placement on a slightly less than secure surface so that users made a mental note that they'd left the phone off the hook.

The Trimline has a dial light but no night light. As in the Princess, the light was originally an incandescent bulb that required power from a baseboard transformer via an extra pair of wires in the line cord and in the handset cord. The five wires in the handset cord required a special, thicker-than-usual handset cord for Trimline telephones.

A second generation of production Trimlines had line-powered light-emitting diodes (LEDs), rather than incandescent lights. Although this feature required a significant circuit modification, it eliminated the need for an extra pair of wires in the line cord and the baseboard transformer.<sup>80</sup>

<sup>80</sup> Meyer, *Old-Time Telephones! Design, History, and Restoration*, 179–80.



Fig. 41. Henry Dreyfuss's conference room with dial-in-handset Trimline predecessors in chronological order, 1962. (Henry Dreyfuss Associates.)

The LEDs and the elimination of party-line calling reduced the number of wires in the handset from five to two so that the same four-wire handset cord with standard modular plugs could now be used on all the modular-corded Bell System telephones. In the mid-1970s, the Bell System began using handset and line cords with modular connectors.<sup>81</sup> Existing phones beginning with the 500s were backfitted with these cords. In practice, the second generation Trimlines were thus easier to install and less expensive.

The only appearance difference in the second-generation Trimline handset with a rotary dial was the addition of the letters, LED, on the number plate. On Trimline handsets with touchtone dials, however, square buttons on a flat panel replaced the round buttons on a curved panel of the earlier sets. The curvature of this earlier panel (fig. 51) is the same as the curvature of the handset itself. In fact, the tops of the buttons also follow the curvature of the handset (compare the tops of the buttons with the side of the handset). This curved detail of the early touchtone Trimline handset resting on the reverse-draft desk base represents the pinnacle of achievement for Genaro's Trimline sculpture.

Like the Princess telephone, the Trimline was copied by other manufacturers using various trade names. Many parts were interchangeable between the Bell System's Trimline, Kellogg's Trendline, and Stromberg-Carlson's Slenderet, and the three phones were almost indistinguishable in appear-

<sup>81</sup> Edwin C. Hardesty, Charles L. Krumreich, Albert E. Mulbarger, Jr., and Stephen W. Walden, "Devices for Making Electrical Connections," *United States Patent* (des. 3,699,498, filed April 30, 1970).

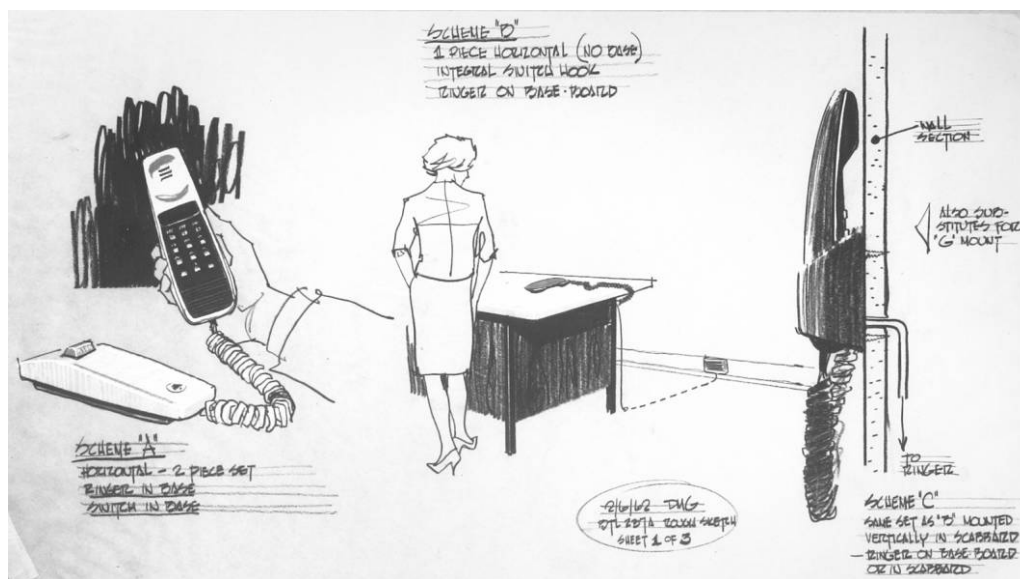

Fig. 42. Sketch, Donald Genaro, general Trimline design approaches, 1962. (Henry Dreyfuss Associates.)

ance. Automatic Electric's Styleline was a little different but followed the same format.

### Design Line Series

In 1968, a tri-company project team was formed consisting of AT&T marketing and customer services specialists, Western Electric merchandising and manufacturing experts, and Bell Labs engineers.<sup>82</sup> The team's purpose was to develop "antique/decorator" concepts into new products and find ways to compress the timeline for products to reach the market. The design requirements specified by the team were straightforward: the telephones must be unusually attractive; use standard, available components; and appeal to a broad range of customers interested in decorator-style telephones, from the low-price mass market to the high-fashion, exclusive market.

Bell Labs engineers called on Dreyfuss's firm to develop a series of new-style telephones in unique shapes, materials, and colors. Other designers were later brought into the program. The new products were called Design Line telephones. For these phones, the customer would purchase a Bell System-approved housing from a retail outlet, but the Bell System would own the components neces-

sary to make it a working telephone set. Bell billed the customer at the regular monthly extension rate for service, where applicable. Although the housings were made by a variety of contractors, the telephones were assembled by Western Electric and equipped with Western Electric working parts.

The total number of eventual designs and variations in the Design Line series is not known by the authors but reached more than fifty—eventually including candlesticks, Disney characters, Snoopy, and Kermit the Frog. The Dreyfuss designers did

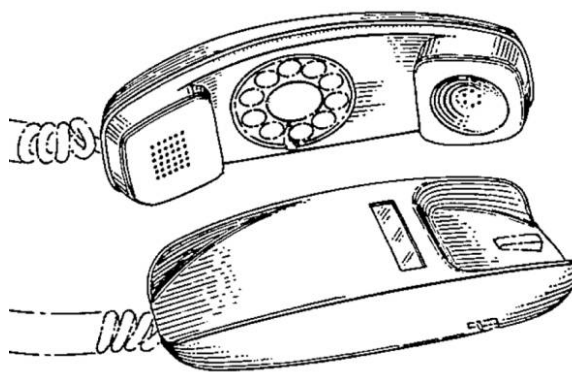

Fig. 43. Patent drawing of Donald M. Genaro's Trimline-II field trial design, detail of fig. 12 from Henry Dreyfuss, Lionel W. Mosing, and Robert E. Prescott (assignors to Bell Telephone Laboratories.), "Combined Telephone Handset and Stand," patent D202,787, filed 1964. (US Patent and Trademark Office.)

<sup>82</sup> Norris R. Hall, "Design Line Decorative Telephones: Just the Beginning," *Bell Laboratories Record* 53 (May 1975): 235-41.



Fig. 44. Main components of early production Trimline telephones, showing (left to right) desk base, rotary handset, touchtone handset, and wall base, 1965–66. (Gregg Museum of Art and Design.)

not consider these phones to be a high-water mark of consumer taste as they critiqued the lineup from candlesticks to phones in the likeness of mice and dogs (Mickey and Snoopy).<sup>83</sup> Faced with this frivolous product line, Genaro describes the firm's efforts as trying to make the designs submitted by their office as sensible as possible.

Prior to the Design Line, the last telephones that were personally designed by Henry Dreyfuss were the Shmoo and its derivative, the Contour. Both were design failures. But these failures gave Dreyfuss's rising star Genaro a chance to reach his potential with the truly exceptional Trimline desk telephone. Just before his retirement, Dreyfuss tried again with three designs that were intended for the Design Line collection (figs. 52–54).<sup>84</sup> These designs, with their Trimline handsets resting on slabs, were never produced for sale by the Bell System.

Before the start of the program, the Bell System conducted a survey of possible entries. Photos of models and sets made by others (some suitable for a French bordello) were pictured on a questionnaire soliciting consumer preference.<sup>85</sup> The Dreyfuss

firm submitted several hundred sketches for consideration by the Bell System, and Genaro had over-

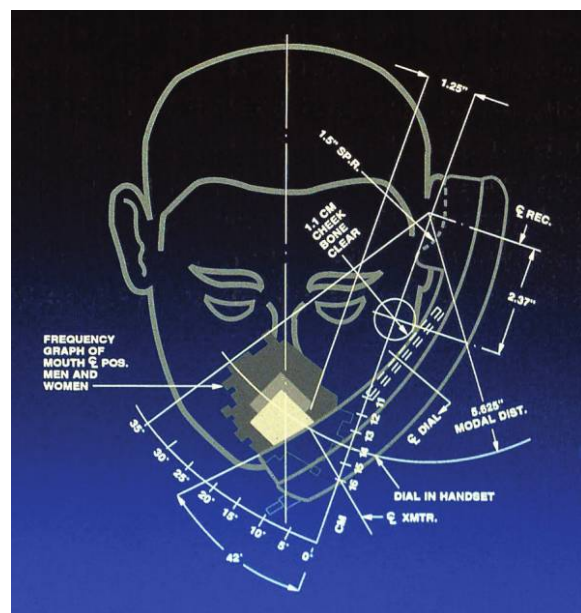

Fig. 45. Drawing, Alvin Tilley, Trimline handset with head dimensions and frequency data, ca. 1990. (Henry Dreyfuss Associates.)

<sup>83</sup> Donald Genaro, email to authors, August 11, 2016, 1:22 pm.

<sup>84</sup> Donald Genaro, email to authors, August 5, 2016, 12:44 pm.

<sup>85</sup> Donald Genaro, email to authors, August 11, 2016, 1:22 pm.

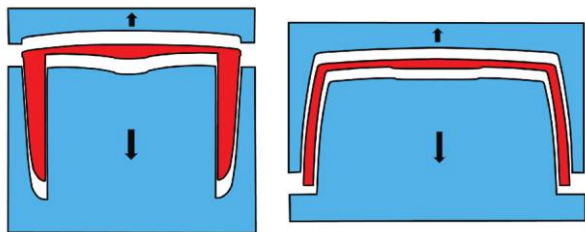

Fig. 46. Trimline base central cross sections (red) and molding dies: desk base (left), wall base (right). (Ralph Meyer.)

sight on all of them.<sup>86</sup> The Design Line series was introduced in 1973 with a group of five phones, all of which were designed by the Dreyfuss firm: Accent, Celebrity, Elite, Exeter, and Stowaway.<sup>87</sup> Henry Dreyfuss Associates, the firm's name after Dreyfuss retired, produced seven more of the Design Line phones: Big Button, Country Junction, Country Squire, Director, Noteworthy, Sculptura, and Telstar. Genaro designed Stowaway, Noteworthy, Sculptura, and Telstar. The rest were designed by John McGarvey and Gordon Sylvester; Alvin Tilley, the firm's design engineer, played a significant role in the design of all of them.

The Exeter (fig. 55) was the most practical of the Design Line offerings and shows a lasting example of the Dreyfuss firm's work. Desk versions (No. 900 rotary, 2900 touchtone) and wall versions (No. 953 rotary, 2953 touchtone) were available. Many later business phones were variations of this design theme.

The K-type handset on the Exeter and some other Design Line phones was designed by Genaro and manufactured by Western Electric, although the rest of the housing was made by an independent contractor.<sup>88</sup> Genaro reports that on a visit to Indianapolis while watching the molding and assembly of the iconic G-type handset, he thought "there's got to be a better, faster and less expensive way (and better looking). I might have been seen as attacking mom & apple pie, but with many of the sets I was beginning to work on (mostly business sets), the old dumbbell look of the G and round pockets troubled me." Appearance upgrades could be achieved by simply substituting the G with a K, making for a crisper, contemporary look. The K-



Fig. 47. Trimline off-hook handset on original wall-mounted base (AC1), 1965. (Gregg Museum of Art and Design.)

type design with its carbon transmitter was patented and eventually transformed into the similar-looking R-type handset with an electret transmitter that was used on many later business sets.<sup>89</sup> Our measurements show that the modal distance and angles on the K-type handset were identical to the G-type handset, although the handle cross-section was slightly different.

## Conclusions

Recent discoveries described in this publication correct three major errors in design history scholarship on Dreyfuss telephone designs resulting from reliance on nonprimary reference sources. As a result of these types of errors, historical accounts to date have given too much personal credit

<sup>86</sup> Donald Genaro, email to authors, September 8, 2016, 1:33 pm.

<sup>87</sup> Hall, "Design Line Decorative Telephones," 236, 240.

<sup>88</sup> Donald Genaro, email to authors, July 31, 2016, 1:54 pm.

<sup>89</sup> Donald Michael Genaro and John Niel McGarvey, "Telephone Handset," *United States Patent* (des. 229,837, filed April 13, 1973).



Fig. 48. Trimline off-hook handset on revised wall-mounted base, ca. 1968. (Ralph Meyer.)

to Henry Dreyfuss for Bell System telephones and too little to members of his talented staff—especially Robert Hose and Donald Genaro—and have completely overlooked George Lum, the prolific and capable designer at Bell Labs. Although we identify Dreyfuss as principal designer of only one of the telephone items (the G-type handset), it should be kept in mind that by the 1950s, his managerial duties and responsibilities as principal limited his actual design time.

The manner in which he presented his firm's designs to clients was unique to Henry Dreyfuss,

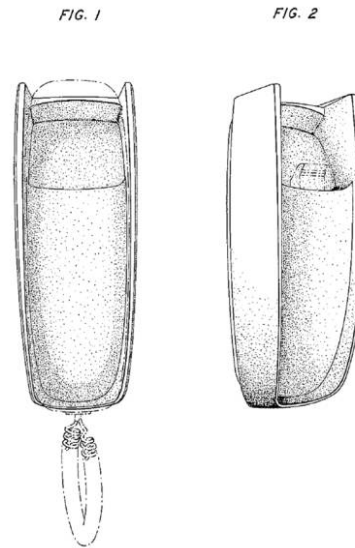

Fig. 49. Patent drawing of revised Trimline base, detail of fig. 1 front view and fig. 2 front perspective view from Henry Dreyfuss, Donald M. Genaro, Gordon E. Sylvester, and Stephen W. Walding (assignors to Bell Telephone Laboratories), "Telephone Handset Support," patent D216,427, filed 1968. (US Patent and Trademark Office.)

the master of the lost art of the soft sell. The showmanship was in his manner and word choice, although occasionally it involved props and drama, as in one complex presentation for Polaroid where he assembled a camera model out of components taken from a vest with extra pockets. Most of Dreyfuss's script—which no other firm could equal—existed in his head alone. And every associate inter-

FIG. 3

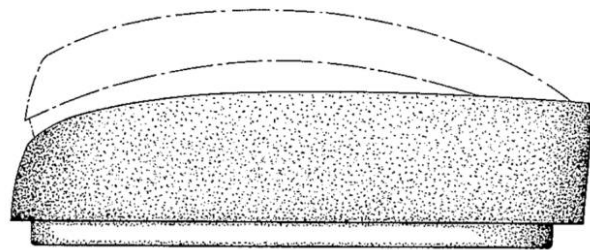

Fig. 50. Patent drawing of revised Trimline base, detail of fig. 3 side view from Henry Dreyfuss, Donald M. Genaro, Gordon E. Sylvester, and Stephen W. Walding (assignors to Bell Telephone Laboratories), "Telephone Handset Support," patent D216,427, filed 1968. (US Patent and Trademark Office.)



Fig. 51. Early round-button touchtone Trimline handset, 1966. (Ralph Meyer.)

viewed said they could not match him as a salesman nor had they met anyone who could. Dreyfuss had a subtle charisma, and he knew it.

Dreyfuss's practice of working closely with engineers in designing products proved successful but often was fraught with tension. In spite of the cool feelings between Dreyfuss and former Bell employee Hose and outright anger at Bell Labs for its clandestine efforts on the Trimline, this joint effort between designer and engineer produced some of the best designs of the twentieth century.

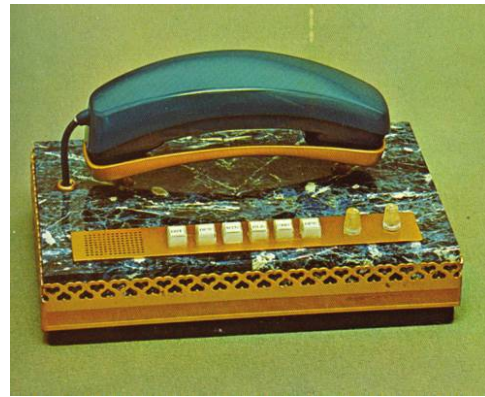

Fig. 53. Design Line prototype with rectangular marble base, ca. 1968. (Henry Dreyfuss Associates.)



Fig. 54. Design Line prototype with rectangular metal base, ca. 1968. (Henry Dreyfuss Associates.)

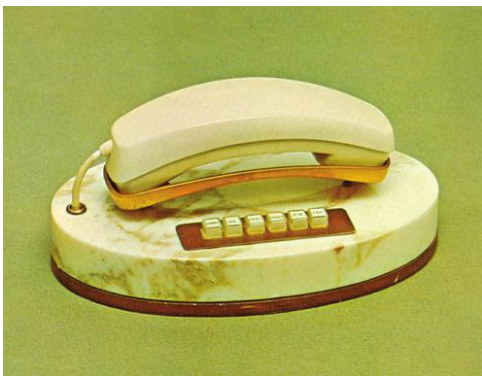

Fig. 52. Design Line prototype with oval marble base, ca. 1968. (Henry Dreyfuss Associates.)



Fig. 55. Western Electric Design Line Exeter, 1973. (Ralph Meyer.)