

INFORMATION
FOR THE
CARE AND OPERATION
OF
No. 1317 Telephone Sets

Western Electric Company

TABLE OF CONTENTS

	Page
ASSEMBLING NO. 1317 TELEPHONE SETS.....	6
Mounting the Transmitter.....	6
Mounting the Switchhook and Receiver.....	8
Generator Crank.....	9
Writing Shelf.....	9
INSTALLING NO. 1317 TELEPHONE SETS.....	10
Protectors.....	10
Connecting the Telephone Set.....	11
Ground Connection.....	12
Connecting the Dry Cells.....	14
ADJUSTING NO. 1317 TELEPHONE SETS.....	15
Ringer Adjustment.....	15
How to Install a Condenser.....	16
TESTING NO. 1317 TELEPHONE SETS.....	18
How to Make Test.....	18
HOW TO CLEAR TROUBLE.....	19
ACCESSORIES AND REPLACEMENT PARTS..	23

INFORMATION
FOR THE
CARE AND OPERATION
OF
NO. 1317 TELEPHONE SETS

The No. 1317 type telephone sets are magneto telephone sets arranged for wall mounting.

To facilitate shipping, certain parts of the set are packed inside of the case instead of assembled on the set and such parts should be assembled in accordance with the instructions in this bulletin. The parts which are ordinarily detached from the set and packed inside of the case are shown in Figure 1.

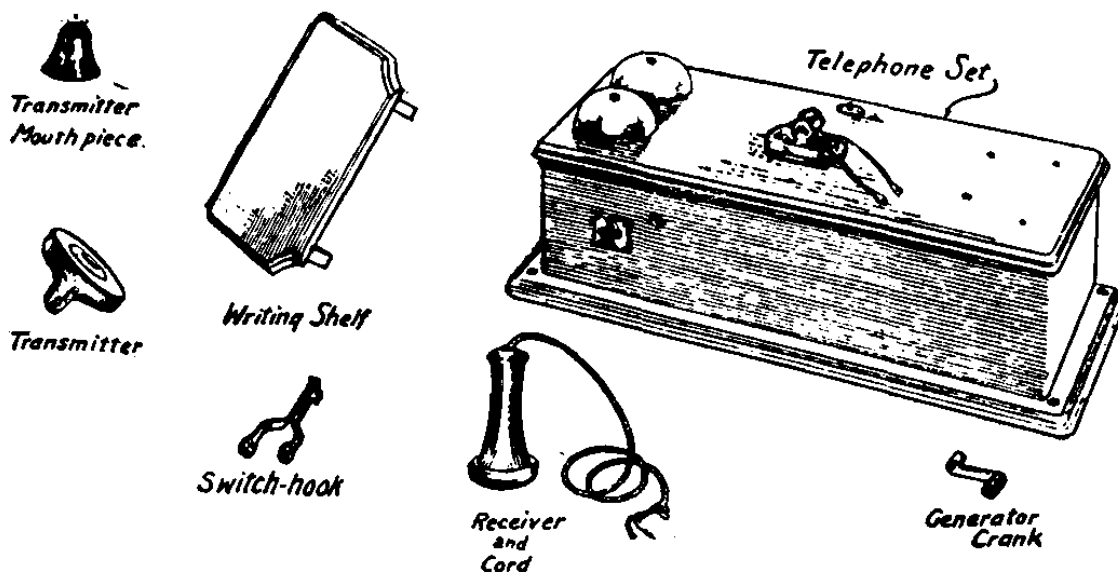

FIG. 1—SET UNPACKED READY FOR ASSEMBLING

ASSEMBLING NO. 1317 TELEPHONE SETS

Mounting the Transmitter

Remove the bolt, screw, and washer from the lug on the back of the transmitter. Remove the four small screws around the rim of the transmitter and remove the front of the transmitter.

Bring the two small cords, on the inside of the door, out between the lugs of the transmitter bracket as shown in figure 2 and then insert the lug of the transmitter between the lugs of the transmitter bracket in such a way that the oval opening in the lug is on the downward side (see figure 2).



FIG. 2—MOUNTING THE TRANSMITTER

Insert the bolt through the bracket and the transmitter lug in such a way that the small projection under the head of the bolt will fit into the notch in the bracket. Fasten the bolt in place by means of the spring

washer and mounting bolt screw (see figure 16).

Pass the two cords up through the oval opening in the transmitter lug and fasten them to the binding posts on the rear of the transmitter face plate (see figure 4). If the transmitter is equipped with a factory test clip (see figure 3), this should be removed before connecting the cords. Replace the front of the transmitter in such a position that the nameplate will be below the mouth piece and then replace the four screws that were removed from the rim of the transmitter when it was taken apart.

FACTORY TEST CLIP,
REMOVE & DISCARD

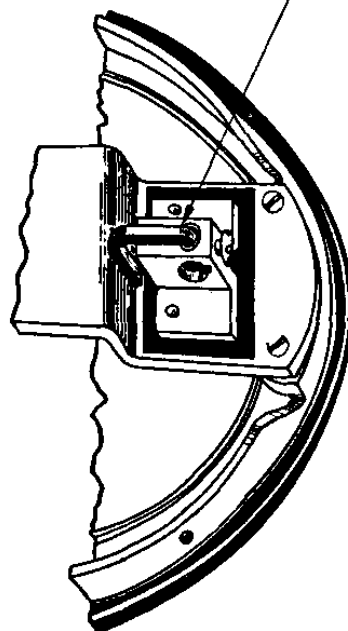

FIG. 3
TRANSMITTER
EQUIPPED WITH
FACTORY TEST CLIP

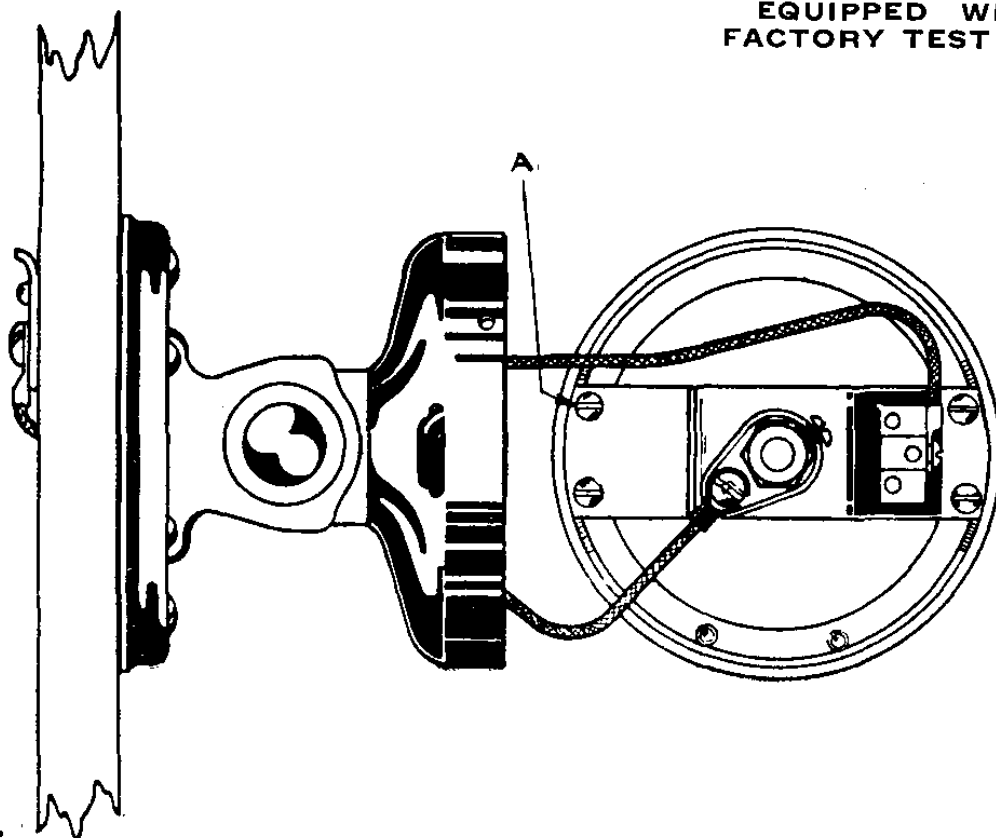

FIG. 4—SHOWING REAR OF TRANSMITTER FACE PLATE

Screw the mouthpiece into the front of the transmitter.

Note: On sets having three transmitter cords on the inside of the door, the black cord is used to ground the frame of the transmitter. This is done by passing the black cord up through the hole in the back of the transmitter, together with the other cords, and fastening it under the screw marked "A" (see figure 4) on the rear of the transmitter face plate.

Mounting the Switchhook and Receiver

The switchhook is mounted by means of the fulcrum pin in the bracket shown in figure 6. To assemble the switchhook, remove the fulcrum pin from the bracket by pressing on the end of the pin which is nearest the back of the box.

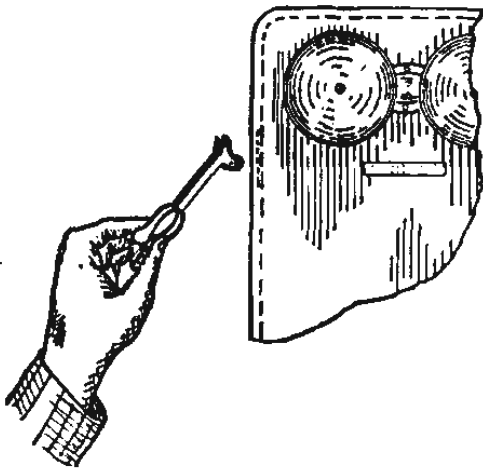

FIG. 5—METHOD OF INSERTING SWITCHHOOK

Hold the switchhook with the roller downward and insert it roller first through the slot in the upper left-hand side of the box (see figure 5). Holding the switchhook against the top of the slot in the box, press the roller against the large hook-

shaped spring; match up the hole through the end of the switchhook with the corresponding holes in the spring bracket inside of the set; and fasten by inserting the switchhook fulcrum pin through the holes (see figure 6). If the fulcrum pin sticks when partly in, work

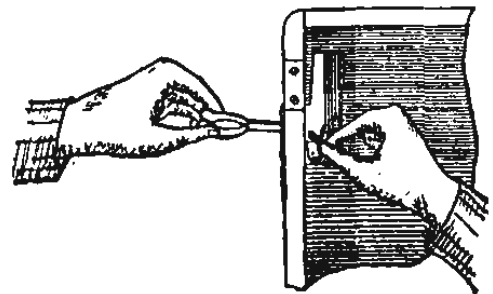

FIG. 6—FASTENING SWITCHHOOK WITH FULCRUM PIN

the switchhook up and down until the pin slips through.

To connect the receiver, place it on the switchhook and push the ends of the receiver cord through the small hole in the left-hand side of the set, below the switchhook. Loosen the screws on the two terminals marked "REC" (see figure 7), insert the tips of the cord underneath the heads of the screws and tighten the screws securely. Either cord tip may be connected to either of the terminals marked "REC." Tie the stay-cord to the screw-eye on the inside of the set so that if the receiver cord is pulled there will be no strain on the cord terminals.

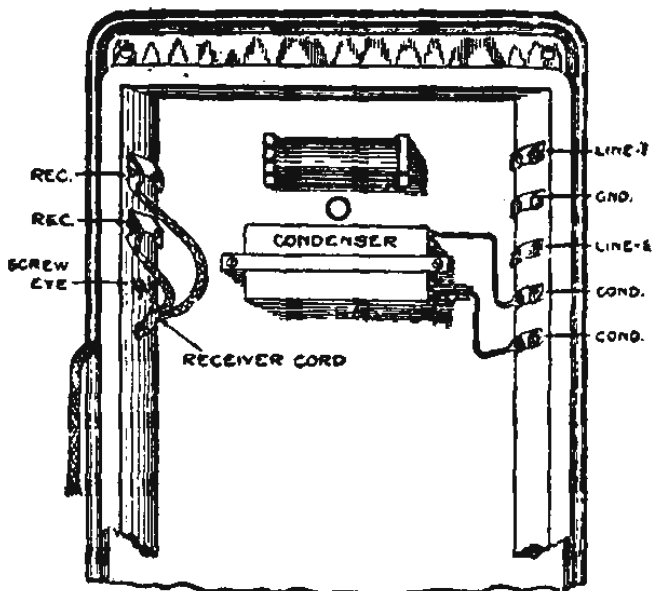

FIG. 7—METHOD OF CONNECTING THE RECEIVER. (THIS FIGURE ALSO SHOWS THE LOCATION AND METHOD OF CONNECTING THE CONDENSER IN THREE BATTERY SETS).

receiver cord is pulled there will be no strain on the cord terminals.

Generator Crank

Insert the generator crank through the hole in the right-hand side of the box and screw it on to the end of the generator shaft.

Writing Shelf

If the writing shelf is shipped unassembled, fasten it to the door of the set as shown in figure 8, by means of the four wood screws which are packed with the set for this purpose.

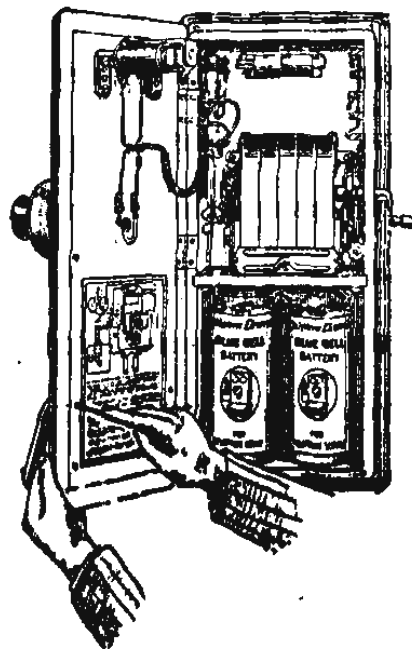

FIG. 8—SECURING WRITING SHELF TO DOOR.

INSTALLING NO. 1317 TELEPHONE SETS

Protectors

Protectors are not furnished with the set, but should be used in order to protect the telephone apparatus from lightning, electric light circuits, and power circuits, and should generally be located inside the building at the point where the line wires enter. When it is necessary to mount the protectors on the outside of the building, they should be protected by a suitable cover. By locating the protectors at a point not directly on the telephone sets, the danger of personal injury, fire and accidental grounding is reduced to a minimum.

When the protector is connected in the circuit (as shown in figures 10 or 11), abnormally high potential currents such as might be impressed on the line from lightning, tend to jump to the ground instead of entering the telephone. This ground connection, therefore, pro-

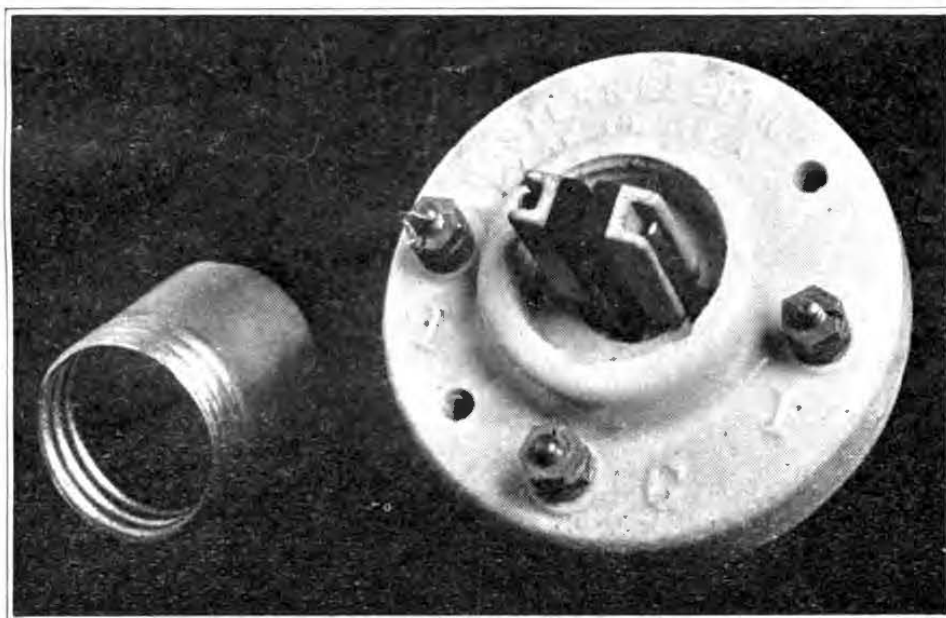

FIG. 9—NO. 60-AP PROTECTOR

vides adequate protection in localities where there are no electric light or power circuits.

The No. 60-AP protector (see figure 9) is of the open space cut-out type. It consists of a base and cover, mounting 4 protector blocks. Two of the protector blocks are of carbon and are assembled nearest the center of the protector. The other two protector blocks consist of carbon inserts mounted in porcelain in such a manner that they are slightly depressed below the surface of the porcelain on the side adjacent to the plain carbon block, thus forming the open space across which high potential currents may escape to the ground. The porcelain blocks containing the carbon inserts are placed outside the other blocks with the springs resting in the grooves (see figure 9).

If there is danger from power and light circuits as well as from lightning, the No. 58-AP protector or the No. 58-B protector, which contain fuses in addition to the open space cut-outs, should be used. The No. 58-AP protector uses the same type of protector blocks as the No. 60-AP protector. The No. 58-B protector employs four metal blocks, two of which are grooved and are assembled outside of the other blocks, with the springs resting in the grooves. A specially prepared piece of mica, known as a No. 10 protector mica is assembled between each pair of metal blocks.

Connecting the Telephone Set

The telephone line wire should be connected to the protector as shown in figure 10 in the case of a metallic

two wire telephone line or as shown in figure 11 in the

case of a grounded or one wire telephone line. Then connect the terminals of the protector to the terminals of the telephone set as shown on the respective figures. No. 19-B & S gauge, twisted pair, copper wire, with braid and rubber insulation, is generally used for this purpose. This wire should be secured in place with insulated clamps, nails or staples. Pass the ends of the wires through the hole in the back of the telephone set and fasten the set securely to the

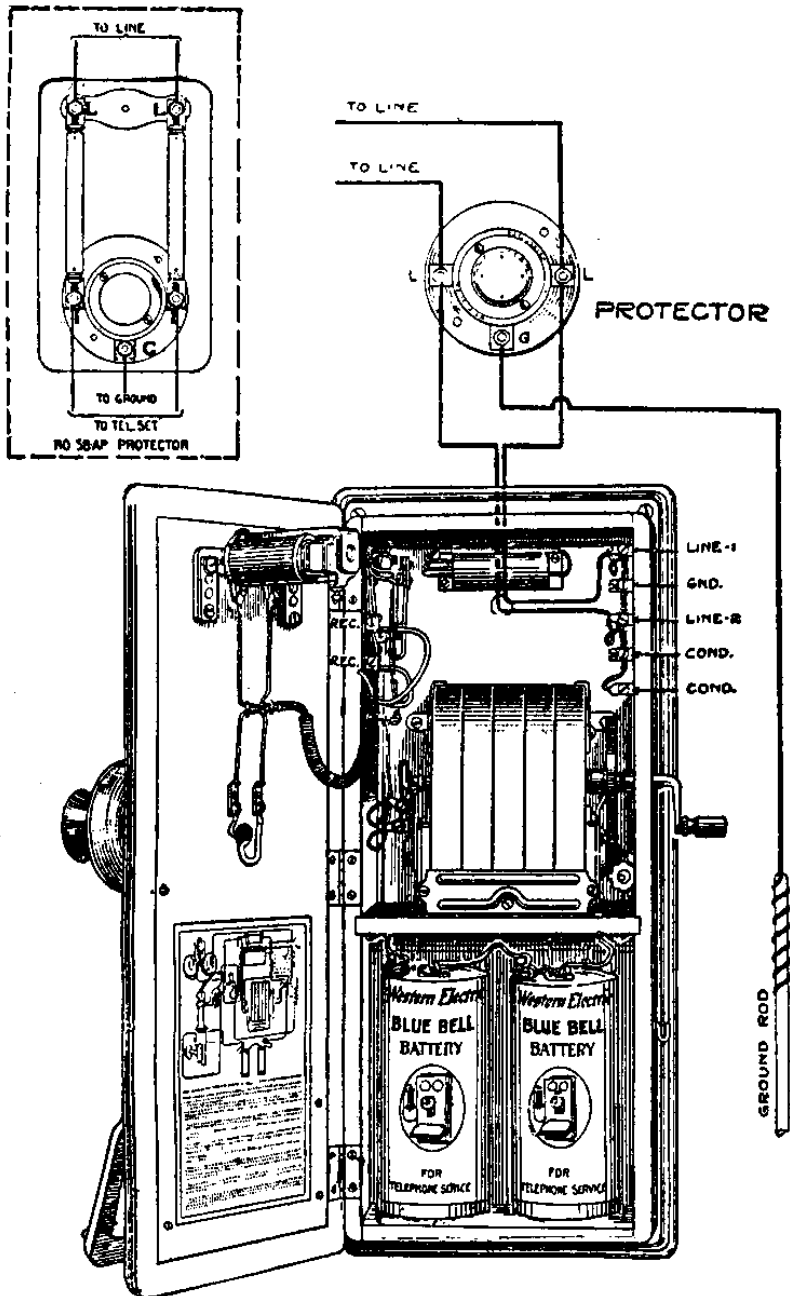

FIG. 10—METHOD OF WIRING SET AND PROTECTOR ON A METALLIC LINE

wall, running the wires through the slot in the back of the set.

Ground Connection

It is important that the ground connection be

carefully and permanently made, as otherwise the pro-

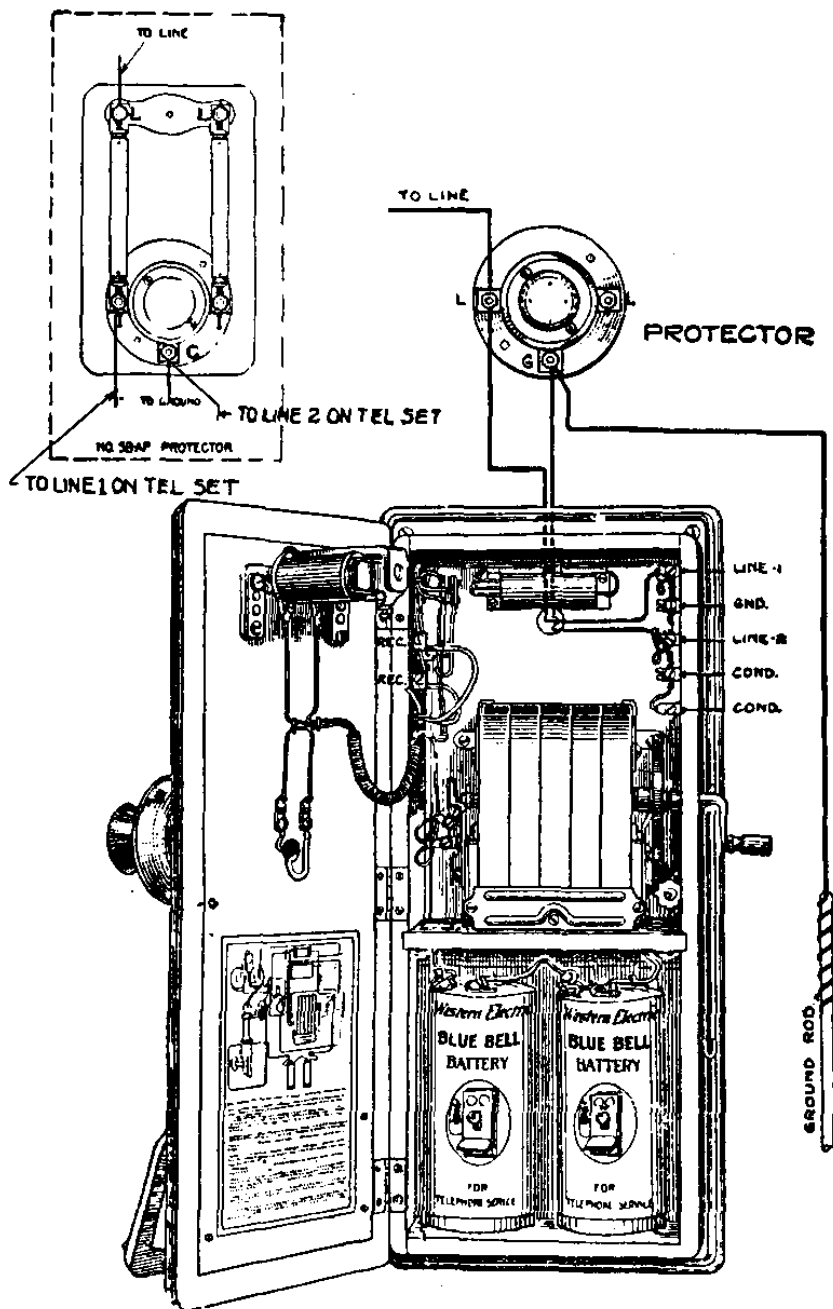

FIG. 11—METHOD OF WIRING SET AND PROTECTOR ON GROUNDING LINE

jector may not be of any value. Ground connections may be made by means of a ground rod or a ground clamp on a water pipe. The ground rod (this may be obtained from the nearest distributor listed in this bulletin) or an iron rod about 6 feet long by $\frac{1}{2}$ " in diameter should be driven securely into permanently moist ground near the building where the telephone set is being installed. Connect a wire to the ground rod and to the terminal on the protector marked "G" (see figure 11).

Copper wire not smaller than No. 18 B&S gauge, with braid and rubber insulation, should be used for this purpose.

In order to make a good connection with the ground rod, clean the surface of the rod and then twist the bare wire around the rod five or six times and solder.

If it is desired to use a water pipe for the ground connection, a ground clamp should be fastened securely to the water pipe or to some other pipe which makes a good connection with the ground. Clean the pipe thoroughly so that a good electrical contact may be made, then fasten the ground clamp securely to the pipe and solder the ground wire to the clamp.

The ground wire should be led with as few bends as possible from the protector to the ground connection.

Connecting the Dry Cells

The dry cells should be connected in series, i.e., connect the center terminal of the first cell to the outside terminal of the second cell (in the case of three cell sets, also connect the outside terminal of the third cell to the center terminal of the second cell). The remaining two terminals should be connected to the two wires which extend into the battery compartment (see figure 12), as shown on the circuit label pasted on the inside of the cover.

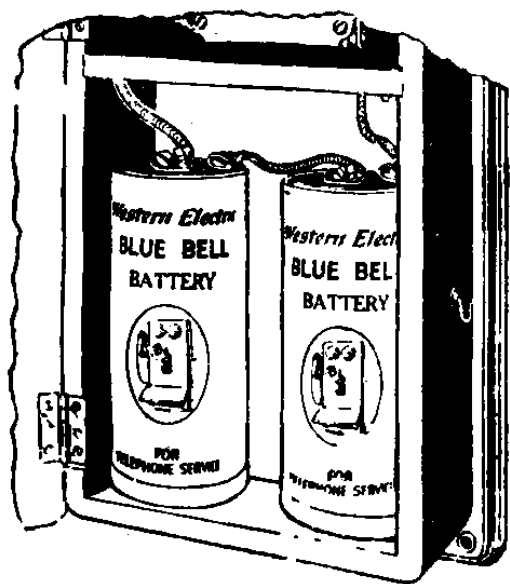

FIG. 12—METHOD OF CONNECTING BATTERIES

ADJUSTING NO. 1317 TELEPHONE SETS

When the telephone set leaves the factory, all parts are adjusted to operate satisfactorily under ordinary conditions. The apparatus need not be disturbed unless it does not operate properly, but if it is necessary to change the adjustment, the following rules should be observed:

Ringer Adjustment

The movement of the clapper ball of the ringer shown in figure 13 should be $1/16''$. If the movement requires adjustment, turn the screw "A" (see figure 13) to the right to shorten the stroke, or to the left to lengthen the stroke, until a movement of $1/16''$ is obtained.

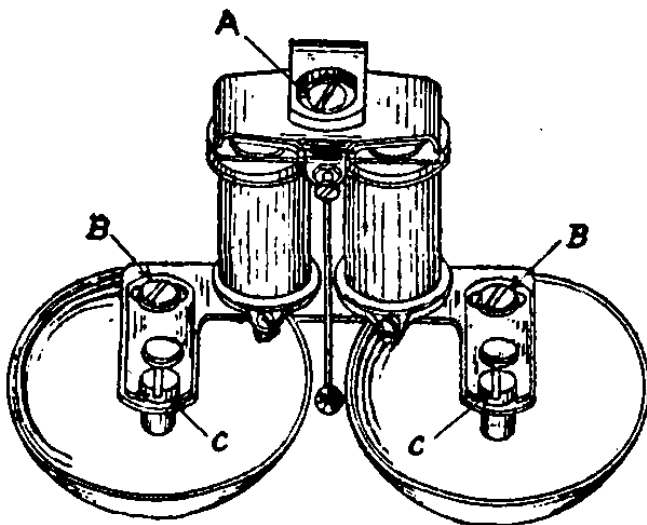

FIG. 13—ADJUSTMENT OF RINGER HAVING SCREW "A"

The clapper ball should strike the gongs but should not rest against them when thrown to either side.

The adjustment for this may be made by loosening the two clamping screws "B" and turning the two eccentric screws "C" until the correct position is obtained. Then tighten the clamping screws "B" (see figure 13).

Note: In case the ringer is of the design shown in figure 14, the movement of the clapper ball should be $5/64''$. If the movement requires

adjustment, raise or lower the armature yoke "D" by means of the nuts "A" and "B", taking care to keep the yoke at right angles to the post supports. When the correct position is obtained, clamp the yoke firmly between the nuts.

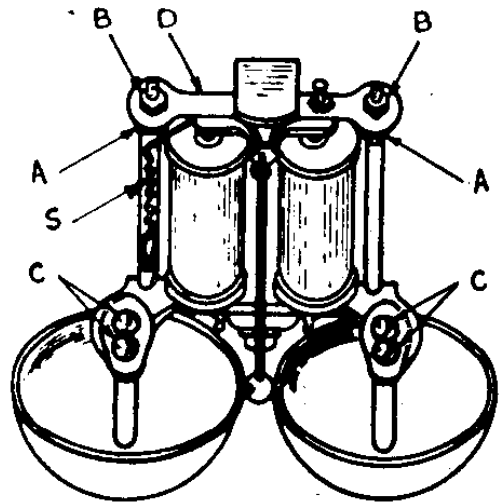

FIG. 14—ADJUSTMENT OF RINGER BY MOVING ARMATURE YOKE

The gongs should be so set that the clapper ball strikes but does not rest against them when thrown to either side. To change the position of the gongs, loosen the clamping screws "C" (see figure 14) and push the gongs, by hand, together or apart, as desired, until the correct position is obtained, then tighten the clamping screws "C."

If the ringer is equipped with a biasing spring "S" as shown in figure 14 (i.e., a spring which holds the clapper ball toward one of the gongs), the tension of the spring should be such that when the armature is forced away from the pole-piece against which it normally rests, and is returned by the spring tension, the clapper ball will strike the gong, but will not rest against the gong. The tension of the spring is adjusted by turning the adjusting stud to which one end of the spring is fastened.

How to Install a Condenser

It is sometimes desirable to connect a condenser in series with the receiver in order to insure that the bell can be rung even if the receiver is left off the hook. Instructions are given below as to the method of con-

necting the condenser, as some of the No. 1317 telephone sets are furnished without condensers.

To connect a condenser in sets having three batteries, remove the yellow covered wire (with the forked tip) from the lower of the two terminals marked "COND" and connect it to the upper one of these terminals. Mount the condenser in the upper compartment and connect it to the two terminals as shown in figure 7.

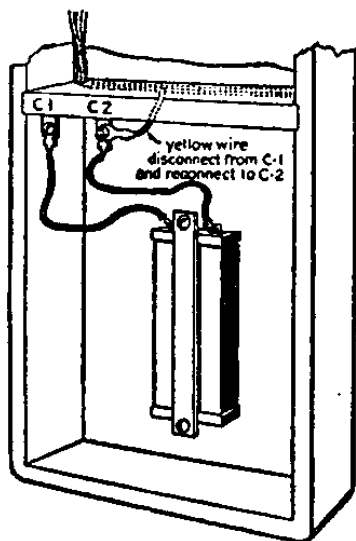

**FIG. 15—METHOD OF
INSTALLING CON-
DENSER IN TWO
BATTERY SET**

In the two battery type of set, the condenser should be fastened in the lower compartment and connected as shown in figure 15. The yellow covered wire (with the forked tip) should be removed from terminal C1 and connected to terminal C2.

TESTING NO. 1317 TELEPHONE SETS

How to Make Test

After installing the telephone set, it should be tested as follows:

1. Turn the handle of the generator. This should cause the bell to ring.

2. Take a short piece of wire and connect one end to the terminal marked "Line 1" (or "L1") and the other end to the terminal marked "Line 2" (or "L2"). Turn the handle of the generator. It should now turn harder than before and the bell should not ring.

3. Leave the short piece of wire connected to "Line 1" and "Line 2." Take the receiver off the hook and hold it to the ear. Then talk into the transmitter or move the switchhook up and down. Sounds should be heard in the receiver.

If the above tests show the telephone set to be in proper working condition, remove the short piece of wire mentioned above and connect the two wires of the telephone line to the terminals marked "Line 1" and "Line 2" (or "L1" and "L2") as shown in figure 10. When there is only one wire, connect as shown in figure 11.

The telephone set is now connected and ready for use. To call central or subscribers on the same line, give the handle of the generator two or three turns. If there are a number of subscribers on the same line, a pre-arranged code of signals is necessary, usually a series of long and short rings to indicate which subscriber is being called.

HOW TO CLEAR TROUBLE

If the telephone set does not work properly, the trouble may be out on the line, in the interior wiring in the building, in the ground connection or in the telephone set. The following paragraphs outline various possible troubles and the methods to be used in correcting them:

1. You cannot ring up anyone. Your generator handle turns hard. Your bell does not ring when you turn the generator handle.

When testing to discover the cause of this trouble be sure to leave the receiver on the switchhook.

Disconnect the two wires, which enter the telephone set, from the terminals marked "Line 1" and "Line 2" (or "L1" and "L2") and make sure that the wires leading from the ringer are tightly connected to these terminals. Turn the generator handle. If the handle turns easily and the bell on the telephone set rings, the trouble is not in the telephone set. Connect the line wires again to the terminals marked "Line 1" and "Line 2" (or "L1" and "L2") and disconnect the line wires from the protector. The wires from the telephone set to the protector should not be removed. Turn the generator handle and if it turns hard, remove the protector blocks from the protector and then turn the generator handle again. If it turns easily, examine the protector blocks to see that they have not been damaged so that the carbon insert touches the adjacent carbon block when mounted in the protector. Clean the protector blocks with a stiff brush and put them back into the protector. (In the case of the No. 58-B protector, be sure to place the thin piece of mica between them). After replacing the blocks, turn the generator handle again and if it operates easily, connect the line wires to the protector and then see if the telephone set works properly.

If, after the protector blocks have been replaced, the generator handle turns easily when the line wires are disconnected at the protector, but turns hard when the line wires are again attached, the trouble is either in the line or in the wiring or apparatus of one of the other telephone sets on the line. Examine the wiring and line carefully for a place where one wire crosses another or a place where two wires have been fastened under the same staple. If no trouble is found with the wiring, look for a place where the telephone line comes in contact with a tree or the ground, or where one wire touches another.

If, with the wires disconnected from terminals "Line 1" and "Line 2" (or "L1" and "L2") in the telephone set, the generator handle turns hard and the bell does not ring, it indicates that the trouble is in the set, and that the wiring of the set may have become damaged in unpacking or installing. The wiring should be in accordance with the diagram fastened to the inside of the door of the telephone set.

2. You cannot ring up anyone. Your generator handle turns easily. Your bell rings when you turn the generator handle.

Look for a loose connection at terminals "Line 1" and "Line 2" (or "L1" and "L2") of the telephone set, at the terminals of the protector, or where the inside wiring is connected to the outside wires. If the trouble is not located at these points, look for a broken wire or poor ground connection.

3. You cannot ring up anyone. Your generator handle turns easily. Your bell does not ring when you turn the generator handle.

Look for a loose connection or a broken wire in the telephone set. It may be that one of the wires to the

generator is disconnected or one of the line wires or one of the ringer wires may be loose.

4. You cannot ring other bells on the line very well. Your bell rings when you turn the generator handle.

Look for a loose connection at terminals "Line 1" and "Line 2" (or "L1" and "L2") of the telephone set, at the terminals of the protector, where the inside wiring is connected to the outside wires or at the ground connection. It is possible that the trouble may be due to a poor splice in the line wire or to contact between the line wire and trees.

5. Your bell does not ring but you are able to ring up other stations on the line.

Look for a broken wire or loose connection in the wires leading from the ringer. If the connections and wires are in good condition, see that the ringer is properly adjusted. (See "Ringer Adjustment," page 15.)

If the bell will not ring, the fine wire used for winding the ringer coils may be broken or burned out. If such is the case, new ringer coils will be required. Send the ringer to the nearest distributor listed in this bulletin for repairs.

6. You can hear others but others cannot hear you.

Look for a loose connection or a broken wire leading from the transmitter, or battery. Examine the wires connecting the dry cells. See if the connections to the induction coil are made in accordance with the diagram fastened to the inside of the door of the telephone set. If this examination does not disclose the trouble, tap the underside of the transmitter lightly with the hand. If this does not remedy the trouble, it may be due to ex-

hausted dry cells. This condition may be quickly determined by means of a Western Electric No. 35 battery gauge. When it is necessary to replace the dry cells, be sure that they are fresh and replace all the cells at one time. Never connect a new cell to old cells.

7. You cannot hear others but others can hear you.

Look for a loose connection or broken wire leading from the receiver, switchhook, or induction coil. Be sure that the ear cap of the receiver is screwed up tight, if not, it may be the cause of the trouble. If the ear cap is tight, the trouble may be in the diaphragm. Remove the ear cap from the receiver and clean the diaphragm. If the diaphragm is bent or otherwise injured, a new one will be required

If this does not remedy the trouble, remove the receiver cord from the terminals marked "REC" and, while holding the receiver to the ear, touch the two terminals of the receiver cord to the terminals of one of the dry cells. If a click is heard in the receiver whenever this connection to the dry cell is either made or broken, the receiver is in good condition. If no click is heard, the receiver or the receiver cord is probably damaged and should be replaced.

8. Neither you nor others can hear distinctly.

This is an indication of loose connections or poor joints either in the wiring of the telephone set or in the line.

ACCESSORIES AND REPLACEMENT PARTS

The following parts may be obtained from the nearest distributor listed in this bulletin. The individual apparatus in the No. 1317 type telephone sets, such as the generator, transmitter, ringer, condenser, receiver, etc., are marked with code numbers, but the code number of the telephone set, as well as the code number of the part, should, in all cases, be given in the order. When ordering parts not listed below, describe the part and give the code number of the set on which it is used.

<u>Name of Part</u>	<u>How to Order</u>
Battery	Blue Bell Battery
Battery Gauge	No. 35 Battery Gauge

TRANSMITTER PARTS

<u>Name of Part</u>	<u>How to Order</u>
Mouthpiece (For No. 323-BW Transmitter)	P-84570 Mouthpiece
Mouthpiece (For No. 349-BW and No. 359-BW Transmitters)	P-93553 Mouthpiece

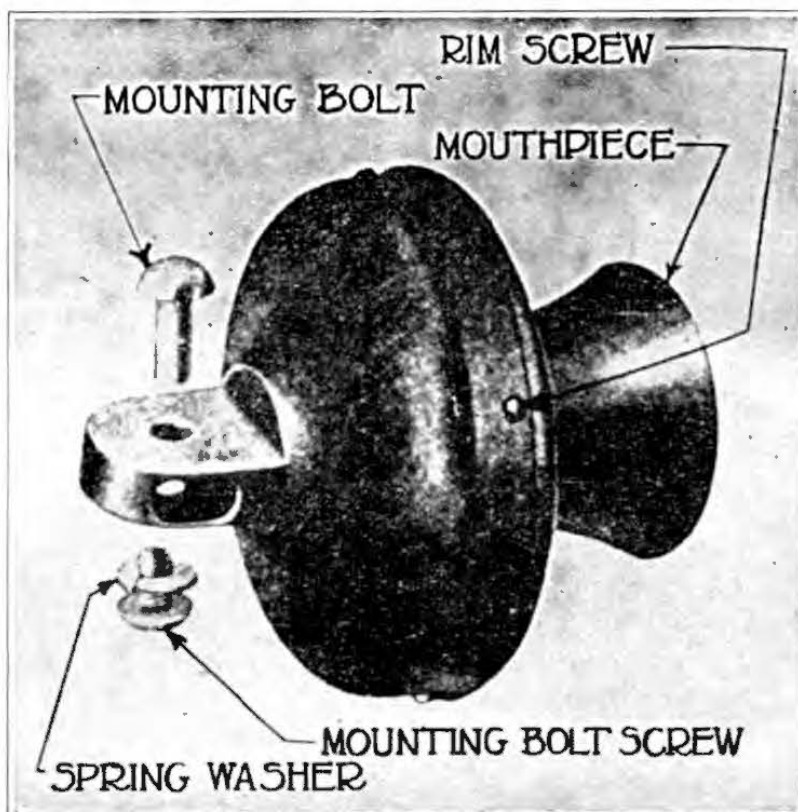

FIG. 16—TRANSMITTER PARTS

TRANSMITTER PARTS—(Cont'd)

Name of Part	How to Order
Rim Screw (See Fig. 16)	P-99649 Screw
Mounting Bolt (See Fig. 16)	P-92375 Bolt
Mounting Bolt Screw (See Fig. 16)	P-92378 Screw
Spring Washer (See Fig. 16)	P-92381 Washer
Transmitter Cord	T1A Cord

RECEIVER PARTS

Name of Part	Code No. of Receiver	How to Order
Diaphragm	143-AW	P-95114 Diaphragm
“	508-W	P-95114 “
“	186-W	P-95225 “
“	144-AW	P-95114 “
“	189-W	P-95225 “
Ear Cap	143-AW	P-93519 Ear Cap
“ “	508-W	P-99073 “ “
“ “	186-W	P-97614 “ “
“ “	144-AW	P-93520 “ “
“ “	189-W	P-145247 “ “
Case	143-AW	P-93518 Case
“	508-W	P-93518 “
“	144-AW	P-94533 “
Headband	186-W	No. 3-B Headband
“	189-W	No. 3-B “
Receiver Cord	143-AW	No. 521 Cord
“ “	508-W	No. 446 “
“ “	186-W	No. 546 “
“ “	144-AW	No. 521 “
“ “	189-W	No. 546 “

PROTECTOR PARTS

Parts for No. 58-AP Protector	How to Order
Fuse	No. 11-C Fuse
Protector Block (Carbon)	No. 26 Protector Block
Protector Block (Porcelain with Carbon Insert)	No. 27 Protector Block

PROTECTOR PARTS—(Cont'd)

Parts for No. 60-AP Protector	How to Order
Protector Block (Carbon)	No. 26 Protector Block
“ “ (Porcelain with Carbon Insert)	No. 27 “ “
Parts for No. 58-B Protector	How to Order
Fuse	No. 11-C Fuse
Protector Block (With Dowel-pins)	No. 19 Protector Block
“ “	No. 20 “ “
Protector Mica	No. 10 Protector Mica

GENERATOR PARTS

Name of Part	Code No. of Generator	How to Order
Crank	22-A	P-158949 Crank
“	22-D	“ “
“	22-E	“ “
“	22-BA	“ “
“	22-BE	“ “
“	48-A	P-158950 Crank
“	48-B	“ “
“	48-R	“ “
“	50-F	P-158949 Crank
“	D-13730	P-158950 “

RINGER PARTS

Name of Part	Code No. of Ringer	How to Order
Armature Adjusting Nuts	52-A	P-152 Nuts
Biassing Spring	52-A	P-43763 Spring
“ “	54-B	P-108458 Spring
“ “	55-A	P-43763 Spring
Locking Screw (For Ringer Adjustment)	(All Code Nos.)	P-112962 Screw

SWITCHHOOK PARTS

Name of Part	Code No. of Switchhook	How to Order
Lever (Including Roller)	D-19513	P-123514 Lever
“ “ “	143-W	“ “
“ “ “	143-Y	“ “
“ “ “	143-AA	“ “
“ “ “	143-AC	P-139256 Lever
“ “ “	143-AE	“ “
Fulcrum Pin	(All Code Nos.)	P-158139 Pin

GONGS

No. 26-A Gong for use on the Nos. 1317-N, P, R, S, W, AH, AK, AL, AW, BA, BB and BL Telephone Sets.

No. 29-A Gong for use on the Nos. 1317-AU, BS, CA, CG, CH, CJ, CN, CP, CR and CS Telephone Sets.

Note: The code number covers one gong. It does not include the gong screw.

<u>Name of Part</u>	<u>How to Order</u>
Gong Screw	P-13695 Screw

INSTRUCTION BULLETIN NO. 301

Printed in U.S.A

DISTRIBUTOR IN THE UNITED STATES

Graybar

ELECTRIC COMPANY

Distributors of WESTERN ELECTRIC Products

Akron
Albany
Asheville
Atlanta
Baltimore
Beaumont
Birmingham
Boston
Brooklyn
Buffalo
Charlotte
Chicago
Cincinnati
Cleveland

Columbus
Dallas
Davenport
Dayton
Denver
Detroit
Duluth
Flint
Fort Wayne
Fort Worth
Grand Rapids
Harrisburg
Hartford
Houston

Indianapolis
Jacksonville
Kansas City
Knoxville
Los Angeles
Memphis
Miami
Milwaukee
Minneapolis
Nashville
Newark
New Haven
New Orleans
New York

Norfolk
Oakland
Oklahoma City
Omaha
Philadelphia
Pittsburgh
Portland
Providence
Reading
Richmond
Roanoke
Rochester
St. Louis
St. Paul

Salt Lake City
San Antonio
San Francisco
Savannah
Seattle
Spokane
Syracuse
Tacoma
Tampa
Toledo
Trenton
Wichita
Worcester
Youngstown

A NATIONAL ELECTRICAL SERVICE

DISTRIBUTOR FOR CANADA AND NEWFOUNDLAND

NORTHERN ELECTRIC COMPANY, LIMITED

Plant and General Offices:
121 Shearer Street, Montreal, P. Q.

Branch Houses

Montreal
Halifax
Quebec

Ottawa
Toronto
London
Hamilton

Windsor
New Liskeard
Winnipeg

Regina
Calgary
Vancouver

FOREIGN DISTRIBUTORS

International Standard Electric Corporation

67 Broad Street

New York, U.S.A.

Associated Companies

ARGENTINA—

Cia Standard Electric Argentina,
Casilla de Correo 49, (Street Address,
Paseo Colon 185), Buenos Aires.

AUSTRALIA—

Standard Telephones and Cables
(Australasia) Ltd., 82/86 Myrtle
Street, Chippendale. (P.O. Box 21),
Sydney, N.S.W.

AUSTRIA—

United Telephone and Telegraph
Works, Ltd. Dredner Strasse
No. 75, Vienna, XX/2.

BELGIUM—

Bell Telephone Manufacturing Co.,
18 Rue Boudewynus, Antwerp.

BRAZIL—

International Standard Electric Corp.,
Caixa Postal 219, (Street Address,
Rua dos Ourives 91-1), Rio de Janeiro.

CHINA—

China Electric Co., Ltd., 3 Hsi
Tang Tse Hutung, East City,
Peking.

China Electric Co., Ltd., Kinchong
Bank Building, 22 Kiang Road,
Shanghai.

CZECHOSLOVAKIA—

Standard Electric Doms a Spolecnost
Vrsovice 664, Samova, Prague.

EGYPT—

Standard Telephones and Cables,
Ltd., 26, Sharia El Manakh, (P.O.
Box 2034), Cairo.

ESTONIA—

Techn Buroo (Standard Electric)
Ins. A. E. Reinke, 11 Vene tanav,
Tallinn.

FRANCE—

Le Materiel Telephonique, 46 Avenue
de Breteuil, Paris.

GREAT BRITAIN

Standard Telephones and Cables,
Ltd., Connaught House, Aldwych,
London, W.C. 2.

HOLLAND—

Bell Telephone Manufacturing Co.,
Scheldestraat 160-162, The Hague.

HUNGARY—

Standard Villamossagi R. T. Ujpest
n. Budapest.

INDIA—

Standard Telephones and Cables, Ltd.,
C-2 Clive Building, (P.O. Box 413),
Calcutta.

ITALY—

Standard Elettrica Italiana, Via
Vittoria Colonna No. 9, Milan 25.

JAPAN—

Nippon Electric Co., Ltd., 2 Mita
Shikokumachi, Shiba-Ku, Tokyo.

NEW ZEALAND—

Standard Telephones & Cables
(Australasia) Ltd. 24-26 Ballance
Street, P. O. Box 638, Wellington.

NORWAY—

Standard Electric Aktieselskap,
Drammensveien 20, Oslo.

POLAND—

Standard Electric Co., W. Polsee,
Sp. z.o.o., Warsaw, Matejki 7.

SOUTH AFRICA—

Standard Telephones and Cables, Ltd.,
Exploration Buildings, Commissioner
and Fox Streets, (P.O. Box 1571),
Johannesburg.

SPAIN—

Standard Electrica S/A. Calle de
Ramirez de Prado 3 y 5. (Post
Office Box 7040), Madrid.

STRAITS SETTLEMENTS—

Standard Telephones and Cables, Ltd.,
57 Robinson Road, (P.O. Box 553),
Singapore.

SWITZERLAND—

Bell Telephone Manufacturing Co.,
10 Bubenberplatz, Berne.