

**STROMBERG-CARLSON**

**GENERAL CATALOG**

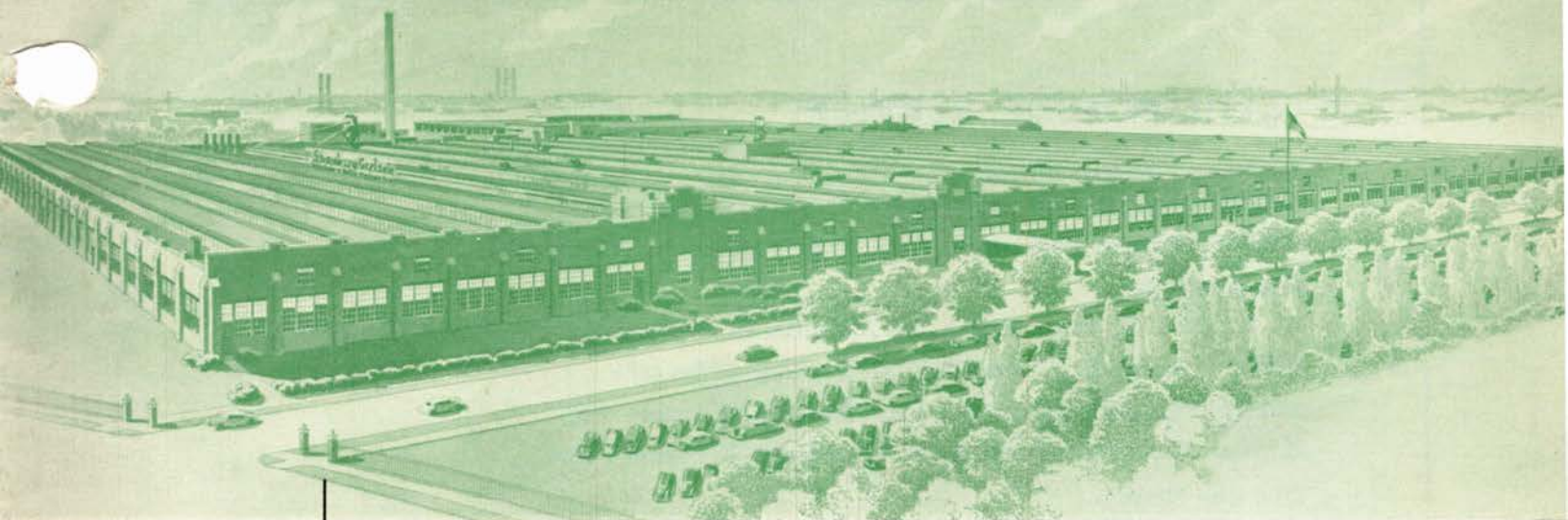

# STROMBERG-CARLSON

---

TELEPHONES

---

SWITCHBOARDS

---

ACCESSORIES

---

CODED PARTS

---

CONSTRUCTION MATERIALS

STROMBERG-CARLSON COMPANY

100 CARLSON ROAD • ROCHESTER 3, N. Y. • TEL. CULVER 0260

# NATION-WIDE SERVICE

## **Factory and General Offices:**

**STROMBERG-CARLSON COMPANY**

100 Carlson Road, Rochester 3, N. Y., U. S. A.—Telephone Culver 0260

## **Branch Offices:**

411-412 Connally Bldg., Whitehall & Alabama Sts., Atlanta, Ga.—Telephone Walnut 4356

564-70 W. Adams St., Chicago 6, Ill.—Telephone STAtE 4234

2017 Grand Ave., Kansas City 8, Mo.—Telephone HArrison 6618

325 Ninth St., San Francisco 3, Cal.—Telephone UNDerhill 1-5388

## **Canadian Plant:**

**STROMBERG-CARLSON COMPANY, LTD.**

211-219 Geary Ave., Toronto 4, Canada—Telephone MELrose 2453

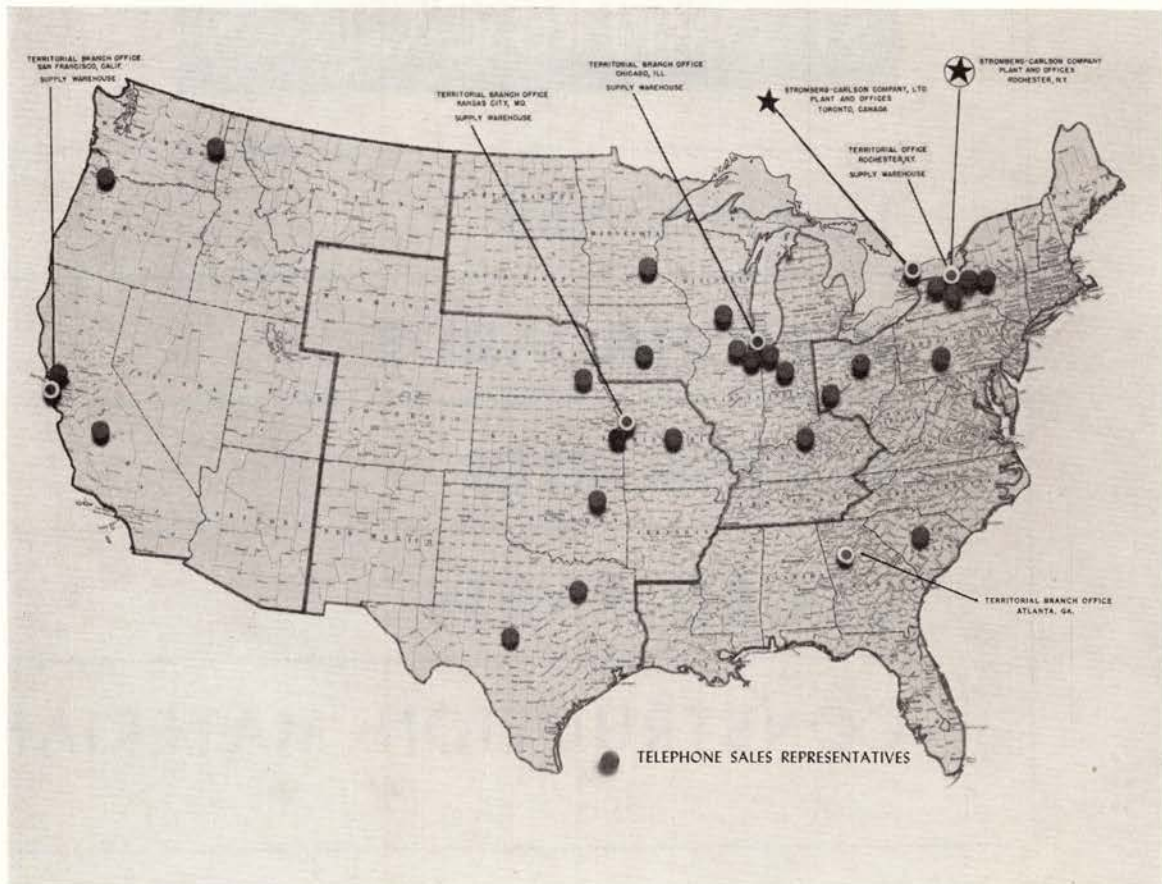

# Foreword

OLD FRIENDS will recognize the main entrance to the Stromberg-Carlson plant—a doorway dedicated to service for the industry. This catalogue, like the door, is an invitation to look inside at the products which have made the name Stromberg-Carlson stand for the finest in telephone equipment.

This new catalogue is different in appearance and arrangement from the old, but it retains the same, or similar, factual information on Telephones, Switchboards, Accessories, Coded Parts, and Construction Materials, that made the former catalogue such a helpful reference book. Changes have been made with the expectation that it will be easier to use, and consequently of more value to you. It is your door to Stromberg-Carlson's advanced engineering and time proven, dependable, economical telephone equipment.

Users of this book will find information on all products which meet the requirements of the industry at large. A selection from these standard products will insure more rapid delivery and tangible economies for the purchaser. The accompanying map shows the warehouses in strategic locations for carrying on nation-wide service. Here are kept supplies of telephones and maintenance parts of all types; also selected construction materials

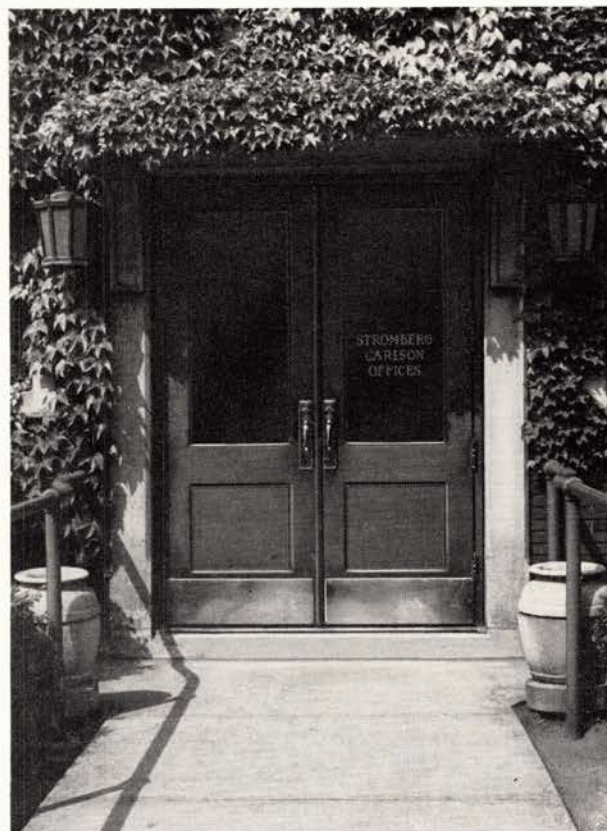

which conform to the high standard of Stromberg-Carlson's own products.

The book has two principal divisions. In the first are those items manufactured by Stromberg-Carlson and such others as are necessary for the modern plant. These are grouped into convenient sections. The second division covers construction materials and supplies, also divided into sections, thus making it an easy matter to locate the desired items. Colored thumb-index tabs on the sectional sheets, and a complete alphabetical cross index at the center of the book, give further assistance, and will enable you to locate in a minimum of time the technical or ordering information desired. Price information has been conveniently placed on separate sheets interleaved through the catalogue so that complete data is available quickly and easily.

# For your Information



**OUR WARRANTY** — For more than half a century Stromberg-Carlson's high quality production standards have been well known to the telephone industry and an enviable record for excellence in manufacture has earned for the Company many friends and satisfied customers. Because of this record, all material properly installed and operated is fully guaranteed against defects in material and workmanship for a period of one year from the date of shipment.

**WHEN ORDERING** — In order to assure prompt handling and shipment of your order please include the name or description of each article and its Stock Number and Code Number. When requesting information please use a separate sheet from the order blanks.

**SHIPPING INFORMATION** — Shipment can be expedited and better service obtained if complete shipping information is given, such as rail freight, express, truck or parcel post. If by rail freight or truck, give the routing, otherwise we shall use our judgment to assure you of the best service.

Unless otherwise agreed upon, all goods are sold f.o.b. Rochester, N. Y., or f.o.b. Branch Offices, and transportation charges will therefore be collected by the carriers upon arrival of the goods at destination.

**ALL AGREEMENTS** — Are made contingent upon strikes, fires, accidents or causes beyond our control.

**TERMS** — Are net 10 days E. O. M. (End of Month) billing.

**NEW ACCOUNTS** — Are welcomed on a credit basis. When you are not rated by commercial credit agencies shipment can be handled more quickly if references and credit information are sent with the order. Special references or information will be immediately acted upon, and the result held in strict confidence for our sole use.

In order to avoid delay incidental to checking references you may prefer to have an initial order shipped C.O.D. by express or parcel post (insured if so instructed), or by freight subject to sight draft through a local bank against bill of lading. C.O.D. or sight draft orders receive the same prompt handling as other orders.

**REMITTANCES** — May be made by bank draft, postoffice or express money orders. Cash should be sent only by registered mail. Unless accompanied by orders all remittances should be addressed to our General Offices at Rochester 3, New York.

**CLAIMS AGAINST TRANSPORTATION COMPANIES** — Should be made immediately by you upon receipt of the shipment when evidence of the breakage or shortage is discovered. We will gladly assist you in presenting these claims.

**RETURN SHIPMENTS** — In the event that it is necessary to return material to the factory please write us for shipping instructions. This will enable us to make proper adjustment without delay, and to provide for the most efficient handling of the returned material.

**SUBSTITUTIONS** — In some instances it may be necessary to depart from the specifications covering materials listed in this catalog. Substitutions will be made only when regular materials are not obtainable. They will be chosen carefully in order to assure you of the dependability and excellent service you expect of Stromberg-Carlson equipment.

**STROMBERG-CARLSON**

# Magneto Telephones



The magneto telephone comes into its own with these attractive Stromberg-Carlson units. The new Alnico generator provides greater compactness and power than previous types, while the single interchangeable base permits quick economical conversion for common battery or dial use.

CONTENTS  
SECTION A

**MAGNETO TELEPHONES**

	Page
Desk Type Handset Telephones . . . . .	4α
Wall Type Handset Telephones . . . . .	6α
Desk Set Boxes . . . . .	8α
Two-Piece Telephone Sets . . . . .	8α
Ironclad Weatherproof Telephones . . . . .	10α
Former Telephone Models . . . . .	12α

The purpose of this section is to present the complete line of Stromberg-Carlson telephones and parts, along with helpful data for selecting the right telephone, or part, for the job. Telephone sets are in the custody of, and used by, those outside the control of the operating telephone company. For this reason, simplicity of design, ruggedness of construction, dependability of operation, safety, and flexibility are inherent requirements. All these features, and attractiveness too, are built into Stromberg-Carlson instruments.

## NEW STROMBERG-CARLSON TELEPHONES

# meet four fundamental requirements

### SIMPLICITY

#### Few Essential Parts

##### BASE

Combined Coil and Capacitor Unit  
Ringer  
Minimum Wiring

##### HOUSING

Dial  
Plunger Switch

##### HANDSET

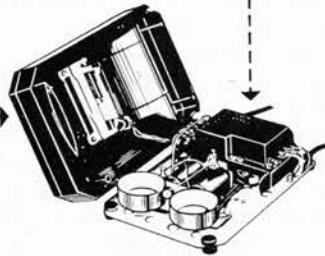

### DEPENDABILITY

Hydrolene-sealed unit of the capacitor and induction coil eliminates damage from water or condensed moisture.



All wiring including the handset cord is waterproof.



The only tool needed to make all connections is a screwdriver.

The handset will operate in any position, with high fidelity and clearness on long or short lines.

### DURABILITY

#### Proven Ruggedness

Zinc die-cast housing withstands severe shock; is practically impossible to damage by careless handling.

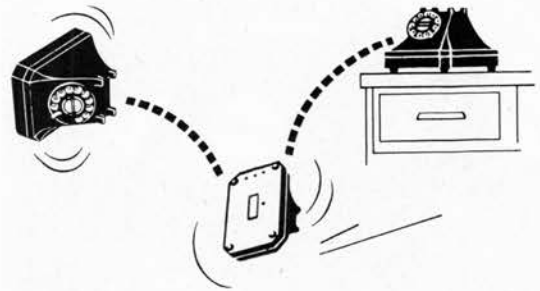

The tough phenolic compound molded handset resists mechanical blows so well that it is almost impossible to render inoperative.

### FLEXIBILITY

The variety of ways in which it can be furnished, and the ease with which it can be converted makes the Stromberg-Carlson Telephone an economical buy for operating companies.

It is supplied as a self-contained unit with ringer, or less ringer for use with separate bell box. It can be supplied for common battery Manual or Dial Service, and is readily converted from one to the other.

The Telephone with separate bell box can be used on either common battery or magneto service.

In the base of the instrument are the necessary provisions for mounting, Vincent Rare Gas Relays or W E Co.'s No. 333 A Tube, if required for grounding.

## MAGNETO TELEPHONES

In appearance, efficiency, adaptability and long life, the new Stromberg-Carlson Magneto Telephones offer everything you would expect from one of the industry's oldest, most experienced companies.

This new Magneto series includes a self-contained desk type handset telephone (No. 1248-W), a self-contained wall type handset telephone (No. 1258-W), and a Magneto desk set box (No. 1268-W).

The base assemblies of all three instruments are interchangeable for service economy. All are exact counter-parts of the new Stromberg-Carlson common battery telephones, and may be easily converted at any time by the operating company. Any American-made dial may be installed when this type of service is required.

### DESK TYPE HANDSET TELEPHONES



No. 1248-W Handset Desk Telephone

**THE NO. 1248-W** is a thoroughly modern self-contained desk type magneto telephone in a streamlined die-cast zinc housing which includes the handset cradle. Below the cradle, in the rear of the housing, there is a recess which forms a convenient handle that can be used when the telephone is moved. The baked enamel finish has a rich, semi-glossy surface which is durable and wear-resisting. The four rubber feet that are forced into slotted openings at each corner of the base plate firmly grip any surface on which the telephone is placed. These feet are also used to elevate the base to a point where the ringer signal is plainly heard.

The base plate of cadmium finished flat steel is attached to the housing by screws which may be easily removed for inspection and testing of all component parts. These parts are so designed and mounted on the base that it is an easy matter to change from magneto to common battery operation with either manual or dial service.

**THE NO 200595 INDUCTION COIL AND CAPACITOR ASSEMBLY** consists of a sealed plastic housing in which the coil and capacitor are embedded in hydrolene, which is a dense, tar-like compound. This design effectively protects the apparatus from mechanical injury as well as excessive humidity, and is therefore particularly desirable in hot, damp climates. At either end of the housing there is a row of screw type terminals which are plainly marked to show the proper connections. These include terminals for the line and handset cords as well

as the wiring of the component parts that are mounted on the metal base of the telephone. The same induction coil and capacitor assembly are used in both the No. 1248 and No. 1243 type self-contained handset telephones so that this unit does not have to be replaced in changing from magneto to common battery service. In the No. 1248 telephone the  $\frac{1}{2}$ mf section of the capacitor is wired in the receiver circuit for sure-ringing operation, but this feature is not fully effective unless other telephones on the line are similarly equipped. This condenser makes it possible to ring past telephones on party lines when the receiver is not on the hook. There is another  $\frac{1}{2}$ mf capacitor section in the coil and capacitor unit that can be connected to the ringer circuit by making two simple wiring changes.

**WIRING OF THE TELEPHONE** consists of vinylite insulated conductors with a separate cable for the hookswitch assembly. The line and handset cords are waterproof, with conductors of vinylite-insulated flat ribbon tinsel and an external braid of black mercerized cotton. This type of insulation is used in permanent colors that will not fade and it successfully withstands the bad effects of damp and humid climates.

**THE NO. 65 RINGER** is of the same general design as the small type ringers in all self-contained telephones and desk set boxes in our current line. The two metal gongs are of different thickness which produces a two-toned effect, resulting in a clear, distinct, signal that compels attention without being annoying.

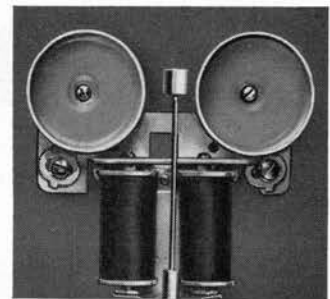

No. 65 Ringer

The Ringer is specially designed for Magneto service with standard resistances of 3100 and 4850 ohms. Because the impedance of the No. 65 and the older type ringers is matched, resistances of 1600 ohms and 3100 ohms may be satisfactorily used on the same line. This is also true of 2500 ohms and 4850 ohm ringers.

The complete ringer movement, including gongs, is set in a rubber mounting which serves as a cushion to eliminate the harsh vibrations caused by a metal-to-metal mounting. The way in which the ringer is mounted provides a full view of the code number and frequency through a clear plastic window in the base plate.

## DESK TYPE MAGNETO TELEPHONES (Cont.)

**THE HOOKSWITCH ASSEMBLY** provides a reliable method of controlling the telephone circuit. The plastic plunger rods at either end of the cradle engage a hinged lever which operates an arm that pushes the springs into the proper position, regardless of the position of the handset in the cradle. As a further means of assuring positive action, each spring is equipped with twin contacts.

**THE NO. 24-W HANDSET** is a new type in which the similar contour of transmitter and receiver produces an evenly balanced unit. The handle, as well as the earcap and mouthpiece, are made of tough molded material that has a maximum resistance to breakage. Spring contacts, attached to inserts, are molded into the cavities for the transmitter and receiver, each of which is firmly positioned when the mouthpiece and earcap are tightly clamped in place. The No. 24-W handset is equipped with a four conductor, 4' 6" waterproof cord with a black braid of mercerized cotton; otherwise it has the same parts as the No. 23-W handset used with the Common Battery Telephones.

**THE NO. 200486 TRANSMITTER** is a capsule type which will reproduce the voice naturally in any position. It is the result of knowledge gained in the design of loud speakers used in radios. The diaphragm is made in the shape of a cone which causes its center to move as a rigid unit with a piston-like motion. This movement is increased by the annular corrugations near the outer edge of the diaphragm which give it maximum flexibility.

This transmitter is placed in the correct position simply by dropping the capsule into the cavity in the handle. The mouthpiece is then clamped down tightly which makes solid spring-pressure contacts that will not work loose.

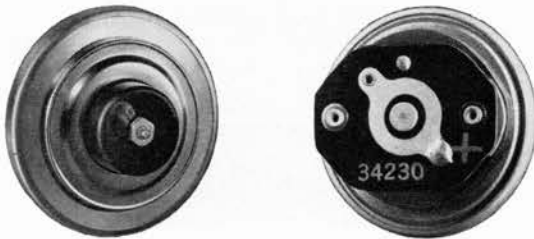

No. 200486 Transmitter No. 34230 Receiver

**THE 34230 CAPSULE RECEIVER** unit provides a smoother, less resonant response frequency characteristic than any previous receiver. Improved articulation is secured by placing the resonance peak at 2000 cycles per second, while at the same time introducing the proper degree of controlled damping. Temperature stability is maintained under all service conditions. Extreme ruggedness has been obtained through the careful choice and application of engineering materials. Freedom from electrical deterioration under the most severe humidity conditions results from the use of heavy enameled wire coils in conjunction with special insulating materials.

**THE NO. 64 ALNICO GENERATOR**, reduced in size for the new streamlined telephones, is as powerful as the older, more bulky types. This is due to the use of Alnico magnets which were furnished with equipment built for the Signal Corps and successfully used during the entire war period under every possible unfavorable condition.

**THE NO 16-A TERMINAL BLOCK** is supplied with the No. 1248 and all other types of self-contained desk type telephones. This block consists of a base and cover of black plastic with a finish that wears indefinitely in actual service. Dimensions: 2½" long, 2" wide and 27/32" high. The base has an anchor post which takes one screw by means of which the cover is attached. On this block there are also four terminal plates, each with two connecting screws. Station wires coming from the baseboard or wall are brought through a 5/16" hole in the base of the block. Two notches in the cover — one on either side — are also provided for the line cord and station wires. This terminal block is furnished with the line cord which eliminates the use of a separate battery cord.

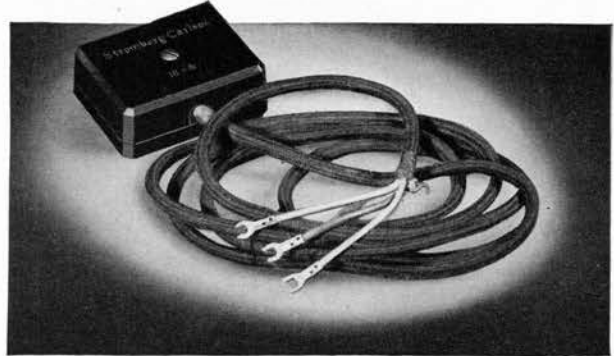

No. 16-A Terminal Block,  
for either 3 or 4 Conductor Line Cord

**NON-INTERFERING PUSH BUTTON** will be supplied on any magneto telephone when so ordered. It is used for signalling central over one side of a metallic circuit and ground, without ringing the bells of the other telephones on the line.

### Magneto Telephones With Straight Line Biased Ringer

To answer the request for a type of magneto service which would approximate the method of signalling in common battery operation, Stromberg-Carlson now offers the new Magneto Telephones Nos. 1248-A, 1248-B, 1248-S. Four-party fully selective ringing is possible with the 1248-A, eight-party semi-selective ringing with the 1248-B, eight ringers for semi-selective ringing with extensions if desired with the 1248-S. This selective signalling is accomplished by shifting the connecting wires within the telephone.

These telephones can be used wherever the standard straight line magneto telephone is used, except that it is not advisable to use the biased ringing type on straight bridged lines. This is because the biased ringer does not respond as well to party ringing by the subscriber, although perfectly satisfactory when rung from the central office. For best results do not mix the biased ringing type with the standard type of telephone on the same line.

Ordering information for No. 1248 Desk Telephones, both of the standard straight line type and the straight line biased (plus-minus) type are shown on the following page along with the No. 1258 Wall Telephone.

STROMBERG-CARLSON

## MAGNETO TELEPHONES (Con't.)

**NO. 1258-W WALL TYPE HANDSET**, like the common battery wall type No. 1250, is a streamlined telephone having a plastic housing with a semi-glossy finish that will retain its luster indefinitely.

The removable metal sub-base that houses the generator and all the component parts is the same as in the No. 1248-W desk type; including base plate, coil and capacitor unit, generator, ringer and hookswitch. The handset piece which is also the same, rests in a cradle that is part of the molded case. Vinylite wiring is used for the component parts, with a separate cable for the hookswitch.



No. 1258-W Wall Telephone

**EASY TO CONVERT.** The design of this new wall set, as in the case of the No. 1248-W desk type, makes it easy and economical to change from magneto to common battery service with either manual or dial operation.

In the event that these magneto telephones are converted to common battery use, it is possible to obtain all the features of the 1240, 1250, and 1260 series, including the Vincent Rare Gas Relay and Western Electric Company's No. 333 A Tube.

**NON-INTERFERING PUSH BUTTON.** This is an additional feature, for which wiring only is provided. The No. 49299 push button is mounted in the center of a plastic plate which covers the dial opening. This push button can be installed in telephones shipped from the factory or ordered separately as Package assembly No. 201358.

**SURE-RING CONDENSER** standard equipment includes a ½ mf capacitor in the receiver circuit which makes it possible to ring past telephones on party lines when the receiver is not on the hook. There is also available another ½mf capacitor in the induction coil—capacitor unit that can be connected to the ringer circuit by making two simple wiring changes.

### DIMENSIONS:

1248-W 7¼" high with handset in cradle, 5¾" x 8½" base  
1258-W 8¾" high with handset in cradle, 5¾" x 8½" base

### WEIGHT:

1248-W Net 10 lbs. Packed for domestic shipment 13 lbs.  
1258-W Net 8 lbs. Packed for domestic shipment 11 lbs.

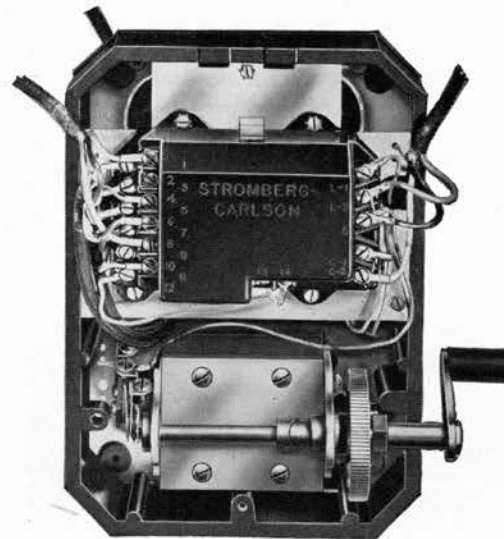

Interchangeable Magneto Base  
Common to all telephones  
Easily Converted to Common Battery

## STOCK AND CODE NUMBERS OF TELEPHONES

No. 1248-W Handset Desk Type					No. 1258-W Handset Wall Type				
Telephone		Ringer			Telephone		Ringer		
Stock No.	Code	Stock No.	Code	Resistance	Stock No.	Code	Stock No.	Code	Resistance
Straight Line									
201804	(1248-WI)	201754	(65-C)	3100 Ohms	201808	(1258-WI)	201754	(65-C)	3100 Ohms
201805	(1248-WL)	201755	(65-F)	4850 Ohms	201809	(1258-WL)	201755	(65-F)	4850 Ohms
*201806	(1248-WIP)	201754	(65-C)	3100 Ohms	*201810	(1258-WIP)	201754	(65-C)	3100 Ohms
*201807	(1248-WLP)	201755	(65-F)	4850 Ohms	*201811	(1258-WLP)	201755	(65-F)	4850 Ohms
Straight Line Biased									
203071	(1248-WA)	801911	(61-A)	1800 Ohms					
203035	(1248-WB)	202880	(65-B)	3100 Ohms					
203069	(1248-WS)	801912	(61-S)	4850 Ohms					

\* The letter "P" indicates No. 49299 Push Button mounted on Dial Blank. All No. 1248-W Telephones are equipped with Sure-Ring Condensers (½ MF) in the receiver circuit.

MAGNETO TELEPHONES (Con't.)

Parts of No. 1248-W (Desk) and No. 1258-W (Wall) Types

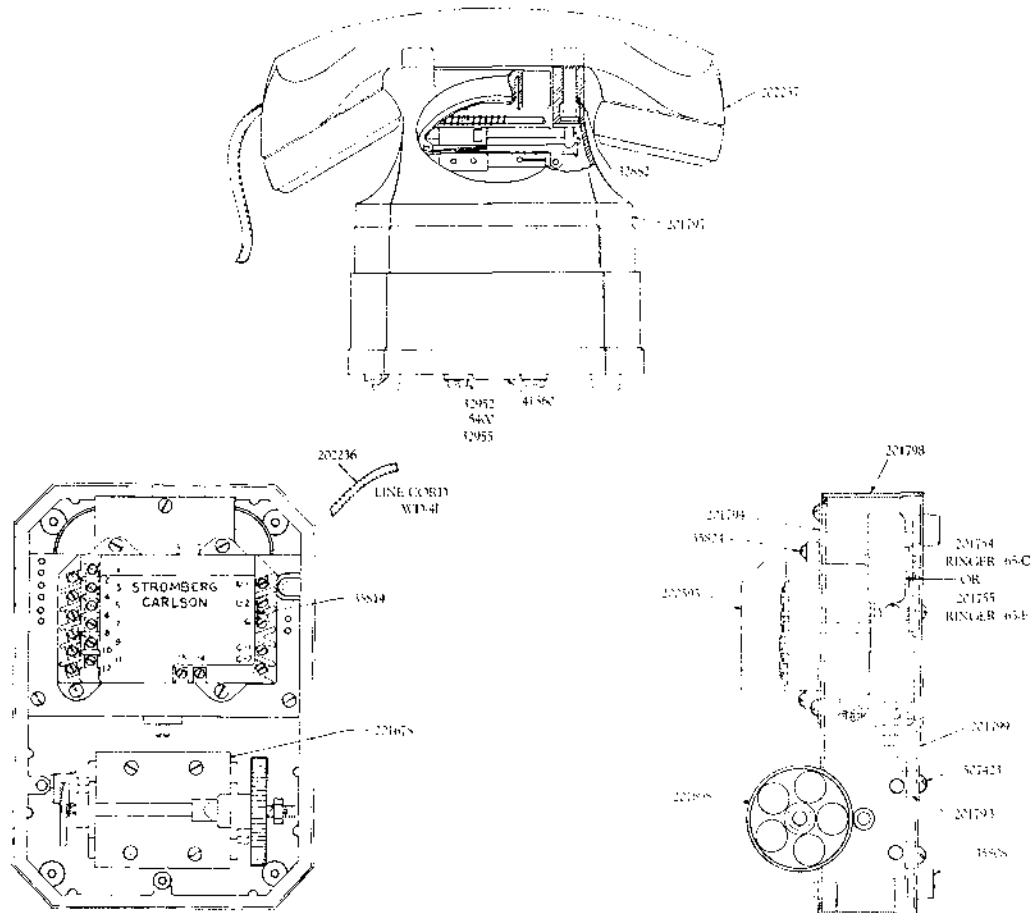

Parts of No. 1248 and 1258 Magneto Telephones

Telephone Parts

- 201797 Housing (No. 1248-W only)
- 201796 Housing (No. 1258-W only)
- 201798 Sub-Base (Die-cast housing adapter)
- 508753 Screws (2) Sub-Base
- 201799 Base Plate (Flat metal)
- 35808 Feet (4)
- 32889 Rod (Handle)
- 32890 Rod (Lever)
- 201818 Retaining Screw (Rod)
- 35804 Bracket (Spring Combination)
- 33234 Screws (Bracket)
- 42158 Complete Spring Comb. (Hookswitch)
- 35860 Cable (Hookswitch)

Handset Parts

- 202237 (No. 24-W) Handset with black cord
- 202235 Cord (WC-4J) 4' 6"
- 32862 Molded Handle
- 200486 Transmitter
- 34230 Receiver
- 32863 Mouthpiece (Transmitter)
- 32864 Earcap (Receiver)
- 200595 Ind. Coil and Capacitor Unit in Plastic case
- 201794 Plate (Plastic case mounting)
- 35824 Screws (4) Case to Plate
- 41566 Connector (1) Term Block
- 35814 Connector (2) Term Block

Generator Parts

- 201678 (No. 64) Generator, Alnico
  - 201792 Generator Crank assembled
  - 507423 Screws (4) Generator Mtg.
  - 201793 Spacers (4) Generator Mtg.
- For other parts see Generator in Coded Parts Section

Ringer Parts

- 201754 (No. 65-C) Ringer (3100 Ohms)
  - 201755 (No. 65-F) Ringer (4850 Ohms)
  - 201751 Coil (2) (No. 65-C) Ringer
  - 34950 Coil (2) (No. 65-F) Ringer
  - 28569 Gong } pair 1 3/4"
  - 28570 Gong }
  - 28433 Screws (2) Gongs
  - 526281 Washers (2) Gongs
- For other parts see Ringers in Coded Parts Section

Waterproof Cord (Black)

- 202236 Line Cord (WD-4J) 6' (No. 1248-W only)

Terminal Block

- 201339 (No. 16-A) For Line Cord (No. 1248-W only)
- When push button is not furnished
- 35709 Dial Blank covers the dial opening — with
- 23766 Cap
- 25404 Protector
- 28479 Card

## MAGNETO DESK SET BOX AND TWO-PIECE TELEPHONES

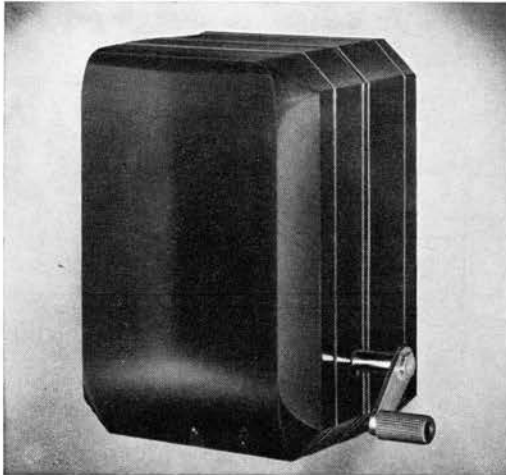

No. 1268-W Desk Set Box

The No. 1268-W Desk Set Box is a companion set of the No. 1248-W and 1258-W Handset Telephones, in a streamlined housing of black plastic with a durable, semi-gloss finish. It may be used with the No. 1244 Desk Type or No. 1234-M Suspended Handset Telephone to make an attractive and serviceable two-piece set. This new desk set box replaces the No. 1180 type.

The base plates of the No. 1268 Desk Set Box and the No. 1248 and No. 1258 Telephones are interchangeable and the same ringer, generator, and sealed coil-capacitor unit are used, together with identical parts for mounting this apparatus.

All No. 1268-W Desk Set Boxes are equipped, in the receiver circuit, with a ½ MF. capacitor which is embedded in the same sealed casing as the induction coil. This "Sure-Ring" feature makes it possible to ring past other telephones whose receiver has been removed.

### Optional Feature

No. 49299 Push Button is not furnished unless the letter "P" is added to the code number and its use is confined to full metallic (two-wire) lines.

When the button is depressed the central office switchboard is signalled by ringing over one side of the line and ground without disturbing the bells of other telephones on the line.

### Parts of No. 1268-W Desk Set Box

Stock No.	Description
201795	Plastic Housing
41710	Retaining Screw (Front)
525033	Hex, Nut (Retaining Screw)
201798	Sub-Base (Die-Cast Housing Adapter)
201799	Base Plate (Flat Metal)
41563	Screws (2) Housing to base
41560	Cover (Window) Base Plate
41685	Bracket (Base Plate)
35808	Feet (4) Base Plate
200595	Ind. Coil and Capacitor unit in plastic case
201678	Generator (See Generator in Coded Parts Section)
201754 (65-C)	Ringer (3100 Ohms)
201755 (65-F)	Ringer (4850 Ohms) (see Ringer in Coded Parts Section)

### STOCK and CODE NUMBERS

Desk Set Box		Ringer		Resist. Ohms
Stock No.	Code	Stock No.	Code	
201812	(1268-WI)	201754	(65-C)	3100
201813	(1268-WL)	201755	(65-F)	4850
*201814	(1268-WIP)	201754	(65-C)	3100
*201815	(1268-WLP)	201755	(65-F)	4850

\* Desk Set Boxes with suffix letter "P" are equipped with No. 49299 Non-Interfering Push Button.

Handset Telephone		Used With
Stock No.	Code	Desk Set Box
201377	(1244-W)	No. 1268
201650	(1244-B)	No. 327

## TELEPHONES FOR TWO-PIECE SETS



No. 1244 Desk Telephone

THE NO. 1244-W DESK TYPE Handset Telephone is the companion piece to the No. 1268 Desk Set Box shown above. This telephone is exactly the same externally as the No. 1243 self-contained Common Battery telephone, and can be used without change if Magneto service is changed to Common Battery; or the No. 1244-W can be converted to a No. 1243 by the addition of the ringer and induction coil-capacitor unit in the base.

The die-cast zinc housing has a long-wearing finish of black enamel. The removable base has four rubber feet which are designed to grip any surface. The No. 23-W Handset is an evenly balanced unit with capsule type transmitter and receiver for efficient transmission and operating economy.

THE NO. 1244-B TELEPHONE is the same as No. 1244-W except that it has an induction coil. It may, therefore, be used with desk set boxes which do not have induction coils, such as our old No. 327, or similar boxes of other makes.

TWO PIECE TELEPHONE SETS (Con't.)

Parts of No. 1244-W and 1244-B Telephones

Stock No.	Description
32883	Housing
35809	Base Plate
41563	Screws (2) Housing to Base
35808	Feet (4)
37001	Instrument Cable
<b>Hookswitch</b>	
42158	Hookswitch Spring Assembly (Complete)
32871	Lever (Plunger Switch)
35710	Plungers (2) Switch
32890	Rod (Lever)
35804	Bracket (Spring Combination)
33234	Screws (3) Bracket
32889	Rod (Handle)
<b>Induction Coil</b>	
25677 (45-B)	Induction Coil Assembly (1244-B)
There is no induction coil in No. 1244-W Telephone.	
<b>Handsets</b>	
803486 (23-W)	Handset with Cord (1244-W, 1244-B)
803552 (WC-3-J, 4' 6")	Cord 23-W Handset
<b>Line Cords</b>	
201374 WD-4-G, 6' 6"	(1244-W)
803490 WD-3-J, 6' 0"	(1244-B)



No. 1234-M Mounted on Side of Desk

NO. 1234-M SUSPENDED TELEPHONE

THE NO. 1234-M SUSPENDED TYPE Handset Telephone is the other companion piece to the No. 1268 Desk Set Box when a telephone of the hang-up type is desired. The handset (No. 20A) is of the new balanced-contour capsule type, and is easily gripped in its suspended position on the hook. The inconspicuous metal hook-switch box is finished in black to match.

A single screw unlocks the casing of the hook-switch box so that inspection and adjustments can be made easily when necessary. The mounting bracket is adjustable, allowing a choice of positions.

Many users have found this type of telephone to be a convenient space-saver, as it will mount on a wall, on the side of a desk, or in the knee-hole space.

The 1234 Telephone may be converted to common battery use without change; at this time a dial may be added if this type of operation is needed.

Parts of No. 1234-M Telephone

Stock No.	Description
34517	Casing Assembly
34518	Bracket (Casing)
505355	Screws (4) Bracket
526044	Washers (4) Bracket Screws
19136	Hookswitch Spring Assembly
503685	Screws (2)
24093	Hook (Handset)
<b>Handset</b>	
42906 (20-A)	Handset with cord
800617 (MC-3-F, 4' 9")	Cord (Handset)
18257	Card Frame
18397	Card
18398	Protector (Card)
501055	Screws (2) Card Frame

STOCK and CODE NUMBERS

Stock No.	Code	Description
802976	(1234-M)	Less Ringer and Induction Coil

For other Suspended Telephones, see Common Battery Section

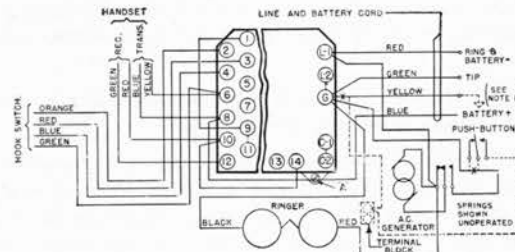
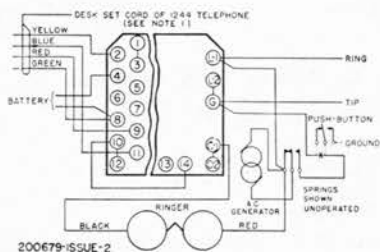

Wiring for Magneto Telephones

## IRONCLAD WEATHERPROOF TELEPHONES

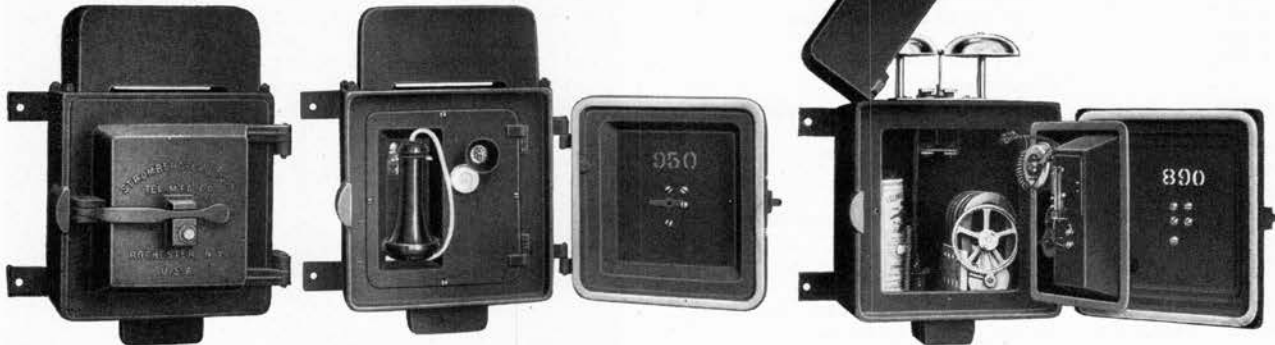

No. 950 BY Ironclad Telephone      Open View No. 950 BY Ironclad Telephone  
No. 890 Generally Similar to the above No. 950.

Showing Inner Compartment No. 890  
Ironclad Telephone

**THE STROMBERG-CARLSON IRONCLAD TELEPHONE** is moisture proof, concussion proof, and weatherproof, built especially for use out-of-doors or in underground localities which require extra high insulation and dependable service. This telephone is available in Central Energy or Magneto models.

**THE CASE** is of heavy cast-iron, provided with outer door, inner door, and gong hood. All parts are heavily coated with rust resisting paint.

When it is desired to keep these telephones locked so that only designated persons may use them, the 11563 Plunger Lock may be replaced with a No. 8468 Key Snap Lock installed at factory.

**THE OUTER DOOR** is equipped with a rubber gasket and compression lever catch, arranged for either key or plunger type lock. Opening the outer door permits the use of the instrument for either signalling or talking.

**THE INNER DOOR** is hinged for opening during repairs, but is at all other times held securely closed by machine screws and a felt gasket. The inner door mounts the transmitter and receiver.

**THE TRANSMITTER** is of the solid back, long distance carbon cup type with a black, phenol compound mouthpiece.

**THE RECEIVER** consists of an outside plastic receiver shell and ear cap and a capsule type receiver unit. The capsule may be changed by removing the ear cap. An automatic cord take-up device prevents the receiver cord being caught when the outer door is closed, following a conversation.

**RINGER** is equipped with loud, clear toned gongs concealed beneath the gong hood. The ringer, clapper rod, and armature are operated by magnetic induction through a tight brass plate. This design permits mounting the ringer coils in a protected position behind the inner door, entirely free from fumes and moisture.

**THE HOOKSWITCH** is of pressure, plunger construction, positive in operation and not dependent on gravity.

**TERMINAL BOX** is mounted on the under side of the telephone, containing two line terminals and a ground terminal, which pass through watertight bushings to the interior of the telephone so that it is unnecessary to open the instrument when making connections. Entrance hole is threaded for 1/2" conduit.

### No. 950 Common Battery Type

The No. 950-BY Telephone is wired for the standard Common Battery Booster Circuit. It is used extensively for out-of-door services such as taxicab stands, police booths, subway service, unheated store rooms, and the like. A No. 44-B Induction Coil is standard in this telephone.

**WEIGHTS** — No. 890 Telephone — 81 lbs. net; packed for shipment, approx. 100 lbs.

No. 950 Telephone — 62 lbs. net; packed for shipment, approx. 78 lbs.

### Parts of No. 950 Telephone

Stock No.	Code	Description
801825	(35-A)	Ringer-less gongs (1000 Ohms)
8437		Gongs (2) 4 inch
1345		Lock nuts (4) used with gongs.
35434		Transmitter (Less back and mouthpiece)
13774		Mouthpiece only
800521		Condenser (1MF)
800425	(44-B)	Induction coil
801595	(30-B)	Receiver with cord (Capsule type)
800627	(M-2-1)	Receiver cord only (22")
33179		Receiver Shell
32864		Earcap
34230		Capsule unit only (30-B receiver)

### Receiver (Present Capsule Type)

Stock No.	Code	Description
801595	(30-B)	Receiver and cord
33179		Receiver Shell
32864		Earcap
34230		Capsule Unit
800627	(M-2-1,22")	Cord (Both types)
9998		Cord take-up reel

### Parts for former 27-B Receiver (Replaced by No. 30-B)

Stock No.	Description
13370	Receiver shell
13371	Earcap
9924	Diaphragm

Complete 30-B and 27-B receivers are interchangeable but components parts are not.

STROMBERG-CARLSON

**IRONCLAD WEATHERPROOF TELEPHONES (Cont.)**

**No. 890 Magneto Type**

This instrument is equipped with a powerful five bar hand generator (Stromberg-Carlson No. 62-A). A No. 26-T Condenser is installed in the receiver circuit so that leaving a receiver off the hookswitch will not interfere with ringing other telephones on the same line. It is equipped with a No. 44-A Induction Coil, and is wired for bridged Magneto service. Space is available for two dry cells.

**Parts of No. 890 Telephone**

Stock No.	Description
	<b>Outer Door</b>
8420	Outer door only
10703	3 ft. soft rubber tubing (Door groove)
10730	Clamp (For holding tubing)
8489	Screws (8) For attaching clamp
11563	Cross-bar locking lever
11413	Steel plunger lock
	Screws (5) Lock

When use of telephone is restricted specify —

8468	Key snap lock (with two keys)
8534	Key only (For 8468 lock)

These locks mount interchangeably.

When a complete outer door assembly is needed, order A-7085-B and specify whether for snaplock or key lock.

**Inner Door**

Stock No.	Description
10636	Inner door only
8535	Felt gasket (Around inner edge)
8438	Screws (4) (Inner door to casing)

When a complete inner door assembly, including all the parts above, is needed order A-7085-B Inner Door.

**Dome and Ringer**

Stock No.	Code	Description
8418		Dome (Top of casing)
3913		Screws (4)
*801826	(35-B)	Ringer 1600 Ohms—less gongs
*801827	(35-E)	Ringer 2500 Ohms—less gongs
8536		Gasket (Under ringer plate)
12272		Coil (2) 800 Ohms (Ringer)
12273		Coil (2) 1250 Ohms (Ringer)
8437		Gongs (2) 4 inch
1345		Lock nuts (4) (Gongs)

\*These ringer assemblies include a solid plate of brass with gong posts attached to the top and ringer coils mounted on the under side.

**Receiver (Present Capsule Type)**

Stock No.	Code	Description
801595	(30-B)	Receiver and cord
33179		Receiver shell
32864		Earcap
34230		Capsule Unit
800627	(M-2-I, 22")	Cord (Both types)
9998		Reel, Cord take-up

**Parts For Former 27-B Receiver**

(Replaced by No. 30-B)

Stock No.	Description
13370	Receiver shell
13371	Earcap
9924	Diaphragm

NOTE—The new capsule type receiver (No. 30-B) is now used on all ironclad telephones. This is interchangeable as a unit with the No. 27-B, but the parts are not.

**Receiver Terminal Post Parts**

Stock No.	Description
10719	Terminal Posts (2)
6209	Screws (2) In recess
6204	Insulations (2) of door
1154	Washers (2)
652	Terminals (2)
2436	Washers (2) In inner
8479	Bushings (2) compartment
2901	Nuts (4)

**Hookswitch**

Stock No.	Description
10818	Hook only (Holds receiver)
8457	Contact spring assembly
8465	Plunger Rod
11414	Screws (2) (Mtg. Hook on door)
	<b>Transmitter</b>
	Description
	Transmitter (less back and mouthpiece)
	Mouthpiece (On inner door)
	Holder (Threaded for mouthpiece)

**Induction Coil**

Stock No.	Code	Description
8636		Induction Coil on Base
800424	(44-A)	Induction Coil only

**Condenser**

Stock No.	Code	Description
800526	(26-T)	½ MF-Rec. circuit

**Generator**

Stock No.	Code	Description
800769	(62-A)	Generator (5 bar)
11346		Insulation (Under generator)
11344		Brass Plate (Generator mounting)
11412		Screws (4) (Generator to plate)
11429		Screws (4) (Plate to casing)
11039		Armature with winding
3556		Magnet (5) (Horseshoe type)
6013		Shunt Spring assembly
246		Clutch (Generator shaft)
4444		Gear, large
11576		Crank and Handle, assembled
11562		Gasket (Round rubber)
3498		Pinion (Small generator gear)
4133		Spring (In recess of pinion)
3497		Stop, (Covering pinion recess)
11674		Hex Screw (For attaching stop)

NOTE—For other generator parts, see Generators in the Coded Parts section under No. 62-A and No. 38 Types.

**Line Terminal Box**

Stock No.	Description
2858	Iron Box only
11412	Screws (4) Box to casing
2985	Terminal Posts (13/16" x ½")
9575	Screws (3) 8/32" x ¾" (Terminal Posts)
2993	Rubber Bushings (3) ⅝" Head
6274	Connectors (3)
11415	Screws (3) In inner
2992	Bushings (3) compartment

**STOCK AND CODE NUMBERS**

Stock No.	Code	Description
802017	(890-I)	1600 Ohm Ringer, 5 Bar Generator
802018	(890-L)	2500 Ohm Ringer, 5 Bar Generator
802046	(950-BY)	1000 Ohm Ringer, 1 MF Condenser

Standard telephone is equipped with plunger lock. When key snap lock with two keys is desired instead of plunger lock, specify No. 8468 Lock.

## FORMER MAGNETO TELEPHONES

### Wall Sets with Oak Cabinets

(These Models are no longer manufactured; parts only are obtainable)

#### No. D-2843 Wall Type

##### Standard Equipment

D-2843 — Wall type Handset telephone, long type Cabinet with battery compartment and inclined writing shelf.

- 41136 (D-2843-I) 5 bar generator, 1600 Ohm ringer
- 41137 (D-2843-L) 5 bar generator, 2500 Ohm ringer

D-2844 — Wall type Handset telephone, short type cabinet; no writing shelf nor compartment for batteries.

- 41689 (D-2844-I) 5 bar generator, 1600 Ohm ringer
- 41690 (D-2844-L) 5 bar generator, 2500 Ohm ringer

#### Used on D-2843, D-2844 Only

##### Handset

Stock No.	Code	Description
801008	(16)	Handset with Cord (1933 Model)
* 42907	(21-A)	Handset with Cord (1940 Model)
800621	(MC-4F, 4' 9")	Brown Cord (For No. 16 and 21-A)
22575		Handle (No. 16 Handset)
32862		Handle (No. 21-A Handset)
24562		Transmitter (No. 16 Handset)
200486		Transmitter (No. 21-A Handset)
23166		Mouthpiece (No. 16)
32863		Mouthpiece (No. 21-A)
66390		Clamping Collar (Mouthpiece No. 16)
34242		Receiver with Earcap (No. 16)
34364		Earcap (Receiver, No. 16)
34230		Receiver-less cap (capsule) No. 21-A
32864		Earcap (Receiver, No. 21-A)

\* For No. 20 Type Handset, complete with black waterproof Cord, Specify:

Stock No.	Code	Description
201498	(21-W)	Handset with WC-4F, 4' 9" Cord
201497	(WC-4F)	4' 9" waterproof black Cord only

##### Hookswitch

13824	Hookswitch (less hook)
27677	Hook only

##### Instrument Cable

35680	Cable Assembly (D-2843)
D-2956	Cable Assembly (D-2844)

#### No. 896 Wall Type

No. 896 Transmitter and receiver separately mounted, long type cabinet with battery compartment and inclined writing shelf.

##### Standard Equipment

- No. 896-I - 5 bar generator, 1600 Ohm ringer
- No. 896-L - 5 bar generator, 2500 Ohm ringer

#### Used on No. 896 Only

##### Receiver (Long Type)

Stock No.	Code	Description
801590	(27-A)	Receiver with cord
800652	(MR-2G)	36" Cord (No. 27-A)
13370		Shell (No. 27-A)
13371		Earcap (No. 27-A)
9924		Diaphragm (27-A)

For replacing complete receiver Specify No. 30 capsule type as follows: —

801593	(30)	Less Cord
801594	(30-A)	With MR-2J, 39" Cord

##### Transmitter

* 802522	(20)	Transmitter with back, and molded mouth-piece front
* 26791		No. 20 Transmitter less back
25600		Molded Mouthpiece front (No. 20)
* The No. 20 Transmitter replaced the No. 7-L Type. The No. 7-L is no longer available but an allowance is made on this old type — less back and mouthpiece — for No. 26791 Transmitter which is the counterpart of the No. 20 Type and mounts in the same back.		

##### Mounting Parts

802528	(19)	Transmitter Arm (No. 20 or 7-L)
12038		Transmitter Back (No. 20 or 7-L)
1266		Screws (2) Back to arm
2525		Screws (4) Transmitter to back

##### Hookswitch

801956	(41-B)	Hookswitch (Springs and Hook)
13824		Hookswitch (Less Hook)
8741		Hook only

The following parts are common to D-2843, D-2844 and No. 896 types of magneto telephones.

##### Generator

201678	(64)	2-bar Alnico type with adapter (replaces No. 38 5-bar generator as a unit).
--------	------	---

##### Parts of No. 38 Generator

Stock No.	Description
3577	Shaft with No. 247 tip (5-bar)
11730	Crank
11039	Armature (5-bar)
3556	Magnets (5)
6013	Shunt Spring
246	Clutch, attached to Shaft by —
245	Cotter pin
278	Collar, attached to large gear by —
4554	Screw
4444	Large gear
4786	Washer (between large gear and clutch)
265	Spring (between large gear and clutch)
3498	Pinion (Small gear)
4133	Spring (in pinion recess)
3497	Stop (over pinion recess)
11674	Hexagon screw (attaches stop)
11673	Washer (Under Hexagon screw)

##### Ringer

801832	(46-C)	Ringer (1600 Ohms) less gongs
801835	(46-F)	Ringer (2500 Ohms) less gongs
12047		Gongs — 2 1/2" (2)
7571		Cap Nuts (2)
1145		Lock Nuts (2)
4241		Mtg. Screws (2)
1120		Washers (2)
5312		Studs (2) For Wood Mounting
12240		Coil, 800 Ohms (2)
12241		Coil, 1250 Ohms (2)
2423		Armature and Clapper rod
577		Adjusting Screw
2580		Pivot screw and nut
8594		Yoke assembled, (including gong posts)

##### Induction Coil

800424	(44-A)	Induction Coil
--------	--------	----------------

##### Condenser and Key

802659	(303)	Push Button Key
800526	(26-T)	1/2 MF Condenser
2494		Clips (3) For Mounting
5202		Screws (3) Condenser

FORMER MAGNETO TELEPHONES (Cont.)

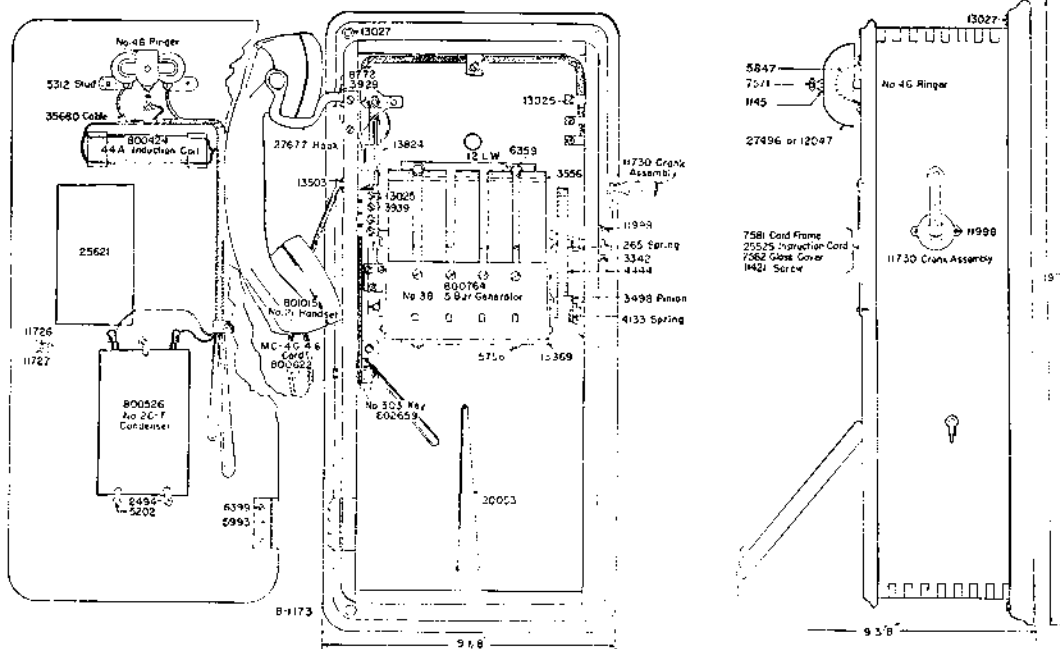

Line Drawing showing Codes and Parts of D-2843 Telephone

62842 (D-2842) Package Assembly

In this package the necessary apparatus is furnished for changing the No. 896 Type, with separate transmitter and receiver, to a wall type handset telephone.

Specify No. 62842 Package which contains handset piece with cord, switchhook and other parts required for this change.

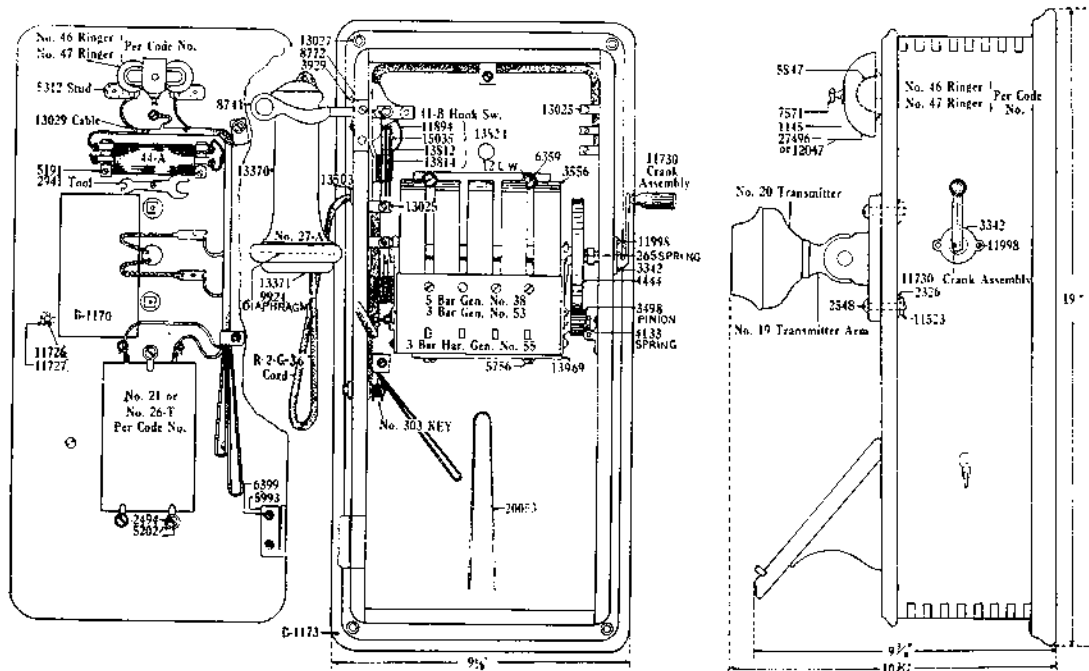

Line Drawing showing Codes and Parts for No. 896 Telephone

## FORMER MAGNETO TELEPHONES (Cont.)

### Desk Set Boxes with Oak Cabinets

**NO. 1180 TYPE MAGNETO DESK SET BOX** which included an induction coil as stand equipment has been replaced by the No. 1268-W with corresponding but more modern equipment. The No. 1180 box was used with the No. 1224-A and 1244 Desk Type Handset Telephones to make two-piece magneto sets.

#### Standard Equipment

- \*802179 (1180-L) 5 bar generator, 1600 Ohm ringer
- \*802180 (1180-L) 5 bar generator, 2500 Ohm ringer

**NO. 327 TYPE MAGNETO DESK SET BOX** does not have an induction coil but in other respects it is similar to the No. 1180 Type. This box is used with magneto telephones having the induction coil in the base such as the No. 992 Desk Stand and the No. 1207 and 1224-B Desk Type Handset Telephones which are no longer manufactured. This box can also be used with the present model No. 1244-B Desk Type Handset Telephone.

#### Standard Equipment

- No. 327-I Alnico generator, 1600 Ohm ringer
- No. 327-L Alnico generator, 2500 Ohm ringer

#### Assembly Parts

Magneto Desk Set Boxes  
Used with Two-Piece Sets

#### Parts of No. 1180 and 327 Types

- No. 46-C Ringer — 1600 Ohms (Less Gongs)
- No. 46-F Ringer — 2500 Ohms (Less Gongs)
- 12240 Coils (2) 800 Ohms
- 12241 Coils (2) 1250 Ohms
- 2423 Armature (Ringer)
- 2580 Screw and Nut (Armature)
- 577 Adjusting Screw

#### Parts used with No. 38 (5-Bar) Generator

- 3577 Shaft with No. 247 Tip (5-Bar)
- 6013 Shunt Spring
- 11039 Armature
- 11730 Generator Crank Assembly

\* The No. 38 Generator is replaced by No. 64 Alnico Generator.

The preceding pages are from Section A of the Stromberg-Carlson General Catalogue, giving description and useful ordering information for Magneto Telephones. Other sections in the catalogue cover Switchboards of all types, Coded Parts, Accessories, Cords, and Construction Materials. Contact your nearest Stromberg-Carlson representative for further information on products listed in this or other sections.

### Handset Telephones used with Two-Piece Sets

- No. 1207 Plastic Housing — Ind. Coil in base (Uses No. 327 D.S. Box)
- No. 1224-A Metal Housing — No induction coil (Uses No. 1180 D.S. Box)
- No. 1224-B Metal Housing — Induction Coil in base (Uses No. 327 D.S. Box)

#### Assembly Parts

Magneto Handset Telephones  
Used with Two-Piece Sets

#### Parts of No. 1207, 1224-A, 1224-B Types

- 24476 Molded Base (1207)
- 23173 Cover (Base) (1207)
- 32883 Zinc Housing (1224-A, 1224-B)
- 32876 Cover (Housing) (1224-A, 1224-B)
- 23111 Plunger (Hookswitch) (1207)
- 32882 Plunger (2) Hookswitch (1224-A, 1224-B)
- MD-4G — 6' 6" Line Cord (1224-A)
- MD-3H — 6' Line Cord (1224-B)
- MD-3G — 5' 3" Line Cord (1207)
- 25677 Induction Coil (1207, 1224-B)

#### Desk Stands With Induction Coil in Base

No. 992 and 1170 — Used with No. 327 Type Desk Set Box. The No. 992 Desk Stand was originally equipped with No. 7-L transmitter (metal front and separate mouthpiece) while the No. 1170 Stand had the present No. 20 type which has the same back and mounts interchangeably.

#### Parts of No. 992 Desk Stand

\* No. 20 Transmitter — complete with combination mouthpiece-front (plastic) and metal back.

- 26791 Transmitter (No. 20 less back)
- 2525 Screws (4) (Transmitter to back)
- 13374 Mouthpiece (No. 7-L Trans.)
- 39-A Induction Coil
- 11675 Bottom Cover
- MD-3-C 6 ft. Line Cord

† Specify No. 20 when complete transmitter, with back, is wanted.

#### Parts of No. 1170 Desk Stand

- 13370 Shell (No. 27-A Receiver)
- 13371 Earcap (No. 27-A Receiver)
- 9924 Diaphragm (No. 27-A Receiver)
- MR-2-G Receiver Cord — 36"
- 6596 Hook (No. 27-A, \*No. 30 Receiver)

\* When complete receiver is wanted the present No. 30 Capsule Type should be specified as follows:

- 801593 (30) Receiver less cord
- 801594 (30-A) Receiver with Cord

**STROMBERG-CARLSON**

# Magneto Switchboards

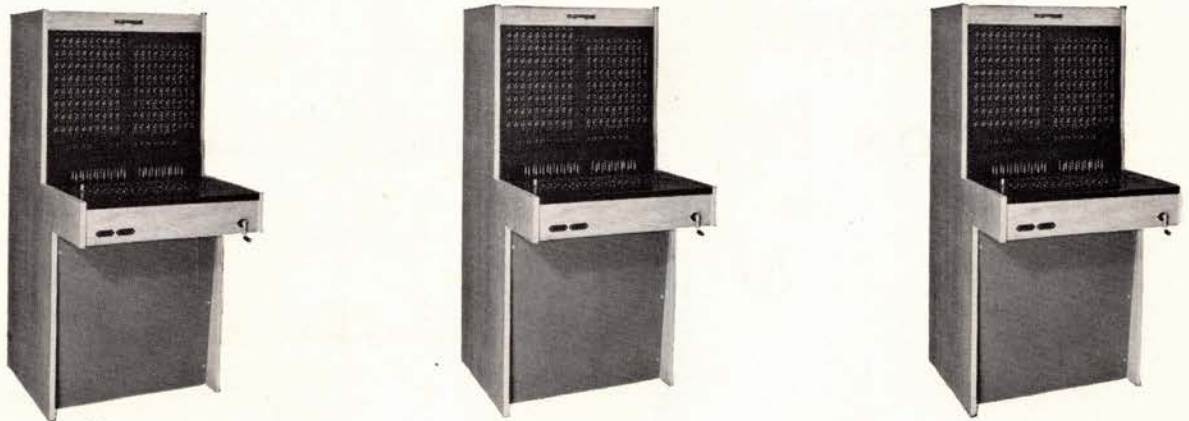

**Rural service with metropolitan efficiency. Public preference permits volume manufacture that speeds delivery and cuts costs.**

CONTENTS  
SECTION B

**MAGNETO SWITCHBOARDS**

	Page
Introduction . . . . .	3b
No. 125 Switchboard . . . . .	4b
No. 126 Drop Line . . . . .	9b
No. A-11740 Ringer Line . . . . .	9b
No. 115 Lamp Line . . . . .	10b
Protector Equipment . . . . .	11b
Use of Common Battery Telephones . . . . .	12b

## MANUAL SWITCHBOARDS

For over half a century Stromberg-Carlson has led the way in the field of quality telephone apparatus. Inherent quality is apparent in the switchboards which have faithfully served the operating companies for so long. The equipment which is being offered today continues to merit the enviable reputation which Stromberg-Carlson has earned in the past.

The present magneto floor model has received such enthusiastic response that large-scale production is possible, with the consequent saving in delivery time and cost. A new, compact magneto wall model is available to meet central office requirements of the very small community. The new section for housing the common battery systems carries out the policy of combining modern appearance with time-proven equipment. A completely modern toll board embodying all the very latest circuit features and operational efficiency is in great demand for the larger exchanges.

Stromberg-Carlson offers stock switchboards to fit a wide variety of operations. It also offers the facilities of a thoroughly experienced engineering staff to equip these boards for meeting your own needs.

Magneto Switchboards are efficiently serving thousands of communities today, particularly in the rural areas where distance is one of the chief obstacles to be overcome. Present demand for Stromberg-Carlson magneto switchboards indicates a continued use of this type of service for many years to come.

The magneto system reduces telephone operation to its simplest elements, so that it is relatively easy to handle in ordinary use or in service inspection. It must stand up under abnormal conditions, since technical service in the areas served is usually at a premium. It must be designed for coupling into dial exchanges where necessary. It must permit growth as the number of subscribers increases.

Stromberg-Carlson has called upon its long experience in the building of manual switchboard equipment to provide for the magneto exchange a switchboard that meets this call for simplicity and reliability. These boards lead the field in economy, speed and efficiency. The large number of repeat orders are the best proof of how well these switchboards are meeting the test of service.

Any community, large or small, which is seeking to modernize its exchange equipment by converting from magneto to common battery will be interested in the Stromberg-Carlson switchboards shown on succeeding pages. There are obvious advantages, such as:

1. Eliminating the use of dry batteries for local service.
2. Maintaining uniform battery supply for local lines.
3. Dispensing with battery replacements on customer's premises.
4. Preventing the annoyance caused by ring-off on rural lines.

The common battery switchboards offered by Stromberg-Carlson are neither complicated nor beyond the means of operating companies. Every detail has been studied to provide a board that has simple circuits, that is easy to maintain, and that compares favorably in price with a good magneto board. A new section design is modern in every respect, more universal in application, and easier to group in multiple form.



Typical Magneto Switchboard

STROMBERG-CARLSON

## MAGNETO SWITCHBOARDS

There are many reasons for the popularity of the new No. 125 Magneto Switchboard. Some of these desirable features are listed below. The net result has been a heavy demand which permits volume manufacture, and brings the switchboard to you in a shorter time at lower cost.

### FEATURES OF THE NO. 125 SWITCHBOARD

1. **DOUBLE CUT-OFF CONTACTS** on each line jack that sever both sides of the drop coil from the line. This guarantees a highly efficient, balanced talking circuit.
2. **UNIT TYPE DROP MOUNTINGS** each containing groups of drops. This facilitates adding extensions in the most practical manner.
3. **DOUBLE RING-OFF SIGNALS** that increase the efficiency of operating by designating to the operator just which party to a connection has rung off.
4. **NON-RING-THROUGH AND REPEATING COIL TYPE CORD CIRCUITS.** This eliminates confusion between operators and subscribers and minimizes noises from inductive disturbances.
5. **MODERN, LONG-LIFE OAK CABINET** is hand-rubbed in limed-oak finish.
6. **LINE DROPS** operate on unusually small amount of current.
7. **THIMBLE OF JACK** separately removable from the front of the switchboard to enable easy replacement of the part most subject to wear.
8. **RING BACK KEY ON EACH CORD CIRCUIT** permits ringing on the answering cord without the inconvenience of reversing the cord connection.
9. **PLUG-RESTORED DROP SHUTTERS** promote speed in operating.
10. **CONTRASTING COLOR OF SHUTTER**, when operated, provides easy visibility and increases efficiency.
11. **REMOVABLE NUMBER PLATES** make it convenient to properly designate lines to conform with directory listings.
12. **REMOVABLE DROP COILS** permit economical repairs.
13. **CODE ALARM** provided on any line, when specified, by the use of a drop equipped with code alarm contacts.
14. **MANUALLY RESTORED RING-OFF SHUTTERS** designate which subscriber to a connection is ringing off.
15. **ZERO-LOSS CORD CIRCUIT**—The first two cord circuits on the left are wired for this feature. Repeating coil cut-off keys are required for this service.

### Cabinet Design

**WOODWORK** thoroughly seasoned, kiln-dried oak with No. ES-629 limed oak finish provides an attractive durable cabinet.

**FLUSH DESIGN** allows sections to fit together, presenting the appearance of one continuous switchboard when more than one section is installed.

**DROP FRAME** of steel construction, affords a support for the line signals as well as a rigid bracing for the switchboard cabinet.

**PHENOLIC VENEER** covering the keyboard provides a dull black finish which successfully resists the effect of wear.

**FIBROUS VENEER** over the plugboard combats the wearing effect of plug impacts.

**SHORT CORD REACH** adds to ease of operating.

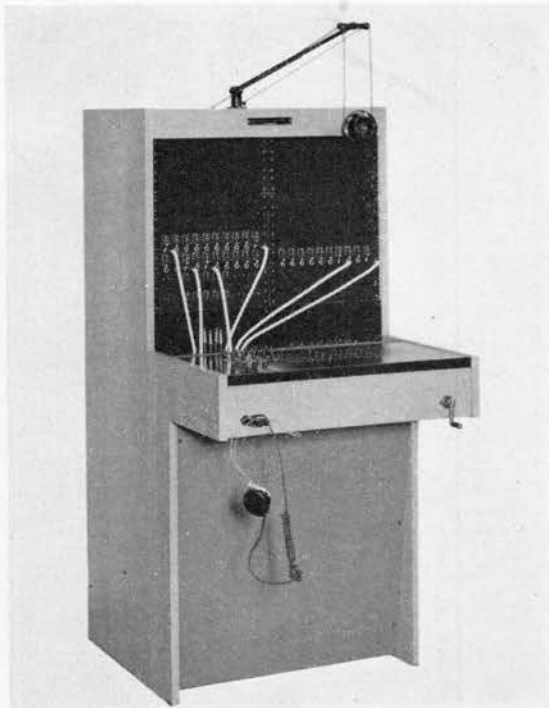

Front Perspective of No. 125 Switchboard  
Capacity 150 Lines, 15 Cord Pairs

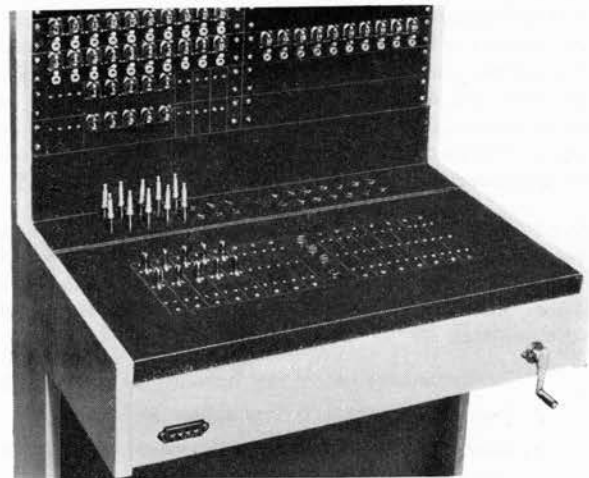

Keyboard of No. 125 Switchboard

**WIDE KEYBOARD** furnishes convenient writing space and adds to comfort of the operator.

**REMOVABLE PANELS**, front and rear, permit inspection of interior equipment.

**LOW KEYBOARD** allows operator to rest her feet naturally on the floor when sitting in a working position at the switchboard.

**DIMENSIONS:** Overall height 54"; height to top of keyshelf 30 $\frac{1}{8}$ "; width 25"; depth including keyshelf 31 $\frac{3}{4}$ ".

**NO. 125 MAGNETO SWITCHBOARD (Cont.)**

**Line Equipment**

Each equipped line circuit of the No. 125 Switchboard includes:

Stock No.	Code	Description
801789	(No. 18-B)	Drop, less Code Alarm or
801798	(No. 23-B)	Drop, with Code Alarm
	Mounted on	
37197	(No. 147)	Drop Mounting, 10 per strip

See coded Parts Section for codes covering 10 drops on one strip.

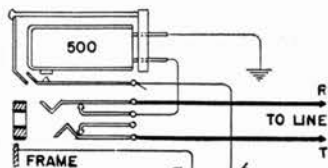

Line Circuit arranged for central checking line

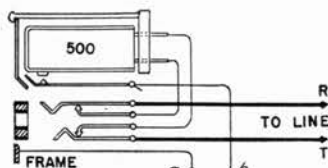

Line Circuit of No. 125 Switchboard with double cut-off jacks

**FULL METALLIC LINE CIRCUIT WIRING** with looped-in wire for connecting ground to drop as required, provides facilities so that any signal in the switchboard may be associated with a grounded line, a metallic line, a common return line, or a central checking line.

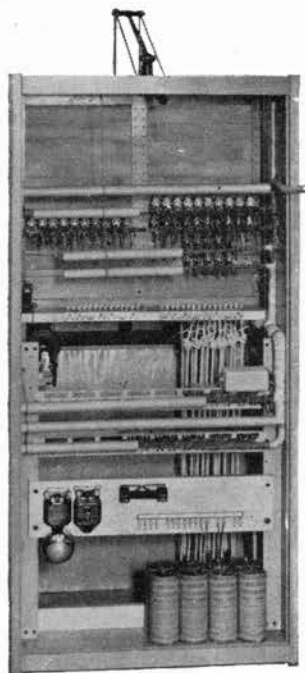

Rear View of No. 125 Switchboard, arranged to bring cable out at top or bottom of switchboard

**CODE ALARM** provided on any line, when specified, by the use of a drop equipped with code alarm contacts. Micrometer type adjustment permits accurate code alarm operation; or, if desired, the entire removal of this feature from the drop signal. Code Alarm Contacts may readily be added to any line drop signal originally furnished without this feature. Thus a No. 18 Type Drop may be changed to a No. 23 Type by adding the contact assembly described under "Coded Parts." See "Drop Signals."

**LINE CABLE**, which may be extended 12 feet from either the top or bottom of the switchboard, affords ample length for connecting to a standard Stromberg-Carlson No. 1 Protector Frame.

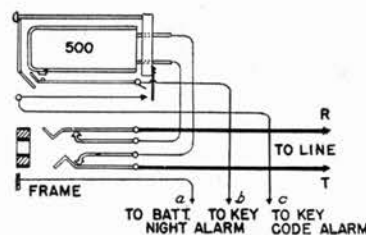

Line Circuit showing drop arranged for Code Alarm

**Night Alarm and Code Alarm Circuit**

Standard No. 125 Switchboards are equipped with straight Night Alarm Circuits and wired for Code Alarm. Code Alarm equipment is provided only when specified.

**THE NIGHT ALARM CIRCUIT**—This circuit is arranged to give a continuous ring as long as a drop shutter remains in the operated position, and while the Night Alarm Key is in the operated position.

**THE CODE ALARM CIRCUIT**—This circuit provides a buzzer which buzzes in unison with the code signals when a subscriber rings on a party line. The operator thus knows whether her services are required when a drop falls, or whether the call is simply for another party on the line.

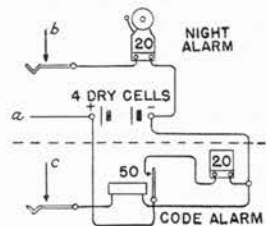

Night Alarm and Code Alarm Circuit

**Equipment Required**

Stock No.	Code	Description
<b>Night Alarm</b>		
38346	(No. 571)	20 ohm 2 1/2" Vibr. Bell
49532	(No. 338-C)	Key (Night Alarm)
<b>Code Alarm</b>		
39483	(No. 570)	20 ohm Buzzer
49532	(No. 338-C)	Key (Code Alarm)
803054	(No. 265Z-A)	Relay
801610	(No. 25)	Relay Casing

## NO. 125 MAGNETO SWITCHBOARD (Cont.)

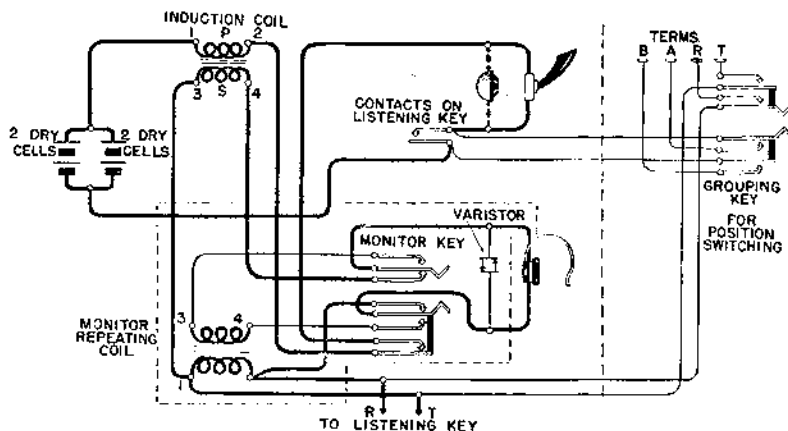

Operator's Circuit showing Monitor and Varistor Circuit as well as Grouping Key

### Operator's Telephone Equipment

A suspended operator's telephone set is regularly furnished with the No. 125 Switchboard. The following apparatus is included:

Stock No.	Code	Description
801592	(No. 29)	Receiver
801470	(No. 23)	Plug
800646	(No. MO-2-1)	4 ft. Cord
	(No. 6)	Dry Cells (4)
801082	(No. 93)	Jack
802527	(No. 15)	Transmitter Arm
800424	(No. 44-A)	Induction Coil
802525	(No. 22)	Transmitter
800632	(No. MO-1-A)	5 ft. Duratex Cords (3)

The following items are furnished only when specified: 802632 (No. 188-A) Key and 800443 (No. 14-AL) Repeating Coil for Monitor Equipment and 66241 (No. 3-A) Varistor for "click" reduction; 801083 (No. 93-B) Jack for Learner accommodation.

This operator's equipment has the following features:

**CONVERTIBLE**—The wiring is arranged so that a breast plate type transmitter may be readily substituted for a suspended type, in which case a No. 4 Operator's Telephone Set is specified.

**CONVENIENT**—The quickly removed head band and the handy cut-in plug, regularly furnished, are especially convenient for the attendant who has various duties other than those of operating and who, therefore, frequently has occasion to leave the switchboard.

**MONITOR AND VARISTOR**—Each switchboard is wired so that a monitor key and associated equipment may readily be installed when the operating requirements demand this service. A varistor across the receiver may also be used to aid in dispelling annoying clicks.

When push-button telephones are used on subscribers lines, the standard No. 18-B single-wound drop should be replaced by the No. 18-D double-wound drop; or the single-wound coil alone may be taken out and replaced by the double-wound coil.

### Generator and Power Equipment

The apparatus furnished for ringing the subscriber's station instruments consists of:

Stock No.	Code	Description
800764	(No. 38)	Generator
37258		Crank Shaft
11730		Crank
49532	(No. 338-C)	Key (Gen)
801822	(No. 28-H)	Ringer

**POWER RINGING GENERATOR**, such as the Type "S" Sub-Cycle Ringing Machine, is recommended for the busy switchboard. It speeds up service during the rush hours and lightens the operator's work. The switchboard is wired and arranged for connecting with standard power ringing supply sources.

**EMERGENCY RINGING** is accomplished by means of the 800764 (No. 38) powerful five-bar generator. The No. 338-C Key provides a means of switching from hand generator current to power generator current as required. See circuit diagram.

**SIGNALLING INDICATION** is given by means of a buzzer which responds to the flow of current in the generator circuit. This indicates to the operator that she is ringing out on a line and that the line is in proper condition for signalling. This buzzer tone is particularly helpful to the operator when ringing code signals.

**MASTER KEY SPACE** on the keyboard affords a means for installing the following ringing facilities in the switchboard: Divided Circuit Ringing, Pulsating Ringing, or Harmonic Ringing.

**OPERATOR'S CIRCUIT POWER SUPPLY**, such as the 1057-R Rectifier, is recommended, when the building lighting circuit is constant. This type of current supply is equipped with a change of source relay, so that a stand-by set of dry cells may be switched into service in case of city power failure.

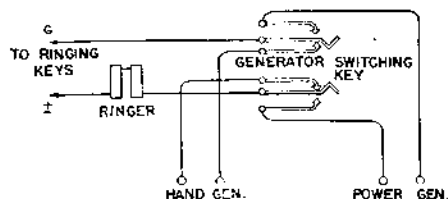

Generator Switching Circuit

NO. 125 MAGNETO SWITCHBOARD (Cont.)

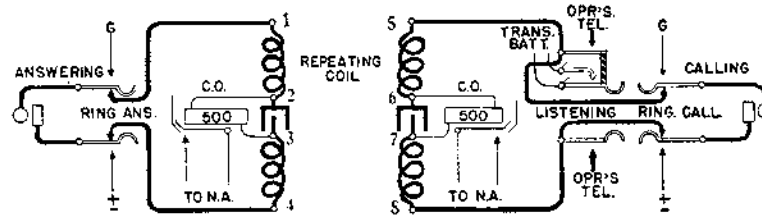

Standard Cord Circuit with Repeating Coil and Double Clear-out Drops

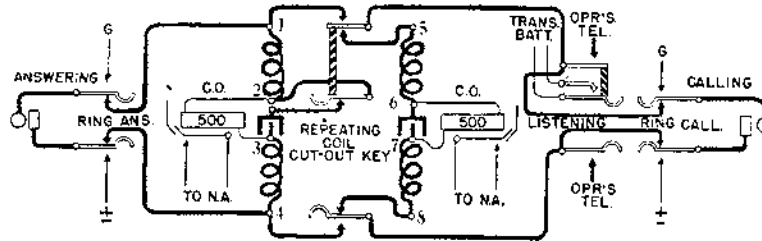

Cord Circuit with Repeating Coil, Double Clear-out Drops, and Repeating Coil Cut-out Key  
Wiring supplied in first two circuits only

Cord Circuit Equipment

The cord circuits of the No. 125 Magneto Switchboard are designed for accurate, efficient operating and reliable service. Each circuit includes the following equipment:

Stock No.	Code	Description
800577	(No. 5-22-F)	5 ft. Duratex Cords (2)
801497	(No. 56-X)	Plugs (2)
800707	(No. 6)	Cord Weight (2)
*802994	(No. 332)	Key
802627	(No. 178-A)	Key
	on	
801292	(No. 89)	Key Mounting
801794	(No. 21-B)	Drops (2)
801811	(No. 148)	Drop Mtg., 10 per (2)
800440	(No. 13-AL)	Repeating Coil
42375	(No. 61)	Condenser

\*Specify 803021 (No. 333) Key when repeating coil cut-out key is desired in first two cord circuits only.

Dial Trunks

When the No. 125 Magneto Switchboard connects with a Dial Exchange, it is necessary to provide for dial trunks. Wiring is provided in each switchboard for dial, dial cord, dial jack, and wipe-out key. These items can readily be installed in standard switchboards without major alterations.

Material Required for Dial Cord

Stock No.	Code	Description
800577	(No. 5-22F)	5 ft. Cord
801497	(No. 56-X)	Plug
800707	(No. 6)	Cord Weight
49520	(No. 336-C)	Key Engr. "WO"
42376	(No. 62)	Condenser (Dial as required)

Material Required for Either Simplex or Loop Line Trunk  
(Mounted in face of switchboard)

Stock No.	Code	Description
801794	(No. 21-B)	Drop
41154		Line Jack
41155		Dial Jack
41153		Mounting Strip

No. 41092 is complete assembly for one trunk.

No. 41093 is complete assembly for two trunks.

To complete a Simplex Dial Trunk the following additional material is required:

Stock No.	Code	Description
41065	(No. 1471)	Applique Cable
800436	(No. 11-AL)	Repeating Coil
802384	(No. 2-A)	Terminal Block

No. 18 Type Repeating Coil, or equivalent, to be mounted outside of switchboard.

To complete a Loop Dial Trunk:

Stock No.	Code	Description
41065	(No. 1471)	Applique Cable
800436	(No. 11-AL)	Repeating Coil
802384	(No. 2-A)	Terminal Block
42371	(No. 56)	Condensers(2)

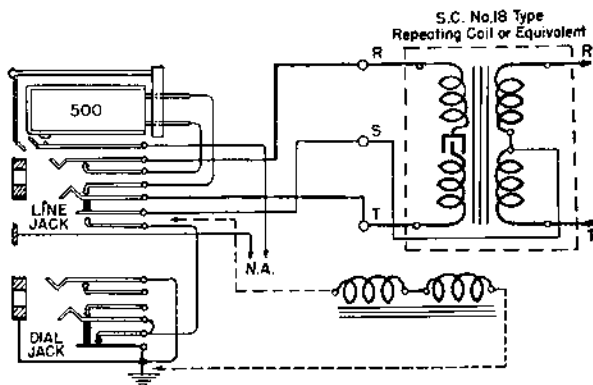

Simplex Dial Trunk Circuit

This switchboard should be located:

- 1—As close as possible to entering lines or cables.
- 2—In a position that permits room for growth.
- 3—In a room with windows lighting the face equipment.

## NO. 125 MAGNETO SWITCHBOARD (Cont.)

### Grouping or Position Switching Key

A switchboard consisting of two or more positions requires facilities for switching the operator's set of one position to the cord circuits of an adjacent position and vice versa. Such facilities are essential particularly during light periods when it is desirable to have one operator handle two or more positions. This purpose is accomplished by means of what is known as a "Grouping" or "Position Switching Key." The No. 125 Magneto Switchboard is drilled, blanked and wired for a Position Switching Key which may be installed readily at any future time when it is needed. The requirements consist of one No. 338-H Key.

### No. 125 Switchboard Tools No. 41307 Package Assembly

Stock No.	Code	Description
802456	(No. 2)	Socket Wrench
41140		Wrench for Arm. Nut
802485	(No. 56)	Screw Driver
8104		Screw Driver C. A.
2941	(No. 14)	Flat Wrench
12077	(No. 42)	Screw Driver
892713	(No. 90)	Yankee Screw Driver, 3" blade
802457	(No. 7)	Spring Adjuster

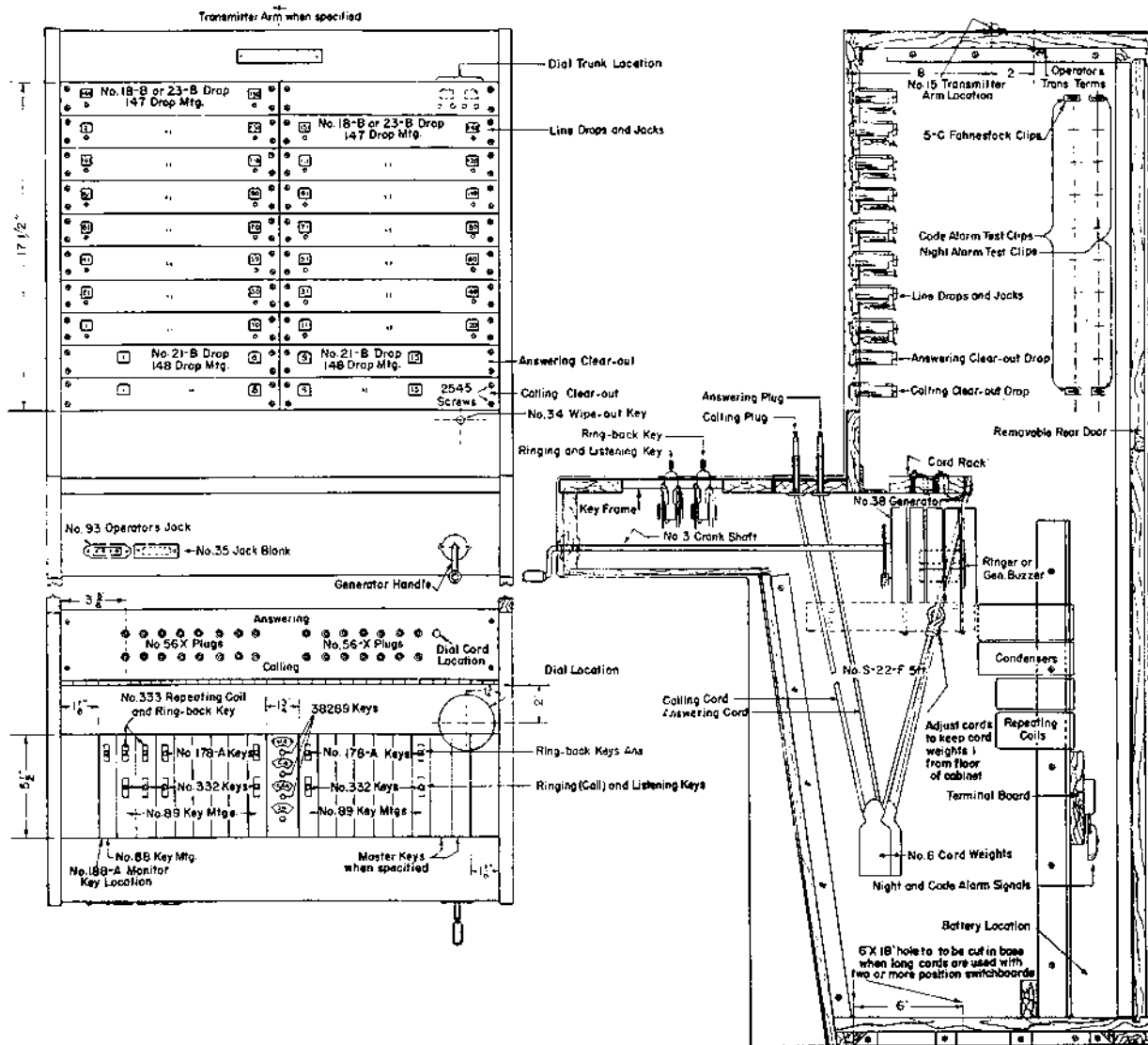

Details of No. 125 Switchboard

WALL TYPE MAGNETO SWITCHBOARDS

No. 126 Switchboard

This is a compact wall type switchboard especially designed to meet the telephone switching requirements of many communities that are not large enough for more complete central office equipment.

The hinged cabinet swings out from the backboard to permit easy access to all apparatus as well as the wiring which is formed into a 15 pair machine-made cable extending 12 feet from the back of the switchboard. The woodwork is kiln-dried quartered oak with dull golden finish.

The No. 126 Switchboard is wired for an ultimate capacity of 15 full metallic lines, 3 pairs of connecting cords and 1 answering cord. Two standard sizes are stocked:

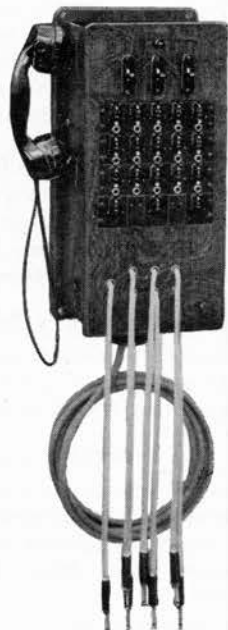

No. 126 Magneto Switchboard  
Capacity—15 Drop Lines

No. 126-A Switchboard

- 10 Plug-restored drop lines
  - 2 Connecting cord pairs with single ring-off drop
  - 1 Answering cord
- Approx. shipping wt. 60 lbs.

No. 126-B Switchboard

- 3 Connecting cord pairs with single ring-off drop
  - 1 Answering cord
  - 15 Plug-restored drop lines
- Approx. shipping wt. 65 lbs.

Cabinet dimensions: Height 19", Width 8 7/8", Depth 7"

Circuit Equipment

Line Equipment

Stock No.	Description
200429	No. 18-B Drop with impregnated coil
200435	Drop mounting (mounts 5 drops)

Connecting Cord Equipment

Stock No.	Code	Description	Stock No.	Code	Description
200430	(S-22-F)	Cord, 2' Long	33991	(133)	Key Mounting
801495	(56)	Plug	801794	(21-B)	Ring-off Drop
802705	(342-BX)	Key (Cam type)	200436		Drop Mounting, 3 drops

Answering Cord Equipment

200430	(S-22-F)	Cord, 2' long	801495	(56)	Plug
--------	----------	---------------	--------	------	------

Operator's Equipment

Stock No.	Code	Description	Stock No.	Description
801015	(21)	Telephone Handset	13825	Hookswitch Asm. (Less Hook)
800424	(44-A)	Induction Coil	27667	Hook only

Generator Equipment

800764	(38)	Generator	11730	Generator Crank
--------	------	-----------	-------	-----------------

Night Alarm Equipment

201738	(334-C)	Key marked N. A. (Push type)	200502	Vibrating Bell (Scharze 500)
--------	---------	------------------------------	--------	------------------------------

Code Alarm Equipment

The No. 126 Switchboard is wired for code alarm and, when specified, designated lines will be equipped with the following apparatus for this special service.

Stock No.	Code	Description
200911		Vibrating Buzzer (Scharze 501)
201742	(334-C)	Key marked C. A. (Push type)
803054	(265Z-A)	Relay
801610	(25)	Relay Casing
801665	(93-L)	Relay (Angle) Mounting

Accessories:

Protector Equipment

801558 (69-B) Carbon block and Mica fuse protectors in strips of 10 pairs on maple base with associated jumper strip. Designed for wall mounting.

Power Ringing Equipment

Model S Sub-cycle Ringing Machine operating from 105-125 Volt, 50 or 60 cycle A.C. which delivers ringing current at a frequency of 20 or 16 2/3 cycles. Non-interfering to radio reception.

No. A-11740 Switchboard

This switchboard, designed for use with any standard magneto wall telephone, is an ideal board for very small communities, as calls may be handled without an operator in constant attendance.

The A-11740 Wall Type Switchboard comes fully wired and equipped with 5 ringer lines and associated drop shutters, 2 connecting cord circuits, 1 answering cord circuit and 1 night alarm. Approximate shipping weight 35 lbs. Two of these switchboards may be mounted side by side when more than five lines are to be connected.

The cabinet is of kiln-dried, quarter-sawed oak with dull golden finish. It has a hinged door with screw lock and mounts in a space 9 3/8" x 17 3/8". A five pair line cable extends the line wiring 12 feet from the rear of the switchboard.

Each of the 5 lines is equipped with a 1600 ohm two-gong ringer with numbered drop shutter and a line jack. These audible signals, supplemented by the night bell, when necessary, attract the operator's attention and when a subscriber rings central the drop shutter will fall to indicate the number of the line on which the call is received. Each line circuit includes: 201853 (102-C) Ringer Drop and Shutter Assembly, and 801072 (55) Line Jack.

The two Connecting Cord Circuits provide facilities for carrying on two separate conversations at the same time.

Each circuit includes two 44067 (S-23-G) 2 ft. Cords, two 801481 (42) Plugs.

The Answering Cord, between the two pairs of connecting cords, is used for answering calls, ringing subscribers, and for supervising connections. This circuit includes: 44067 (S-23-G) 2 ft. Cord, 801481 (42) Plug, two 801072 (55) Listening Jacks.

Operator's Equipment consists of any standard wall type magneto telephone from which two wires should be run to the two terminals in the switchboard marked "Oper. Tel."

The Night Alarm consists of a 20 ohm bell and controlling push type Switching Key marked "N. A."

## NO. 115 LAMP SIGNAL MAGNETO SWITCHBOARD

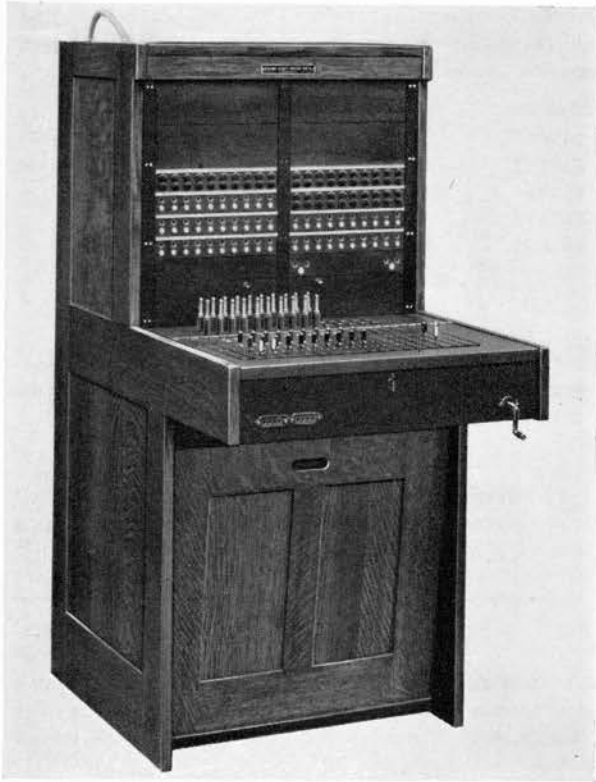

Front Perspective No. 115 Switchboard

### Features of the No. 115 Switchboard

The outstanding feature of this switchboard is the use of lamps for both line and ring-off signals. Other points of merit are:

- Double lamp cord circuit supervision,
- Keyboard supervision on all cord circuits,
- Repeating coils in every cord circuit,
- Non-ring-through cord circuits,
- Minimum loss cord circuits for toll connections,
- Positive code ringing indication on rural lines,
- Common battery operator's transmitter to assure constant transmission efficiency.

### Capacity

These switchboards are wired for the full capacity of 20 long lines, 140 short lines, and 15 cord circuits. They are built to order, and equipped to meet the customer's requirements.

### Cabinet

Steel frame construction with quarter-sawed oak woodwork. Flush end panels give a continuous face when adding sections. Black formica on the keyboard and black fibrous veneer on the jack face are both attractive and durable. The hinged keyboard and swinging relay gate make servicing easy.

### Line Equipment

Two types are provided: the short lines where the operator does all the ringing, and the long lines for multi-party service with facilities for code ringing between stations. The equipment features individual jack and lamp sockets, relays so arranged that the operator receives a signal when one station calls another on the same line, and double cut-off jacks.

### Cord Circuit Equipment

Non-ring-through repeating coil type. The key equipment consists of a single ring-back key and a combined ringing and listening key. Double lamp ring-off signals, mounted in the keyboard, indicate which party to a call has signalled.

### Operator's Telephone Equipment

The operator's telephone equipment is the standard No. 4 Common Battery Operator's Set, with breast type transmitter, head receiver, cord, plug, and 4-point jack.

### Generator and Power Equipment

For single party ringing a Sub-Cycle Static Frequency Converter is recommended. This operates from 110-115 volt 60 cycle supply. For 4-party harmonic ringing a battery operated converter is recommended, which can be cut out when ringing is not required.

Emergency ringing is provided through the No. 38 Hand Generator, which may be switched in or out as needed.

The recommended power plant is a Cat. No. RCR-1066 Raytheon Recticharger which is plugged into the building lighting circuit. The output circuit is attached permanently to the terminals of sealed-in type batteries such as the CTMH-2.

### Night Alarms and Code Alarm Circuits

The night alarm is a vibrating bell operating from the line lamps and the cord ring-off lamps. The code alarm gives a buzz in unison with signals of one subscriber calling another subscriber on the same line.

### Optional Equipment

Position Switching Key is provided for, if two or more positions are in use.

Transmission Test Equipment and Cord Test Circuits may be installed as additional items to set up artificial line conditions for testing by the operator.

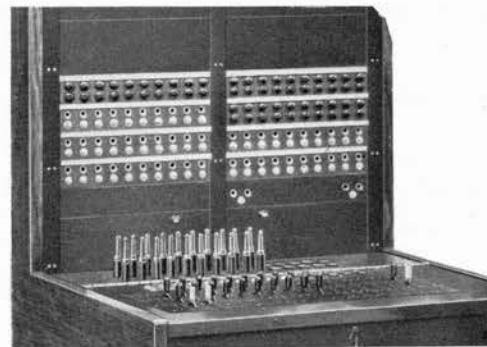

Keyboard of No. 115 Lamp Signal Switchboard

MAGNETO SWITCHBOARDS—PROTECTOR EQUIPMENT

Mica Fuse and Carbon Block Type

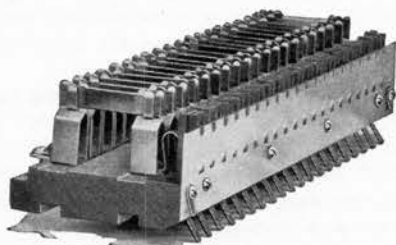

No. 12606 Protector Strip

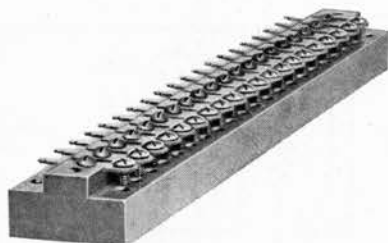

No. 12607 Protector Strip

No. 69 Type Protector

The Stromberg-Carlson No. 69-A Protector is designed especially for use in Magneto Exchanges. It is of the well-known carbon block and mica-protected fuse type. Mounts 50 pairs high on the Stromberg-Carlson No. 1 Floor Type Protector Frame which should be specified for installations of the No. 125 and No. 115 Magneto Switchboards.

The No. 69-B Wall Mounting Type Protector is recommended for the No. 126 Magneto Switchboard.

Stock No.	Code	Description
801557	(69-A)	Used with Floor Type Frame
801558	(69-B)	Used with Wall Type Frame

Stock No. 801557 (No. 69-A) Protector consists of 1 No. 12606, 10 pair Carbon Block and Mica Fuse Strip and 1 No. 12607, 10 pair Jumper Strip complete with Western Union Type Fuses. Both units mount side by side on the face of No. 1 Protector Frame.

Stock No. 801558 (69-B) Same as No. 69-A except mounts on hard maple sub-base side by side for wall installations.

Protector Parts

Stock No.	Pairs per Strip	Description
12606	10	Protected Strip less Fuses
12607	10	Jumper Strip
12614		Carbon Blocks
12625		Dielectrics
		¼ amp. Fuses-quantities of 100

Other Type Frames

Sometimes other than mica fuse protectors are desirable, especially when power circuits are close enough to the central office equipment to cause trouble from "sneak" currents.

Under these conditions a wall or floor type frame with heat coil and carbon block protectors is recommended. The verticals, as well as the switchboard, should be so located that the cable will reach farthest protector without splicing.

Protector Frame—Floor Type

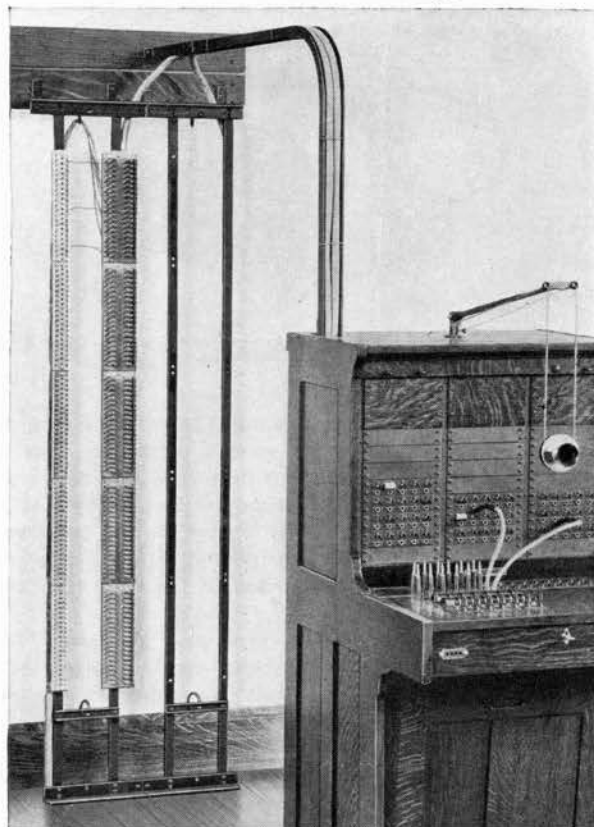

Two No. 1 Protector Frames and No. 1 Cable Rack Installed with No. 125 Switchboard.

The Stromberg-Carlson No. 1 Protector Frame is of the sectional wall type and is therefore of flexible capacity.

It is built for Nos. 125 and 115 Magneto Switchboards, but is adaptable to any Magneto Switchboard installation.

Each Protector Frame Unit mounts 50 pairs of No. 69-A Protectors.

For a 50 line installation order 1 No. 1 Protector Frame. For a 100 line installation order 2 No. 1 Protector Frames, and so on to any desired capacity.

This Protector Frame makes a remarkably neat and practical installation at a very low cost.

Stock No.	Code	Description
801599	(1)	Floor Type Protector Frame

Stock No. 801559 (No. 1) Unit Type Protector Frame 50 lines capacity mounts 5 No. 69-A Protectors.

Protector Frame to Switchboard Cable Rack

The Stromberg-Carlson No. 1 Cable Rack is designed for carrying overhead the cabling between a No. 125 or No.115 Switchboard and an associated No. 1 Protector Frame. The Cable Rack is constructed of heavy channel iron, rust proofed, and painted black. It is equipped at the frame end with wall mounting brackets and at the switchboard end with brackets for the roof of the switchboard. One No. 1 Cable Rack is required for each switchboard section.

Stock No.	Code	Description
800152	1	Channel Iron Cable Rack

## COMMON BATTERY TELEPHONES USED WITH MAGNETO LINES



The Stromberg-Carlson No. 1243-W Handset Telephone is the ideal Common Battery Telephone for use with Magneto Lines.

Companies which operate magneto switchboards are requested many times to provide a service which approximates common battery operation. When a bank, a busy store or a residence telephone subscriber desires to signal the operator by simply removing the telephone from the hookswitch, in the same manner as the city subscriber, this type of service is possible with any standard magneto switchboard line at a minimum installation cost.

Usually, the service applies to single party town lines. The service can be started with one line and more lines added from time to time, as the occasion demands. The installation of these lines is a valuable sales aid when the operating man wishes to change complete equipment from magneto to common battery.

The simplicity of changes necessary for providing common battery type of service in magneto switchboards is clearly indicated in the following diagram and lists of equipment. One of the prime essentials is to select an efficient repeating coil, so that the talk-through and ring-through features are capable of the best transmission.

One set of dry batteries used with one medium length line will last approximately one year; with two medium lines, approximately five months. When more lines are added, it is recommended that consideration be given to the use of:

11 Cells CTMH-2 Storage Batteries No. RCR-1066 Recticharger  
The above equipment is satisfactory up to 20 lines.

If central energy telephones are being installed in a magneto exchange which contemplates a quick change to common battery operation then equipment of enough capacity to handle the entire exchange is recommended, such as:

11 Cells PTMH-2 Storage Batteries No. RCR-1066 Recticharger

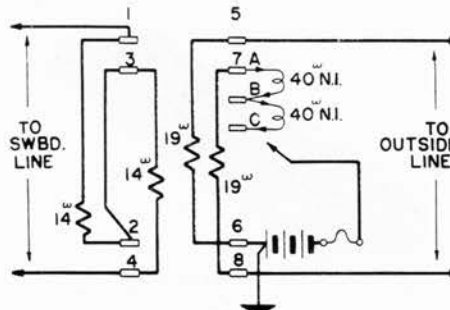

No. 16-AL Talk-Through, Ring-Through Repeating Coil, Connection Diagram

### Connection Instructions

Connect battery to 7-A, -B or -C of Repeating Coil in accordance with the resistance of the line. For town lines, the No. 11-A Repeating Coil may be used satisfactorily with a series non-inductive resistance of 80-100 Ohms such as our No. 11-H Resistance Coil. This coil should be connected in series with one of the line windings and the ungrounded side of battery, to limit the transmitter current.

When used on Short lines the two 50 Ohm windings of the No. 11-H Resistance Coil should be series connected but on lines of medium length only one winding (50 Ohms) is needed.

On long lines the No. 11-H Resistance Coil should be omitted.

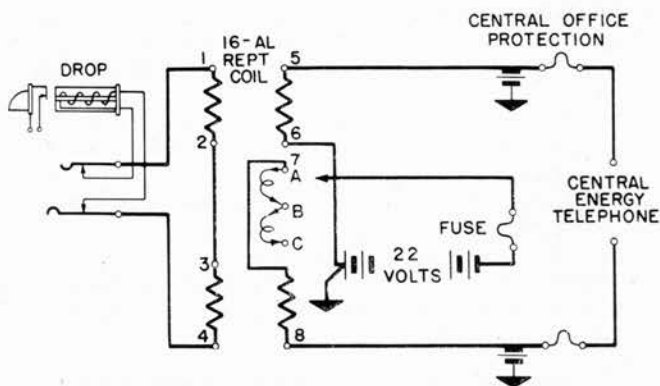

Magneto Line Circuit arranged for service with Common Battery Telephones

### Equipment

A typical list of equipment used in making a central energy line conversion follows:

- No. 1243-WA Handset Telephone
- No. 975-H Reliable Protector
- No. 16-AL Repeating Coil
- No. 48 Fuses (2)

No. 6 Dry Cells (16)

No. 85 Relay Mounting Strip (Mounts 10 Repeating Coils)

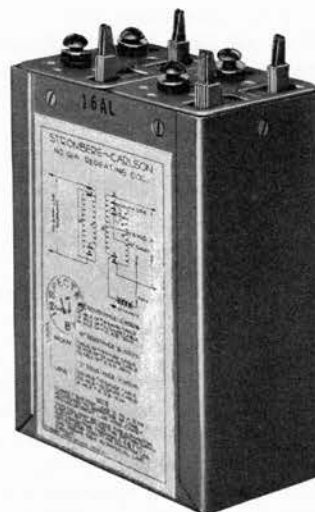

The Stromberg-Carlson No. 16-AL Repeating Coil which makes possible the use of Common Battery Telephones with Magneto Lines.

**STROMBERG-CARLSON**

# Coded Parts

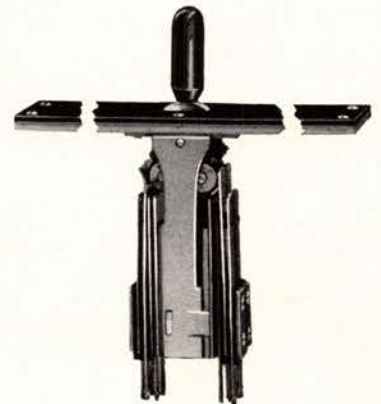
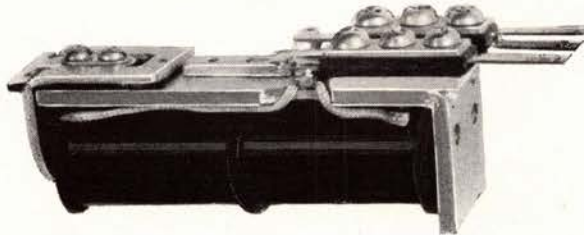

**Stromberg-Carlson Coded Parts are sub-assembly units most frequently ordered for expansion or replacement in standard switchboards, telephones and their major components.**

CONTENTS  
SECTION F

**CODED PARTS**

---

	Page
Blanks, Apparatus .....	3f
Coils .....	4f
Condensers .....	11f
Designation Strips .....	13f
Dial Mountings .....	14f
Distributing Bars .....	14f
Drops .....	15f
Footrails and Brackets .....	18f
Frames, Card .....	45f
Fuses, Alarm and Protection .....	18f
Generators, Hand .....	19f
Holly Strips .....	20f
Hookswitches, Hooks .....	21f
Jacks .....	22f
Keys .....	29f
Key Boxes .....	43f
Lamps, Switchboard .....	45f
Lamp Caps and Sockets .....	46f
Operator's Telephone Sets .....	49f
Plugs, Plug Seats .....	50f
Receivers .....	53f
Relays and Relay Coils .....	55f
Ringers .....	67f
Terminal Equipment .....	73f
Tools, Switchboard and Telephone .....	74f
Transmitters and Arms .....	76f
Visual Signals .....	78f

---

**CODED PARTS  
FOR TELEPHONE AND SWITCHBOARDS**

For convenience in ordering replacements or adding to existing equipment, the most generally used parts and sub-assemblies—as well as complete apparatus—have been given code numbers. Code numbers are plainly stamped on the parts, so that replacements can usually be made by number and name of part. The necessary hardware for mounting is included in all shipments under code number.

For additions or replacements on older installations it is advisable to give the switchboard, telephone or other equipment for which the apparatus is needed, as the original parts may have been replaced by more modern equivalents. Many items cannot be described in complete detail in this catalogue. Your nearest Stromberg-Carlson representative will help you find the parts best suited to your own needs.

The coded parts shown here are arranged alphabetically so that they can be found easily; cross references are given where there might be alternate locations.

**ARRESTERS**

See Protectors

**ARMS, TRANSMITTER**

See Transmitters

**BLANKS**

Blanks are available for neatly filling unequipped apparatus spaces of switchboard and other telephone equipment. Many different types are made for stock. Blanks which can be furnished are: Drop Blanks, Jack Blanks, Key Blanks, Plug Hole Blanks.

**DROP BLANKS**—These blanks are available for covering the space required for one signal only or for groups of 5 or 10 signals on mounting plates used, in standard switchboards.



A Typical Drop Blank

**JACK BLANKS** are available in many sizes and styles for a wide variety of uses. They are used to fill the space of a single strip of jacks, or of combined lamp and lamp strips; also to fill the space of multiple jacks or multiple lamp and jack strips.

Many of these blanks are faced with black formica in a smooth, satin finish. Others are finished in golden oak, birch, mahogany, or dull walnut to meet specific needs. Some are edged with a white holly strip.



A Typical Jack Blank

**KEY BLANKS** to fill the space of key mountings. Both flush and surface mounting types can be furnished for Nos. 340 and 170 Type Cam Keys.



A Typical Key Blank assembled

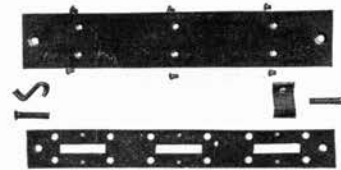

A Typical Key Blank unassembled

Flush mounting key blanks are made with a steel top, covered with formica in a smooth satin finish. These blanks require 2 No. 12908 Machine Screws and 2 No. 12672 Clamps for mounting to the key frame.

Surface mounting Key Blanks are black enamel finished and require 2 No. 5502 Wood Screws for wood mounting or 2 No. 6714 Machine Screws for mounting to metal.

**PLUG HOLE BLANKS** to fill the space of switchboard plugs, of individual lamp sockets, and of individual round barrel keys.

Plug Hole Blanks are made of black composition material or fibre. They preserve the neat appearance of a switchboard, and prevent dust or dirt from settling in unequipped openings.



A Typical Plug Hole Blank

**CIRCUIT PLATES**

See Catalogue Section on Common Battery and PBX Switchboards.

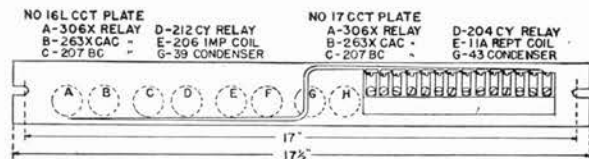

## COILS—IMPEDANCE

Stock numbers, when associated with code numbers, cover completely assembled coils and parts for mounting. The stock numbers of coils indicate coils only, of the standard resistances specified.

### No. 10 Type

This type impedance coil has an open magnetic circuit with two windings, parallel wound. Used in old style key boxes for selective talking, selective ringing intercommunicating systems. No. 4 x 1/4" RHIW screw used for mounting.



No. 10 Type

Stock No.	Code	Approximate Resistance
800265	(10-A)	35 x 35 Ohms
800266	(10-B)	100 x 100 Ohms

### No. 13 Type

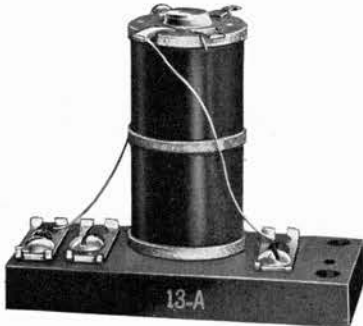

No. 13 Type consists of a No. 10-A Impedance Coil mounted on a maple base equipped with terminals. Has open magnetic circuit. One of these coils is used in each old style common talking, selective ringing intercommunicating system for feeding battery current. Mounts with two No. 8 R.H.I.W. screws.

Stock No.	Code	Approx. Resistance	Overall Dimensions
800268	(13-A)	35 x 35 Ohms	1 3/8" x 2 7/8" x 1 11/32"

### No. 17 and 20 Type

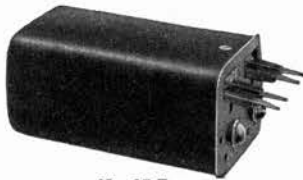

No. 17 Type

Nos. 17 and 20 Type Impedance Coils have cross-talk-proof shells similar to No. 25 Relay Casing. Mount on steel plate uniformly with a pair of No. 200 Type Relays. Used in common battery switchboards.

Stock No.	Code		Ohms Resistance
800270	(17-AL)	Closed Mag. Cct.	40 x 40
800272	(17-CL)	Closed Mag. Cct.	200 x 200
800274	(17-DL)	Closed Mag. Cct.	85 x 85
800276	(17-FL)	Broken Mag. Cct.	440
800280	(20-AL)	Broken Mag. Cct.	85 x 85

NOTE—Furnished with aluminum casing.

### No. 18 Type

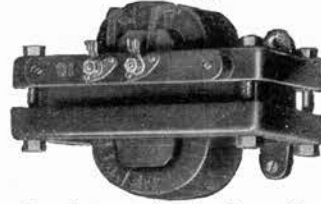

This coil has a closed magnetic circuit, and is designed especially for use as a "Noise Killer" in connection with Harmonic Converters. Consists of a single winding of very low resistance and high impedance over a core made up of transformer iron laminations mounted in an iron frame. Arranged to mount on either Power Boards or Converter Control Panels. Space occupied—4 3/4" x 7" x 7".

Stock No.	Code	Ohms Resist.	Description
800277	(18-A)	1	Harmonic Converter Mounting Centers, 4 1/8" x 3 1/4"
800278	(18-B)	.2	Single Frequency Converter Mounting Centers, 4 1/8" x 3 1/4"

### No. 22 Type

This Impedance Coil is designed for use with a Harmonic Converter to suppress radio interference.

Stock No.	Code	Inductance
800282	(22)	5 Millihenrys at 10 <sup>3</sup> cycles per second

### No. 200 Type

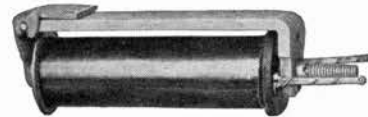

Consists of the Stromberg-Carlson standard No. 200 Type Single Wound Relay Coil with iron frame. Has closed magnetic circuit, but requires the No. 25 Relay Casing to become cross-talk-proof. Mounts on steel plate uniformly with No. 200 Type Relays.

Stock No.	Code	Ohms Resistance	Stock No. Coil Wound
800288	(201)	5	12276
800289	(202)	15	12277
800290	(203)	70	12278
800291	(204)	100	15491
800292	(205)	200	12280
800293	(206)	500	12266
800294	(207)	1000	12267
800295	(209)	1500	12282
800296	(213)	320	15435
800297	(214)	2000	15436

### No. 220 Type

The No. 220 Type Impedance Coil is similar to the No. 200 but equipped with two windings in tandem.

Stock No.	Code	Ohms Resist.	Stock No. Coil Wound
800300	(222)	100 x 100	12287
800301	(223)	200 x 200	12288
800302	(224)	500 x 500	12289
800303	(225)	1000 x 1000	12290
800304	(228)	8 x 8	12279
800306	(243)	100 x 350 N.I.	15197
201126	(245)	500 x 2000 N.I.	15199
800307	(249)	500 x 5000 N.I.	28268

COILS—IMPEDANCE (Cont.)

No. 300 Type



The No. 300 Type, Iron-clad cross-talk-proof Impedance Coil is used with No. 200 Relay and No. 25 Casing.

Stock No.	Code	Ohms Resistance	Winding	Stock No. Coil Wound
800309	(303)	50	Single	28725
800310	(304)	100	Single	15491
800311	(306)	500	Single	12266
800313	(321)	25 x 25	Tandem	28814
800315	(323)	200 x 200	Tandem	12288
800316	(325)	1000 x 1000	Tandem	12290
800317	(326)	50 x 50	Tandem	12291
800318	(352-L)	100 x 100	Parallel	34430

No. 500 Type

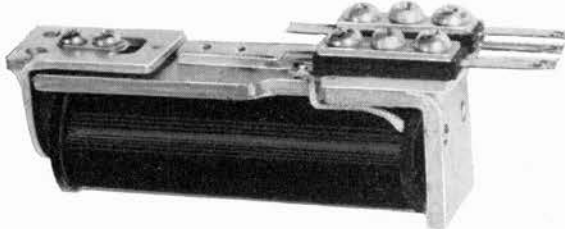

This Impedance Coil has a permanently closed magnetic circuit. It is constructed and mounts similarly to the No. 500 Type Relay.

One Inductive Winding

Stock No.	Code	Ohms Resistance	Stock No. Coil Wound
800320	(501)	5	32501
800323	(504)	100	32504
800324	(505)	200	32505
800325	(506)	500	32506
800326	(507)	1000	32507
800327	(508)	800	32508
800328	(509)	1500	32509
800329	(510)	5000	32510
800330	(511)	25	32511
800332	(513)	320	32513
800333	(514)	2000	32514
800335	(516)	1120	32516

No. 520 Type

Tandem Wound  
Two Inductive Windings

Stock No.	Code	Ohms Resist.	Stock No. Coil Wound
800342	(523)	200 x 200	32523
800343	(524)	500 x 500	32524
800344	(525)	1000 x 1000	32525
800345	(526)	2000 x 2000	32526

Parallel Wound  
Two Inductive Windings

Stock No.	Code	Ohms Resist.	Stock No. Coil Wound
800350	(531)	25 x 25	32531
800352	(533)	225 x 225	32533
800353	(534)	150 x 150	32534
800354	(535)	100 x 100	32535
800355	(536)	200 x 200	32536
800356	(537)	50 x 50	32537
800357	(538)	500 x 500	32538

No. 500 Type (Cont.)

Concentric Wound  
One Inductive Winding  
One Non-Inductive Winding

Stock No.	Code	Ohms Resist.	Stock No. Coil Wound
800363	(544)	500 x 350 N.I.	32544
800365	(546)	200 x 60 N.I.	32546
800366	(547)	100 x 1000 N.I.	32547
800367	(548)	500 x 500 N.I.	32548
800368	(549)	1000 x 1000 N.I.	32549
800369	(550)	200 x 2000 N.I.	32550
800370	(551)	1000 x 200 N.I.	32551
800371	(552)	1000 x 2000 N.I.	32552
800372	(553)	2000 x 500 N.I.	32553
800373	(554)	1000 x 500 N.I.	32554
800374	(555)	2000 x 2000 N.I.	32555
800375	(556)	500 x 1000 N.I.	32556
800376	(557)	320 x 350 N.I.	32557

Concentric Wound  
Two Inductive Windings

Stock No.	Code	Ohms Resist.	Stock No. Coil Wound
800380	(561)	500 x 1000	32561
800381	(562)	500 x 100	32562
800382	(563)	200 x 500	32563
800383	(564)	175 x 2100	32564
800384	(565)	100 x 10000	32565
800386	(567)	250 x 670	32567
800389	(570)	500 x 2000	32570
800390	(571)	1000 x 2000	32571
800391	(572)	200 x 2000	32572
800392	(573)	200 x 1000	32573

Concentric Wound  
Three Inductive Windings

Stock No.	Code	Ohms Resist.	Stock No. Coil Wound
800400	(581)	1000 x 1000 x 1000	32581
800401	(582)	1000 x 2000 x 2000	32582
800402	(583)	250 x 250 x 250	32583

"A" Relay Type Impedance Coil

These impedance coils mount like "A" Type Relays. They are used in XY Systems with No. 36676 Bracket which will mount two coils of this type or one coil and one condenser.

Single Wound Coil

One Inductive Winding

Complete Coil Stock No.	Ohms Resistance	Coil Wound Stock No.
36298	1350	36817
36299	560	36815
36300	350	36814
36304	27	36808

Concentric Wound Coil  
Two Inductive Windings

36291	2.5 x 130	36889
36292	38.7 x 38.4	36890
36294	1310 x 2020	36884
36295	0.10 x 200	36898

Parallel Wound Coil  
Two Inductive Windings

36293	175 x 175	36961
36296	1200 x 1200	36969
36297	280 x 280	36963

The above coils are equipped with armatures and have a permanently closed magnetic circuit.

The following coils are assembled without armatures and are inductively wound:

Complete Coil Stock No.	Ohms Resistance	Coil Wound Stock No.
36301	1310 x 2020 (concentric)	36884
36302	2120 (single)	36818
36303	79 x 2020 (concentric)	36893

## IMPEDANCE COIL MOUNTINGS

The No. 175 Impedance Coil Mounting is a right angle bracket; used to mount Impedance and Resistance Coils individually, but it can also be used for other purposes where this design of mounting is needed. Made of Steel with Parker Finish. Furnished with one No. 8 x 1/2" F.H.I. Wood Screw and one No. 8-32 x 1/4" F.H.I. Machine Screw.

Stock No.	Code	Mounts	Dimensions
740	(175)	Impedance Coils—No. 1 or 10 type, also Resistance Coils—Nos. 10 and 11 Types	Each arm—Length, 1 1/16" Width—1/2" Thickness—1/8"

### Other Mountings

No. 17, No. 20, No. 200, and No. 300 Type Impedance Coils mount on standard relay mounting strips used for mounting

No. 200 Type Relays. No. 500 Type Impedance Coils may be mounted on mountings which take No. 500 Type Relays.

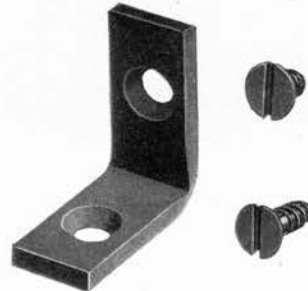

No. 175 Mounting

## COILS—INDUCTION

### No. 38 Type



No. 38 Induction Coil

Originally made with wooden spool heads, these coils are now equipped with phenolic heads. They require two clamps for mounting; Nos. 15640 and 15641. The No. 38-A is used with Common Battery Desk Stand, Nos. 988, 989 and 990 and Hook-switch Box Nos. 19, 28 and 29. The No. 39-A is used with Magneto Desk Stand Nos. 991, 992 and 993 and Hookswitch Box No. 36.

Stock No.	Code	Approximate Resistance		Turns Ratio
		Primary	Secondary	
800420	(38-A)	32 Ohms	48 Ohms	1:1
800421	(39-A)	1.7 Ohms	19.5 Ohms	1:4.36

### No. 44 Type

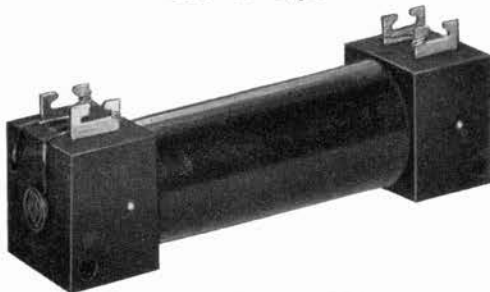

No. 44 Type Induction Coil

The No. 44-A Induction Coil is used in No. 896 and D-2843 Telephones, No. 1180 Desk Set Boxes and in No. 105 and No. 125 Switchboards. The No. 44-B is used in the booster talking circuits of No. 1155 and No. 1157 Wall Telephones and No. 1156 Desk Set Box. The No. 44-D is used in anti-side-tone circuits. The No. 44-E is used in switchboards in the busy test portion of operator's circuits. Mounting space 4 3/16" x 1 7/16" x 1 1/8".

Stock No.	Code	Windings	Approximate Resistance		Tertiary
			Primary	Secondary	
800424	(44-A)	2	2.2 Ohms	12.9 Ohms	None
800425	(44-B)	2	14.3 Ohms	8.9 Ohms	None
800427	(44-D)	3	11.3 Ohms	62.0 Ohms	56.0 Ohms
800428	(44-E)	2	2.59 Ohms	106.9 Ohms	None

### No. 45 and No. 46 Types



No. 45 Ind. Coil

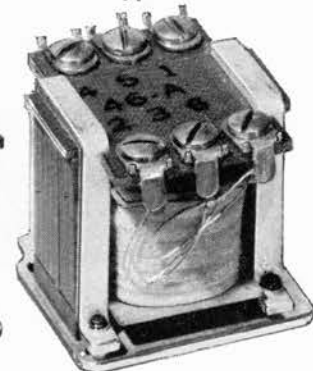

No. 46-A Ind. Coil

Coils of this type are of a design resembling that used in highly efficient radio audio transformers. Three windings are used in anti-side-tone circuits, correctly proportioned to give the best results in transmitting and receiving service. The windings are well insulated and then treated to exclude moisture. The laminations are butted and clamped with their edges in line.

The No. 45-A (23124) Induction Coil is used in the anti-side-tone circuits of Nos. 1210, 1211, 1212 and No. 1191 Telephones.

The No. 45-B (25677) Induction Coil is used in the circuit of the magneto telephone No. 1207.

The No. 46-A (32943) Induction Coil is used in the anti-side-tone circuits of Nos. 1222 and 1223 Telephones.

The No. 46-B Induction Coil is used in magneto telephones or in telephones with local battery talking and common battery signalling.

Stock No.	Code	Windings	Windings		
			Primary	Secondary	Tertiary
23124	(45-A)	3	8.0 Ohms	29.0 Ohms	44 Ohms
			296 Turns	579 Turns	405 Turns
No. 32 AWG No. 34 AWG No. 36 AWG Turns Ratio, Coils 1-2:3-4 as 1:1.9					
25677	(45-B)	2	.74 Ohms	9.5 Ohms	
			87 Turns	375 Turns	None
No. 26 AWG No. 30 AWG Turns Ratio, Coils 1-2:3-4 as 1:4.3					
32943	(46-A)	3	536 Turns	378 Turns	213 Turns
			No. 33 AWG No. 34 AWG No. 38 AWG	Turns Ratio, Coils 1-2:3-4:5-6 as 2.5:1.8:1	
800432	(46-B)	4	70 Turns	296 Turns	157 Turns
			No. 30 AWG	No. 34 AWG	No. 36 AWG
None-Ind. 49 Turns No. 36 AWG					

COILS—INDUCTION (Cont.)

No. 47 Induction Coils

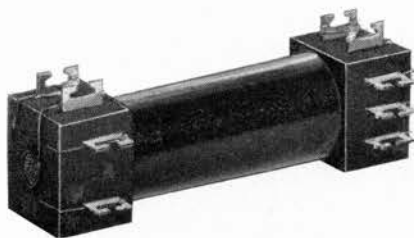

No. 47 Induction Coil

No. 47 Type Induction Coils replace former No. 42 Types for PBX and Multiple Switchboard Circuits. When they are used to replace present installed No. 42 Type Coils, the condenser in the battery feed (primary) side of the circuit should be changed from 2mf to 3 mf. Mounting space 4 3/16" x 1 9/16" x 1 9/16".

Stock No.	Code	Windings	First, P-P	Second, LT-T	Third, T-L
800433	(47-A)	3	2.03 Ohms	450 Ohms	28.4 Ohms
			523 Turns	1165 Turns	2180 Turns
			No. 25 AWG	No. 36 AWG	No. 28 AWG
				Plus 82-T	
				No. 40 Res. Wire	
				Turns Ratio, LT-L:P-P as 6.6:6.84	

Stock No.	Code	Windings	Description
800434	(47-B)	5	First, Second & Third Windings same as 47-A
			Fourth, Mon. Fifth, Test
			73.8 Ohms 77.0 Ohms
			686 Turns 686 Turns
			No. 36 AWG No. 36 AWG

No. 200595  
Induction Coil and Capacitor Assembly



This assembly consists of induction and capacitor units embedded in a sealed plastic housing filled with hydrolene which is a viscous, tar-like compound. This process assures complete protection against moisture and the excessive humidity of hot climates.

Screw terminals, properly numbered, are mounted at each end of the housing for connecting the line and handset cords, and also the wiring from the induction coil and capacitors.

Used with both common battery and magneto equipment, this compact unit will mount in present types of desk set boxes as well as wall and desk type handset telephones. This adaptation for various purposes assures operating convenience and economy, especially in changing instruments from one type of service to another.

No. 200595 Assembly is used as follows:

Type of Service	Desk Set	Wall Set	D.S. Box
Common battery	1243, 1247	1250	1260
Magneto	1248	1258	1268

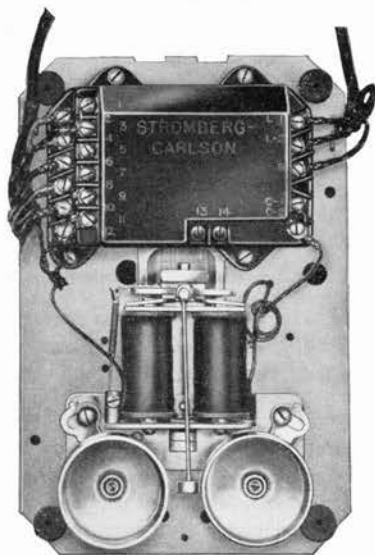

Common Battery Base showing use of No. 200595 Induction Coil and Capacitor Unit

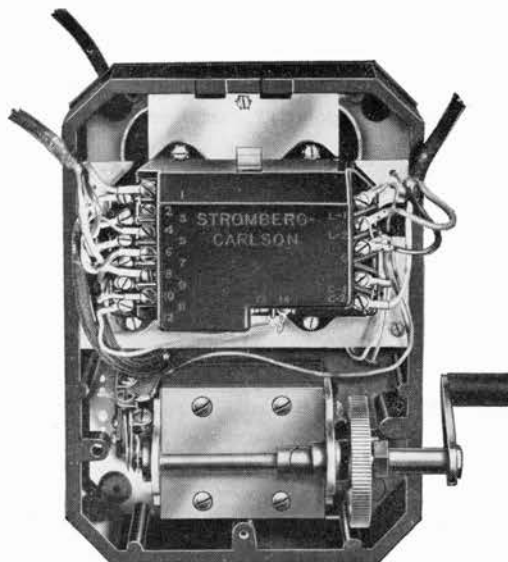

Magneto Base using the same No. 200595 Induction Coil Unit

## COILS-REPEATING

### No. 11-A Talk-Through Type

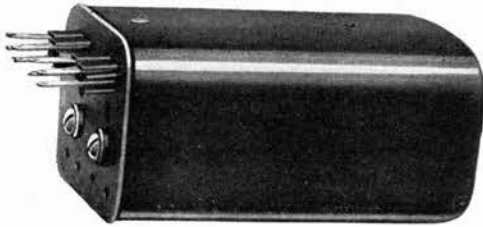

No. 11 Type Repeating Coil

A highly efficient "Talk-Through" Type Repeating Coil for toll service, also for cord, trunk and other circuits, where it is necessary to establish connections between dissimilar lines, such as—common battery to magneto, grounded to metallic, and unbalanced to balanced. The high frequency bridged loss, when used for the above-mentioned purposes, is remarkably low—approximately 0.4 miles of standard cable.

This Repeating Coil has four concentric windings, brought out to eight terminals, and mounts on steel plates uniformly with the Nos. 200 or 500 Type Relays.

Dimensions of case over terminals: Length, 4 25/32"; width, 2 27/64"; height, 1 55/64".

Stock No.	Code	Use	Resistance Between Terminals
800436	(11-AL)	Common Battery Exchange	Ter. 1 and 2—15.6 Ohms Ter. 3 and 4—16.5 Ohms Ter. 5 and 6—19.4 Ohms Ter. 7 and 8—20.2 Ohms

Turns Ratio: Coils 1-2:3-4 as 1:1

Turns Ratio: Coils 5-6:7-8 as 1:1

NOTE—Furnished with aluminum casing.

### No. 13-A Non-Ring-Through Talk-Through Type

A Non-Ring-Through, Talk-Through Repeating Coil, unexcelled for talking efficiency as well as Non-Ring-Through properties; guaranteed to prevent the passage of sufficient ringing current through a cord circuit to operate either a ring-off signal or to tap a ringer on any subscriber's telephone. Similar in appearance to the No. 11-A Repeating Coil. Occupies the space of one relay casing, and mounts on steel plates with the same mounting centers as employed for the No. 200 Type Relays. Dimensions of case over terminals: Length, 4 25/32"; width, 2 27/64"; height, 1 55/64".

Stock No.	Code	Use	Resistance Between Terminals
800440	(13-AL)	On universal Cord Circuits and on Magneto Switch-boards.	Ter. 1 and 2—15.6 Ohms Ter. 3 and 4—16.5 Ohms Ter. 5 and 6—19.4 Ohms Ter. 7 and 8—20.2 Ohms

Turns Ratio: Coils 1-2:3-4 as 1:1

Turns Ratio: Coils 5-6:7-8 as 1:1

800441 (13-ALF) Same as 13-AL except that the shell is filled with wax to prevent lamination chatter.

NOTE—Furnished with aluminum casing.

### No. 14 Repeating Coil (Impedance Type)

Similar in appearance and same size as No. 13 Repeating Coil, but used for electrical impedance in operator's circuits.

Stock No.	Code	Description
800443	(14-AL)	Monitor Impedance Turns Ratio: 1:5

NOTE—Furnished with aluminum casing.

Mounts uniformly with a pair of 200 Type Relays under one relay casing.

For other "repeating type" coils used for electrical impedance, see Impedance Coils—No. 17 and 20 types.

### No. 15 Type Repeating Coil

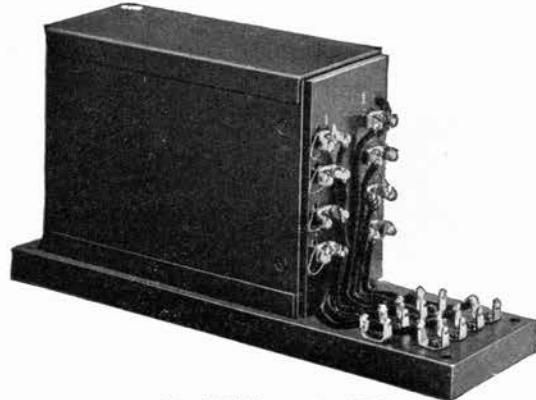

No. 15-BY Repeating Coil

Number 15 Type Repeating Coils are made up of No. 18-A Type Units. See Description of the No. 18 Repeating Coil for coil characteristics.

Stock No.	Code	Description
800447	(15-BL)	Same as No. 18-A except mounts on flat surface. Designed for outdoor use.
800449	(15-BYL)	Uses 1 No. 15-BL Coil mounted on wood sub-base for Phantom use. Length, 8 3/4"; width, 2 1/2"; height, 4 17/64".
800448	(15-BXL)	2 No. 15-BL Coils mounted on wood sub-base for Phantom use. Length 10 3/4"; width, 4 7/8"; height 4 17/64".

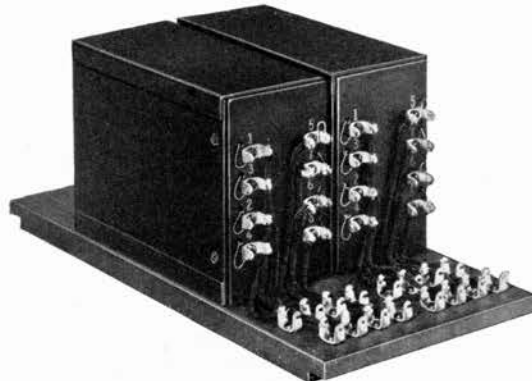

No. 15-BX Repeating Coil

### No. 16 Type Repeating Coil

Stock No.	Code	Description
800450	(16-AL)	Ring-Through, Talk-Through, and Phantom Coil, with built in 40 Ohm Resistances. Used extensively as kick coil when Common Battery Telephones are employed on Magneto lines.

For use of No. 16-AL Repeating Coil in connection with common battery see Switchboard Section of Catalogue.

### No. 17 Type Repeating Coil

This Repeating Coil is used as a tone coupler, such as for the All Links Busy tone in Relaydial. Its construction is similar to the No. 13-AFL previously described. Mounts uniformly with a pair of 200 type relays under one casing.

Stock No.	Code	Description
800452	(17-AL)	Used for Tone Coupler Turns Ratio: 5-6:1-2-7-8 as 8:1

NOTE—Furnished with aluminum casing.

**COILS—REPEATING (Cont.)**  
**No. 18 Type Repeating Coil**

The No. 18 Repeating Coil is used for Ring-Through and Talk-Through service in Phantom, Simplex, and Composite circuits. The line windings are balanced electrically as to resistance, capacity, and impedance. This coil is very efficient in both talking and ringing transmission—high frequency losses are less than 0.35 d.b. Encased within a cross-talk-proof steel shell, it may be mounted on a wood base for relay rack mounting or in the rear of a switchboard on a relay gate. It is also drilled and tapped to receive machine screws for securing to a shelf or wooden base. Dimensions of case over terminals: Length, 6 3/8"; width, 2 27/64"; height, 3 13/16".

No. 18 Type Repeating Coils mount on one No. 85 or two No. 87 relay mounting strips.

Stock No.	Code	Use	Approximate Resistance Between Terminals
800453	(18-A)	To form Phantom, Simplex, and Composite Circuits.	Ter. 1 and 2—14 Ohms Ter. 3 and 4—14 Ohms Ter. 5 and 6—15 Ohms Ter. 7 and 8—15 Ohms

Impedance ratio between windings 1-2, 3-4 and 5-6, 7-8 as 1:1. The No. 18-A is designed for use with terminations, 600 Ohms and 600 Ohms.

Stock No.	Code	Use	Approximate Resistance Between Terminals
800454	(18-B)	Same as above.	Ter. 1 and 2—14 Ohms Ter. 3 and 4—14 Ohms Ter. 5 and 6—20 Ohms Ter. 7 and 8—20 Ohms

Impedance ratios between windings 1-2, 3-4 and 5-6, 7-8 as 1:1.5. No. 18-B is designed for use with termination, 600 Ohms and 900 Ohms.

Stock No.	Code	Use	Approximate Resistance Between Terminals	Ratio of Turns 1:1
800455	(18-C)	Same as above	Ter. 1 and 2— Ter. 3 and 4— Ter. 5 and 6— Ter. 7 and 8—	

Impedance ratio between windings 1-2, 3-4 and 5-6, 7-8 as 1:1. The No. 18-C is designed for use with terminations, 1200 Ohms and 1200 Ohms.

Stock No.	Code	Use	Approximate Resistance Between Terminals
200934	(18-F)	Same as above	Ter. 1 and 2—14 Ohms Ter. 3 and 4—14 Ohms Ter. 5 and 6—15 Ohms Ter. 7 and 8—15 Ohms

Impedance ratio between windings 1-2, 3-4 and 5-6, 7-8 as 1:1. The No. 18-F is designed for use with terminations, 600 Ohms and 600 Ohms.

**Typical Circuit Diagrams, showing Use of No. 15 and No. 18 Type Repeating Coils.**

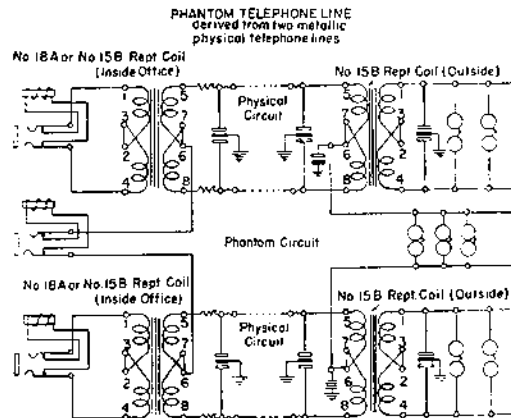
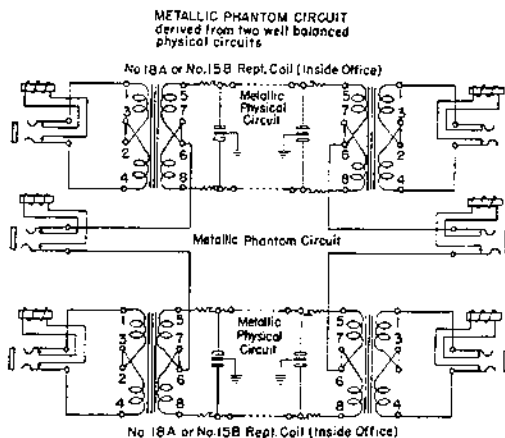
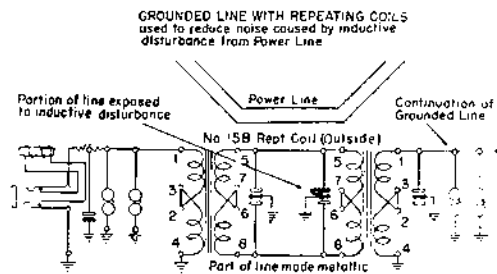
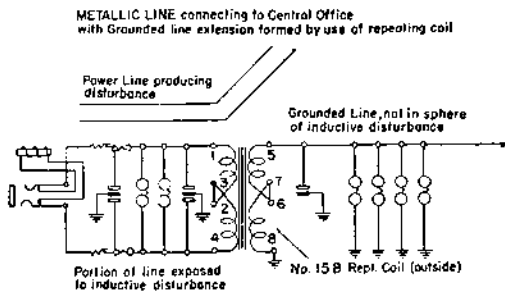

## COILS—RESISTANCE

Stromberg-Carlson resistance coils have a sufficiently large carrying capacity and radiating surface to prevent overheating when used in the circuits for which they are designed. These resistance coils are wound non-inductively upon rigid and heat conducting core with special high grade resistance wire.



No. 10 Resistance Coil

### No. 10 Resistance Coil

No. 10 Type Resistance Coils can be used on the same mountings as No. 200 Type Relays. The parts for mounting should be ordered separately as No. 203539 Package Assembly which includes the following items:

- 1—No. 525063 Hex Nut
- 1—No. 525643 Washer
- 1—No. 1096 Bushing
- 1—No. 6019 Washer

All coils are single-wound, non-inductive.

### No. 10—Single Wound

*Coil Only Stock No.	Code	Resistance Ohms
15710	(10-A)	1000
15711	(10-B)	3000
15714	(10-C)	100
15715	(10-D)	200
15712	(10-E)	50
15713	(10-F)	2000
49994	(10-G)	375
49993	(10-H)	500
49995	(10-I)	140
41172	(10-J)	5000
40719	(10-K)	400

\*Does not include parts for mounting.

### No. 11 Resistance Coil

Similar to the No. 10 Type in design and method of mounting but with two non-inductive concentric wound coils. Package Assembly No. 203539 should be ordered separately for mounting parts which are the same as for No. 10 Type Resistance Coil.

### No. 11—Double Wound

*Coil Only Stock No.	Code	Concentric Wound Ohms Resistance	
		Inner	Outer
202252	(11-A)	1100	15000
202253	(11-B)	500	1000
202254	(11-C)	50	250
202255	(11-D)	100	500
15716	(11-E)	1000	10000
202256	(11-F)	200	600
202257	(11-G)	600	600
15717	(11-H)	50	50
202258	(11-I)	1500	1500
202259	(11-J)	1000	1500
202260	(11-K)	200	400
202261	(11-L)	25	1500
202262	(11-M)	50	1500
202263	(11-N)	1500	350
15718	(11-O)	200	1000
202264	(11-P)	300	1000
202265	(11-R)	240	240
201116	(11-S)	400	400
33756	(11-T)	10	1000
35035	(11-U)	500	10000
41652	(11-W)	250	250
40718	(11-X)	200	200
41173	(11-Y)	240	240, 140
41817	(11-Z)	15	600
41818	(11-AA)	1000	2000
41819	(11-AB)	1000	1000
42529	(11-AC)	500	350
42530	(11-AD)	750	10000
49972	(11-AE)	400	10000

\*Does not include parts for mounting.



No. 11 Resistance Coil

### Nos. 12, 13 and 14 Resistance Coils

These Resistance Coils are designed to mount similarly to the No. 500 Type Relay and are non-inductively wound.

### No. 12—Single Wound

Stock No.	Code	Winding Data—Ohms Res.
800493	(12-A)	320
800494	(12-B)	350
800495	(12-C)	500
800496	(12-D)	750
800497	(12-E)	1000
800498	(12-F)	1500
800499	(12-G)	2000
800500	(12-H)	200
800501	(12-I)	100
800502	(12-J)	50
800503	(12-K)	25
42827	(12-L)	4000

### No. 13—Double Wound

Stock No.	Code	Winding Data, Ohms Res.	
		Primary	Secondary
800504	(13-A)	50	50
800505	(13-B)	200	200
800506	(13-C)	240	240
800507	(13-D)	320	320
800508	(13-E)	400	400
800509	(13-F)	500	500
800510	(13-G)	1000	1000
800511	(13-H)	1500	2000
800512	(13-I)	10000	350
800513	(13-J)	10000	500
800514	(13-K)	10000	750
800515	(13-L)	10000	1000
800516	(13-M)	100	100
200010	(13-N)	18000	18000
202095	(13-O)	10000	10000
203565	(13-P)	500	800

### No. 14—Triple Wound

Stock No.	Code	Winding Data, Ohms Res.		
		Primary	Secondary	Tertiary
800517	(14-A)	240	240	140
200402	(14-B)	500	500	500

## GENERAL INDEX

A complete alphabetical index with cross references for all the products shown in this section or any of the other sections will be found in the center of this catalog.

**CONDENSERS—CAPACITORS**

Stromberg-Carlson Condensers are designed to withstand a working temperature of 140° Fahrenheit. This is a much higher temperature than that to which the majority of condensers are subjected in actual use and it is obtained by the thorough application of a special high melting point wax.

Tests are made for breakdown, capacitance and insulation resistance before assembly and these same tests are repeated in the completed assemblies before they are released. Insulation resistance of all types is 500 megohm-microfarads.

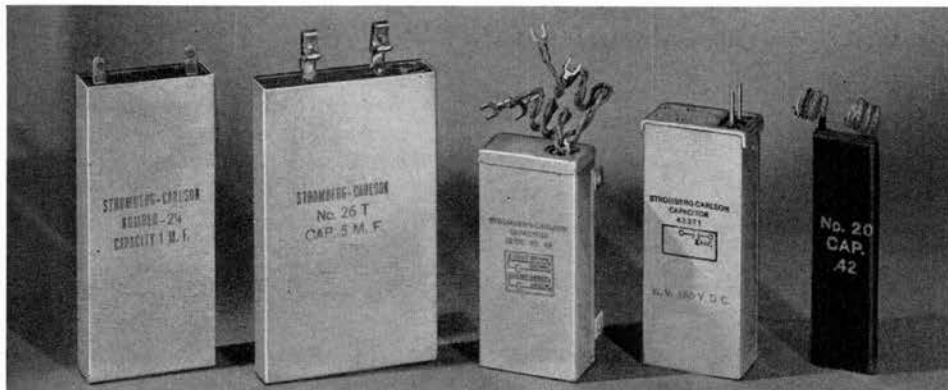

Style B                      Style D                      Style G                      Style J                      Style C

Standard ratings of Stromberg-Carlson Condensers which are in accordance with the National Electrical Manufacturer's Association standards, are as follows:

Voltage	Direct Current					Voltage	60 Cycles A.C.				
	Working	Test	Working	Test	Working		Test	Working	Test	Working	Test
Working	175	350	550	750	1000	Working	85	175	275	375	500
Test	350	700	1100	1500	2000	Test	175	350	550	750	1000

**Style A—Condenser Mounting Plate Type**

This is a discontinued switchboard type that mounted on condenser plates designed for this purpose.

These condensers are now used only for additions to switchboards in which they were originally specified as the present practice is to place condensers on the same type of mountings as relays.

Can dimensions: 4 3/4" x 1 7/8" x 31/32". Light finish.

Stock No.	Code	Capacity	Use
800518	(18-L)	1 mf.	Swbd.
803076	(19-L)	2 mf.	Swbd.
800528	(28-L)	3 1/2 mf.	Swbd.
800529	(29-L)	1 mf.; 500 N.I.	Swbd.
800530	(34-L)	3 mf.	Swbd.
800532	(35-L)	1 mf. and 2 mf.	Swbd.

**Style B—Unmounted Type**

Equipped with metal clips for mounting. Used in Booster Circuits of old type telephones and desk set boxes.

Stock No.	Code	Capacity	Use
800521	(21-L)	1 mf.	1155, 1157, 950, Tels. 1156, 1158, Desk Set Box
800522	(22-L)	2 mf.	Misc. Telephones
800524	(24-L)	1 mf.	948 Desk Set Box
800525	(25-L)	1 mf.	Telephone & Radio

**Can Dimensions**

21-L: 4 7/16 x 2 13/16 x 5/8"    24-L: 4 7/16 x 2 1/32 x 13/16"  
22-L: Same                      25-L: 3 5/8 x 2 1/32 x 13/16"

**Style C—Unmounted Type**

Has insulated wire terminals and black cloth cover.

Stock No.	Code	Capacity	Dimensions
800520	(20)	0.4 mf.	3 1/2" x 1" x 19/64"

Used with Nos. 6, 11 and 19 Handsets (Test Sets)

**Style D—Unmounted Type**

Has light finished metal case with Fahnestock clips. Dimensions: 4 7/16" x 2 13/16" x 5/8".

Stock No.	Code	Capacity	Use
800526	(26-T)	0.5 mf.	Sure-Ring (Receiver) Circuit Nos. 896, D-2843 Telephones Nos. 327, 1180 Desk Set Boxes

**Style E—Unmounted Type**

Metal case with light finish. Dimensions: 4 15/16" x 4 13/32" x 3/4". Mounts with metal clips.

Stock No.	Code	Capacity	Use
800527	(27-L)	5.0 mf.	Ringing Converters

**Style F—Unmounted Type**

Same as Style B but has 3 terminals. Used on old types of anti-side-tone wall telephones and desk set boxes.

Stock No.	Code	Capacity	Use
800534	(37)	1 mf. and 2 mf.	1155-A, 1157-A Telephones 1156-A, 1167 Desk Set Box

Can Dimensions: 4 7/16" x 2 13/16" x 5/8"

**Style G—Interior Handset Type**

Used in the base of desk and suspended type handset telephones and desk set boxes. Has metal case with light finish.

Dimensions: 3 11/32" x 1 9/16" x 7/8".

Stock No.	Code	Capacity	Use
33970 (48)		2.25 & 0.5 mf.	1222, 1223 Telephones; 1230 D.S. Box
34524 (49)		2.25 & 2 mf.	1233 Telephone
34917 (50)		2.25 mf.	1232 Telephone
800547 (51)		1 mf. & 500 Ohm N.I.	Converter (Rad. Elim.)

## CONDENSERS—CAPACITORS (Cont.)

### Present Style J—Relay Mounting Plate Type

Present Style J condensers, used in current switchboards and for all new work, are listed below under code numbers 55-67. These condensers mount the same as No. 200 Type Relays and will fit in No. 25 Relay Casings in which the casing proper is 4 inches long. Present Style J Condensers replace, but are not interchangeable with, former Style J (Code Nos. 38 to 44-A) which are used in old type Switchboards and mount in shorter relay casings. The terminal boards of these condensers are covered with hydrolene to reduce surface leakage in high humidities.

Can dimensions: 3 3/4" x 1.665" x 1"—Light Finish.

Stock No.	Code	Capacity
42370	(55)	1 mf.
42371	(56)	2 mf.
48346	(57)	3 mf.
42372	(58)	4 mf.
42373	(59)	1 mf.—1 mf.
42374	(60)	1 mf.—2 mf.
42375	(61)	2 mf.—2 mf.
42376	(62)	1 mf.—500 Ohms N.I.
49955	(63)	0.5 mf.—600 Ohms N.I.
200765	(64)	0.5 mf.
202466	(65)	.02 mf.—.02 mf.
202463	(66)	0.5 mf.—0.5 mf.
202464	(67)	1 mf.—0.5 mf.

All of the above are used with current types of switchboards.

### Former Style J Condensers Relay Mounting Plate Type

Condensers in the 38 to 44-A series are used only in switchboards in which this former style was originally installed. Like the new style J, these condensers mount the same as No. 200 Type Relays but the old style No. 19 Relay Casing is used in which the case proper is 3 3/4" long.

Can Dimensions: 3 13/32" x 1 11/16" x 31/32".

Stock No.	Code	Capacity
800535	(38-A)	1 mf.
800536	(39-A)	2 mf.
800537	(40-A)	4 mf.
800538	(41-A)	1 mf.—1 mf.
800539	(42-A)	1 mf.—2 mf.
802982	(43-A)	2 mf.—2 mf.
800541	(44-A)	1 mf.—500 Ohms N.I.

All of the above are used with old types of switchboards.

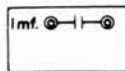

42370 (55)

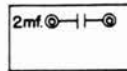

42371 (56)

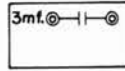

48346 (57)

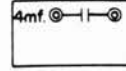

42372 (58)

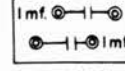

42373 (59)

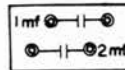

42374 (60)

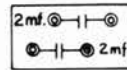

42375 (61)

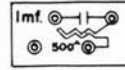

42376 (62)

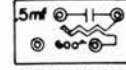

49955 (63)

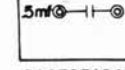

200765 (64)

### Miscellaneous Condensers

These are unmounted types designed for use in miscellaneous telephone and desk set boxes.

Stock No.	Capac. (mf.)	Dimensions	Use
25900	1-2	15/16" x 9/16" x 2 19/32"	1209 D.S. Box
28216	1-1.7	7/8" x 1 1/2" x 2 1/2"	1210-11 Tels.
28463	1-1.7	7/8" x 1 1/2" x 2 1/2"	1212 Telephone
			1217-18-19-20
			Chime D.S. Box
33231	2.25-1	7/8" x 1 1/2" x 3 3/8"	W-1218 D.S. Box
35149	1-1	1 1/16" x 19/32" x 2 1/8"	1191-92-95, 1202, 1215-1216 Tels.

### Special Condensers

The Stromberg-Carlson Condensers shown here are in general use for purposes specified. It is standard practice to mount terminal blocks on the covers but special condensers can be furnished with other types of terminals, containers or mounting arrangements.

Special Condensers are not carried in stock but different types can be made in quantity lots to specifications that will meet various requirements.

### No. 200595

#### Coil and Capacitor Assembly

The induction coil and capacitor comprising this assembly are embedded in a sealed plastic housing filled with hydrolene compound which protects the apparatus from moisture and excessive humidity.

The No. 200595 Induction Coil and Capacitor Assembly is shown in this section under Induction Coils.

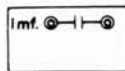
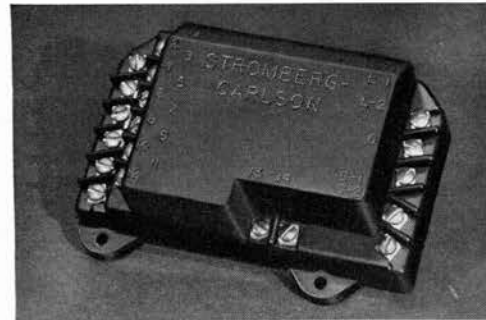

42370 (55)

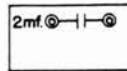

42371 (56)

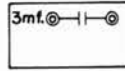

48346 (57)

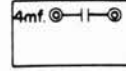

42372 (58)

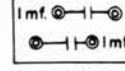

42373 (59)

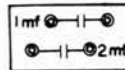

42374 (60)

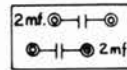

42375 (61)

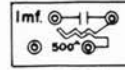

42376 (62)

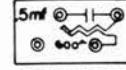

49955 (63)

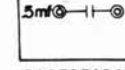

200765 (64)

### Condenser Mounting Plates

Condenser mounting plates are not furnished in present standard switchboards as it has become our regular practice to use the same type of plate on which relays are mounted. See Style J Condensers for relay mounting plate type. (Codes 55 to 64).

Style A Condensers which were designed for the Condenser mounting plates shown below are now used on old switchboards only where this type of mounting was originally specified.

Stock No.	Code	Used on	No. Cond. Mounted	Mtg. Centers
800548	(1)	Multiple Swbds.	16	18 7/8"
800551	(4)	Relay Bays	40	26"
800553	(6)	Relay Racks	24	25 1/2"
800554	(7)	Switchboards	20	20 3/8"
800555	(8)	No. 102 PBX Swbds.	16	17"
800556	(9)	PBX Swbds.	4	2 7/8"
800557	(10)	PBX Swbds.	1	Angle
800558	(11)	No. 13 Section	17	18 3/8"

STROMBERG-CARLSON

DESIGNATION STRIPS

No. 2 Type

These Designation Strips are used principally in multiple switchboards in connection with trunk jacks. They consist of a maple mounting block and a metal card holder with celluloid protector.

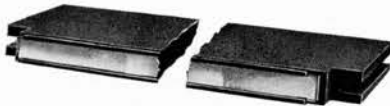

No. 2 Designation Strip

Stock No.	Code	Used With	Dimensions
800708	(2)	109 Jack	Face Length—10 15/32" Width—1/2" Mounting Centers—10 15/16" Jack Fastener—No. 15
800712	(6)	67 Jack	Face Length—6 43/64" Width—5/16" Mounting Centers—7 5/16" Jack Fastener—No. 12

No. 5 Type

Designation Strips of this type have metal card holders and celluloid protectors. They are arranged for screwing directly to the face of a switchboard, plugboard or keyshelf.



No. 5 Designation Strip

Stock No.	Code	Use	Length	Width	†Finish
800710	(5)	Plug Shelf	Specify 1/2"	1/2"	Pol. Nickel
800730	(24)	Keyboard	Specify 1/2"	1/2"	BLK. Japan
33764		Face, 120 Swbd.	10 23/64"	.373"	Brass

†Dull black finishes will be provided when necessary.

No. 14 Type

A type of Designation Strip consisting of a maple mounting block with a designation card, and celluloid protector—both held in place by three nickel plated screws. No. 14 is designed for use with eight panel multiple switchboards, and No. 16, which is similar to the No. 14, is used with six panel switchboards. Mounted with No. 17 Jack Fastener.



No. 14 Designation Strip

Stock No.	Code	Used on	Dimensions
800715	(14)	127 Jack	Face Length—7 15/32" Width—3/8" Mounting Centers—8 3/8"
800717	(16)	130 Jack	Face Length—10 1/8" Width—1/2" Mounting Centers—11 1/16"



No. 15 Designation Strip

No. 15 Type

These Designation Strips consist of a dull black finished metal holder and celluloid protector, mounted on maple mounting block. The No. 15 Designation Strip is used in 8 panel multiple switchboards, and the No. 17 Designation Strip is used in PBX Switchboards and 6 panel multiple switchboards. Requires No. 17 Jack Fastener.

Stock No.	Code	Used With	Dimensions
800716	(15)	127 Jack	Face Length—7 15/32" Width—5/16" Mounting Centers—8 3/8"
800718	(17)	130 Jack	Face Length—10 1/8" Width—1/2" Mounting Centers—11 1/16"
800728	(22)	Same as No. 15, except has slot at rear for sheet metal fire screen.	
800731	(25)	127 Jack	Face Length—7 15/32" Width—1/2" Mounting Centers—8 3/8"

No. 19 Type

This type consists of a metal mounting plate with a card designation strip, and celluloid protector strip, held in place by four nickel plated screws. Used on magneto Non-Multiple switchboards.

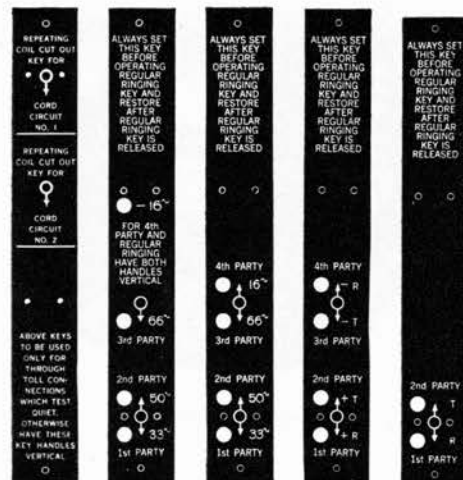

No. 19 No. 19-A No. 19-B No. 19-C No. 19-D

Stock No.	Code	Use	Dimensions
800719	(19)	Keyboard of No. 105 Switchboard designating cord circuit operation	Length—7 1/4" Width—1" Mtg. Centers—6 13/16"
800720	(19-A)	Keyboard of No. 105 Switchboard with Harmonic Master Key.	Same as No. 19
800721	(19-B)	Keyboard of No. 105 Switchboard with Harmonic Master Key.	Same as No. 19
800722	(19-C)	Keyboard of No. 105 Switchboard with Pulsating Master Key.	Same as No. 19
800723	(19-D)	Keyboard of No. 105 Switchboard with divided circuit Master Key.	Same as No. 19

## DESIGNATION STRIPS (Cont.)

### No. 20 Type

The No. 20 Type is shorter than the No. 19, but is of similar design. Used on PBX Switchboards to indicate the operation of the key cams.

Stock No.	Code	Use	Dimensions Length Width
800724	(20)	Manual PBX Trunk	5½" 1"
800725	(20-A)	Dial PBX Trunk	5½" 1"
800726	(20-B)	Magneto PBX Trunk	5½" 1"
800736	(30-A)	PBX—Cords, Jack Trunk	5½" 1"
800737	(30-B)	PBX—Cords, Jack Trunk	5½" 1"
800738	(31-A)	PBX—Cords, Jack Trunk	6½" 1"
47268	(32)	2 Pty. Ringing—No. 125 Swbd.	5½" 1⅞"
47269	(32-A)	4 Pty. with Hand Gen. No. 125 Swbd.	5½" 1"
47270	(32-B)	4 Pty. Harmonic—No. 125 Swbd.	5½" 1"
47271	(32-C)	5 Pty. and Reverse—No. 125 Swbd.	5½" 1⅞"
47272	(32-D)	5 Pty.—No. 125 Switchboard	5½" 1⅞"
201011	(33)	Cord cct. operation—PBX	6½" 1"

### No. 23 Type

These designations consist of a dull black finished holder and a celluloid protector. Made to fasten to wood surfaces with 3 No. 128 Wood Screws. Used on No. 115 Lamp Signal Magneto Switchboards.

Stock No.	Code	Used	Dimensions Length Width
800729	(23)	115 Swbd.	10⅞" ⅜"

### No. 26 Type

These designations consist of a dull black finished holder with a semi-transparent protector. They mount directly in front of No. 121 Lamp Sockets so that only pin points of light show through for trunk signal service. Push fit in face of lamp socket.

Stock No.	Code	Used with 121 L.S.	Dimensions Length Width
800732	(26)	20 per	7½" 31/64"
800733	(27)	10 per	10⅞" 31/64"
800734	(28)	20 per	10⅞" 31/64"
800735	(29)	10 per	7 15/32" 31/64"

## DIALS

For Stromberg-Carlson Dials and Dial Parts, designed to fit not only Stromberg-Carlson Telephone instruments, but those of any other American make, see Section A of this catalog. A complete description and instructions for maintenance are also prepared in an attractive booklet which is available upon request or from your Stromberg-Carlson representative.



Stromberg-Carlson Dial

### DIAL MOUNTINGS

#### Switchboard Type

For mounting a Stromberg-Carlson Dial on switchboards already in the field, at the time of adding dial trunks, specify No. 202527 (1-E) Dial Mounting and Package Assembly No. 203761 which contains the necessary screws for attaching the mounting to the board.

#### Suspended Telephone Type

For mounting a Stromberg-Carlson Dial on suspended type telephones already in the field, specify No. 200820 (143-A) Dial Mounting.

NOTE: The 143-A Dial Mounting will take any of the Stromberg-Carlson Type E Dials but not Type F.

## DISTRIBUTING BARS



No. 1-A Distributing Bar



No. 3 Type Distributing Bar

### No. 1-A Type

A single point distributing bar with terminal lugs for front and back connections. Used chiefly to terminate power leads in PBX Switchboards.

Stock No.	Code	Points	Used on
800751	(1-A)	1	Terminal boards of PBX Switchboard to connect with battery supply.

### No. 3 Type

This distributing bar is used for connecting a given number of wires to a common source of current or to a common ground. Provides convenient means of opening circuits for testing purposes. Consists of a drawn brass bar, screws, and tinned terminal lug. Used on switchboard terminal boards.

Stock No.	Code	Points	Length
800741	(3)	4	2⅞"
800743	(5)	6	3⅞"
800745	(7)	8	4⅞"
800746	(8)	10	5⅞"
800749	(11)	16	8⅞"
800750	(12)	20	10⅞"

STROMBERG-CARLSON

LINE AND CLEAR-OUT DROPS

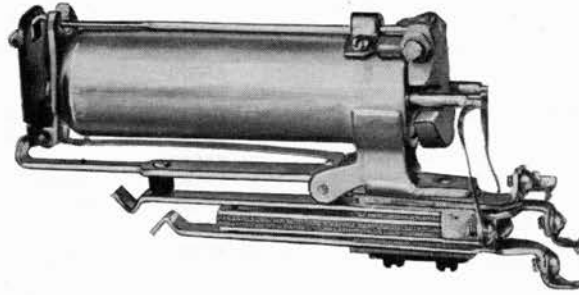

No. 18 Type Drop

**Nos. 18 and 23 Type Line Drops**

These line signals consisting of a combined plug-restoring drop and jack unit are used in present Stromberg-Carlson magneto switchboards such as the No. 125 with floor cabinet in which the drops are mounted in groups of ten and the No. 126 Wall Type which is arranged for mounting in groups of five.

The No. 18 Type is equipped with contacts for regular night alarm service only but provision is made for adding the necessary contact assembly for code alarm service in case this feature is required at some future time.

The No. 23 Type equipped with separate contacts for both regular night alarm and code alarm signals. In other respects these two types use the same parts for both the drop and jack assemblies and both are designed to take the No. 56-X Two-Conductor Plug.

The No. 18 and 23 Type Drops are of unit construction, consisting of double cut-off jacks with long, rugged springs combined with a complete drop signal having a shutter that is automatically restored when the operator plugs into the jack. The design permits easy removal of drop coils, jacks and other assembly parts which is a desirable feature from the standpoint of maintenance. The construction throughout is simple and durable and this, together with the use of properly selected materials, assures successful resistance against the constant wear-and-tear to which all line signals are subjected.

**Nos. 18 and 23 Type Line Drops  
Less Mounting Plates**

Stock No.	Code	Resistance Ohms	Type Alarm	Plug Used	No. of Drops per strip
801788	(18-A)	200	Regular	No. 56-X	10
801789	(18-B)	500	Regular	No. 56-X	10 or 5
801790	(18-C)	600	Regular	No. 56-X	10
*49608	(18-D)	100-100	Regular	No. 56-X	10
801798	(23-B)	500	Reg. & Code	No. 56-X	10
	(24-B)	500	Reg. & Code	No. 65-X	10

\*For push button signalling on metallic lines.

Nos. 18 and 23 Line Drops, when furnished without mountings, do not include the following parts which are furnished only when ordered with fully equipped mounting plates:

Stock No.	Description
27271	Metal Sleeve (Jack)
27188	Insulating Sleeve
27297	Washer (Sleeve)
37196	Spacer
37469	Bushing

**Nos. 18 and 23 Type Line Drops  
With Mounting Plates**

Nos. 18 and 23 Type Drops on fully equipped mounting plates of ten each will be carried in stock for additions to No. 125 Switchboards that are now in service.

Stock No.	Description
40134	10—No. 801789 (18-B) Drops (500 Ohms) mounted on 1—No. 37197 (147) Drop Mounting Plate
49612	10—No. 49608 (18-D) Drops (100-100 Ohms) mounted on 1—No. 37197 (147) Drop Mounting Plate
40133	10—No. 801798 (23-B) Drops (500 Ohms) mounted on 1—No. 37197 (147) Drop Mounting Plate

NOTE: In ordering drops required numbering should be always be specified.



10 No. 18 Drops on No. 147 Drop Mounting Plate

**No. 21 Type Clear-Out (Ring-Off) Drop**

The No. 21 Clear-Out Signal is a drop unit only of the same construction as the drop used in the combined drop and jack line signals. These drops are manually restored and are used as clear-out signals in the No. 125 and No. 126 Switchboards.

Stock No.	Code	Resistance	Description
801793	(21-A)	200 Ohms	Clear-Out Signal (Less Jack)
801794	(21-B)	500 Ohms	Clear-Out Signal (Less Jack)
801795	(21-C)	600 Ohms	Clear-Out Signal (Less Jack)
*49609	(21-D)	100-100 Ohms	Clear-Out Signal (Less Jack)

\*For push button signalling on metallic lines.

**Coils for Nos. 18, 21 and 23 Drops  
Standard Types of Complete Drops**

No. 18 Type Line signal (Regular alarm only) No. 56 Plug  
No. 23 Type Line signal (Regular and code alarm) No. 56 Plug  
No. 21 Type Clear-out signal (No jack) No Plug

Stock No.	Resistance	Use
27186 Coil only	200 Ohms	Nos. 18-A, 21-A Drops
49142 Coil only	100-100 Ohms	No. 21-D Drop
49143 Coil only	100-100 Ohms	No. 18-D Drop
35427 Coil only	500 Ohms	Nos. 18-B, 21-B, 23-B, 24-B Drops
35428 Coil only	600 Ohms	Nos. 18-C, 21-C Drops

NOTE: No. 200429 Impregnated 500 Ohm Coils are used with No. 18-B and 21-B line and clear-out drops in the No. 126 Wall Type Switchboard.

## COMBINED DROP AND JACKS UNITS

### Parts of Nos. 18 and 23 Type Drops (Less Coils)

Stock No.	Description	Use	Stock No.	Description	Use
3937	Screw— (See No. 503883)	Coil retaining screw	27300	Screw	Used with No. 27163 Saddle
8612	Washers (2)	Used with bracket screws	(a) 27301	Pin	Used with No. 27173 Spring
9681	Connectors (4)	Jack Springs	27347	Number plate	Shutter (specify number)
10552	Screws— (See No. 501003)	Used with connectors	33972	Shutter assembly	Drop assembly
(a) 13301	Plate	Spring pileup (Top)	(a) 34883	Stud	Jack assembly
(a) 16775	Plate	Spring pileup (Bottom)	(b) 37196	Spacer	Used with No. 37468 Bracket
(a) 24975	Insulation (5)	Spring pileup	(a) 37463	Insulation	See No. 202039
(a) 25990	Screws (2)	Spring pileup	37465	Rod assembled	Drop Coil
27163	Saddle	Drop shell	(a) 37467	Shell	Used with No. 37465 Rod
(a) 27173	Spring	Shutter restoring	(a) 37468	Bracket	Drop assembly
(a) 27175	Separator	Spring pileup	37471	Armature assembly	(Code alarm) consisting of—
(a) 27176	Terminal	Used with No. 27194 Spring	(a) 37523	Contact assembly	1 No. 37465 Rod, 1 No. 13064 Spring 1 No. 5723 Screw
(a) 27178	Insulations (2)	Spring pileup	(a) 49768	Screws (2)	Used with No. 37468 Bracket
27179	Screws (2)	Armature	(a) 49769	Bushings (2)	Used with No. 49768 Screws
27180	Nuts (2)	Armature	202039	Rod assembly	Code alarm
(b) 27188	Insulating sleeve	Jack assembly	501003	Screws (6)	Used with No. 9681 Connectors
(a) 27191	Spring assembly	Ring conductor	503883	Screw	Coil retaining screw
(a) 27192	Spring assembly	Tip conductor			
(a) 27193	Spring assemblies (2)	Inner contacts			
(a) 27194	Spring assembly	Regular night alarm			
(b) 27271	Jack (Metal bushing)	Drop and Jack unit			
27272	Connectors (2)	Terminals			
(b) 27297	Washer	Jack sleeve			
(a) 27298	Bushings (2)	Used with No. 25990 Screws			
27299	Screws (2)	Drop shutter			
27300	Screws (2)	Used with No. 37468 Bracket			

(a) A basic assembly of these parts may be ordered under Stock No. 200578 which includes both regular and code alarm contacts but does not include jack nor associated parts.  
 (b) These parts are assembled with the strip on which the drops are mounted. See "Drop Mountings".

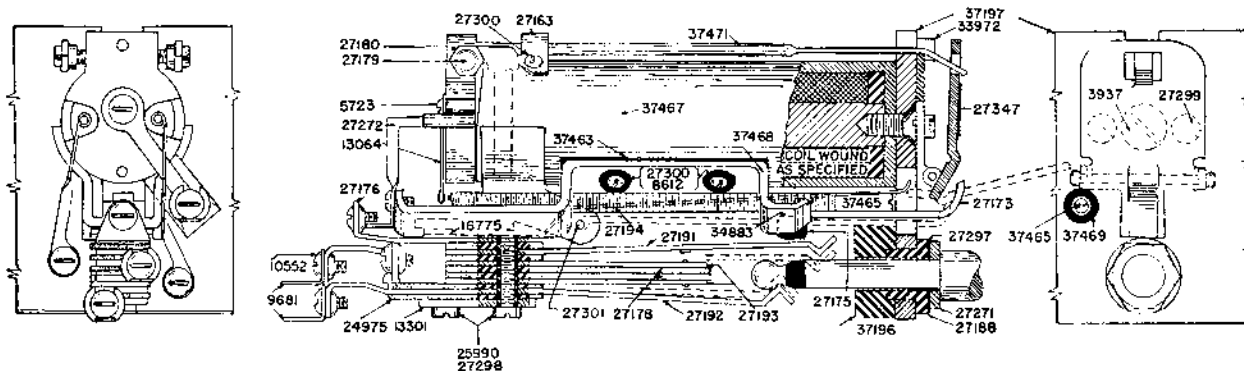

Parts of Nos. 18 and 23 Type Drops

### Drop Mounting Plates

Stock No.	Code	Description	Use
*37197	(147)	Mounts 10 No. 18 or 23 Line Drops	No. 125 Swbd.
37198	(148)	Mounts 10 No. 21 Clear-Out Drops	No. 125 Swbd.
39860	(149)	Mounts 10 No. 24 Line Drops	No. 106 Swbd.
200435	—	Mounts 5 No. 18 or 23 Line Drops	No. 126 Swbd.

\*No. 37197 (147) Drop Mounting Plate is assembled with the following parts:

- 10 No. 27271 Metal Bushings (Jack)
- 10 No. 27188 Insulating Sleeves
- 10 No. 27297 Washers(sleeve)
- 1 No. 37196 Spacer
- 10 No. 37468 Bushings

### Drop Blanks

Stock No.	Code	Type Drop	No. of Drops Covered	Used
803002	(42)	18, 23	10	No. 125 Magneto Switchboard.
200476	—	18, 23	5	No. 126 Magneto Switchboard.
802997	(41)	23	1	Nos. 125, 126 Magneto Swbds.
803470	(43)	18	1	Nos. 125, 126 Magneto Swbds.

### Drop Blanks—Steel

Stock No.	Code	Fills the space of—
800017	(33)	1 No. 11 Drop
800018	(34)	5 No. 11 Drops

FORMER DROPS

No. 11 Type Combined Drops and Jacks

This is a line signal used on replaced magneto switchboards such as the No. 105 and A-11741 types which have been superceded respectively by the No. 125 and No. 126.

The No. 11 Unit consists of a combined Jack and complete drop that mounts in strips of five. This drop is used for replacements only as all magneto boards that are now standard are equipped with No. 18 or No. 23 Type Line Drops.

Single drop measures 4 7/8" x 1 3/32" x 1 7/16". The No. 140 drop strip mounts 5 drops: 7 7/64" x 1 7/16".

The No. 12 type drop—less jack—is the clearing-out signal associated with the No. 11 type line drop. On present types of magneto boards the No. 21 type clearing-out is used in place of the No. 12.

Special Coil

No. 28442 is a double wound balanced drop coil that is interchangeable with the standard single wound coil of the No. 11 Drop. This coil reduces power line inductive interference and is used on lines that have push button telephones for ringing central.



No. 11 Drop on No. 140 Drop Mounting

Stock No.	Code	Use	Resistance
801771	(11-A)	Line Signal in former Magneto Switchboards	500 Ohms
801773	(11-F)	Same as 11-A	1000 Ohms
801775	(12-A)	Clear-Out Signal (has no jack)	500 Ohms
801777	(12-F)	Same as 12-A	1000 Ohms
801781	(14-A)	Same as 12-A	500 x 500 Ohms
801782	(16-A)	Same as 11-A except takes No. 53 Plug	500 Ohms
801784	(16-F)	Same as 16-A	1000 Ohms
801785	(17-A*)	Takes No. 53 Plug	500 Ohms
801787	(17-F*)	Takes No. 53 Plug	1000 Ohms

\*In these drops the jack sleeve is terminated for busy test on multiple or cord circuit functions.

Parts of Nos. 11, 16, 17 Line Drops

Nos. 12 and 14 Clear-Out Drops

Stock No.	Description	Used on Drop Nos.	Stock No.	Description	Used on Drop Nos.
2525	Screw	11, 12, 14, 16, 17	9655	Spring Assembly (contact)	11, 16, 17
2667	Screw	11, 12, 14, 16, 17	9657	Insulations (short spring) 4	11, 16, 17
2908	Washers (2)	11, 12, 14, 16, 17	9660	Bushing (Jack)	11
4785	Washer	11, 16, 17	9663	Clamp Plate	11, 16, 17
5487	Washer	11, 12, 14, 16, 17	9664	Connector	11, 16, 17
6613	Terminal	11	9665	Connector	11, 16, 17
6703	Screw	11, 16, 17	9668	Bushings (2) Spring	11, 16, 17
8067	Screw	11, 12, 14, 16, 17	9681	Connectors (2)	11, 16, 17
9025	Bushing	11, 16, 17	10552	Screws (501003) 4—RHBM	11, 16, 17
9027	Bushing (2) Frame	11, 12, 14, 16, 17	12258	Coil—500 Ohms	11-A, 12-A, 16-A, 17-A
9036	Pin	11, 12, 14, 16, 17	12259	Coil—1000 Ohms	11-F, 12-F, 16-F, 17-F
9038	Pin	11, 12, 14, 16, 17	12260	Coil—500-500 Ohms	14-A
9045	Bushing	11, 16, 17	13064	Spring (Armature)	11, 12, 14, 16, 17
9066	Screws (2)	11, 12, 14, 16, 17	13244	Bushing (Sleeve)	16, 17
9634	Frame assembled	11, 12, 14, 16, 17	13531	Rod Assembly	11, 12, 14, 16, 17
9638	Insulation	11, 12, 14, 16, 17	13532	Shell Assembly	11, 12, 14, 16, 17
9639	Armature	11, 12, 14, 16, 17	13534	Number Plate	11, 12, 14, 16, 17
9647	Spring (Jack)	11, 16, 17	13535	Protector	11, 12, 14, 16, 17
9649	Spring (Jack)	11, 16, 17	15810	Button	11, 16, 17
9651	Spring Assembly (contact)	11, 16, 17	17016	Shutter	11, 12, 14, 16, 17
9653	Insulations (Long spring) 2	11, 16, 17	17017	Frame	11, 16, 17

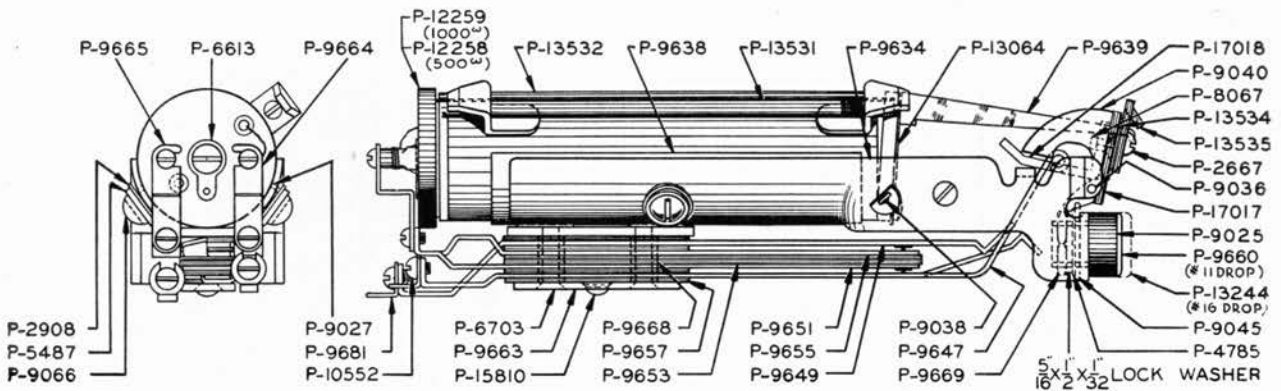

Line Drawing Showing Piece Parts of the No. 11 Drop

## EXTENSION BELLS

See Supply Catalogue for No. 53 Loud Ringing Extension Bell.

## FOOT RAILS AND FOOT RAIL BRACKETS

Foot rails with foot rail brackets are generally used with switchboards having keyboard heights greater than 31 inches. Switchboards with lesser heights permit the use of operators' chairs low enough to allow the operator to rest her feet comfortably on the floor.

Iron pipe foot rails with black finish and cast iron brackets to match are standard for the equipment here shown.

### No. 11 Bracket



No. 11 Bracket and No. 13566 Cap

The No. 11 Bracket is used with switchboards having high keyboards. It mounts directly on the floor with four No. 12 x 2" F.H.I.W. Screws and takes a two inch iron pipe foot rail that

is not furnished unless specified. Dimensions of base: Length—6½", Width—2½", Height to center of rail—6". Uses No. 13566 caps to fill openings at ends of foot rail.

Stock No.	Code	Used With	Finish
13565	(11)	Central Office Switchboards	Black Enamel

### No. 12 Foot Rail Assembly

A two inch iron pipe foot rail is furnished with two of these cast iron brackets which mount on the end panels of switchboard sections. Dimensions of bracket: Length—6", Width—1½". Uses—13566 Caps to fit ends of foot rails.

Stock No.	Code	Used With	Finish
800763	(12)	No. 3 Unit Type Swbds.	Black Enamel



No. 12 Bracket

### Parts of No. 12 Foot Rail Assembly

13700 Foot Rail Only	No. 3 Section	Black Enamel
13566 Cap	No. 11 or 12 Bracket	Black Enamel

## FUSES

### Indicator Alarm Type

A flat spring on the reverse side of the fuse is connected by fuse wire to a coiled spring on the opposite side. When the fuse is operated this coiled spring causes a glass bead to appear in a prominent position as a visible indication of the blown fuse.

This fuse may also be made to connect with an alarm circuit which operates when the fuse wire is broken.

### 250 Volt (Enclosed)

Stock No.	Overall Length	Operates On	Stock No.	Overall Length	Operates On
41036	2"	3 Amp.	41042	2"	30 Amp.
41037	2"	6 Amp.	41043	3"	35 Amp.
41038	2"	10 Amp.	41044	3"	40 Amp.
41039	2"	15 Amp.	41045	3"	45 Amp.
41040	2"	20 Amp.	41046	3"	50 Amp.
41041	2"	25 Amp.	41047	3"	60 Amp.

### GONGS

The following gongs are used with Stromberg-Carlson Ringers:

Stock No.	Size	Finish	No. of Telephone
*28569	1¾"	Brass	1210, 1211, 1212, 1222, 1223, 1242, 1243, 1247, 1248, 1258 Handset Tels.
*28570	1¾"	Brass	1260, 1268 Desk Set Boxes
9888	2"	Brass	903, 904, 965, 1122, 1163-I-C Tels. and 1192 Handset Telephones
12047	2½"	Black	896, 1155, 1157, D-2843 Tels. 327, 1156, 1158, 1167, 1180 and 1230 Desk Set Boxes.
24604	3 5/16"	Black	1191 Telephone, 1209 Desk Set Box
8437	4"	Brass	890, 950 Iron-Clad Telephones.

\*28569 and 28570 are used in pairs. The material is of different thickness to produce a two-tone effect.

### Protection Fuses

These are link-type fuses with coppered terminals that are used principally for protecting power circuits.

Stock No.	Code	Amp. Rating	Screw Centers	Replaces	Used on
801560	(1)	3	1"	G-179	Connecting Racks
801561	(2)	3	1 1/16"	G-736	Power Boards
801562	(3)	10	1"	G-174	Relay Racks

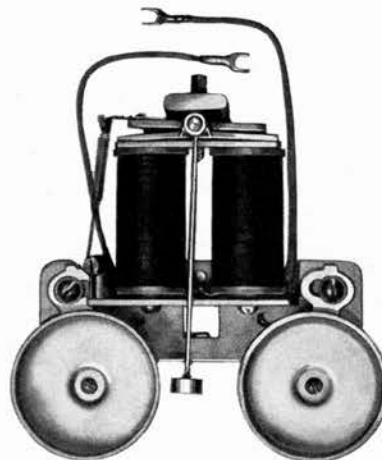

Gongs with typical Stromberg-Carlson Ringer

HAND GENERATORS

No. 64 Streamlined Type

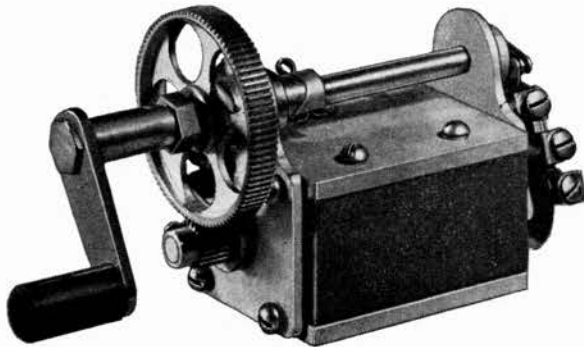

No. 64 Alnico Hand Generator

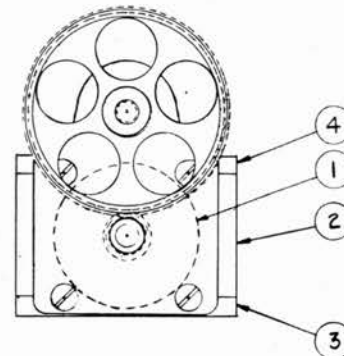

The No. 64 is a compact Alnico magnet generator used in our streamlined magneto telephones and while occupying a much smaller space it is fully as powerful as the bulky, old style 5-bar generator.

The No. 64 is an adaptation of the generator that has been used over a period of years for government requirements and has proved entirely dependable under every possible condition that can be encountered in actual service operation.

This generator furnishes a surplus of ringing current, with ample voltage at all loads. Precision design and accurately made assembly parts have produced a smooth motion that assures long life and economical service.

Stock No.	Code	Description	Use
201678	(64)	Alnico Generator	No. 1248, 1258 Telephones No. 1268 Mag. Desk Set Box

Assembly Parts—No. 64 Generator

Drawing Item No.	Stock No.	Description
	201679	Armature assembly
	201792	Crank assembled
2	201690	Magnets
3	201691	Field pole plate (Bottom)
4	201692	Field pole plate (Top)
5	201693	Bearing plate
6	201694	Bearing plate
7	201695	Generator Shaft assembly
9	201697	Cam (over shaft)
10	201698	Large Gear
11	201699	Pinion (Small Gear)
12	201700	Collar (over large gear sleeve)
13	201701	Spiral spring (Next to large gear)
14	201702	Spring retainer (Hex nut)
17	201705	Spring (Next to Armature)
18	201706	Contact Spring Assembly (Shunt)
19	201707	Contact Spring Assembly (Shunt)
20	201709	Contact Spring Assembly (Shunt)
21	201711	Screw Plate
22	201713	Insulations (4) Springs
23	23392	Set Screw (Collar)
24	245	Cotter pin (Cam)
25	501853	Screw (Pinion to shaft)
26	503623	Terminal Screws (3)
27	504153	Screws (2) Screw plate
28	505353	Screws (8) Bearing plates
29	65346	Screws (4) Top field plate
31	526132	Split lock washer (12) Bearing and top plates
32	201708	Thrust washers (As required)

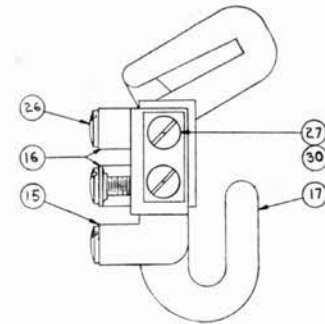
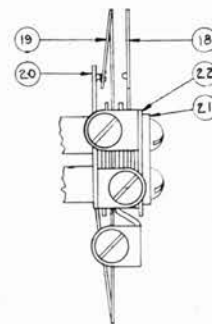
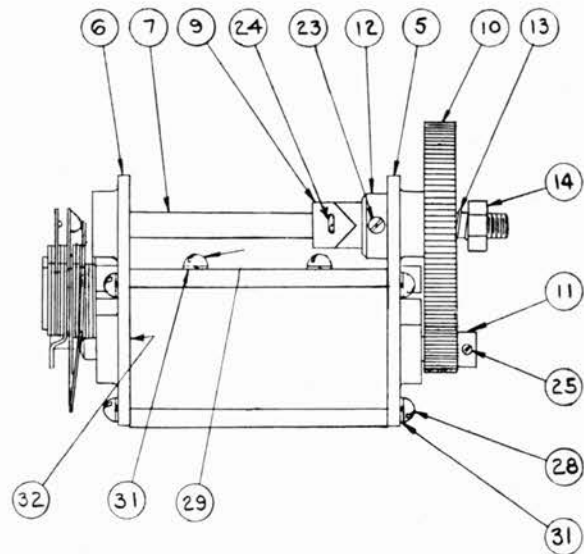

Specify 201678 (64) Alnico Generator and adapter for replacement of discontinued No. 38 Type (5-bar) on the following types of former magneto sets: D-2843, D-2844, 896 Wall Telephones and 1180 Desk Set Box.

## HAND GENERATORS (Cont.)

### Large Type—No. 38

The No. 38 Generator, with 5 horse shoe type magnets, has been replaced by the smaller and more efficient No. 64 Generator with Alnico magnets for both telephones and switchboard use.

In the case of replaced magneto telephones and desk set boxes the old style No. 38 Generator may be replaced with the No. 64 by the use of adapter spacers which make the mountings interchangeable.

The replaced telephones using the No. 38 Generator include No. 896 and D-2843 Magneto Wall Sets, No. 1180 and 327 Desk Set Boxes.

Stock No.	Code	Description	Use
800764	(38)	Generator—5 bar	Older Types of telephones and desk set boxes.

### No. 53 Generator—3 Bar Discontinued

#### No. 62-A Hand Generator

This is a large type five-bar generator especially designed for the No. 890 Type iron-clad magneto telephone. Unlike types used with other magneto telephones, this generator is equipped with a clutch that permits permanent mounting in a sealed compartment. See No. 890 Type Telephone in Magneto Section.

Stock No.	Code	Description	Use
800769	(62-A)	Generator No. 890	Iron-Clad Telephone

### Crank Shafts for Switchboard Generators

The following generator crank shafts are designed for switchboard use:

Stock No.	Code	Length	Generator	Swbd. No.
800774	(2)	18 1/2"	53	102
800775	(3)	16"	38	105
*33759	—	15 11/16"	53	120
37258	—	16"	38	125

\*On No. 120 Switchboards, No. 33760 Oxidized bronze crank handle is used with No. 33759 crank shaft in place of standard No. 11730 steel crank handle.

### No. 963 Ironclad Generator

This is a 5 bar hand generator mounted in a corrosion proof iron housing with a gasket-sealed door. It is designed for bell signaling systems underground or in locations exposed to the elements.

Stock No.	Code	Description	Use
802047	(963)	Ironclad Hand Generator	Low voltage signal systems.

### Parts of No. 38, 53, 55, 62-A Types

Stock No.	Code	Description	Generator
800764	(38)	Generator (5-bar bridging)	
800769	(62-A)	Generator (5-bar bridging)	
No. 53 Generator (3-bar bridging) Parts only available.			
No. 55 Generator (3-bar pulsating) Parts only available.			
Stock No.	Description	Generator	
11039	Armature (5-bar bridging)	38, 62-A	
8058	Armature (3-bar bridging)	53	
11395	Armature (3-bar pulsating)	55	
3556	Magnet (Horse shoe type)	38, 62-A, 53, 55	
6013	Shunt Spring Asembled	38, 62-A, 53	
3577	Shaft	38	
11578	Shaft	62-A	
3575	Shaft	53, 55	
4444	Large Gear	38, 62-A, 53, 55	
278	Collar—Attached to large gear	38, 62-A, 53, 55	
266	Collar (On shaft next to crank arm)	38, 53, 55	
265	Spring ([spiral] Gear end of shaft)	38, 62-A, 53, 55	
11574	Disc ([Two-posts] Engaged by crank)	62-A	
11571	Block (Engages disc)	62-A	
3709	Screw (Holds block)	62-A	
3498	Pinion (small gear)	38, 62-A, 53, 55	
4133	Spring (In pinion recess)	38, 62-A, 53, 55	
3497	Stop (Covers pinion recess)	38, 62-A, 53, 55	
11674	Hex. head Screw (Attaches stop)	38, 62-A, 53, 55	
11673	Washer (Under hex. head screw)	38, 62-A, 53, 55	
11730	Crank Handle (Steel)	38, 53, 55	
11576	Crank Handle (Steel)	62-A	
33760	Crank Handle (Ox. Bronze) No. 120 Swbd.	53	
33761	Crank Handle (Ox. Bronze) No. 121 Swbd.	53	



No. 963 Generator

## HOLLY STRIPS

White Holly Strips mount between jack strips. Used for segregating multiple jacks in banks of 100.

Stock No.	Code	Used With	Dimensions	Material
6984	(3)	109 Type Jacks	Length, 10 15/32" Width—1/2" Thickness, 1/16" Jack Mounting Cntrs, 10 15/16"	White Holly with Lacquered Edges
8940	(13)	No. 67 Jack	Length, 6 21/32" Width—1/2" Thickness, 1/32" Jack Mounting Cntrs, 7 15/16"	White Opaque Celluloid



No. 3 Holly Strip

NOTE: Nos. 13 and 15 mount with 3 No. 22 x 1/4" R.H. Brass Escutcheon Pins.

Stock No.	Code	Used With	Dimensions	Material
13116	(15)	No. 127 Jack	Length, 7 19/32" Width—3/8" Thickness, 1/16" Jack Mounting Centers, 8 3/8"	White Opaque Celluloid
13444	(16)	No. 130 Jack	Length, 10 3/8" Width—1/2" Thickness, 1/16" Jack Mounting Cntrs, 11 1/16"	White Holly with Lacquered Edges



No. 16 Holly Strip

**HOOKSWITCHES AND HOOKS**

**No. 41 Type Hookswitch**



No. 41 Type Hookswitch

This assembly consists of a removable hook for long hand receiver, stamped steel frame and springs of nickel silver. Two types of spring combinations are available. The finish is black.

Stock No.	Code	Description	Use
801956	(41-B)	Hookswitch	Common battery and magneto wall sets
801957	(41-G)	Hookswitch	Intercommunicating wall sets

The No. 41-B and No. 41-G assemblies are the same with the exception of the spring combinations.



No. 41-B

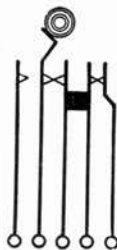

No. 41-G

Spring Combinations

**No. 42 Type Hookswitch**

The No. 42 Hookswitch was designed for old style hookswitch boxes and suspended type combination phone sets that have not been made since 1928. The switch box in these sets was fitted with a one-piece hook from which a No. 10 Combination phone with a fluted rubber handle was suspended by a metal eyelet attached to the receiver.

Code No.	Use
(42-B)	No. 10-C (Common Battery) and No. 10-L (Magneto) Combination phones with No. 19 and No. 36 Hookswitch Boxes.
(42-G)	No. 30, 31, 32 Hookswitch Boxes in old inter-communicating systems.

**Hookswitches for Handset and Desk Telephones**

These should be ordered by giving the type of telephone with which they are used. for example, hookswitch (spring assembly) for No. 1222 or 1243 Handset Telephone or No. 1182 Desk Stand.

**Hookswitches Less Hooks**

Stock No.	Used with Hookswitch No.	Used on Wall Sets Magneto	Used on Wall Sets Common Battery
13824	41-B	896, D-2843	1155, 1157
13825	41-G		*903, 1163

\*Selective Talking, Selective Ringing I.C. Systems  
 Used on Suspended Telephone Sets  
 Common Battery Handset Type  
 19136 1201 and 1234  
 34522 1232 and 1233

**Hooks Only**

Stock No.	Hookswitch Used (Less Hook)
8741	Hook No. 13824, 13825 on long hand receivers
27677	Hook No. 13824 on hand set telephones
24093	Hook No. 19136, 34522 on handset telephones.

**Parts of Complete Hookswitch for Ironclad Telephones**

Stock No.	Description
10818	Hook Assembly
8457	Spring Assembly
8465	Plunger

See "Telephone" Section, Ironclad Telephones.

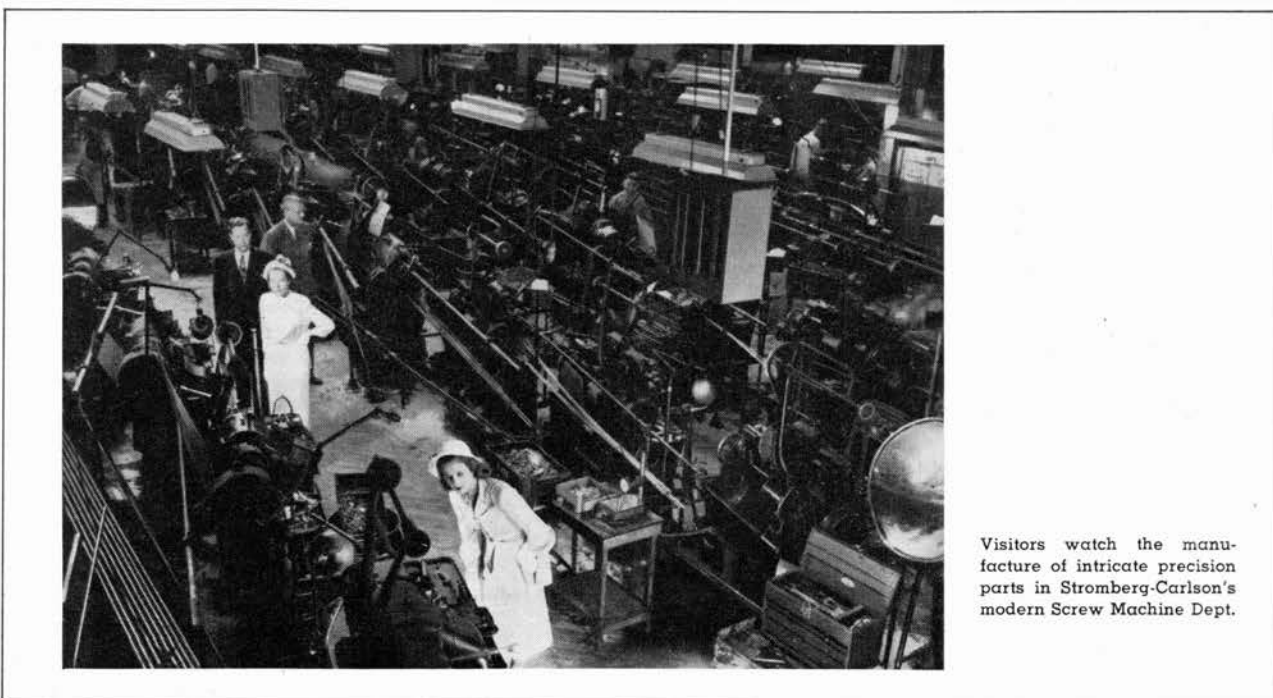

Visitors watch the manufacture of intricate precision parts in Stromberg-Carlson's modern Screw Machine Dept.

**STROMBERG-CARLSON**

## JACKS

The essentials of a good jack are long life and reliable spring pressure that insures low contact resistance in transmission circuits. Stromberg-Carlson Jacks possess these qualities.

Whether jacks are furnished individually or in strips, they are equipped with the best nickel-silver springs and are insulated with phenolic fibre of a quality that will not give under pressure. This provides firm spring assemblies which will keep their original adjustment.

When jacks are mounted on strips they are assembled in groups of five, ten or twenty; and are equipped with dull finished hard rubber facestrips, either plain, with white line divisions, or drilled for party line indicators. State the type and code number of the mountings when ordering jacks in strips. Jacks fasteners are not included, but must be ordered separately.

### OPERATOR'S AND INDIVIDUAL JACKS

#### Operator's Jacks



No. 93 Jack Assembly

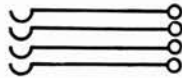

Spring Combination, 93 Jack

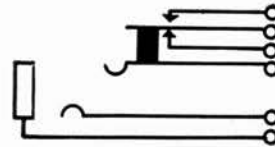

No. 140 Jack Spring Combination

Stock No.	Code	Description
801082	(93)	Standard operator's cut-in jack for all multiple and non-multiple switchboards. Mounts below key shelf on lock rail. Shape—Oblong Face. Finish—Black Enamel. Takes either No. 23 or newer type No. 66 four-point plug. All four points are used with operator's sets having breast plate transmitters but only two points are required for operator's sets having suspended type transmitters.
801083	(93-B)	Similar to 93 except that it has a one break contact.

#### Individual Jacks



No. 140 Jack Assembly

Stock No.	Code	Description
49907	(140)	Used as a Transfer Jack in three position Magneto Switchboards to transfer calls from one position to another. Shape—Hexagonal Face. Finish—Nickel Polished. Length—3 31/64". Face Dimensions—1/2". Mounting Centers—Horizontal—15/16". Vertical—3/4". Plug required—No. 42 two conductor, No. 57 two conductor, or No. 55 three conductor plug.

NOTE—No. 140 Jack may be furnished either individually mounted or 5 per strip on No. 84 or No. 85 Mountings. The No. 84 Mounting is drilled for both a jack and a No. 121 Lamp Socket. The No. 85 Mounting is drilled for the jack only. These mountings will mount in place of a strip of 5 drops.

Stock No.	Code	Description
200707	(140)	Jacks, No. 84 Mounting—5 per strip, with 121 Lamp Sockets.
801177	(140)	Jacks, No. 85 Mounting—5 per strip.

#### Individual Jacks for PBX and Magneto Switchboards

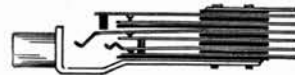

No. 158 and No. 159 Spring Combination



No. 160 Spring Combination

Stock No.	Code	Description
802598	(158)	An individual jack of the same general construction as the No. 144. Used in the 120 PBX Switchboards. Takes No. 53 or No. 65 Plug.
802599	(159)	Similar spring combination and construction to No. 158. Used in No. 115 Lamp Signal Magneto Switchboards. Takes No. 61 Plug.
802600	(160)	An individual double cut-off line jack used in No. 120 PBX Switchboards. Oxidized bronze finish. Takes No. 53 or No. 65, three conductor Plug.



No. 161 Spring Combination

Stock No.	Code	Description
802601	(161)	An individual jack with tip, ring and sleeve conductors and local break-make. Oxidized bronze finish. Takes No. 53 or No. 65 three conductor Plug. Used on trunk circuit No. 120 PBX Switchboards.

Stock No.	Code	Description
201562	(165)	An individual Jack taking No. 53 or No. 65 three conductor Plug. Similar to No. 161, with one make contact.
202488	(166)	An individual jack. Takes No. 55 or No. 63 three conductor plug. Double cut-off type, similar to No. 154. Used in XY Switching Systems.

INDIVIDUAL JACKS (Cont.)

Individual Jacks for Thin Panel Mounting  
No. 147, 151 and 152 Types



Typical Jack—(No. 147)

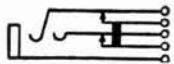

No. 147 Jack  
Spring Combination

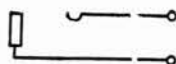

No. 151 Jack  
Spring Combination

These Jacks are all of the same general design, the only difference being in the spring combinations used. They are made to mount on panels varying from 1/8" to 1/4" in thickness by proper adjustment of a nut associated with the Jack frame.

The Jacks are held in place on the front of the panel by this hexagon nut which is nicked to give it an attractive appearance. When this nut is fully drawn down, the frame of the Jack is tightly pressed against the rear of the panel to make a rigid mounting.

Stock No.	Code	Plug Used
801183	(147)	No. 59 (3 Cond.) Nos. 60, 61 (2 Cond.)
801185	(151)	No. 59 (3 Cond.) Nos. 60, 61 (2 Cond.)
801186	(152)	No. 59 (3 Cond.) Nos. 60, 61 (2 Cond.)

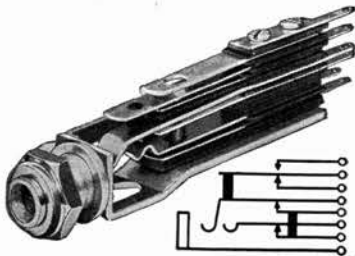

Spring Combination No. 152 Jack

Cord Test Jack

Stock No.	Code	Description
801176	(139)	Used as a cord test jack on multiple switchboard positions. Plug required—No. 53 and No. 65 three conductor, or No. 56 two conductor plugs.



No. 139 Jack Assembly

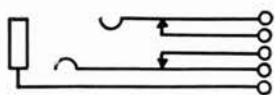

No. 139 Jack  
Spring Combination

Individual Test Jacks  
No. 156 and 157 Types

These Jacks are also furnished with an associated finishing nut similar to the one used with the No. 147, 151 and 152 types. They are used as test jacks in multiple switchboards and, except for taking different plugs, the No. 156 and No. 157 are the same.

Stock No.	Code	Plug Used
800072	(156)	No. 65 (3 Conductor)
802597	(157)	No. 54 (3 Conductor)

Toll Test Jacks

Toll Test Jacks are used primarily for terminating toll lines. They are mounted in pairs or singly in accordance with the circuits. When mounted in pairs a twin type plug is used for test purposes. When mounted singly two or three conductor plugs are used.



No. 144 Jack Assembly

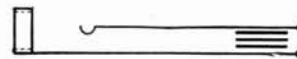

No. 144 Spring Combination

Stock No.	Code	Description
801179	(144)	Individual jack. Mounts on panel 9/16" thick, requires 15/32" drill hole. Used with No. 60 two-conductor plug.
202815	(144-A)	Same, except adjusted for No. 61 two-conductor plug.
801180	(144-A on 87 mtg.)	Same as No. 144-A but on No. 87 two-jack mounting instead of individual

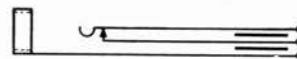

No. 145 Spring Combination

Stock No.	Code	Description
801181	(145)	Same type as No. 144 except spring combination. Adjusted for No. 59 three-conductor plug.
801182	(145-A)	Same as No. 145, adjusted for No. 61 two-conductor plug.

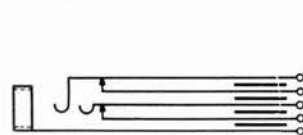

No. 154 Spring Combination



No. 155 Spring Combination

Stock No.	Code	Description
801188	(154)	Same type as No. 144, except spring combination. Takes No. 59 three conductor plug.
801189	(154-A)	Same as No. 154, adjusted for No. 61 two-conductor and No. 62 twin plugs.
801190	(155)	Same type as No. 144, except spring combination. Takes No. 59 three-conductor plug.
800069	(155-A)	Same as No. 155, adjusted for No. 61 two-conductor and No. 62 twin plugs.

## INDIVIDUAL JACKS (Cont.)

### Toll Test Jack Mountings

These mountings are used for placing Nos. 144, 145, 154 and \*155 Jacks on panels in groups of 24 and 48. The material is black hard rubber, each strip being equipped with one designation strip. Two No. 22 Jack Fasteners are used for mounting. No. 93 Mounting is drilled for 4 No. 19 Number Plates, and No. 94 is drilled for 2 Number Plates.

Stock No.	Code	No. of Jacks	Description
200966	(93)	Mounting 48	For Toll Test Panels
200967	(94)	Mounting 24	For Toll Test Panels
	(93)	Mounting—Less designation strip	
	(94)	Mounting—Less designation strip	

When jacks are mounted at the factory an additional charge is made. Number plates and plug hole blanks for unequipped jack spaces are extra and are not furnished unless specified.

\*No. 155 Jacks require vacant spaces between jacks on account of the size of their spring pile-ups. Other jacks mount in adjacent mounting holes of the No. 93 or No. 94 Jack Mounting.

### Wall Outlet Type

Conveniently mounted in walls for extension telephone service. Uses standard single gang outlet box and plastic wall plate equipped with two conductor jack; escutcheon marked "Telephone." Used to advantage with No. 1243 Handset Telephone on metallic (two wire) circuits.

Stock No.	Code	Description
801501	(60)	Two Conductor Plug
25856		Telephone Plug-in Jack Assembly, includes outlet plate with jack assembly, outlet box—2" x 2" x 3" and Plate—2¾" x 4½"
25960		Plug-in Jack Assembly, less outlet box

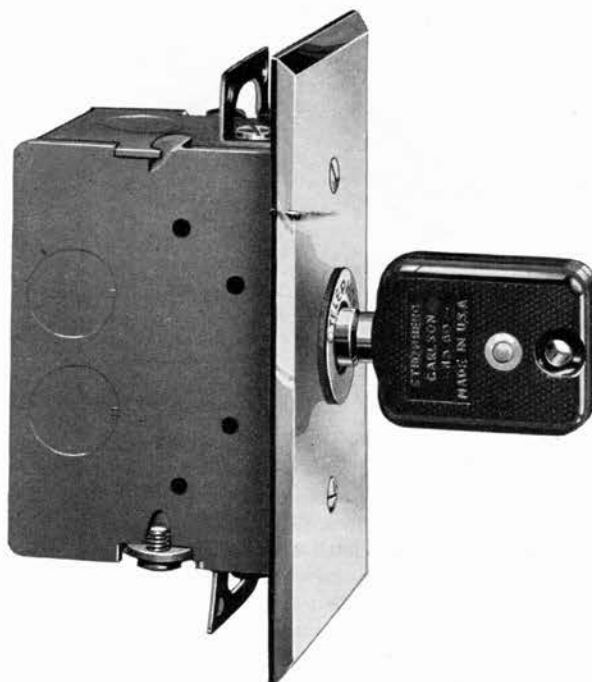

No. 25856 Telephone Plug-in Jack Assembly

## JACKS MOUNTED IN STRIPS

### No. 109 Type

Used as multiple jacks for additions to former standard Stromberg-Carlson Switchboards. Face length—10 15/32", Width—½", Mounting Centers—10 15/16". Uses No. 15 Jack Fasteners and No. 6 Jack Blank. Takes No. 42 or No. 57 two conductor plugs or No. 55 three conductor plug. Replaced by No. 130 Type Jack on all new work.



End View No. 109 Jack

Stock No.	Code	Mounting	No. of Jacks	Group Marking
801088	(109)	59	5	Plain Face
801089	(109)	60	10	Plain Face
801090	(109)	61	20	Plain Face
801091	(109)	62	20	White Line
801092	(109)	63	20	White Line and Party Line indicators
801093	(109)	78	10	Drilled for No. 16 Number Plates

When numbering of jack strips is desired an extra charge is made.

### No. 113 Jack (No. 109 Type)

Used for trunk service on multiple switchboards. Similar to No. 109 Jack, but with spring combination as shown. Takes same plugs, jack fasteners and jack blanks as No. 109 Type.

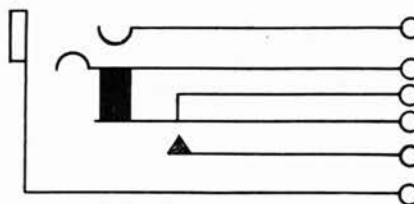

No. 113 Jack  
Spring Combination

Stock No.	Code	Mounting	No. of Jacks	Group Marking
801096	(113)	59	5	Plain Face
801097	(113)	60	10	Plain Face

### Ordering Note

In ordering jacks mounted in strips be sure to specify number of jacks wanted and the mounting desired. For example: order 5 No. 109 Jacks on No. 59 Mounting.

JACKS MOUNTED IN STRIPS (Cont.)

**No. 114 Jack**  
(109 Type)

Formerly used with PBX and Magneto Switchboards. Similar to the No. 109 Jack, but with spring combination as shown. Uses No. 15 Jack Fasteners and No. 6 Jack Blank. Takes No. 42 or No. 57 Two Conductor Plug or No. 55 Three Conductor Plug.

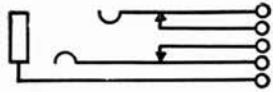

No. 114 Jack Spring Combination

Stock No.	Code	Mounting	No. of Jacks	Group Marking
44491	(114)	59	5	Plain Face
44464	(114)	60	10	Plain Face
801100	(114)	61	20	Plain Face
801101	(114)	62	20	White Line Divisions
801102	(114)	63	20	White Line Divisions— Drilled for party line indication.

**No. 121 Jack**  
(109 Type)

Used with generator call, visual signal multiple switchboards. Similar to No. 109 Jack, but with spring combination as shown. Uses No. 15 Jack Fasteners and No. 6 Jack Blank. Takes No. 42 or No. 57 Two conductor Plug or No. 55 Three Conductor Plug.

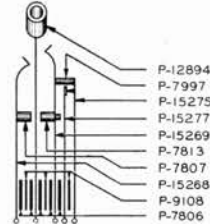

No. 121 Jack Spring Combination

Stock No.	Code	Mounting	No. of Jacks	Group Marking
801113	(121)	60	10	Plain Face
801114	(121)	61	20	Plain Face
801115	(121)	62	20	White Line Divisions
801116	(121)	63	20	White Line Divisions— Drilled for party line indication.

**No. 127 Type**



End View  
No. 127 Jack

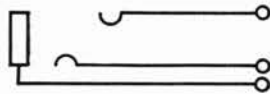

No. 127 Jack Spring Combination

Standard for eight panel multiple switchboards. Mounts—10 or 20 per strip. Length of face— $7 \frac{19}{32}$ ". Width— $\frac{3}{8}$ ". Depth of Jack from face to tip of springs— $2 \frac{29}{32}$ ". Mounting centers— $8 \frac{3}{8}$ ". Takes No. 54 or 54-D three conductor plug. Uses Jack fastener No. 17 and Jack blank No. 45.



No. 127 Jack on 90 Mounting

Stock No.	Code	Mounting	No. of Jacks	Group Marking
801137	(127)	89	10	Plain Face
801138	(127)	91	10	Drilled for No. 60-D Number Plate
42996	(127)	90	20	Plain Face
801139	(127)	90-A	20	White Line Divisions
801140	(127)	90-B	20	White Line Divisions Party Line Indication
801141	(127)	90-C	20	White Line Divisions can be lined on beveled edge to show a group of jacks.

No. 89 Mounting supersedes No. 82 Mounting.  
No. 91 Mounting supersedes No. 88 Mounting.  
No. 90 Mounting supersedes No. 83 Mounting.  
No. 90-A Mounting supersedes No. 83-A Mounting.  
No. 90-B Mounting supersedes No. 83-B Mounting.  
No. 90-C Mounting supersedes No. 83-C Mounting.  
NOTE: No. 127 Jack replaces No. 122 on new work as standard 8 panel Jack.

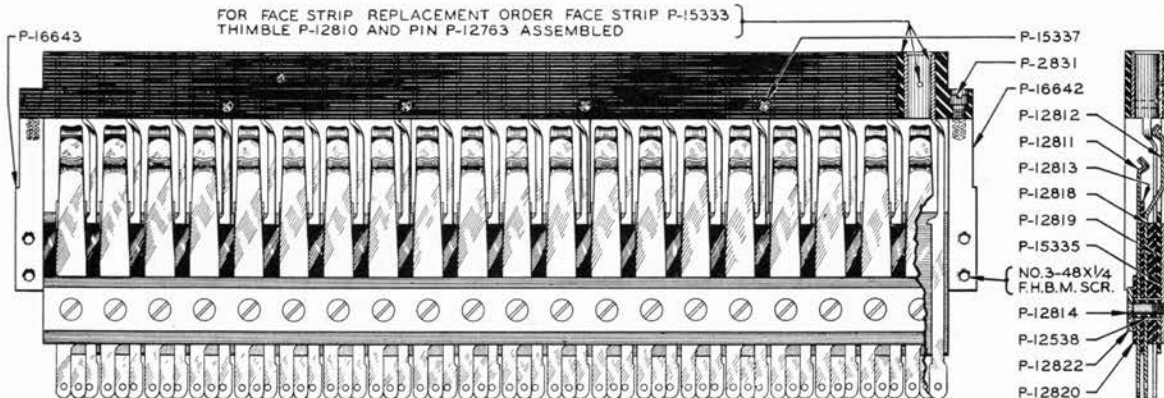

Line Drawing to show parts of No. 90 Mountings for 127 Jack, with their Stock Numbers

## JACKS MOUNTED IN STRIPS (Cont.)

### 130 TYPE

#### No. 130 Jack

For the No. 130 Type Jack two styles of mountings are available—No. 81 (including Nos. 79 and 80) and No. 100 which includes the No. 99 Type.

In the No. 81 type mounting the sleeve spring of each Jack is one continuous piece from the face opening to the wire terminal end.

In the No. 100 type Mounting the sleeve conductor is made in two parts—the ferrule or sleeve which extends through the face strip of the Jack and the terminating conductor to which the ferrule is joined by a threaded screw connection.

This design makes it possible to easily remove a single sleeve for replacement without disturbing the remaining Jacks or the wiring of the strip.

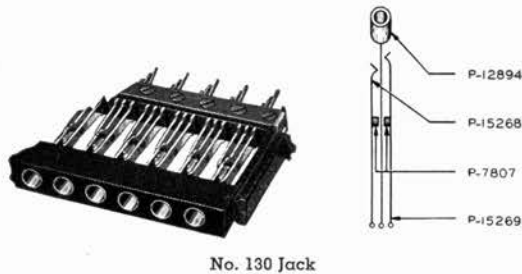

No. 130 Jack

The No. 130 Jack is used in two and six panel multiple switchboards.

Stock No.	Code	Mounting	No. of Jacks
801145	(130)	79	5
801146	(130)	80	10
801147	(130)	81	20
801148	(130)	81-A	20
801149	(130)	81-B	20
48368	(130)	99	10
48371	(130)	100	20
200721	(130)	100-A	20
200730	(130)	100-B	20

Plugs used—No. 56 Type, two conductor and either No. 53 or 65 Type, three conductor.

#### Standard Mountings for No. 130 Type Jack

Selections to meet requirements should be made from the following standard mountings for the No. 130 Type Jack which includes Nos. 130 to 138 inclusive and Nos. 162, 163 and 164.

Mounting Codes	No. of Jacks per Strip	Group Markings
No. 79	5	Plain Face
Nos. 80 or 99	10	Plain Face
Nos. 81 or 100	20	Plain Face
Nos. 81-A or 100-A	20	White line divisions (groups of 5)
Nos. 81-B or 100-B	20	White line divisions and drilled for party line indicators

#### No. 132 and No. 133 Jacks (130 Type)

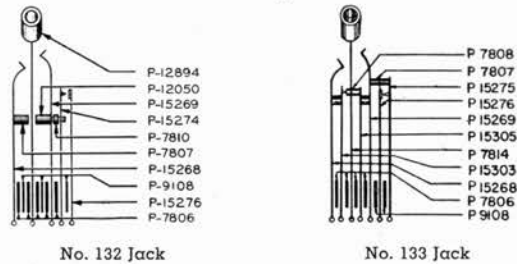

No. 132 Jack

No. 133 Jack

Same as No. 130 except spring combination. Used in trunk circuits. Nos. 132 and 133 Jacks on 79 and 80 mountings only (5 and 10 per strip) have been replaced by corresponding No. 134 type Jacks.

#### No. 132 Jack

Stock No.	Code	Mounting	No. of Jacks
801152	(132)	81	20
801153	(132)	81-A	20
801154	(132)	81-B	20
48372	(132)	100	20
200722	(132)	100-A	20
200731	(132)	100-B	20

#### No. 133 Jack

Stock No.	Code	Mounting	No. of Jacks
801155	(133)	81	20
801156	(133)	81-A	20
801157	(133)	81-B	20
48373	(133)	100	20
200723	(133)	100-A	20
200732	(133)	100-B	20

Plugs used—No. 56 Type, two conductor and either 53 or 65 type, three conductors.

#### No. 130 Type Jack Data

Used for two and six panel multiple switchboards. This type includes the following jacks:

Nos. 130 to 138 and Nos. 162, 163 and 164

Length of face—10 $\frac{3}{8}$ "

Width of face—31 $\frac{1}{64}$ "

Mounting Strip Centers—11 1/16"

Depth, face to spring tips—3"

Plug used—No. 56 Type (two conductor)

No. 53 or 65 Type (three conductor)

Jack Fastener—No. 17 (2); Jack Blank—No. 52

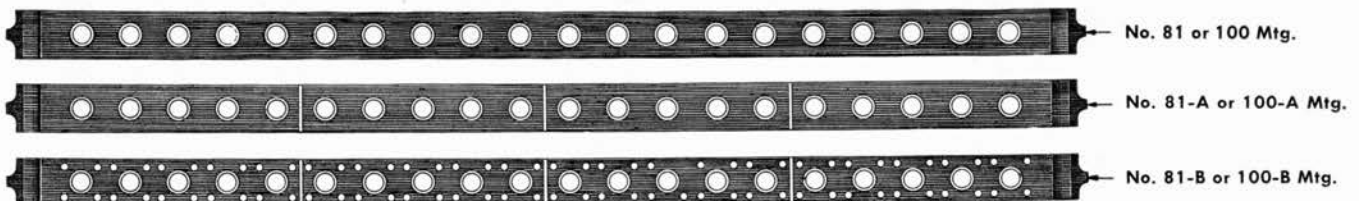

Jack Mountings Used with No. 130 Type Jacks

JACKS MOUNTED IN STRIPS (Cont.)

130 TYPE

**No. 134 Jack**  
(130 Type)

No. 134 same as No. 130 except for spring combinations. Used in trunks and transfer circuits.

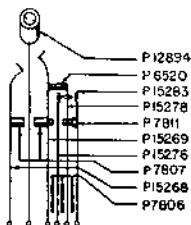

No. 134 Jack

Stock No.	Code	Mounting	No. of Jacks
801158	(134)	79	5
801159	(134)	80	10
48367	(134)	99	10

**No. 135 Jack**  
(130 Type)

No. 135 same as No. 130 except for spring combinations. Used in Nos. 101, 102 and 106 PBX Switchboards.

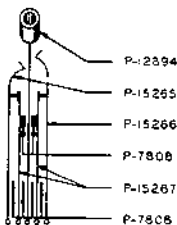

No. 135 Jack

Stock No.	Code	Mounting	No. of Jacks
801160	(135)	79	5
801161	(135)	80	10
801162	(135)	81	20
801163	(135)	81-A	20
801164	(135)	81-B	20
48366	(135)	99	10
48374	(135)	100	20
200724	(135)	100-A	20
200733	(135)	100-B	20

Plugs used—No. 56 Type, two conductor and either No. 53 or 65 Type, three conductor.

**No. 137 Jack**  
(130 Type)

Same as No. 130 except for spring combinations. Used in trunk circuits.

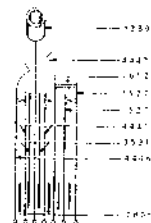

No. 137 Jack

Stock No.	Code	Mounting	No. of Jacks
801170	(137)	79	5
801171	(137)	80	10
44239	(137)	81	20
48364	(137)	99	10
48376	(137)	100	20
200726	(137)	100-A	20
200735	(137)	100-B	20

**No. 138 Jack**  
(130 Type)



No. 138 Jack

Stock No.	Code	Mounting	No. of Jacks
801172	(138)	80	10
801173	(138)	81	20
801174	(138)	81-A	20
801175	(138)	81-B	20
48363	(138)	99	10
48377	(138)	100	20
200727	(138)	100-A	20
200736	(138)	100-B	20

Plugs used—No. 56 Type, two conductor and either No. 53 or 65 Type, three conductor.

Jack strips are furnished without numbers unless otherwise specified.

## JACKS MOUNTED IN STRIPS (Cont.)

### 130 TYPE (Cont.)

#### No. 162 Jack (130 Type)

Same as No. 130 except for spring combinations. Used in trunk circuits.

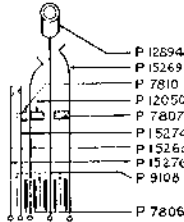

No. 162 Jack

Stock No.	Code	Mounting	No. of Jacks
802602	(162)	80	10
802603	(162)	81	20
802604	(162)	81-A	20
802605	(162)	81-B	20
48360	(162)	99	10
48378	(162)	100	20
200728	(162)	100-A	20
802737	(162)	100-B	20

#### No. 164 Jack (130 Type)

Same as No. 130 except for spring combinations. Used in trunk circuits.



No. 164 Jack

Stock No.	Code	Mounting	No. of Jacks
800092	(164)	80	10
48362	(164)	99	10

Plug used—No. 56 Type, two conductor and either No. 53 or 65 Type, three conductor.

NOTE—Mountings shown are the only ones available for the No. 164 Type Jack.

#### No. 163 Jack (130 Type)



No. 163 Jack

Stock No.	Code	Mounting	No. of Jacks
802606	(163)	80	10
802607	(163)	81	20
802608	(163)	81-A	20
802609	(163)	81-B	20
48361	(163)	99	10
48379	(163)	100	20
200729	(163)	100-A	20
200738	(163)	100-B	20

Plug used—No. 56 Type, two conductor and either No. 53 or 65 Type, three conductor.

#### Jack Fasteners

Jack fasteners are used for mounting jack and lamp socket strips and jack blanks on switchboard stiles. For the proper type to use refer to separate descriptions of standard jacks and lamp sockets which will be found in this section.

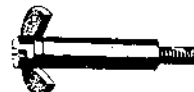

No. 17 Jack Fasteners



No. 18 Jack Fasteners

Stock No.	Code	Jack Used	Jack Mounting	Lamp S'ckt Used	Lamp S'ckt Mounting
8867	(15)	109	59, 60, 61, 62, 63, 78	121	59, 60, 61
801197	(17)	127	82, 83, 88	121	82, 83, 88
801197	(17)	130	79, 80, 81, 99, 100	121	79, 80, 81
801198	(18)	*	-----	---	-----
801199	(19)	*	-----	---	-----
†801200	(20)	109	-----	121	-----
801201	(21)	127	89, 90, 91	121	89, 91, 92
801202	(22)	144	86, 87, 93, 94	121	-----

\*Nos. 18 and 19 used with Jack blanks in unfilled spaces, above multiple, of Nos. 127 and 130 Jacks.

†No. 20 used when stile strips in switchboards are drilled on 1" centers.

#### Jack Blanks

Jack blanks are available for filling unoccupied spaces of standard jacks, or lamps combined with jacks, in single strips or groups.

These blanks may be black formica with satin finish or various woods with and without holly strip edges, depending upon requirements to be met.

In ordering jack blanks the type of jack or lamp socket strip should be specified by its proper code number.

## KEYS

Stromberg-Carlson Keys are furnished in many designs to meet the specific requirements of the circuits in which they are used. Types available include cam lever keys with surface or flush mountings, key units on mountings with ring-off drops and party line indicating keys as well as plunger, twist type and push buttons keys on individual mountings or in strips of standard size. All springs are high grade nickel silver, long and flexible, with contacts of precious metal which effectively prevents corrosion. The assemblies are rigidly mounted and this, together with the use of phenolfibre insulations of the best quality, assures uniformly good performance under all operating conditions.

### CAM KEYS

Cam keys are designed principally for use in circuits in which switching, ringing or listening service is required.

These Keys are equipped with free action roller type cams and can be arranged for either one-way or two-way operation in both locking and non-locking types.

Standard spring combinations will meet the requirements of most circuits in which cam type keys are essential but, keys with other combinations can be furnished if ordered in substantial quantities. To avoid specifying special keys it is sometimes possible to use a larger standard key having spring com-

binations that are not needed, provided of course, that the remaining combinations will fulfill the requirements to be met.

Both the cam and spring combinations are attached to a cadmium-plated frame of pressed steel which forms a rigid mounting that keeps the assembly in proper alignment.

Each spring combination is built up separately and mounted on either side of the frame with a heavy (6-32) machine screw.

This arrangement makes it an easy matter to change or replace spring combinations without dismantling the key.

### NO. 340 TYPE CAM KEYS

The No. 340 Type Key, while retaining the advantages of earlier cam keys, has been built with new refinements which assure greater dependability and better operation than ever before.

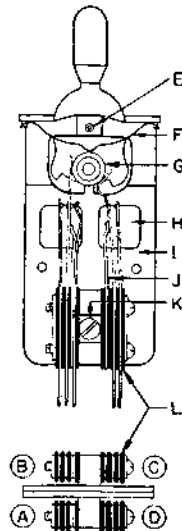

Line Drawing of Typical No. 342 Key.

#### Key Mountings

Key mounting is required for all cam type keys and this should be ordered as a separate item.

Mountings are available for flush or surface type keyboards and also for use when the keys are mounted in the switchboard face.

For more detailed information see "Key Mountings".

#### Features

- E. Securely staked pin—prevents cam from loosening.
- F. Non-click Buffer Spring—prevents back-lash. This is an optional feature, signified by "X" added to code number.
- G. Rotating Roller—equalizes wear, eliminates flats.
- H. Frame Openings—expose spring action on both sides of frame.
- I. Generous Sheet Metal Frame—provides space for large number of springs.
- J. Spring Stops—permit accurate adjustments.
- K. Heavy Retaining Screw—anchors spring assemblies securely and allows spring combinations to be easily replaced or changed.
- L. Heat Treated Phenolic Insulations, extending beyond springs—retain thickness dimensions and prevent loosening of spring stacks.

#### Method of Ordering Key Mountings

In ordering complete cam type keys the number of the desired mounting should be shown in addition to the number of No. 340 Type Key that has been selected. Examples:

##### Two Keys on Flush Mounting

1 — 802683	(340-A)	Key	mounted on
1 — 802684	(340-B)	Key	mounted on
1 — _____	(93)	Key	Mounting

##### One Key on Surface Mounting

1 — 802683	(340-A)	Key on
1 — _____	(66)	Key Mounting

For these and other standard Key Mountings see "Key Mountings" further along in this section.

**NO. 340 TYPE KEYS (Cont.)**

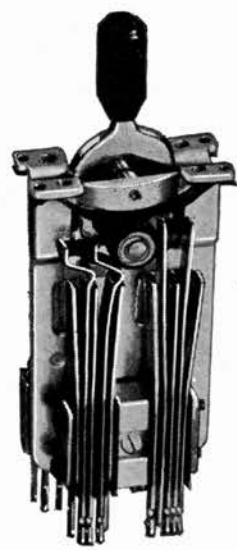

No. 342 Type Key without Key Mounting

The following ordering information for No. 340 Type Keys shows type of contact (Figs. 1 to 6) and positions (A, B, C, D) of springs. (See Line drawings). The numerals in parentheses represent the number of combinations of the type designated at the head of each column, as A(1), B(2), D(3). For example, No. 342-N Key or No. 342-NX with non-click springs has the following contact springs:

- "A" Position One break-make
- "B" Position One break-make, one make
- "C" Position One break-make, four makes
- "D" Position One break-make, four makes

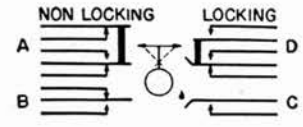

"X" added to code number indicates the same spring combinations with non-click buffer springs, as No. 342-AX.

"Z" added to code number indicates brass finished cam for those keys used on No. 120,121 Switchboards. See PBX Boards.

Contact Springs are shown in the non-operated (normal) position.

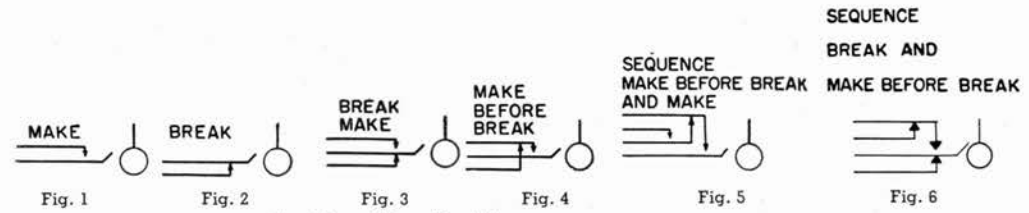

Stock No. Code

- 802683 (340-A)
- 802684 (340-B) C(1), D(1)
- 802685 (340-C)
- 802686 (340-D)
- 802687 (340-E) C(1), D(1)
- 802688 (340-F)
- 802689 (340-G) C(3), D(3)
- 201852 (340-H) A(2), B(1)

**I—One-Way Locking**

- C(1), D(1)
- C(2), D(2)
- C(2), D(2)
- A(1), B(1)
- C(1), D(1)
- C(2), D(2)
- A(1), B(1)

**II—One-Way, Non-Locking**

- 802692 (341-A)
- 802693 (341-B) A(1)
- 802694 (341-C)

- A(1), B(1)
- A(1), B(1)
- A(2), B(2)

**III—Two-Way Locking, Non-Locking**

- 802696 (342-A)
- 802704 (342-AX)
- (342-B) C(1), D(1)
- 802705 (342-BX)
- 42840 (342-C) C(1), D(1) C(1)
- 802707 (342-CX)
- 42889 (342-D) C(1), D(1) A(1)
- 802709 (342-DX)
- (342-E) C(2), D(2) A(1)
- 802711 (342-EX)
- 200858 (342-F) A(1)
- 801712 (342-FX)

- A(1), B(1), C(1), D(1)
- A(1), B(1)
- A(1), B(1)
- A(1), B(1), D(1)
- A(1), B(1)
- A(1), B(1), C(1), D(1)

NO. 340 TYPE KEYS (Cont.)

Contact Springs are shown in the non-operated (normal) position.

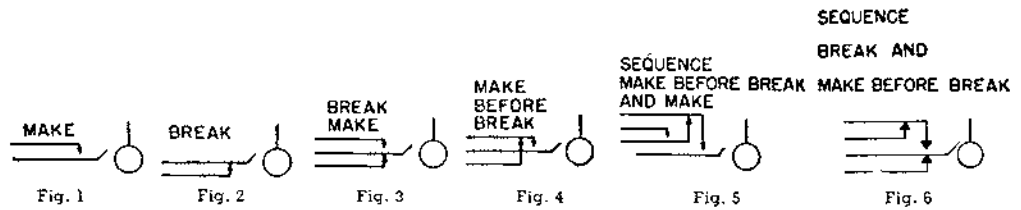

III—Two-Way Locking, Non-Locking (Cont.)

Stock No.	Code	Fig. 1	Fig. 2	Fig. 3	Fig. 4	Fig. 5	Fig. 6
802697	{342-G}	B(1), C(1)		A(1), B(1), C(1), D(1)			
200863	{342-GX}						
802698	{342-HI}			B(1), C(2), D(2)	A(1)		
802714	{342-HX}						
_____	{342-JI}	A(1)	C(1), D(1)	A(1), B(1), C(1), D(1)			
802716	{342-JX}						
_____	{342-KI}	C(1), D(1)		A(1), B(1)	C(1), D(1)		
802717	{342-KX}						
802699	{342-LI}	C(2), D(1)		A(1), B(1), D(1)			
802719	{342-LX}						
_____	{342-MI}	B(1), C(1), D(1)		A(1), B(1)	C(1), D(1)		
802720	{342-MX}						
802700	{324-NI}	B(1), C(4), D(4)		A(1), B(1), C(1), D(1)			
41867	{342-NXI}						
_____	{342-PI}	A(1), C(2), D(1)	D(1)	A(1), B(1)			
802721	{342-PX}						
802701	{342-QI}	C(4), D(4)	C(2), D(2)	A(1), B(1)			
42895	{342-QXI}						
201231	{342-RI}	A(1), B(1), C(1), D(1)		A(1), B(1)	C(1), D(1)		
802722	{342-RXI}						
802702	{342-SI}			A(1), B(1), C(2), D(2)			
802703	{342-SXI}						
49990	{342-TI}	A(1)		A(1), B(1), C(2), D(2)			
802724	{342-TXI}						
_____	{342-UI}	A(1), B(1)		A(1), B(1), D(1)		C(1)	
802725	{342-UXI}						
_____	{342-VI}	D(1)		A(1), B(1)			C(1), D(1)
802726	{342-VXI}						
_____	{342-WI}			A(1), B(1)		C(1)	D(1)
802727	{342-WXI}						
_____	{342-YI}			A(1), B(1), C(1), D(1)		D(1)	
802728	{342-YXI}						
_____	{342-AAI}			A(1), B(1), C(1), D(1)		C(1), D(1)	
42603	{342-AAXI}						
_____	{342-BBI}	C(2), D(2)	C(1), D(1)	A(1), B(1)			
_____	{342-BBXI}						
_____	{342-CCI}	C(2), D(2)		A(1), B(1)	C(1), D(1)		
802732	{342-CCXI}						
40729	{342-DDI}		C(1), D(1)	A(1), B(1)			C(1), D(1)
_____	{342-DDXI}						

## NO. 340 TYPE KEYS (Cont.)

Contact Springs are shown in the non-operated (normal) position.

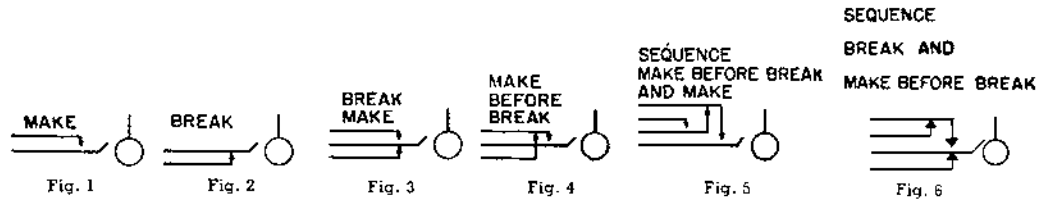

### IV—Two-Way Locking and Locking

Stock No.	Code	Fig. 1	Fig. 2	Fig. 3	Fig. 4	Fig. 5	Fig. 6
802739	{343-A}			A(1), B(1), C(1), D(1)			
802740	{343-B}	A(1), B(1), C(1), D(1)					
802741	{343-C}			A(2), B(2), C(2), D(2)			
802742	{343-D}	A(1)		C(2), D(2)	A(1), B(1)		
802743	{343-E}	B(1), C(1)		A(1), B(1), C(1), D(1)			
-----	{343-F}			A(1), B(1), C(1), D(1)		A(1), D(1)	
802744	{343-G}		C(1), D(1)		A(1), B(1)		C(1), D(1)
-----	{343-H}		A(1), B(1), D(1)			A(1), B(1), C(1), D(1)	
802745	{343-J}	B(1), C(1)		A(1), B(1), C(1), D(1)	A(1), D(1)		
802746	{343-K}			A(1), B(1), C(1), D(1)		D(1)	
800699	{343-L}	A(1), B(1), C(1), D(1)	A(1), B(1) C(1), D(1)		A(1), B(1), C(1), D(1)		
42841	{343-M}	A(3), B(3), C(3), D(3)					
-----	{343-N}	A(2), B(2), C(1), D(1)		C(1), D(1)		C(1), D(1)	
800095	{343-P}	A(1)	C(2), D(1)	C(1), D(1)	A(1), B(1)		
800073	{343-Q}	C(1), D(1)		A(1), B(1)	C(1), D(1)		
45493	{343-R}	A(1), B(1), C(1), D(1)	A(1), C(1)	A(1), B(1), C(1), D(1)			
200459	{343-S}	A(2), B(1), C(1), D(1)					
200979	{343-T}	D(1)	A(1)	A(2), B(2)	C(1), D(2)		
201782	{343-U}	A(2), B(1), C(1)	C(1), D(3)		A(1), B(1),		

### V—Two-Way Non-Locking and Non-Locking

802757	{344-A}			A(1), B(1), C(1), D(1)			
-----	{344-B}	A(1), B(1), C(1), D(1)		A(1), B(1), C(1), D(1)			

### VI—One-Way Locking; Three Position (Tilted Handles)

802760	{345-A}	C(1)			A(1), B(1), C(1), D(1)		
802761	{345-B}	C(1)	A(1), B(1) D(1)		C(1), D(1)		
-----	{345-C}	C(2), D(2)	A(1), B(1)		C(1), D(1)		
49016	{345-D}		A(1), B(1), C(1), D(1)		C(1), D(1)		
42352	{345-E}			A(1), B(1), C(1), D(1)			

### Key Blanks

Used for filling the space of key mountings. Both surface and flush mounting types can be furnished for Nos. 340 and 170 Type Cam Keys.

**NO. 170 TYPE CAM KEYS**

This key is designed for use in circuits where dependable switching, ringing or listening service is required without the use of "non-click" springs which are optional in the No. 340 Cam Lever type.

Both the cam and the springs of the No. 170 Type Key are built on a rigid frame of punched steel with rust-proofed finish. Provision is made for either one-way or two-way cam levers and either locking or non-locking combinations. The No. 170 Type Key has a frame with steel top but does not include a key mounting which may be selected from types shown immediately after the Key section under "Key Mountings".

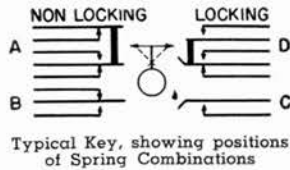

No. 170-A Type Key without Key Mounting

**One Way, Locking**

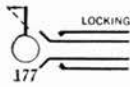

Stock No.	Code	Position	Contact Description
802626	(177-A)	C	One make
		D	One make
802628	(179-A)	C	One break-make
		D	One break-make

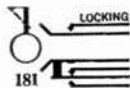
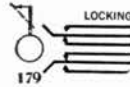

Stock No.	Code	Position	Contact Description
49759	(181-A)	C	One make
		D	One sequence make, break-make
802632	(188-A)	C	Two break-makes
		D	Two break-makes

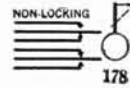
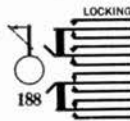

**One Way, Non-Locking**



Stock No.	Code	Position	Contact Description
802627	(178-A)	A	One break-make
		B	One break-make
802640	(195-A)	A	One make-before-break

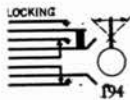

Stock No.	Code	Position	Contact Description
802638	(194-A)	A	One make-before-break
			One make
		B	One make-before-break
		C	One make-before-break, one break
		D	One make-before-break, two breaks

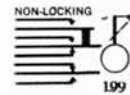
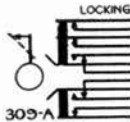

Stock No.	Code	Position	Contact Description
802645	(199-A)	A	One break-make, one make
		B	One break-make
802681	(330-A)	A	One break-make
		B	One break-make

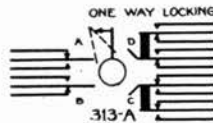
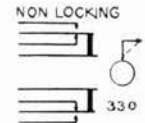

Stock No.	Code	Position	Contact Description
802664	(313-A)	A	One break-make
		B	One break-make
		C	Two break-makes
		D	Two break-makes
802675	(323-A)	C	One break, one make
		D	One make

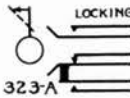

**Two Way, Locking and Non-Locking**



Stock No.	Code	Position	Contact Description
802619	(170-A)	A	One break-make
		B	One break-make
		C	One break-make
		D	One break-make
802622	(173-A)	A	One break-make
		B	One break-make
		C	One make
		D	One make

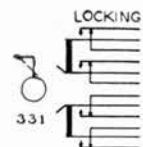

Stock No.	Code	Position	Contact Description
802682	(331-A)	C	Two make-before-breaks
		D	Two make-before-breaks

## NO. 170-A TYPE CAM KEYS

### Two Way, Locking and Non-Locking (Cont.)



Stock No.	Code	Position	Contact	Description
802623	(174-A)	A	A	One break-make
			B	One break-make
			C	One make sequence with one break-make
			D	One make
802625	(176-A)	A	A	One break-make
			B	One break-make
			C	One break-make
			D	One break-make, one break

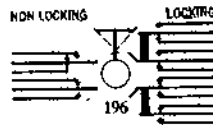

Stock No.	Code	Position	Contact	Description
802643	(197-A)	A	A	One break-make, one make
			B	One break-make
			C	One break-make, one break
			D	One break-make, one break

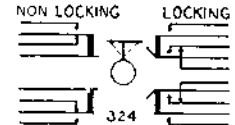

Code	Position	Contact	Description
(308-A)	A	A	One break-make, one break
		B	One break-make
		C	Two makes
		D	One break-make, two makes



Stock No.	Code	Position	Contact	Description
802629	(182-A)	A	A	One break-make
			B	One break-make
			C	One break, one make
			D	One make

Stock No.	Code	Position	Contact	Description
201055	(183-A)	A	A	One break-make
			B	One break, double make
			C	One break, one make
			D	One double make

Stock No.	Code	Position	Contact	Description
802676	(324-A)	A	A	One break-make
			B	One break-make
			C	One make-before-break, one make
			D	One make-before-break, one make

Stock No.	Code	Position	Contact	Description
802680	(329-A)	A	A	One break-make
			B	One break-make
			C	One break-make
			D	One break-make



Stock No.	Code	Position	Contact	Description
802630	(184-A)	A	A	One break-make, one make
			B	One break-make
			C	One make
			D	One break-make, one make

Stock No.	Code	Position	Contact	Description
42665	(187-A)	A	A	One break-make, one break
			B	One break-make
			C	Two makes
			D	Two makes

### Two Way, Locking and Locking



Stock No.	Code	Position	Contact	Description
802621	(172-A)	A	A	One break-make
			B	One break-make
			C	One break-make
			D	One break-make

Stock No.	Code	Position	Contact	Description
802624	(175-A)	A	A	Two break-makes
			B	Two break-makes
			C	Two break-makes
			D	Two break-makes



Stock No.	Code	Position	Contact	Description
802633	(189-A)	A	A	One break-make, one make
			B	One break-make
			C	One break-make
			D	One break-make

Stock No.	Code	Position	Contact	Description
802637	(193-A)	A	A	One break-make
			B	One break-make, one make
			C	One break-make, one make
			D	One break-make

Stock No.	Code	Position	Contact	Description
802642	(196-A)	A	A	One make-before-break
			B	One break-make
			C	Two break-makes
			D	Two break-makes



Stock No.	Code	Position	Contact	Description
802631	(185-A)	A	A	One make
			B	One make
			C	One make
			D	One make

Code	Position	Contact	Description
(186-A)	A	A	One break, one make
		B	One break
		C	One break-make, one make
		D	One make

**NO. 170-A TYPE CAM KEYS (Cont.)  
Two Way, Locking and Locking (Cont.)**



Stock No.	Code	Position	Contact Description
802644	(198-A)	A	One make-before-break, one make
		B	One make-before-break
		C	Two break-makes
		D	Two break-makes
802665	(314-A)	A	One make-before-break, one break, one make
		B	One make-before-break, two breaks
		C	One make-before-break
		D	One make-before-break



802670	(318-A)	A	One break-make
		B	One break-make, one make
		C	One break-make, one make
		D	One break-make
802674	(321-A)	A	One break-make, one make
		B	Two makes
		C	Two makes
		D	One break, one make

**Two Way, Non-Locking and Non-Locking**

Stock No.	Code	Position	Contact Description
802620	(171-A)	A	One break-make
		B	One break-make
		C	One break-make
		D	One break-make

**Key Mountings**

Keys are furnished without mountings unless otherwise specified. Standard key mountings in flush and surface types will be found under "Key Mountings" which follow the Key section.

**NO. 350 COMBINED KEY AND DROP TYPE**



No. 350 Type Key Assembly

This compact unit consists of a combined ringing and listening key, an individual ring-back key and two ring-off drops with automatically restored shutters—all mounted on a rigid steel plate measuring 7 1/4" x 1 1/8".

The No. 350 Type Key, as a unit replaces and is interchangeable with the No. 169 Type. Both keys were used on the Stromberg-Carlson No. 105 Magneto Switchboard and this, in turn, has been replaced by the new No. 125 Type which is fully described in Section B of this catalogue.

**No. 350 Type Key**

Stock No.	Code	Resistance	Description
802763	(350-A)	500 Ohms	Double ring-off drops
802764	(350-B)	1000 Ohms	Double ring-off drops
200021			No. 350-B Key less (two) Coils

**Cam Key Assembly**

Stock No.	Description
34069	Cam Key only, completely assembled

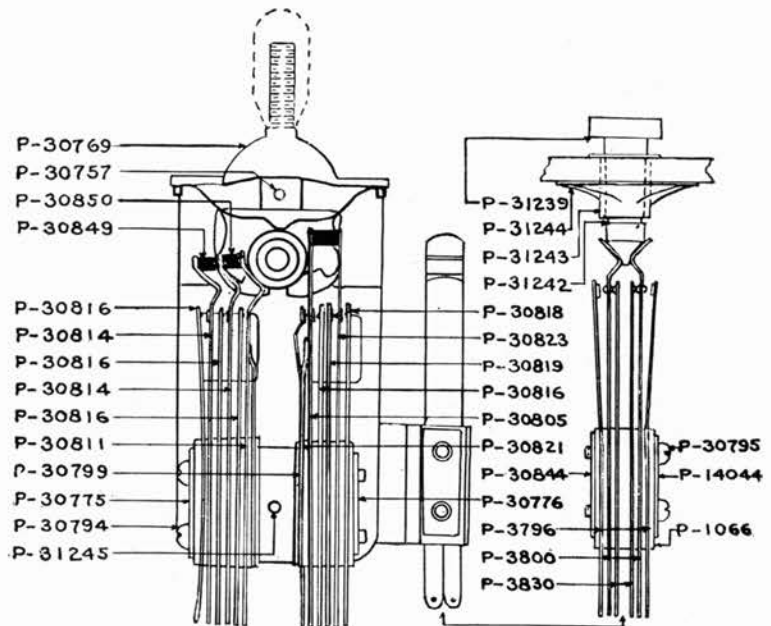
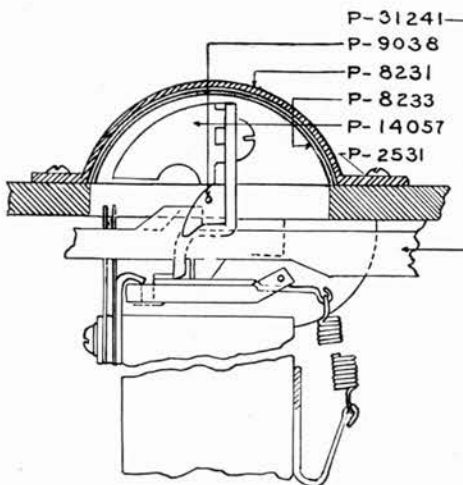

Line Drawing showing parts of the No. 350 Key

## PARTY LINE INDICATING TYPE KEYS

### No. 202 Type Key

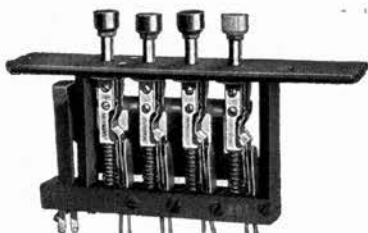

No. 202 Key Assembly



No. 202 Key Spring Combination

A four button, indicating, party line ringing key. Adapted to switchboards that are equipped with either "Manual" or "Machine Ringing" facilities. Each button has three positions—fully depressed, partially released or indicating, and fully released or normal. The spring combinations individual to each button are actuated when any button is in its "indicating position". The spring combination which is operated by the tumbler plate is actuated only when one of the buttons is in its "fully depressed" position. Each button is fully restored automatically when another button is depressed. The buttons are colored blue, red, green and black. Size of key top—5½" x 1".

Depth of key from surface of escutcheon to the tips of springs—2¾". Key top mounts flush with keyboard's surface and is finished in dull black. For keys on other sized mountings see table below.

Stock No.	Code	Description	No. of Cam Keys
802646	(202)	Four Party Indicating Key	None

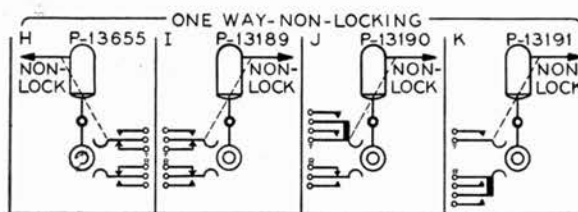
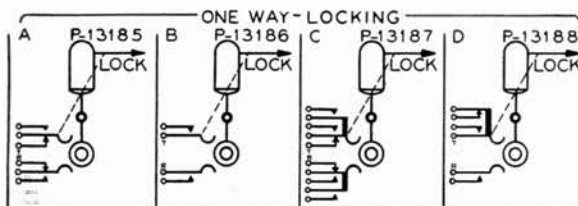

Cam Key Combinations used with Party Line Keys  
Code Nos. 210 to 259

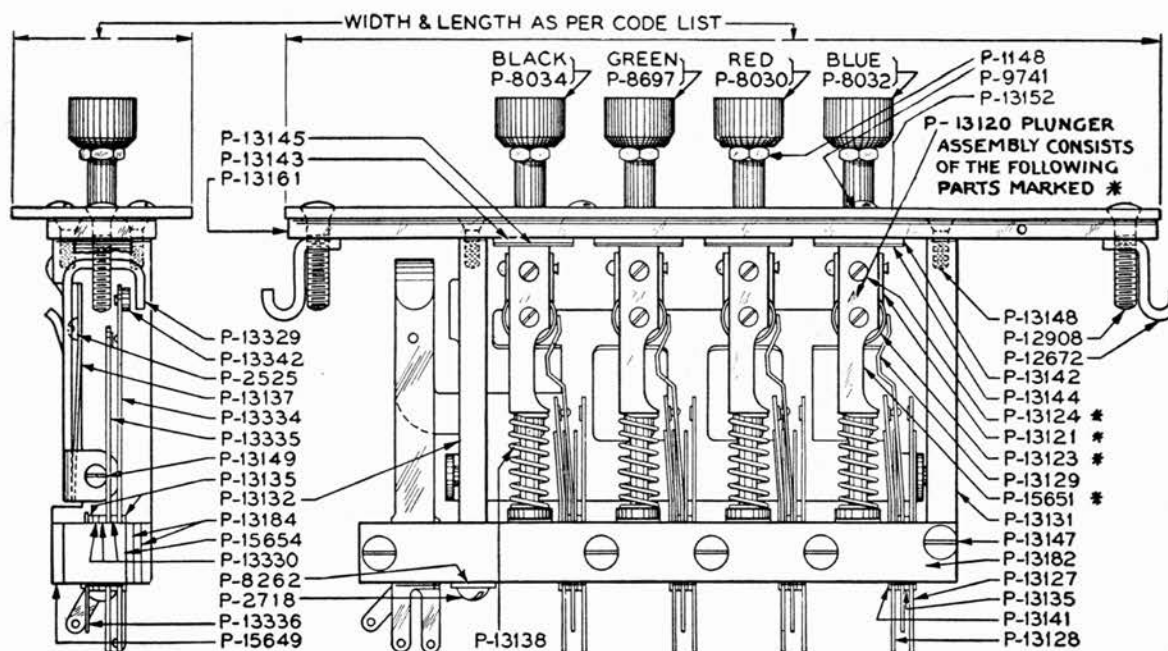

CODE LIST			
CODE NO.	WIDTH	LENGTH	ESC.
200	1¼"	5½"	P-13151
201	1⅝"	5½"	P-13152
202	1"	5½"	P-13153
203	¾"	5½"	P-13154
204	4⅞"	5½"	P-13155
205	1¼"	6½"	P-13156
206	1⅝"	6½"	P-13157
207	1"	6½"	P-13158
208	¾"	6½"	P-13159
209	4⅞"	6½"	P-13160

Line Drawing to Show Piece Parts, with Code Numbers of Nos. 200 through 209 Key Assemblies

**PARTY LINE INDICATING TYPE KEYS (Cont.)**

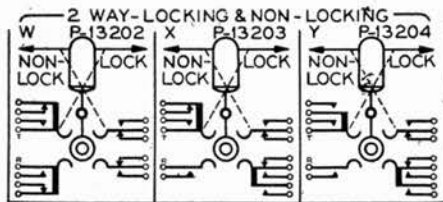
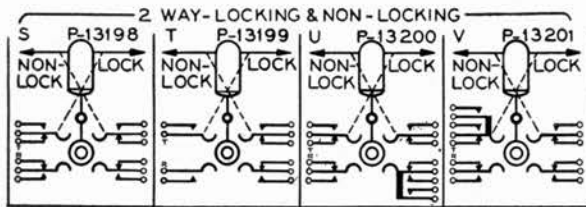
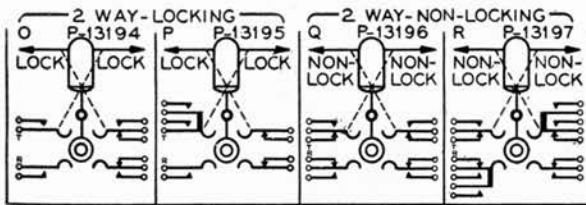

Cam Key Combinations used with Party Line Keys  
Code Nos. 210 to 259

**No. 212 Type Key**

This is a four button, indicating, party line ringing key combined with a cam type listening key. The action of the buttons is the same as that of the No. 202 Key. Used in cord circuits which are designed for "Machine Ringing" and "Manual Listening".

The buttons are colored blue, red, green, and black.  
Size of key top—5½" x 1". Depth of key from the surface of escutcheon to the tips of the springs—2¾".

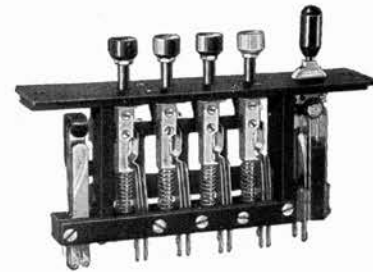

No. 212-B Key Assembly

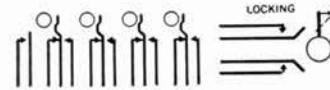

No. 212-B Key Spring Combinations

Stock No.	Code	Description	No. of Cam Keys
—	(212-B)	Four Party, Machine Ringing Key	One

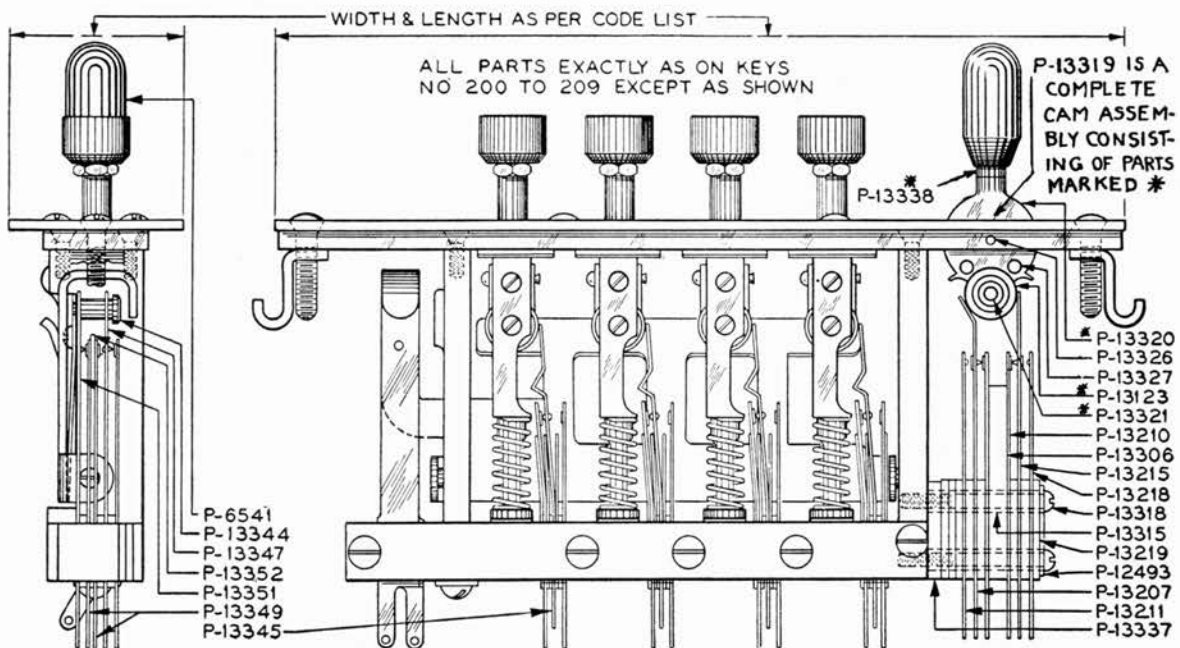

CODE NO.		CODE NO.		WIDTH	LENGTH	ESC	CODE NO.		CODE NO.		WIDTH	LENGTH	ESC
210	220	1¼"	5½"	P-13165	215	225	1¼"	6½"	P-13170				
211	221	1⅝"	5½"	P-13166	216	226	1⅝"	6½"	P-13171				
212	222	1"	5½"	P-13167	217	227	1"	6½"	P-13172				
213	223	¾"	5½"	P-13168	218	228	¾"	6½"	P-13173				
214	224	4/64"	5½"	P-13169	219	229	4/64"	6½"	P-13174				

Line Drawing to show Piece Parts and their Code Numbers of No. 210 through 219 Key Assemblies

## PARTY LINE INDICATING TYPE KEYS (Cont.)

### No. 222 Type Key

A four button, indicating, party line ringing key with a one-way locking cam. Adapted to local common battery cord circuits which are arranged for Manual Four Party Harmonic Ringing and Manual Listening.

The key plungers have three positions—ringing, indicating and normal. The spring combinations individual to each button are actuated in the fully depressed position, but not until after the tumbler plate has actuated the common end springs. Both the end springs and the springs associated with a depressed button return to normal as the button is released to its indicating position. Each button remains in its indicating position until it is fully restored automatically when another button is depressed. The buttons are colored blue, red, green, and black.

Size of keytop— $5\frac{1}{2}$ " x 1". Depth of key from the surface of escutcheon to the tips of the springs— $2\frac{3}{4}$ ".

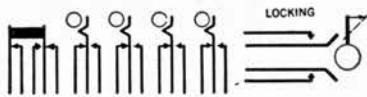

No. 222-B Key Spring Combination

Code No.	Description	No. of Cam Keys
222-B	Four Party, Manual Ringing Key	One

### No. 232-WH Type Key

This key consists of a four button, indicating, party line ringing key mounted with two cam keys. The action of the buttons and the spring combinations controlled by the buttons is identical with that of the No. 202 Key.

Used in universal cord circuits which are designed for the following features—Four Party "Machine Ringing", "Manual Listening", and with provision for manual toll ringing on either cord end.

Size of key top— $6\frac{1}{2}$ " x 1". The buttons are colored blue, red, green and black.

Depth of key from surface of escutcheon to the tips of springs— $2\frac{3}{4}$ ".



232-WH Key Assembly  
No. 232-WH Key Spring Combination

Code No.	Description	No. of Cam Keys
232-WH	Four Party, Machine Ringing Key	Two

### No. 237-WH Type Key

An indicating, four button, party line key mounted with two cams. Used in universal cord circuits that are designed for—"Manual Party Line Ringing" on the calling cord end, "Manual Party Line Ringing" on the answering cord end, "Manual Toll Ringing" on either cord end and "Manual Listening" bridged across the cord circuit.

The operation of the buttons is similar to that described for the No. 222-B Key. The buttons are colored blue, red, green and black.

Size of key top— $6\frac{1}{2}$ " x 1". Depth of key from surface of escutcheon to the tips of springs— $2\frac{3}{4}$ ".

### No. 237—WH Type Key (Cont.)

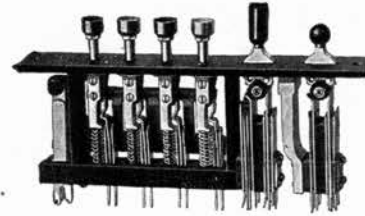

No. 237-WH Key Assembly



No. 237-WH Key Spring Combination

Code No.	Description	No. of Cam Keys
237-WH	Four Party, Manual Ringing Key	Two

### No. 252 Type Key

Similar to No. 212 except that it is equipped with a locking cam key which allows ringing over both sides of lines to ground—8 Party. Position of cam indicates whether "tip" or "ring" side of line is being rung. Size of key top— $7\frac{1}{4}$ " x 1".

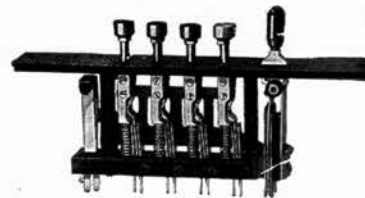

No. 252-A Key Assembly

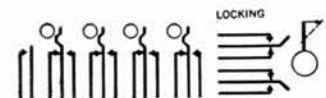

No. 252-A Key Spring Combination

Code No.	Description	No. of Cam Keys
252-A	Eight Party Master Key	One

### No. 262 Type Key

This key is of the four button, indicating, party line type adapted for use as an individual, manual harmonic selective ringing push button key on local to local trunk circuits. The key plungers have three positions; ringing, indicating, and normal. The spring combinations, that are individual to each button, are actuated only in the fully depressed position and not until after the tumbler has actuated the common end springs. Both the end springs and the springs associated with a depressed button return to normal when the button is released to its indicating position. Each button remains in its indicating position until it is fully restored automatically when another button is depressed. Similar to No. 202 but has different end spring combination.

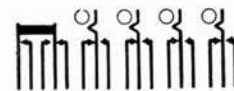

No. 262 Key Spring Combination

Code No.	Description	No. of Cam Keys
262	Four Party, Manual Ringing Key	None

**PARTY LINE INDICATING TYPE KEYS (Cont.)**

**No. 270 and No. 280 Type**

The following numbers are assigned to party line indicating keys similar in structure and design to those previously described (see code numbers 202 to 262) with the exception that they are arranged for use with No. 340 Type cam keys and therefore are provided with key tops and escutcheons of suitable dimensions to mount properly in switchboard key-shelves.

In ordering the complete party line keys consisting of push button units and cam keys, the cam keys should be specified by their proper code numbers (see No. 340 Cam Type Keys) and the number of the party line key unit also shown.

Example:

- 1 No. 283 Party Line Key Unit
- 1 No. 342-FX Cam Key
- 1 No. 341-A Cam Key

**Party Line Indicating Key Units**

Code No.	Number of Cam Keys	Type of Ringing	Size of Mounting
276	1	4 Pty. Manual	6½" x 1"
278	1	4 Pty. Manual	7¾" x 1"
279	2	4 Pty. Manual	7¾" x 1"
280	1	4 Pty. Machine	6½" x 1"
282	1	4 Pty. Machine	7¾" x 1"
283	2	4 Pty. Machine	7¾" x 1"
284	1	2 Pty. Manual	6½" x 1"
286	1	2 Pty. Manual	7¾" x 1"
287	2	2 Pty. Manual	7¾" x 1"
288	1	2 Pty. Machine	6½" x 1"
290	1	2 Pty. Machine	7¾" x 1"
291	2	2 Pty. Machine	7¾" x 1"

When the above party line indicating keys are ordered without cam keys the following code numbers should be used:

Code No.	Number of Cam Keys	Type of Ringing	Size of Mounting
277	None	4 Pty. Manual	7¾" x 1"
281	None	4 Pty. Machine	7¾" x 1"
285	None	2 Pty. Manual	7¾" x 1"
289	None	2 Pty. Machine	7¾" x 1"

Party line indicating keys and master keys are furnished with buttons of standard colors as follows:

- 4 Party Black, Green, Red, Blue
- 2 Party Red, Blue

If buttons are to be engraved complete information should be given inasmuch as plain buttons are furnished unless otherwise specified.

**No. 325—326 Type**

These are six button type master keys adapted for use as an individual master key for either five or six party line ringing. In the No. 325 Key the black button is blocked (not used) to adapt this type for five party service. The No. 326 Key is used for six party service as all buttons are operative.

The plungers in both types of keys have two positions: normal (fully restored) and the ringing position in which the keys lock and indicate. Each button remains in the indicating (locking) position until it is automatically restored when another button is depressed. Standard buttons which are black, white, blue, red and green, can be engraved as specified at an additional charge.

Depth of key from surface of escutcheon to tips of spring—3".

Stock No.	Code	Escutcheon Length	Escutcheon Width	Number of Parties	Number of Buttons
802677	(325-A)	5½"	1"	5	6
49956	(325-B)	7"	1"	5	6
49892	(325-C)	7¾"	1"	5	6
200394	(325-D)	6½"	1"	5	6
802678	(326-A)	5½"	1"	6	6
802679	(326-B)	7"	1"	6	6
49893	(326-C)	7¾"	1"	6	6
200395	(326-D)	6½"	1"	6	6

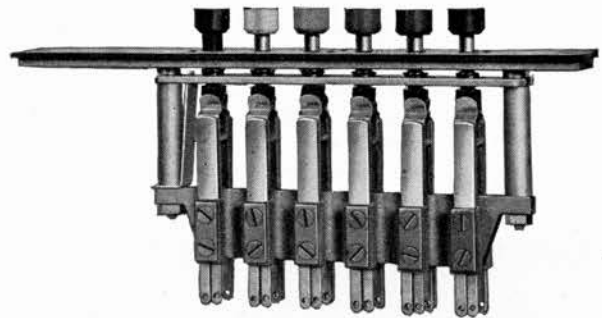

No. 325 Type Key

**Former Keys**

Many party line keys that were used in early Stromberg-Carlson switchboards can be replaced or repaired. If any such keys are not shown on these pages, our Rochester office should be consulted for information or a sample sent of the key that is needed.

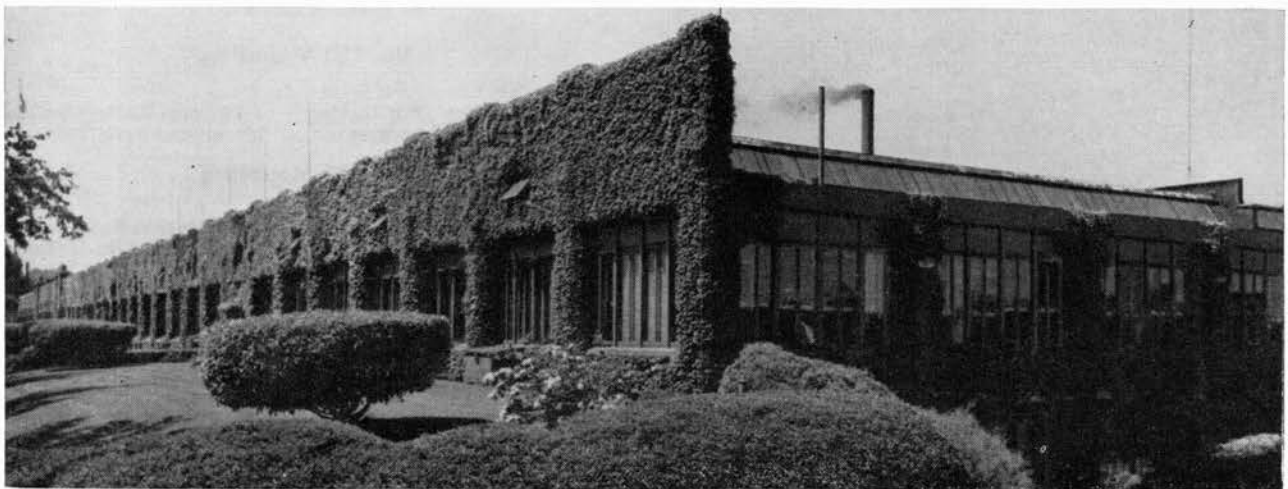

## INDIVIDUAL PARTY LINE RINGING KEYS

### No. 310 Type Key

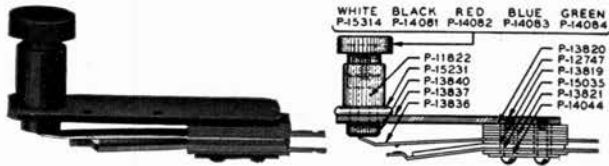

No. 310 Type Key Assembly

### No. 312 Type Key

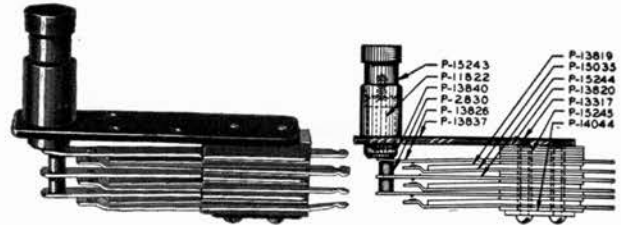

No. 312 Key Assembly

- | Stock No. | Code    | Description   |
|-----------|---------|---|
| 802490    | (310-A) | A Super-Service Non-Locking Key with one make contact for harmonic machine ringing. Mounts under key shelf—bushing protrudes through woodwork and flush with top of key shelf. Diameter of hole— $21/32$ " for clearance of push button. White button-black center. Mounts with 2 No. 11998 R.H.I.W. Screws. Specify these screws on order. Total height— $125/64$ ". Length of key over springs— $215/16$ ". Width— $3/4$ ". Diameter of button— $5/8$ ". Diameter of colored center— $31/64$ ". Designed for $7/8$ " key shelf. |
| 802491    | (310-B) | Same as No. 310-A Key, except white button, red center  |
| —         | (310-C) | Same as No. 310-A Key, except white button, blue center.  |
| —         | (310-D) | Same as No. 310-A Key, except white button, green center.   |
| 802662    | (310-E) | Same as No. 310-A Key, has plain white button.  |

- | Stock No. | Code    | Description   |
|-----------|---------|---|
| 802663    | (312)   | An Individual Non-Locking Push Button Order Wire Key for Super-Service Switchboards. Designed for mounting from under side of a $7/8$ " key shelf through a $1/2$ " drill hole flush with key shelf surface. Mounts with 2 No. 11998 R.H.I.W. Screws. Specify these screws on order. Length of key over springs— $215/16$ ". Width— $3/4$ ". Total height— $115/16$ ". Finish of button—Black. Diameter— $29/64$ ". |
| 802666    | (315-E) | Same as No. 310 except Breaks one Contact. When specified engraved buttons can be furnished at an additional charge.  |

## STRIP-MOUNTED PLUNGER TYPE KEYS

### Nos. 62 and 69 Keys

These are plunger Jack Keys consisting of push buttons assembled on hard rubber strips with mounting centers the same as used for Jacks. They are furnished in non-locking (62) and locking (69) types which have the same spring combinations and are similar in all other respects.

No. 62 and No. 69 Type Keys are used in switchboards for night switching purposes and also as circuit-restoring and ringing keys. Both types mount ten keys per strip.

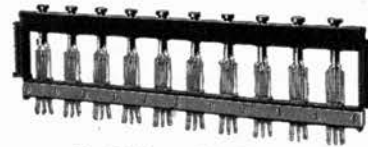

No. 62 Key on 122 Mounting

### No. 122 Mounting

Stock No.	Code	Operation	Use
42491	(62) Key	Non-Locking	2 & 6 Panel Multiple Swbds.
42980	(69) Key	Locking	Mount same as No. 130 Jacks

### No. 123 Mounting

Stock No.	Code	Operation	Use
42979	(62) Key	Non-Locking	3 & 8 Panel Multiple Swbds.
42981	(69) Key	Locking	Mount same as No. 127 Jacks

### Mounting Information

Specifications	122 Mtg.	123 Mtg.
Length of Key strip overall	$11\frac{1}{8}$ "	$8\frac{5}{16}$ "
Length of face strip overall	$10\frac{3}{8}$ "	$7\frac{19}{32}$ "
Width of face strip	$\frac{1}{2}$ "	$\frac{1}{2}$ "
Depth—face to tip of springs	$3\frac{1}{16}$ "	$3\frac{1}{16}$ "
Mounting Centers	No. 52	$47/64$ "
Jack Fasteners used	No. 17(2)	No. 17(2)
Jack blank for empty space	1"	No. 43

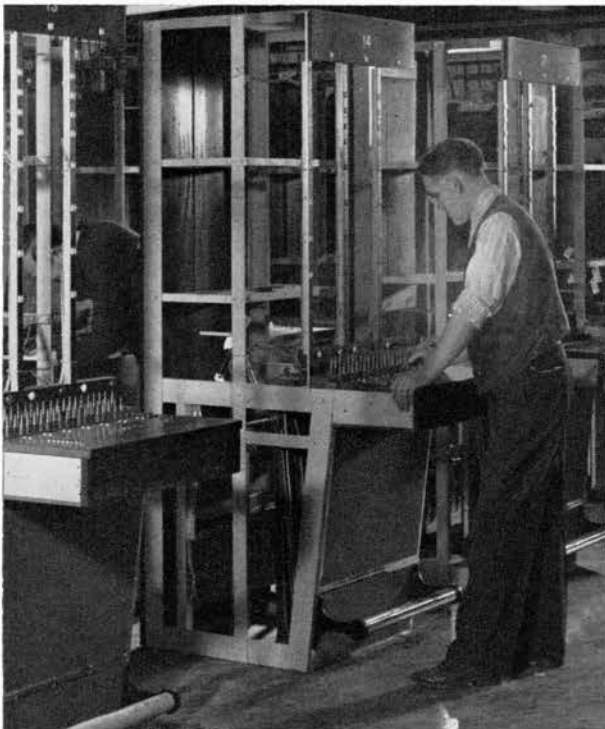

In addition to a thorough final inspection, every stage in the production of Stromberg-Carlson switchboards is carefully checked as the work progresses.

STROMBERG-CARLSON

**INDIVIDUAL PLUNGER KEYS**

**Individual Push Button Keys**



No. 303 Key

**Spring Combinations**

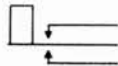

No. 303 Key  
Non-Locking



No. 304 Key  
Non-Locking



No. 305 Key  
Non-Locking

Stock No.	Code	Use
802659	(303)	Key Magneto Telephones and Desk Set Boxes, for ringing central.
802260	(304)	Key Magneto telephones for shorting lines in connection with Non-Interfering Ringing.
802261	(305)	Key No. 844 Lineman's Magneto Test Set.

Each of the above push button keys has a different spring combination but in other respects they are the same.

**Push Type and Twist Type Keys**



No. 334 Key



No. 338 Key

**Individual Push Type Plunger Keys  
Nos. 334, 335 and Nos. 336, 337**

These Keys are available in both locking and non-locking types and designed for mounting on either 7/8" or 1/2" panels. The plungers are black with plain buttons but, when specified, engraved letters can be added to meet circuit requirements. Spring contacts, method of mounting and operating features are indicated by letters affixed to the code numbers of Nos. 334, 335 and Nos. 336, 337 Type Keys.

**Individual Twist Type Plunger Keys  
Nos. 338 and 339**

Twist type keys and push type keys are the same with the exception of the plungers. All twist keys are locking. Plain black buttons are standard but red, white or brown can be furnished and engraved letters added when specified.

**Individual Push Type Plunger Keys**

Mounts on 7/8" Panel			Mounts on 1/2" Panel		
Stock No.	Code		Stock No.	Code	
49506	(334-A)	Locking	49512	(335-A)	
49507	(334-B)	Locking	49513	(335-B)	
49508	(334-C)	Locking	49514	(335-C)	
49509	(334-D)	Locking	49515	(335-D)	
49510	(334-E)	Locking	49516	(335-E)	
49511	(334-H)	Locking	49517	(335-H)	
Mounts on 7/8" Panel			Mounts on 1/2" Panel		
Stock No.	Code		Stock No.	Code	
49518	(336-A)	Non-Locking	49524	(337-A)	
49519	(336-B)	Non-Locking	49525	(337-B)	
49520	(336-C)	Non-Locking	49526	(337-C)	
49521	(336-D)	Non-Locking	49527	(337-D)	
49522	(336-E)	Non-Locking	49528	(337-E)	
49523	(336-H)	Non-Locking	49529	(337-H)	

**Individual Twist Type Plunger Keys**

Mounts on 7/8" Panel			Mounts on 1/2" Panel		
Stock No.	Code		Stock No.	Code	
49530	(338-A)	Locking	49536	(339-A)	
49531	(338-B)	Locking	49537	(339-B)	
49532	(338-C)	Locking	49538	(339-C)	
49533	(338-D)	Locking	49539	(339-D)	
49534	(338-E)	Locking	49540	(339-E)	
201122	(338-G)	Locking			
49535	(338-H)	Locking	49541	(339-H)	

- A. Two make contacts
- B. Two break contacts
- C. Two break-make contacts
- D. Two make-before-break contacts
- E. Two double make contacts
- G. Break-before-make and two breaks
- H. Four single make contacts

The Nos. 338 and 339 Twist Type are furnished only as locking keys and are used in night alarm, battery and generator switch-board circuits.

The Nos. 334, 335 and Nos. 336, 337 Push Type Keys are furnished for either locking or non-locking operation. These keys are used for signalling and in cord testing circuits.

**Former Push Type Plunger Keys**

Code	Operation	Replaced by
No. 34	Key Non-Locking	Nos. 336, 337
No. 119	Key Locking	Nos. 334, 335
No. 300	Key Non-Locking	Nos. 336, 337
No. 301	Key Locking	Nos. 334, 335

## KEY MOUNTINGS

The following Key Mountings are designed to be used with Stromberg-Carlson Keys. They are furnished in three designs—for surface keyboard mounting, for flush keyboard mounting, and for switchboard face mounting.

### Surface Keyboard Type

These Key Mountings are generally mounted with two No. 5502 Oval Head Wood Screws on the surface of keyboards. They mount one cam key each. Finish—black enamel.



No. 55

### Surface Key Mounting

Stock No.	Code No.	No. of Keys	Face Length	Face Width	Mounting Centers
†801264	(55)	1 No. 170	2 3/4"	3/4"	2 3/8"
†801270	(66)	1 No. 170	2 5/16"	3/4"	1 7/8"
		1 No. 340			
801332	(132)	or	2 3/4"	15/16"	2 3/8"
		1 No. 170			
		1 No. 340			
801333	(133)	or	2 5/16"	15/16"	1.880"
		1 No. 170			

†No. 55 and No. 66 will not mount No. 340 Type Keys.

### Flush Keyboard Type

These Mountings have steel tops covered with dull finished phenolic material and mount flush with the keyboard surface. Each mounting uses 2 No. 12908 screws and 2 No. 12672 clamps for key frame mounting. Finish dull black, except those marked\*, which are suntan.

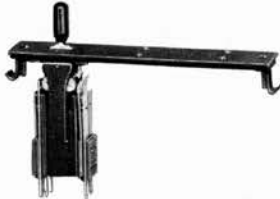

No. 88 Flush Key Mounting for one Cam Type Key

NOTE—No. 90 Key Mounting—This will mount 3 Keys and requires No. 12985 top instead of No. 12983 (one Key) or No. 12984 (Two Keys) as shown in above line drawings. Other assembly parts for the three mountings are the same.

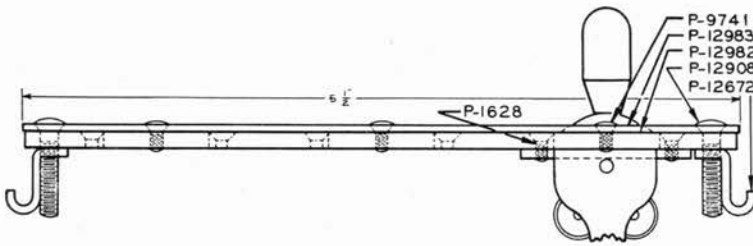

Above: Line Drawing shows Parts of No. 88 Key Mounting

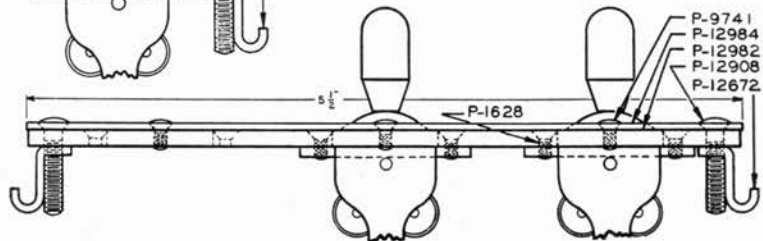

Below: Line Drawing shows Parts of No. 89 Key Mounting.

### Flush Keyboard Mountings For No. 170 or 340 Type Keys

Stock No.	Code No.	No. of Keys	Face Length	Face Width	Mounting Centers
801285	(82)	1	6 1/2"	1"	6 1/16"
801286	(83)	2	6 1/2"	1"	6 1/16"
801287	(84)	3	6 1/2"	1"	6 1/16"
801291	(88)	1	5 1/2"	1"	5 1/16"
801292	(89)	2	5 1/2"	1"	5 1/16"
801293	(90)	3	5 1/2"	1"	5 1/16"
801295	(92)	1	5 1/2"	1 1/8"	5 1/16"
801296	(93)	2	5 1/2"	1 1/8"	5 1/16"
801297	(94)	3	5 1/2"	1 1/8"	5 1/16"
801298	(95)	1	2 3/4"	1 1/8"	2 5/16"
801311	(111)	1	6 1/2"	1 1/8"	6 1/16"
801312	(112)	2	6 1/2"	1 1/8"	6 1/16"
801313	(113)	3	6 1/2"	1 1/8"	6 1/16"
801314	(114)	1	7 1/4"	1 1/8"	6 13/16"
801315	(115)	2	7 1/4"	1 1/8"	6 13/16"
801316	(116)	3	7 1/4"	1 1/8"	6 13/16"
†801319	(119)	3	5 1/2"	3/4"	5 1/16"
801321	(121)	1	2 3/4"	1"	2 5/16"
801325	(125)	1	7"	1"	6 1/2"
801326	(126)	2	7"	1"	6 1/2"
801327	(127)	3	7"	1"	6 1/2"
*801328	(128)	1	5 1/2"	1"	5"
*801329	(129)	2	5 1/2"	1"	5"
*801330	(130)	3	5 1/2"	1"	5"
*801331	(131)	3	5 1/2"	7/8"	5"
801334	(134)	1	5 1/2"	1"	5 1/16"
801335	(135)	1	6 1/2"	1"	6 1/16"
801336	(136)	2	6 1/2"	1"	6 1/16"
801337	(137)	3	6 1/2"	1"	6 1/16"
*_____	(138)	1	5 1/2"	7/8"	5 1/16"
*_____	(139)	2	5 1/2"	7/8"	5 1/16"

\*These Key Mountings have Suntan finish escutcheons and use Phillips head brass screws for face mounting.

†No. 119 will mount No. 170 Type Keys only.

### Switchboard Face Mounting Type

These Key Mountings mount similarly to jacks and lamps in the faces of switchboards. They are held in place by No. 17 Jack Fasteners. Finished in black enamel.



No. 120 Switchboard Face Key Mounting

Stock No.	Code No.	No. of Keys	Face Length	Face Width	Mounting Centers
801294	(91)	10	10 3/8"	1 1/2"	11 1/16"
801304	(104)	5	10 3/8"	1 1/2"	11 1/16"
801320	(120)	10	10 3/8"	2"	11 1/16"

**NO. 13 KEY BOX**



No. 13 Key Box

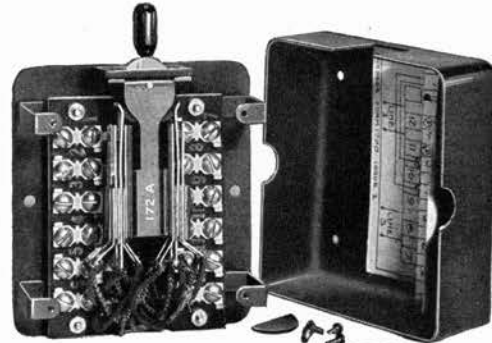

No. 13 Key Box—Open

The Stromberg-Carlson No. 13 Key Box is another revenue producer for the operating company. It makes possible better and additional telephone service, and is particularly useful in

- A. Aiding Extension Telephone Service.
- B. Grouping of Telephone Lines for Secretarial Supervision.
- C. Operating Call Signals.
- D. Tying Low Voltage Circuits Together.
- E. Switching Loud Speakers in Paging Service.
- F. Sending Code Signals in No. 2-6 Systems.

The No. 13 Key Box is made of pressed steel in a dull black finish. It is designed for mounting on the side or end of a desk or table. Each Key Box is equipped with one cam type Key.

All key springs are wired to screw terminals in such a manner that various wiring combinations can readily be made. Dimensions— $4\frac{1}{4}$ " x  $3\frac{3}{8}$ " x  $1\frac{7}{8}$ ".

**No. 34575 Key Box (Less Key and Wiring)**

When keys other than those shown in the following codes are required, they may be selected from those listed under "Cam Keys". These keys may be mounted in the No. 34575 Key Box (less key and wiring). Twelve terminals are provided within each Key Box.

Stock No.	Code	Equipped Former Key with	Description
801226	(13)	343-A Key (172-A)	2-Way, Locking-Locking
801227	(13-A)	343-B Key (185-A)	2-Way, Locking-Locking
801228	(13-B)	340-A Key (179-A)	1-Way, Locking
801229	(13-C)	341-A Key (178-A)	1-Way, Non-Locking
801230	(13-D)	340-C Key (188-A)	1-Way, Locking
801231	(13-E)	343-A Key (172-A)	2-Way, Locking-Locking
801232	(13-F)	343-E Key (318-A)	2-Way, Locking-Locking
800091	(13-FA)	343-Q Key	2-Way, Locking-Locking
*800094	(13-G)	345-A Key	1-Way, 3 position lock'g

\*No. 345-A Key, used in the No. 13G Key Box, has a tilted handle. All other keys have straight handles.

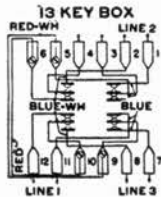

Wiring Diagram No. 13 Key Box

With No. 343-A Locking Key

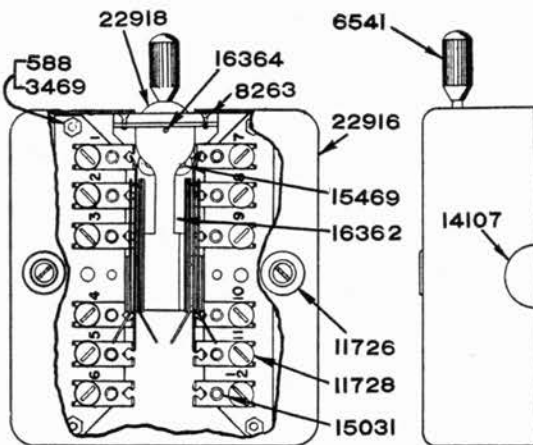

Line Drawing showing arrangement of Terminals and Key. In No. 13 Key Box Assembly Part Numbers are also shown.

**Typical Wiring Diagrams of No. 13 Type Key Boxes**

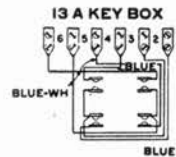

With No. 343-B Locking Key

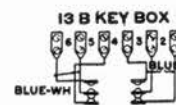

With No. 340-A Locking Key

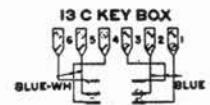

With No. 341-A Non-Locking Key

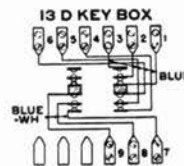

With No. 340-C Locking Key

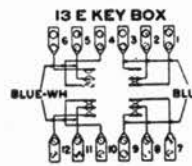

With No. 343-A Locking Key

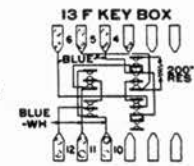

With No. 343-E Locking Key

## TYPICAL NO. 13 KEY BOX APPLICATIONS

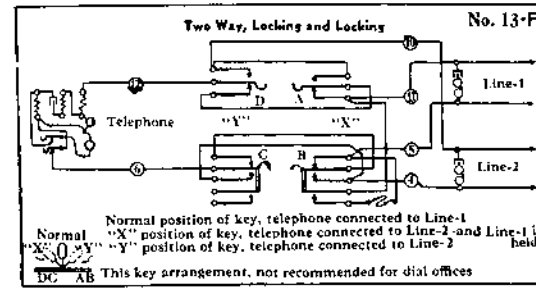
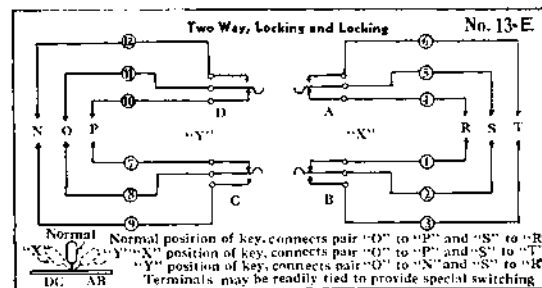
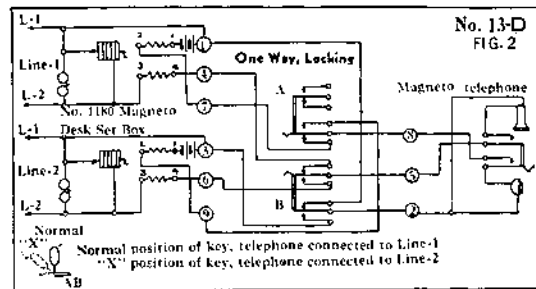
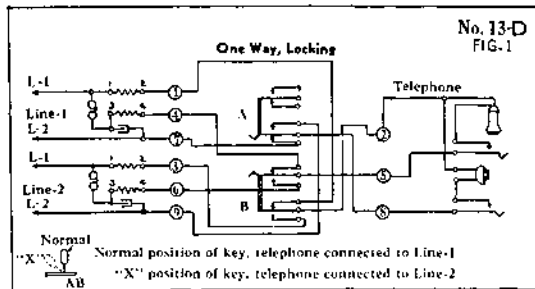
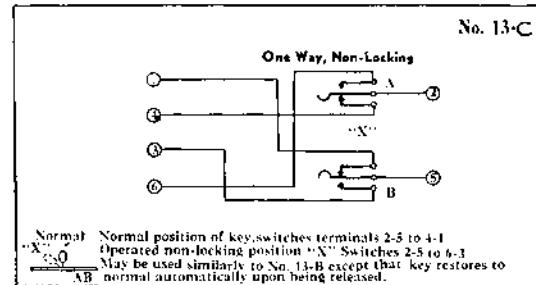
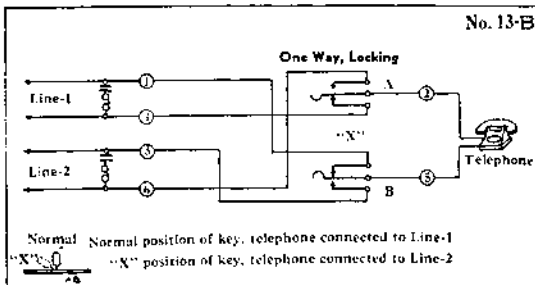
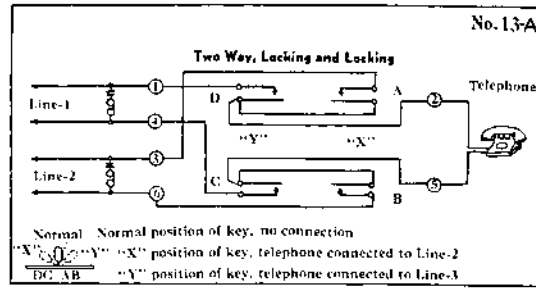
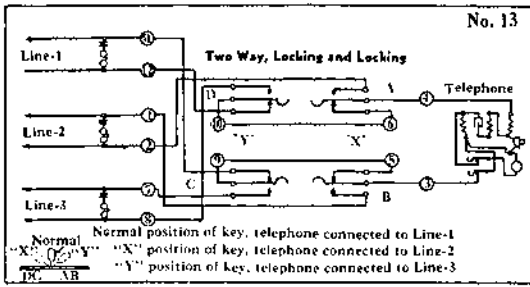

**CARD FRAMES**

Stock No.	Code	Use	Description
801350	(2)	Mounts subscriber's number on No. 7 Type Transmitter.	Construction — Steel, black enameled frame holding white bristol-board with transparent celluloid protector. Length—2 15/32". Width—29/32".
801351	(3)	Mounts operator's instruction cards on No. 101 PBX Switchboards and on toll boards.	Construction — Brass frame with japanned semi-gloss black finish, holding card with glass protector. Length—3 1/4". Width—2 11/16".



No. 2 Card Frame

Stock No.	Code	Use
801352	(4)	Card Frame used on No. 1201 and 1232-3-4 suspended type Handset Telephones.
24557	—	Card Frame used on 1197 Handset Telephones.

**LAMPS—SWITCHBOARD**

Stromberg-Carlson tipless lamps have a service record which justifies their reputation for being dependable and economical under actual operating conditions.

Their use is not limited as these lamps will fit any standard lamp socket in telephone service.

The over all length is 1 23/32" and diameter 0.300". Put up in standard packages of 100 lamps but smaller quantities may be ordered.

**Important Advantages**

Tungsten filaments clamped to the lead-in wires.

Filament supports of highly heat-resistant material are embedded in the stem.

Base consists of two metal contact pieces on either side of a plastic insulator of extremely high dielectric strength.

Long life and low current consumption is enhanced by using special stem glass that is nine times more resistant to heat than ordinary glass.

The use of acid-free solder and special plating of contacts maintains solid electrical contacts for years.

The elapsed time between hot and cold resistance of one-fifth of a second is practically negligible.

Operation through a maximum range of voltage with minimum fluctuation of signal value.

The filament is mounted near the end of the bulb to obtain maximum end-on candle power at the tip of the lamp.

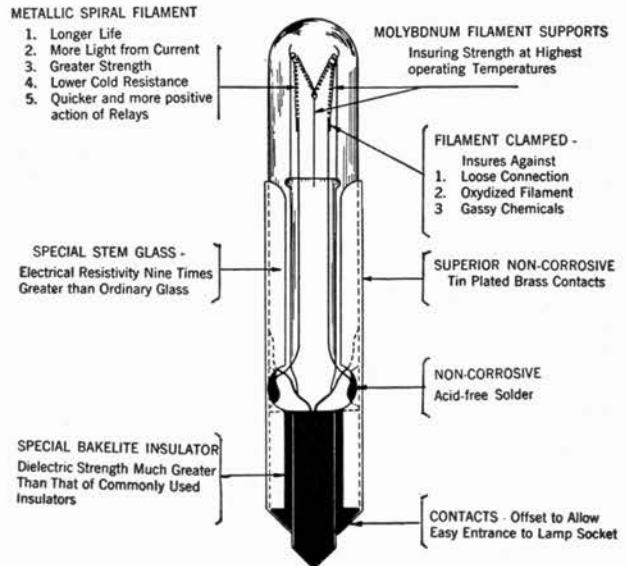

Stromberg-Carlson Telephones Switchboard Lamp

**Ordering Data and Characteristics**

Stock No.	Code	Voltage	Current Consumption Amperes		Approximate Cold Resistance	Aver. *End Foot Candle Power
			Min.	Max.		
801363	(4-A-2)	4	.170	.210	2.0	135
801364	(6-A-2)	6	.120	.160	4.5	225
801365	(8-A-2)	8	.080	.100	9.0	250
801366	(12-A-2)	12	.090	.110	12	295
801367	(16-A-2)	16	.090	.110	16	340
801369	(24-B-2)	24	.035	.050	61	140
801370	(24-C-2)	24	.060	.085	33	535
801371	(30-B-2)	30	.090	.110	30	490
801372	(44-A-2)	44	.060	.085	61	630
801374	(48-B-2)	48	.090	.110	48	600
42201	(48-C-2)	48	.034	.038	185	145
801375	(55-C-2)	55	.045	.055	104	425
45271	(60-A-2)	60	.045	.055	113	525

\*E.F.C. is the candle power at a distance of one foot from the tip of the lamp.

24 volt lamps may be used on voltage 18-28.

44 volt lamps may be used on voltage 36-48.

48 C-2 lamp may be substituted for former 44-B-2.

## LAMP CAPS

Stromberg-Carlson Lamp Caps are built to combine neatness with durability—the lenses are made of specially annealed glass to resist breakage from impact with plugs, and are mounted in bushings made from seamless metal tubing which is later spun over to retain the lenses—other end of shank is slotted for close fitting in lamp socket.

### No. 23 Pilot Type



No. 23 Pilot Lamp Cap

A pilot lamp cap used on common battery multiple, non-multiple, and PBX Switchboards. Designed for use with the No. 9 Individual Lamp Socket. This lamp cap is equipped with an attractive sand-blasted lens. Maximum diameter of face— $59/64$ ", Diameter of shank is  $0.811$ ", fits  $13/16$ " hole.

Stock No.	Code	Color	Lens Finish	Glass Description
801388	(23-A)	White	Glossy	Translucent
801389	(23-B)	Red	Sanded	Translucent
801390	(23-C)	Green	Sanded	Translucent
801391	(23-D)	Amber	Sanded	Translucent

### No. 27 Supervisory Type

A Supervisory Lamp Cap associated with trunk circuits, with cord circuits, and with miscellaneous circuits where caps are not required to be numbered. Designed for use with the No. 12 Lamp Socket on the keyboard and the No. 121 Lamp Socket on Nos. 79, 80, 81 or 82 Mounting in the switchboard face. This lamp cap is equipped with a non-breakable opal. Maximum diameter of face— $3/8$ ", Diameter of shank— $0.340$ ", fits  $11/32$ " hole.



No. 27 Supervisory

Stock No.	Code	Color	Lens Finish	Glass Description
801392	(27-A)	White	Glossy	Cloudy
801393	(27-B)	Red	Sanded	Clear
801394	(27-C)	Green	Sanded	Clear
801395	(27-D)	Transparent	Glossy	Clear
801396	(27-E)	White	Glossy	Cloudy, Red when lighted

### No. 29 Line Type



No. 29 Line

Associated with line lamp sockets in 20 per strip mounting on eight panel multiple switchboards. Designed for use with the No. 121 Lamp Socket on No. 83 Mounting only. Equipped with a non-breakable lens. No. 29-A only provided with removable number disc which is held in place by an invisible ring. Disc numbered as specified. Maximum diameter of face— $3/8$ ", Diameter of shank— $0.320$ ", fits a  $5/16$ " hole.

Stock No.	Code	Color	Lens Finish	Glass Description
801400	(29-A)	Transparent	Glossy	Clear, number disc
801401	(29-B)	Red	Sanded	Clear
801402	(29-C)	Green	Sanded	Clear
801403	(29-D)	White	Glossy	Cloudy
801404	(29-E)	White	Glossy	Cloudy with • Symbol
801405	(29-F)	White	Glossy	Cloudy with + Symbol
801406	(29-G)	White	Glossy	Cloudy with   Symbol

### No. 30 Line Type

A lamp cap used on PBX and Multiple Switchboards over line lamps. Designed for use with the No. 121 Lamp Socket on Nos. 79, 80, 81, 82, or 89 Mountings. Equipped with a non-breakable lens. No. 30-A and 30-L only provided with removable paper number disc which is held in place by an invisible ring. Disc numbered as specified. Diameter of face— $3/8$ ", Diameter of shank— $0.340$ ", fits a— $11/32$ " hole.



No. 30 Line

Stock No.	Code	Color	Lens Finish	Glass Description
801407	(30-A)	Transparent	Glossy	Clear, number disc
801408	(30-D)	White	Glossy	Cloudy with • Symbol
801409	(30-J)	White	Glossy	Cloudy with + Symbol
801410	(30-K)	White	Glossy	Cloudy with   Symbol
801411	(30-L)	Transparent	Flat lens with number disc.	



No. 30-D No. 30-J No. 30-K Lamp Caps

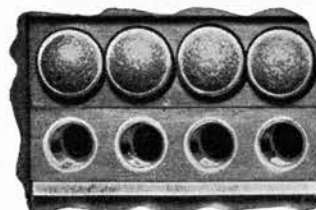

No. 30 Line Type, Mounted and associated with line jacks

### No. 31 Supervisory Type

Standard lamp cap used with both trunk and cord circuits on PBX and Multiple Switchboards. Designed for use with the No. 13 Lamp Socket only. Equipped with a non-breakable lens. Maximum diameter of face— $13/32$ ", Diameter of shank— $0.343$ ", fits  $11/32$ " hole.



No. 31 Supervisory Lamp Caps

Stock No.	Code	Color	Lens Finish	Glass Description
801412	(31-A)	White	Glossy	Translucent
801413	(31-B)	Red	Sanded	Translucent
801414	(31-C)	Green	Sanded	Translucent

**LAMP SOCKETS**

Stromberg-Carlson Lamp Sockets are furnished in two types: those for mounting individually and those for mounting in strips. Both of these types are provided with all metal frames so as to readily distribute and radiate the heat generated by the lamps. Every Stromberg-Carlson Lamp Socket with the exception of Code Nos. 10, 11, and 14, takes a standard switchboard lamp and lamp cap. Code Nos. 10, 11, and 14 Lamp Sockets take Edison Base Lamps.

Lamp Sockets which are mounted in strips for use in the face of switchboard align with jacks having the same type of mounting.

Mounting screws, fasteners, lamps and lamp caps are not included with the lamp sockets, but should be ordered separately.

**Individual Lamp Sockets  
Pilot Type**

For pilot lamp service on PBX and Multiple Switchboards. Used with standard switchboard lamps and the No. 23 Lamp Cap. Mounts on the face of the switchboard in any standard panel with two No. 6176 Wood Screws. Consists of steel frame with brass head for lamp cap; equipped with insulating fiber tubing and nickel silver springs. Length overall—2 15/16". Diameter of head—7/8". Diameter of sleeve—7/16".



No. 9 Lamp Sockets

Stock No.	Code	Used with
801417	(9)	Lamp Socket No. 23 Lamp Cap (Pilot)

**No. 12 Supervisory Type**

Used on PBX and Multiple Switchboards for supervisory lamp service. Consists of a steel frame with a fiber tubing for insulating purposes and nickel-silver springs. Mounts on the under surface of any standard—7/8" key shelf with one No. 4 x 1/2" R.H.I.W. Screw. Takes standard switchboard lamp and the No. 27 Lamp Cap. Length over springs—2 7/16". Diameter of sleeve—7/16". Mounting lug—11/16" from face.



No. 12 Lamp Socket

Stock No.	Code	Used with
801420	(12)	Lamp Socket No. 27 Lamp Cap (Supervisory) Replaced by No. 13 on all new work

**No. 13 Supervisory Type**

A standard lamp socket for cord circuits and supervisory lamp service. Replaces the No. 12 and used on all new work. Used on PBX, Multiple, and Super-Service Switchboards. Consists of a steel frame with a fiber tubing, for insulating purposes, and nickel-silver springs. Mounts from the under surface of any standard—7/8" panel with one No. 4 x 1/2" R. H. I. W. Screw. Takes standard switchboard lamp and the No. 31 Lamp Cap. Length over springs—2 29/32". Diameter of sleeve—1/2". Mounting lug—27/32" from face.



No. 13 Lamp Socket

Stock No.	Code	Used with
801421	(13)	Lamp Socket No. 31 Lamp Cap (Supervisory)

**Generator Protection Type**

Mounted lamp sockets designed to take resistance lamps for generator protection, used in multiple switchboards where party ringing service is required. Strip fastened to the roof of the switchboard with four No. 10 x 3/4" R.H.I.W. Screws. Consists of a white shellacked maple mounting strip equipped with Porcelain Edison Base Lamp Sockets, No. 4 Cord Terminals and steel supports for mounting.



No. 10 Lamp Socket

Stock No.	Code	No. of Sockets	Used with
801418	(10)	Lamp Socket 4	Edison base lamps
801419	(11)	Lamp Socket 5	Edison base lamps
801420	(14)	Lamp Socket 6	Edison base lamps

**Face Strip Type**

No. 121 Lamp Sockets with mountings 59, 60, 61 and 67 were used on Stromberg-Carlson Switchboards made previous to 1917. Used only on additions to old S-C installations on two, three, four, and six panel multiple sections in connection with the No. 109 Type Jack. Takes standard switchboard lamp and No. 30 Individual Lamp Cap. Consists of face plate, mounting extensions, and sleeve sockets—all made of steel with black enamel finish. Equipped with nickel-silver springs. Sleeve socket insulated from springs with black tubular sheet fiber.



No. 121 Lamp Socket on 59 Mounting

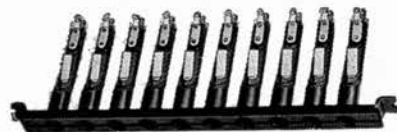

No. 121 Lamp Socket on 67 Mounting

Length of face—10 15/32", Overall length—11 15/32", Width of face—1/2", Mounting Centers—10 15/32", Face Length—7 37/64", Jack Fasteners—No. 15.

Stock No.	Code	No. of Sockets	Description
801430	(121)	Lamp Socket Strip 5	Plain face
801431	(121)	Lamp Socket Strip 10	Plain face
801432	(121)	Lamp Socket Strip 20	Plain face
801433	(121)	Lamp Socket Strip 10	Plain face

## LAMP SOCKETS (Cont.)

### Face Strip Type (Cont.)

No. 121 is a Standard Lamp Socket for two, three, four and six panel associated multiple and PBX Switchboards. Used in connection with the No. 130 Type Jacks and mounts the same. Replaces Garford Type. Takes standard switchboard lamp and No. 27 or No. 30 Individual Lamp Cap. Consists of a face plate, lugs, and sleeve sockets—all made of steel with black enamel finish. Equipped with nickel-silver springs. Sleeve sockets insulated from springs with black tubular sheet fiber.



No. 121 Lamp Socket on 80 Mounting

Length of face— $10\frac{3}{8}$ " , Overall length— $10\frac{3}{4}$ " , Width of face— $\frac{1}{2}$ " , Mounting Centers— $11\frac{1}{16}$ " , Jack Fastener—No. 17.

Stock No.	Code	Mounting	No. of Sockets	Description
801423	(121)	79	5	Plain Face
801424	(121)	80	10	*Plain Face
801425	(121)	81	20	+Plain Face

\*Can also be drilled for No. 26 Lamp Cap when specified.  
 †Can also be drilled for No. 25 Lamp Cap when specified.



No. 121 Lamp Socket on 82 Mounting

No. 121 Eight Panel Multiple Switchboard Lamp Socket, used in connection with No. 127 Type Jacks. Replaces Garford Type. Takes standard switchboard lamp, and the No. 30 Individual Lamp Cap. Similar to the No. 79 Mounting only shorter and mounts 10 sockets per strip on  $\frac{3}{4}$ " centers.

Length of face— $7\frac{19}{32}$ " , Overall length— $5\frac{31}{32}$ " , Width of face— $\frac{1}{2}$ " , Mounting Centers— $8\frac{3}{8}$ " , Jack Fastener—No. 17.

Stock No.	Code	Mountings	No. of Lamp Sockets	No. of Lamp Caps
801426	(121)	Lamp Socket Strip	82	10 No. 30
801429	(121)	Lamp Socket Strip	*89	10 No. 30

\*No. 89 replaces No. 82 on new work.  
 Lamp sockets on above mountings are also drilled for No. 24 Twin Type Lamp Caps.

No. 121 Eight Panel Multiple Switchboard Lamp Socket used on all new work in connection with the No. 127 Type Jack. Takes standard switchboard lamp, and the No. 29 Individual Lamp Cap. Consists of black molded face strip with satin finish on face, sheet steel frame for mounting the springs, and the two end lugs. Equipped with nickel-silver springs.

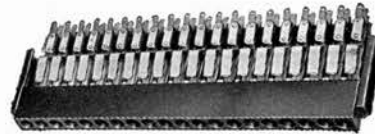

No. 121 Lamp Socket on 83 Mounting

Length of face— $7\frac{19}{32}$ " , Overall length— $7\frac{31}{32}$ " , Width of face— $\frac{1}{2}$ " , Mounting Centers— $8\frac{3}{8}$ " , Jack Fastener—No. 17.

Stock No.	Code	Mountings	No. of Description Sockets
801440	(121)	Lamp Socket Strip	91 10 Plain face
801427	(121)	Lamp Socket Strip	83 20 Plain face
801439	(121)	Lamp Socket Strip	92 20 Takes No. 26 Designation Strip

## NUMBER PLATES



No. 13 Number Plate



No. 19-A Number Plate

Number Plates—used on jack stiles to designate subscriber's multiple; on plug boards to designate cord circuits; on keyboards to designate keys; and on power boards to designate switches.

- 7005 (13) A round number plate, used on wood drop mounting panels, keyboards, terminal strips, etc. Consists of white opaque celluloid engraved with black figures— $\frac{1}{8}$ " high. Mounts flush—drive fit. Diameter— $\frac{1}{4}$ ". Thickness— $\frac{3}{16}$ ".
- 9573 (17) Round number plate used on plug boards and keyboards, associated principally with the No. 310-E Key on Super-Service Switchboards. White, opaque, plain or engraved with figures or letters— $\frac{3}{16}$ " high. Mounts flush—drive fit. Diameter— $\frac{7}{16}$ ". Thickness— $\frac{5}{16}$ ".
- 15373 (17-A) Same as No. 17 except Black.
- 15374 (17-B) Same as No. 17 except Red.
- 15375 (17-C) Same as No. 17 except Blue.
- 15376 (17-D) Same as No. 17 except Green.
- 13062 (19-A) Square number plate used on multiple finishing stiles. Consists of white ivory with black engraved figures—style to be specified. Three figures or less— $\frac{7}{32}$ " high, four or more  $\frac{9}{64}$ ". Mounts with 2 No. 12910 O.H.M. Screws. Size— $1\frac{1}{16}$ " square. Thickness— $\frac{7}{64}$ ".
- 13063 (19-B) Same as No. 19-A except Red Ivory.

**OPERATOR'S TELEPHONE SETS**

**No. 4 Type with Breast Plate Transmitter**



No. 4 Operator's Telephone Set

The No. 4 Operator's Telephone Set consists of a breast plate transmitter with a neck band, a light weight receiver, a four conductor Duratex cord, and a four point plug. It offers the following desirable features:

Transmitter embodies the most modern design to give distinct and clear articulation. It is mounted on a white enameled plate which prevents garments from being soiled and is equipped with adjustable neck band to maintain the transmitter at proper height. A ball and socket joint at transmitter opening makes it possible to keep the mouthpiece in correct relation to the operator's lips. Transmitter operates equally well with common battery or magneto switchboard circuits. Sensitive Receiver, light in weight, enables the operator to wear it for long periods without fatigue—equipped with wire head band which holds it firmly and comfortably to the operator's ear.

Duratex Cord with bronze ribbon conductors which reduces scratching and noise to a minimum.

Rugged Plug uses four separate conductors which provide low resistance circuit contacts—easily removed from the jack.

Stock No.	Code	Description
801453	(4)	Operator's Set complete

**Parts of No. 4 Operator's Set**

Stock No.	Code	Description
802523	(21)	Breast Plate Transmitter complete
801592	(29)	Headband Receiver
201839	(66)	Four-Point Plug (Takes No. 93 Jack)
201829	(MO-4-K)	5' 4-cond. Duratex Cord
13483		Neckband and clasp
5419		Mouthpiece

NOTE: Earlier No. 4 Type Operator's Sets were equipped with MO-4-F, 5' Cords and No. 23 four-point plugs which are not interchangeable with the new MO-4-K, 5' cord and No. 66 4-point Plug that are now used.

**Parts of Earlier Type Operator's Sets**

Description	Common Battery Set		Magneto Set	
	No. 2-C	No. 3-C	No. 2-L	No. 3-L
Breast Plate Transmitter	18-C	18-CW	18-L	18-L
Headband Receiver	20-A	29	20-A	29
Oper. Plug (Four-Point)	23	23	23	23
Oper. Cord (Four Cond.)	MO-4-C	MO-4-F	MO-4-C	MO-4-F
Neckband and Clasp	13483	13483	13483	13483
Mouthpiece	5419	5419	5419	5419

NOTE: Plugs for Nos. 2, 3 and 4 Operator's Sets all take No. 93 4-Point Operator's Jack.

Transmitters, receivers and plugs are separately shown in this section.

**Suspended Type Operator's Sets**

This set consists of No. 22 Universal Type Transmitter with mouthpiece and front molded in a single unit and No. 29 Headband Receiver.

For switchboard use the transmitter is suspended by two single conductor cords from an adjustable arm mounted on top of the cabinet.

Stock No.	Code	Description
802525	(22)	Operator's Transmitter (Suspended)
801592	(29)	Headband Receiver (Less Cord)
202926	(MO-2-J)	4', two conductor cord

This outfit uses the No. 66 Four-Point Plug to match the No. 93 Jack which is standard for all switchboards. Only two conductors, however, are actually needed for suspended operator's sets.

## PLUGS

Stromberg-Carlson Plugs are equipped with bronze tip conductors to withstand wear; special alloy steel tip rods for strength; best quality tough, hard rubber for insulation; and heavy black fibre shells for protection. The tip rods are threaded through and spun over the end of the tip conductor.

Three conductor plugs, Code Nos. 53, 54, and 65 Types are equipped with bronze dead rings to protect the insulation between the tip and ring conductors.

Plug screws for both terminals and shells are drilled for pilot screw driver.

Order plugs by stock and code number. If this is impossible, send in a sample plug or state serial number of switchboard on which the plugs will be used.

No extra charge is made for attaching cords to plugs when the order includes both plugs and cords.

### Designations

"X" affixed to code number indicates over-all shell covering butt of plug.

"N" affixed to code number indicates non-depressed ring.

Diameters shown in illustrations indicate size of associated jack.

### Switchboard Plugs Two Conductor Plugs



No. 10 Plug

No. 42 Plug

Stock No.	Code	Used with	Class of Service
801465	(10)	34, 101 102 Jack	Manually restored drops and toll test panels. Uses S-23-G Two Conductor Cord
801481	(42)	11 Drop	No. 105 Magneto Switchboard. Uses S-23-G Two Conductor Cord



No. 56 Plug

No. 56-X Plug

Stock No.	Code	Used with	Class of Service
801495	(56)	130 Jack	Replaces No. 5060 Plug on Garford Magneto Swbds. Uses S-22-F Two Conductor Cord.
801497	(56-X)	130 Jack	No. 125 Magneto Switchboard. Also PBX and Multiple Boards. Uses S-22-F Two Conductor Cord.



No. 57 Plug

No. 61 Plug

Stock No.	Code	Jack used	Class of Service
801498	(57)	109	Replaces No. 36. Former common battery and PBX Switchboards. Uses S-22-B Two Conductor Cord
801502	(61)	144-A, 145-A, 154-A, 155-A	Toll test panels Uses S-24-K Two Conductor Cord Interchangeable with W.E. No. 47

### Three Conductor Switchboard Plugs



No. 54 Plug

No. 55 Plug

Stock No.	Code	Used with	Class of Service
801488	(54)	127 Jack	Common battery multiple swbds. Uses S-32-K three conductor cord
801489	(54-D)	127 Jack	Same as No. 54 except ring diameter. Uses S-32-K three conductor cord
801492	(54-N)	Garford 110, and 120 Jacks	Same as No. 54 but with non-depressed ring. Uses S-32-K three conductor cord.
801493	(55)	109 Jack	Common battery multiple swbds. Uses S-32-K three conductor cord.
801494	(55-N)	109 Jack	Same as No. 55 but with non-depressed ring. Uses S-32-K three conductor cord.
801504	(63)	109 Jack	Same profile as No. 55. Uses W.E. 101 Cord Tips. Uses S-32-P three conductor cord.
801505	(63-N)	127 Jack	Same as No. 63 but with non-depressed ring. Uses S-32-P three conductor cord.
801506	(64)	156, 157 and 127 Jacks	Same profile as No. 54. Uses W.E. 101 Cord Tips. Uses S-32-P three conductor cord.
801511	(64-N)	Garford 110, and 120 Jacks	Same as No. 64 but with non-depressed ring. Uses S-32-P three conductor cord.



No. 59 Plug

801500	(59)	145, 154, 155	Toll test panels Uses S-33-NS Three Conductor Cord Interchangeable with W.E. No. 110
--------	------	---------------------	--

### Replaced No. 53 Type Plug

The No. 53 Three-Conductor Plug, formerly used with Stromberg-Carlson No. 130 Jack and Garford No. 3210 and No. 4260 Types, has been replaced by and is interchangeable with the No. 65 Plug. The cords, however, are not interchangeable.

When cords are required for No. 53 Plugs in service, S-32-K of required length should be used instead of the cord for the No. 65 Plug.

### No. 65 Switchboard Plug

Stock No.	Code	Used with	Cord Used
202079	(65)	130 Jack	S-32-P (Three conductor)
*202080	(65-X)	130 Jack	S-32-P (Three conductor)
202081	(65-N)	130 Jack	S-32-P (Three conductor)
202082	(65-NX)	130 Jack	S-32-P (Three conductor)

\*Used on Stromberg-Carlson PBX and Multiple Switchboards. Black shells are standard but red and gray shells can also be furnished. For Stock Numbers of shells see heading "Plug Parts".

PLUGS (Cont.)

Test Plugs

These plugs are used in connection with toll test panels and wire chief's testing equipment at the M.D.F.

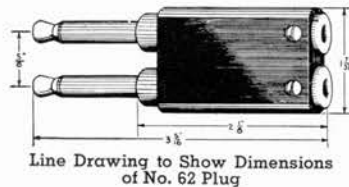
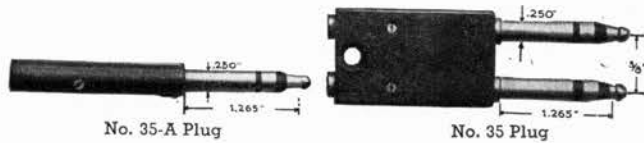

Stock No.	Code	Conductors	Used with	Class of Service	Cord Used
801477	(35)	6	101 Type Jack	Test Panel	M-6-D
801476	(35-A)	3	101 Type Jack	Test Panel	S-32-K
801503	(62)	4	154 Type Jack	Test Panel	M-4-C

No. 66 Operator's Plugs

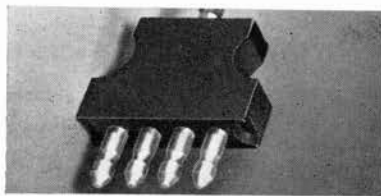

No. 66 Operator's Plug

The No. 66 Four-Point Operator's Plug is used in connection with the No. 93 Jack, on all Stromberg-Carlson Switchboards. All four points of the No. 66 Plug and associated jack are used with operator's sets having breast plate transmitters.

In the case of operator's with suspended type transmitters only two conductors of the No. 66 Plug are used as the receiver and transmitter cords are separate. This has proved to be a most convenient arrangement as it permits the use of either breast plate or suspended type operator's sets without any additional apparatus or wiring.

Stock No.	Code	Jack used	No. of Points	Cord Used	Operator's Set Used
201839	(66)	93	4	MO-4-K, 5'	No. 4 B.P. Type
201839	(66)	93	2	MO-2-J, 4'	Susp. Type

Former Operator's Plugs  
For Suspended Type Sets

Code No.	Size	Associated Apparatus Used			Cord
		Jack	Receiver	Transmitter	
23 Plug*	4-Point	93	29	8-C or 8-L	MO-2-I
23 Plug*	4-Point	93	20-A	8-C or 8-L	MD-2-B
40 Plug	2-Point	58	29	8-C or 8-L	MO-2-H
40 Plug	2-Point	58	20-A	8-C or 8-L	MO-2-F

\*Only 2 Points are used.  
NOTE: "C"—Common Battery, "L"—Magneto.

For Breast Plate Transmitter Sets

Code No.	Size	Associated Apparatus Used			Cord
		Jack	Receiver	Transmitter	
23 Plug	4-Point	93	29	18-C or 18-L	MO-4-F
23 Plug	4-Point	93	20-A	18-C or 18-L	MO-4-C

No. 60 Outlet-Box Plug

This is used with wall-outlet jack outfit consisting of outlet box and brass plate with plug-in jack assembly.

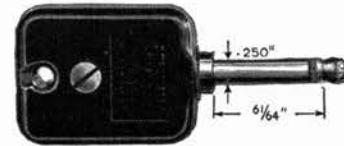

No. 60 Plug

For a description of this complete assembly refer to this section (F) under "Individual Jacks."

Stock No.	Code	Jack Used	Description
801501	(60)	2-Point	Used with No. 25856 Plug-in Jack Assembly

Plug Parts

Plug Code No.	Shell Stock No.	Shell Screws Stock No.	Terminal Screws Stock No.
10	8851	5729	5729
35	6911	4836	8300
35-A	12836	4836	8300
42	8339	13061	5729
53, 53-N	25045(a)	4836	8300
53-X, 53-NX	13060(b)	13061	8300
54, 54-N	25045(a)	4836	8300
55, 55-N	25045(a)	4836	8300
56	25045(a)	4836	5729
56-X	13060(b)	13061	5729
57	25045(a)	4836	5729
59	14033	14695	14693

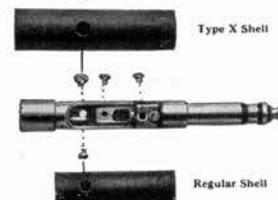

Plug Parts

Plug Code No.	Shell Stock No.	Shell Screws Stock No.	Terminal Screws Stock No.
60	15148(2)	15147	515020
61	21421	21420	21419
61-A	22321(c)	21420	21419
62	26853	26854	21419
63, 63-N	34405(d)	4836	4836
64, 64-N	34405(d)	4836	8300
65, 65-N	202076(e)	4836	8300
65-X, 65-NX	35296(f)	13061	8300

- (a) These shells are black. Specify 15319 for red shell. Specify 15578 for gray shell.
- (b) These shells are black. Specify 27584 for red shells. Specify 27585 for gray shell.
- (c) No. 61-A Plug has red shell. No. 61 plug has black shell.
- (d) These shells are black. Red shell is 34406. Gray is 34407.
- (e) These shells are black. Red shell is 202078. Gray is 202077.
- (f) These shells are black. Red shell is 35297. Gray is 35298.

## PLUGS (Cont.)

### Plug and Jack Gauges

These gauges should be in every telephone exchange. They indicate when plugs and jacks are worn to an extent that talking connections will be unreliable.

When a plug passes through the slot in the plug gauge it should be replaced.

If the jack gauge fits into the jack, the jack should be replaced.

Each set includes one plug and one jack gauge with a canvas carrying case.



Jack Gauge



Plug Gauge

Stock No.	Diameter	Description
13070	.246	Plug Gauge
13071	.255	Jack Gauge
52236		Carrying Case

The equipment listed above is used to gauge Nos. 10, 31, 35, 40, 42, 53, 55, 56, 57, 63, 65 Plugs and Nos. 5, 11, 49, 58, 101 and 130 Jacks, and No. 11 Drop Jack.

Stock No.	Diameter	Description
13114	.217	Plug Gauge
13118	.226	Jack Gauge
52236		Carrying Case

The equipment listed above is used to gauge Nos. 39, 54, 64 Plugs; and Nos. 22 and 127 Jacks.

Stock No.	Diameter	Description
13113	.197	Plug Gauge
13119	.205	Jack Gauge
52236		Carrying Case

The equipment listed above is used to gauge Nos. 33, 34 Plugs and No. 67 Jacks.

### Plug Seats

Plug seats are furnished with two wood screws for attaching to the under side of plug boards. The center hole is chamfered to prevent injury to the cords while passing through this opening. The Nos. 5, 6 and 12 Plug seats are the same except for the diameter of the center hole which varies according to the size of the plug that is used.



No. 5 Type



No. 6 Type

Stock No.	Code	Plug Used	Diam. Hole	Material	Mtg. Screws
4637	(5)	10, 42, 59, 61	11/32"	Fiber	2-No. 3939
4638	(6)	53, 54, 55, 56 57, 63, 64, 65	5/16"	Fiber	2-No. 3939
12170	(12)	18, 33, 34, 39	1/4"	Fiber	2-No. 3939

### Service Plugs

Service plugs are available in standard colors for use as party-line indicators and out-of-service indications to the operator. They are made of brass with spread shanks that can be adjusted to firmly plug into the jack openings.

The No. 7 Type is used to indicate four-party lines by using service plugs of different colors in holes that are drilled around the jack.

The No. 14 and 15 Types (used as out-of-service indicators) are inserted directly into the line jacks in place of plugs.



No. 7 Type



No. 14 Type



No. 15 Type

Stock No.	Code	Stock No.	Code	Stock No.	Code
801526	(7-A)	801531	(14-A)	801537	(15-A)
801527	(7-B)	801532	(14-B)	801538	(15-B)
801528	(7-C)	801533	(14-C)	801539	(15-C)
801529	(7-D)	801534	(14-D)	801540	(15-D)
801530	(7-E)	801535	(14-E)	801541	(15-E)
802769	(7-F)	801536	(14-F)	—	—

Above code letters indicate the following colors:

A—Green	C—Blue	E—Black
B—Red	D—White	F—Yellow

Type No.	Diameter Service Plug	Fits Jack No.	Used as
7	.070	*109-130	Party Line Indicators
14	.195	122-127	Out-of-Service Indicators
15	7/32"	109-130	Out-of-Service Indicators

\*When drilled for 4-Party Lines

### Plug Hole Blanks

Blanks that are used to fill the space of switchboard plugs and individual lamp sockets. This improves the appearance of the switchboard and prevents dust from settling in unequipped openings.



A Typical Plug Hole Blank

Stock No.	Code	Material	Shank Diameter	Plug Used
1294	(1)	Composition	.500	10, 42, 53-X, 56-X
7637	(6)	Composition	.406	53, 54, 55, 56, 57, 63, 64, 65
12713	(7)	Rubber	.347	No. 12 Lamp Socket
21672	(12)	Composition	.610	No. 61 Plug

### Plug Trouble Caps (Sleeves)

These are black fiber tubes that are split full length so as to slip over plugs of various diameters. Trouble sleeves are used to designate cord circuits that are temporarily out of service.

Stock No.	Code	Name	Length	Plugs Used
16582	(1)	Trouble Cap	1 1/8"	54, 64
16583	(2)	Trouble Cap	1 1/8"	10, 42, 53, 55, 56, 63, 64, 65
16584	(3)	Trouble Cap	1 1/8"	33, 34

**RECEIVERS**

**No. 29 Operator's Receiver**

The No. 29 Head-Band Receiver is a component part of the No. 4 Operator's Breast Plate Telephone Set described in this section (F) under Operator's Telephone Sets.

This receiver is also used with suspended type operator's sets in connection with the No. 22 Transmitter which is suspended from an adjustable arm mounted on the roof of the switchboard cabinet. This is also shown under Operator's Telephone Sets.

All Stromberg-Carlson Switchboards are equipped with No. 93 four-point operator's Jacks. All four conductors are used for No. 4 Breast Plate Sets but only two conductors for the headband receivers when associated with suspended type transmitters.



No. 29 Operator's Receiver

A watch case receiver using silicon steel coil cores for high efficiency, and chrome alloy steel magnets to insure a definite and permanent magnetic field. The magnet and cores are held firmly in place by clamps to prevent the possibility of variation between pole pieces and diaphragm. Two coils, each wound to 65 Ohms provide a total resistance of 130 Ohms. Equipped with a sanitary, light weight, wire head band.

**Parts for No. 29 Operator's Receiver**

**For Suspended Operator's Sets**

Stock No.	Code	Description
801592	(29)	Receiver with head band (Less Cord)
203046	29)	Receiver with Cord (For No. 66 Plug)
202926	(MO-2-J)	4' Cord only (Two conductor)
45367	(29)	Receiver with Cord (For No. 23 Plug)*
800646	(MO-2-I)	6' Cord only (Two conductor)

\* The No. 23 Plug and No. 66 Plug which replaces it are interchangeable but each requires a different cord as shown above.

**For Breast Plate Operator's Sets**

Stock No.	Code	Description	Plug Used	B.P. Set Used
801592	(29)	Headband Rcvr (less cord)	No. 66	No. 4
201829	(MO-4-K)	5' Four Conductor Cord	No. 66	No. 4
800640	(MO-4-C)	5' Four Conductor Cord	No. 23	No. 2-C, 3-C
800645	(MO-4-F)	5' Four Conductor Cord	No. 23	No. 2-L, 3-L

**Other Parts**

Stock No.	Name	Used on
19279	Headband	No. 29 Receiver
18583	Ear Cap	No. 29 Receiver
21433	Diaphragm	No. 29 Receiver

**Former Operator's Receivers**

The No. 20-A Receiver and Cord has been replaced by the No. 29 Receiver with MO-2-1, 6' Cord for No. 23 four-point operator's plug and by the No. 29 Receiver with MO-2-H, 6' Cord for No. 40 two-point operator's plug which has been discontinued. Both the No. 23 and No. 40 Plugs were used with replaced suspended type operator's sets.

**No. 20-A Receiver Parts**

Stock No.	Description	Code No.	Description
9578	Headband	MD-2-B	6' Cord (No. 23 Plug)
15190	Ear Cap	M-0-2F	6' Cord (No. 40 Plug)
9924	Diaphragm		

**Sub-Station Receivers**

**No. 30 Type**

This receiver is used with old style wall sets and desk stands which have been generally superseded by the more modern handset telephones in either wall or desk types.

Stock No.	Code	Name	Used with
*801593	(30)	Receiver	Wall Sets and Desk Stands
801594	(30-A)	Receiver	Wall Sets and Desk Stands
801595	(30-B)	Receiver	Iron-Clad Telephones

\*The No. 30 Receiver is furnished without cord.

**Assembly Parts**

Stock No.	Code	Name	Receiver Used
800655	(MR-2-J)	39" Cord	No. 30-A
800627	(M-2-I)	22" Cord	No. 30-B
33179		Casing	No. 30-A, 30-B
32864		Earcap	No. 30-A, 30-B
34230		Capsule Unit	No. 30-A, 30-B

The No. 30 Type Receiver is encased in a plastic shell and ear cap which covers a capsule unit that is firmly held in place by pressure contacts. The spool is assembled with a non-metallic head to prevent eddy current losses and wound with high grade enameled copper wire.

The construction is simple and durable and years of service will not impair the highly efficient receiving qualities that are assured.



No. 30 Receiver

## RECEIVERS (Cont.)

### Handset Receivers

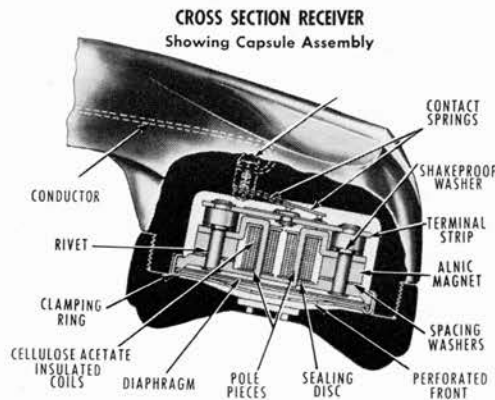

#### No. 34230 Capsule Type

This self-contained capsule type unit is used exclusively in the No. 20 Series Handsets with which all current types of common battery and magneto handset telephones are equipped.

This design, therefore, eliminates the possibility of loose connections and consequent receiver distortion. Further dependability is assured by the use of selected materials as a protection against the damaging effects of excessive humidity.



Permanent circuit connections are made simply by dropping this capsule unit into a recess in the handset handle where two circular contacts engage separate spring points. The solid connections that are made in this way will remain intact regardless of the position of the handset.

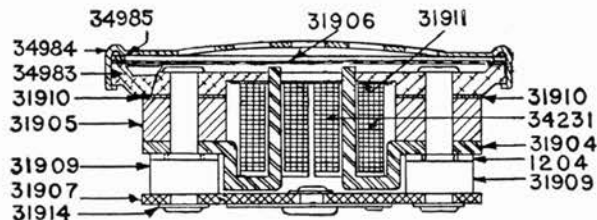

Line Drawing No. 34230 Capsule Receiver

#### No. 19-A Watchcase Receiver

A permanent magnet receiver with two coils connected in series. Approximate total resistance 100 Ohms. Used with Stromberg-Carlson No. 844 Lineman's Test Set.

Stock No.	Code	Description
801588	(19-A)	Watchcase Receiver—Less Cord
800626	(M-2-J)	24" Cord
15190		Ear Cap
9924		Diaphragm

#### Former Handset Receivers

Stock No.	Name	Type	Ear Cap	Handset Used
*23167	Receiver	Non-Capsule	23162	15, 16, 17
34242	Receiver	Non-Capsule	34364	15, 16, 17

\*No. 23167 with No. 23162 Ear Cap is interchangeable with the later No. 34242 Receiver with No. 34364 Ear Cap.

Both of the above types were used in Nos. 15, 16, and 17 old style handsets with metal inserts into which the receivers were threaded.

#### Former Sub-Station Receivers

##### Nos. 27-A and 27-B

The No. 27-A Receiver was formerly used with Desk Stands and Wall Telephones with steel or wood cabinets and the No. 27-B with Iron-Clad Telephones for underground or out-of-door use.

When complete sub-station receivers are needed the No. 30 Capsule Type should be ordered inasmuch as this receiver, as a complete unit, is interchangeable with the No. 27 which is no longer manufactured.

Parts are available, however, for the No. 27 Receiver and these may be selected from the following list.

#### Receiver Replacement Parts

Stock No.	Code	Used on
800652	(MR-2-G)	36" Cord
800627	(M-2-1)	22" Cord
13370	Casing	27-A, 27-B Receiver
13371	Ear Cap	27-A, 27-B Receiver
9924	Diaphragm	27-A, 27-B Receiver

RELAYS AND RELAY COILS

The relays listed in this Catalogue are adapted for use in telephone communication, signalling, and remote control circuits. By combining standard spring combinations and coils an endless variety of assemblies may be had, covering a wide range of characteristics, operating voltages, and contact arrangements for both direct current relays and alternating current relays.

In designing Stromberg-Carlson Relays particular care has been taken to incorporate features which will meet specific requirements. Line relays are made compact and sensitive, while cord circuit relays are built to carry several easily adjusted spring combinations with contacts that are plainly visible.

Ordering Information

When ordering relays for Stromberg-Carlson Switchboards the number of the circuit in which they are used should always be shown. This information is required for adjusting current flow values which should be the same as originally determined to assure uniform operation.

If unable to specify the code number in ordering relays, provide the following information on such points as apply to the particular item you desire. This information is necessary to properly edit factory orders.

1. Kind of operating current—Direct or Alternating—state frequency.
2. Operating voltage or current.
3. Single, tandem, or concentric winding.
4. Resistance, if known.
5. Quick or Slow Acting.
6. Continuous or Periodic Operation.
7. Number and type of spring combinations.
8. Amount of current contacts must carry and whether inductive or non-inductive.
9. Type of mounting and casing desired.

No. 190 Type Relays

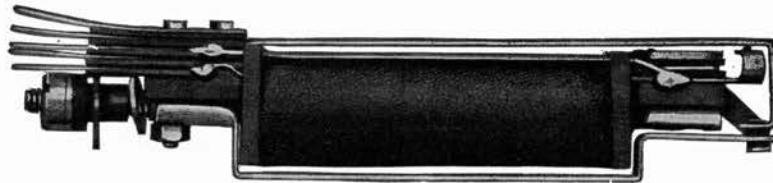

No. 190 Type Relay (Actual Size)

The No. 190 Type of Relay is used in line circuits—for both PBX and Multiple Switchboards. This type relay's outstanding features are:

**HIGH EFFICIENCY**—The very high efficiency of this relay is obtained by combining the armature and the traveling contact spring into one element. This construction requires less magnetic effort for operating contacts in telephone circuits. The efficiency of this relay is further increased by fastening the armature rigidly and metallicly to one end of the relay's core.

**COMPACTNESS**—But one-third to one-half of the space is required for this relay that is required for other types of relays. Obviously, this compactness permits closer mounting centers which means a marked saving of space either in the switchboard section or on the relay racks in the terminal room.

**LIGHT WEIGHT**—This relay is the lightest in weight of any of the standard relays, which means easier handling during installation and less danger of the relay's breaking loose from its mounting during shipment.

**ACCESSIBILITY**—All contacts are at the extreme front end, easily inspected, easily adjusted, and easily tested, even when the relays are mounted on the closest possible centers.

**RELIABILITY**—Owing to simplicity of construction, the use of high grade materials, and careful manufacture, this relay is unsurpassed for reliable operation. Many exchanges completely equipped with No. 190 Type Line Relays report that relay trouble is negligible and that relay casings are seldom removed. This reliability is due to the following conditions:

1. The armature construction does not permit binding or getting out of alignment.
2. The phenolic spool heads and spring insulations provide good insulation that is neither hygroscopic nor affected by temperature changes.
3. The windings are of the best grade of commercially pure, heavily enameled copper wire.

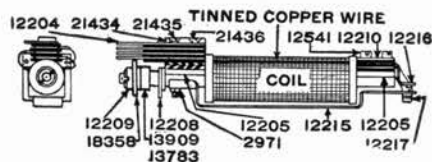

Parts Drawing of No. 190 Type Relay

Stock No.	Code	Approx. Ohms Resistance	Spring Arrangement	Stock No. Coil only
802774	(193-BB)	320	Two breaks	12234
802775	(194-A)	800	One make	12235
802776	(194-C)	800	One break-make	12235
802777	(195-A)	320-1000 N.I.	One make	12265
200580	(197-BB)	34	Two breaks	19075
802950	(198-A)	400 x 400	One make	21587
802778	(199-BB)	320	Two breaks	12234

Under the heading "Relay Casings" dust proof covers are shown that will accommodate groups of 20, 40 or 50 No. 190 Type Relays.

## RELAYS AND RELAY COILS (Cont.)

### No. 200 Type D.C. Relays

The No. 200 Type Relay is especially designed for circuits requiring:

1. Several windings
2. Large winding spaces
3. High impedances
4. Diversity of spring combinations
5. Timing of relay's action

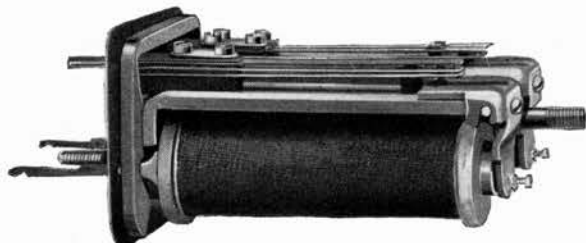

Two No. 200 Type Relays mounted on Relays Casing Support

The features of this relay are:

- Efficient Magnetic Circuit.
- Pin-pivoted, definitely located armature of the "L" shaped type.
- Adjustable residual screw in armature.
- Facilities for the quick removal of the relay's coil.
- Visible contacts located at the front end of the relay.
- Phenol fibre spring insulation.
- Coils with formica heads.

#### How to Order No. 200 D.C. Type Relays

The scheme for coding No. 200 Type Relays provides for assigning group numbers for the various styles of windings, viz.: "single wound," "tandem wound," "concentric wound," "slow release," and "slow operating." These numbers are followed by letters indicating the spring combination desired. (See table of Relays Less Springs for code numbers used and diagrams for spring combinations.)

#### Examples

##### Code No. 205-AB Relay

This specifies a single wound relay, 200 ohms resistance, (see table for single wound relays) having springs with one make contact (A) and one break contact (B).

##### Code No. 242-CC Relay

This specifies a concentric wound relay, 1000 ohms inductive and 100 ohms non-inductive, (see table for concentric wound relays) having two sets of break-make contacts.

The number indicates the resistance and type of winding; the letter or letters indicate the spring combinations.

All Stromberg-Carlson relays use a phenolic head and have no freeze on end of core. (Formerly indicated by letter Z in code.)

When coils are to be equipped with anti-wear pins, "W" should follow the code number of relay; for example: 205 W.

The No. 200 Type Relay may be furnished with 1, 2, or 3 sets of spring combinations which will be mounted in alphabetical order from left to right looking at the terminal end of the relay—except for relays with 3 spring combinations having 2 combinations alike, then the odd combination shall be mounted in the middle.

#### Spring Designations

Standard spring combinations are designated by affixing the following letters to "200 Type" relay code numbers which indicate style of winding and resistance only.

- \*A One make
- \*B One break
- \*C One break-make
- D One make before break
- EY One double make
- FY One break and double make
- G One break and make before break
- \*H Two makes
- K Two breaks
- L One make and one break
- \*M One break-make and one make
- \*N One break-make and one break
- O One make before break and one make
- PY One break and double make
- \*Q One make and one break (sequence)
- R One break-make, heavy contacts
- TY One double make, heavy contacts
- U Make before break and delayed break

#### Light (Y) Springs

\*These combinations can also be furnished with light springs by adding the letter "Y" to the letters of the regular spring combinations, as: AY, BY, CY, HY, MY, NY, QY

#### No. 200 Type D.C. Relays

The following Stromberg-Carlson relay parts do not include spring combinations.

Springs as required must be specified with the Code No. when complete relays are desired. Coils only, are shown under their proper Stock Numbers.

#### Single Wound Coil

Code No.	Relays Less Springs Approx. Ohms Resistance	Coil only Stock No.
201	5	12276
202	15	12277
203	70	12278
204	100	15491
205	200	12280
206	500	12266
207	1000	12267
208	800	12281
209	1500	12282
210	5000	12283
212	18-50 N.I.	30005
213	320	15435
214	2000	15436
215	16-75 N.I.	Copper Core 32846
*285	500	15434

\*Replaced by No. 206 on new work.

#### Slow Release, Single Coil with Copper Sleeve

Code No.	Relays Less Springs Approx. Ohms Resistance	Coil only Stock No.
261	100	*15429
262	200	*15430
263	500	*15431
264	1000	*15432
265	50	*15433
266	23	*202167
267	5000	*202453

\*Copper sleeve over core.

**RELAYS AND RELAY COILS (Cont.)**

**No. 200 Type D.C. Relays (Cont.)**



Tandem Wound Coils

**Tandem Wound Coils**

Tandem coils have a rear winding (1-2) which is at the terminal end and an adjacent front winding (3-4) which is at the armature end.

**Two Inductive Windings (Tandem)**

Code No.	Relays Less Springs Approx. Ohms Resistance	Coil only Stock No.
221	65-65 Balanced Inductance	12286
222	100-100 Balanced Inductance	12287
223	200-200 Balanced Inductance	12288
224	500-500	12289
225	1000-1000	12290
226	50-50 Balanced Inductance	12291
227	100-250	12292
228	75-75 Balanced Inductance	12293
229	200-2000	12294
231	500-1000	12295
232	400-400	12296

**Concentric Wound Coils**

The first winding (1-2) of concentric coils is next to the core, and the second winding (3-4) is on the outside.

**One Inductive—One Non-Inductive Winding (Concentric)**

Code No.	Relays Less Springs Approx. Ohms Resistance	Coil only Stock No.
241	500-100 N.I.	12297
241-1	200-350 N.I.	33856
242	1000-100 N.I.	12298
242-1	200-1000 N.I.	33857
243	100-350 N.I.	15197
243-1	1000-500 N.I.	37012
244	500-350 N.I.	15198
245	500-2000 N.I.	15199
246	100-60 N.I.	15200
247	100-1000 N.I.	15201
248	500-500 N.I.	15202
249	1000-1000 N.I.	29743



Concentric Wound Coils

**Two Inductive Windings (Concentric)**

Code No.	Relays Less Springs Approx. Ohms Resistance	Coil only Stock No.
251	500-1000	15203
251-1	500-1000 (A.C. Relay)	39351
252	500-100	15204
252-1	13-2000	42782
253	200-500	15205
254	175-2100	17809
254-1	500-5000	202006
255	100-10,000 (Takes AY Spring)	15207
255-1	250-2000	203192
256	250-500	15208
257	250-670	15209
258	500-500	15210
259	100-200	15211
295	200-75	28366
296	500-75	28365
297	1000-75	28367
298	340-2000	32845
299	1000-150	38507

**Slow Operating Type Relays With Concentric Wound Coil**

**One Inductive—One Non-Inductive Winding**

Code No.	Relays Less Springs Approx. Ohms Resistance	Coil only Stock No.
291	500-100 N.I.	*15219
292	500-450 N.I.	*33757
293	500-3000 N.I.	*33855

\*Have copper sleeve on core.

**Slow Release Type Relays With Concentric Wound Coil**

**One Inductive—One Non-Inductive Winding**

Code No.	Approx. Ohms Resistance	Coil only Stock No.
276	500-100 N.I.	*202007
277	500-2000 N.I.	*202008
278	500-10,000 N.I.	*202009
279	50-1000 N.I.	*201174

\*Have copper sleeve on core.

**300 Type Relay**



No. 300 Type Relay

This relay which mounts the same as the No. 200 Type, is especially designed for actuating contacts, without vibration, when alternating, pulsating or superimposed ringing current is used.

The No. 300 Type Relay can be furnished either separately as a non-locking relay or as a ring up locking relay when associated with a No. 200 Type Relay having the letter "X" affixed to the Code number.

## RELAYS AND COILS (Cont.)

### No. 300 Type Relays (Cont.)

The following spring combinations for No. 300 Type non-locking and locking relays are standard:

Non-Locking	Locking
A--One make	X--One make lock with armature
B--One break	*AX--One make and one locking armature make
C--One break-make	*BX--One break and one locking armature make
AA--Two makes	*CX--One break-make and one locking armature make
BB--Two breaks	
CC--Two break-makes	

\*Locking relays with these "X" springs are used only in connection with No. 200-X Relays.

NOTE: The letter "X" denotes a make contact and locking device actuated by the attraction of the armature which is restored by the operation of an associated No. 200-X Type Relay.

#### Example

- 1 - No. 306-AX Relay consisting of:  
 1 - No. 306 Coil (500 Ohms) and frame  
 1 - "AX" Spring Combination

#### Associated With

- 1 - No. 204-BBX Relay consisting of:  
 1 - No. 204 Coil (100 Ohms) and frame  
 1 - "X" Armature  
 1 - "BB" Spring Combination

#### No. 300 Type Relay

Code No.	Relays Less Springs Approx. Ohms	Winding	Coil Only Stock No.
306	500	Single	15220
307	1000	Single	15221
313	400-500	Concentric	15222

Above Code numbers cover coils of designated resistances and relay frames only. To make complete relays, springs should be added to meet requirements.

#### No. 320 Type Relay

This relay has been replaced by the No. 300 Type. It was formerly used as a ring up or drop relay on magneto lamp line circuits and consisted of two interacting relays—one actuated by alternating and the other by direct current.

#### No. 340 Type Relay

A polarized type relay which is used in cases where reversal of battery polarity is required for signalling purposes. These relays are especially sensitive to low currents.

The No. 340 Type Relay has two coils and mounts the same as two No. 200 Type Relays. Furnished only with the following spring combinations:

Code No.	Resistance		Spring Combination	Coil Only Stock No.
	Total	One Coil		
343-CC	500	250	Two break-make	13086
*344-C	500	250	One break-make	13086
*345-C	20,000	10,000	One break-make	35036
*346-C	174	87	One break-make	35405
347-C	20,000	10,000	Two break-make	35036
348-CC	30,000	15,000	Two break-make	201028

\*These relays have contacts insulated from the armature. They can be wired for "A" (one make), "B" (one break) or "C" (one break-make) Spring Combination.

### No. 360 Type Relay

This relay, like the No. 300 Type, is adapted for use with alternating, pulsating or superimposed ringing. Unlike the "300" Relay, however, the No. 360 Type has an adjustable armature loaded with a copper weight. This relay is equipped with an "A" (make) spring combination.

Code No.	Spring Combination	Resist. Ohms	Operation	Coil Only Stock No.
366-A	One make	500	Non-Locking	15220
367-A	One make	1000	Non-Locking	15221

### No. 370 Type

This type includes the No. 371 Relay which has been discontinued and replaced by No. 202919. Designed for toll circuit operation.

### No. 375 Type Relay

This is a concentric wound relay designed primarily for use with universal cord circuits. A quad coil is used consisting of three inductive and one non-inductive winding of the following resistances:

Code No.	Resistance Ohms	*Spring Combination	Coil only Stock No.
375-W	75-175-700-2200 N.I.	-----	28414
376-WCYBY	75-175-700-2200 N.I.	One break-make One break	28414
377-WCYCY	75-175-700-2200 N.I.	Two break-make	28414
378-W	150-225-700-2200 N.I.	-----	38506
379-WCY	150-225-700-2200 N.I.	One break-make	38506
385-WFYCY	75-175-400-400 N.I.	One break and double make; One break-make	200375

NOTE: The letter "W" indicates that these relays are equipped with anti-wear pins.

\*Center spring combination should be specified in ordering this type of relay.

Code Number	Resistance	Stock No.
386-W	100-100, 700-200 NI	203405 Coil
*387-W	200-200, 700-200 NI	203404 Coil
388-W	100-100, 700-200 NI	203405 Coil
*389-W	200-200, 700-200 NI	203404 Coil

\*These coils have the same windings but different armatures.

### No. 380 Type Relay

This type of relay is used in line and supervisory pilot circuits or in any other places where high sensitivity is essential. A micrometer screw adjustment assures accuracy and when used for supervisory purposes the transmission loss is extremely low.

Stock No.	Code	Coil No.	Resistance
803103	(381-A)	44356	*1.7 Ohms

\*Plus or minus 10%.

### No. 202919 Type Relay

Stock No.	Resistance		Spring Combination
	Total	Per Coil	
202919	3200	1600	Break-Make

A relay designed for toll circuit operation and equipped with two coils.

## A AND B TYPE RELAYS

These relays are designed to meet the exacting requirements of telephone switching systems. The A and B relays were subjected to many severe tests before the complete design was approved and only after it had been actually demonstrated that this apparatus would meet every field condition that might be encountered. In addition, life tests were run over millions of cycles of operation, cycles of temperature ranging from  $-40^{\circ}$  F to  $150^{\circ}$  F and cycles of relative humidity exceeding 90%. Vibration tests were also made, similar to those applied to aeronautical equipment.

New processes of production have been developed which provide maximum spring stability and at the same time easier and more permanent contact adjustment. Spring combinations and coils have been standardized which increase the supply of available parts to facilitate deliveries of these items as well as the complete equipments with which they are used. Although exhaustive tests indicate long life, reliability and trouble-free operation,

there may be cause for occasional relay adjustments in the field. Some operating conditions are more severe than average and some relays in a system are subject to considerably more wear than others. For these reasons particular care has been taken to develop a design that permits easy removal of functional parts and any adjustment that may be necessary for perfect operation.

### "A" Type Relays

The "A" Type is a general-purpose telephone relay used in XY Systems or in other places where similar operating conditions exist. This relay will give reliable service under ordinary conditions or in damp climates, due to the use of carefully selected insulating materials and special treatment to prevent failures caused by electrolysis and corrosion.

#### The Frame

The plated frame increases bearing life by preventing corrosion and at the same time makes an attractive finish. This frame, together with the core and armature form an efficient magnetic circuit of the conventional telephone-relay type. The coils are designed to withstand the most unfavorable climatic conditions and cellulose acetate insulation is used at all points coming in contact with the wire. The wire, itself, is carefully inspected for quality and uniformly highgrade insulation. The core is threaded and securely attached to the frame of the relay by means of a nut which permits easy removal of the coil.

#### The Armature

The armature is L-shaped and designed so as to operate on a knife-edge pivot. It is held in place by a non-adjustable spring retainer that is welded to the frame. This retainer rests on the axis of rotation of the armature which permits it to move with the least possible friction without interfering with its easy removal. With this method of construction side play is virtually eliminated. The armature travel is adjusted by means of an armature support which also acts as a stiffener to prevent distortion and any lost motion at the spring contacts. The spring combinations are mounted in two stacks, one on the right side and the other on the left side of the spring mounting plate. The top clamping plate bridges and covers both spring stacks which provides great mounting stability as well as over-all mechanical protection to the springs. Spring combinations of "A" Type Relays may also be mounted in one stack. The equivalent of 12 "make" contacts may be mounted on each "A" Type Relay although this number may be increased to 18 when sufficient mounting space is available. Bar type twin contacts of pallad-

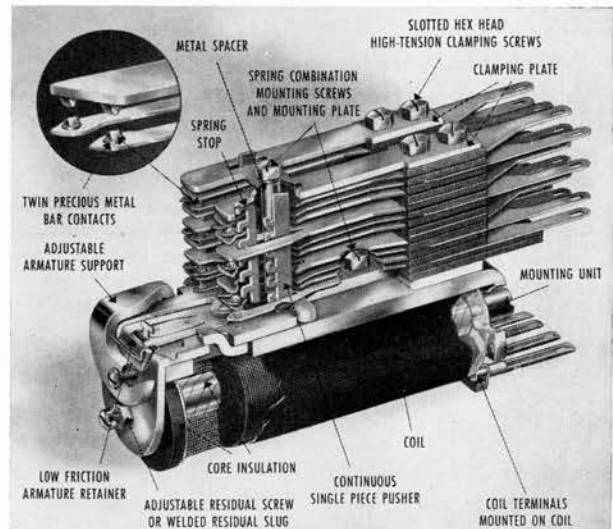

"A" Type Relay

ium are carried by two tines on each spring, which assures un-failing operation. Stability of contact adjustment is maintained by a rigid mechanical arrangement in which the heavy stationary springs are properly located by a stepped phenolic spring stop. This stop and associated springs are supported by a clamping plate which is securely attached to the relay frame by a mounting screw and metal spacer. This construction holds the heavy springs firmly in position at a point near the contact end and gives the whole pile-up greater stability.

#### The Spring Pushers

A continuous single-piece spring pusher of phenolic material permits each moving spring to operate individually as a cantilever beam. This unimpeded action reduces friction and prevents one spring from interfering with the proper operation of other springs in the pile-up.

## A AND B TYPE RELAYS (Cont.)

### Basic Spring Combinations

Four basic spring combinations are used with the "A" Type Relay. These combinations, known as "A," "B," "C," and "D," are as follows:

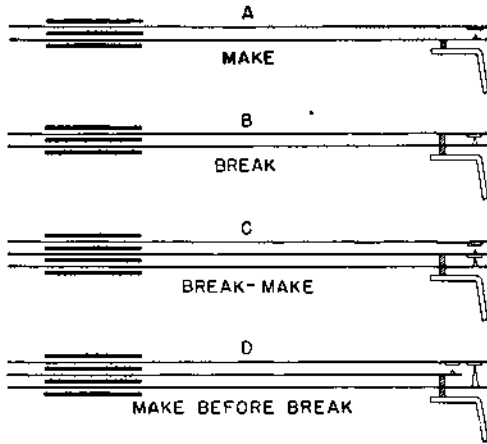

Types of "A" Relay Coils

#### 1. Coils for Quick-Acting Relays

- (a) Single wound coils. A large percentage of telephone relay coils are of this type. "A" Type Relays using these coils normally have quick operation and release characteristics.
- (b) Concentric double-wound coils. These windings are placed one over the other, using the full length of the coil.
- (c) Parallel wound coils. Both windings of these coils are applied at the same time, paralleling each other from the beginning to the end of the winding operation.

#### 2. Coils for Slow-Releasing Relays

These coils have a copper collar attached at the terminal end to retard the dying away of the magnetic pull when current is removed from the winding.

#### 3. Coils for Slow-Operating Relays

These coils are fitted with a copper collar at the armature end of the coil to retard the building up of the magnetic field. This has the effect of delaying armature action.

#### 4. Coils for Slow-Acting Relays

In making slow acting coils a 1/2" copper sleeve is placed over the entire length of the core which delays the operation of the armature when current is applied. This construction also retards the dissipation of the magnetic field when current is removed, which causes a delay in the release of the armature.

### Special Relays

Normal requirements can usually be met by a broad use of the standardized groups of coils and spring-pile-ups that are provided for "A" Type Relays in tables that follow. For example, it is more economical to select a spring combination with one or two more springs than are actually needed or a coil of approximately the required resistance instead of using a special relay that exactly conforms to specifications that are not standard. Special relays can be made, however, when quantities involved are large enough to make a good manufacturing proposition. In such cases our engineers will be glad to cooperate in the proper selection of relay units when sufficient information is provided about the circuits employed and operating conditions to be met.

### Basic Spring Combinations For Pile-Ups in A Type Relays

A—Make B—Break C—Break-Make D—Make-before-Break

Xa—Indicates preliminary operating "Make" contact

Xc—Indicates preliminary operating "Break-Make" contact

Type	Combinations Total	Stock No.	Type	Combinations Total	Stock No.	Type	Combinations Total	Stock No.	Type	Combinations Total	Stock No.
A	1	36001	4C	4	36023	4A2B2D	8	36065	8AD	9	36057
C	1	36002	3CD	4	36024	4A4C	8	36042	6A3C	9	36045
2A	2	36004	2C2D	4	36025	4A2C2D	8	36055	3A3B2CD	9	36046
AC	2	36005	5A	5	36026	3AB3CD	8	36043	2A4B2CD	9	36056
AD	2	36006	4AD	5	36061	2A2B4C	8	36041	10A	10	36047
2B	2	36003	2A3C	5	36027	2A2B2C2D	8	36058	2A6B2C	10	36064
BC	2	36007	2A2CD	5	36028	A3B4C	8	36060	8B2C	10	36052
BD	2	36008	AB3C	5	36029	A3B3CD	8	36062	10AC	11	36053
2C	2	36009	ABC2D	5	36068	A3B2C2D	8	36044	12A	12	36048
2D	2	36010	2B3C	5	36030						
3A	3	36011	6A	6	36031						
2AC	3	36012	4A2C	6	36063						
2AD	3	36059	2A4C	6	36032						
A2B	3	36013	2A3CD	6	36033						
ABC	3	36014	AB3CD	6	36034						
3C	3	36015	6C	6	36035						
2CD	3	36016	4C2D	6	36036						
C2D	3	36017	3C3D	6	36037						
3D	3	36066	C5D	6	36067						
4A	4	36018	4A3C	7	36069						
2A2C	4	36019	2A5C	7	36038						
2A2D	4	36020	2A2C3D	7	36039						
AB2C	4	36021	AB5C	7	36054						
2B2C	4	36022	8A	8	36040						

The following spring combinations contain preliminary operating combinations that are also used in A Type Relay pile-ups.

Type	Combinations Total	Stock No.	Type	Combinations Total	Stock No.
Xa2C	3	36077	XaA3B2C	7	36082
Xa2AC	4	36074	XaB4C	7	36076
Xa2A2C	5	36083	Xa6AC	8	36087
Xa2ACD	5	36084	Xc4A3C	8	36085
Xc2A2BD	6	36073	Xc3A3BD	8	36079
XaAB3C	6	36071	Xa2A2B2CD	8	36081
XaABC2D	6	36078	Xa8AC	10	36075
Xa4A2C	7	36070	Xa5A3BC	10	36080
Xc2A2BCD	7	36086			

**A AND B TYPE RELAYS (Cont.)**

**Standard Coil Windings—"A" Type Relays**

**Quick-Acting Type**

**Coils with Single Windings**

Stock No. Coil	Approx. Ohms Resistance	Stock No. Coil	Approx. Ohms Resistance
36804	4.3	36814	350
36807	17	36815	560
36809	40	36816	850
36810	67	36817	1350
36811	100	36818	2120
36812	140	36819	3500
36813	220	36820	5500

**Coils with Two Concentric Windings**

Stock No. Coil	Approx. Ohms Resistance	Stock No. Coil	Approx. Ohms Resistance
36881	800-1220	36885	135-780
36882	214-2020	36886	332-1220
36883	514-1220	36887	514-2020
36884	1310-2020	36888	135-2020
		36897	61.5-1550

**Coils with Two Parallel Windings**

36951	20-20	36959	110-110
36953	34-34	36961	175-175
36955	50-50	36963	280-280
36957	70-70	36965	425-425

**Slow Acting Type**

**Copper Sleeve, 1/2" Diameter, over Entire Core  
Coils with Single Winding**

Stock No. Coil	Approx. Ohms Resistance	Stock No. Coil	Approx. Ohms Resistance
36861	11.8	36863	1330
36862	2400	36864	938

**Slow Release Type**

**A. Copper Collar 5/8" Long at Terminal End  
Coils with Single Winding**

Stock No. Coil	Approx. Ohms Resistance	Stock No. Coil	Approx. Ohms Resistance
36829	50.3	36834	420
36831	105	36835	638
36832	165	36836	1010
36833	262	36839	4120

**B. Copper Collar 1 1/4" Long at Terminal End  
Coils with Single Winding**

Stock No. Coil	Approx. Ohms Resistance	Stock No. Coil	Approx. Ohms Resistance
36858	660	36860	1710
36859	983		

**Coils with Two Concentric Windings**

Stock No. Coil	Approx. Ohms Resistance	Stock No. Coil	Approx. Ohms Resistance
36941	1075-1650	36943	7.7-985
36942	2.2-985	36944	640-985

**Slow Operate Type**

**Copper Collar 5/8" Long at Armature End  
Coils with Single Winding**

Stock No. Coil	Approx. Ohms Resistance	Stock No. Coil	Approx. Ohms Resistance
36841	2520	36843	4120
36842	1010	36844	262

**Coils with Two Concentric Windings**

36931	1560-2300	36932	595-909
-------	-----------	-------	---------

**How to Order "A" Type Relays**

The four basic spring combinations and the various types of coils with standard windings that are shown in the accompanying tables make it possible to provide "A" Type Relays that will meet most requirements. Consider, for example, a circuit that requires one "A" (make) and two "B" (break) contacts, making a total of three.

Referring to the table of basic spring combinations it will be seen that there are several 3-contact spring combinations but only No. 36013 has one "A" and two "B" contacts. This circuit, we assume, also requires a single wound coil of approximately

1300 Ohms. In the table of single wound coils No. 36817 (1350 Ohms) should be selected as this is the nearest to the exact resistance that is wanted.

Combining these two factors provides a complete "A" Type Relay with No. 36817 Coil and No. 36013 Spring Combination which is sufficient information for placing an order. In case the exact spring combination wanted is not shown, we recommend selecting one that provides extra contacts that will not be used as this is more economical than making a few relays that are not standard.

**Heavy Duty Relays**

Information about "A" Type Relays for heavy duty service can be furnished by our nearest office. These relays are equipped with single disc tungsten contacts and may be had with or without snap-action switches.

## A AND B TYPE RELAYS (Cont.)

### "B" Type Multi-Contact Relays

These are multi-contact units used in switching systems where reliable operation of a large number of contacts is essential. The "B" Type Relay will accommodate six stacks of spring combinations which are the same as the basic combinations used with "A" Type Relays. The use of twin palladium contacts assures long life and reliable operation.

- A—Make Contact                      C—Break-make contact
- B—Break Contact                     D—Make-before-break contact

The "B" Type Relay has a capacity of 54 "A" (make) contacts or the equivalent in other basic combinations as previously described. Due to special construction, the space occupied by the six-spring pile-ups is unusually small which makes this relay particularly desirable for group mounting.

Other component parts of the "B" Relay are similar to those of the "A" Type with the exception of the L Type armature and spring retainer which are necessarily of different design on account of the heavy spring load which is characteristic of multi-contact units.

The special frame-armature construction design of the "B" Type Relay provides a solid bearing for the armature which prevents "rocking" or bending under the large spring load that has to be carried. Lost motion at the contacts is counteracted by stiffening the armature with a support which is also used for adjusting armature travel. Inasmuch as a greater force is required to hold the armature in place than in the case of "A" Relays, a different type of spring retainer must be used.

(See illustration) This is a screw-and-coil-spring retainer especially designed to reduce the friction which is very small indeed compared with the heavy load that is carried.

Large leverage in the armature has also been retained in the "B" Type Relay and this provides the necessary long motion of the contact springs which permits them to operate individually like canti-lever beams. As in the case of the "A" Relay, a stepped phenolic single-piece spring pusher assures independent spring action so that the operation of one spring does not affect the operation of any other spring in the pile-up.

#### Types of "B" Relay Coils

Stock No.	Approx. Resistance	Stock No.	Approx. Resistance
36986	728 Ohms	36989	1070 Ohms
36987	175 Ohms	36990	2780 Ohms
36988	79 Ohms		

#### Standard Spring Combinations

Standard spring combinations consist of 24, 30, 36, 42, 48 and 54 "make" (A) contacts arranged as follows:

Total Make Contacts	Spring Combinations		Stock No.
	No. of Groups	Type	
24	3	8-A	36040
30	3	10-A	36047
36	3	12-A	36048
42	3	14-A	36049
48	3	16-A	36050
54	3	18-A	36051

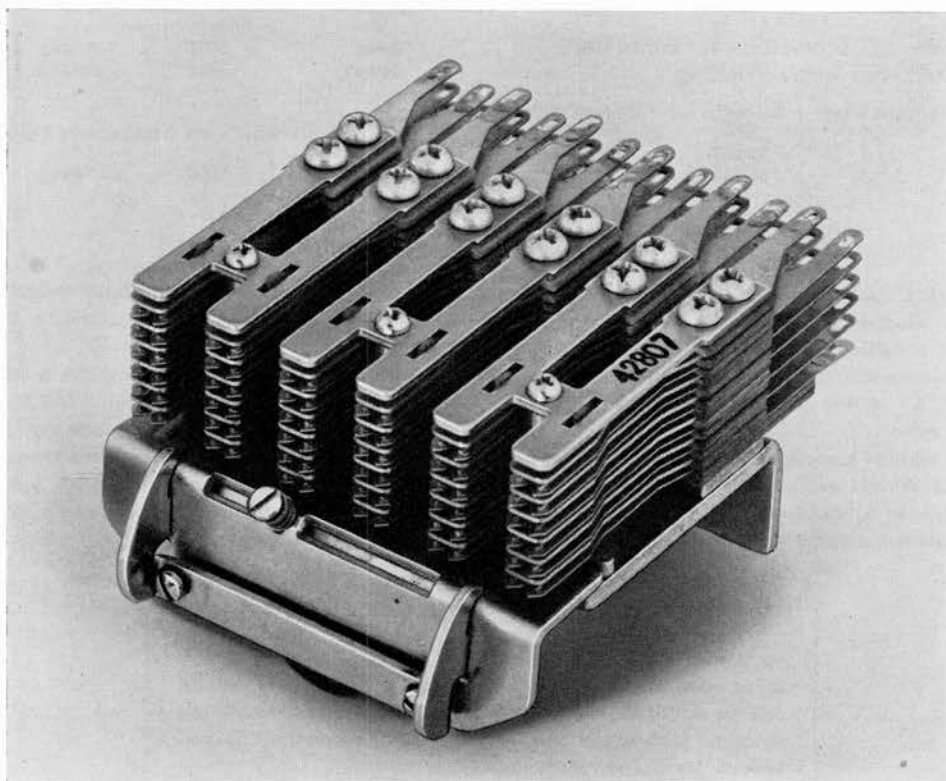

"B" Type Relay

**NOS. 500 AND 600 TYPE RELAYS**

Especially designed for Relay Dial Systems, these relays have also met with marked approval as general purpose relays. The design has taken advantage of the latest ideas in relay construction and operation, plus the old tried and reliable features.

**Outstanding Features**

**ONE-PIECE RELAY FRAME AND CORE ASSEMBLY** provides a complete magnetic circuit with the exception of the armature. The air gap end of the frame is ground flat, insuring precision of gap, and giving a knife-edge armature pivot. Frame is completely chromium plated after annealing which protects the armature knife-edge from wear.

**SPECIALLY DESIGNED SELF-CONTAINED COIL** withstands effects of heat and humidity and attendant electrolysis.

**SINGLE PIECE ANGLE ARMATURE** held in place by retainer, but free to rock on knife-edge pivot. Chromium plated parts assure an abrasion-proof, frictionless surface.

**UNIT ASSEMBLY OF SPRINGS** consists of two stacks of contact springs, each spring stack clamped together under pressure by two large Phillips head screws. The armature springs flex against heavy, rigidly positioned springs assuring permanent adjustment of the contacts.

**TWIN CONTACTS OF PRECIOUS METAL** insure reliable operation together with low contact resistance and long contact life.

The whole design embodies careful engineering to obtain

Simplicity	Easy Maintenance
Efficiency	Reliability

**Trouble-Free Operation**

Code numbers assigned to No. 500 and 600 Type Relays cover only the one-piece assembly of frame and core and standard coils of the types and resistances that are shown in a separate group with single, tandem, parallel and concentric windings.

In ordering complete relays the desired spring combination should also be indicated by affixing a letter for each combination desired according to the accompanying list. As an illustration of this method No. 510-A2B designates a 500 Type Relay with a single-wound 5000 ohm coil and a spring pile up consisting of one "make" and two "break" contacts.

The "500" Series are quick acting relays.

The "600" Series Relays are fitted with copper collars to produce either slow release or slow operate action.

**Basic Spring Combinations**

Heavy duty contacts may be furnished in "A," "B," or "C" contact arrangement. Indicated by placing "H" before the letter, thus HC. "H" contacts are of the "single" type, not "twin" type.

**Spring Designations**

- A—One make contact
- B—One break contact
- C—One break-make contact
- D—One break before make contact
- E—Two makes, sequence
- F—One break and two makes, sequence
- Q—One make before break, two separate contacts
- HA Heavy duty—One make contact
- HB Heavy duty—One break contact
- HC Heavy duty—One break-make contact

NOTE: Heavy duty are single (not twin) contacts.

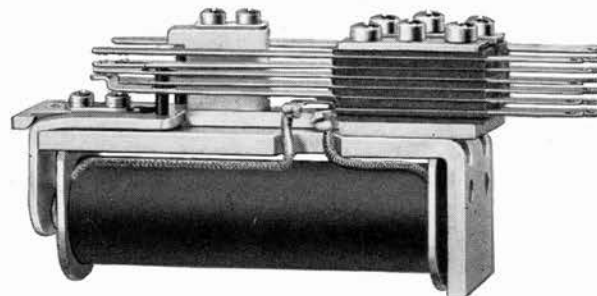

No. 500 Type Relay

**How to Order No. 500 or No. 600 Type Relays**

When ordering relays for additions or replacement to existing installations use the codes indicated in the specifications accompanying each switchboard or refer directly to the coding stamped on the armature of each relay. When orders are to be placed for relays not covered by the above data, the following provides an easy method for placing orders.

Following these paragraphs, diagrams and tables are shown. In the diagram covering basic spring combinations, each combination is indicated by letter. No. 500 and No. 600 Type relays can be equipped with only two spring stacks, but in building spring "pile-ups" as many as eleven individual contact springs may be placed in each stack. Standard arrangements of spring combinations will always be supplied to assure the customer of receiving the same "pile-ups" on subsequent orders.

In ordering relays specify first the code number which selects the resistance and style of coil.

**Example No. 1—506.** This indicates a relay with a single winding of 500 ohms.

**Example No. 2—622.** This indicates a slow release relay with two windings, 2000 ohms inductive and 500 ohms non-inductive.

In the tables covering coils, note that the relay code number as well as the resistance and style of coil are indicated. The styles cover "Single Winding," "Tandem Wound," "Parallel Wound," "Concentric Wound," "Slow Release," and "Slow Operate."

For the Second step in ordering relays select the spring combination to meet the circuit requirements.

**Example No. 1—2AC.** This signifies two "make" and one "break-make" contact.

**Example No. 2—AB.** This signifies one "make" contact and one "break" contact.

Then example No. 1 completed would read 506-2AC, and example No. 2 would read 622-AB.

In order to aid in the correct editing of orders, it is always desirable to provide a copy of the circuit in which the relays are to be used or to detail the current values on which the relay should operate and should not operate. Any other known requirements should be noted.

## NOS. 500 AND 600 TYPE RELAYS (Cont.)

### No. 500 Type—Quick Acting Relays Relay Frame and Windings—Less Springs

To make complete 500 Type Relays, letters should be affixed to the following code numbers to designate any of the standard spring combinations shown in the preceding table.

#### One Inductive Winding

Code No. Relay Less Springs	Approximate Ohms Resistance	Code No. Relay Less Springs
500	As Specified	509
501	5	510
502	50	511
504	100	512
505	200	513
506	500	514
507	1000	516
508	800	

#### Two Inductive Windings (Tandem)

Code No. Relay Less Springs	Approximate Ohms Resistance	Code No. Relay Less Springs
520	As Specified	525
523	200-200	526
524	500-500	

#### Two Inductive Windings (Parallel)

Code No. Relay Less Springs	Approximate Ohms Resistance	Code No. Relay Less Springs
530	As Specified	535
531	25-25	536
533	225-225	537
534	150-150	538

#### Two Inductive Windings (Concentric)

560	As Specified	567
561	500-1000	570
562	500-100	571
563	200-500	572
564	175-2100	573
565	100-10000	

#### Three Inductive Windings (Concentric)

Code No. Relay Less Springs	Approximate Ohms Resistance	Code No. Relay Less Springs
580	As Specified	582
581	1000-1000-1000	583

#### One Inductive Winding and One Non-Inductive Winding (Concentric)

Code No. Relay Less Springs	Approximate Ohms Resistance	Code No. Relay Less Springs
540	As Specified	551
543	500-100 N.I.	552
544	500-350 N.I.	553
546	200-60 N.I.	554
547	100-1000 N.I.	555
548	500-500 N.I.	556
549	1000-1000 N.I.	557
550	200-2000 N.I.	

#### TANDEM WOUND

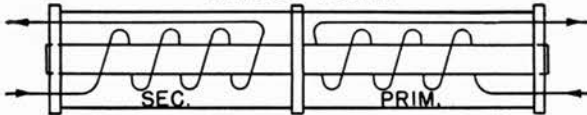

### No. 600 Type— Slow Release and Slow Operate Relays Relay Frame and Windings—Less Springs

To make complete 600 Type Relays, letters should be affixed to the following code numbers to designate any of the standard spring combinations shown in the preceding table.

#### Slow Release

##### One Inductive Winding

Code No. Relay Less Springs	Approximate Ohms Resistance	Code No. Relay Less Springs
600	As Specified	604
601	100	605
602	200	606
603	500	607

##### Two Inductive Windings

Code No. Relay Less Springs	Approximate Ohms Resistance	Code No. Relay Less Springs
610	As Specified	615
614	500-500	616

##### One Inductive Winding and One Non-Inductive Winding

Code No. Relay Less Springs	Approximate Ohms Resistance	Code No. Relay Less Springs
620	As Specified	625
621	500-500 N.I.	626
622	2000-500 N.I.	627
623	500-1000 N.I.	628
624	1000-800 N.I.	629

#### Slow Operate

##### One Inductive Winding

Code No. Relay Less Springs	Approximate Ohms Resistance	Code No. Relay Less Springs
630	As Specified	634
631	100	635
632	200	636
633	500	637

##### Two Inductive Windings

Code No. Relay Less Springs	Approximate Ohms Resistance	Code No. Relay Less Springs
640	As Specified	645
644	500-500	646

##### One Inductive Winding and One Non-Inductive Winding

650	As Specified	655
651	500-200 N.I.	656
652	2000-500 N.I.	657
653	500-1000 N.I.	658
654	1000-800 N.I.	659

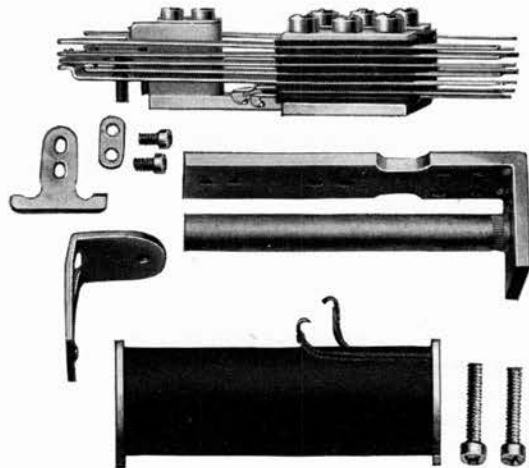

**NO. 720 TYPE RELAY**

The No. 720 Relay is used with Relay Dial Telephone Systems, but it also has applications in many fields where it is desirable to close a number of contacts simultaneously, for low voltage circuits.

**Characteristics**

**ONE PIECE FRAME AND ARMATURE** provides simplicity of design and effective operation. The air gap end of the frame is ground flat so that the armature operates on a knife-edge pivot. Chromium plating protects the armature knife-edge from wear.

**SPECIALLY DESIGNED COIL** withstands the effects of heat and humidity, preventing electrolysis.

**ASSEMBLY OF SPRINGS** in three individual sets allows uniform mounting of thirty-six (36) make contacts actuated by a single armature and using a single coil. Even spring distribution assures simultaneous spring operation.

**TWIN CONTACTS OF PRECIOUS METAL** insure reliable operation together with low contact resistance and long life.

The No. 720 Type Relay mounts in the same space as three No. 500 or No. 600 Type Relays. Well arranged and convenient switchboard layouts are thus made possible.

**NOTE:** No. 720 Type Relays are furnished with "make" contacts only. They are sold only as complete relay assemblies having proper factory adjustment.

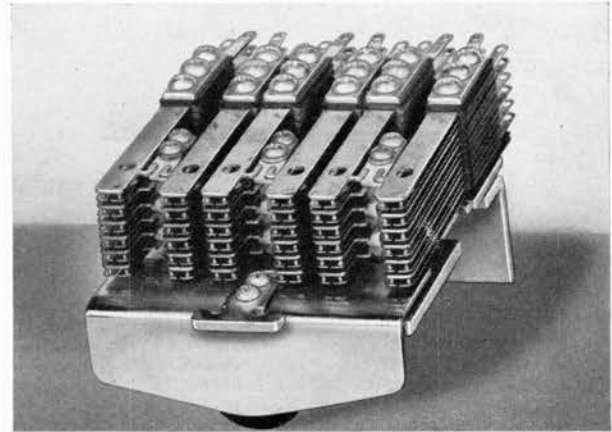

No. 720 Type Relay

Complete Relay		Coil Only	Approximate Ohms
Stock No.	Code	Stock No.	D.C. Resistance
40583	(723)	34125	500
48015	(724)	32744	800
40582	(725)	34124	2000

**RELAY CASINGS**

These are light-finished sheet steel casings for covering individual relays or groups of relays. They are used with various types of standard relay mountings and effectively protect the apparatus from dust and mechanical injury.

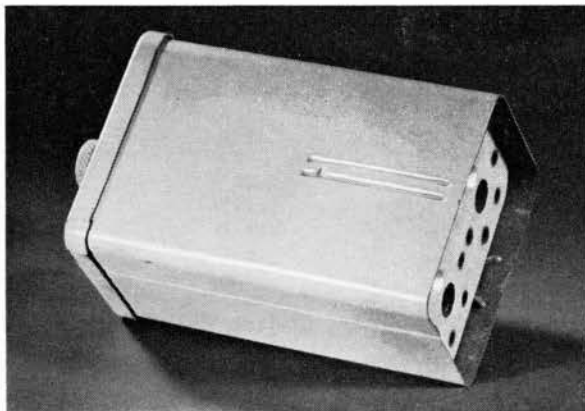

No. 25 Relay Casing



No. 21 Relay Casing

Stock No.	Code	No. & Type Relays Covered	Length Inches	Height Inches	Width Inches
801597	(16-L)	50 No. 190	9 9/16	3 3/8	3 1/2
801598	(17-L)	40 No. 190	7 3/4	3 3/8	3 1/2
801600	(18-L)	20 No. 190	4 1/8	3 3/8	3 1/2
	(19-L)	Replaced by No. 25 Casing			
801603	(20-L)	20 No. 200	12 5/64	3 3/4	3 41/64
801604	(21-L)	10 No. 200	12 5/64	3 3/4	1 49/64
801607	(23-L)	40 No. 190	23 13/32	3 3/4	1 59/64
801609	(24-L)	14 No. 200	16 49/64	3 3/4	1 49/64
*801610	(25)	2 No. 200	4	1 25/32	2 11/32
801611	(26)	6 No. 200	7 9/64	3 3/4	1 49/64

\*No. 25 Casing with 4" shell may be used for replacement on all Stromberg-Carlson Switchboards.

## RELAY MOUNTINGS

These relay mounting strips are light-finished plates of 3/16" strip steel designed for mounting relays shown in the following table, as well as those of our standard condensers which occupy the same space as the No. 200 Type Relays.



### Horizontal Type Mountings

Stock No.	Code	Number & Type Relays	Relay Casings	Mtg. Centers Inches	Length Inches	Width Inches
801652	(83-L)	100 No. 190	2 No. 16	25½	26	3¾
801653	(84-L)	120 No. 190	3 No. 17	25½	26	3¾
801654	(85-L)	40 No. 200	20 No. 25	25½	26	3¾
200473	(86-L)	60 No. 190	3 No. 18	20¾	21⅞	3¾
801657	(87-L)	16 No. 200	8 No. 25	20¾	21⅞	1⅞
801659	(88-L)	60 No. 190	3 No. 18	17	17½	3¾
801661	(89-L)	12 No. 200	6 No. 25	17	17½	1⅞
44361	(90-L)	10 No. 200	5 No. 25	13	13½	1⅞
801663	(91-L)	100 No. 190	2 No. 16	20¾	21⅞	3¾
45492	(92-L)	16 No. 200	8 No. 25	13	13½	3¾
801668	(96-L)	40 No. 190	1 No. 17	8¾	8⅞	3¾
801675	(101-L)	12 No. 200 (α)	1 No. 21, 25	18¾	18⅞	1⅞
801681	(104-L)	20 No. 200	10 No. 25	25½	26	1⅞
801683	(105-L)	40 No. 190	1 No. 23	25½	26	1⅞
801685	(106-L)	6 No. 200 (α)	3 No. 25	17	17½	1⅞
801688	(109-L)	10 No. 200 (b)	5 No. 25	17	17½	1⅞
801690	(110-L)	10 No. 200 (c)	5 No. 25	17	17½	1⅞
801692	(111-L)	14 No. 200	1 No. 24	18¾	18⅞	1⅞
801697	(116-L)	60 No. 190	3 No. 18	18¾	18⅞	3¾
801698	(117-L)	18 No. 200	9 No. 25	23¾	23⅞	1⅞
801699	(118-L)	28 No. 200	14 No. 25	23¾	23⅞	3¾
		20 No. 190	1 No. 18			
801700	(119-L)	6 No. 200 (d)	3 No. 25	17	17½	1⅞
801701	(120-L)	12 No. 200	1 No. 21, 25	17	17½	1⅞

(α) Mounts 2 No. 19 Condensers, (b) Mounts 2 No. 28 Condensers, (c) Mounts 2 No. 35 Condensers, (d) Mounts 2 No. 39 or 2 No. 43 Cond'rs.

The following relay mountings are also installed horizontally but molded insulations are used in the holes instead of individual bushings.

Stock No.	Code	Numbers Replaced	Number & Type Mounted Relays	Relay Casings	Mtg. Centers Inches	Length Inches	Width Inches
201729	(123)	87	16 No. 200	8 No. 25	20¾	21⅞	1⅞
201730	(124)	89	12 No. 200	6 No. 25	17	17½	1⅞
201731	(125)	104	20 No. 200	10 No. 25	25½	26	1⅞
201732	(126)	111	14 No. 200	1 No. 24-L	18¾	18⅞	1⅞
201733	(127)	119	8 No. 200	4 No. 25	17	17½	1⅞

### Vertical Type Mountings

These vertically installed mountings are used in relay cabinets and Stromberg-Carlson PBX Switchboards.

Stock No.	Code	Number & Type Relays Mounted	Relay Casings	Mtg. Centers Inches	Length Inches	Width Inches
801693	(112-L)	12 No. 200	6 No. 25	13	13½	2½
801694	(113-L)	18 No. 200	9 No. 25	18 13/16	19 5/16	2½
801695	(114-L)	12 No. 200, 2 No. 190	6 No. 25	18 13/16	19 5/16	2½
801696	(115-L)	22 No. 200	11 No. 25	22	22½	2½
801702	(121-L)	40 No. 200		39 1/16	39 9/16	2½
39829	(122-L)	23 No. 11 Repeat Coils		45 7/8	46 3/4	2½

### Angle Type Mountings

Stock No.	Code	Number & Type Relays Mounted	Relay Casings	Style Mounting	Length Inches	Width Inches
801665	(93-L)	1 No. 200	—	Floor	1½	1⅞
801666	(94-L)	1 No. 200	—	Sidewall	1 11/16	1
801667	(95-L)	2 No. 200	1 No. 25	Sidewall	2 19/32	1
801673	(100-L)	4 No. 200	2 No. 25	Roof	3¾	2½

**RINGERS**

**Small Telephone Type**

When furnished complete, these types are equipped with two-toned gongs which are assembled with the ringer movement to form a single compact unit. The gongs, however, are not furnished unless specified. The ringer unit is mounted on rubber so as to form a cushion which eliminates the clattering effect of a solid mounting. In this way a perfectly clear and pleasing tone is obtained which compels attention without being at all objectionable. Harmonic types are adjusted by a set screw in the movable weight that is attached to the clapper rod of the ringer.

The design of these ringers makes it easy to change from one frequency to another and when substitutions are made the only tool needed is a screwdriver.

Ringers of the small type include Nos. 59, 60, 61, 62 and 65 which are used with the following telephone sets:

Ringer		Common Battery	Common Battery
Code	Style	Handset Telephones	Desk Set Box
59	Harmonic	1210-1211-1212	None
61	Straight Line	1243-1250 1210-1211-1212	1260
62	Harmonic	1222-1223 1243-1250	1260
		Magneto	Magneto
65	Straight Line	Handset Telephones 1248-1258	Desk Set Box 1268

**Additional Charge for Gongs**

Gongs are not furnished with ringers unless specified. When required, the following parts should be specified for No. 61 and all other small type ringers such as Nos. 59, 62 and 65.

- 1—No. 28569 Gong
- 2—No. 28433 Screws
- 1—No. 28570 Gong
- 2—No. 526281 Washers

**Former Types**

Code No.	Replaced by Code No.	Description	Used on Telephones
55-56	61	S.L. Biased	1210-11-12
57	59	Harmonic	1210-11-12
60	*	Harmonic	1222-1223

\*No. 60 Ringer has been discontinued and replaced by No. 62 Type which will mount interchangeably by adding No. 201569 Bracket and No. 507152 Screw.

**Nos. 61 Biased Type**

The No. 61 Type Straight Line Biased Ringer is used universally: No. 61-A on all straight line common battery telephones and No. 61-S on Long Common Battery rural lines and on those magneto telephones that provide four party selective service.

Stock No.	Code	Resistance	Common Battery Telephone Used
801911	(61-A)	1800 Ohms	Nos. 1243, 1247, 1250
801912	(61-S)	4850 Ohms	*Same telos. on long rural lines.

\*Also Nos. 1248-WA and 1248-WS Magneto telephones

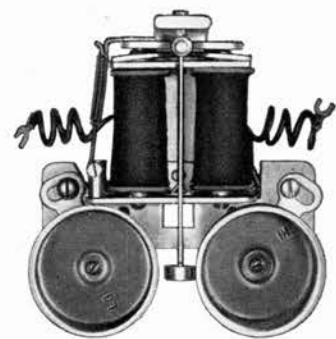

No. 61 Ringer

**No. 59 Harmonic Type**

Used with No. 1210 and 1211 Wall and No. 1212 Desk Type Handset Telephones which have been replaced by the No. 1250 Wall and No. 1243 Desk Models.

Stock No.	Code	Total Resistance	Description Less Gongs
801891	(59-E)	4700	16 2/3 Cycles Harmonic
801892	(59-F)	780	33 1/3 Cycles Harmonic
801893	(59-G)	780	50 Cycles Harmonic
801894	(59-H)	780	66 2/3 Cycles Harmonic
801898	(59-N)	4700	25 Cycles Harmonic
801895	(59-K)	780	30 Cycles Tuned
801896	(59-L)	780	42 Cycles Tuned
801897	(59-M)	780	54 Cycles Tuned
801899	(59-P)	780	66 Cycles Tuned
801900	(59-R)	4700	16 Cycles Tuned

**No. 60 Harmonic Type**

This ringer has been discontinued and replaced by the No. 62 Ringer with No. 201569 Bracket and No. 507152 Screw. When these additional parts are specified, the No. 62 Ringer will mount in place of the No. 60.

**No. 62 Harmonic Type**

The No. 62 Type Ringer is used with all present models of tuned frequency and harmonic common battery telephones.

Stock No.	Code	Total Resistance	Description Less Gongs
803475	(62-E)	4320	16 2/3 Cycles Harmonic
803476	(62-F)	780	33 1/3 Cycles Harmonic
803477	(62-G)	780	50 Cycles Harmonic
803479	(62-H)	780	66 2/3 Cycles Harmonic
803480	(62-N)	4320	25 Cycles Harmonic
803481	(62-K)	780	30 Cycles Tuned
803482	(62-L)	780	42 Cycles Tuned
803483	(62-M)	780	54 Cycles Tuned
803484	(62-P)	780	66 Cycles Tuned
803485	(62-R)	4320	16 Cycles Tuned
803474	(62-I)	4320	20 Cycles Two Freq. Syst.
803478	(62-J)	780	60 Cycles Two Freq. Syst.

Additional charge for gongs

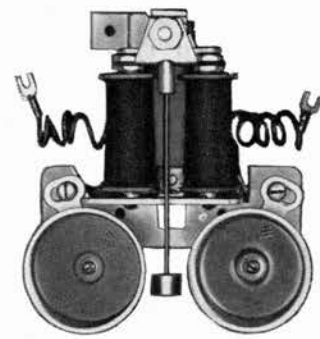

No. 62 Ringer

## RINGERS (Cont.)

### Small Telephone Type

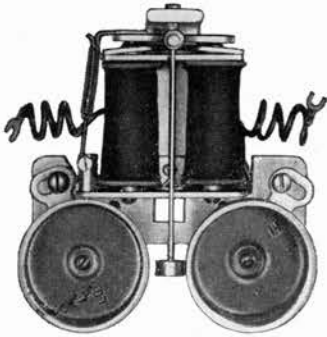

No. 65 Ringer With Biasing Spring

#### No. 65-C, 65-F Straight Line (Magneto) Type

This ringer is used with streamlined magneto telephones—No. 1248 Desk and No. 1258 Wall Types—and No. 1268 Desk Set Box.

Stock No.	Code	Total Resistance	Description Less Gongs
201754	(65-C)	3100	Straight Line
201755	(65-F)	4850	Straight Line

In the No. 65 Ringer, impedance, rather than resistances, have been matched with the large, old type ringers so that ringers of 3100 and 4850 Ohms resistance may be satisfactorily used on the same line with telephones having 1600 and 2500 Ohm ringers.

#### No. 65-B Biased (Magneto) Type

Used with No. 1248-WB Self-Contained Desk Type Handset Telephone in eight-party semi-selective magneto systems.

Stock No.	Code	Total Resistance	Description Less Gongs
202880	(65-B)	3100	Biased Type

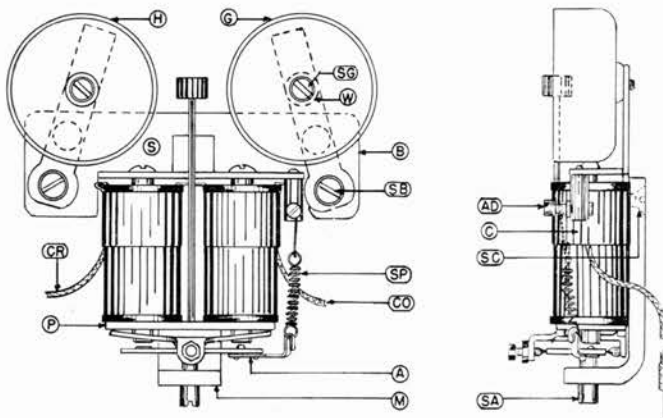

No. 61 Type Ringer

#### No. 61 Biased Type Straight Line Ringer

##### Miscellaneous Parts

Stock No.	Item	Name
34785	A	Armature Assembly
34668	AD	Adjusting Stud
34787	B	Bracket Assembly
27980	C	Coils (61-A Ringer)
34950		Coils (61-S Ringer)
44154	CO	Cord (Black)
44155	CR	Cord (Red)
28569	G	Gong
28570	H	Gong
27977	M	Magnet
23788	P	Plate
503653	S	Screws
33986	SA	Screw (Adjusting)
505383	SC	Screw
28433	SG	Screw (Gongs)
503520	SB	Screws (Gong adjusting)
16060	SP	Spring (Biasing)
526281	W	Washer
27975	D	Arms

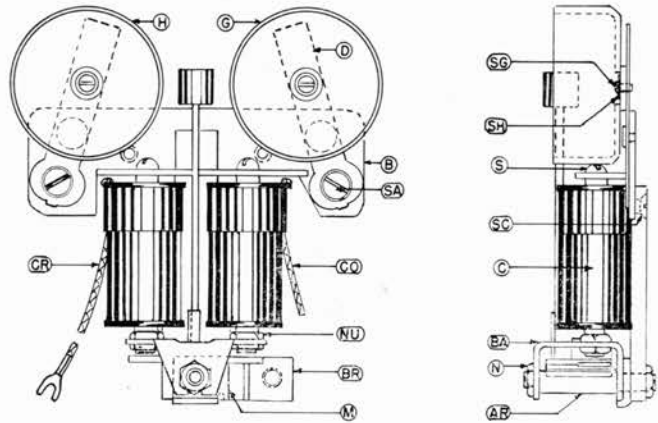

No. 62 Type Ringer

#### No. 62 Harmonic Ringer

##### Miscellaneous Parts

Stock No.	Item	Name
34304	AR	Arm.—Reed Assem.—16, 16 2/3, 20
34305		Arm.—Reed Assem.—25, 30, 33 1/3
34306		Arm.—Reed Assem.—42
34307		Arm.—Reed Assem.—50, 54, 60, 66, 66 2/3
27976	B	Bracket (Mounting)
23201	BA	Bracket (Armature)
35813	BR	Bracket
27981	C	Coil (No. 62-E, N, R)
27982		Coil (No. 62-F, G, H, K, L, M, P)
27975	D	Arms
28569	G	Gong
28570	H	Gong
44154	CO	Cord (T-1-D) Black
44156	CR	Cord (T-1-D) Red
28021	M	Magnet
23202	N	Nut
23114	NU	Nut
503653	S	Screw
505273	SC	Screw
526281	SH	Washer (Shake proof)
28433	SG	Screw (Gong)
503520	SA	Screw—Gong (Adj.)

RINGERS—PARTS (Cont.)

Small Telephone Type

No. 59 Harmonic Ringer

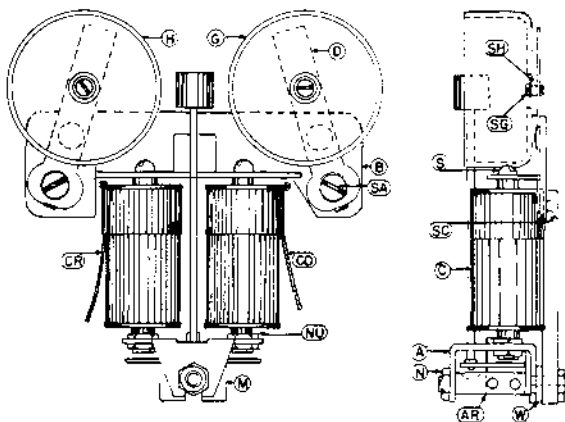

No. 59 Ringer

Miscellaneous Parts

Stock No.	Item	Name
23201	A	Bracket (Armature)
34304	AR	Arm.—Reed Assem.—16, 16 2/3, 20
34305		Arm.—Reed Assem.—25, 30, 33 1/3
34306		Arm.—Reed Assem.—42
34307		Arm.—Reed Assem.—50, 54, 60, 66, 66 2/3
27976	B	Bracket (Mounting)
27981	C	Coil (No. 59-E, N, R)
27982		Coil (No. 59-F, G, H, K, L, M, P)
44154	CO	Cord (T-1-D) Black
44156	CR	Cord (T-1-D) Red
27975	D	Arms
28569	G	Gong
28570	H	Gong
28021	M	Magnet
23202	N	Nut
23114	NU	Nut
503653	S	Screw
503520	SA	Screw (Gong adjusting)
505273	SC	Screw
28433	SG	Screw (Gongs)
526281	SH	Shakeproof Washer (Gongs)
28020	W	Washer
201643		Set screw (Armature weight)

No. 65-C, 65-F Straight Line Ringer

Miscellaneous Parts

Stock No.	Name
27976	Bracket Assembly (Gongs)
27975	Arms (2) Gong adjustment
503520	Screws (2) Arms
28569	Gong
28570	Gong
28433	Screws (2) Gongs
526281	Washers (2) Gong Screws
27977	Magnet
505383	Screw (magnet)
27973	Armature Assembly
33986	Adjusting Screw (Armature)
23788	Plate (Armature)
503653	Screws (2) Ringer Coils
201751	Coil (2) 65-C Ringer
34950	Coil (2) 65-F Ringer
44154	Cord T-1-D, 9" Black
44156	Cord T-1-D, 9" Red

No. 65-B Biased Ringer

Miscellaneous Parts

Stock No.	Description
34785	Armature Assembly
201751	Coils (2) 65-B Ringer
16060	Biasing Spring
34668	Adjusting Stud

NOTE: Other parts of the No. 65-B biased type are the same as used with Nos. 65-C and 65-F Ringers.

Ironclad Telephone Type Ringer

The No. 35 type ringer is especially designed for the No. 890 magneto and No. 950 common battery ironclad telephones. This ringer is assembled on a heavy brass plate which has no openings. The armature gong posts and two 4" gongs are mounted on the top of this plate and the two ringer coils underneath. A description of these ironclad telephones will be found in the magneto telephone section.

Stock No.	Code	Resist. Ohms	Description
801825	(35-A)	1000	Polarized Straight line
801826	(35-B)	1800	Polarized Straight line
801827	(35-E)	2500	Polarized Straight line
200577	(35-D)	80	Polarized Straight line

Additional Charge for Gongs

When gongs are to be furnished with rings one set of the following parts should be specified for each No. 35 Type.

Stock No.	Description	For one Ringer
8437	Gongs—4"	2
1345	Lock Nuts—	4

Miscellaneous Parts

Stock No.	Description
12271	Coil — 500 Ohms (35-A Ringer)
12272	Coil — 800 Ohms (35-B Ringer)
12273	Coil—1250 Ohms (35-E Ringer)
203457	Coil — 40 Ohms (35-D Ringer)
8426	Armature
8431	Bridge Piece
33986	Adjusting Screw

Inter-Communicating Type Ringers

This is our No. 37 direct current vibrating type ringer for the following wall type telephones used with old style Stromberg-Carlson Inter-Communicating Systems:

For Nos. 903, 904, 965, 968, 1122, 1163 Telephones.

Stock No.	Code	Resistance	Description
801828	(37-A)	20 Ohms	D.C. Vibrating—Less Gongs

Additional Charge for Gongs

When gongs are to be furnished with ringers one set of the following parts should be specified for each No. 37 Type Ringer:

Stock No.	Description	Required
9888	Gongs (2) 2"—Black brass	2
7571	Cap Nuts	2
1145	Lock Nuts	2
3738	Screws	2
1120	Washers (Screws)	2
614	Studs (Elevating)	2

Switchboard Ringers

No. 102 Type

A polarized biased ringer designed for use on small magneto switchboards such as the A-11740 wall type (see magneto switchboard section).

Each unit includes a 1600 Ohm Ringer with clear-toned gongs and an indicating drop shutter to show the switchboard operator from which line the call is coming.

Stock No.	Code	Total Resist.	Description
201853	(102-C)	1600	Polarized Biased
801815	(10-C)	1600	Ringer only—Less gongs

## RINGERS (Cont.)

### Small Telephone Type (Cont.)

#### Switchboard Ringers (Buzzer Type)



No. 50-LL Buzzer

Stock No.	Code	Resist. Ohms	Use
801822	(28-H)	100	No. 105 Swbd. Gen. Circuit
*801861	(50-LL)	500	Nos. 102, 106, 120 PBX N.A. Circuits

\*Will mount in the space of a casing on relay mounting plates.  
NOTE: Two No. 7408 Coils (50 Ohms) are used in each No. 28-H Ringer Assembly.

#### Switchboards Bells and Buzzers Vibrating Type

Stock No.	Code	Resist. Ohms	Use
38346	(571)	Bell 20	No. 125 Swbd. N.A. Circuit
200502	—	Bell 20	No. 126 Swbd. N.A. Circuit
39483	(570)	Buzzer 20	No. 125 Swbd. C.A. Circuit
200911	—	Buzzer 20	No. 126 Swbd. C.A. Circuit

#### Loud Ringing Water-Proof Bells

For indoor or outdoor service—see Supply Section for No. 53 Type.

#### No. 66 Harmonic Type

The No. 66 Type is used as a traffic ringer for intercept service in dial systems.

#### STOCK AND CODE NUMBERS

Harmonic Frequencies			
Stock No.	Code	Total Resistance	Description Less Gongs
203128	(66-E)	4320	16 2/3 Cycles
203129	(66-F)	780	33 1/3 Cycles
203130	(66-G)	780	50 Cycles
203132	(66-H)	780	66 2/3 Cycles
203133	(66-N)	4320	25 Cycles
Tuned Frequencies			
203134	(66-K)	780	30 Cycles
203135	(66-L)	780	42 Cycles
203136	(66-M)	780	54 Cycles
203137	(66-P)	780	66 Cycles
203138	(66-R)	4320	16 Cycles
Two Frequency Systems			
203127	(66-I)	4320	20 Cycles
203131	(66-J)	780	60 Cycles

These ringers are not equipped with gongs.

#### Miscellaneous Parts

Stock No.	Description	Associated Ringer
203150	Armature & Reed Assem.	No. 66-E, I, R
203151	Armature & Reed Assem.	No. 66-F, N, K
203152	Armature & Reed Assem.	No. 66-L
203153	Armature & Reed Assem.	No. 66-G, H, J, M, P
27981	Coil (390 Ohms)	No. 66-F, G, H, J, K, L, M, P
27982	Coil (2160 Ohms)	No. 66-E, N, I, R

### Large Telephone Type

Large size telephone ringers include the No. 46 Straight Line, No. 64 Harmonic and No. 49 Biased types. The 2 1/2" black finished gongs are drilled off-center for proper adjustment which is made by turning them on their posts to the proper position. Gongs are not furnished with ringers unless specified. These ringers are used with both common battery and magneto sub-station sets and will mount interchangeably on either steel or wood cabinets.

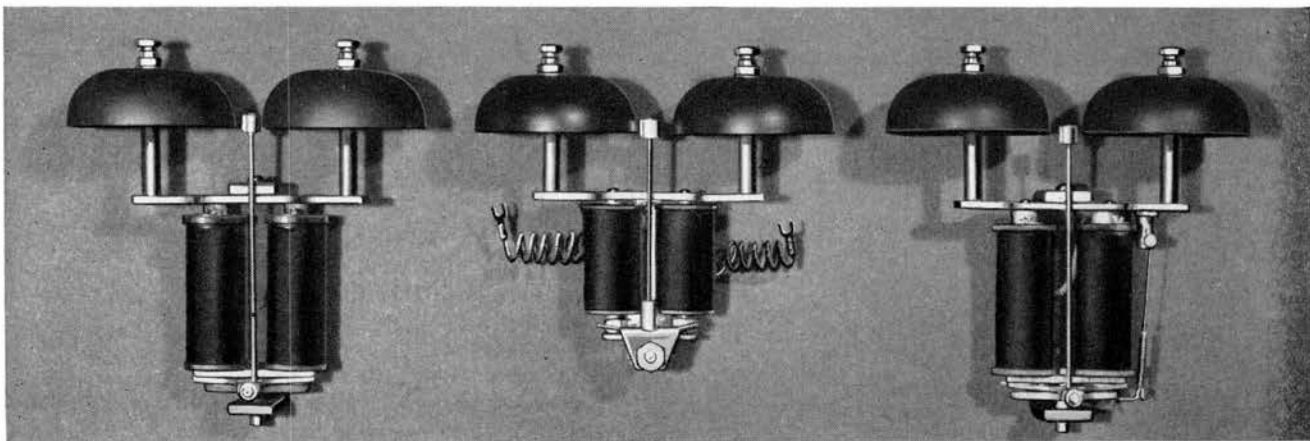

No. 46 Type

No. 64 Type

No. 49 Type

STROMBERG-CARLSON

RINGERS (Cont.)

Large Type Telephone Ringers

The No. 46 Ringer is a polarized type for straight line sets. The method of mounting the armature pivot on a brass yoke that bridges the pole pieces provides a single screw adjustment.

The No. 64 Type Harmonic Ringer (Replacing No. 47) is equipped with a reed armature which may be tuned to all frequencies in general use. The armatures and ringer coils are interchangeable so that when these coils are of the same resistance conversions can be easily made from one frequency to another. Adjustment is made by turning the set screw in the movable weight that is attached to the clapper rod of the ringer. The No. 49 Ringer is a biased type with adjustable tension spring. It is used on straight line biased sets to avoid tapping when dialing. For 4-party pulsating systems always specify the No. 52 type. Adjustment is the same as in the No. 46 Type Ringer.

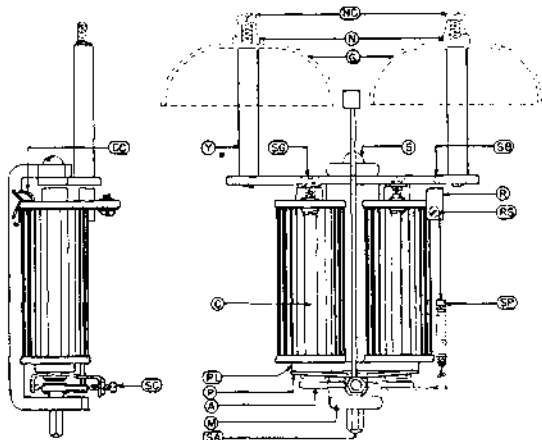

No. 49 Type

No. 46 Straight Line and No. 49 Biased Types

The following list covers parts for both the No. 49 and No. 46 Straight Line Ringers which are alike with the exception of a biasing spring and associated parts that are used with the No. 49.

Stock No.	Item	Name	Ringer Used On
2423	A	Armature	46
5025		Armature	49
12239	C	Coil (2)	46-A, 49-A
12240		Coil (2)	46-C, 49-C
12241		Coil (2)	46-F, 49-F
20266	CC	Conductor	46, 49
12047	G	Gongs (2)	46, 49
7485	M	Magnet	46, 49
525053	N	Nut (2)	46, 49
7571	NC	Cap Nut (2)	46, 49
4717	P	Plate Assembly	46, 49
579	PL	Plate	46, 49
34808	R	Adjusting Screw	49
34668	RS	Adjusting Stud	49
505355	S	Screw	46, 49
33986	SA	Adjusting Screw	46, 49
515285	SB	Screw	49
2580	SC	Screw (pivot)	46, 49
503783	SG	Screw	49
16060	SP	Spring (biasing)	49
8594	Y	Yoke Assembly	46
16061		Yoke Assembly	49

STOCK AND CODE NUMBERS

Stock No.	Code	Total Resistance	Description Less Gongs
<b>Polarized Systems</b>			
801830	(46-A)	1068	Straight line
801832	(46-C)	1600	Straight line
801835	(46-F)	2760	Straight line
801856	(49-A)	1068	Biased
801857	(49-C)	1600	Biased
801858	(49-F)	2760	Biased
<b>Harmonic Frequencies</b>			
47417	(64-E)	4320	16 2/3 Cycles
47416	(64-F)	780	33 1/3 Cycles
47415	(64-G)	780	50 Cycles
47412	(64-N)	4320	25 Cycles
47413	(64-H)	780	66 2/3 Cycles
<b>Tuned Frequencies</b>			
47423	(64-K)	780	30 Cycles
47422	(64-L)	780	42 Cycles
47421	(64-M)	780	54 Cycles
47420	(64-P)	780	66 Cycles
47419	(64-R)	4320	16 Cycles
<b>Two Frequency Systems</b>			
47418	(64-I)	4320	20 Cycles
47414	(64-J)	780	60 Cycles

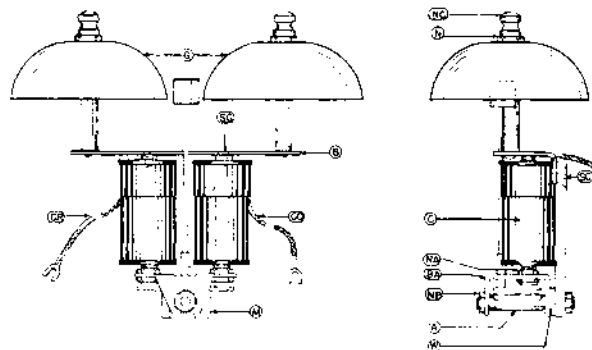

No. 64 Type

No. 64 Harmonic Ringer

Miscellaneous Parts

Stock No.	Item	Name
34304	A	Arm.—Reed Assem.—16, 16 2/3, 20
34305		Arm.—Reed Assem.—25, 30, 33 1/3
34306		Arm.—Reed Assem.—42
34307		Arm.—Reed Assem.—50, 54, 60, 66, 66 2/3
47424	B	Bracket Assembly (Mounting)
23201	BA	Bracket Assembly (Armature)
27981	C	Coil (No. 64-F, G, K, L, M, P)
27982		Coil (No. 64-E, 64-N, 64-R)
44156	CO	Cord (T-1-D) Red
44154	CR	Cord (T-1-D) Black
12047	G	Gongs(2)
28021	M	Magnet
23114	NA	Nut (4)
23202	NB	Nut(2)
7571	NC	Cap Nut (2)
503783	SG	Screw (2)
505273	SC	Screw
201643		Set Screw—Armature weight

## RINGERS (Cont.)

### Large Type Telephone Ringers

The No. 52 is a biased type polarized ringer designed for 4-party systems that use pulsating current.

Stock No.	Code	Description	Resistance
801864	(52-F)	Ringer (Biased)	2500 Ohms

### Additional Charge for Gongs

When gongs are to be furnished with ringers one set of the following parts should be specified for each No. 46, 47, 49, 52 or 64 Type.

Stock No.	Description	Quantity
12047	Gongs (Black Steel) 2½" Dia.	2
7571	Nuts (Cap)	2
1145	Nuts (Lock)	2
4241	Screw (Mtg.)	2
1120	Washer (Screw)	2
5312	Studs (Elevating) for Wood Mtg.	
or		
10716	Studs (Elevating) for Steel Mtg.	2

### No. 47 Type Harmonic Ringer

This ringer—formerly used with 4 and 5-party systems—has been replaced by the No. 64 type which mounts on the same drillings and is interchangeable in all other respects.

### Buzzer Type (Telephone)

Used with Stromberg-Carlson magneto test sets and telephones.

### Polarized Type Buzzers

Stock No.	Code	Resistance	Description
801820	(28-A)	1000	Polarized (Used on No. 843 Test Set)
801821	(28-C)	1600	Polarized (Used on No. 844 Test Set)
7408	Coil	(500 Ohms)	Used on No. 28-A Ringer
7408	Coil	(800 Ohms)	Used on No. 28-C Ringer

No gongs nor taper required for No. 28 buzzer type ringers.

### Miniature Type Buzzers

Stock No.	Code	Resist.	Description
*801757	(1-D)	132	Encased buzzer (No. 1215, 1216, 1270, 1271, 1272 Tels.)
†45304	(2-A)	1000	Encased buzzer (No. 1233 and 1233-M Telephones)

\*Used in Convenience Systems with desk type handsets

†Used in hookswitch box with suspended type handsets

## RINGERS FOR FORMER TELEPHONES

### Ringers for No. 1191 Handset Telephones

(This is a self-contained telephone for manual service only in which the gong of the ringer is mounted in the base. Replaced by No. 1243 Type designed for universal service).

Stock No. Ringer	Description	Code of Telephone
23789	Straight Line	(B)
23792	Biased	(BZ)
23368	16 2/3 Cycles	(E)
23365	33 1/3 Cycles	(F)
23366	50 Cycles	(G)
23367	66 2/3 Cycles	(H)
23369	25 Cycles	(N)
23373	20 Cycles	(I)
23374	60 Cycles	(J)
23370	30 Cycles	(K)
23371	42 Cycles	(L)
23372	54 Cycles	(M)
23928	66 Cycles	(P)

Stock No.	Name	Resist. Ohms	Frequency Cycles
23890	Coil	1150	30, 33 1/3, 42, 50, 54, 60, 66, 66 2/3
23199	Coil	2600	16 2/3, 20, 25
23791	Coil	725	Straight Line & Biased
24604	Gong (Black Finish)		

### Ringers for No. 1192 Handset Telephones

(This is a self-contained telephone, for either manual or dial service, with sub-base in which the ringer is mounted. Replaced by No. 1243).

Stock No. Ringer	Description	Code of Telephone
24654	Straight line	(B)
24655	Biased	(BZ)
24656	16 2/3 Cycles	(E)
24660	33 1/3 Cycles	(F)
24662	50 Cycles	(G)
24666	66 2/3 Cycles	(H)
24658	25 Cycles	(N)
24657	20 Cycles	(I)
24664	60 Cycles	(J)
24659	30 Cycles	(K)
24661	42 Cycles	(L)
24663	54 Cycles	(M)
24665	66 Cycles	(P)

Stock No.	Name	Resist. Ohms	Frequency Cycles
23890	Coil	1150	30, 33 1/3, 42, 50, 54, 60, 66, 66 2/3
23199	Coil	2600	16 2/3, 20, 25
23791	Coil	725	Straight Line, Biased
9888	Gongs (2)		

### Testing Equipment

Testing equipment for central office use as described in Section B includes wire chief's and toll testing outfits, sets for cord and general circuit tests and handsets types for use with common battery manual and dial systems.

Lineman's test sets, testing meters for various purposes and transmission test sets are shown in the catalogue section covering Telephone Construction Materials and Supplies.

**TERMINAL EQUIPMENT**

**Terminal Blocks**

The No. 16-A Terminal Block is used with the No. 1243-W and similar handset telephones for connecting the line cord and station wires.

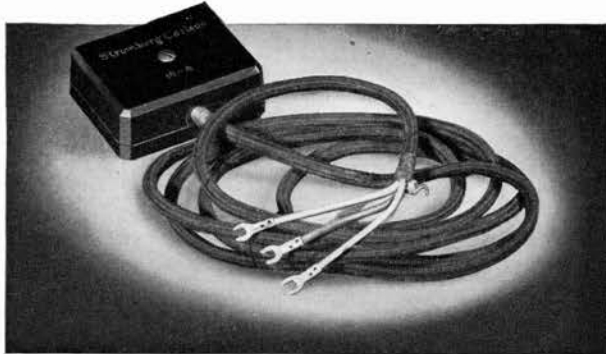

No. 16-A Terminal Block

**No. 201339 (16-A) Terminal Block—Less Cord**

This terminal block consists of a removable plastic cover and matching base containing an anchor post and four terminal plates each of which has two connecting screws.

The cover is attached to the base by a screw which threads into the center of the anchor post and notches are provided on opposite sides for the entrance of the line cord and station wires.

Dimensions: 2 1/2" x 2" x 27/32".

**Terminal Boxes**

The No. 90-A Terminal Box is used with desk type handset telephones in Stromberg-Carlson Convenience Systems described in Section D. This is a black plastic box—similar to the No. 1260 Desk Set Box—with removable base on which screw type terminals are mounted for making all necessary connections.

Stock No.	Code	Associated Handset Telephone
201983	(90-A)	No. 1270 (2-6 Systems) Nos. 1271, 1272 (2-10 & 3-9 Systems)

NOTE: Nos. 89-A and 89-B Terminal Boxes are used with old style No. 1195 (2-6) and Nos. 1215 and 1216 (2-10 and 3-9) Convenience System telephones.

**TERMINAL STRIPS**

**Terminal Strips—Wood Base Type**

These Terminal Strips are designed for mounting on the channel irons of distributing frames. They have hard wood maple bases drilled for jumper and cable wires and an elevating strip upon which the hard rubber terminal is mounted. Standard numbering can be applied to these strips.

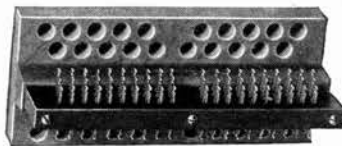

No. 45 Terminal Strip

Stock No.	Code	No. of Terminals	Dimensions
		Circuits per Circuit	Lgth. Thk. Ht.
802400	(44)	20 2	7 x 3 x 2 5/8"
802401	(45)	20 3	7 x 29/16 x 3"
802402	(46)	20 4	7 x 3 x 3 1/16"
802405	(49)	25 2	7 x 3 x 2 5/8"

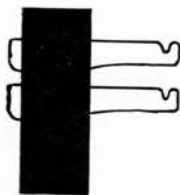

Terminal Arrangement of No. 70 and No. 71 Terminal Strips

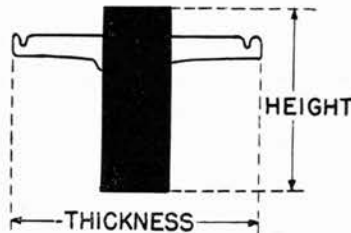

Diagram Showing Application of Dimensions

**Terminal Strips—Less Base**

Used for mounting on wood bases in accordance with distributing frame requirements. Terminals are made of sheet brass, with nickel finish and soldering ends tinned. Terminals are driven into hard rubber blocks and are staggered for ready wiring. The top face of the hard rubber blocks are smooth and allow the strip to be numbered for ready circuit identification.



No. 72 Terminal Strip



No. 79 Terminal Strip

Stock No.	Code	No. of Terminals	Dimensions
		Circuits per Circuit	Lgth. Thk. Ht.
802418	(68)	25 2	6 31/32 x 1 3/8 x 15/16"
802420	(70)*	20 1	10 7/32 x 1 1/8 x 15/16"
802421	(71)*	20 2	10 7/32 x 1 1/8 x 1 1/4"
802422	(72)	10 2	3 23/32 x 1 3/8 x 15/16"
802423	(73)	10 3	3 23/32 x 1 1/2 x 1 1/4"
802424	(74)	10 4	3 23/32 x 1 5/8 x 1 9/16"
802425	(75)	10 5	3 23/32 x 1 5/8 x 1 3/4"
802426	(76)	10 6	3 23/32 x 1 5/8 x 2 1/32"
802427	(77)	20 2	6 31/32 x 1 3/8 x 15/16"
802428	(78)	20 3	6 31/32 x 1 1/2 x 1 1/4"
802429	(79)	20 4	6 31/32 x 1 9/16 x 1 1/4"
802430	(80)	20 4	6 31/32 x 1 5/8 x 1 1/4"
802431	(81)	20 5	6 31/32 x 1 5/8 x 1 3/4"
802432	(82)	20 6	6 31/32 x 1 5/8 x 2 1/32"
802438	(88)†	23 6	7 13/16 x 1 5/8 x 2 1/32"

\*No. 70 and No. 71 Terminal Strips are equipped with terminals which have soldering clips on one side only. They are generally used in connection with protector strips on the arrester side of main distributing frames.

†Used in connection with multiple key turret apparatus for terminating six wire circuits, and making connections between turrets.

## TOOLS FOR SWITCHBOARDS, TELEPHONES, AND MISCELLANEOUS USE

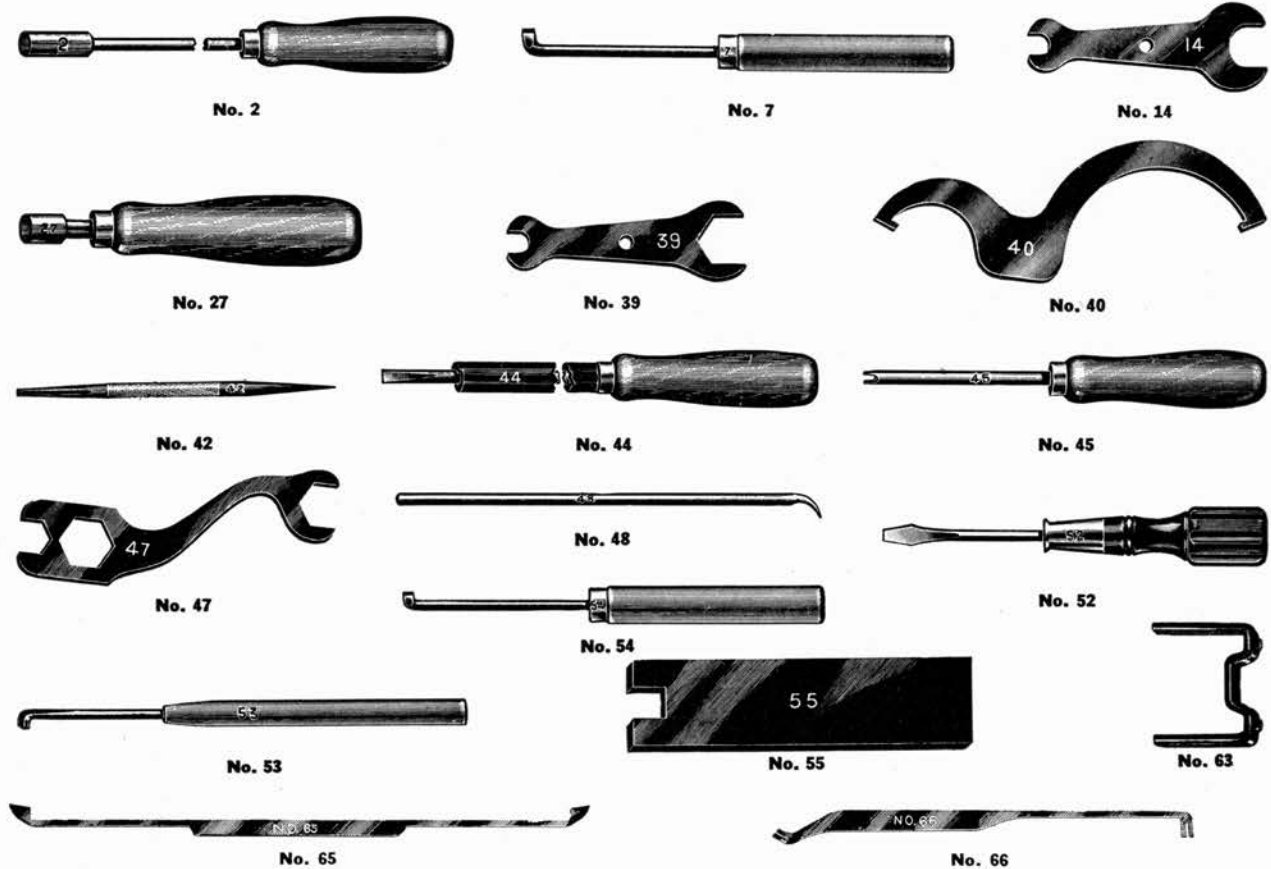

### Tools—Switchboard, Telephone, Miscellaneous

Stock No.	Code	Description	Stock No.	Code	Description
802456	(2)	Socket Wrench fits the 3/8" hexagonal mounting nut of all visual signals, impedance coils and relays (except the No. 190 Type Relay). Length, 6".	802474	(44)	Jack Fastener Wrench and Screw Driver used with the No. 17 Jack Fastener (Butterfly Type). Consists of a thick metal tubing, the end of which is notched to fit cut-out portion of butterfly jack fastener, and a screw driver which passes through the tubing. The screw driver tightens the screw while the tubing holds the fastener in place. Length, 19".
802457	(7)	Spring Adjuster used for adjusting springs up to .03" thick, on relays, keys, jacks, etc. Length, 7 3/32".	802475	(45)	Socket Screw Driver used for removing the Nos. 190, 200 and 300 Type Relays from the bridge plate. Length, 9".
2941	(14)	Flat Telephone Wrench fits the 3/16" and the 5/8" hexagonal nuts on straightline ringers of both common battery and magneto telephones. Length, 2 1/8".	13372	(47)	Flat Wrench used for adjusting No. 47 Type Harmonic Ringers. Length, 3 3/4".
8114	(27)	Socket Wrench used with 5/16" hexagonal nuts for miscellaneous uses. Length 6".	13428	(48)	Number Plate Extractor used for removing ring on the inside of Nos. 28, 29 and 30 Lamp Caps. Length, 3 7/8".
10438	(36)	Spring Adjuster for No. 200 Type Relays having three sets of springs. Length, 6 1/16". For smaller pile-ups use No. 268 Spring Adjuster.	802481	(52)	Screw Driver used for removing screw terminals on the No. 11 Drop. May also be used for any small screws. Length, 6 9/16".
11528	(39)	Flat Wrench used with 3/8" and 1/4" hexagonal nuts for adjusting the sleeve nuts on the No. 11 Drop. Length, 2 1/8".	802482	(53)	Spring Adjuster used for adjusting contact springs on the No. 360 Type Relays. Length, 3 7/8".
11635	(40)	Receiver Shell Wrench used for removing the shell from the Nos. 27 and 28 Receivers. Length, 4 3/4".	802483	(54)	Spring Adjuster used for adjusting No. 24 Gauge Springs on the No. 200 Type Relay. Length, 7 7/32".
12077	(42)	Screw Driver for removing both shell and terminal screws from standard plugs except No. 61. One end is pointed and fits in a hole drilled in top of screw, to facilitate starting of screw. Length, 3 3/8".	15092	(55)	Wrench used for holding the armature, while tightening yoke nut on the No. 47 Harmonic Ringer. Length, 4".
			802485	(56)	Small Screw Driver, for little screws such as those used on drop number plates. Length, 4 3/4".

TOOLS (Cont.)



Miscellaneous Tools, reading from the left:

Stock No.	No. 69	No. 70	No. 71	No. 72	No. 268	No. 553-A
Code	Description			Code	Description	
802487	(59)			201092	(70)	Lamp Cap extractor for all lamp caps. Length, 4 7/16".
15793	(60)			201566	(71)	Adjusting tool for changing regular No. 1243-W and 1250-W Telephones for two-step operation by adjusting the tab on the name plate lever. Length, 5 3/4".
16536	(61)			36372	(72)	Adjusting tool for light moving springs, armature back stop, and spring clamp plate on "A" Type Relays. Length, 3 9/32".
16646	(62)			36371	(73)	Tool for adjusting or removing "A" Type Relay pushers and spring stops. (2-3-4-5-6 steps) Length, 15/16".
23877	(63)			36377	(74)	Adjusting tool. Same as No. 73 only for 6-7-8-9 steps. Length 1 5/16".
29372	(64)			203401	(75)	Flat Wrench. For adjusting Nos. 61 and 65 Straight Line Ringers. One end (3/16") is used to adjust armature air gap and the other end (1/2") for loosening nuts to regulate the armature adjusting screw. Length, 3 1/8".
34048	(65)			802498	(268)	Spring Adjuster, 5 1/2" long suitable for adjusting relay springs up to .020" in thickness. Length, 5 1/2".
34049	(66)			38282	(319-B)	Cap Extractor, plier type with nipper mouth. Removes lamp caps with ferrules which extend outside or over mounting surface. Length, 4 3/4".
34746	(67)			38281	(553-A)	Lamp Extractor for removing 1/4" diameter switchboard lamps from lamp sockets. Made of slotted steel cylinder 17/64" diameter. Length, 3 3/8".
35194	(68)					
49937	(69)					

## TRANSMITTERS

All Stromberg-Carlson transmitters of recent manufacture are designed for universal service and are highly efficient on common battery, magneto and dial systems under varying current conditions. These transmitters eliminate the use of separate types for different kinds of telephones service. As a result of this, maintenance cost is greatly reduced because, without servicing work being impaired, stocks can be kept at a more economical level, in as much as one transmitter will do the work of two.

### No. 200486 Handset Type



No. 200486 Capsule Transmitter

The No. 200486 transmitter is an improved telephone product that is the result of knowledge gained from an exhaustive study of voice transmission in the radio field. Zoning is not necessary to conform with varying current conditions on long and short lines as these transmitters can be used with equally good results on all types of common battery and magneto lines.

The No. 200486 transmitter is a complete capsule unit designed to engage spring pressure contacts in an individual compartment in the handset handle. When the capsule is dropped in this compartment and the mouthpiece clamped firmly in place a solid contact is made at two different points. Additional features of the No. 200486 transmitter are:

**SOLID ONE-PIECE METAL FRAME**, accurately machined, permanently holds all parts in their correct relative positions.

**LIGHT-WEIGHT OUTER DIAPHRAGM** is constructed like a radio cone speaker with annular corrugations near the flat outer edge. This provides maximum flexibility while the center of the diaphragm vibrates as a rigid unit, with a piston-like motion.

**UNIFORMLY HIGH GRAVITY PRESSURE** is exerted on the electrodes regardless of the position of the transmitter cup.

**INNER AUXILIARY DIAPHRAGM** is extremely flexible and will not absorb moisture.

**A TENSION RING** prevents the carbon granules from packing.



Stock No. 200486 Name Transmitter



Use No. 20 Series Handsets on standard telephones.

### Former Handset Transmitters

Stock No.	Name	Use
24562	Transmitter	Nos. 15, 16, 17, 19 Handsets only, on old style telephones.

NOTE: Nos. 200486 and 24562 Handset Transmitters are not interchangeable.

### No. 20 Wall Set Type



### Used on Wall and Desk Stand Telephones

The No. 20 transmitter is an adaptation of the No. 200486 for use on wall and desk stand telephones. This universal transmitter, like the handset type, eliminates the necessity of zoning because it is highly efficient on long lines with low current supply and also on short heavy-current lines.

The front and mouthpiece of the No. 20 transmitter are combined in a single unit of molded black phenol compound which will withstand severe usage without breaking. A permanent finish also assures continued good appearance in actual service.

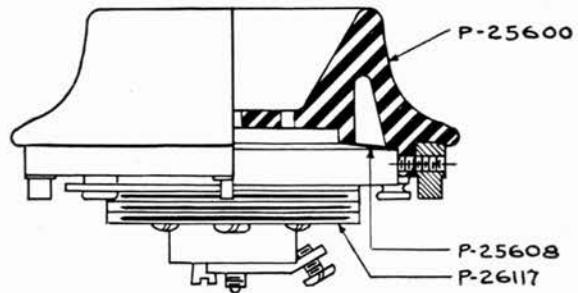

Drawing showing parts of No. 20 Transmitter

Stock No.	Code	Description
802522	(20)	Transmitter complete with back and mouthpiece
26791		No. 20—less back
26790		No. 20—less back and mouthpiece-front
25600		Mouthpiece-front only (No. 20)
12038		Back (Black)—No. 20
9077		Washer (Back)—No. 20
1266		Screw (2) Back to arm—No. 20
500155		Screw (4) Body to back—No. 20

No. 20 transmitter replaces Nos. 7-C, 7-CW, 19-C and 19-CW common battery and Nos. 7-L and 19-L magneto types.

Nos. 7, 19 and 20 Type Transmitters will all mount on the same back.

**TRANSMITTERS (Cont.)**

**No. 35434 Type for Ironclad Telephones**

This is a No. 20 transmitter—less the back—and with a special front having a threaded opening for a separate mouthpiece, instead of the moulded mouthpiece-front in one unit. No. 35434 transmitter is designed for mounting in the inner compartments of the No. 890 (magneto) and No. 950 (Common Battery) ironclad telephones.

Stock No.	Code	Description
35434		Transmitter (Less back and mouthpiece)
13774		Mouthpiece (Threaded)

**No. 21 Operator's Breastplate Type  
(Used on No. 4 Operator's Telephone Set)**



No. 21 Operator's Transmitter

A switchboard transmitter of the breast plate type. Universal in operation; can be used equally well on common battery or magneto switchboards. Performs efficiently under low or high current conditions. Has white enameled plate, nickel-plated front, and semi-vulcanized mouthpiece. Replaces former No. 18-CW and No. 18-L Transmitter on Nos. 3-C and 3-L Operator's Sets.

Stock No.	Code	Description
802523	(21)	Breastplate Transmitter
26790		Transmitter Unit
13483		Neckband and clasp
13484		Plate
5419		Mouthpiece
23056		Transmitter—less mouthpiece, plate, neckband.

**No. 22 Operator's Suspended Type  
(Used with Head Band Receiver)**

This transmitter is of the same construction as the No. 20 telephone type except that the back has bushed openings for suspension from an adjustable arm by means of two single conductor cords.

The No. 22 is an universal transmitter that replaces both the No. 8-CW (Common Battery) and No. 8-L (Magneto) operator's suspended type.

Stock No.	Code	Description
802525	(22)	Suspended transmitter complete with back (universal)

**Assembly Parts**

26791		Transmitter, less back and mouthpiece
26790		Transmitter, less back
25600		Mouthpiece-front (combined)
9819		Back

To complete the suspended type operator's set, the following apparatus is used with the No. 22 type transmitter.

Stock No.	Code	Description
801592	(29)	Receiver with headband, less cord
44269	(MO-2-I)	4' Receiver Cord
800632	(MO-1-A)	5' Transmitter Cord

**No. 12 Magneto Test Set Type**



No. 12-L Transmitter

A transmitter for magneto service only. Used on No. 844 Line-man's Test Set. Has perforated metal mouthpiece with nickel finish.

Stock No.	Code	Description
802516	(12-L)	Test Set Flush-mounting type

**Former Transmitters**

**A—Telephone Type—Nos. 7 and 19**

Common Battery	Magneto	Description	Use
7-C, 7-CW	7-L	Complete, Nickel	Desk Stands & Wall Sets.
19-C, 19-CW	19-L	Complete, Black	Desk Stands & Wall Sets.

NOTE: Nos. 7 and 19 replaced by No. 20 Universal Type.

**Assembly Parts**

Stock No.	Description	Complete Transmitter Common Battery	Magneto
7932	Front (Nickel) and trans. unit	7-C	—
15104	Front (Nickel) and trans. unit	7-CW	—
21454	Front (Black) and trans. unit	19-C	—
21455	Front (Black) and trans. unit	19-CW	—
7933	Front (Nickel) and trans. unit	—	7-L
21456	Front (Black) and trans. unit	—	19-L
9078	Back (Nickel)	7-C, CW	7-L
12038	Back (Black)	19-C, CW	19-L
9077	Washer (Back)	7, 19	19-L
1266	Screws (2) Back to arm	7, 19	19-L
2525	Screws (4) Trans. to back	7, 19	19-L
13774	Mouthpiece	7, 19	19-L
12911	Diaphragm	7, 19	19-L

**B—Operator's Breastplate Type—No. 18**

Common Battery	Magneto	Associated Headset Common Battery	Magneto
18-C	—	2-C	—
18-CW	—	3-C	—
—	18-L	—	2-L, 3-L

NOTE: Includes plate and mouthpiece.

**Assembly Parts**

Stock No.	Description	Associated Headset Common Battery	Magneto
13468	Transmitter less plate	2-C, 3-C	—
13788	Transmitter less plate	—	2-L, 3-L
13484	Breast Plate only	2-C, 3-C	2-L, 3-L
5419	Mouthpiece	2-C, 3-C	2-L, 3-L

**C—Operator's Suspended Type—No. 8**

Common Battery	Magneto	Description	Use
8-CW	8-L	Transmitter	Switchboards

NOTE: Includes back and mouthpiece.

**Assembly Parts**

Stock No.	Description	Associated Transmitter Common Battery	Magneto
15104	Front and trans. unit	8-CW	—
7933	Front and trans. unit	—	8-L
9819	Back	8-CW	8-L
9077	Washer	8-CW	8-L
3311	Screws (4) Trans. to back	8-CW	8-L
13774	Mouthpiece	8-CW	8-L
12911	Diaphragm	8-CW	8-L

## TRANSMITTER ADAPTERS AND ARMS

### Transmitter Adapters

Stromberg-Carlson desk stand and wall set type transmitters (Present No. 20 and former No. 7 Types) can be mounted on many telephone arms of other makes without the use of adapters. In such cases the current No. 20 Type or replaced No. 7 Type is used with standard No. 12038 Back and No. 9077 Washer.

For replacing other makes of transmitters having backs that are larger than the Stromberg-Carlson standard, an adapter ring can be furnished for mounting our No. 20 or No. 7 Type Transmitter. In this case No. 13073 Adapter should be specified.

Either by means of direct application or the use of adapters, Stromberg-Carlson transmitters will mount on many types of wall set and desk stand telephone arms of the following makes: American Electric, Automatic Electric, Century, Dean, Garford, Kellogg, Leich, Monarch, North, Western Electric.

### Transmitter Arms

#### No. 15 Transmitter Arm



No. 15 Transmitter Arm

Mounts on roof of switchboard. Generally used on PBX and central office switchboards. Adjusts to any desired position, swings horizontally, swings vertically and telescopes from a fully extended length of 23" to a fully contracted length of 14". Suspends the transmitter on flexible cords. Made of brass with black enamel finish.

Stock No.	Code	Description
802527	(15)	Transmitter Arm for Switchboards

### No. 19 Transmitter Arm

Used on No. 896 old style Magneto Wall Sets. Mounts on wood. Made of iron, finished in black enamel. Has vertical adjustment. Mounts current No. 20 Transmitter or replaced No. 7 Type.

Stock No.	Code	Description
802528	(19)	Adjustable Transmitter Arm



No. 19 Transmitter Arm

### No. 20 Transmitter Arms

No. 20 Type Transmitter Arms are used on wood or metal wall telephones. They are made of brass and iron, finished in black enamel. Only vertical adjustment can be made with this type of arm. They mount current No. 20 Transmitters or the replaced No. 7 Type.

Stock No.	Code	Description	Used with Wall Telephones
802529	(20-A)	Trans. Arm	No. 1126 (Wood Cabinet)
802530	(20-B)	Trans. Arm	No. 1155 and 1157 (Metal)



No. 20-B Transmitter Arm

## VISUAL SIGNALS

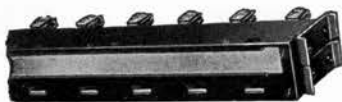

No. 18 Visual Signal  
on No. 121 Mounting

The No. 18 Type is a compact visual signal used as a "Busy Signal" on toll switchboards. Mounts similarly to jack strips. When operated, the signal appears white through a small window in the mounting. Each mounting is equipped with a designation strip.

The No. 18-A is used on systems operating from 11 cells of storage battery, and the No. 18-B is used on 20 cells. Requires No. 17 Jack Fastener.

### Visual Signal Mountings

Mtg. No.	Visuals per Strip	Face Length	Face Width	Mtg. Centers
120	20	10 $\frac{3}{8}$ "	1"	11 1/16"
121	10	10 $\frac{3}{8}$ "	1"	11 1/16"
122	10	7 19/32"	1"	8 $\frac{3}{8}$ "

### No. 18 Visuals Mounted

Stock No.	Code	Mounting	Resist. Ohms	Used with	
49871	(18-A)	Visual	120	1700	11 Cell Systems
49872	(18-A)	Visual	121	1700	11 Cell Systems
49873	(18-A)	Visual	122	1700	11 Cell Systems
49874	(18-B)	Visual	120	1700	20 Cell Systems
49875	(18-B)	Visual	121	1700	20 Cell Systems
49876	(18-B)	Visual	122	1700	20 Cell Systems

**STROMBERG-CARLSON**

# Cords

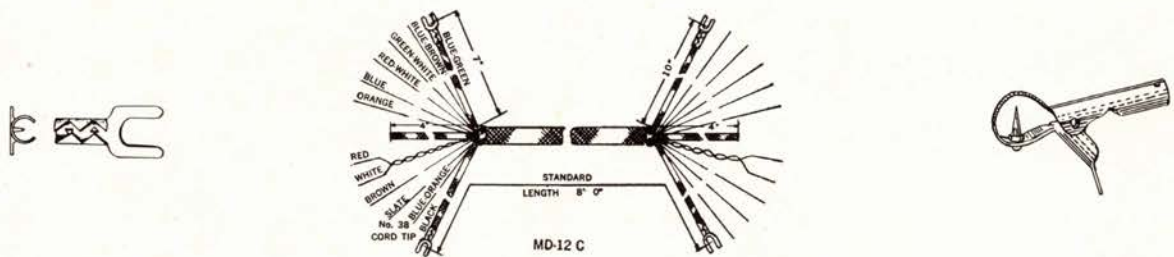

Cords, in themselves, are humble pieces of telephone equipment which can be responsible for reliable operation or endless trouble. It is just good business to select cords that will give satisfactory service year in and year out. There is a complete line of Duratex\* Cords for Stromberg-Carlson switchboard and telephone products as well as the products of other manufacturers. Duratex Cords have an enviable reputation for dependable and economical service under all kinds of operation conditions.

*\*Registered Trade Mark.*

CONTENTS  
SECTION G

**DURATEX CORDS**

---

Switchboard Cords .....	3g
-------------------------	----

---

Switchboard Cords with Plugs Attached .....	6g
---	----

---

Instrument Cords .....	7g
Desk Stand Cords .....	8g
Convenience System Cords .....	10g
Handset Cords .....	10g
Operator's Cords .....	12g
Receiver Cords .....	13g

---

Miscellaneous Cords .....	13g
---------------------------	-----

---

Terminal Cords .....	14g
----------------------	-----

---

Test Cords .....	14g
------------------	-----

---

Cordage .....	14g
---------------	-----

---

Cotton Sleaving .....	14g
-----------------------	-----

---

Stromberg-Carlson Replacements for other manufacturer's cords .....	15g
--	-----

---

Cord Adjusters, Fasteners, Hooks .....	16g
--	-----

---

Cord Weights .....	16g
--------------------	-----

---

Cord Tips .....	16g
-----------------	-----

---

**SPECIAL CORDS**

If your needs are not met in the following descriptions, send the Stromberg-Carlson Company at 100 Carlson Rd., Rochester, N. Y., a sample or a detailed description of your specific needs, and they will be glad to make up your cord requirements in the well-known Duratex Way.

### DURATEX SWITCHBOARD CORDS

The conductors of these cords are made in ribbon form from No. 37 AWG hard-drawn bronze alloy wire which is held to strict specifications. Before being used these ribbons are carefully tested for tensile strength, electrical resistance and maximum flexibility to make conductors of high conductivity and long-wearing qualities. The following step-by-step operations are examples of the care and thoroughness which have been important factors in building the reputation that Stromberg-Carlson has always had for dependable cord products.

1 — To make up a conductor strand two bronze alloy ribbons are spiraled in opposite directions around a cotton thread in a manner to cause the thread to take up all tension. The ribbons overlap to insure strength and conductivity. This type of strand construction produces conductors which are free from noise after long, hard use.

2 — Six of these strands are then wound around a strong center thread to form one conductor. Flexibility to a major degree is the result. Resistance in talking conductors is 0.9 ohms per 6 feet of cord length.

3 — Two servings of celanese are next applied and then an outer cotton braid with a colored tracer. This provides a moisture proof insulation which remains flexible and offers effective resistance to dampness and moisture caused by constant handling.

4 — The insulated conductors are then twisted together like the strands of a rope with proper fillers to form a round core.

5 — The core thus formed is kept in its original shape by the application of a cotton binder.

6 — At the end next to the plug a reinforcing braid is applied to offset the effects of severe bending when the cord is used.

7 — An outside braid of glazed long-fibre thread in standard colors of white, red, or green is then applied over the entire length of the cord, with the exception of the conductor terminating ends.

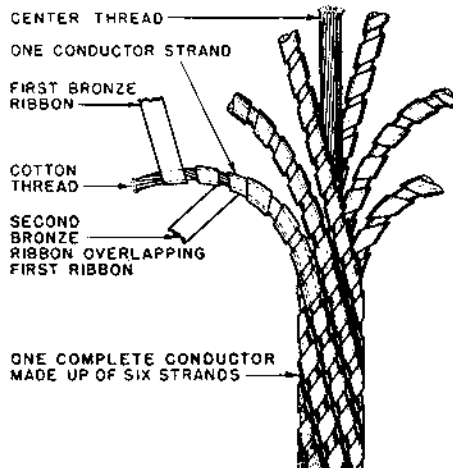

Single Conductor — Enlarged 10 Times

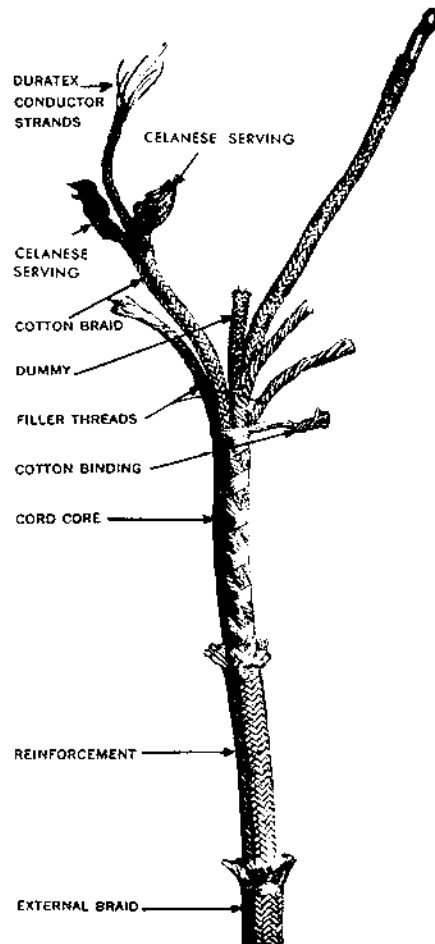

The two illustrations show more clearly than words that Stromberg-Carlson Duratex Cords are built to last. It will be appreciated, however, that any cord no matter how well made will fail if used improperly. These cords, with their ribbon wire construction, are much easier to re-butt than either steel or tinsel cords. Repairs if they become necessary can be made with a minimum of lost time.

## DURATEX SWITCHBOARD CORDS (Cont.)

White Duratex Switchboard Cords will be furnished unless otherwise specified, but red or green cords are also standard. Black cords are made only on special orders.

In the coding of these cords, the letter "S" denotes Switchboard, and the first numeral denotes the number of conductors. The rest of the code has to do with diameter and finish.

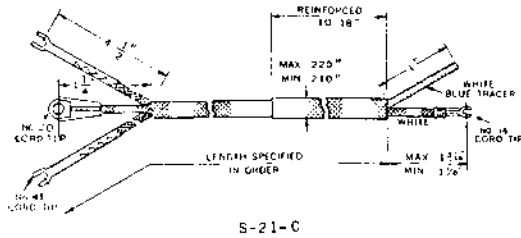

S-21-C  
(2 Conductor — 6, 7, 8 Ft.)

Stock No.	Code	Color	Length
44042	(S-21-C)	White	6 Ft.
44043	(S-21-C)	Red	6 Ft.
44044	(S-21-C)	Green	6 Ft.
44045	(S-21-C)	White	7 Ft.
44046	(S-21-C)	Red	7 Ft.
44047	(S-21-C)	Green	7 Ft.
44048	(S-21-C)	White	8 Ft.

Used with Nos. 33 and 39 Plugs.

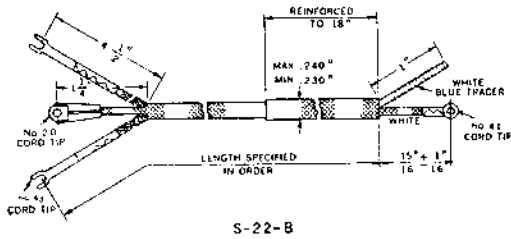

S-22-B  
(2 Conductor — 3, 6, 7 Ft.)

Stock No.	Code	Color	Length
	(S-22-B)	White	3 Ft.
	(S-22-B)	Red	3 Ft.
	(S-22-B)	Green	3 Ft.
44051	(S-22-B)	White	6 Ft.
44053	(S-22-B)	Red	6 Ft.
44054	(S-22-B)	Green	6 Ft.
47843	(S-22-B)	White	7 Ft.
44056	(S-22-B)	Red	7 Ft.
44057	(S-22-B)	Green	7 Ft.

Used with Nos. 36 and 57 Plugs.

Stromberg-Carlson Duratex Cords which replace equivalent cords of all types made by other manufacturers are shown in a list beginning on page 15G. These cords may be used without any modification, and will justify the change over a period of time.

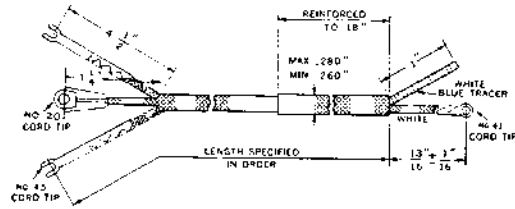

S-22-F

(2 Conductor — 3, 5, 6 Ft.)

Stock No.	Code	Color	Length
	(S-22-F)	White	3 Ft.
	(S-22-F)	Red	3 Ft.
	(S-22-F)	Green	3 Ft.
44061	(S-22-F)	White	5 Ft.
44062	(S-22-F)	Red	5 Ft.
44063	(S-22-F)	Green	5 Ft.
800604	(S-22-F)	White	6 Ft.
44065	(S-22-F)	Red	6 Ft.
803068	(S-22-F)	Green	6 Ft.

Equivalent to Kellogg 324-TO.

Used with 56 and 56-X Plugs, Kellogg No. 211 Plug and Garford two-Conductor Plugs.

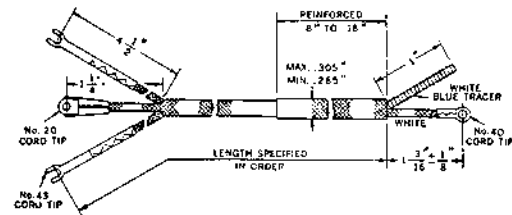

S-23-G

(2 Conductor — 2, 3, 5, 6 Ft.)

Stock No.	Code	Color	Length
44067	(S-23-G)	White	2 Ft.
44068	(S-23-G)	White	3 Ft.
44071	(S-23-G)	White	5 Ft.
44072	(S-23-G)	Red	5 Ft.
44073	(S-23-G)	Green	5 Ft.
44074	(S-23-G)	White	6 Ft.
44075	(S-23-G)	Red	6 Ft.
44076	(S-23-G)	Green	6 Ft.

Used with Nos. 10, 32, 42 and 43 Plugs.

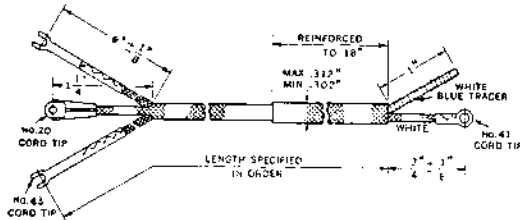

S-23-P

(2 Conductor 5, 6, 7 Ft.)

Stock No.	Code	Color	Length
44077	(S-23-P)	White	5 Ft.
44078	(S-23-P)	Red	5 Ft.
44079	(S-23-P)	Green	5 Ft.
800589	(S-23-P)	White	6 Ft.
47865	(S-23-P)	Red	6 Ft.
44081	(S-23-P)	Green	6 Ft.
44082	(S-23-P)	White	7 Ft.

Used with S-1 Plug, Kellogg Nos. 3, 42, 70, 109, 138 and Leich No. 3 Plug.

DURATEX SWITCHBOARD CORDS (Cont.)

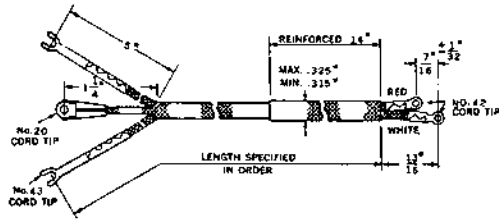

S-24-K

(2 Conductor — 5, 6, 7 Ft.)

Stock No.	Code	Color	Length
800587	(S-24-K)	White	5 Ft.
45378	(S-24-K)	White	6 Ft.
42516	(S-24-K)	Red	6 Ft.
42517	(S-24-K)	Green	6 Ft.
803079	(S-24-K)	White	7 Ft.

Used with Nos. 61 and 62 Plugs. Also W. E. Co.'s Nos. 27, 32, 47, 53 and 65 Plugs.

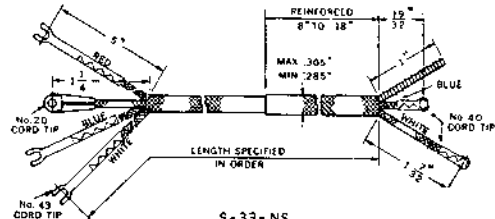

S-33-NS

(3 Conductor — 5, 6 Ft.)

Stock No.	Code	Color	Length
44131	(S-33-NS)	White	5 Ft.
44132	(S-33-NS)	Red	5 Ft.
44133	(S-33-NS)	Green	5 Ft.
800582	(S-33-NS)	White	6 Ft.
44135	(S-33-NS)	Red	6 Ft.
44136	(S-33-NS)	Green	6 Ft.

Used with No. 59 Plug. Also W. E. Co.'s No. 110 and Kellogg No. 191 Plug.

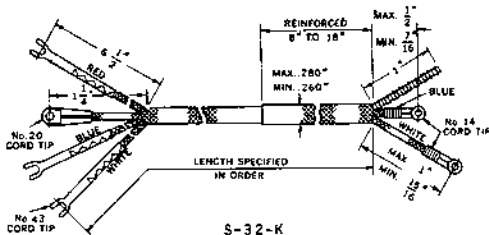

S-32-K

(3 Conductor — 3, 5, 6, 7 Ft.)

Stock No.	Code	Color	Length
42934	(S-32-K)	White	3 Ft.
800583	(S-32-K)	White	5 Ft.
42457	(S-32-K)	Red	5 Ft.
42456	(S-32-K)	Green	5 Ft.
801544	(S-32-K)	White	6 Ft.
801543	(S-32-K)	Red	6 Ft.
801582	(S-32-K)	Green	6 Ft.
801583	(S-32-K)	Black	6 Ft.
44101	(S-32-K)	White	7 Ft.
44109	(S-32-K)	Black	7 Ft.

Used with Nos. 53, 53-X, 54, 54-G, 54-N, 55, 55-N Plugs.

\*S-32-K Cords are replaced with S-32-P Cords when used in assembly with No. 65 Plugs.

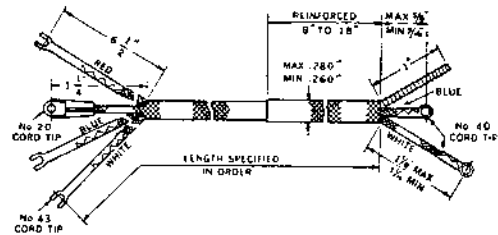

S-32-P

(3 Conductor — 3, 5, 6 Ft.)

Stock No.	Code	Color	Length
202225	(S-32-P)	White	3 Ft.
202226	(S-32-P)	White	5 Ft.
800588	(S-32-P)	White	6 Ft.
44125	(S-32-P)	Red	6 Ft.
44126	(S-32-P)	Green	6 Ft.
202227	(S-32-P)	Black	6 Ft.

Used with No. 63, 64 and 65 Plugs.

Switchboard Patching Cords for Two-Way Night Connections. Duratex Patching Cords for connecting a number of telephones to a trunk for two-way night service are made only as required. They consist of a single cord and plug for a trunk at one end, which is bridged to as many cords and plugs at the other end as there are lines to be connected for night service.

Inasmuch as patching cords are made only to required specifications, as complete information as possible should be furnished, including overall length, length of protruding conductors and type of plug.

A sketch showing these details or an actual sample will assure the correct type of cord being furnished.

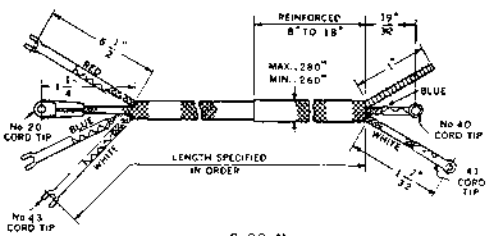

S-32-N

(3 Conductor — 6, 6½ Ft.)

Stock No.	Code	Color	Length
800586	(S-32-N)	White	6 Ft.
44114	(S-32-N)	Red	6 Ft.
44115	(S-32-N)	Green	6 Ft.
44117	(S-32-N)	White	6½ Ft.
44119	(S-32-N)	Red	6½ Ft.
44118	(S-32-N)	Green	6½ Ft.

Used with W. E. Cos. No. 109 Plug.

Switchboard Cords with Plugs attached are made up and carried in stock in the combinations which are most generally required. See page 6g for list of cord and plug assemblies with their associated stock numbers to be used in ordering.

## SWITCHBOARD CORDS WITH PLUGS ATTACHED



The following switchboard cords with plugs attached are carried in stock as standard items:

### Two Conductor Cords and Plugs

Stock No.	Cord	Plug
44050	S-22-B 5 Ft. White Cord assembled to	No. 57 Plug
44052	S-22-B 6 Ft. White Cord assembled to	No. 57 Plug
42623	S-22-F 5 Ft. White Cord assembled to	No. 56-X Plug
42462	S-23-G 5 Ft. White Cord assembled to	No. 42 Plug
42463	S-23-G 6 Ft. White Cord assembled to	No. 42 Plug
42513	S-24-K 3 Ft. White Cord assembled to	No. 61 Plug
38368	S-24-K 5 Ft. White Cord assembled to	No. 61 Plug
42515	S-24-K 6 Ft. White Cord assembled to	No. 61 Plug



### Three Conductor Cords and Plugs

Stock No.	Cord	Plug
44094	S-32-K 6 Ft. White Cord assembled to	No. 54 Plug
44102	S-32-K 7 Ft. White Cord assembled to	No. 54 Plug
44104	S-32-K 7 Ft. Red Cord assembled to	No. 54 Plug
44108	S-32-K 7 Ft. Green Cord assembled to	No. 54 Plug
44110	S-32-K 7 Ft. Black Cord assembled to	No. 49 Plug
44089	S-32-P 3 Ft. White Cord assembled to	No. 65-X Plug
42936	S-32-P 5 Ft. White Cord assembled to	No. 65-X Plug
42935	S-32-P 6 Ft. White Cord assembled to	No. 65-X Plug
44096	S-32-P 6 Ft. Red Cord assembled to	No. 65-X Plug
44098	S-32-P 6 Ft. Black Cord assembled to	No. 65-X Plug
44100	S-32-P 6 Ft. Green Cord assembled to	No. 65-X Plug
44124	S-32-P 6 Ft. White Cord assembled to	No. 54 Plug

Note — S-32-K Cords are replaced by S-32-P when used in assembly with No. 65 Plugs. The No. 53 Plug, which has been superseded by the No. 65 Plug, should not be used with the S-32-P Cord.

**DURATEX INSTRUMENT CORDS**

All instrument cords of Stromberg-Carlson manufacture are made with straight-lay conductors and an external braid of mercerized cotton.

Waterproof line and handset cords with black mercerized cotton braid are used on all current types of Stromberg-Carlson telephones. In these cords the conductors are individually insulated with extruded vinylite of contrasting colors to make a thoroughly waterproof cord that will give long and continuously reliable service, even in the dampest climates.

Other Duratex Cords, such as those for operator's telephone sets and miscellaneous use, are also made with straight-lay conductors. These cords have a distinguishing external braid of brown mercerized cotton and each conductor has a cotton insulation with colored tracer.

Duratex Instrument Cords described on the following pages are identified by various code numbers in which numerals and letters are used to denote the following features:

**Coding of Instrument Cords**

First letter — W or M shows type of braid.

**W** — Denotes waterproof cord with black braid

**M** — Denotes mercerized brown cotton braid

Second letter — D, C, O or R shows class of service.

**D** — Denotes desk type line cords for handset telephones and desk stands

**C** — Denotes cords for combination telephones and handset pieces

**O** — Denotes operator's cords

**R** — Denotes receiver cords

The numeral — Denotes number of conductors

Final letter — Denotes trim and type of terminals

**Coding for Special Uses**

**MISCELLANEOUS CORDS:** In classifying these cords the second letter is omitted and in this case the letter "M" indicates miscellaneous use rather than the type of braid. For example, the M-2-I, 16" cord which is used with the iron-clad telephones has a braid of glazed cotton rather than mercerized cotton.

**TERMINAL CORDS:** In this type of cord the second letter is also omitted and the letter "T" indicates use for various terminal purposes.

Line drawings and other data on Duratex Instrument Cords will be found on succeeding pages under the following headings:

- Desk stand (line) cords
- Handset (combination) cords
- Operator's cords
- Receiver cords
- Miscellaneous cords
- Terminal cords



Desk stand (line) cords

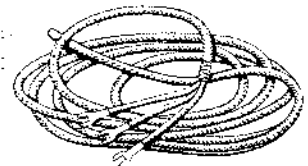

Handset (combination) cords



Operator's cords

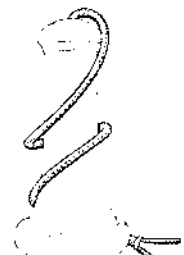

Receiver cords

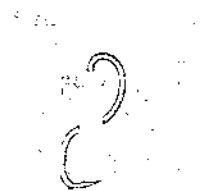

Miscellaneous cords

## DURATEX DESK STAND CORDS

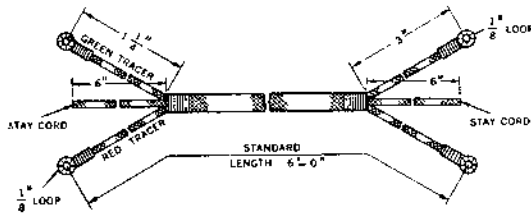

MD-2B

Stock No. Code Description  
**800544 (MD-2-B) 6' 2 Conductors**  
 Used with No. 20-A Receiver and No. 23 Plug

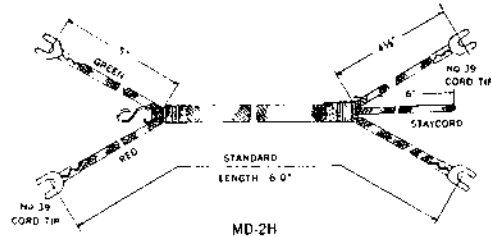

MD-2H

Stock No. Code Description  
**800598 (MD-2-H) 6' 2 Conductors**  
**800608 (WD-2-H) waterproof type, 6' 2 Conductors**  
 Used with No. 1222 Handset Telephone

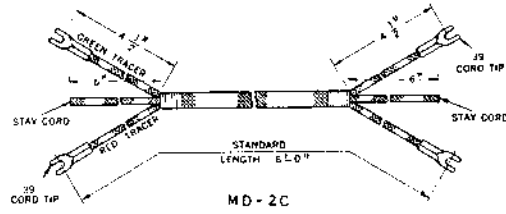

MD-2C

**800545 (MD-2-C) 6' 2 Conductors**  
 Used with No. 1179 Handset, also American Electric Desk Stands

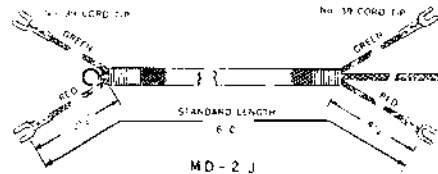

MD-2J

**803487 (MD-2-J) 6' 2 Conductors**  
**803489 (WD-2-J) waterproof type, 6' 2 Conductors**  
 Used on No. 1242 Telephone (Line Cord)

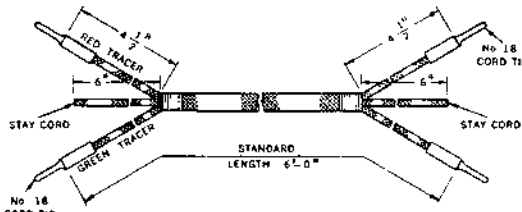

MD-2D

**800592 (MD-2-D) 6' 2 Conductors**  
 Used with Garford Type Desk Telephones

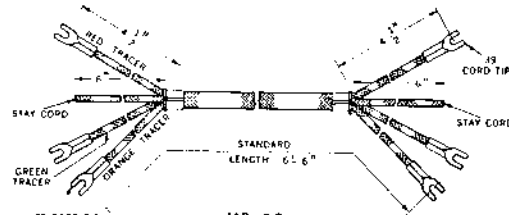

MD-3C

**800546 (MD-3-C) 6' 6" 3 Conductors**  
 Used with Nos. 992, 1168, 1170, 1171, 1173, 1174, 1176 Telephones, 1177 and 1178 Handsets, also W.E. Co's 51 Type Desk Stands, Kellogg Nos. F-115-A, F-118-B, F-135, F-138, 301 Telephones and American Electric Desk Stands.

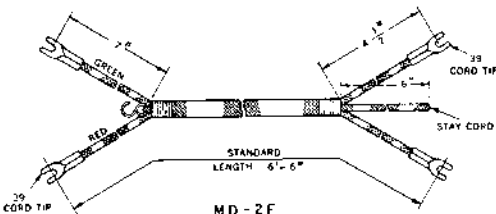

MD-2F

**44227 (MD-2-F) 5' 3" 2 Conductors**  
**800596 (MD-2-F) 6' 6" 2 Conductors**  
**800606 (WD-2-F) waterproof type, 6' 6" 2 Conductors**  
 Used with No. 1179 Handset, also American Electric Desk Stands

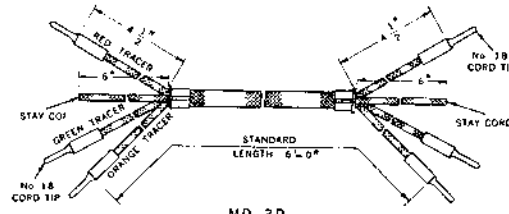

MD-3D

**44299 (MD-3-D) 6' 3 Conductors**  
 Used with Garford Type Desk Telephones

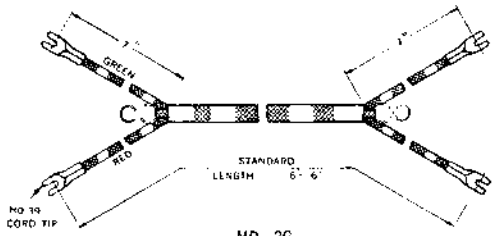

MD-2G

**800597 (MD-2-G) 6' 6" 2 Conductors**  
**200790 (WD-2-G) waterproof type, 6' 6" 2 Conductors**  
 Used with Nos. 1202 and SK 3400 Telephones

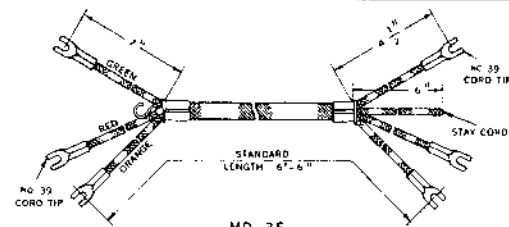

MD-3F

**800600 (MD-3-F) 6' 6" 3 Conductors**  
**800607 (WD-3-F) waterproof type, 6' 6" 3 Conductors**  
 Used with Nos. 1197, 1182, 1208 and 1212 Telephones

**STROMBERG-CARLSON**

DURATEX DESK STAND CORDS (Cont.)

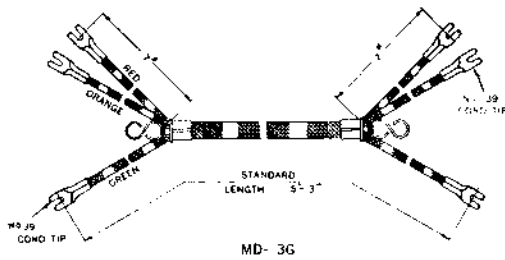

Stock No. Code Description  
 800601 (MD-3-G) 5' 3" 3 Conductors  
 Used with Nos. 1197, 1198 and 1207 Handset Telephones

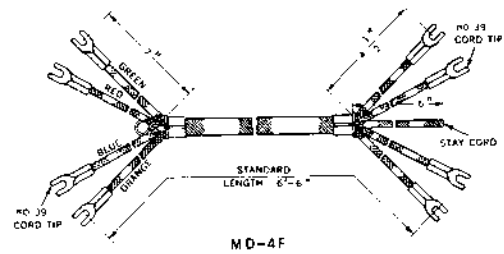

Stock No. Code Description  
 800602 (MD-4-F) 6' 6" 4 Conductors  
 Used with Nos. 1182-A and 1208-A Telephones

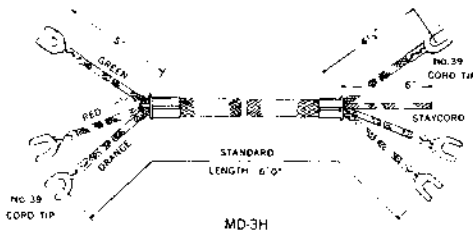

800599 (MD-3-H) 6' 3 Conductors  
 800609 (WD-3-H) waterproof type, 6' 3 Conductors  
 Used with No. 1223 Handset Telephones

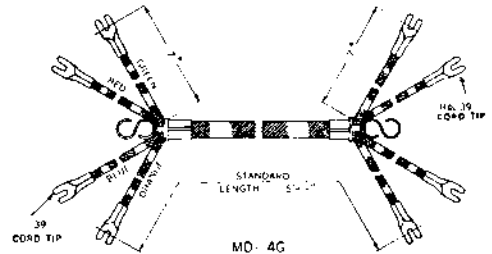

44344 (MD-4-G) 5' 3" Used with No. 1198-A Telephone  
 800603 (MD-4-G) 6' 6" Used with No. 1197-A Telephone  
 201374 (WD-4-G) 6' 6" waterproof type, used with No. 1244-W Telephone

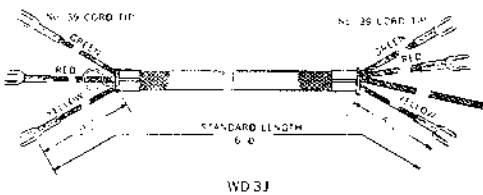

803488 (MD-3-J) 6' 3 Conductors  
 803490 (WD-3-J) waterproof type, 6' 3 Conductors  
 Used on No. 1243 and 1243-W Telephones

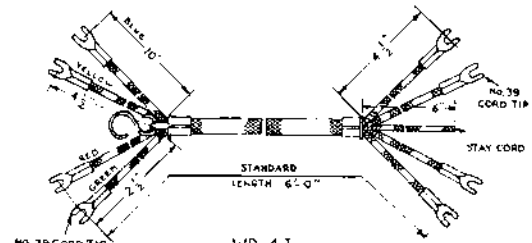

202236 (WD-4-J) 6' 4 Conductor, waterproof type  
 Used with No. 1248 Telephone

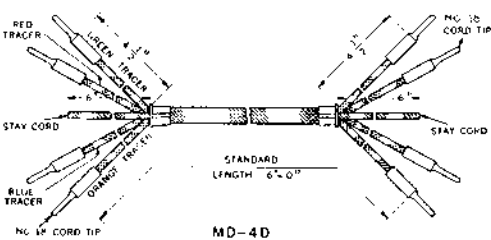

800591 (MD-4-D) 6' 4 Conductors  
 Used with Garford Type Desk Telephones

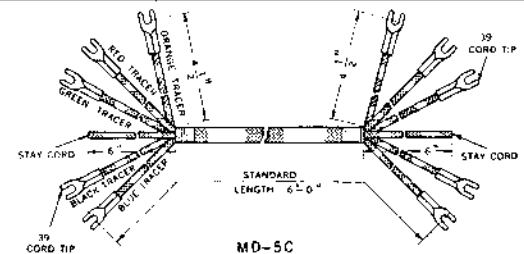

800594 (MD-5-C) 6' 5 Conductors  
 Used with Nos. 990, 1128-B, 1128-C, 1169, 1175, 1176, 1179-I, 1183 and 1189 Telephones

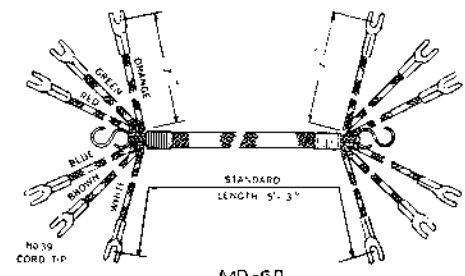

800610 (MD-6-D) 5' 3" 6 Conductors  
 Used with No. 1244-T and 1222-T Telephones

Stromberg-Carlson Duratex Desk Stand Cords, because of their straight-lay construction, resist the tendency to kink or knot. This not only prevents wear from abrasion, but also adds to the convenience of the user of the instrument, and increases his ultimate satisfaction.

## DURATEX DESK STAND CORDS (Cont.) FOR CONVENIENCE SYSTEMS

Color	"A" Dimension
BL-GR.	5½"
BL-BR.	5¼"
GR-WH.	5"
RED-WH.	6"
BLUE.	7"
RED.	1¾"
WHITE.	1¾"
ORANGE.	6¾"
BROWN.	6¼"
SLATE.	5¾"
BL-OR.	5½"
BLACK.	5¾"
BLK-RED.	4½"
GR-RED.	3¼"
OR-GR.	5½"
BL-WH.	4¾"
OR-WH.	4½"
BLK-WH.	4¾"

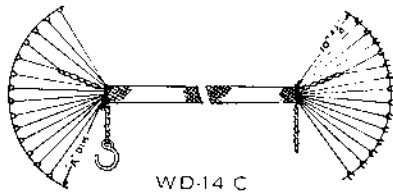

Stock No. 202325 Code (WD-14-C) Description 8' 14 Conductors

Used with new style No. 1270 Telephones in current No. 2-6 Convenience Systems.

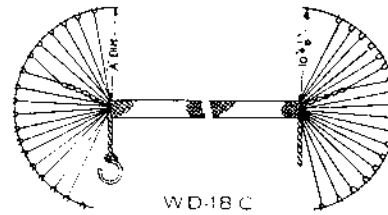

Stock No. 202326 Code (WD-18-C) Description 8' 18 Conductors

Used with new style No. 1271 and No. 1272 Telephones in current No. 2-10 and No. 3-9 Convenience Systems.

Color	"A" Dimension
BL-GR.	5"
BL-BR.	5½"
GR-WH.	5¼"
RED-WH.	6"
BLUE.	7"
ORANGE.	6¾"
RED.	1¾"
WHITE.	1¾"
BROWN.	6¼"
SLATE.	5¾"
BL-OR.	5½"
BLACK.	5¾"
GR-RED.	3¾"
BLK-RED.	5"

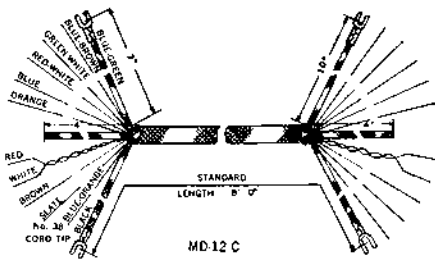

\* 23811 (MD-12-C) 8' 12 Conductors

Used with No. 1195 Telephones in older No. 2-6 Type Convenience Systems.

\*For cords used with streamlined telephones in the new No. 2-6, 2-10 and 3-9 Systems see WD-14-C and WD-18-C Types.

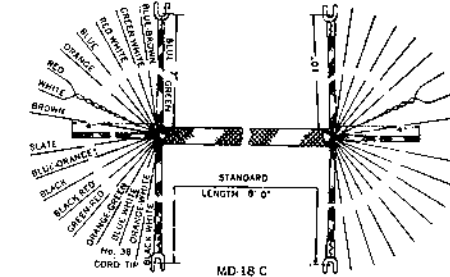

\* 28629 (MD-18-C) 8' 18 Conductors

Used with No. 1215 and No. 1216 Telephones in older No. 2-10 and No. 3-9 Convenience Systems.

## DURATEX HANDSET CORDS

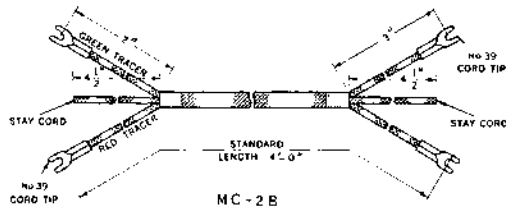

Stock No. 800611 Code (MC-2-B) Description 4' 2 Conductors

Used with Nos. 10-PC, 10-D, 10-S, 14, 1181-A, 1181-B, 1181-D, 1181-DJ, 1181-E Handsets.

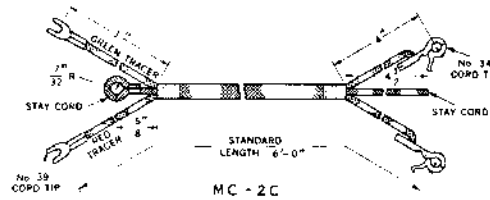

Stock No. 800612 Code (MC-2-C) Description 6' 2 Conductors

Used with Nos. 11-C, 11-D, 11-E, 19-C and 19-D Handsets

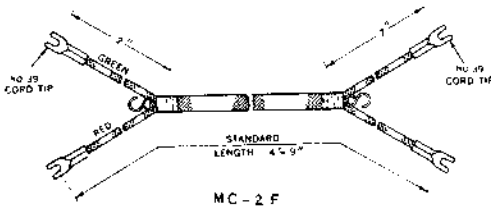

800613 (MC-2-F) 4' 9" 2 Conductors

Used with Nos. 17 and 22-A Handsets

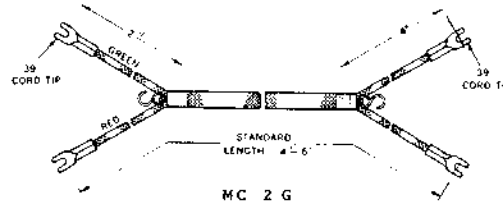

800614 (MC-2-G) 4' 6" 2 Conductors

Used with No. 22 Handset

STROMBERG-CARLSON

DURATEX HANDSET CORDS (Cont.)

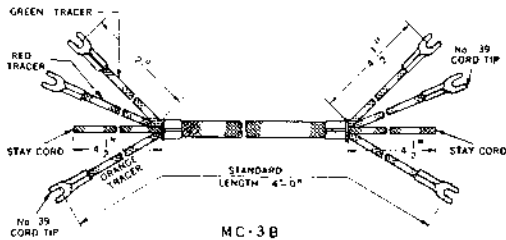

MC-3B  
**Stock No.**    **Code**    **Description**  
**800615**    **(MC-3-B)**    **4' 3 Conductors**  
 Used with Nos. 10, 12 and 19-L Handsets  
**44209**    **(MC-3-B)**    **6' 3 Conductors**  
 Used with No. 11-L, 19-L and 1181-C Handsets

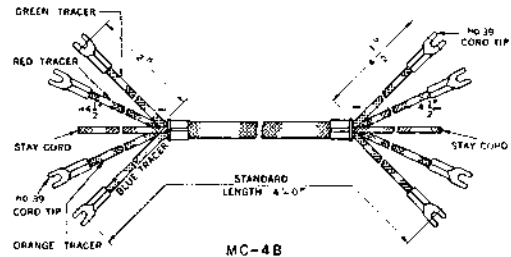

MC-4B  
**Stock No.**    **Code**    **Description**  
**800619**    **(MC-4-B)**    **4' 4 Conductors**  
 Used with Nos. 10 and 13 Handsets

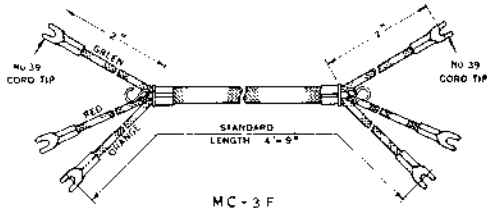

MC-3 F  
**800617**    **(MC-3-F)**    **4' 9" 3 Conductors**  
**800624**    **(WC-3-F)**    **waterproof type 4' 9"**  
 Used with Nos. 15 and 20-A Handsets, 1201-C, 1201-CA, 1191-B, 1195, 1197, 1197-A, 1202, 1210-A, 1211-M, 1212, 1215 and 1216 Telephones

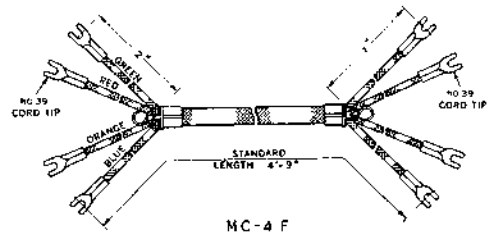

MC-4 F  
**800621**    **(MC-4-F)**    **4' 9" 4 Conductors**  
 Used with No. 16 and 21-A Handsets and No. 1192, 1193, 1198-A, 1207 Telephones  
**201497**    **(WC-4-F)**    **waterproof type 4' 9"**  
 Used with 21-W Handset and D-2843 Telephone

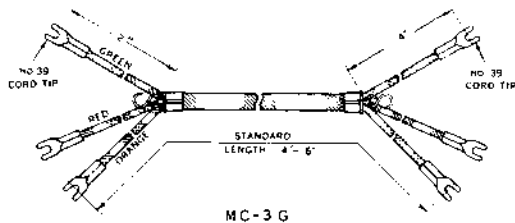

MC-3 G  
**800618**    **(MC-3-G)**    **4' 6" 3 Conductors**  
**800625**    **(WC-3-G)**    **waterproof type 4' 6"**  
 Used with No. 20 Handset and Nos. 1222, 1223, 1224-A Telephones

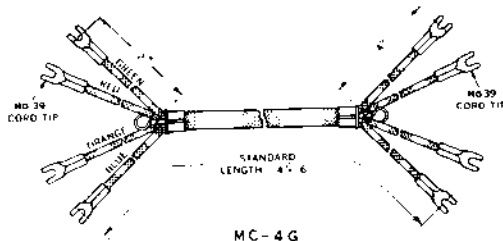

MC-4 G  
**800622**    **(MC-4-G)**    **4' 6" 4 Conductors**  
 Used with No. 21 Handset (D-2843 Telephone)

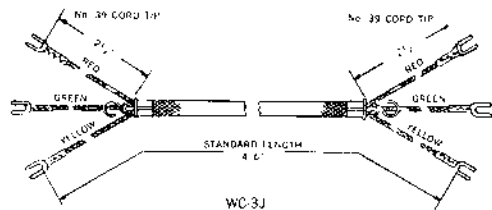

WC-3J  
**803551**    **(MC-3-J)**    **4' 6" 3 Conductors**  
 Used on No. 23 Handset which has been replaced by No. 23-W with waterproof cord  
**803552**    **(WC-3-J)**    **waterproof type 4' 6"**  
 Used on No. 23-W Handset and Nos. 1243-W, 1244-B and 1250-W Telephones

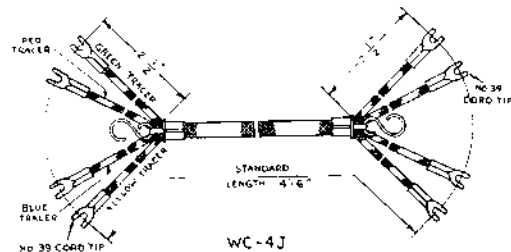

WC-4 J  
**202235**    **(WC-4-J)**    **4' 6" 4 Conductors, waterproof type**  
 Used on No. 24-W Handset and Nos. 1248-W and 1258-W Telephones.

Colored Cords

When Duratex Cords are required for colored handsets the number of conductors should be specified as well as the color of the telephone.

## DURATEX OPERATOR'S CORDS

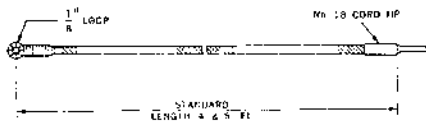

MO-1A

Stock No. Code Description  
**800632 (MO-1-A) 5' Single Conductor**  
 Used with operator's suspended type transmitters.

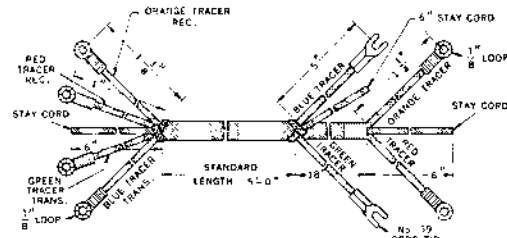

MO-4C

Stock No. Code Description  
**800640 (MO-4-C) 4' 4 Conductors**  
**800640 (MO-4-C) 5' 4 Conductors**

Used with Operator's Breast Plate Telephone Set with No. 20 Receiver and No. 18 Transmitter using No. 23 Plug, also Garford Type Operator's Plug.

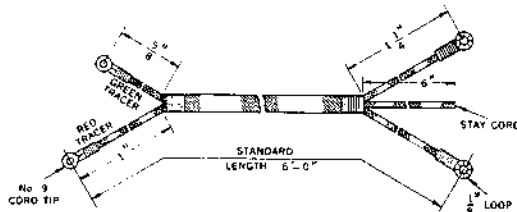

MO-2F

**800636 (MO-2-F) 6' 2 Conductors**  
 Used with Nos. 20 Operator's Receiver and 40 Plug.

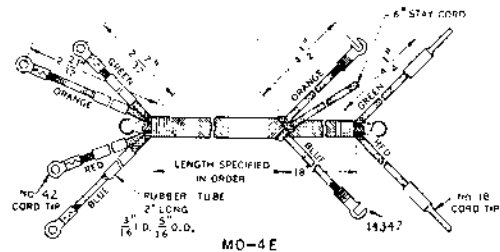

MO-4E

**800644 (MO-4-E) 5' 4 Conductors**

Used on W.E. Co's Operator's Sets (No. 87 or L-4-B) with Nos. 103, 112 or 137 Plugs.

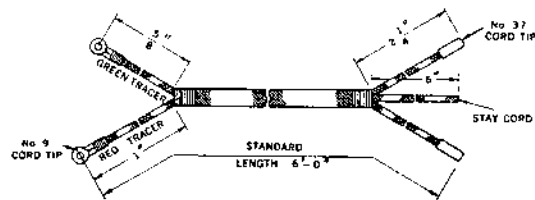

MO-2H

**800638 (MO-2-H) 6' 2 Conductors**  
 Used with No. 29 Operator's Receiver and No. 40 Plug.

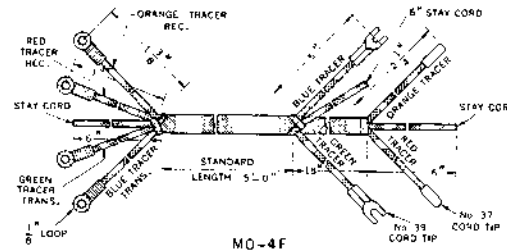

MO-4F

**800645 (MO-4-F) 5' 4 Conductors**  
**44273 (MO-4-F) 6' 4 Conductors**

Used with No. 4 Operator's Breast Plate Sets that have old style No. 23 Plug.

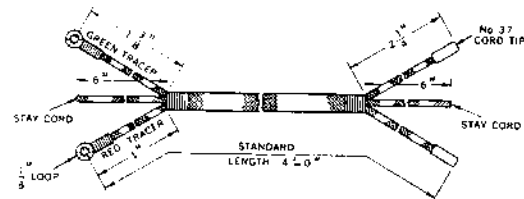

MO-2I

**44269 (MO-2-I) 4' 2 Conductors**  
 Used with No. 29 Receiver and No. 23 Plug.

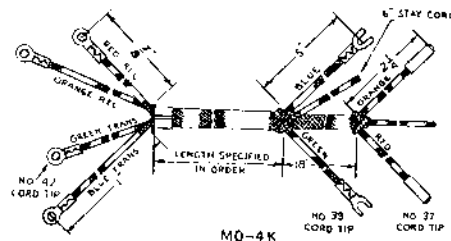

MO-4K

**201829 (MO-4-K) 5' 4 Conductors**  
**202245 (MO-4-K) 6' 4 Conductors**

Used with Operator's Breast Plate Sets that have new style No. 66 Plug.

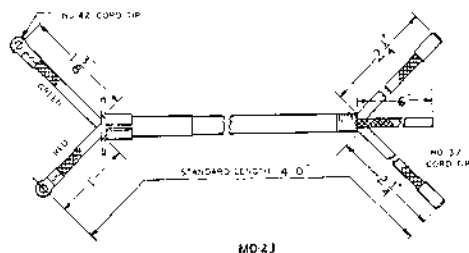

MO-2J

**202926 (MO-2-J) 4' 2 Conductors**  
 Used with No. 66 Plug and No. 29 Receiver.

DURATEX RECEIVER CORDS

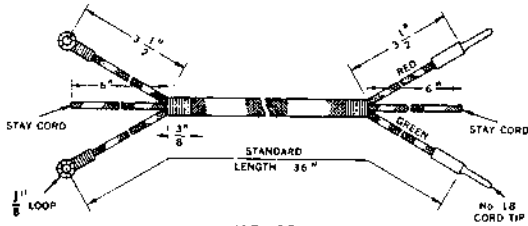

MR-2B

Stock No. Code Description  
 800650 (MR-2-B) 36" 2 Conductors  
 Brown Mercerized Cotton.

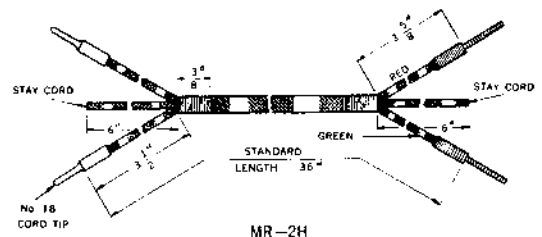

MR-2H

Stock No. Code Description  
 800653 (MR-2-H) 36" 2 Conductors  
 Brown Mercerized Cotton.

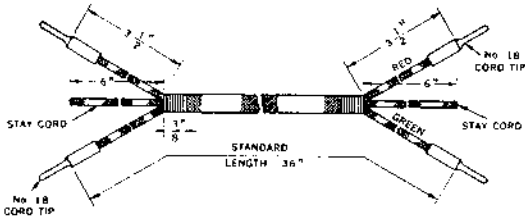

MR-2D

800651 (MR-2-D) 36" 2 Conductors  
 Brown Mercerized Cotton.

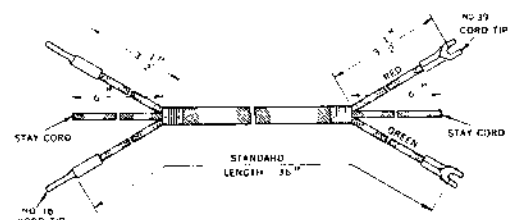

MR-2I

800654 (MR-2-I) 36" 2 Conductors  
 Brown Mercerized Cotton.

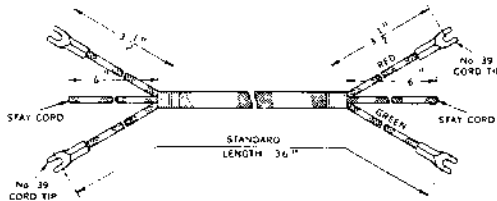

MR-2G

800652 (MR-2-G) 36" 2 Conductors  
 Brown Mercerized Cotton.  
 Used with No. 27-A Receiver.

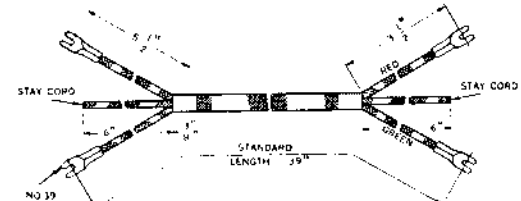

MR-2J

800655 (MR-2-J) 39" 2 Conductors  
 Brown Mercerized Cotton.  
 Used with No. 30-A Receiver.

DURATEX MISCELLANEOUS CORDS

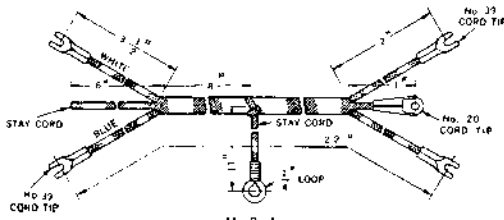

M-2-I

Stock No. Code Description  
 800627 (M-2-I) 22" 2 Conductors  
 Glazed Cotton Outer Braid. Used with Nos. 890 Mine-A-Phone  
 and 950 Iron Clad Telephone Receivers.

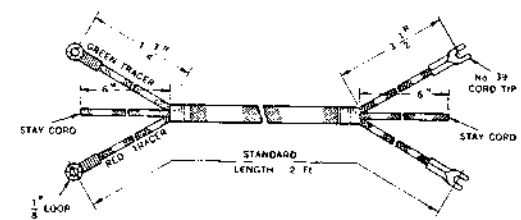

M-2-J

Stock No. Code Description  
 800626 (M-2-J) 24" 2 Conductors  
 Brown Cotton Mercerized Outer Braid. Used with No. 844  
 Test Set.

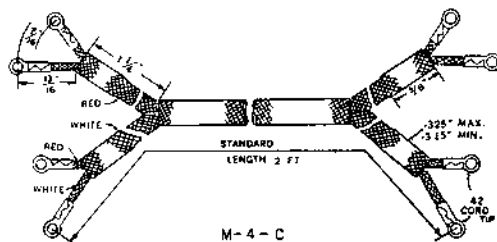

M-4-C

800628 (M-4-C) 24" 4 Conductors  
 Used with No. 62 Test Plug.

Stromberg-Carlson Duratex Cords of all types have met the test of service for over half a century. True economy can only be measured over a period of years. More and more telephone executives who think in terms of continuous operations have become convinced that there is no substitute for quality.

## DURATEX TERMINAL CORDS

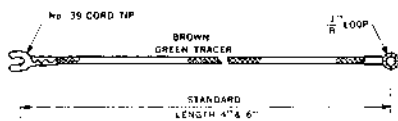

T-1-A

Stock No.	Code	Description
800656	(T-1-A) 6"	1 Tinsel Conductor
	(T-1-A) 4"	1 Tinsel Conductor

Used miscellaneously. Brown braid with green tracer.

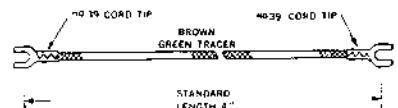

T-1-B

800657	(T-1-B)	4" 1 Tinsel Conductor
--------	---------	-----------------------

Used with No. 10 Transmitter. Brown braid with green tracer.

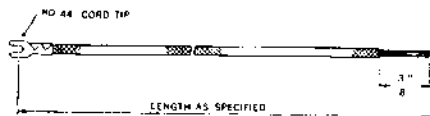

T-1-D

44155	(T-1-D)	9" 1 Stranded Conductor
-------	---------	-------------------------

Used miscellaneously. Brown braid.

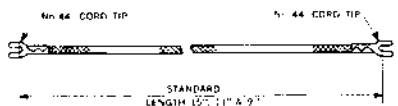

T-1-E

800659	(T-1-E)	9" 1 Stranded Copper Conductor
44174	(T-1-E)	11" 1 Stranded Copper Conductor
44175	(T-1-E)	15" 1 Stranded Copper Conductor

Used with No. 12, 13, 14 Handsets, No. 896 Tel. (9").

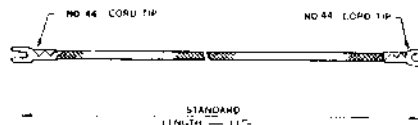

T-1-F

Stock No.	Code	Description
800660	(T-1-F)	11" 1 Stranded Copper Conductor

Brown braid with tracer.



T-1-G

800661	(T-1-G)	9" 1 Stranded Copper Conductor
44194	(T-1-G)	11" 1 Stranded Copper Conductor
44195	(T-1-G)	13" 1 Stranded Copper Conductor

Brown braid with tracer. Used on wall and desk telephones.



T-1-H

800662	(T-1-H)	9" 1 Tinsel Conductor
44354	(T-1-H)	11" 1 Tinsel Conductor
44355	(T-1-H)	15" 1 Tinsel Conductor

Brown braid with green tracer. Used miscellaneously.

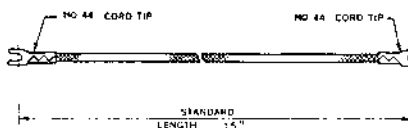

T-1-J

800663	(T-1-J)	15" 1 Stranded Copper Conductor
--------	---------	---------------------------------

Brown braid with red tracer. Used with handsets.

## M.D.F. TEST CORDS

M-6-D. This is a 6 Conductor Cord terminated on one end with No. 14 Cord tips, for attaching to a No. 35 or No. 38 Plug and with straight wire-wound conductors at the other end for use with Cook Nos. 8, 10, 21, 44, and 444 Test Plugs.

800630	(M-6-D)	15' Duratex Cord
--------	---------	------------------

M-6-E. This is a 6 Conductor Cord terminated on one end with No. 39 Cord tips, for connecting to screw terminals and with straight wire-wound conductors at the other end for use with Cook No. 3800 Test Plug.

800631	(M-6-E)	6' Duratex Cord
--------	---------	-----------------

M.D.F. Test Cords may be made in other lengths depending on test conditions. Prices for special lengths quoted on request.

## CORDAGE

Stromberg-Carlson Duratex Cordage covered with brown mercerized cotton is available to those who wish to make up their own cords in off-standard lengths.

Stock No.	Description
20118	Single Conductor Duratex Cordage
20101	Two Conductor Duratex Cordage
20102	Three Conductor Duratex Cordage
20114	Four Conductor Duratex Cordage
20115	Five Conductor Duratex Cordage

## COTTON SLEEVING

Brown cotton sleeving -- not waxed unless specified.

Stock No.	Inside Diameter	Feet Per Lb. Approx.
20031	3/64 in.	1250
20032	1/8 in.	380
20033	5/32 in.	300

STROMBERG-CARLSON

**GENERAL APPLICATION OF DURATEX CORDS**

The Switchboard and Instrument Cords shown on the preceding pages are standard for use with Stromberg-Carlson products. Many of them are the equivalent in application to cords made by other manufacturers. The list of Stromberg-Carlson replacements for such other cords which is shown below covers only those which are currently standard and therefore immediately available for our customer's convenience.

We believe that any type of cord made the Duratex way will more efficiently and economically serve our customer's needs. We have made and will continue to make cords to fit your own requirements. A complete sketch, or an actual sample, will aid in rendering this service promptly.

We invite a trial of Stromberg-Carlson cords, whether with our own equipment or the equipment of others, for this is the only convincing proof that money can actually be saved by the use of Duratex Switchboard and Instrument Cords.

**Stromberg-Carlson Replacements for Other Cords**  
(Specify length and color in the order)

**For Automatic Electric Co. Equipment**

To Replace Automatic Cord	Type	Order Stromberg-Carlson Cord
AD-43	Desk Stand	MD-2C
AD-44	Desk Stand	MD-2D
AD-45	Desk Stand	MD-3C
AD-46	Desk Stand	MD-3D
AH-14	Handset	MC-2B
DT-13	Operators	MO-1A
DA-14	Operators	MO-2F
DB-16	Operators	MO-4C
DS-43, 44, 45	Switchboard	S-22-B
DS-54, 55, 56	Switchboard	S-22-F
DS-46, 47, 48, 49	Switchboard	S-23-G
DS-34, 35, 36	Switchboard	S-23-P
DS-50, 51, 52, 53	Switchboard	S-32-K
DS-65	Switchboard	S-32-N
DS-61, 63	Switchboard	S-33-N5
DS-37, 38	Switchboard	SK-3450-5C
AR-19	Receiver	MR-2B
AR-20	Receiver	MR-2D
AR-21	Receiver	MR-2G
AR-22	Receiver	MR-2I
DT-12	Terminal	SK-3450-TA
DT-11	Terminal	SK-3450-TB

**For Runzel Cord and Wire Co. Products**

To Replace Runzel Cord	Type	Order Stromberg-Carlson Cord
37	Desk Stand	MD-3C
4	Switchboard	S-22-B
3	Switchboard	S-22-F
1	Switchboard	S-23-P
2	Switchboard	S-24-K
8	Switchboard	S-32-K
8A	Switchboard	S-33-N5
6	Switchboard	SK-3450-5C
7	Switchboard	SK-3450-5D
63	Receiver	MR-2B
61-A	Receiver	MR-2D
62	Receiver	MR-2G
61	Receiver	MR-2I
92	Terminal	T-1-B
93	Terminal	T-1-E
94	Terminal	T-1-G
90	Terminal	SK-3450-TA
91	Terminal	SK-3450-TB

**For Kellogg Switchboard and Supply Co. Equipment**

To Replace Kellogg Cord	Type	Order Stromberg-Carlson Cord
F-704-G	Handset	MC-3B
F-621-G	Handset	MC-3G
F-742-G	Handset	MC-4F
741-O	Operators	MO-4F
324-TO	Switchboard	S-22-F
301-TO	Switchboard	S-23-P
397-TO	Switchboard	S-24-K
326-TO	Switchboard	SK-3450-5C
309-TO	Switchboard	SK-3450-5D
390-TO	Switchboard	SK-3450-5E
391-TO	Switchboard	SK-3450-5F
F-642-TR	Receiver	MR-2I
499-T	Terminal	SK-3450-TA
465-T	Terminal	SK-3450-TB
F-730-D	Desk Stand	No. 203045

**For Western Electric Co. Equipment**

To Replace W. E. Cord	Type	Order Stromberg-Carlson Cord
D4U	Desk Stand	No. 42,897
D3AK	Desk Stand	No. 202,602
D5J	Desk Stand	No. 201,372
H3C	Handset	No. 202,601
H3P	Handset	MC-3H
I2K	Operator's	No. 202,249
S2A	Switchboard	SK-3453-5B
S2B	Switchboard	SK-3453-5C
S3A	Switchboard	SK-3453-5D
S3B	Switchboard	SK-3453-5E
437	Terminal	SK-3450-TB

## CORD ADJUSTERS

Provides a means to neatly adjust cord lengths so that cord weights hold cords taut. Made of black fibre — 4½ ins. long, by 1 in. wide.



No. 6 Cord Adjuster

Stock No.	Code	Description
12018	(6)	Standard 2 and 3 conductor switchboard cords.

## CORD FASTENERS

Brass punching — designed for drive-fit, through terminal rack, with tinned eyelet for soldering to switchboard cable, and screw terminal for connecting to switchboard cords. No. 36 Cord Tip fits either fastener.



No. 4 Cord Fastener



No. 5 Cord Fastener

Stock No.	Code	For Use On	Length
800667	(4)	Terminal Racks	1 15/16 in.
800668	(5)	Switchboards	1 3/8 in.

## CORD HOOKS

To suspend switchboard cords from tip of stay cord and thereby remove strain from conductors. No. 4 Type mounts hooks on ½ centers.

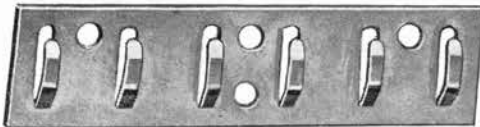

No. 4A Cord Hooks

Stock No.	Code	Description
7921	(2)	Standard switchboard cord, single hook
16008	(4-A)	Standard switchboard cords, six hooks
16357	(4-B)	Standard switchboard cords, four hooks
16358	(4-C)	Standard switchboard cords, two hooks

## CORD WEIGHTS

A standard Cord Weight for all types of regular switchboard cords, sufficiently heavy to restore cords to their respective places when plugs are withdrawn from jacks. Consists of a brass pulley wheel and a 9 oz. single pulley weight, armoured with steel casing. Dimensions — 4 x 1 29/32 x 3/8 in. Wheel — 7/8 x 1/4 in.



No. 6

Stock No.	Code	Description
800707	(6)	Cord Weight

## CORD TIPS

Cord tips are used to terminate cord and other conductors in a manner convenient for making electrical connections.



No. 9      No. 14      No. 17      No. 18

Stock No.	Code	Description
4877	(9)	For Nos. 10, 32, 42, 56, and 57 Type Plugs. Uses P-5729 or No. 2 Screw. Hole Drill — No. 43, Opening — 3/32 in.
5171	(14)	For Nos. 33, 34, 53, 54 and 55 Type Plugs. Uses P-8300 or No. 1 Screw. Hole Drill, No. 48. Opening — 3/64 in.
6916	(17)	Used on old style desk set cords. Connects to Magneto Desk Set Boxes using lock nut binding post. Spade opening 3/16 in. Fits Screws Nos. 8 or 10.
8312	(18)	For Stromberg-Carlson Receiver and Desk Set Cords and on telephone cords of other manufacture. Tip diameter — .081 in.



No. 20



No. 22



No. 25

Stock No.	Code	Description
8446	(20)	For switchboard cord, stay cord. Holds cords on cord hooks. Hole — 7/32 in.
8313	(22)	For transmitter cords connecting transmitter to telephone. Spade opening — 13/64 in. Fits No. 4 Screw.
8899	(25)	For stay cords. Connects cord to receiver cord tip.



No. 34



No. 35

Stock No.	Code	Description
28856	(34)	Used as Test Clip on Combination Telephone line cords.
11870	(35)	For desk and handset telephone cords. Spade opening — 1/8 in. Fits No. 4 Screw.



No. 36



No. 37

Stock No.	Code	Description
15377	(36)	For switchboard cord to cord fasteners on cord racks. Spade opening — 7/64 in. Fits Nos. 4 and 5 Cord Fasteners.
15642	(37)	Used on radio receiver cords and special cordage terminals.

CORD TIPS (Cont.)



No. 39

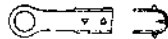

No. 40



No. 43

Stock No.	Code	Description
	(38)	Replaced by 33198 (39) Cord Tip.
33198	(39)	Used on desk, receiver and hand set cords. Non-soldering type. Connections are made by sharp tangs punched from the barrel of the tip which pierce the outer insulation and make contact with the metallic conductor. Nickel finish. Spade opening .126. Takes No. 4 screw.
38336	(40)	Non-soldering piercing type, used at plug end of switchboard cords. Screw hole drill size $\frac{3}{32}$ ", length $2\frac{7}{64}$ ". Takes No. 2 screw.

Stock No.	Code	Description
38334	(43)	Non-soldering piercing type, used on switchboard cords at cord fastener terminals. Spade opening slot $\frac{7}{64}$ ", length $1\frac{9}{32}$ ". Takes No. 4 screw.



No. 44



No. 45



No. 41

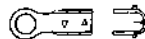

No. 42

Stock No.	Code	Description
38337	(41)	Non-soldering piercing type, used at plug end of switchboard cords. Screw hole drill size $\frac{3}{32}$ ", length $1\frac{7}{32}$ ". Takes No. 2 screw.
38338	(42)	Non-soldering piercing type, used at plug end of switchboard cords. Screw hole drill size $\frac{1}{8}$ ", length $2\frac{7}{64}$ ". Takes a No. 4 screw.

Stock No.	Code	Description
200947	(44)	Non-soldering piercing type, spade tip. Used on dial cords. Spade opening slot $\frac{1}{8}$ ", length $1\frac{9}{32}$ ". Takes No. 4 screw.
200948	(45)	Non-soldering piercing type, eyelet tip. Used on dial cords. Screw hole drill size $\frac{1}{8}$ ", length $3\frac{7}{64}$ ". Takes No. 4 screw.

Consult your nearest Stromberg-Carlson representative for advice on combining orders to take advantage of quantity price discounts.



# GENERAL INDEX—EQUIPMENT DIVISION

FOR ITEMS LISTED IN SECTIONS "a" THROUGH "g"

## A

Adapters, Transmitter . . . . .	78f
Apparatus Blanks (See Blanks)	
Arms, Transmitter . . . . .	78f

## B

Batteries, Dry Cell (See Supply Division)	
Bells, Loud Ringing (See Supply Division)	
Blanks	
Drop . . . . .	16f
Jack . . . . .	28f
Key . . . . .	3f
Plug Hole . . . . .	52f
Blocks, Terminal (Tel.) . . . . .	73f
Boxes	
Battery (See Supply Division)	
Jack (Outlet) . . . . .	24f
Key (Switching) . . . . .	43f
Terminals . . . . .	73f
Brackets, Foot Rail . . . . .	18f
Bus Bars (See Distributing Bars) . . . . .	14f
Buzzers	
Switchboard . . . . .	70f
Telephone . . . . .	72f
Miniature . . . . .	72f

## C

Cable	
Switchboard (See Supply Division)	
Cable Rack, Magneto . . . . .	11b
Calculagraphs (See Supply Division)	
Cam Keys . . . . .	29f
Capacitors (See Condensers) . . . . .	11f
Caps (Sleeves) Trouble . . . . .	52f
Caps (Lamp) . . . . .	46f
Capsule Receiver . . . . .	54f
Transmitter . . . . .	76f
Card Frames . . . . .	45f
Casings (Relay) . . . . .	65f
Central Office Protectors . . . . .	11b
Central Office Switchboards	
Magneto . . . . .	4b
Chairs, Operators (See Supply Division)	
Clear-Out Drops . . . . .	15f
Coils	
Drop . . . . .	15f

## Coils (Continued)

Heat (Protector) (See Supply Division)	
Impedance . . . . .	4f
Induction . . . . .	7f
Ind. Coil & Condenser Block . . . . .	12f
Kick . . . . .	12b
Phantom . . . . .	8f
Repeating . . . . .	8f
Resistance . . . . .	10f
Retardation (See Impedance Coils) . . . . .	4f
Ringer . . . . .	68f
Combined Drop and Jack . . . . .	15f
Common Battery Telephones	
Iron-Clad . . . . .	10a
C. B. Telephones on Magneto Lines . . . . .	12b
Condensers . . . . .	11f
Condenser-Coil Block . . . . .	7f
Condenser Mountings . . . . .	12f
Cords, Duratex (Section g)	
Convenience Systems . . . . .	10g
Desk Set . . . . .	8g
Handset . . . . .	10g
MDF Testing . . . . .	14g
Miscellaneous . . . . .	13g
Operator's . . . . .	12g
Receiver . . . . .	13g
Retractable (See Supply Division)	
Switchboard . . . . .	3g
Terminal Cords . . . . .	14g
Cordage . . . . .	14g
Cord Adjusters . . . . .	16g
Cord Fasteners . . . . .	16g
Cord Hooks . . . . .	16g
Cord Terminals . . . . .	16g
Cord Weights . . . . .	16g
Cotton Sleeving . . . . .	14g

## D

Designation Strips . . . . .	13f
Desk Set Boxes, Magneto . . . . .	8a
Dial Mountings . . . . .	14f
Dischargers (Protectors) (See Supply Division)	
Distributing Bars . . . . .	14f
Drop Signals	
Line . . . . .	15f
Clear-Out . . . . .	15f

GENERAL INDEX—EQUIPMENT DIVISION (Cont.)

Drop Blanks . . . . . 16f  
 Drop Mountings . . . . . 16f  
 Drops (Former Types) . . . . . 17f  
 Dry Cells (See Supply Division)

**E**

Eliminators, Battery (See Supply Division)  
 Extension Bells  
     Loud Ringing (See Supply Division)

**F**

Fasteners, Cord . . . . . 16g  
     Jack . . . . . 28f  
 Foot Rails . . . . . 18f  
 Foot Rail Brackets . . . . . 18f  
 Frames  
     Card . . . . . 45f  
     Protector, Magneto . . . . . 11b  
 Fuses  
     Indicator Alarm . . . . . 18f  
     Mica (See Supply Division)  
     Protection . . . . . 18f  
     Tubular (See Supply Division)

**G**

Gauges, Plug & Jack . . . . . 52f  
 Generators, Hand . . . . . 19f  
     Iron-Clad (Hand) . . . . . 20f  
 Generators (Former Types) . . . . . 20f  
 Generator Protection Lamp Sockets . . . . . 47f  
 Gongs (Telephone) . . . . . 18f

**H**

Hand Generators . . . . . 19f  
 Hand Generator, Iron-clad . . . . . 20f  
 Hand Receivers . . . . . 53f  
 Handset Telephones  
     With Kick Coils . . . . . 12b  
     Magneto . . . . . 4a  
 Heat Coils (See Supply Division)  
 Holly Strips . . . . . 20f  
 Hooks, Cord . . . . . 16g

Hooks (Receiver) . . . . . 21f  
 Hookswitches . . . . . 21f  
 Hookswitch Box . . . . . 9a

**I**

Impedance Coils . . . . . 4f  
 Impedance Coil Mtgs. . . . . 6f  
 Indicating Keys . . . . . 36f  
 Indicator Alarm Fuses . . . . . 18f  
 Induction Coils . . . . . 7f  
 Iron-Clad Equipment  
     Generator . . . . . 20f  
     Telephones . . . . . 10a

**J**

Jacks  
     Individual . . . . . 22f  
     Strip Type . . . . . 24f  
     Operators . . . . . 22f  
     Test . . . . . 23f  
     Toll Test . . . . . 23f  
     Wall Outlet . . . . . 24f  
 Jack Blanks . . . . . 28f  
 Jack Fasteners . . . . . 28f  
 Jack Gauges . . . . . 52f

**K**

Keys, Cam  
     170 Type . . . . . 34f  
     340 Type . . . . . 29f  
     Combined Key & Drop . . . . . 35f  
 Keys, Individual  
     Push Plunger . . . . . 41f  
     Push Button . . . . . 41f  
     Super-Service . . . . . 40f  
     Twist Plunger . . . . . 41f  
 Keys in Strips  
     Plunger Type . . . . . 40f  
 Keys, Party Line Indicating . . . . . 36f  
 Keys, Former Types . . . . . 39f  
 Key Blanks . . . . . 3f  
 Key Boxes . . . . . 43f  
 Key Designations . . . . . 13f  
 Key Mountings . . . . . 42f  
 Kick Coils . . . . . 12b

GENERAL INDEX—EQUIPMENT DIVISION (Cont.)

**L**

Lamps, Switchboard . . . . . 45f

Lamp Caps . . . . . 46f

Lamp Jacks (See Lamp Sockets)

Lamp Signal Switchboard (Magneto Type) 10b

Lamp Sockets

    Individual . . . . . 47f

    Strips . . . . . 47f

    Generator Protection . . . . . 47f

Loud Ringing Bells (See Supply Division)

**M**

Magneto Protector Frame . . . . . 11b

Magneto Switchboards

    No. 125 (Floor Type) . . . . . 4b

    No. 126 (Wall Type) . . . . . 9b

    A-11740 (Wall Type) . . . . . 9b

    No. 115 (Lamp Signal) . . . . . 10b

Magneto Lines with

    Common Battery Telephones . . . . . 12b

Magneto Telephones

    Desk Type Handsets

        1244 (For Desk Set Box) . . . . . 8a

        1248 (Self-Contained) . . . . . 4a, 5a, 7a

        1258 Wall Set . . . . . 6a

        1268 Desk Set Box . . . . . 8a

        890 Iron-Clad . . . . . 10a

Manual Switchboards (See Section b)

Master Party Line Keys . . . . . 39f

Message Registers (See Supply Division)

Mounting Plates

    Condenser . . . . . 12f

    Drop . . . . . 16f

    Impedance Coil . . . . . 6f

    Key . . . . . 42f

    Relay . . . . . 66f

    Toll Test Jack . . . . . 24f

    Visual Signal . . . . . 78f

Multiple Contact Relays . . . . . 65f

**N**

Number Plates . . . . . 48f

**O**

Operator's Chairs (See Supply Division)

Operator's Telephone Sets . . . . . 49f

Operator's Cords . . . . . 12g

    Jacks . . . . . 22f

    Plugs . . . . . 51f

    Receiver . . . . . 53f

    Transmitter . . . . . 77f

Operator's Receivers

    Former Types . . . . . 53f

**P**

Party Line Keys . . . . . 37f

Phantom Coils . . . . . 8f

Plates (Number) . . . . . 48f

Plugs, Operator's

    Outlet Box . . . . . 51f

    Service . . . . . 52f

    Switchboard . . . . . 50f

    Test . . . . . 51f

Plugs, Former Types . . . . . 51f

Plug and Jack Gauges . . . . . 52f

Plug Hole Blanks . . . . . 52f

Plug Seats . . . . . 52f

Plug Trouble Caps . . . . . 52f

Plunger Type Keys

    Individual . . . . . 41f

    Strip Type . . . . . 40f

Protector Frames

    Magneto . . . . . 11b

Protectors (Also See Supply Division)

    Central Office . . . . . 11b

    Sub-Station (See Supply Division)

Protection Fuses . . . . . 18f

Push Button Keys . . . . . 40f

**R**

Rack, Cable (Magneto) . . . . . 11b

Rail, Foot . . . . . 18f

Receivers

    Handset . . . . . 54f

    Operator's . . . . . 53f

    Sub-Station . . . . . 53f

Registers, Message (See Supply Division)

Relays, Relay Coils

    No. 190 Type . . . . . 55f

    No. 200 Type . . . . . 56f

    No. 300 Type . . . . . 58f

GENERAL INDEX—EQUIPMENT DIVISION (Cont.)

Relays (Continued)	
No. 500, 600 Types . . . . .	63f
No. 720 Type . . . . .	65f
"A" and "B" Types . . . . .	60f
Relay Casings . . . . .	65f
Relay Mountings . . . . .	66f
Repeating Coils . . . . .	8f
Resistance Coils . . . . .	10f
Retardation Coils (See Impedance Coils) . . . . .	4f
Ringers, Telephone	
Small Type . . . . .	67f
Large Type . . . . .	71f
Former Types . . . . .	72f
Ringers	
Switchboard (Buzzer Type) . . . . .	70f
Switchboard (Line Ringer) . . . . .	69f
Test Sets (Buzzer Type) . . . . .	72f
<b>S</b>	
Seats, Plug . . . . .	52f
Service Plugs . . . . .	52f
Signals, Line	
Drop . . . . .	15f
Lamp . . . . .	45f
Ringer . . . . .	69f
Visual . . . . .	78f
Signals, Clear-Out . . . . .	15f
Sleeves, Trouble . . . . .	52f
Sleeving, Cotton . . . . .	14g
Sockets, Lamp . . . . .	47f
Strips, Mounting (See Mounting Plates)	
Strips	
Designation . . . . .	13f
Holly . . . . .	20f
Terminal . . . . .	73f
Switches, Hook . . . . .	21f
Switches, Knife (See Supply Division)	
Switches, Key (See Keys)	
Switchboards	
Central Office Switchboards	
Magneto Types	
No. 115 (Lamp) . . . . .	10b
No. 125 (Drop) . . . . .	4b
No. 126 (Drop) . . . . .	9b
No. 11740 (Ringer) . . . . .	9b

Switchboard Cable (See Supply Division)	
Switchboard Chairs (See Supply Division)	
Switchboard Cords . . . . .	3g
Switchboard Lamps . . . . .	45f
Switchboard Tools . . . . .	74f

**T**

Telephone Instruments—Magneto	
Iron-Clad Type . . . . .	10a
Suspended Type . . . . .	9a
Desk Type, Two-Piece . . . . .	8a
Desk Type, Self-Contained . . . . .	4a
Wall Type . . . . .	6a
Desk Set Box . . . . .	8a
Former Types . . . . .	12a
Telephone Sets, Operators . . . . .	49f
Terminal Blocks . . . . .	73f
Terminal Boxes . . . . .	73f
Terminal Strips . . . . .	73f
Terminals, Cord . . . . .	16g
Test Jacks (Cord, Toll) . . . . .	23f
Test Plugs . . . . .	51f
Test Sets, Linesmen (See Supply Division)	
Tips, Cord . . . . .	16g
Toll Test Jacks . . . . .	23f
Tools, Swbd. & Misc. . . . .	74f
Transmitters	
Operator's . . . . .	77f
Telephone . . . . .	76f
Test Set . . . . .	77f
Former Types . . . . .	76f
Transmitter Adapters . . . . .	78f
Transmitter Arms . . . . .	78f
Transmitter Cords . . . . .	12g
Trouble Caps (Sleeves) . . . . .	52f

**V**

Visual Signals . . . . .	78f
--------------------------	-----

**W**

Wall Telephones	
Magneto . . . . .	6a
Weights, Cord . . . . .	16g

## GENERAL INDEX-SUPPLIES DIVISION

FOR ITEMS LISTED IN SECTIONS "m" THROUGH "w"

### A

Accessories, Pay Station . . . . .	8u, 9u
Acetylene Tanks, Prest-O-Lite . . . . .	36t
Acid Core Solder . . . . .	19p
Adler Carrier Systems . . . . .	3v, 4v, 5v, 6v
Aerial Cable Feeders and Straighteners . . . . .	8p
Cable Splicers Tents . . . . .	13p
Cable Supports . . . . .	14p
Cable and Wire Tensioning Jacks . . . . .	18t
Underground Terminals . . . . .	6q
Air Cells . . . . .	18q
Alley Arm Braces . . . . .	17m
Alligator Clips . . . . .	14w
Knobs . . . . .	.6s
Aluminum Letters and Figures . . . . .	11m
Ammeters . . . . .	37t, 38t
Amplifiers, Carrier Systems . . . . .	5v
Anchor Rods, Ball Point . . . . .	4m
Threaded . . . . .	4m
<b>Anchors</b>	
Cone . . . . .	3m
Drive, Hammer . . . . .	17w
Expanding . . . . .	3m, 4m
Never-Creep . . . . .	3m
Screw . . . . .	18w
Steelwing . . . . .	5m
Angle Bolts . . . . .	13m
Braces . . . . .	17m
Screws . . . . .	.6s
Anhydrous Prepared Cotton Sleeves . . . . .	16p
Apparatus Blank Assemblies, Pay Station . . . . .	9u
Arming Bolts, Double . . . . .	13m
Arms, Cross . . . . .	5n
<b>Arresters</b>	
Crossarm . . . . .	8q
Indoor . . . . .	10q
Lightning . . . . .	8q, 10q
Outdoor . . . . .	8q
Auger Bits . . . . .	29t
Blades . . . . .	7t
Handles, Telescope . . . . .	7t
<b>Augers</b>	
Earth . . . . .	7t
Telescoping . . . . .	7t
Automatic (Push) Drills . . . . .	30t

### B

Back Braces . . . . .	16m, 17m
Bags, Rubber Glove, Linemen's . . . . .	11w
Tool . . . . .	24t, 25t
Balconies, Pole . . . . .	20m
Ball Pein Hammers . . . . .	26t

Bands, Cable Reinforcing . . . . .	15m
Bar Solder . . . . .	19p
Barrow Reels . . . . .	11t
Bars, Crow and Digging . . . . .	.6t
Digging . . . . .	.6t
Expanding and Tamping . . . . .	.7t
Tamping . . . . .	.6t
<b>Batteries</b>	
Dry . . . . .	17q, 18q
Unit Type . . . . .	17q, 18q
Battery Boxes . . . . .	16q
Eliminators . . . . .	21w
Beeswax Compound . . . . .	16p
Bell Hangers' Drills . . . . .	29t
Bells, Loud Ringing . . . . .	6w
Belt Support . . . . .	23t
<b>Belts</b>	
Linemens' . . . . .	21t, 22t, 23t
Tool . . . . .	21t, 22t, 23t
Bench Grinder . . . . .	34t
Benders, Cable . . . . .	9p
Big Beam Lamps . . . . .	8w
<b>Bills</b>	
Subscribers' . . . . .	8w
Toll . . . . .	8w
Binders, Load . . . . .	18t
Bisectors (Pole Sights) . . . . .	35t
Bit Braces . . . . .	32t
Extensions . . . . .	32t
<b>Bits</b>	
Auger . . . . .	29t
Car . . . . .	28t, 29t
Crossarm . . . . .	28t
Pole . . . . .	28t
Screwdriver . . . . .	32t, 33t
<b>Blades</b>	
Auger . . . . .	.7t
Saw, Hack . . . . .	.5t
Blake Staples, Insulated . . . . .	15w
Blank Forms, Telephone Operating . . . . .	8w
<b>Blanks</b>	
Pay Roll . . . . .	8w
Record . . . . .	8w
Record, Daily Work . . . . .	8w
Report, Monthly Check . . . . .	8w
Sub-Voucher . . . . .	8w
Voucher . . . . .	8w
<b>Blocks</b>	
Connecting . . . . .	9q
Discharge, Sawtooth . . . . .	8q
Pulley . . . . .	19t
Tackle . . . . .	17t
Blow Torches . . . . .	20p, 21p, 22p

GENERAL INDEX—SUPPLIES DIVISION (Cont.)

<b>Blow-Rite Fuse Wire</b> . . . . .	13q
Fuses . . . . .	13q
<b>Boards, Test, Linen</b> . . . . .	6p
<b>Bolt Cutters</b> . . . . .	27t
<b>Bolts</b>	
Angle . . . . .	13m
Bracket . . . . .	12m
Carriage . . . . .	12m
Cross Arm . . . . .	12m
Double Arming . . . . .	13m
Eye . . . . .	13m, 14m
Fork, Insulated . . . . .	.7s
Hook, Crossover Bracket . . . . .	16m
Hubeye . . . . .	13m
Lag (Screws) . . . . .	12m
Machine . . . . .	12m
Straight Hubeyes . . . . .	14m
Through . . . . .	12m
Toggle . . . . .	18w, 19w
<b>Bonding Ribbon</b> . . . . .	17p
<b>Booths, Telephone</b> . . . . .	5u, 6u
<b>Boxes</b>	
Battery . . . . .	16q
Interior Junction . . . . .	12q
Stuffing, Cable Terminal . . . . .	5q
Terminal, Building . . . . .	11q
<b>Boxwood Rules</b> . . . . .	33t
<b>Brace Drills, Wood Boring</b> . . . . .	28t
<b>Braces</b>	
Alley Arm . . . . .	17m
Angle . . . . .	17m
Back . . . . .	16m
Bit . . . . .	32t
Cross Arm . . . . .	17m
Diagonal . . . . .	16m
Vertical . . . . .	16m, 17m
<b>Bracket Bolts</b> . . . . .	12m
Clip Washers . . . . .	6n
<b>Brackets</b>	
Corner, Galvanized . . . . .	14m
Corner, Pay Station . . . . .	9u
Corner, Presteel . . . . .	19m
Corner, Telephone . . . . .	14m
Crossover, Highway . . . . .	16m
Dead End . . . . .	.7s
Distributing . . . . .	14m
House . . . . .	14m, 19m
Pay Station . . . . .	9u
Pole . . . . .	18m, 19m
Shelf, Pay Station . . . . .	9u
Straps . . . . .	6n
Transposition . . . . .	18m, 19m
Wood . . . . .	5n
<b>Braid Strippers</b> . . . . .	15t

<b>Brazing Outfits, Prest-O-Lite</b> . . . . .	36t
<b>Breast Drills</b> . . . . .	31t
Plates . . . . .	9m
<b>Bridge Test Sets, Fault Location</b> . . . . .	40t
<b>Bridging Connectors</b> . . . . .	13w
<b>Bridle Rings</b> . . . . .	17w
Wire . . . . .	4r, 6r
<b>Broad Hatchets</b> . . . . .	27t
<b>Buckets</b>	
Canvas . . . . .	25t
Non-Metallic, Collapsible . . . . .	25t
<b>Buffalo Grips</b> . . . . .	16t
<b>Building Terminal Boxes</b> . . . . .	11q
Terminals . . . . .	12q
<b>Buried Wire Terminals</b> . . . . .	9q
<b>Burnishing Paste</b> . . . . .	17p
<b>Buzzers</b> . . . . .	6w

C

<b>C-A Wood Preserver</b> . . . . .	6n
<b>C-B Knobs, Drop Wire</b> . . . . .	.6s
<b>C-R Connectors, Service</b> . . . . .	13w
<b>Cabinet Booths, Telephone</b> . . . . .	5u
<b>Cable</b>	
Convenience Systems . . . . .	4p
Generator . . . . .	5p
Inter-Comm . . . . .	4p
Lead Covered . . . . .	3p, 4p
Switchboard . . . . .	5p, 6p
Toll . . . . .	5p
<b>Cable Benders</b> . . . . .	9p
Cars, Safety, Linemen's . . . . .	10p
Clamps . . . . .	14p
Compound . . . . .	17p
Conduit . . . . .	6p
Duct Shields . . . . .	10p
Feeders and Straighteners, Aerial . . . . .	8p
Grips . . . . .	15p
Hangers . . . . .	14p
Insulating Sleeves . . . . .	16p
Lashing wire . . . . .	12p
Locator . . . . .	38t
Pasters . . . . .	20p
Rack Hook Insulators, Underground . . . . .	10p
Rack Hooks, Underground . . . . .	10p
Racks, Underground . . . . .	10p
Reel Jacks . . . . .	8p
Ring Saddles . . . . .	13p
Rings . . . . .	13p
Rollers . . . . .	11p
Saws . . . . .	.5t
Sheath Splitting Knives . . . . .	20p
Slitter . . . . .	11p
Spinners . . . . .	11p, 12p

GENERAL INDEX—SUPPLIES DIVISION (Cont.)

Splicers' Tents, Aerial . . . . .	13p	Cross-Over . . . . .	6m
Straps . . . . .	14p	Drop Wire . . . . .	12w
Supports . . . . .	14p	Grade . . . . .	8m
Suspension Clamps . . . . .	8m, 19m	Ground, Station . . . . .	6m
Terminals . . . . .	3q, 4q, 5q, 6q, 13q	Ground Rod . . . . .	5m, 6m
Testers . . . . .	38t	Guy . . . . .	7m
U Guards . . . . .	15m	Kling . . . . .	6m
<b>Cable and Wire Tensioning Jacks</b> . . . . .	18t	Span . . . . .	7m
<b>Cablemen's Thermometers</b> . . . . .	17p	Splicing . . . . .	15t
<b>Calculagraph Pedestals</b> . . . . .	7w	Suspension, Cable . . . . .	8m, 19m
Ribbons . . . . .	7w	Wedge-Tite . . . . .	14w
Transformers . . . . .	7w	Wire . . . . .	15t
<b>Calculagraphs</b> . . . . .	7w	Wire and Sleeve . . . . .	15t
<b>Candles</b>		<b>Clay Conduit</b> . . . . .	7p
Plumbers' . . . . .	16p	<b>Cleaners, Vacuum</b> . . . . .	5w
Wickless . . . . .	16p	<b>Clevises, Insulated</b> . . . . .	6s, 7s
<b>Cant Hook Handles</b> . . . . .	9t	<b>Climber Pads</b> . . . . .	20t
Hooks . . . . .	9t	Straps . . . . .	20t
<b>Canvas Buckets</b> . . . . .	25t	<b>Climbers</b> . . . . .	21t, 22t
<b>Car Bits</b> . . . . .	28t, 29t	<b>Clip Tools, Guy Wire</b> . . . . .	12w
<b>Carbolineum</b> . . . . .	6n	Washers, Bracket . . . . .	6n
<b>Carbon, Arrester and Protector</b> . . . . .	8q, 11q	<b>Clippers, Bolt</b> . . . . .	27t
<b>Card Holder Assemblies, Pay Station</b> . . . . .	9u	Hedge . . . . .	4t
<b>Carriage Bolts</b> . . . . .	12m	<b>Clips</b>	
<b>Carrier Systems</b> . . . . .	3v, 4v, 5v, 6v	Alligator . . . . .	14w
<b>Carrying Hook Handles</b> . . . . .	9t	Crosby . . . . .	7m
Hooks . . . . .	9t	Drop Wire . . . . .	12w, 13w
<b>Cars, Safety Cable</b> . . . . .	10p	Guy . . . . .	12w
<b>Cases, Tool, Hip Pocket</b> . . . . .	22t, 23t	Test . . . . .	14w, 15w
<b>Cash Books</b> . . . . .	8w	Vise . . . . .	7m
Compartment Door Locks, Pay Station . . . . .	8u	Wire, Guy . . . . .	12w
<b>Castings, Reinforcing</b> . . . . .	15m	Wire Rope . . . . .	7m
<b>Catch Cloths</b> . . . . .	18p	<b>Clothing, Rubber</b> . . . . .	11w
<b>Cells, Dry</b> . . . . .	17q, 18q	<b>Cloths</b>	
<b>Central Office Protectors</b> . . . . .	15q, 16q	Catch . . . . .	18p
<b>Chain Hoists</b> . . . . .	17t, 18t, 19t	Wiping . . . . .	18p
Tapes . . . . .	33t	<b>Coil, Repeating</b> . . . . .	14q
<b>Chairs, Aerial (Cars)</b> . . . . .	10p	<b>Coil Protectors and Housing</b> . . . . .	14q
Posture, Operators' . . . . .	3u, 4u	<b>Coils Heat</b> . . . . .	12q, 13q
<b>Chicago Grips</b> . . . . .	16t	<b>Coin Receptacles, Pay Station</b> . . . . .	9u
Linemen's Tools . . . . .	16t	<b>Cold Chisels</b> . . . . .	33t
<b>Chisels</b>		<b>Collapsible Non-Metallic Buckets</b> . . . . .	25t
Cold . . . . .	33t	<b>Columbia Dry Cells</b> . . . . .	17q
Framing, Socket . . . . .	26t	<b>Common Nails</b> . . . . .	19w
<b>Chucks and Points, Drill</b> . . . . .	31t	<b>Commutator Burnishing Paste</b> . . . . .	17p
<b>Clamps</b>		<b>Compound</b>	
Cable . . . . .	14p, 15p	Beeswax . . . . .	16p
Conduit . . . . .	14p, 15p		

GENERAL INDEX—SUPPLIES DIVISION (Cont.)

Cable . . . . .	17p
<b>Conduit</b>	
Cable . . . . .	6p, 7p
Clay . . . . .	7p
Fibre . . . . .	6p
Wood, Creosoted . . . . .	7p
<b>Conduit Clamps</b> . . . . .	14p
Joint Tape . . . . .	6p
Straps . . . . .	14p
<b>Cone Anchors</b> . . . . .	3m
<b>Connecting Blocks</b> . . . . .	9q
<b>Con-Nect-Tites, Telephone</b> . . . . .	13w
<b>Connectors</b>	
Bridging . . . . .	13w
Service . . . . .	13w
Strand . . . . .	18w
Testerm, Drop Wire . . . . .	9q
<b>Construction Wire</b> . . . . .	7r
<b>Convenience Systems Cable</b> . . . . .	4p
<b>Coppers, Soldering</b> . . . . .	20p
Soldering Handles . . . . .	20p
<b>Copperweld Line Wire</b> . . . . .	8r
Strand . . . . .	9r
<b>Cord, Retractable</b> . . . . .	11w
<b>Corner Brackets, Galvanized</b> . . . . .	14m
Brackets, Pay Station . . . . .	9w
Brackets, Presteel . . . . .	19m
Brackets, Telephone . . . . .	14m
Pins . . . . .	6n
<b>Cotton Sleeves</b> . . . . .	16p
<b>Counters, Telephone</b> . . . . .	5w
<b>Cover Hooks, Manhole</b> . . . . .	9p
<b>Covers and Frames, Manhole</b> . . . . .	9p
<b>Crapo Strand, Galvanized Steel</b> . . . . .	9r
Wire . . . . .	7r, 8r, 9r
<b>Creosoted Wood Conduit</b> . . . . .	7p
<b>Crocodile Clips</b> . . . . .	14w
<b>Crosby Clips</b> . . . . .	7m
<b>Cross Arm Arresters</b> . . . . .	8q
Bits . . . . .	28t
Bolts . . . . .	12m
Braces . . . . .	17m
<b>Cross Arms</b> . . . . .	5n
<b>Crossover Bracket Hook Bolts</b> . . . . .	16m
Brackets, Highway . . . . .	16m
Clamps . . . . .	6m
<b>Crow and Digging Bars</b> . . . . .	6t

<b>Current Flow Test Sets</b> . . . . .	41t
<b>Curved Lift Plates</b> . . . . .	10m
Washers . . . . .	11m
<b>Cutters, Bolt</b> . . . . .	27t

**D**

<b>Dating Nails, Pole</b> . . . . .	11m
<b>Dead-Ends</b> . . . . .	7s, 11s
<b>Deadmen</b> . . . . .	10t
<b>Desiccant, Protek-Sorb.</b> . . . . .	18p
<b>Detecto-Meters</b> . . . . .	37t
<b>Diagonal Braces</b> . . . . .	16m
<b>Digger Handles</b> . . . . .	7t
<b>Diggers, Post Hole</b> . . . . .	6t, 7t
<b>Digging Bars</b> . . . . .	6t
Spuds . . . . .	6t
<b>Discharge Blocks, Sawtooth</b> . . . . .	8q
<b>Dischargers, Tru-Gap</b> . . . . .	11q
<b>Distributing Brackets</b> . . . . .	14m
Frames . . . . .	14q, 15q
Knob Racks . . . . .	7s
Wire, Outside . . . . .	3r, 4r, 5r, 6r
<b>Double Arming Bolts</b> . . . . .	13m
Arming Eyebolts . . . . .	13m
Tube Splicing Sleeves . . . . .	8s
<b>Dowel Pins.</b> . . . . .	6p
<b>Draw Knives</b> . . . . .	28t
<b>Dressers, Hardwood.</b> . . . . .	18p
<b>Drift Plugs</b> . . . . .	20p
<b>Drill Holders</b> . . . . .	27t
Points and Chucks . . . . .	31t
<b>Drills</b>	
Automatic (Push) . . . . .	30t
Bell Hangers' . . . . .	29t
Brace, Wood Boring . . . . .	28t
Breast . . . . .	31t
Electric . . . . .	34t, 35t
4-Point . . . . .	28t
Hand . . . . .	31t
Masonry . . . . .	28t
Radio . . . . .	31t
Star . . . . .	28t
Twist . . . . .	27t
<b>Drive Anchors, Hammer</b> . . . . .	17w
Hooks . . . . .	12w
Rings . . . . .	17w
<b>Drivers, Screw</b> . . . . .	29t, 30t, 31t, 32t

GENERAL INDEX—SUPPLIES DIVISION (Cont.)

Staple . . . . .	6w
<b>Drop Wire</b> . . . . .	6w
<b>Drop Wire Clamps</b> . . . . .	12w
Clips . . . . .	13w
Connectors . . . . .	9q
Grips . . . . .	12w
Hooks . . . . .	13w
Knobs . . . . .	.6s
<b>Drum Jacks</b> . . . . .	8p
<b>Dry Batteries</b> . . . . .	17q, 18q
<b>Dry Spot</b> . . . . .	14w
<b>Drying Material (Desiccant)</b> . . . . .	18p
<b>Duct Shields, Cable</b> . . . . .	10p
<b>Dynamometers</b> . . . . .	35t

**E**

<b>Earth Augers</b> . . . . .	.7t
<b>Electric Digging Spuds</b> . . . . .	.6t
Drills . . . . .	34t, 35t
Hammers and Drills . . . . .	35t
Light Arms . . . . .	5n
Tamping Bars . . . . .	.6t
<b>Electricians' Knives</b> . . . . .	.4t
Scissors . . . . .	15t
<b>Electrox Rectifiers</b> . . . . .	21w
<b>Eliminators, Battery</b> . . . . .	21w
<b>Enamel, Dull Black</b> . . . . .	5w
<b>Enclosed Fuses</b> . . . . .	13q
<b>Escutcheon Pins</b> . . . . .	11m
<b>Eveready Batteries</b> . . . . .	17q, 18q
<b>Expanding Anchors</b> . . . . .	3m, 4m
<b>Expanding and Tamping Bars</b> . . . . .	.7t
<b>Expansion Shields</b> . . . . .	17w
<b>Extension Fixtures, Side, Pole</b> . . . . .	16m
Ladders . . . . .	12t
<b>Extensions, Bit</b> . . . . .	32t
<b>Extinguishers, Fire</b> . . . . .	6w
<b>Eye Nuts</b> . . . . .	14m
<b>Eyebolts, Standard</b> . . . . .	13m
Double Arming . . . . .	13m
Oval Eye . . . . .	13m
<b>Eyes</b>	
Bolt . . . . .	13m, 14m
Screw, Insulated . . . . .	.6s

**F**

<b>Factory Howlers</b> . . . . .	3w
----------------------------------	----

<b>Fault Location Bridge Test Sets</b> . . . . .	40t
<b>Feeders and Straighteners, Aerial Cable</b> . . . . .	8p
<b>Fibre Conduit</b> . . . . .	6p
Test Boards (Linen) . . . . .	6p
<b>Figures, Aluminum, Embossed</b> . . . . .	11m
<b>Files, Mill</b> . . . . .	26t
<b>Fire Alarm Howlers</b> . . . . .	4w
Extinguishers . . . . .	6w
Extinguishing Liquid . . . . .	6w
Pots . . . . .	21p, 22p
<b>Fixtures, Extension, Side Pole</b> . . . . .	16m
<b>Flare, Big Beam</b> . . . . .	8w
<b>Flat Cross Arm Brace</b> . . . . .	17m
Lift Plates . . . . .	9m
<b>Flexible Pulling Grips</b> . . . . .	15p
<b>Folding Rules</b> . . . . .	33t
Take-Up Reels . . . . .	11t
Windshields . . . . .	22p
<b>Fork Bolts, Insulated</b> . . . . .	.7s
<b>Forks</b>	
Insulated . . . . .	.7s
Raising . . . . .	10t
<b>Forms, Blank</b> . . . . .	8w
<b>Frames, Distributing</b> . . . . .	14q, 15q
<b>Frames, Hack Saw</b> . . . . .	.5t
<b>Frames and Covers, Manhole</b> . . . . .	9p
<b>Framing Chisels, Socket</b> . . . . .	26t
<b>Friction Tape</b> . . . . .	16w, 17w
<b>Furnaces, Soldering</b> . . . . .	22p
<b>Fuse Wire, Blow-Rite</b> . . . . .	13q
<b>Fuses</b>	
Blow-Rite . . . . .	13q
Enclosed . . . . .	13q
Fibre . . . . .	13q, 14q
Heat Coil . . . . .	12q, 13q
Mica . . . . .	13q
Wood . . . . .	14q

**G**

<b>Gaff Protectors</b> . . . . .	22t
Sharpening Gage . . . . .	24t
<b>Gas Tanks, Prest-O-Lite</b> . . . . .	36t
<b>Generator Cable</b> . . . . .	5p
<b>Glass Insulators</b> . . . . .	3s, 4s
<b>Glove Bags, Linemen's</b> . . . . .	11w
<b>Gloves, Rubber Linemen's</b> . . . . .	11w
<b>Grade Clamps</b> . . . . .	8m

GENERAL INDEX—SUPPLIES DIVISION (Cont.)

Gray Label Dry Cells . . . . .	17q
Gray Pay Stations . . . . .	6u, 7u, 8u
Grinder, Bench . . . . .	34t
Grip-Flex Insulator Ties . . . . .	11s
<b>Grips</b>	
Buffalo . . . . .	16t
Cable . . . . .	15p, 16t
Chicago . . . . .	16t
Drop Wire . . . . .	12w
Haven's . . . . .	16t
Wire . . . . .	15p, 16t
Ground Clamps, Station . . . . .	6m
Rod Clamps . . . . .	5m, 6m
Rods . . . . .	6m
Tents . . . . .	13p
Wire . . . . .	6r
Guard Rails, Manhole . . . . .	9p
<b>Guards</b>	
Guy . . . . .	9m
Hub . . . . .	10m
Pike Pole . . . . .	10t
U-Cable . . . . .	15m
Gun, Solder . . . . .	10w
Guy Clamps . . . . .	7m
Clips . . . . .	12w
Guards . . . . .	9m
Hook Strain Plates . . . . .	9m
Hooks . . . . .	10m
Plates . . . . .	8m, 9m
Shims . . . . .	10m
Strand . . . . .	9r
Thimbles . . . . .	8m
Wire Clip Tools . . . . .	12w
Wire Clips . . . . .	12w
Wire Protectors . . . . .	9m

**H**

Habidure Wire . . . . .	6r
Habirshaw Wire . . . . .	3r, 4r, 5r, 6r
Hack Saw Blades . . . . .	5t
Frames . . . . .	5t
Hammer Drills . . . . .	35t
Drive Anchors . . . . .	17w
<b>Hammers</b>	
Ball Pein . . . . .	26t
Electric . . . . .	35t
Nail . . . . .	26t

Hand Drills . . . . .	30t, 31t
Lines . . . . .	17t
Saws . . . . .	5t
Tally Counters . . . . .	5w
<b>Handles</b>	
Auger, Telescope . . . . .	7t
Cant Hook . . . . .	9t
Carrying Hook . . . . .	9t
Digger . . . . .	7t
Lug Hook . . . . .	9t
Peavey . . . . .	9t
Pike Pole . . . . .	10t
Raising Fork . . . . .	10t
Shovel . . . . .	7t, 8t
Slick . . . . .	6t
Soldering Copper . . . . .	20p
Spoon . . . . .	8t
Tamping Bar . . . . .	6t
Tree Trimmer . . . . .	3t, 4t
<b>Hangers</b>	
Cable . . . . .	14p
Messenger . . . . .	11m
Hardwood Dressers . . . . .	18p
Hatchets, Broad . . . . .	27t
Haven's Grips . . . . .	16t
Heat Coil Fuses . . . . .	12q, 13q
Highway Crossover Brackets . . . . .	16m
<b>Hoists</b>	
Chain . . . . .	17t, 18t, 19t
Lever, Ratchet . . . . .	17t
<b>Holders</b>	
Drill . . . . .	27t
Soldering Iron . . . . .	9w, 10w
Wire . . . . .	7s, 8s
Hole Diggers, Post . . . . .	7t
Holgun Drill . . . . .	34t
Holsters, Tool . . . . .	12s
Hook Bolts, Crossover Bracket . . . . .	16m
Hook Type Strain Plates . . . . .	9m
<b>Hooks</b>	
Cable Rack, Underground . . . . .	10p
Cant . . . . .	9t
Carrying . . . . .	9t
Drive . . . . .	12w
Drop Wire . . . . .	13w
Guy . . . . .	10m
House and Pole . . . . .	13w

GENERAL INDEX—SUPPLIES DIVISION (Cont.)

Lug . . . . .	9t
Manhole Cover . . . . .	9p
Shave . . . . .	20p
Storm Guy . . . . .	10m
<b>House Brackets</b> . . . . .	19m
Hooks . . . . .	13w
<b>Howes Wire Tools</b> . . . . .	16t
<b>Howlers</b>	
Factory . . . . .	3w
Fire Alarm . . . . .	4w
Mine Type . . . . .	4w
Weatherproof . . . . .	3w, 4w
<b>Hub Guards</b> . . . . .	10m
<b>Hubeye Bolts</b> . . . . .	13m, 14m
Nuts . . . . .	14m
<b>Hubeyes</b> . . . . .	13m

**I**

<b>Identification Tags</b> . . . . .	17p
<b>Indoor Arresters</b> . . . . .	10q
<b>Inside Wiring Nails</b> . . . . .	15w
<b>Insulated Clevises</b> . . . . .	6s, 7s
Fork Bolts . . . . .	7s
Forks . . . . .	7s
Nails . . . . .	15w
Screw Eyes . . . . .	6s
Staples . . . . .	15w
Wire . . . . .	3r, 4r, 5r, 6r
<b>Insulating Sleeves, Lead</b> . . . . .	16p
Sleeves, Nicopress . . . . .	9s, 10s
Sleeves, Paper . . . . .	16p
Tape . . . . .	16w, 17w
<b>Insulator Ties</b> . . . . .	11s
<b>Insulators</b>	
Cable . . . . .	16p
Glass . . . . .	3s, 4s
Hook, Cable Rack, Underground . . . . .	10p
Non-Breakable . . . . .	5s
Porcelain . . . . .	5s
Split . . . . .	5s
<b>Inter-Comm Cable</b> . . . . .	4p
<b>Interior Junction Box</b> . . . . .	12q
Wire . . . . .	4r, 6r
<b>Iron Wood Screws</b> . . . . .	20w
<b>Irons</b>	
Pulling-In . . . . .	10p
Soldering . . . . .	9w, 10w

**J**

<b>Jacks</b>	
Cable Reel . . . . .	8p
Drum . . . . .	8p
Pole . . . . .	18t, 19t
Pushing and Pulling, Pipe . . . . .	19t
Ratchet . . . . .	18t, 19t
Reel . . . . .	8p
Screw . . . . .	8p
Tensioning, Cable and Wire . . . . .	18t
<b>Jenny Supports</b> . . . . .	10t
<b>Joint Rules</b> . . . . .	33t
Tape, Conduit . . . . .	6p
<b>Journals</b>	
Cash . . . . .	8w
Toll . . . . .	8w
<b>Junction Box</b> . . . . .	12q

**K**

<b>Kits, Tool</b> . . . . .	25t
<b>Kling Klamps</b> . . . . .	8m
<b>Knife Switches</b> . . . . .	16q
<b>Knives</b>	
Draw . . . . .	28t
Electrician's . . . . .	4t
Splitting, Cable Sheath . . . . .	20p
<b>Knob Racks, Distributing</b> . . . . .	7s
Screws . . . . .	6s
<b>Knobs</b>	
C.B. . . . .	6s
Drop Wire . . . . .	6s
Nail, Split . . . . .	6s
Porcelain . . . . .	5s, 7s
Self-Tying . . . . .	6s
<b>Korite Cable Compound</b> . . . . .	17p

**L**

<b>Lacing Twine</b> . . . . .	18p
<b>Ladder Shoes</b> . . . . .	12t
<b>Ladders</b>	
Extension . . . . .	12t
Manhole . . . . .	9p
Sectional . . . . .	12t
<b>Ladles, Pouring</b> . . . . .	18p
<b>Lag Bolts</b> . . . . .	12m
Screws . . . . .	12m
Screw Expansion Shields . . . . .	17w

GENERAL INDEX—SUPPLIES DIVISION (Cont.)

Lamps, Big Beam . . . . .	8w
Lashing Wire . . . . .	12p
Lead Covered Cable . . . . .	3p, 4p
Sleeves . . . . .	16p
and Rubber Covered Wire . . . . .	7r
Leather Protectors, Lineman's Glove . . . . .	11w
Ledgers	
General . . . . .	8w
Rental and Tool, Subscribers' . . . . .	8w
Toll . . . . .	8w
Letters, Aluminum, Embossed . . . . .	11m
Lever Hoists, Ratchet . . . . .	17t
Lift Plates . . . . .	9m, 10m
Lightning Arresters . . . . .	8q, 10q
Line Wire . . . . .	7r, 8r
Linen Tapes . . . . .	33t
Linemen's Belts . . . . .	21t, 22t, 23t
Outfits, Prest-O-Lite . . . . .	36t
Safety Cable Chairs . . . . .	10p
Safety Straps . . . . .	23t
Tools, Chicago . . . . .	16t
Wrenches . . . . .	15t
Linen Test Boards . . . . .	6p
Lines, Hand . . . . .	17t
Links, Reinforcing . . . . .	10m
Liquid	
Fire Extinguishing . . . . .	6w
Soldering . . . . .	19p
Load Binders . . . . .	18t
Plates . . . . .	9m
Loud Ringing Bells . . . . .	6w
Luffing Grips . . . . .	15p
Lug Hook Handles . . . . .	9t
Hooks . . . . .	9t

**M**

Machine Bolts . . . . .	12m
Main Distributing Frames . . . . .	15q
Manhole Cover Hooks . . . . .	9p
Frames and Covers . . . . .	9p
Guard Rails . . . . .	9p
Ladders . . . . .	9p
Warning Signs . . . . .	10p
Marline Cable Hangers . . . . .	14p
Twine . . . . .	12p
Masonry Drill . . . . .	28t
Measuring Tapes . . . . .	33t

Melting Pots . . . . .	18p
Message Timers . . . . .	7w
Messenger Hangers . . . . .	11m
Strand . . . . .	9r
Metal Pouring Ladle . . . . .	18p
Metal Rim Tags . . . . .	17p
Meters	
Detecto . . . . .	37t, 38t, 39t
Pocket . . . . .	37t
Service, Telephone . . . . .	40t
Mica Fuses . . . . .	13q
Michigan Tapes, Chain . . . . .	33t
Mill Files . . . . .	26t
Milonite Nails . . . . .	15w
Mine Type Howlers . . . . .	4w
Moulding Strain Plates . . . . .	8m
Mounting Straps, U-Cable . . . . .	15m
Sub-Station Protector . . . . .	7q
Mule Supports . . . . .	10t
Muslin Tape . . . . .	18p

**N**

Nail Hammers . . . . .	26t
Knobs, Split . . . . .	6s
Nails	
Common . . . . .	19w
Dating, Pole . . . . .	11m
Insulated . . . . .	15w
Wiring . . . . .	15w
Neoprene Wire . . . . .	5r
Never-Creep Plates, Anchor . . . . .	3m
Rods, Anchor . . . . .	4m
Nicopress Dead-Ends . . . . .	11s
Sleeves . . . . .	9s, 10s
Tools . . . . .	12s
Tool Holsters . . . . .	12s
Nicotap Sleeves . . . . .	10s
Non-Metallic Buckets, Collapsible . . . . .	25t
Nuts	
Eye . . . . .	14m
Hub Eye . . . . .	14m
Off-Set Dead-Ends . . . . .	11s
Ohmmeters . . . . .	38t, 39t
Operator' Chairs, Posture . . . . .	3u, 4u
Outdoor Arresters . . . . .	8q

**O**

GENERAL INDEX—SUPPLIES DIVISION (Cont.)

Outfits, Linemen's, Prest-O-Lite . . . . . 36t  
 Outside Distributing Wire . . . . . 3r, 4r, 5r

**P**

**Pads, Climber** . . . . . 20t

**Pails**

Canvas . . . . . 25t  
 Non-Metallic, Collapsible . . . . . 25t

**Paper Sleeves** . . . . . 16p

**Paraffin** . . . . . 16p

**Paragon Battery Boxes** . . . . . 16q

**Paste**

Burnishing . . . . . 17p  
 Soldering . . . . . 19p

**Pasters, Cable** . . . . . 20p

**Pay Station Accessories** . . . . . 8u, 9u

Signs . . . . . 6u

**Pay Stations** . . . . . 6u, 7u, 8u

**Pay-Out Reels** . . . . . 11t

**Peavey Handles** . . . . . 9t

**Peavies** . . . . . 8t

**Pedestals, Calculagraph** . . . . . 7w

**Pee-Wee Clips** . . . . . 15w

**Perfection Nails** . . . . . 15w

**Phillips Screwdrivers** . . . . . 30t, 32t

Screwdriver Bits . . . . . 33t

**Pike Pole Guards** . . . . . 10t

Pole Handles . . . . . 9t, 10t

Poles . . . . . 9t, 10t

**Pins**

Corner . . . . . 6n

Dowel . . . . . 6p

Escutcheon . . . . . 11m

Transposition . . . . . 6n

Turn . . . . . 20p

Western Union . . . . . 20m

Wood . . . . . 5n, 6n

Wood Top . . . . . 20m

**Pipe Pushing and Pulling Jacks** . . . . . 18t

**Pipe, Reinforcing** . . . . . 15m

**Plates**

Anchor . . . . . 3m

Guy . . . . . 10m

Lift . . . . . 9m, 10m

Load . . . . . 9m

Strain . . . . . 8m, 9m

**Plier Pockets** . . . . . 22t

**Pliers** . . . . . 13t, 14t, 15t

**Plug Burnishing Paste** . . . . . 17p

**Plugs, Drift** . . . . . 20p

**Plumbers' Candles** . . . . . 16p

**Pocket Meters** . . . . . 37t

**Pockets, Plier** . . . . . 22t, 23t, 24t

**Point Type Transposition Brackets** . . . . . 18m

**Points and Chucks, Drill** . . . . . 31t

**Pole Balconies** . . . . . 20m

Bits . . . . . 28t

Brackets . . . . . 18m, 19m

Dating Nails . . . . . 11m

Hooks . . . . . 13w

Jacks . . . . . 18t, 19t

Letters . . . . . 11m

Pushers . . . . . 18t

Reinforcing Material . . . . . 15m

Seats . . . . . 20m

Sights (Bisectors) . . . . . 35t

Steps . . . . . 16m, 6n

**Poles**

Cedar . . . . . 3n, 4n

Pike . . . . . 9t, 10t

Pine . . . . . 3n, 4n

**Pony Arms** . . . . . 5n

**Porcelain Insulators** . . . . . 5s

Knobs . . . . . 5s, 7s

Tubes . . . . . 6s

Wire Holders . . . . . 7s, 8s

**Post Hole Digger Handles** . . . . . 7t

Diggers . . . . . 7t

**Posture Chairs, Operator's** . . . . . 3u, 4u

**Pots**

Fire . . . . . 21p, 22p

Melting . . . . . 18p

Solder . . . . . 18p

**Pouring Ladles** . . . . . 18p

**Preserver, Wood** . . . . . 6n

**Prest-O-Lite Outfits** . . . . . 36t

Linemen's Outfits . . . . . 36t

Tanks, Gas . . . . . 36t

**Protector Units, Transmount** . . . . . 6q

**Protectors**

Central Office . . . . . 15q, 16q

Guy Wire (Shields) . . . . . 9m

Leather, Linemen's Glove . . . . . 11w

Station . . . . . 7q, 9q, 10q

Sub-Station . . . . . 7q

GENERAL INDEX—SUPPLIES DIVISION (Cont.)

Protek-Sorb Desiccant . . . . . 18p  
 Pruners . . . . . 3t, 4t, 5t  
 Pruning Saws . . . . . 3t, 5t  
**Pullers**  
   Pole . . . . . 18t, 19t  
   Slack . . . . . 11p, 17t, 18t  
**Pulley Blocks** . . . . . 19t  
**Pulling and Pushing Jacks, Pipe** . . . . . 18t, 19t  
**Pulling Grips, Wire** . . . . . 15p  
**Pulling-In Irons** . . . . . 10p  
**Pushers, Pole** . . . . . 18t, 19t  
**Pushing and Pulling Jacks, Pipe** . . . . . 18t, 19t  
**Pyramid Cone Anchors** . . . . . 3m  
**Pyrene Extinguishers, Fire** . . . . . 6w  
   Liquid, Fire Extinguishing . . . . . 6w

**R**

**Rack Insulators, Cable** . . . . . 10p  
**Racks**  
   Cable, Underground . . . . . 10p  
   Knob, Distributing . . . . . 7s  
   Telephone, Knobs . . . . . 7s  
**Radio Drills** . . . . . 31t  
**Rails, Guard, Manhole** . . . . . 9p  
**Raising Fork Handles** . . . . . 10t  
   Forks . . . . . 10t  
**Rare Gas Relays (Tubes)** . . . . . 9w  
**Ratchet Bit Braces** . . . . . 32t  
   Hand Drills . . . . . 31t  
   Jacks . . . . . 19t  
   Lever Hoists . . . . . 17t  
   Screwdrivers . . . . . 30t, 31t, 32t  
   Tap Wrenches . . . . . 30t  
**Receptacles, Coin, Pay Station** . . . . . 9u  
**Rectifiers (Battery Eliminators)** . . . . . 21w  
**Record Blanks** . . . . . 8w  
**Reducing Sleeves, Nicopress** . . . . . 10s  
**Reel Jacks** . . . . . 8p  
   Wire . . . . . 12t  
**Reels**  
   Barrow . . . . . 11t  
   Pay-Out . . . . . 11t  
   Pay-Out and Take-Up . . . . . 11t  
**Reinforcing Bands** . . . . . 15m  
   Castings . . . . . 15m  
   Links . . . . . 10m  
   Material, Pole . . . . . 15m

Pipe . . . . . 15m  
**Reinforcing and Safety Straps** . . . . . 10m  
**Relays**  
   Rare Gas . . . . . 9w  
   Telecode . . . . . 4w, 5w  
**Rental and Toll Ledgers** . . . . . 8w  
**Repair Sleeves** . . . . . 10s  
**Repeaters, Voice** . . . . . 5v  
**Repeating Coils and Housing** . . . . . 14q  
**Retractable Cords** . . . . . 11w  
**Ribbon, Bonding** . . . . . 17p  
**Ribbons, Calculagraph** . . . . . 7w  
**Ringing Tool** . . . . . 11p  
**Rings**  
   Bridle . . . . . 17w  
   Cable . . . . . 13p  
   Drive . . . . . 17w  
**Rods**  
   Anchor, Ball Point . . . . . 4m  
   Anchor, Threaded . . . . . 4m  
   Ground . . . . . 6m  
   Ground Clamps . . . . . 5m, 6m  
**Roll-A-Reel** . . . . . 6p  
**Rollers, Cable** . . . . . 11p  
**Rope Clips, Wire** . . . . . 7m  
   Thimbles, Wire . . . . . 8m  
**Rosin Core Solder** . . . . . 19p  
**Round Washers** . . . . . 11m  
**Rubber Clothing** . . . . . 11w  
   Glove Bags, Linemen's . . . . . 11w  
   Gloves, Linemen's . . . . . 11w  
   Insulated Wire . . . . . 3r, 4r, 6r, 7r  
   Tape . . . . . 16w  
**Rules**  
   Boxwood . . . . . 33t  
   Folding . . . . . 33t  
   Spring Joint . . . . . 33t

**S**

**Saddles**  
   Cable Ring . . . . . 13p  
   Pole Reinforcing . . . . . 15m  
**Safety Belts** . . . . . 21t, 22t, 23t  
   Cable Cars, Linemen's . . . . . 10p  
   Shields . . . . . 22p  
   Straps, Linemen's . . . . . 23t, 24t  
   Straps, Reinforcing . . . . . 10m

GENERAL INDEX—SUPPLIES DIVISION (Cont.)

<b>Salts, Soldering</b> . . . . .	19p
<b>Saw Blades, Hack</b> . . . . .	5t
<b>Frames, Hack</b> . . . . .	5t
<b>Saws</b>	
<b>Cable</b> . . . . .	5t
<b>Pruning</b> . . . . .	3t, 5t
<b>Tree Trimmer</b> . . . . .	3t, 5t
<b>Sawtooth Discharge Blocks</b> . . . . .	8q
<b>Scissors, Electricians'</b> . . . . .	15t
<b>Scotch Tape</b> . . . . .	16w
<b>Screw Anchors</b> . . . . .	18w
<b>Eyes, Insulated</b> . . . . .	.6s
<b>Jacks</b> . . . . .	8p
<b>Screwdriver Bits</b> . . . . .	32t, 33t
<b>Screwdrivers</b>	
<b>Plain</b> . . . . .	29t
<b>Phillips</b> . . . . .	30t
<b>Ratchet</b> . . . . .	30t
<b>Ratchet, Offset</b> . . . . .	31t, 32t
<b>Screws</b>	
<b>Angle</b> . . . . .	.6s
<b>Knob</b> . . . . .	.6s
<b>Lag</b> . . . . .	12m
<b>Wood</b> . . . . .	20w
<b>Seats</b>	
<b>Chair</b> . . . . .	4u
<b>Pole</b> . . . . .	20m
<b>Sectional Ladders</b> . . . . .	12t
<b>Self-Tying Knobs</b> . . . . .	.6s
<b>Service Connectors</b> . . . . .	13w
<b>Meters</b> . . . . .	40t
<b>Wire Holders</b> . . . . .	.8s
<b>Servisleeves</b> . . . . .	8m
<b>Sharpening Gage, Gaff</b> . . . . .	24t
<b>Shave Hooks</b> . . . . .	20p
<b>Shelf Brackets, Pay Station</b> . . . . .	9u
<b>Shields</b>	
<b>Cable Duct</b> . . . . .	10p
<b>Expansion</b> . . . . .	17w
<b>Guy</b> . . . . .	9m
<b>Wind, Folding</b> . . . . .	22p
<b>Shims, Guy</b> . . . . .	10m
<b>Ship Auger Car Bits</b> . . . . .	29t
<b>Shoes, Ladder</b> . . . . .	12t
<b>Shovel Handles</b> . . . . .	7t, 8t
<b>Shovels</b> . . . . .	7t, 8t
<b>Side Extension Fixtures, Pole</b> . . . . .	16m

<b>Signal Pins</b> . . . . .	20w
<b>Transmitter, Pay Station</b> . . . . .	9u
<b>Signals</b>	
<b>Factory</b> . . . . .	3w, 4w
<b>Fire Alarm</b> . . . . .	4w
<b>Signs</b>	
<b>Pay Station</b> . . . . .	6u
<b>Warning, Manhole</b> . . . . .	10p
<b>Slack Pullers</b> . . . . .	11p, 17t, 18t
<b>Sleeve and Wire Clamps</b> . . . . .	15t
<b>Sleeves</b>	
<b>Cotton</b> . . . . .	16p
<b>Insulating</b> . . . . .	16p
<b>Lead</b> . . . . .	16p
<b>Nicopress</b> . . . . .	.9s, 10s
<b>Paper</b> . . . . .	16p
<b>Reducing</b> . . . . .	10s
<b>Repair</b> . . . . .	10s
<b>Splicing</b> . . . . .	.9s
<b>Sleeving, Cotton</b> . . . . .	16g, 16p
<b>Slick Handles</b> . . . . .	.6t
<b>Slitter, Cable</b> . . . . .	11p
<b>Socket Wrench</b> . . . . .	4q, 15t, 27t
<b>Solder</b>	
<b>Acid Core</b> . . . . .	19p
<b>Bar</b> . . . . .	19p
<b>Rosin Core</b> . . . . .	19p
<b>Wiping</b> . . . . .	19p
<b>Wire</b> . . . . .	19p
<b>Solder Guns</b> . . . . .	10w
<b>Pots</b> . . . . .	18p
<b>Pouring Ladle</b> . . . . .	18p
<b>Soldering Copper Handles</b> . . . . .	20p
<b>Coppers</b> . . . . .	20p, 9w, 10w
<b>Furnaces</b> . . . . .	20p, 21p, 22p
<b>Iron Stands</b> . . . . .	10w
<b>Iron Tips</b> . . . . .	9w, 10w
<b>Irons</b> . . . . .	9w, 10w
<b>Liquid</b> . . . . .	19p
<b>Paste</b> . . . . .	19p
<b>Salts</b> . . . . .	19p
<b>Span Clamps</b> . . . . .	7m
<b>Spikes</b> . . . . .	19w
<b>Spinners, Cable</b> . . . . .	11p, 12p
<b>Spinning Wire</b> . . . . .	12p
<b>Spintite Socket Wrenches</b> . . . . .	27t
<b>Splicing Clamps</b> . . . . .	15t

GENERAL INDEX—SUPPLIES DIVISION (Cont.)

Sleeves . . . . .	8s, 9s
Split Grips . . . . .	15p
Insulators, Porcelain . . . . .	.5s
Nail Knobs . . . . .	.6s
Splitting Knives, Cable Sheath . . . . .	20p
Spoon Handles . . . . .	.8t
Spoons . . . . .	.8t
Spring Joint Rules . . . . .	33t
Springin Toggle Bolts . . . . .	19w
Spuds, Digging . . . . .	.6t
Square Washers . . . . .	11m
Stands, Soldering Iron . . . . .	10w
Staple Drivers . . . . .	6w
Staples, Insulated . . . . .	15w
Star Drills . . . . .	28t
Station Ground Clamps . . . . .	6m
Protectors . . . . .	7q, 9q, 10q
Stations, Pay . . . . .	6u, 7u, 8u
Stazrite Guy Guards . . . . .	9m
Stearine Candles . . . . .	16p
Steel Cable Lashing Wire . . . . .	12p
Clamps . . . . .	14p, 15p
Steelwing Anchors . . . . .	5m
Steps, Pole . . . . .	16m, 6n
Storm Guy Hooks . . . . .	10m
Straighteners and Feeders Aerial Cable . . . . .	8p
Strain Insulators, Porcelain . . . . .	.5s
Plates . . . . .	8m, 9m
Strand	
Guy . . . . .	.9r
Messenger . . . . .	.9r
Strand Connectors . . . . .	18w
Straps	
Bracket . . . . .	6n
Cable . . . . .	14p
Climber . . . . .	20t
Conduit . . . . .	14p
Mounting, U-Cable . . . . .	15m
Reinforcing and Safety . . . . .	10m
Safety, Linemen's . . . . .	23t, 24t
Strippers, Braid . . . . .	15t
Stripping Knives . . . . .	20p
Strips, Terminal . . . . .	11q
Stubbing Washers . . . . .	11m
Stuffing Boxes, Cable Terminal . . . . .	5q
Sturgis Chairs, Posture . . . . .	3u, 4u
Subscribers' Bills . . . . .	8w

Sub-Station Protectors . . . . .	10q
Supervisors' Chairs . . . . .	4u
Supports	
Belt . . . . .	23t
Cable . . . . .	14p
Jenny . . . . .	10t
Mule . . . . .	10t
Suspension Clamps, Cable . . . . .	8m, 19m
Switchboard Cable . . . . .	5p, 6p
Wire . . . . .	6p
Switches, Knife . . . . .	16q

T

Tackle Blocks . . . . .	17t
Tags, Metal Rim . . . . .	17p
Take-Up Reels . . . . .	11t
Tally Counters . . . . .	5w
Tamping Bar Handles . . . . .	.6t
Bars . . . . .	6t, 7t
Tandem Transposition Brackets . . . . .	18m
Tanks, Gas, Prest-O-Lite . . . . .	36t
Tap Wrenches . . . . .	30t
Tape	
Chain . . . . .	33t
Friction . . . . .	16w, 17w
Insulating . . . . .	16w, 17w
Joint, Conduit . . . . .	6p
Linen . . . . .	33t
Muslin . . . . .	18p
Measuring . . . . .	33t
Okoprene . . . . .	16w
Rubber . . . . .	16w
Scotch . . . . .	16w
Steel . . . . .	33t
Telecode Relays . . . . .	4w, 5w
Telefaults, Woodpecker . . . . .	39t
Teleheights . . . . .	39t
Telephone Booths . . . . .	5u, 6u
Bracket Bolts . . . . .	12m
Distributing Brackets . . . . .	14m
Poles . . . . .	3n, 4n
Station Protectors . . . . .	7q, 9q, 10q
Wire . . . . .	Section r
Telescope Auger Handles . . . . .	7t
Telohm . . . . .	39t
Temperometers . . . . .	17p
Tensioning Jacks, Cable and Wire . . . . .	18t

GENERAL INDEX—SUPPLIES DIVISION (Cont.)

**Tents**

Cable Splicers' Aerial . . . . . 13p  
 Ground . . . . . 13p  
**Terminal Boxes, Building** . . . . . 11q  
 Strips . . . . . 11q

**Terminals**

Building . . . . . 12q  
 Buried Wire . . . . . 9q  
 Cable . . . . . 3q, 4q, 5q, 6q, 13q

**Test Boards, Linen**

Clips . . . . . 14w, 15w  
 Equipment, Transmission . . . . . 41t  
 Sets . . . . . 37t, 38t, 39t, 40t, 41t

**Testerm Drop Wire Connector**

. . . . . 9q

**Testers**

Cable . . . . . 38t  
 Current Flow . . . . . 41t  
 Transmission . . . . . 41t

**Thermometers, Cablemen's**

. . . . . 17p

**Thimbles, Guy**

. . . . . 8m

**Wire Rope**

. . . . . 8m

**Thimbleye Rods**

. . . . . 4m

**Ties, Insulator**

. . . . . 11s

**Through Bolts**

. . . . . 12m

**Tickets**

Toll . . . . . 8w  
 Trouble . . . . . 8w

**Tie Wire**

. . . . . 7r

**Timers, Message**

. . . . . 7w

**Tips, Sodering Iron**

. . . . . 9w, 10w

**Toggle Bolts**

. . . . . 18w, 19w

**Toll Bills**

. . . . . 8w

**Cable**

. . . . . 5p

**Tickets**

. . . . . 8w

**Tool Bags**

. . . . . 24t, 25t

**Belts**

. . . . . 21t, 22t, 23t

**Cases, Hip Pocket**

. . . . . 23t

**Holsters**

. . . . . 12s

**Kits**

. . . . . 25t

**Pockets**

. . . . . 22t, 24t

**Pouches**

. . . . . 24t

**Tools**

Digging . . . . . 6t, 7t

Guy Wire Clip . . . . . 12w

Linemen's, Chicago . . . . . 16t

Nicopress . . . . . 12s

Slick . . . . . 6t

Wire, Howes . . . . . 16t

**Torches, Blow** . . . . . 20p, 21p, 22p

**Transmission Test Sets** . . . . . 41t

**Transmount Protector Units** . . . . . 6q

**Transposition Brackets** . . . . . 18m, 19m, 6n

Pins . . . . . 6n

**Tree Pruners** . . . . . 3t, 4t

Trimmer Handles . . . . . 3t, 4t

Trimmer Saws . . . . . 3t, 4t, 5t

**Trimmers, Tree** . . . . . 3t, 4t, 5t

**Trip Augers** . . . . . 7t

**Trouble Tickets** . . . . . 8w

**Tru-Gap Dischargers** . . . . . 11q

**Tubes**

Porcelain . . . . . 6s

Rare Gas Relay . . . . . 9w

**Tubular Pike Pole Guards** . . . . . 10t

**Turn Pins** . . . . . 20p

**Twine**

Lacing . . . . . 18p

Marline . . . . . 12p

**Twist Drills** . . . . . 27t

**U**

**U-Cable Guards** . . . . . 15m

Mounting Straps . . . . . 15m

**Underground Cable Rack Hook Insulators** . . . . . 10p

Cable Rack Hooks . . . . . 10p

Cable Racks . . . . . 10p

Cable Terminals . . . . . 5q, 6q, 9q

**Universal Messenger Hangers** . . . . . 11m

**Utility Electric Drills** . . . . . 35t

**V**

**Vacuum Cleaners** . . . . . 5w

**Vertical Braces** . . . . . 16m, 17m

**Victor Insulators, Split Porcelain** . . . . . 5s

**Vincent Relays, Rare Gas** . . . . . 9w

**Vise Clips** . . . . . 7m

**Vises** . . . . . 32t

**Voice Repeaters** . . . . . 5v

**Voltammeters** . . . . . 37t, 38t

**Voltmeters** . . . . . 37t, 38t

**Volt-Ohmmeters** . . . . . 38t, 39t

**W**

**Wall Distributing Frames** . . . . . 14q

**Warning Signs, Manhole** . . . . . 10p

GENERAL INDEX—SUPPLIES DIVISION (Cont.)

**Washers**

Clip, Bracket . . . . .	6n
Curved . . . . .	11m
Half Oval . . . . .	15m
Round . . . . .	11m
Square . . . . .	11m
Stubbing . . . . .	11m

**Wax, Yellow** . . . . . 16p

**Weatherproof Howlers** . . . . . 3w, 4w

**Weather Resistant Tape** . . . . . 16w

**Wedge-Tite Clamps** . . . . . 14w

**Western Union Pins** . . . . . 20m

**Wheatstone Bridges** . . . . . 40t

**Wickless Candles** . . . . . 16p

**Windshields, Folding** . . . . . 22p

**Wiping Cloths** . . . . . 18p

Solder . . . . . 19p

**Wire**

Bridle . . . . . 4r, 6r

Construction . . . . . 7r

Distributing, Outside . . . . . 3r, 4r, 5r, 6r

Drop . . . . . 6s

Fuse, Blow-Rite . . . . . 13q

Galvanized Iron . . . . . 7r, 8r

Ground . . . . . 6r

Interior . . . . . 4r, 6r

Lashing . . . . . 12p

Line . . . . . 7r, 8r

Neoprene . . . . . 5r

Rubber Insulated . . . . . 3r, 4r, 6r

Rubber Insulated, Lead Covered . . . . . 7r

Spinning . . . . . 12p

Switchboard . . . . . 6p

Tie . . . . . 7r

**Wire Clamps** . . . . . 14p, 15t

Clips, Guy . . . . . 12w

Grips . . . . . 15p

Holdes . . . . . 7s, 8s

Reel . . . . . 12t

Rope Clips . . . . . 7m

Rope Thimbles . . . . . 8m

Solder . . . . . 19p

Tools, Howes . . . . . 16t

**Wire and Cable Tensioning Jacks** . . . . . 18t

**Wire and Sleeve Clamps** . . . . . 15t

**Wiring Nails** . . . . . 15w

**Wood Boring Brace Drills** . . . . . 28t

Brackets . . . . . 5n

Conduit, Creosoted . . . . . 7p

Pins . . . . . 5n, 6n

Pole Steps . . . . . 6n

Preserver . . . . . 6n

Screws . . . . . 20w

Top Pins . . . . . 20w

Transposition Pins . . . . . 6n

**Woodpecker Telefaults** . . . . . 39t

**Wrenches**

Linemen's . . . . . 15t

Socket . . . . . 4q, 15t, 27t

Tap . . . . . 30t

**X**

**Xela Knives, Electricians'** . . . . . 4t

Scissors, Electricians' . . . . . 15t

**Y**

**Yankee Tools** . . . . . 29t, 30t, 31t, 32t

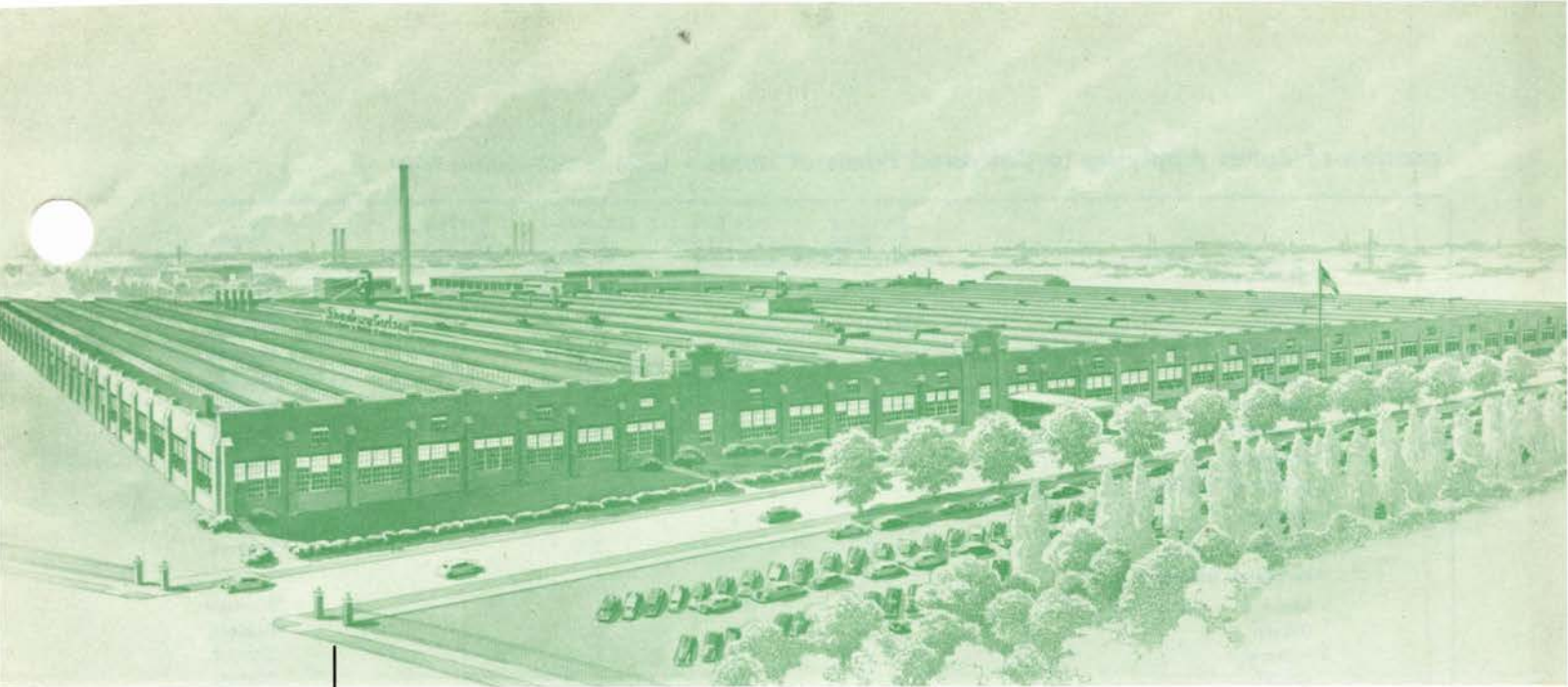

## **STROMBERG-CARLSON**

---

**POLE LINE MATERIALS**

---

**PROTECTION EQUIPMENT**

---

**CABLE, WIRE, INSULATORS**

---

**TOOLS, CHAIRS, BOOTHS**

---

**CARRIER SYSTEMS AND PARTS**

**STROMBERG-CARLSON COMPANY**

100 CARLSON ROAD • ROCHESTER 3, N. Y. • TEL. CULVER 0260

Location of Zones Applying to Delivered Prices of Items • Listed on the Following Pages

	Standard Porcelain Telephone Knobs	Pole Line Hardware and Specialties	Construc- tion Tools	Rubber Covered Telephone Wires	Anchors, Augers and Parts
Alabama	2	2	3	5	Eastern
*Alaska				7	Western
Arizona	4		4	7	Western
Arkansas	2	2	2	6	Eastern
California			4	7	Western
Colorado	***4	3	3	7	Western
Connecticut	1	1	2	1	Eastern
Delaware	1	1	2	2	Eastern
District of Columbia	1	1		2	Eastern
Florida	2	2	4	6	Eastern
Georgia	2	2	3	5	Eastern
*Hawaiian Islands				7	
Idaho	4	*4	4	7	Western
Illinois	1	1	1	4	Eastern
Indiana	1	1	1	3	Eastern
Iowa	1	1	1	5	Eastern
Kansas	††3	†3	2	6	Eastern
Kentucky	1	1	1	4	Eastern
Louisiana	2	2	3	6	Eastern
Maine	1	1	2	2	Eastern
Maryland	1	1	2	2	Eastern
Massachusetts	1	1	2	1	Eastern
Michigan	1	1	1	3	Eastern
Minnesota	1	1	1	5	Eastern
Mississippi	2	2	3	6	Eastern
Missouri	1	1	1	5	Eastern
Montana	4	‡3	4	7	Western
Nebraska	‡‡3	**3	2	6	Eastern
Nevada	4	§4	4	7	Western
New Hampshire	1	1	2	2	Eastern
New Jersey	1	1	2	1	Eastern
New Mexico	4	3	4	7	Western
New York	1	1	2	1	Eastern
North Carolina	2	2	3	4	Eastern
North Dakota	§§3	3	2	6	Eastern
Ohio	1	1	1	3	Eastern
Oklahoma	3	3	3	6	Eastern
Oregon			4	7	Western
*Panama Canal Zone				7	
Pennsylvania	1	1	2	1	Eastern
*Puerto Rico				7	
Rhode Island	1	1	2	1	Eastern
South Carolina	2	2	3	5	Eastern
South Dakota	****3	3	2	6	Eastern
Tennessee	2	2	2	5	Eastern
Texas	¶¶3	¶3	3	6	Eastern
Utah	4	4	4	7	Western
Vermont	1	1	2	2	Eastern
Virginia	1	1	2	2	Eastern
Washington			4	7	Western
West Virginia	1	1	1	3	Eastern
Wisconsin	1	1	1	4	Eastern
Wyoming		3	3	7	Western

\*Except Counties of Boundary, Bonner, Kootenai, Benewah, Shoshone, Latah, Clearwater, Nez Perce, Lewis and Idaho.

†Kansas City is in zone 1.

‡Texarkana is in zone 2.

\*For U. S. Possessions delivery, quote F.O.B. Steamer Dock at point of embarkation, freight allowed to destination.

‡Except Northern half of Lake County and the Counties of Flathead and Lincoln.

§Counties of Elko, Eureka, White Pine and Lincoln only.

\*\*Omaha is in zone 1.

\*\*\*Denver and Pueblo are in zone 3.

††Kansas City is in zone 1.

‡‡Lincoln and Omaha are in zone 1.

¶¶El Paso is in zone 4.

§§ Fargo is in zone 1.

\*\*\*\*Sioux Falls is in zone 1.

**STROMBERG-CARLSON**

# Pole Line Hardware



**All the necessary items for good pole line construction and maintenance: anchors, clamps, brackets, plates, bolts, washers.**

CONTENTS  
SECTION M

**POLE LINE HARDWARE**

---

	Page
Anchors and Rods .....	3m
Ground Rods and Clamps .....	5m
Cross Over Clamps .....	6m
Guy Clamps .....	7m
Wire or Strand Clips .....	7m
Span Clamps .....	7m
Servisleeves .....	8m
Grade Clamps .....	8m
Strain Plates .....	8m
Guy Guards .....	9m
Guy Hooks .....	10m
Messenger Hangers .....	11m
Pole Dating Figures .....	11m
Washers .....	11m
Screws, Bolts, Nuts, and Eyes .....	12m
Distributing and Corner Brackets .....	14m
Pole Reinforcing Material .....	15m
U-Cable Guards .....	15m
Pole Steps and Braces .....	16m
Transposition Brackets .....	18m
Corner Cable Clamps .....	19m
Signal Pins .....	20m
Pole Seats .....	20m

---

**ANCHORS AND RODS**

**EVERSTICK EXPANDING ANCHORS**

**Less Rods**

Ease of installation, ease of expansion, maximum power and long life are the result of years of experience and improvements in these anchors.

The exclusive Everstick guides hold the plates in perfect alignment during expansion of the anchor.



3-Way—Expanded

Anchors are made of certified malleable iron.

**2-Way Anchors**

Cat. No.	Stock No.	Anchor and Size Hole		Area Expan- ded	Anchor Wt. Lb.	Holding Power —Pounds—	
		In.	In.			Sq. In.	Sand
62	(890002)	6	5/8	55	7	3000	7000
82	(890003)	8	3/4	100	11	6000	16000

**3-Way Anchors**

633	(890004)	6	5/8	65	7 1/2	5000	11000
834	(890005)	8	5/8	90	11	6000	14000
836	(890006)	8	3/4	110	14	8000	18000
8310	(890007)	8	3/4	125	15	12000	24000
8312	(890008)	8	1	125	16	12000	24000
10316	(890009)	10	1	175	29	18000	45000

**4-Way Anchors**

64	(890010)	6	5/8	70	10	5000	12000
84-3/4	(890011)	8	3/4	125	16 1/2	12000	24000
84-1	(890012)	8	1	132	16 1/2	12000	24000
104	(890013)	10	1	210	30 1/2	20000	50000
124	(890014)	12	1 1/4	310	55	30000	70000

**HUB-ANCHORS**

**The Hubbard Expanding Anchor**

(Patent Applied For)

For all around strength, ease of installation and compactness, the Hub-Anchor is unsurpassed among anchors of the expanding type. The fluted plates which expand into the soil equally, are made extremely rigid by the straight, parallel grooves which are pressed into them. Protective coating is of the finest, corrosion resistant black paint.



For ease of handling while being transported and installed, a fine gauge, soft iron wire holds the plates in a closed position. When the anchor has been properly placed and the first expansion blow struck, the soft wire is sheared and the Hub-Anchor is free to expand.

Standard Hubeye and Tu-Hubeye Anchor Rods are used with Hub-Anchors.

Cat. No.	Stock No.	Description	Area Sq. In. Exp.	Anchor Rod Size	Approx. Ship. Wt.	
					In.	Lb. per 100
26050	(894656)	2 way—6 inch	53	1/2—5/8	485	
28090	(894657)	2 way—8 inch	94	5/8—3/4	965	
48100	(894658)	4 way—8 inch	112	5/8—3/4	1350	
48120	(894659)	4 way—8 inch	125	5/8—3/4	1400	
48135	(894660)	4 way—8 inch	135	5/8—3/4	1500	

**CHANCE PYRAMID CONE ANCHORS**

Their flat opposing faces increase the action of the wedging portion by elimination of rotation. The action is just the same as a flat wedge and equally effective.

The nut retaining feature not only securely retains the nut in event it is desired to reclaim the rod any time after installation, but locks the anchor on the rod and aids installation by making it possible to force the anchor down into the hole.



Cat. No.	Stock No.	Size	Rod Diam.	Rod Lgth.	Approx. Wt./C
6	(890015)	6"	1/2", 5/8"	6'	326
8	(890016)	8"	5/8", 3/4"	7'	654
10	(890017)	10"	5/8", 3/4"	7'	955
12	(890018)	12"	5/8", 3/4"	8'	1742
16	(890019)	16"	3/4", 1"	9'	3158
19	(890020)	19"	1", 1 1/4"	10'	5530
23	(890021)	23"	1", 1 1/4"	10'	7408

**CHANCE NEVER-CREEP ANCHORS**

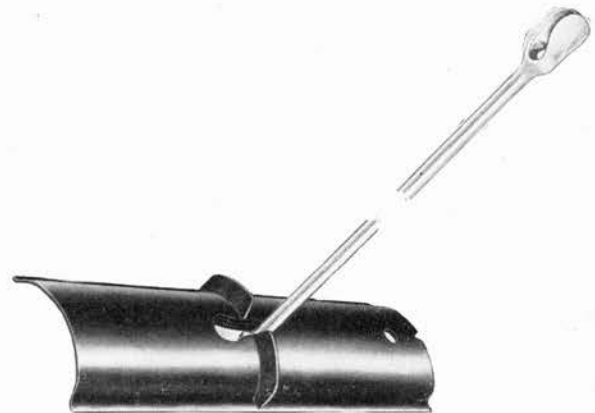

Never-Creep Anchors are efficient anchors for normal guying conditions because they pull entirely against solid, undisturbed earth. They are not dependent upon tamping of filled in earth and are not subject to serious loss of holding power due to seepage of moisture into the filled in hole.

Never-Creep Anchors are installed in five easy steps. Bore the hole at or near a 45 degree angle in the direction of the pole to be guyed. Drive the rod at right angles into the hole and in line with the hole and the pole. Hang the Never-Creep on the ball point of the rod using the Never-Creep installing bar, which fits the hole and notch provided on the end of the plate, then pull up the guy until strand is taut.

Cat. No.	Stock No.	Size	Rod Diam.	Rod Lgth.	Approx. Wt./C
617	(890023)	6"x17"	5/8"	7'	829
622	(890025)	6"x22"	3/4"	8'	1180
822	(890026)	8"x22"	3/4"	8'	1603
827	(890027)	8"x27"	3/4"	9'	1935
835	(890029)	8"x35"	1"	9'	2870
1040	(890030)	10"x40"	1"	10'	4525

## CHANCE THIMBLEYE ANCHOR RODS

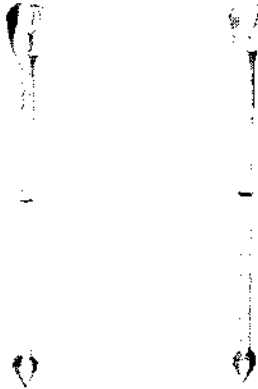

The redesigned eye forms a perfectly shaped "Thimble" and the sidewalls and groove of the eye extend around the head of the rod. This keeps the strand from flattening under tension, preserves its cylindrical shape and prevents it from kinking at any one point. The sidewalls of the groove are formed to fit snugly around the guy strand preventing it from flattening under tension.

### Thimbleye Nevercreep Rods

Cat. No.	Stock No.	Size	Approx. Wt./C
25	(890031)	1/2" x 5'	364
26	(890032)	1/2" x 6'	456
27	(894831)	1/2" x 7'	500
56	(890033)	5/8" x 6'	661
57	(890034)	5/8" x 7'	749
58	(890035)	5/8" x 8'	830
36	(890036)	3/4" x 6'	905

### Twineye Nevercreep Rods

Cat. No.	Stock No.	Size	Approx. Wt./C
560	(894832)	5/8" x 6'	655
570	(894833)	5/8" x 7'	763
580R	(894834)	5/8" x 8'	840

## STAMPED STEEL EXPANSION ANCHORS

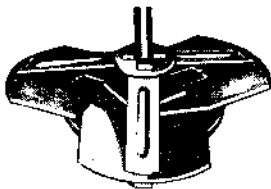

The Kearney Stamped All Steel Anchor combines great structural strength with light weight. Each blade is supported against its earth load by rigid truss members. This principle has made possible the use of flat surface blades, and the elimination of

extra layers of metal. Consequently the blades expand into position with less friction, and unnecessary weight is eliminated.

A tamping collar serves as a hub for the spreader bars, the opposite ends of which are attached to the blades. When the anchor is fully expanded, the tamping collar rests on the shoulder of the central guide post. As pull is applied to the anchor rod, the spreader bars come under tension and serve as guy trusses to provide blade rigidity and prevent any tendency of the blades to bend.

The base plate is cup shaped for maximum strength, and provides supporting pressure throughout its entire circumference. A nut retainer permits salvaging the anchor rod and prevents the anchor traveling up the rod during installation.

### 2-Way Stamped Steel Anchor

Cat. No.	Stock No.	Anchor and Hole Size	Rod Size	Sq. In. Area Anchor	Sq. In. Area Undisturbed Earth	Holding Power, Pounds			Approx. Ship. Wt. per 100
						Ordinary	Clay	Hard Pan	
80090	(894822)	8"	5/8" to 3/4"	90	40	7,500	9,500	14,000	825 lbs.

### 3-Way Stamped Steel Anchor

80110	(894823)	8"	5/8" to 3/4"	110	60	9,500	12,500	16,000	1,050 lbs.
-------	----------	----	--------------	-----	----	-------	--------	--------	------------

## HUBBARD HUBEYE ANCHOR RODS Hot Galvanized

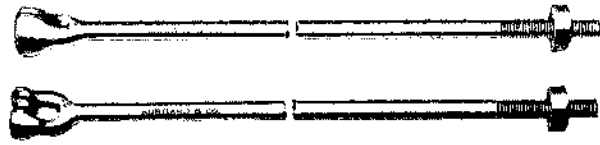

Designed to provide a smooth curve with an ample radius for protection to the strand at the bend, thereby eliminating the use of a guy thimble. The strength of the Hubeye is greater than that of the rod.

The Tu-Hubeye, for two guys, is forged with the same generous radius as the Hubeye.

### Hubeye Only

1/2" Diameter Rod			5/8" Diameter Rod			
Cat. No.	Stock No.	Ship. Wt. Lb. per 100	Overall Length Feet	Cat. No.	Stock No.	Ship. Wt. Lb. per 100
8405	(894005)	370	5	8415	(894008)	550
8406	(894006)	440	6	8416	(894009)	654
8407	(894007)	500	7	8417	(894010)	758
	( )		8	8418	(894011)	862

### Hubeye

### Tu-Hubeye

3/4" Diameter Rod			1" Diameter Rod			
Cat. No.	Stock No.	Ship. Wt. Lb. per 100	Overall Length Feet	Cat. No.	Stock No.	Ship. Wt. Lb. per 100
8426	(894012)	960	6	8526	(894018)	1000
8427	(894013)	1145	7	8527	(894019)	1195
8428	(894014)	1400	8	8528	(894020)	1440
8429	(894015)	1460	9	8529	(894021)	1500

Cat. No.	Stock No.	Ship. Wt. Lb. per 100	Overall Length Feet	Cat. No.	Stock No.	Ship. Wt. Lb. per 100
8438	(894016)	2300	8	8538	(894022)	2400
8440	(894017)	2800	10	8540	(894023)	2860

## HUBBARD ANCHOR RODS Hot Galvanized

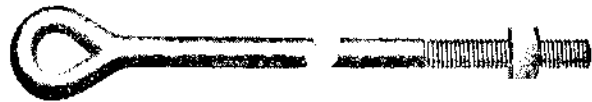

Standard oval eye anchor rod used to form the dead-man type of anchorage. The eye is drop forged and is stronger than the rod itself. Diameters of 3/4 inch or under have rolled threads, larger diameters have cut threads. All rods threaded 3 1/2 inches.

Cat. No.	Stock No.	Diam. Rod Inches	Overall Length Feet	Width Eye Inches	Length Eye Inches	Shipping Wt. Lb. per 100
7355	(891883)	1/2	5	1 1/4	1 1/2	350
7356	(891884)	1/2	6	1 1/4	1 1/2	405
7357	(891885)	1/2	7	1 1/4	1 1/2	510
7415	(891886)	5/8	5	1 1/2	2	550
*7416	(891887)	5/8	6	1 1/2	2	650
†7417	(891888)	5/8	7	1 1/2	2	750
*7418	(891889)	5/8	8	1 1/2	2	850
7426	(891890)	3/4	6	1 1/2	2	910
7427	(891891)	3/4	7	1 1/2	2	1060
*†7428	(891892)	3/4	8	1 1/2	2	1220
7429	(891893)	3/4	9	1 1/2	2	1360
7438	(891894)	1	8	1 1/2	2	2265
*7440	(891895)	1	10	1 1/2	2	2735

\*EEI Standard †ARA Standard

**HUBBARD STEELWING ANCHORS**  
Hot Galvanized



Large bearing surface and sharp edged entering blades enable anchor to be easily installed and provide efficient and substantial anchorage against undisturbed earth; will not creep. No parts can come loose during installation or salvage.

All eyes—Hubeye, Three Hubeye and Oval Eye—are sufficiently large to allow for the insertion of a bar for turning. The single Hubeye accommodates a single guy; the Three Hubeye handles one, two or three guys.

**Three Hubeye**

Cat No.	Stock No.	Wing Dia. In.	Rod Dia. In.	Over all Ft.	Approx. Ship. Wt. Lb. per 100
7527	(894715)	7	1	5½	1750
7528	(894716)	8	1	5½	2000
7530	(894717)	10	1¼	5½	3200
7550	(894718)	10	1¼	8	4300

**Single Hubeye**

Cat No.	Stock No.	Wing Dia. In.	Rod Dia. In.	Over all Ft.	Approx. Ship. Wt. Lb. per 100
7524-SE	(890053)	4	¾	4½	800
7526-SE	(890054)	6	¾	5½	1100
7527-SE	(890055)	7	1	5½	1750
7528-SE	(890056)	8	1	5½	2000
7530-SE	(890057)	10	1¼	5½	3200
7550-SE	(890058)	10	1¼	8	4300

**EEE Oval Hubeye**

Cat No.	Stock No.	Wing Dia. In.	Rod Dia. In.	Over all Ft.	Approx. Ship. Wt. Lb. per 100
*7542	(894719)	2¾	½	1½	130
7543	(894720)	2¾	½	2½	200
7524-A	(894721)	4	¾	4½	800
7526-A	(894722)	6	¾	5½	1100
7527-A	(894723)	7	1	5½	1750
7528-A	(894724)	8	1	5½	2000
7530-A	(894725)	10	1¼	5½	3200
7550-A	(894726)	10	1¼	8	4300

\*Open eye

**HUBBARD COPPERWELD GROUND ROD CLAMPS**

**Type A**



The great strength and high elastic limit of these non-ferrous clamps enable them to maintain permanently low resistance ground connections. They accommodate solid or stranded ground wires and are furnished with either safety set screws or square head set screws.



No. 9492  
Type A Clamp  
With Safety Set  
Screw

No. 9592  
Type A Clamp  
With Square Head  
Set Screw

**Type B**



Type "B" Clamps are designed to allow the use of Hubbard-Copperweld Ground Rods and Clamps at a lower assembly cost. They provide a permanent high pressure connection which is made quickly without the use of solder.



No. 6492  
Type B  
With Safety Set  
Screw

Safety  
Screw  
Wrench

No. 6592  
Type B  
With Square Head  
Set Screw

Safety Screw Type No.	Stock No.	Rod Dia. In.	Wire Size	Approx. Ship. Wt. Lbs., 100 Pcs.
9490	(891956)	¾	6 to 12 AWG Solid	15
9491	(891957)	½	4 to 10 AWG Solid	25
9492	(891958)	⅝	2 to 8 AWG Solid	35
9493	(891959)	¾	2 to 8 AWG Solid	45
9495	(891960)	1	2 to 8 AWG Solid	50

Safety Screw Type No.	Stock No.	Rod Dia. In.	Wire Size	Approx. Ship. Wt. Lbs., 100 Pcs.
6490	(891968)	¾	6 to 14 AWG Solid	8
6491	(891969)	½	2 to 10 AWG Solid	15
6492	(891970)	⅝	2 to 8 AWG Solid	30
6493	(891971)	¾	2 to 8 AWG Solid	40

Sq. Hd. Bolt Type No.	Stock No.	Rod Dia. In.	Wire Size	Approx. Ship. Wt. Lbs., 100 Pcs.
9590	(891962)	¾	6 to 12 AWG Solid	15
9591	(891963)	½	4 to 10 AWG Solid	25
9592	(891964)	⅝	2 to 8 AWG Solid	35
9593	(891965)	¾	2 to 8 AWG Solid	45
9595	(891966)	1	2 to 8 AWG Solid	50

Sq. Hd. Bolt Type No.	Stock No.	Rod Dia. In.	Wire Size	Approx. Ship. Wt. Lbs., 100 Pcs.
6590	(891972)	¾	6 to 14 AWG Solid	8
6591	(891973)	½	2 to 10 AWG Solid	15
6592	(891974)	⅝	2 to 8 AWG Solid	30
6593	(891975)	¾	2 to 8 AWG Solid	40

## HUBBARD STEEL GROUND RODS

### Hot Galvanized With Copper Wire

The wired rod has a length of No. 12 gage copper wire bonded firmly to upper end with five inches free for making ground wire connection.

All possibility of wire stripping loose is eliminated by the top turn being looped under itself, relieving the bond from carrying strain concentrated at that point. Special lengths of wire can be furnished.

Cat. No.	Stock No.	Diam. Inches	Lgth. Feet	Shipping Wt. Lb. per 100
*9505	(891952)	1/2	5	365
9506	(891953)	1/2	6	418
9516	(891954)	5/8	6	660
9538	(891955)	1	8	2420

\*A. T. & T. Co. Std.

### Without Copper Wire

Ground rod without wire has a hole at the upper end for attaching ground wire. Hole is located 1 inch from the upper end of rod.

Cat. No.	Stock No.	Diameter In. Hole Inches	Length Feet	Shipping Wt. Lb. per 100
9555	(891943)	3/8	1/8	5 203
9556	(891944)	3/8	1/8	6 245
9565	(891945)	1/2	5/32	5 346
9566	(891946)	1/2	5/32	6 415
9567	(891947)	1/2	5/32	7 484
9576	(891948)	5/8	3/16	6 650
9577	(891949)	5/8	3/16	7 750
9578	(891950)	5/8	3/16	8 850

Without Copper Wire

## HUBBARD-COPPERWELD GROUND RODS



Offers the permanence of copper plus the strength of steel. Made by molten weld process which assures a permanent bond between the copper and the steel.

### With Wire Tail

Cat. No.	Stock No.	Lgth. Ft.	Approx. Ship. Wt. per 100
7775	(891937)	5	225
7776	(891938)	6	265

### 1/2-In. Diam.

7795	(891939)	5	365
7796	(891940)	6	435
7797	(891941)	7	505
7798	(891942)	8	575

### Ground Rods

#### Without Wire Tail

Cat. No.	Stock No.	Lgth. Ft.	Approx. Ship. Wt. per 100
9415	(891908)	5	200
9416	(891909)	6	240
9387	(891910)	7	280
9388	(891911)	8	320

### Without Wire Tail (Cont.)

Cat. No.	Stock No.	Lgth. Ft.	Approx. Ship. Wt. per 100
9425	(891912)	5	340
9426	(891913)	6	410
9427	(891914)	7	480
9428	(891915)	8	550
9429	(891916)	9	615
9430	(891917)	10	685

### 5/8-In. Diam.

9435	(891918)	5	535
9436	(891919)	6	640
9437	(891920)	7	750
9438	(891921)	8	855
9439	(891922)	9	960
9440	(891923)	10	1070

### 3/4-In. Diam.

9445	(891924)	5	775
9446	(891925)	6	930
9447	(891926)	7	1085
9448	(891927)	8	1240
9449	(891928)	9	1395
9450	(891929)	10	1550

### 1-In. Diam.

9466	(891930)	6	1650
9467	(891931)	7	1925

## RELIABLE GROUND ROD CLAMPS



Reliable ground rod clamps provide high pressure contact directly between wire and rod—giving maximum conductivity and maintaining a fine joint under all conditions at very low cost. The design of this clamp makes economical use of a tough, corrosion resistant material. The heavy embossed everdur body springs slightly under stress and tends to lock the threads. This clamp will not vibrate loose and will stand repeated re-use. Clearly marked with rod size.

Made of everdur for copper and copperweld ground rods. Made of steel, galvanized and tinner, for steel ground rods.

### Bronze Clamps for Copper and Copperweld Rods

Cat. No.	Stock No.	Rod Size		Wire A.W.G.		Std. Pkg.	Ship. Wt. Lb. per C
		Max.	Min.	Max.	Min.		
E48	(891760)	1/2"	3/8"	1	14	100	10
E58	(891762)	5/8"	1/2"	3/0	14	100	17
E68	(891764)	3/4"	5/8"	3/0	14	100	20

### Galvanized Steel Clamps For Steel Rods and Pipes

Cat. No.	Stock No.	Rod Size		Wire A.W.G.		Std. Pkg.	Ship. Wt. Lb. per C
		Max.	Min.	Max.	Min.		
S48	(891761)	1/2"	3/8"	1	14	100	10
S58	(891763)	5/8"	1/2"	3/0	14	100	17
S68	(891765)	3/4"	5/8"	3/0	14	100	20

## STATION GROUND CLAMPS

### For Grounding of Communication Circuits



For telephone, radio and signal circuit station grounds. For 3/8" to 1 1/4" pipe. Made of round edge copper strip. The screws and nuts have close fitting threads.

Cat. No.	Stock No.	Rod Size		Std. Pkg.	Ship. Wt. Lb. per C
		Max.	Min.		
1	(891759)	1 1/4"	3/8"	100	6

## GALVANIZED STEEL KLING KLAMPS

### For Steel Rods and Pipes

Reliable Kling Klamps are heavily galvanized and provided with tinned washers to clamp small copper or iron ground wires. Galvanized steel set screws have cupped points to bite into rods and insure good contact.

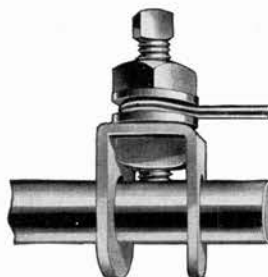

Cat. No.	Stock No.	Rod Size		Wire A.W.G.		Std. Pkg.	Ship. Wt. Lb. per C
		Max.	Min.	Max.	Min.		
K48	(891766)	1/2"	3/8"	2	14	100	14 1/2
K58	(891767)	5/8"	1/2"	2	14	100	15

## CROSS-OVER CLAMPS Hot Galvanized

Used for joining two cable messengers when they cross each other at right angles. For telephone work where cables turn corners, or where branch cables leave line at points distant from poles.



Cat. No.	Stock No.	Size Inches	Ship. Wt. Lb. per 100
8930	(891696)	3 1/4 x 1 1/2 x 1/2	162

**GUY CLAMPS**  
Hot Galvanized

This guy clamp is hot rolled to 5/8-inch thickness from steel plate.

Clamp bolts are made of special steel to prevent elongation and to eliminate stripping. Heads are made large to provide maximum clamping area and shoulders trap the bolts to prevent turning while tightening.

All sizes with three or more bolts are shipped with bolts reversed.



**Heavy Type—5/8-Inch Clamp Bolts**

Cat. No.	Stock No.	No. of Bolts	Lgth. In.	Width Inches	Size Strand Inches	Approx. Ship. Wt. Lb. per 100
7460	(891712)	3	6	2 1/8	3/8-5/8	365
*7461	(891713)	3	6	2 1/32	5/16-1/2	284
7462	(891714)	2	4	2 1/32	5/16-1/2	174
7464	(891715)	4	8	2 1/32	5/16-1/2	365

**Medium Type—1/2-Inch Clamp Bolts**

Cat. No.	Stock No.	No. of Bolts	Lgth. In.	Width Inches	Size Strand Inches	Approx. Ship. Wt. Lb. per 100
7447	(891716)	1	17/16	1 9/16	1/4-7/16	63
†7448	(891717)	2	3 3/8	1 9/16	1/4-7/16	132
7449	(891718)	3	4	1 9/16	1/4-7/16	185
†7450	(891719)	3	6	1 9/16	1/4-7/16	246

**Light Type—1/2-Inch Clamp Bolts**

Cat. No.	Stock No.	No. of Bolts	Lgth. In.	Width Inches	Size Strand Inches	Approx. Ship. Wt. Lb. per 100
7401	(891720)	1	1 3/4	1 9/32	1/8-1/4	48
7402	(891721)	2	3 3/4	1 9/32	1/8-1/4	106
7403	(891722)	3	5 3/4	1 9/32	1/8-1/4	160
7404	(891723)	4	7 3/4	1 9/32	1/8-1/4	210
7445	(891724)	1	1 1/4	1 1/4	1/8-7/32	52

\*A. T. & T. Co. Std. †Western Union Std. ‡E. E. I. Standard.  
§A. R. A. Standard.

**GUY CLAMPS**  
Hot Galvanized



Furnished with high carbon, heat-treated track bolts. Galvanized insures clean threads.

One and two bolt clamps are for 1/4-inch and larger strand. All others are for 5/16-inch and larger strand.

No. J931 has reversible center bolts.

**Smooth Groove**

Cat. No.	Stock No.	Description	Size Bolt In.	Size Plate Inches	Wt. Lb. per 100
J1061	(891728)	1 Bolt 1 3/8 Inch	1/2	1 9/16 x 3/8	62
J1030	(891729)	2 Bolt 3 3/8 Inch	9/16	1 9/16 x 3/8	132
J930	(891730)	3 Bolt 6 Inch Std.	9/16	1 3/8 x 1 1/32	246
J931	(891731)	3 Bolt 6 Inch Heavy	5/8	1 2 1/32 x 3/8	284
J933	(891733)	4 Bolt 8 Inch Heavy	5/8	1 2 1/32 x 3/8	366

**CROSBY CLIPS**

**Drop Forged—Hot Galvanized**

Cat. No.	Stock No.	Size Inches	Std. Pkg.	Wt. Lb. per 100
J1038	(891739)	1/4	500	30
J1039	(891740)	5/16	500	29
J1040	(891741)	3/8	500	32
J1041	(891742)	7/16	200	67
J1042	(891743)	1/2	200	68
J1043	(891744)	5/8	150	97
J1044	(891745)	3/4	100	149
J1045	(891746)	7/8	50	230
J1046	(891747)	1	50	267
J1047	(891748)	1 1/4	Bbl.	440



**HUBBARD WIRE ROPE CLIPS**



No. 8484

Cat. No.	Stock No.	Size Strand In.	Wt. Lb. per 100
8480	(891749)	1/4	14
8481	(891750)	5/16	16
8482	(891751)	3/8	22
8484	(891752)	1/2	40
8485	(891753)	5/8	55
8486	(891754)	3/4	85
8487	(891755)	7/8	125
8488	(891756)	1	145

**HUBBARD VISE CLIPS**

**Hot Galvanized**



Hubbard vise clips consist of an assembly of two carriage bolts and two clamping members. Their advantage lies in the larger gripping area provided by the top half.

There are no sharp edges or corners to injure the strand. Bolt heads are prevented from turning by a shoulder trapped in the top.

Cat. No.	Stock No.	Size Strand Inches	Diam. Carriage Bolts Inches	Approx. Ship. Wt. Lb. per 100
5448	(891757)	5/16	7/16	65
5449	(891758)	3/8	7/16	95

**SPAN CLAMPS**

**Hot Galvanized**

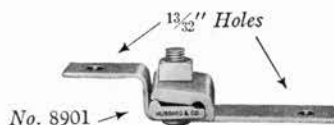

No. 8901 Clamp

No. 8918



No. 8918 Span Clamp is used with No. 9225 Knob for taking off telephone service connections between spans. It consists of a clamp and spacer with holes for two knobs.

No. 8917 is for the same purpose but is used in connection with wire clamps which attach through the wire attachment loop.

Catalog No.	8917	8918
Stock No.	(891737)	(891738)
Size Strand	inches 1/4-3/8	1/4-7/16
Length Cable Groove to Wire Attachment Loop	3 1/4 in.	—
Insulator Spacing	inches —	5 3/4
Approximate Shipping Weight per 100	lb. 46	138

## SERVISLEEVES Hot Galvanized



For effectively and uniformly serving strand. Servisleeve overcomes objectional cutting, clipping and crimping. Easily and quickly installed. Drives on and stays put. No special tools needed.

Cat. No.	Stock No.	Size Strand Inches	Length Inches	Approx. Ship. Wt. Lb. per 100
7451	(891787)	3/16	1 1/4	2
7452	(891788)	1/4	1 1/4	3
7453	(891789)	5/16	1 1/2	5

## DIAMOND GRADE CLAMPS

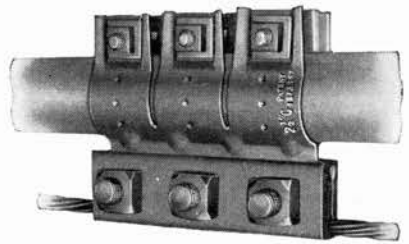

Used two on each side of a pole to overcome the tendency of cables to slide when the messenger is set on a grade.

Three upper bolts and guy clamp are standard equipment which is not regularly furnished with the grade clamp, the same usually being supplied by the telephone company or its supplier.

Size Inches	Stock No.	Maximum Cable Diameter Inches	No. in Carton	Ship. Wt. Lb. per 100 Complete
2 1/2 A	(891706)	1 1/2	25	110
2 1/2 B	(891707)	1 11/16	25	112
2 1/2 C	(891708)	1 15/16	25	114
3	(891709)	2 1/2	25	130
3 1/2	(891710)	2 5/16, 2 3/8	20	140
4	(891711)	2 11/16, 3 1/4	15	165

## HUBBARD CABLE SUSPENSION CLAMPS Hot Galvanized



No. 8901

No. 8903

For use over a through bolt which is also employed as a clamp bolt. One or more nuts or washers are generally used between clamp and pole to provide clearance.

Catalog No.	8901	8903
Stock No.	(891694)	(891695)
Type	1-Bolt	3-Bolt
Overall length	inches 2 3/8	inches 5 3/8
Mounting Hole Diameter	inches 1 1/16	inches 1 1/8 x 15/16
Strand Size	inches 1/4 to 7/16	inches 1/4 to 7/16
Shipping Weight per 100	lb. 84	lb. 224

## KEARNEY GRADE CLAMPS

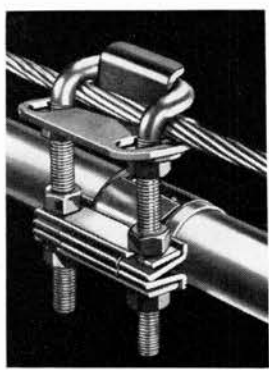

This clamp is completely adjustable to fit all sizes strand, cable rings and cable.

It is rigid and easily develops the full strength of cable sheath without tipping.

The Kearney Grade Clamp is exceptionally easy to install being entirely a one-piece unit. No nuts or bolts are taken apart for any of the placing operations.

This clamp is provided with three band sizes to fit all cables on one strand.

All of the clamps will securely hold the smallest cables and will accommodate the maximum sizes shown below:

Cat. No.	Stock No.	Maximum Cable Size (Outside Diameter)	Approx. Ship. Wt. per 100
7551	(891703)	1" O.D.	110 lbs.
7551-1	(891704)	1 3/8" O.D.	112 lbs.
7551-2	(891705)	2 5/8" O.D.	114 lbs.

## HUBBARD GUY THIMBLES Hot Galvanized



No. 7593

Cat. No.	7593	7594	7595
Stock No.	(892065)	(892066)	(892067)
Size Strand	inches 3/8	inches 1/2	inches 5/8
Size Guy Rod	inches 1/2 & 5/8	inches 5/8 & 3/4	inches 1
Ship. Wt. per 100	lb. 11	lb. 21	lb. 42

## HUBBARD STRAIN PLATES Hot Galvanized

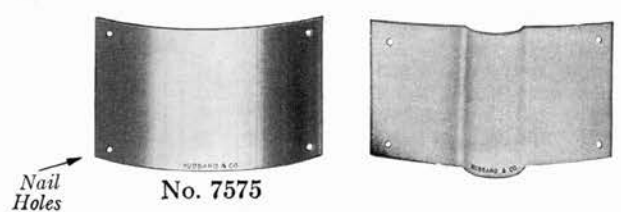

Nail Holes

No. 7575

Used to protect the pole fibres from being cut by messenger or guy strand.

Furnished standard, with offset to fit 1 1/4-inch maximum diameter ground wire moulding.

Catalog No.	7575	7576
Stock No.	(891847)	(891848)
Type	Stand.	Mould.
Dimensions	inches 4x8	inches 4x8
Gage	14	14
Ship. Wt. per 100	lb. 95	lb. 95

**GUY WIRE PROTECTORS**  
Hot Galvanized

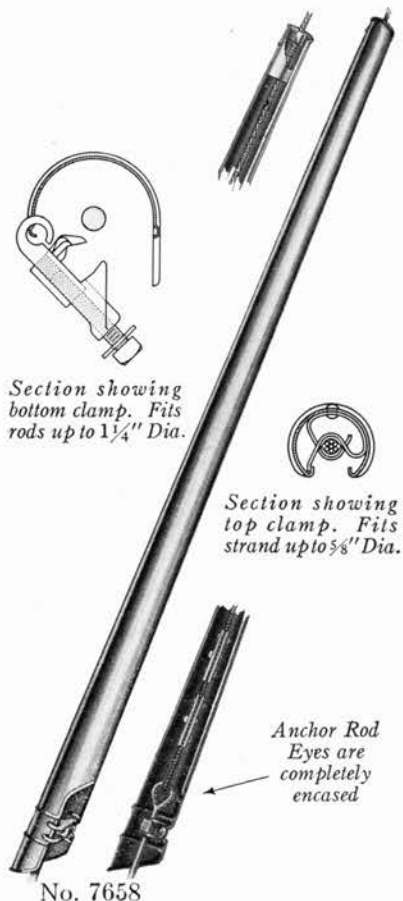

**Loxfast Type**

Top attachment accommodates strand up to 5/8-inch diameter. Bottom clamps are adjustable to fit rods up to 1 1/4 inches in diameter.

**Loxfast-Light**

Cat. No.	Stock No.	Overall Length Feet	Diameter, In.		Steel Gage	Ship. Wt. Lb. per 100
			Top	Bottom		
7657	(891980)	7	2	3 3/4	18	1100
7658	(891981)	8	1 3/4	3 3/4	18	1200

**Loxfast-Heavy**

27657	(891982)	7	2	3 3/4	16	1400
27658	(891983)	8	1 3/4	3 3/4	16	1550

**HUBBARD LOAD OR BREAST PLATES**

Hot Galvanized

Used as back bearing plates when either the guy loop and saddle or the straight-away loop and saddle are subject to heavy strains.

The curved plate is provided with one hole and one slot on four-inch centers.

Catalog No.	8877	8878
Stock No.	(891809)	(891810)
Bolt Hole	in. 3/4	7/8
Bolt Slot	in. 3/4 x 1 1/4	7/8 x 1 1/2
Hole Spacing	in. 4	4
Size Steel	in. 7 x 2 1/2 x 1/4	7 x 2 1/2 x 1/4
Ship. Wt. per 100	lb. 112	112



**MATTHEWS STAZRITE GUY GUARDS**  
Hot Galvanized

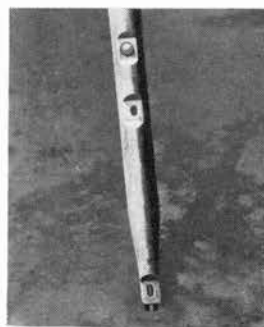

This guy guard cannot be turned or twisted or torn off the guy wire under the most severe conditions. Available in two types, half-round and full-round.

Designed so that it will cover the guy rod and guy wire to the ground line even if guy rod extends above the ground as much as 3 feet.

One-piece construction. Requires no special tools for installing. The patented upper clamping member is an integral part of the

guard and securely locks on the guy wire without damage to the galvanizing on the guy wire or guard.

Complete ventilation is provided around the guy wire to prevent accumulation of moisture which would tend to corrode guy wire and guard.

Cat. No.	Stock No.	Description	Overall Length Feet	Gage	No. in Std. Pkg.	Wt. Lb. per 100
1473	(891984)	Half Round	7	14	5	900
1483	(891985)	Half Round	8	14	5	1100
7016	(891986)	Full Round	7	16	3	1200
7118	(891987)	Full Round	7	18	3	1000
8016	(891988)	Full Round	8	16	3	1300
8118	(891989)	Full Round	8	18	3	1100

**HUBBARD HOOK TYPE STRAIN PLATE**



Used to protect the pole fibers from being cut by messenger or guy strand.

No. 7577 has a welded hook, one 1 1/16-inch guy hook and hole, and two 7/16-inch lag screw holes.

Catalog No.	7577
Stock No.	(891849)
Type	Heavy Guy Hook
Dimensions	inches 4 x 8
Gage	14
Ship. Wt. per 100	lb. 134

**HUBBARD FLAT LIFT PLATES**

No. 8891 measures 7 x 2 1/2 x 5/16 inches and has two 9/16-inch holes, one 1 1/16-inch hole, and one 1 1/32-inch hole.

Catalog No.	*8891
Stock No.	(891814)
Bolt Diameter	in. 1
Size Bolt Hole	in. 1 3/32
Plate Thickness	in. 5/16 Flat
Approx. Ship Wt. per 100	lb. 151
*A. T. & T. Co. Std.	



## HUBBARD CURVED LIFT PLATES



### Hot Galvanized

These plates are used under the eye of Hubeye angle bolts to distribute the strain of down-guys over a greater area.

Dimensions, 7 x 2½ in.  
All plates curved.

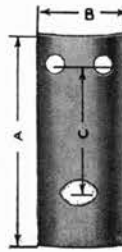

No. 8887

No. 8837

Cat. No.	Stock No.	Diam. Bolt In.	Size Bolt Hole In.	Thick Plate Inches	At. tch. No.	Holes Diam. In.	Ship. Wt. Lb. per 100
8887	(891811)	5/8	1 1/16 x 1 5/16	3/16	1	9/16	99
8888	(891812)	3/4	1 3/16 x 1 1/16	1/4	1	9/16	128
8889	(891813)	1	1 1/16 x 1 5/16	5/16	1	9/16	151
8897	(891815)	5/8	1 1/16 x 1 5/16	3/16	2	9/16	95
8898	(891816)	3/4	1 3/16 x 1 1/16	1/4	2	9/16	124
8899	(891817)	1	1 1/16 x 1 5/16	5/16	2	9/16	148

## HUBBARD GUY HOOKS

### Hot Galvanized



No. 7584

No. 7585

No. 7586

Necessary to meet the needs of various operating companies, both power and communication.

Constructed with rounded wire grooves to give the strand a safe bending radius. Made of steel.

Catalog No.	7583 1/2	7584	7585	7586
Stock No.	(891799)	(891800)	(891801)	(891802)
Description	Light	Med.	Hvy.	Hvy.
Material	inches 1/4 x 1 1/4	3/8 x 1 3/4	3/8 x 1 1/2	3/8 x 1 1/2
Length	inches 3 3/4	4	3 1/2	6
Upper Hole Diameter	inches			9/16
Lower Hole Diameter	inches	9/16	1 1/16	9/16
Ship. Wt. per 100	pounds	40	89	65
				91

## HUBBARD GUY SHIMS

### Hot Galvanized



Six or more guy shims are used per pole to prevent messenger or guy strand from cutting into the wood.

Diameter of nail holes, 1/4-inch.

Catalog No.	7570	7571
Stock No.	(894075)	(891808)
Dimensions	inches 1 7/32 x 7 7/32 x 8	1 1/4 x 3 1/16 x 8
Ship. Wt. per 100	pounds 57	68

## STORM GUY HOOKS

### Hot Galvanized

Necessary to meet the needs of various operating companies, both power and communication.

Generally mounted back to back.

Constructed with rounded wire grooves to give the strand a safe bending radius.

Made of steel.



No. 6001

Cat. No.	Stock No.	Description	Length Steel Inches	Hole Diam. Inches	Upper	Lower	Approx. Ship. Wt. Lb. per 100
*6001	(891803)	Storm	1/4 x 1 1/2 x 7	9/16	13/16	13/16	107
6002	(891804)	Storm	1/4 x 2 x 7 1/4	9/16	13/16	13/16	170
6004	(891805)	Crossarm	1/4 x 1 1/2 x 4 1/8	—	1 1/16	—	100

\*A. T. & T. Co. standard.

## REINFORCING LINKS

### Hot Galvanized

Used to relieve side strains at angles in the line. Will stand strains of 4000 pounds.



No. 8929

Cat. No.	Stock No.	Length Over All, In.	Size Steel In.	Diam. Mounting Hole, In.	Approx. Ship. Wt. Lb. per 100
8919	(891806)	5 3/4	1/2	9/16	102
8929	(891807)	8 3/8	1/2	9/16	125

## HUB GUARDS

### Hot Galvanized



Used on wood poles to protect them from the hubs of vehicles. The dimensions given below are those of the flat plates, before bending, the 14-inch guards having a 5 1/2-inch radius, and the 16-inch guards, a 7 1/2-inch radius.

All holes are 9/16-inch diameter for 1/2-inch lag screws.

Cat. No.	Stock No.	Dimensions Inches	Approx. Ship. Wt. Lb. per 100
*7101	(891790)	16 x 18 x 1/8	1200
†7102	(891791)	14 x 30 x 3/16	2300
†7103	(891792)	16 x 30 x 3/16	2500

\*A. T. & T. Co. standard.  
†Western Union standard.

## REINFORCING AND SAFETY STRAPS

### Hot Galvanized



No. 8905 No. 8906 No. 8907

This strap is used as an added safeguard for cable suspension clamps at points of extreme stress.

No. 8905 is employed to reinforce the messenger bolt. No. 8906 is a safety strap to prevent the cable from falling if the messenger gives away. No. 8907 combines the two items in one piece.

Cat. No.	Stock No.	Description	Size Steel In.	Approx. Ship. Wt. Lb. per 100
8905	(891725)	Reinforcing Strap	1 1/2 x 1/8	36
8906	(891726)	Safety Strap	1 3/4 x 1/8	76
8907	(891727)	Combination Strap	1 3/4 x 1/8	116

**UNIVERSAL MESSENGER HANGERS**

**Hot Galvanized**

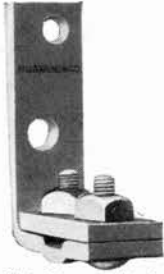

Forged from new, open hearth steel, with a curved wire groove, which permits its use on curves as well as straight runs.

Two 1/2-inch clamp bolts hold the messenger securely in place. The hanger is mounted by means of a 5/8-inch through bolt and a 1/2-inch lag screw.

Cat. No.	Stock No.	Size Steel Inches	Length Legs In.	Size Strand In.	Approx. Ship. Wt. Lb. per 100
8911	(891795)	2 x 1/2	4 7/8 x 4 1/4	5/16 - 1/2	338
8912	(891796)	1 3/4 x 3/8	4 7/8 x 3 3/4	5/16 - 1/2	243

**NON-BREAKABLE MESSENGER HANGERS**

**Hot Galvanized**

This hanger combines spacer and clamp. It is used over a 5/8-inch through bolt and is curved to fit the pole. Messenger is held in place while stringing by the vertical finger.

Made of certified malleable iron.



Cat. No.	Stock No.	Length Clamping Surface, In.	Size Strand Inches	Approx. Ship. Wt. Lb. per 100
8914	(891793)	3	5/16 to 3/8	150
8915	(891794)	3	7/16 to 1/2	150

**PREMAX EMBOSSED ALUMINUM LETTERS AND FIGURES**



Made of 99% pure aluminum rolled especially for this purpose, will neither rust, tarnish nor corrode. Plain finish. Being perfectly smooth, letters and figures do not catch or hold dirt. Standard packing, 100 per carton.

Size In.	Stock No.	Type
1/2	(891357)	Roman Letters and Figures
3/4	(891358)	Roman Letters and Figures
1	(891359)	Roman Letters and Figures
1 1/2	(891360)	Roman Letters and Figures
1 1/2	(891361)	Gothic Figures only
2	(891362)	Roman Letters and Figures
3	(891363)	Roman Letters and Figures
4	(891364)	Roman Letters and Figures
6	(891365)	Roman Letters and Figures

**ESCUTCHEON PINS**

Size In.	Stock No.	Description	No. per Lb.
1	(891366)	No. 15 Galvanized Steel	900
1	(891367)	No. 15 Brass	700
3/4	(891368)	No. 15 Brass	950
5/8	(891369)	No. 15 Brass	1100
5/8	(891370)	No. 15 Cadmium Plated Steel	1200

Smaller or special sizes of pins furnished on request.

**HUBBARD POLE DATING NAILS**



Used for indicating the year or pole heights. Any two numerals may be ordered.

Square head, 9/16-inch. Square shank, 1/4-inch. Length, 2 1/2 inches.

Approximate shipping weight per 100 pieces, 5.5 pounds.

Ordering Note: Use Stock No. (891818) for nails of any date; be sure to specify last two digits of date on the order.

**HUBBARD SQUARE WASHERS**

**Hot Galvanized**



Cleanly cut and smoothly galvanized. There are no irregularities of the zinc coating to interfere with the proper seating of bolt heads or nuts.

Can be supplied with nail holes at slight extra cost.

Cat. No.	Stock No.	Size Inches	Diameter Hole Inches	Bolt Inches	Shipping Wt. Lb. per 100
7811	(892051)	2 x 2 x 1/8	9/16	1/2	16
7812	(892052)	2 x 2 x 1/8	1 1/16	5/8	16
7812 1/2	(892053)	2 x 2 x 3/16	1 3/16	3/4	19
7813	(892054)	2 1/4 x 2 1/4 x 3/16	1 1/16	5/8	25
7813 1/2	(892055)	2 1/4 x 2 1/4 x 3/16	9/16	1/2	25
7814	(892056)	2 1/4 x 2 1/4 x 3/16	1 3/16	3/4	25
7816	(892057)	3 x 3 x 3/16	1 3/16	3/4	53
7817	(892058)	3 x 3 x 1/4	1 3/16	3/4	69
7818	(892059)	4 x 4 x 3/16	1 3/16	3/4	96
7819	(892060)	4 x 4 x 1/4	1 5/16	3/4 & 7/8	127
7819 1/2	(892061)	4 x 4 x 1/2	1 3/16	3/4	218
7820	(892062)	4 x 4 x 1/2	1 3/16	1	251
7826	(892063)	3 1/2 x 3 1/2 x 3/8	1 5/16	3/4 & 7/8	136
7827	(892064)	6 x 6 x 3/8	1 3/16	1	407

**HUBBARD CURVED WASHERS**

**Hot Galvanized**

Cleanly cut and smoothly galvanized. There are no irregularities of the zinc coating to interfere with the proper seating of bolt heads or nuts.

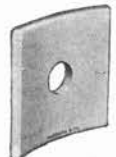

Cat. No.	Stock No.	Size Inches	Diameter Hole Inches	Bolt Inches	Shipping Wt. Lb. per 100
7822	(892048)	2 1/2 x 2 1/2 x 3/16	1 1/16	3/8	34
7823	(892049)	3 x 3 x 1/4	1 3/16	3/4	66
7824	(892050)	3 x 3 x 5/16	1 1/8	1	94
7825	(891872)	3 1/4 x 3 1/8 x 1/4	1 3/16	3/4	85

**HUBBARD ROUND WASHERS**

**Hot Galvanized**



Cleanly cut and smoothly galvanized. There are no irregularities of the zinc coating to interfere with the proper seating of bolt heads or nuts.

Can be supplied with nail holes at slight extra cost.

Cat. No.	Stock No.	O.D. In.	Gage No.	Diameter Hole Inches	Bolt Inches	Shipping Wt. Lb. per 100
7801	(892043)	1	14	7/16	3/8	1.8
7802	(892044)	1 1/4	14	1/2	3/8 Carriage	2.9
7803	(892045)	1 3/8	12	5/16	1/2	4.6
7805	(892046)	1 3/4	10	1 1/16	5/8	9.2
7806	(892047)	2	9	1 3/16	3/4	11.0

## HUBBARD LAG SCREWS Hot Galvanized



Gimlet Point Lag Screw



Fetter Drive Lag Screw

Unless otherwise specified, fetter drive lag screws will be furnished on all orders except for 1/4 and 5/16 inch diameters, which are furnished with gimlet point thread only.

1/4-Inch Diameter				
Cat. No.	Stock No.	Length Inches	Length Thread Inches	Approx. Ship. Wt. Lb. per 100
9722	(891990)	2	1 5/8	3.5
9722 1/2	(891991)	2 1/2	1 3/4	5.0
5/16-Inch Diameter				
9732	(891992)	2	1 3/4	5.2
9732 1/2	(891993)	2 1/2	2	6.2
9733	(891994)	3	2 1/4	7.5
9733 1/2	(891995)	3 1/2	2 1/2	9.7
3/8-Inch Diameter				
9742 1/4	(891996)	2 1/4	2	8.8
9742 1/2	(891997)	2 1/2	2	9.7
9743	(891998)	3	2	11.0
9743 1/2	(891999)	3 1/2	2 1/2	12.8
9744	(892000)	4	2 7/8	14.6
9744 1/2	(892001)	4 1/2	3	16.4
9745	(892002)	5	3	16.9
1/2-Inch Diameter				
9752 1/2	(892003)	2 1/2	2	18.4
9753	(892004)	3	2 1/2	20.9
9753 1/2	(892005)	3 1/2	3	23.4
9754	(892006)	4	2 1/2	26.0
9754 1/2	(892007)	4 1/2	2 7/8	27.8
9755	(892008)	5	3 1/4	32.1
9756	(892009)	6	3	38.3

## HUBBARD CARRIAGE BOLTS Hot Galvanized



Carriage Bolt

Used in attaching braces to cross arms. Furnished with standard heads, shoulders, nuts and rolled threads.

3/8-Inch Diameter				
Cat. No.	Stock No.	Length Inches	Length Thread Inches	Approx. Ship. Wt. Lb. per 100
9633	(891552)	3	1 3/4	14.5
9633 1/2	(891553)	3 1/2	1 3/4	16.5
*†‡§9634	(891554)	4	1 3/4	18.3
*†‡§9634 1/2	(891555)	4 1/2	1 3/4	20.0
§9635	(891556)	5	1 3/4	21.1
9635 1/2	(891557)	5 1/2	1 3/4	22.5
9636	(891558)	6	1 3/4	23.3
1/2-Inch Diameter				
9643	(891559)	3	2 1/2	26.7
9643 1/2	(891560)	3 1/2	3	29.2
9644	(891561)	4	3	33.3
9644 1/2	(891562)	4 1/2	3	36.7
9645	(891563)	5	3	38.6
9645 1/2	(891564)	5 1/2	3	41.2
9646	(891565)	6	3	44.0

†A. T. & T. Co. Std. \*Western Union Std. §E. E. I. Std.  
‡A. R. A. Std.

## HUBBARD MACHINE AND CROSSARM BOLTS Hot Galvanized



Bolts over 6 inches in length are drive pointed. Nuts are included.

3/8-Inch Diameter				
Cat. No.	Stock No.	Length Inches	Length Thread In.	Ship. Wt. Lb. per 100
9603	(891566)	3	3	13.8
9603 1/2	(891567)	3 1/2	3	16.8
9604	(891568)	4	3	18.4
9604 1/2	(891569)	4 1/2	3	18.9
9605	(891570)	5	3	20.1
9605 1/2	(891571)	5 1/2	3	22.8
9606	(891572)	6	3	23.5
1/2-Inch Diameter				
9704 1/2	(891573)	4 1/2	3	36.6
9704 3/4	(891574)	4 3/4	3	38.5
9705	(891575)	5	3	41.6
9706	(891576)	6	3	45.1
9707	(891577)	7	3	51.9
9708	(891578)	8	4	60.6
9710	(891579)	10	4	76.2
9712	(891580)	12	6	85.8
9714	(891581)	14	6	91.6
9716	(891582)	16	6	106.0
9718	(891583)	18	6	121.0
9720	(891584)	20	6	133.0
5/8-Inch Diameter				
9806	(891585)	6	3	80
9807	(891586)	7	3	90
9808	(891587)	8	4	100
9810	(891588)	10	4	113
9812	(891589)	12	6	127
9814	(891590)	14	6	131
9816	(891591)	16	6	157
9818	(891592)	18	6	180
9820	(891593)	20	6	195
9822	(891594)	22	6	213
9824	(891595)	24	6	237
9826	(891596)	26	6	242
9828	(891597)	28	6	259
3/4-Inch Diameter				
9908	(891598)	8	4	165
9910	(891599)	10	4	183
9912	(891600)	12	6	202
9914	(891601)	14	6	228
9916	(891602)	16	6	257
9918	(891603)	18	6	268
9920	(891604)	20	6	303
9922	(891605)	22	6	336
9924	(891606)	24	6	360
9926	(891607)	26	6	382
9928	(891608)	28	6	466

## BOLTS FOR TELEPHONE BRACKETS Hot Galvanized



No. 9603



No. 9232

Used for attaching porcelain knob insulators to Hubbard Pole or House Brackets.

Cat. No.	Stock No.	Type Bolt	Diameter Inches	Length Inches	Approx. Ship. Wt. Lb. per 100
9232	(891222)	Stove	5/16	2	6.6
9233	(891223)	Stove	5/16	3	8.6
9603	(891566)	Machine	3/8	3	13.8
9605 1/2	(891571)	Machine	3/8	5 1/2	22.9

**HUBBARD DOUBLE ARMING BOLTS**  
Hot Galvanized



Furnished with full length thread and four nuts.

Cat. No.	Stock No.	Diameter Inches	Length Overall In.	Ship. Wt. Lb. per 100
9844	(891610)	1/2	14	120
9846	(891611)	1/2	16	129
9848	(891612)	1/2	18	138
9850	(891613)	1/2	20	146
9852	(891614)	1/2	22	163
9854	(891615)	1/2	24	172
9864	(891617)	5/8	14	194
9866	(891618)	5/8	16	200
9868	(891619)	5/8	18	218
9870	(891620)	5/8	20	235
9872	(891621)	5/8	22	253
9874	(891622)	5/8	24	271
9884	(891624)	3/4	14	279
9886	(891625)	3/4	16	301
9888	(891626)	3/4	18	350
9890	(891627)	3/4	20	372
9892	(891628)	3/4	22	383
9894	(891629)	3/4	24	427

**HUBBARD HUBEYE BOLTS**  
Hot Galvanized



Hubbard drop forged straight and angle Hubeye bolts are designed to provide a smooth curve through the eye with a large radius for protection to the strand at the bend, thereby eliminating the use of guy thimbles.

The eyes of the angle Hubeye bolts are forged at a 45° angle to the shank.

Sizes shown are roll-threaded.

All Hubeye bolts are drive pointed.

Straight		Angle		Dimensions, Inches		
Cat. No.	Stock No.	Cat. No.	Stock No.	Lgth. Under Eye	Lgth. of prox. Thread	Ap. Ship. Wt. Lb. per 100
<b>5/8" Diameter</b>						
9058	(891630)	9150	(891637)	8	6	132
9060	(891631)	9151	(891638)	10	6	154
9062	(891632)	9152	(891639)	12	6	176
9064	(891633)	9153	(891640)	14	6	198
9065	(891634)	9153 1/2	(891641)	15	6	209
9066	(891635)	9154	(891642)	16	6	220
9068	(891636)	9155	(891643)	18	6	242
<b>3/4" Diameter</b>						
9078	(891644)	9160	(891651)	8	6	204
9080	(891645)	9161	(891652)	10	6	229
9082	(891646)	9162	(891653)	12	6	255
9084	(891647)	9163	(891654)	14	6	280
9085	(891648)	9163 1/2	(891655)	15	6	306
9086	(891649)	9164	(891656)	16	6	319
9088	(891650)	9165	(891657)	18	6	344

**HUBBARD EYE BOLTS**  
Hot Galvanized  
Standard Oval Eye Bolts



		1/2-Inch Diameter				
Cat. No.	Stock No.	Length Under Eye Inches	Width Eye Inches	Length Eye Inches	Shipping Wt. Lb. per 100	
39937	(891666)	6	1 1/4	1 1/2	82	
39939	(891667)	8	1 1/4	1 1/2	94	
39941	(891668)	10	1 1/4	1 1/2	107	
39943	(891669)	12	1 1/4	1 1/2	120	
39945	(891670)	14	1 1/4	1 1/2	134	
39947	(891671)	16	1 1/4	1 1/2	147	
39949	(891672)	18	1 1/4	1 1/2	160	
39951	(891673)	20	1 1/4	1 1/2	162	
<b>5/8-Inch Diameter</b>						
39956	(891675)	6	1 1/2	2	131	
39958	(891676)	8	1 1/2	2	145	
39960	(891677)	10	1 1/2	2	169	
39962	(891678)	12	1 1/2	2	179	
39964	(891679)	14	1 1/2	2	192	
39966	(891680)	16	1 1/2	2	205	
39968	(891681)	18	1 1/2	2	229	
39970	(891682)	20	1 1/2	2	242	
39972	(891683)	22	1 1/2	2	267	
39974	(891684)	24	1 1/2	2	280	
<b>3/4-Inch Diameter</b>						
39976	(891686)	6	1 1/2	2	195	
39978	(891687)	8	1 1/2	2	213	
39980	(891688)	10	1 1/2	2	231	
39982	(891689)	12	1 1/2	2	248	
39984	(891690)	14	1 1/2	2	277	
39986	(891691)	16	1 1/2	2	308	
39988	(891692)	18	1 1/2	2	345	
39990	(891693)	20	1 1/2	2	374	

**Double Arming Eye Bolts**



Cat. No.	Stock No.	Diam. Rod Inches	Length Under Eye Inches	Ship. Wt. Lb. per 100
29786	(891659)	5/8	16	253
29788	(891660)	5/8	18	267
29790	(891661)	5/8	20	286
29796	(891663)	3/4	16	360
29798	(891664)	3/4	18	376
29800	(891665)	3/4	20	411

**HUBBARD DROP FORGED ANGLE BOLT HUBEYES**  
Hot Galvanized



Used almost exclusively for down guys. Eliminates the use of strain plates, guy hooks, guy thimbles, nails and lag screws and saves from three to five feet of guy strand. Often used on the nut end of a bolt for a down guy attachment with a straight bolt eye under the head of the bolt as a dead-end.

Nos. 1100 and 1101 will take strand 1/2-inch diameter and under.

Catalog No.	1100	1101
Stock No.	(891844)	(891845)
Diameter Bolt	inches 5/8	3/4
Bolt Hole	inches 3/4	7/8
Width Eye	inches 5/8	3/4
Length Eye	inches 1	1
Ship. Wt. per 100	lb. 140	162

## HUBBARD DROP FORGED STRAIGHT BOLT HUBEYES

### Hot Galvanized

Has unthreaded slot to provide clearance for the insertion of bolts. Used for crossarm guying where a circuit has been dead-ended, although it is suitable for many other guying and dead-ending needs.

Follows the standard Hubeye design. Will take strand 1/2 inch diameter and under.

Catalog No. ....	7519	7520
Stock No. ....	(891837)	(891838)
Diameter Bolt .....	5/8	3/4
Bolt Hole .....	1 1/16 x 1	1 3/16 x 1 1/8
Width Eye .....	1 5/16	1 5/16
Length Eye .....	2 1/2	2 1/2
Shipping Weight per 100 .....	138	138



No. 7514



No. 7515

Used extensively for dead-ending and guying. The standard bolt eye may be used for attaching dead-ending insulators to the crossarm. The long type is often used for supporting suspension insulators with a hook in the cap of the upper unit.

Unthreaded slot provides clearance for the insertion of bolt.

### Standard Bolt Eye

Cat. No.	Stock No.	Diam. Bolt In.	Bolt Hole Inches	Width Eye Inches	Length Eye Inches	Ship. Wt. Lb. per 100
7514	(891839)	5/8	1 1/16 x 1 3/16	1 1/8	12 1/32	83

### Long Bolt Eye

7515	(891840)	5/8	1 1/16 x 1 3/16	1 3/8	3 9/32	117
7516	(891841)	3/4	1 3/16 x 1 1/16	1 3/8	3 7/32	119
7517	(891842)	5/8	1 1/16 x 1	1 5/16	2 13/32	109
7518	(891843)	3/4	1 3/16 x 1 1/16	1 5/16	2 13/32	112

## HUBBARD DROP FORGED HUBEYE NUTS

### Hot Galvanized



Used on through bolts, eye bolts, double arming bolts, straight and angle Hubeye bolts, crossarm bolts, anchor rods and for other attachments where it is desired to convert a standard, threaded bolt to a Hubeye bolt.

Commonly used for dead-ending a messenger wire or span guy on the threaded end of an angle Hubeye bolt on the opposite end of which is attached a down guy.

Cat. No.	Stock No.	Diam. Bolt In.	Width Eye In.	Length Eye In.	Ship. Wt. Lb. per 100
7509	(891826)	1/2	7/8	1 1/2	118
7510	(891827)	5/8	7/8	1 1/2	117
7511	(891828)	3/4	7/8	1 1/2	116
7512	(891829)	1	1 1/4	1 11/16	166

## HUBBARD DROP FORGED STANDARD EYE NUTS

### Hot Galvanized

This eye nut requires the use of a thimble. Used on through bolts, eye bolts, double arming bolts, etc. and for other attachments where it is desired to convert a standard threaded bolt to an eye bolt.

Commonly used for dead-ending a messenger wire or span guy on the threaded end of an angle hubeye bolt on the opposite end of which is attached a down guy.



Cat. No.	Stock No.	Diam. Bolt In.	Width Eye In.	Lgth. Eye In.	Ship. Wt. Lb. per 100
7500	(891830)	1/2	1 1/8	1 1/8	55
7501	(891831)	5/8	1 1/8	1 1/8	55
*7502	(891832)	5/8	1 1/2	1 11/16	65
7503	(891833)	3/4	1 1/2	1 11/16	65
7504	(891834)	3/4	1 1/8	1 1/8	40
7505	(891835)	1/2	1 1/8	1 1/8	40
7506	(891836)	5/8	1 1/8	1 1/8	40

\*Western Union Std.

## HUBBARD DROP FORGED BOLT EYES

### Hot Galvanized

Used extensively for dead-ending and guying. The standard bolt eye may be used for attaching dead-ending insulators to the crossarm. The long type is often used for supporting suspension insulators with a hook in the cap of the upper unit.

Unthreaded slot provides clearance for the insertion of bolt.

### Standard Bolt Eye

Cat. No.	Stock No.	Diam. Bolt In.	Bolt Hole Inches	Width Eye Inches	Length Eye Inches	Ship. Wt. Lb. per 100
7514	(891839)	5/8	1 1/16 x 1 3/16	1 1/8	12 1/32	83

### Long Bolt Eye

7515	(891840)	5/8	1 1/16 x 1 3/16	1 3/8	3 9/32	117
7516	(891841)	3/4	1 3/16 x 1 1/16	1 3/8	3 7/32	119
7517	(891842)	5/8	1 1/16 x 1	1 5/16	2 13/32	109
7518	(891843)	3/4	1 3/16 x 1 1/16	1 5/16	2 13/32	112

## HUBBARD TELEPHONE DISTRIBUTING BRACKETS

### Hot Galvanized

#### No. 9200 L House Type

Used at the house end of a telephone service for dead ending twisted pair telephone wires.

Size steel, 3/16 x 1 3/4 inches. Length legs, 3 7/16 and 2 inches.

A. T. & T. Std.

Shipping Weight 56 Pounds per 100 Pieces.

Catalog No. 9200 Stock No. (891226)



No. 9200

#### L Pole Type

For taking off telephone services, or for short runs on poles.

Size steel, 1/4 x 2 inches. Length legs, 4 x 2 inches. Approximate shipping weight, 100 pieces, 97 pounds.

Catalog No. .... 9202

Stock No. .... (891227)

No. of Holes ..... 3

Size Holes ..... inches 1 5/32

## HUBBARD TELEPHONE CORNER BRACKETS

### Hot Galvanized

Used where leads from the pole come to the building at an angle and to carry leads around the corner of a building.



Catalog No. .... \*9204 \*9205

Stock No. .... (891228) (891229)

Mounting Hole Size ..... in. 1 1/32 1 1/32

Insulated Holes ..... in. 1 1/32 1 1/32

Size Steel ..... in. 7/32 x 1 7/32 7/32 x 1 7/32

Length Overall ..... in. 4 3/8 x 2 1/2 8 1/2 x 1 5/16

Ship. Wt. per 100 ..... lb. 66 96

\*Western Union Std.

**HUBBARD POLE REINFORCING MATERIAL**

**Hot Galvanized**

**Through Bolt and Wire Assembly Material**

Cat. No.	Stock No.	Description	Size Inches	Wt. Lb. per 100
7825	(891872)	Curved Washer— $\frac{7}{8}$ -inch Hole	$\frac{1}{4} \times 3\frac{1}{8} \times 3\frac{1}{4}$	85
7892	(894885)	Clip— $\frac{1}{16}$ -inch Hole	$\frac{3}{8} \times 2 \times 3\frac{9}{16}$	97
7894	(894886)	Clip— $\frac{13}{16}$ -inch Hole	$\frac{3}{8} \times 4 \times 4$	234

**Band and Separator Assembly Material**

7764	(891867)	Half Oval Washer— $\frac{11}{16}$ -inch Hole	$1\frac{3}{4} \times 2\frac{3}{8}$ Half Oval	30
7765	(891868)	Saddle— $5\frac{3}{8}$ -inch Radius	$\frac{1}{8} \times 2$	160
7767	(891869)	Saddle— $8\frac{3}{16}$ -inch Radius	$\frac{1}{8} \times 2$	220
7768	(891870)	Reinforcing Band	$\frac{1}{8} \times 2\frac{1}{4} \times 70$	530
7769	(891871)	Reinforcing Band	$\frac{1}{8} \times 2\frac{1}{2} \times 96$	810
7825	(891872)	Curved Washer— $\frac{7}{8}$ -inch Hole	$\frac{1}{4} \times 3\frac{1}{8} \times 3\frac{1}{4}$	85

**Band and Washer Assembly Material**

7760	(891873)	Reinforcing Band	12 Ga. x 2 x 68 $\frac{1}{2}$	400
7761	(891874)	Reinforcing Band	12 Ga. x 2 x 89 $\frac{1}{2}$	510
7764	(891867)	Half Oval Washer— $\frac{11}{16}$ -inch Hole	$1\frac{3}{4} \times 2\frac{3}{8}$ Half Oval	30

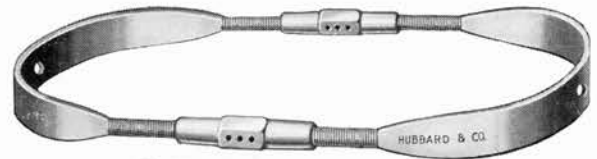

No. 7850 Reinforcing Band  
 $\frac{11}{16}$ " Holes

No. 7852-A  
Casting

No. 7852  
Reinforcing Pipe



No. 7761  
 $\frac{11}{16} \times 3$ " Slots



No. 7769  
 $\frac{11}{16} \times 4\frac{11}{16}$ " Slot

**HUBBARD U-CABLE GUARDS AND STRAPS**

**Hot Galvanized**

When telephone or power cables enter the ground at the base of a pole or the side of a building, they are protected by U-cable guards. The guards are formed of No. 14 gage steel pressed to a U-shape which provides protection for pedestrians as well as providing stiffness for guard.

Nos. 7536 and 7537 have a  $2\frac{1}{8}$ -inch inside diameter belled bottom to fit over ground conduit.

A. T. & T. Co. Standard.

**Type A Assembly Material**

Cat. No.	Stock No.	Description	Size, Inches	Wt. Lb. per 100
†7850	(891853)	Band	12 Ga. x 2 x 68 $\frac{1}{2}$	410
†7851	(891854)	Band	12 Ga. x 2 x 89 $\frac{1}{2}$	525
†7852	(891857)	Pipe	Extra Hvy. 2 x 5	220
7852-A	(891858)	Casting	$5\frac{5}{16}$ Long; $1\frac{1}{2}$ Rad.	220
†7855	(891855)	Band	12 Ga. x 2 x 99	780
†7856	(891856)	Band	12 Ga. x 2 x 120	1000

†A. T. & T. Co. Standard.

**U-Cable Guards**

Cat. No.	Stock No.	Lgth. Feet	Inside Diam. Inches		Shipping Wt. Lb. per 100
			Top	Bottom	
7531	(891875)	6	$1\frac{1}{8}$	$1\frac{1}{8}$	495
7532	(891876)	5	$2\frac{3}{16}$	$2\frac{3}{16}$	825
7533	(891877)	8	$2\frac{3}{16}$	$2\frac{3}{16}$	1408
7534	(891878)	5	$3\frac{3}{16}$	$3\frac{3}{16}$	1210
7535	(891879)	8	$3\frac{3}{16}$	$3\frac{3}{16}$	1925

**Mounting Straps**

Cat. No.	Stock No.	Size Inches	Used with Cable Guard No.	Diam. Holes In.	Ship. Wt. Lb. per 100
7539	(891881)	$\frac{1}{8} \times \frac{3}{4}$	7532-3	$\frac{7}{32}$	23
7540	(891882)	$\frac{3}{16} \times 1$	7534-5	$\frac{11}{32}$	61



**Type B Assembly Material**

Cat. No.	Stock No.	Dimensions, Inches			Wt. Lb. per 100
		Pole Dia.	Stub Dia.	Length of Sleeve Nut	
7750	(891859)	8	8	4 $\frac{1}{2}$	367
7751	(891860)	10	10	6	550
7752	(891861)	12	12	6	625
7753	(891862)	14	14	6	700
7754	(891863)	16	16	6	780

## HIGHWAY CROSSOVER BRACKETS

### Hot Galvanized

These extension angles are used to obtain clearance for carrying telephone wires to houses or over cross lines.

Holes  $\frac{7}{16}$ -inch in diameter are provided for insulator attachments.

No. 2384 has two  $1\frac{1}{16}$ -inch pole mounting holes spaced 10 inches apart, and one  $\frac{7}{16}$ -inch insulator attachment hole in each angle leg at the top.

No. 2385 is adaptable to crossarm spacings of 12, 18 or 24 inches.

Three sets of insulator attachment holes are provided spaced 24 inches apart.

Cat. No.	Stock No.	Dimensions, In. Steel Size	Length	Approx. Ship. Wt. Lb.
2384	(891533)	$1\frac{1}{4} \times 1\frac{1}{4} \times \frac{1}{8}$	72	600
2385	(891534)	$1\frac{1}{2} \times 1\frac{1}{2} \times \frac{1}{4}$	90	1755

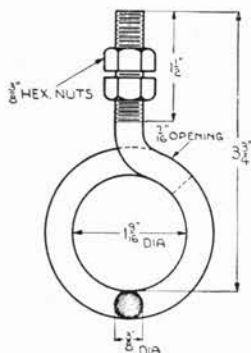
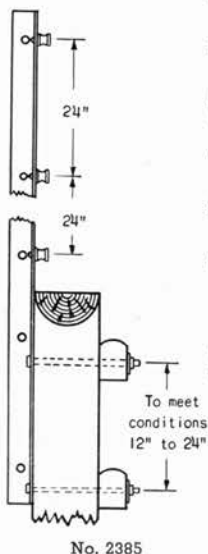

## NO. 2390 HOOK BOLTS

### For No. 2385 Crossover Brackets

Size opening,  $\frac{7}{16}$  inch. Size stock,  $\frac{3}{8}$  inch.

Approximate shipping weight per 100 pieces, 33 pounds.

Stock No. (891535)

## HUBBARD POLE STEPS

### For Wood Poles Hot Galvanized

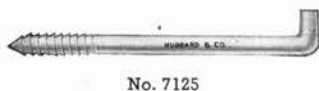

No. 7125



No. 7129



No. 7126

Made of open hearth steel and can be bent to an angle of  $75^\circ$  around its own diameter without fracture. Hook head step has drive head and fetter drive threads. Button head step has twist drive threads and a square shoulder.

Cat. No.	Stock No.	Type Head	Diameter In.	Length Overall In.	Approx. Ship. Wt. Lb. per 100
7123	(891263)	Standard Hook	$\frac{7}{16}$	9	70
7124	(891264)	Standard Hook	$\frac{5}{8}$	9	88
7125	(891265)	Standard Hook	$\frac{5}{8}$	10	94
7126	(891266)	Long Hook	$\frac{5}{8}$	10	116
7128	(891267)	Button	$\frac{5}{8}$	$9\frac{5}{16}$	84
7129	(891268)	Button	$\frac{5}{8}$	$9\frac{11}{16}$	105

## SIDE EXTENSION FIXTURES

### Hot Galvanized

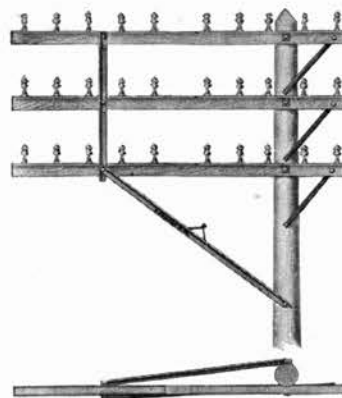

Showing Diagonal, Back and Vertical Braces Assembled

When it is necessary to clear buildings or trees without the use of high poles, these extension fixtures of the A. T. & T. design furnish a rigid and economical construction. Also used to offset arms on a pole where such construction will partially relieve the strain of a slight angle in the line. This method of offsetting is also useful where lines follow country roads with a great many slight bends in both directions. With extension fixtures, the poles may be set at the roadside, and by extending arms either toward the road or away from the road, to compensate for conditions, the wires may be strung in a straight line.

### Diagonal Brace

Diagonal brace is intended for use on both 6 and 10-pin arms. It is provided with a 6-inch step for the lineman and may be used on either side of the pole. It is fastened to the side of the pole by a  $\frac{1}{2}$ -inch lag screw and to the cross arm by a  $\frac{1}{2}$ -inch machine bolt. Made of 2 by 2 by  $\frac{3}{16}$ -inch angle steel. Bolts are not included.

Cat. No.	Stock No.	Dimensions, Inches Overall	Angle	Approx. Ship. Wt. Lb. per 100
8050	(891529)	83	$2 \times 2 \times \frac{3}{16}$	1720

### Back Brace

No. 8051 back brace is used with 6-pin arms, and No. 8052 with 10-pin arms. These braces are attached to the pole by a  $\frac{5}{8}$ -inch through bolt and to the cross arm by a  $\frac{1}{2}$ -inch machine or carriage bolt. Made of 2 by 2 by  $\frac{1}{4}$ -inch angle steel. Bolts are not included.

Cat. No.	Stock No.	Dimensions, Inches Overall	Angle	Approx. Ship. Wt. Lb. per 100
8051	(891530)	$54\frac{1}{2}$	$2 \times 2 \times \frac{1}{4}$	1240
8052	(891531)	$66\frac{7}{16}$	$2 \times 2 \times \frac{1}{4}$	1720

### Vertical Brace—Communication Type

The vertical brace is designed for 3 arms spaced 12 inches apart, or 2 arms on 24-inch centers, additional arms being cared for by placing other vertical braces in series with the first.

Made of  $1\frac{3}{4}$  by  $1\frac{3}{4}$  by  $\frac{1}{4}$ -inch angle and is provided with holes for  $\frac{1}{2}$ -inch bolts. Bolts are not included.

Cat. No.	Stock No.	Dimensions, Inches Overall	Angle	Approx. Ship. Wt. Lb. per 100
8054	(891532)	$30\frac{5}{8}$	$1\frac{3}{4} \times 1\frac{3}{4} \times \frac{1}{4}$	720

**HUBBARD FLAT CROSSARM BRACES**  
Hot Galvanized



No. 8020

Made from new open hearth steel punched for a 1/2-inch through bolt or lag screw at the pole end and 3/8-inch carriage bolts at the arm end.

All standard braces are made with rounded corners.

Cat. No.	Stock No.	Size Steel Inches	Length Over All In.	Ship. Wt. Lb. per 100
8020	(891487)	7/32x1 1/32	20	156
8022	(891488)	7/32x1 1/32	22	172
8024	(891489)	7/32x1 1/32	24	187
8026	(891490)	7/32x1 1/32	26	202
8028	(891491)	7/32x1 1/32	28	218
8030	(891492)	7/32x1 1/32	30	233
8032	(891493)	7/32x1 1/32	32	249
8120	(891494)	1/4 x 1 1/4	20	184
8122	(891495)	1/4 x 1 1/4	22	201
8124	(891496)	1/4 x 1 1/4	24	220
8126	(891497)	1/4 x 1 1/4	26	238
8128	(891498)	1/4 x 1 1/4	28	256
8130	(891499)	1/4 x 1 1/4	30	275
8132	(891500)	1/4 x 1 1/4	32	293

**HUBBARD ALLEY ARM BRACES**  
Hot Galvanized



Used extensively on distribution lines in alleys or where obstructions make it necessary to support wires on one side of pole. Also used at points where poles must be sent slightly out of alignment. Arm being off-set in this case makes it possible to avoid a slight angle in the line.

Two holes for arm adjustment are supplied on Type A. Braces are attached to pole with 1/2-inch lag screws and to arm with 1/2-inch machine bolts. Furnished with steps.

**Type B**

This is the standard brace for side arm mounting.

Cat. No.	Stock No.	Length	Size Angle	Ship. Wt. Lb. per 100
7979	(891501)	5	1 3/4 x 1 3/4 x 3/16	1240
7981	(891502)	5	1 1/2 x 1 1/2 x 3/16	1000
7982	(891503)	6	1 1/2 x 1 1/2 x 3/16	1200
7983	(891504)	7	1 1/2 x 1 1/2 x 3/16	1400
7984	(891505)	7	1 3/4 x 1 3/4 x 3/16	1660
7985	(891506)	10	2 x 2 x 1/4	3800

**HUBBARD VERTICAL BRACES**  
Standard Type  
Hot Galvanized



Cat. No.	Stock No.	No. of Arms	Spac- ing In.	Lgth. Overall Inches	Size Angle Inches	Shipping Wt. Lb. per 100
7976	(891507)	2	18	20	1 1/2 x 1 1/2 x 3/16	300
7977	(891508)	3	18	38	1 1/2 x 1 1/2 x 3/16	520
7978	(891509)	4	18	56	1 1/2 x 1 1/2 x 3/16	840
*7986	(891510)	2	24	26	1 1/2 x 1 1/2 x 3/16	380
*7987	(891511)	3	24	50	1 1/2 x 1 1/2 x 3/16	700
7988	(891512)	4	24	74	1 1/2 x 1 1/2 x 3/16	1040

\*E. E. I. Std.

**HUBBARD CROSSARM BACK BRACES**  
Hot Galvanized

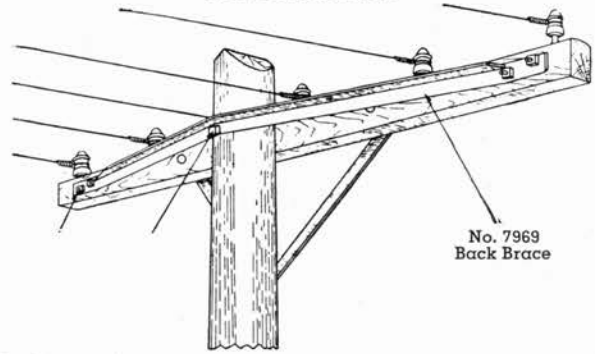

No. 7969 Back Brace

Used to reinforce crossarms at corners and terminal poles and in many cases eliminates the necessity for double arming.

The angles are made of open hearth steel and are attached to the arm by means of two 1/2-inch machine bolts at each end. If vertical brace is not used, crossarm attachment may be made by using 1/2-inch carriage bolts.

Cat. No.	Stock No.	Angle Size In.	Overall Length Inches	Shipping Wt. Lb. per 100
7964	(891524)	1 1/2 x 1 1/2 x 3/16	48	550
7965	(891525)	1 1/2 x 1 1/2 x 3/16	60	825
7966	(891526)	1 1/2 x 1 1/2 x 3/16	72	1200
7967	(891527)	1 3/4 x 1 3/4 x 3/16	94	1540
*7969	(891528)	1 3/4 x 1 3/4 x 3/16	109	2204

\*A. T. & T. Co. Std.

**HUBBARD ANGLE CROSSARM BRACES**  
Hot Galvanized

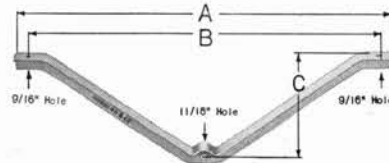

In the construction of heavy pole lines, the one-piece angle steel crossarm brace is in general use. It fastens under the arm with 1/2-inch machine bolts and to the pole with a 3/8-inch through bolt or lag screw. Special sizes supplied on request. When ordering, state size of angle, A, B, and C dimensions, and hole sizes.

Cat. No.	Stock No.	Angle Size In.	A Dimensions In.	B Dimensions In.	C Dimensions In.	Lb. per 100	Ship. Wt.
7948	(891517)	1 1/2 x 1 1/2 x 3/16	51	48	14	974	
7950	(891518)	1 1/2 x 1 1/2 x 3/16	40	37	12	781	
7952	(891519)	1 1/2 x 1 1/2 x 3/16	51	48	14 3/4	979	
7953	(891520)	1 3/4 x 1 3/4 x 3/16	63	60	18	1408	
7954	(891521)	1 3/4 x 1 3/4 x 3/16	69	66	20	1551	
7955	(891522)	1 3/4 x 1 3/4 x 3/16	75	72	18	1639	
7956	(891523)	2 x 2 x 3/16	75	72	22	1958	

**E. E. I. Standard**

No. 7940. For use with E.E.I., 7 foot, 2-pin medium voltage cross-arm.

No. 7942. For use with E.E.I., 10 foot, 4-inch pin, medium voltage crossarm.

No. 7943. For use with E.E.I., special high voltage crossarms.

Cat. No.	Stock No.	Angle Size In.	A Dimensions In.	B Dimensions In.	C Dimensions In.	Lb. per 100	Ship. Wt.
7940	(891513)	1 1/2 x 1 1/2 x 3/16	45	42	12	858	
7941	(891514)	1 1/2 x 1 1/2 x 3/16	51	48	18	1067	
7942	(891515)	1 1/2 x 1 1/2 x 3/16	63	60	18	1210	
7943	(891516)	1 3/4 x 1 3/4 x 3/16	75	72	22	1716	

## HUBBARD POINT TYPE TRANSPOSITION BRACKETS

Hot Galvanized

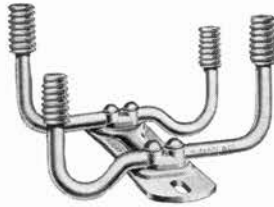

Hubbard point type right and left hand transposition brackets are attached on standard crossarms through adjacent pin holes with 1/2 x 6-inch crossarm bolts fitted with a clipped washer. Both attachment holes are slotted to provide a total of two inches of adjustment.

Mounting hole spacing 10 to 12 inches.

Line spacing 6 3/4 inches.

Base steel size, 1/4 x 3 x 13 5/16 inches.

Point steel size, 3/4-inch round.

## SYSTEM OF TRANSPOSITION

(Patented)

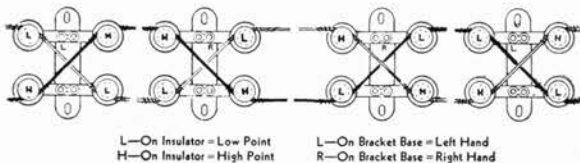

In establishing a transposition of the right and left hand point type, a pair of brackets is employed as shown by the illustration in which one wire is black to distinguish it from the other.

Assuming that a complete transposition is the crossing of one wire over the other and then eventually back to its original position in relation to the other wire, two complete transpositions are shown by the illustration. Note that the first one is black over white and the second is black under the white, maintaining perfect balance. No cutting is necessary, and no tangles result when arms or poles are wrecked as is the case with the spiral type of transposing on the average bracket.

Mounting slots fit standard drilled arms with a 2-inch adjustment range.

Mounting bolts are furnished.

Lead thread or wood cobs are available.

Hubbard point type brackets listed were designed specifically for use with this system. The purchaser of Hubbard brackets is assured a license permitting the transposing of wires as covered by the above patent.

If further details are desired, communicate with the nearest Hubbard factory office.

Cat. No.	Stock No.	Description	*Approx. Ship. Wt. Lb. per 100
9272LT	(894392)	Right Hand Bracket, Lead Thread	900
9273LT	(894393)	Left Hand Bracket, Lead Thread	900
9272	(894390)	Right Hand Bracket, Wood Cob	800
9273	(894391)	Left Hand Bracket, Wood Cob	800

\*Including bolts.

## HUBBARD STANDARD TRANSPOSITION BRACKETS

Hot Galvanized



These transposition brackets have a 3/8" hole for a wood screw (shown in the No. 9251 illustrated) and holes for a 3/8" carriage bolt.

All are fitted for pins having a 1/2" diameter short shank. Pins and carriage bolts are not included. These items are shown on other pages.

Cat. No.	Stock No.	Steel Size Inches	Crossarm Size Inches	Ship. Wt. Lb. per 100
9249	(891549)	1 1/4 x 5/16	2 3/4 x 3 3/4	277
†9251	(891550)	1 1/4 x 5/16	3 1/4 x 4 1/4	284

†A.T.&T. Co. Std.

## HUBBARD PRESSED STEEL POLE BRACKETS

Hot Galvanized

Made with a curved back for pole mounting. Especially desirable for long span telephone and signal work. Made from No. 12 ga. steel. Equipped with Peirce 1-inch threads.



Cat. No.	Stock No.	Steel Size	Dimensions—Inches Extension Mount. from Pole Holes	Approx. Ship. Wt. Lb. per 100
20137	(891540)	12 Ga.	4 1/2 7/16	118

## HUBBARD TANDEM TRANSPOSITION BRACKETS

Hot Galvanized

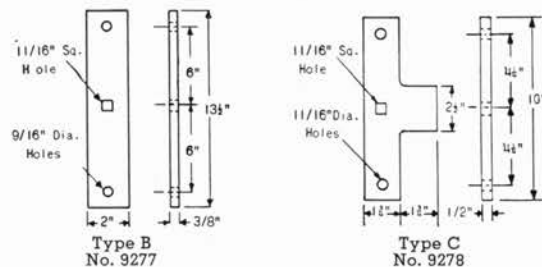

### Type B

For use on Straight Line Transposition. 1 1/16" square hole is for crossarm mounting.

Takes No. 8010 Pin. Made from 2 1/2 x 3/8" flat steel.

Weight—280 pounds per 100 pieces.

Catalog No. 9277 Stock No. (894713)

### Type C

For Transposition at corners. The bracket lug is placed in the direction of the line strain and affords a greater bearing surface. 1 1/16" square hole is for crossarm mounting.

Take No. 8015 pin. Made from 1/2" flat steel.

Weight—300 pounds per 100 pieces.

Catalog No. 9278 Stock No. (894714)

**TRANSPPOSITION BRACKETS**  
Hot Galvanized

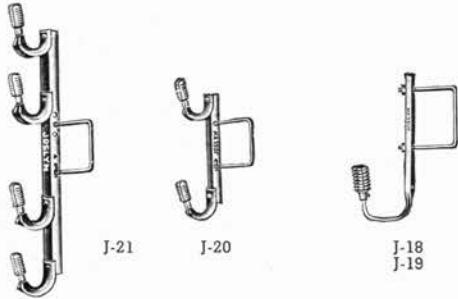

Brackets Nos. J18, J19, J20 and J21, are furnished with "U" bolts for 3/4 x 4/4-inch cross arms unless otherwise specified. Bracket No. J25 is mounted with one 3/8-inch bolt. The sharp prong drives into the wood and prevents rotation.

All brackets have Joslyn Pressed Steel Threads for insulators with 1-inch pin holes.

Cat. No.	Stock No.	No. of Wires	Spacing Inches	Extension In.	Size Points	Stock Back In.	Wt. Lb. per 100
J18	(891545)	1	---	3 7/8	---	3/4	104
J19	(891546)	1	---	3 7/8	---	1	148
J20	(891547)	2	10	3 1/2	No. 12	1	206
J21	(891548)	4	6 1/2 x 10	3 1/2	No. 12	1 1/4	435

**NO. 152 POLE BRACKET**

Recommended for heavy work, such as electric railway feeders and where greater extension from pole is desired.

Channel size, 2 1/16 x 1 1/4 inches x 9 gage. Extension, 5 inches. Mounting holes size, 1 1/16 inch.

Approximate shipping weight per 100, 212 pounds.

Stock No. (891541)



No. 152

**HUBBARD ONE PIECE TRANSPPOSITION BRACKETS**

Hot Galvanized

No. 9260 and No. 9261 are similar to bracket No. 9251 except that the end is turned up and fitted with a 1-inch wood cob. Nos. 9260 and 9261 are single point brackets made from 1 1/4" x 5 1/16" flat steel. No. 9260 is for 3" x 4" arms; No. 9261 is for 3 1/4" x 4 1/4" arms. The sturdy No. 9262, made from 1 1/2" x 3/8" steel, is mounted on any size arm by 1/2" Machine Bolts. Equipped with standard one inch wood cobs for insulator mounting.

Catalog No.	9260	9261	9262
Stock No.	(894710)	(894711)	(894712)
No. of points..	1	1	3
Steel Size . . .	1 1/4 x 5 1/16	1 1/4 x 5 1/16	1 1/2 x 3/8
Crossarm Size.	3x4	3 1/4 x 4 1/4	All Sizes
Ship Wt. Lb. per 100 Pcs.	341	346	918



No. 9262

**PEIRCE PRESSED STEEL CORNER BRACKETS**

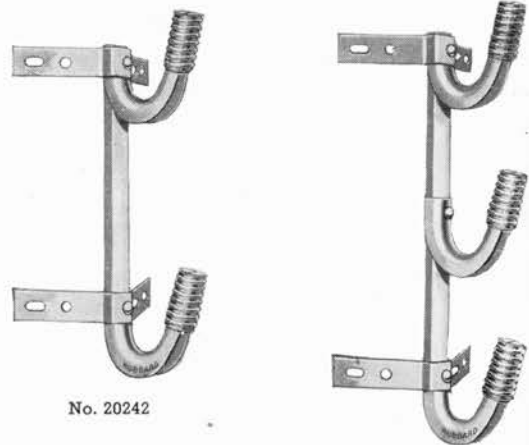

No. 20242

No. 20342



No. 20150

For stringing wires around corners of buildings. May be used for telephone or electric light work. Made of pressed steel, hot galvanized. Lead threads on bracket points.

Cat. No.	Stock No.	Extension Inches	Holes Inches	Spacing Inches	Wt. Lb. per 100
20150	(891542)	3 1/2	1 1/32	---	88
20242	(891543)	3 3/4	1 1/32	9	165
20342	(891544)	3 3/4	1 1/32	6 1/2	297

**NO. 8902 CORNER CABLE SUSPENSION CLAMPS**

Hot Galvanized

For power or communication cable messengers. Used for heavy strains at corners where the included angle of the messenger is approximately 110° or over up to 180°.

It is used with the curved ends pointing toward the pole when the pull is toward the pole and with the curved ends away from the pole when the pull is away.

Used on 6000 and 10000-pound strand with the cable groove of the clamp below the pole bolt and on 16000-pound strand with the groove above the pole bolt. A reinforcing strap is recommended when 16000-pound strand is used. Clamp is drop forged from high carbon steel.

Three-bolt type. Overall length, 7 inches. Mounting hole diameter, 1 3/32 inches. Strand size, 1/4 to 7/16 inch inclusive.

Shipping weight per 100, 375 pounds.

Catalog No. 8902 Stock No. (894473)

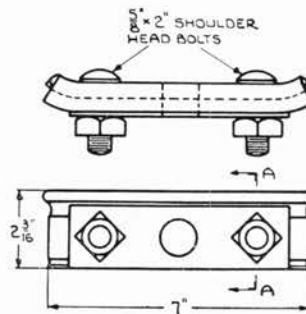

## WESTERN UNION OR SIGNAL PINS

### Hot Galvanized

For use with standard insulators having 1-inch pin holes.

Furnished with best grade, air dried oak cobs, boiled in paraffine, accurately gaged to a uniform size. Pins are made of high carbon steel, with clean threads and square nuts.



No. 8000

### Long Shank Pins

#### For Wood Cross Arms

Cat. No.	Stock No.	Diam. In.	Length, In. Above Shoulder	Length, In. Below Shoulder	Approx. Wt. Lb. 100 Pcs.
+8000	(891298)	1/2	4 1/4	5	80
**+8005	(891299)	5/8	4 1/4	5	114

### Lag Screw Pins

#### For Wood Arms and Poles

Cat. No.	Stock No.	Diam. In.	Length, In. Above Shoulder	Length, In. Below Shoulder	Approx. Wt. Lb. 100 Pcs.
8006	(891300)	1/2	4 1/4	3	56
8007	(891301)	5/8	4 1/4	3	90

### Short Shank Pins

#### For Steel Cross Arms, Transposition Brackets and Break Irons

Cat. No.	Stock No.	Diam. In.	Length, In. Above Shoulder	Length, In. Below Shoulder	Approx. Wt. Lb. 100 Pcs.
**+8010	(891302)	1/2	4 1/4	1	50
**+8015	(891303)	5/8	4 1/4	1	76
+8015-A	(891304)	5/8	4 1/4	1 3/8	93

#### With Long Cob for Transposition Insulators

Cat. No.	Stock No.	Diam. In.	Length, In. Above Shoulder	Length, In. Below Shoulder	Approx. Wt. Lb. 100 Pcs.
*8011	(891305)	1/2	5	1	53
8016	(891306)	5/8	5	1	91

\*A.T.&T. Co. Std. +Western Union Std. #A.R.A. Std.



No. 8010

## WOOD TOP PINS WITH STEEL BOLTS

### Bolts Hot Galvanized

Made of properly seasoned wood tops, thoroughly impregnated with paraffine. Head of solid steel bolt is sunk in pin top to eliminate pressure against insulator.

### For 1-Inch Insulator Pin Hole

Diameter of top of Wood Top, 1 inch; Diameter of steel bolt, 1/2 inch.

Cat. No.	Stock No.	Wood Top, In. Diam. Bottom	Wood Top, In. Lgth.	Bolt, In. Lgth.	Ap- prox. Below Ship. Wood Wt. Lb. Top 100 Pcs.
8064	(891307)	1 13/16	4	9	5 78
8070	(891308)	1 7/8	4 1/2	5 1/2	1 55
8071	(891309)	2 1/4	5 1/4	6 1/2	1 1/4 71
8074	(891310)	1 7/8	4 1/2	9 1/2	5 79
8075	(891311)	2 1/4	5 1/4	10 1/2	5 1/4 92
8076	(891312)	2 1/4	5 1/4	11 1/2	6 1/4 103



No. 8078

### For 1 3/8-Inch Insulator Pin Hole

Diameter of top of Wood Top, 1 3/8 inches; Diameter of steel bolt, 5/8 inch.

Cat. No.	Stock No.	Wood Top, In. Diam. Bottom	Wood Top, In. Lgth.	Bolt, In. Lgth.	Ap- prox. Below Ship. Wood Wt. Lb. Top 100 Pcs.
8072	(891313)	2 1/4	4 1/2	5 1/2	1 100
8073	(891314)	2 1/4	5 1/4	6 1/2	1 1/4 104
8077	(891315)	2 1/4	4 1/2	9 1/2	5 134
8078	(891316)	2 1/4	4 1/2	10 1/2	6 142
8079	(891317)	2 1/4	5 1/4	10 1/2	5 1/4 149
8080	(891318)	2 1/4	6 1/2	12 1/2	6 186
8081	(891319)	2 1/2	8	14	6 225
8082	(891320)	2 3/4	9	16	7 250

## NO. 9035 POLE BALCONIES

### Hot Galvanized

The frame, braces and guard rails of this balcony are made of open hearth steel, galvanized by the hot-dip process.

The wooden platform is made of thoroughly seasoned oak, painted with two coats of standard green pole paint.

The railing fastens to a telephone terminal box. Used for convenience and comfort in telephone terminal box work and serve as switching platforms with the power companies.

Upright braces are 1 1/2 x 1 1/2 x 3/16-inch steel, the platform supports 1 3/4 x 1 3/4 x 3/16-inch angle steel, and the guard rail of 1/4 x 1 1/4-inch flat steel.

Includes all bolts for fastening parts together, but not bolts for attaching to pole.

Size of seat, 14 1/4 x 29 3/4 inches.

Shipping weight per 100, 6300 pounds.

Stock No. (891850)

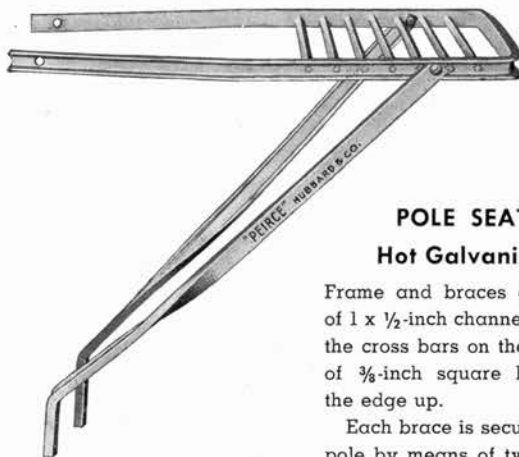

## POLE SEATS

### Hot Galvanized

Frame and braces are made of 1 x 1/2-inch channel iron and the cross bars on the seat are of 3/8-inch square bars with the edge up.

Each brace is secured to the pole by means of two 1/2 x 1-inch lag screws and the frame by means of 9/16 or 1/2-inch lag screws. Designed to fit a 10-

inch diameter pole, but may be fitted to 8 to 12-inch diameter poles.

Catalog No.	755	757
Stock No.	(891851)	(891852)
Size Platform	inches 13 7/8 x 12	12 x 11
Extension from Center of Pole	inches 2 1/2	2 1/4
Weight, Each	pounds 14	12.6

**STROMBERG-CARLSON**

# Poles, Cross Arms, Brackets

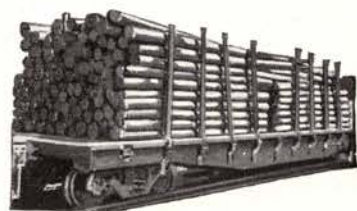
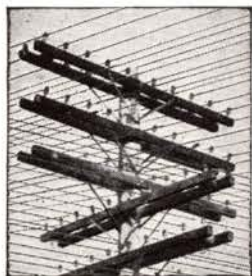

**Poles of creosoted yellow pine, and of red or white cedar with various preservative treatments; cross arms of Douglas fir; locust wood pins and brackets of thoroughly seasoned oak.**

CONTENTS  
SECTION N

**POLES, CROSS ARMS, BRACKETS**

---

	Page
Telephone Poles .....	3n
Specifications for Poles .....	4n
Cross Arms .....	5n
Wood Pins .....	5n
Wood Brackets .....	5n
Transposition Wood Pins .....	6n
Corner Pins .....	6n
Wood Preservatives .....	6n
Clip Washers .....	6n
Bracket Straps .....	6n

---

TELEPHONE POLES

Creosoted Southern Yellow Pine—Western Red Cedar—Northern White Cedar



Creosoted Southern Yellow Pine Poles have within recent years become as popular in the telephone field as the cedars. This timber is stronger than the cedars and consequently the poles need not be so large to give a required strength.

Inasmuch as yellow pine is perishable without preservative treatment it is furnished only after treatment full length under pressure with the finest and cleanest obtainable Creosote Oil, a pure distillate of coal tar. This treatment, it is generally believed, when applied properly to a pine pole that is in perfect condition, will protect the timber for a life in the line upward of thirty years.

In most sections of the country the Creosoted Yellow Pine Pole will figure out being the lowest cost pole obtainable, on an annual cost basis if not actually in first cost.

Northern White and Western Red Cedar Poles are probably in more general use in the independent telephone field today than any other timber. The natural durability of these timbers makes for long life even untreated and by adding open tank butt treatment at very little first cost that natural life in the line can be materially extended. The weight of the cedars is less than yellow pine, which to some users is an advantage in handling, transporting and construction. Other differences between the cedars and yellow pine considered by some users as advantages: Greater taper resulting in larger ground line circumference and consequent greater ground friction when set,

softer texture of the wood to facilitate climbing, lack of creosote treatment in the section above ground to insure against complaints in regard to leaching and to permit painting.

Northern White Cedar Poles can be "Penta" treated to insure maximum protection against decay and termites. A toxic organic chemical compound, many times more powerful and lasting than other preservatives in common use is carried into the wood structure itself. This preservative is non-corrosive, does not affect hardware, or insulation qualities of the pole. Treated poles may be readily handled without any unusual care, as washing with soap and water will remove every trace from the hands.

The Stromberg-Carlson organization feels that both the Pine and Cedar Timbers and in some cases other timbers will provide entirely satisfactory poles. Each kind of timber has its particular qualifications and for some users one may be better suited, while for others the opposite may be true. We have arrangements with the leading producers and treaters of all species, insuring an adequate supply available.

In ordering poles please be as specific as possible in regard to the specifications concerning both grade and size as well as treatment. Creosoted Pine Pole prices always include framing (roofing, gabling and boring for through bolts) in accord with customers' instructions so orders should be accompanied with a sketch or other complete description.

STROMBERG-CARLSON

## TABLES OF POLE DIMENSIONS AND WEIGHTS

American Standards Association  
(A.S.A.) Specifications

### CREOSOTED SOUTHERN YELLOW PINE POLES Class

Length Feet	Minimum Top Circumference, Inches											
	5		6		7		8		9		10	
	19	17	15	18	15	12	18	15	12	15	12	
	Minimum Circumfer- ence In.	Weight Pounds Each	Minimum Circumfer- ence In.	Weight Pounds Each	Minimum Circumfer- ence In.	Weight Pounds Each	*Minimum Circumfer- ence In.	Weight Pounds Each	*Minimum Circumfer- ence In.	Weight Pounds Each	*Minimum Circumfer- ence In.	Weight Pounds Each
16	21.5	234	19.5	202	18.0	165	---	188	---	138	---	110
18	22.5	275	21.0	234	19.0	188	---	211	---	151	---	133
20	23.5	330	22.0	284	20.0	234	---	261	---	202	---	161
22	24.5	398	23.0	339	21.0	284	---	307	---	234	---	188
25	26.0	491	24.0	422	22.0	334	---	389	---	289	---	234
30	28.0	660	26.0	550	24.0	454	---	513	---	371	---	---
35	30.0	862	27.5	743	25.5	646	---	697	---	---	---	---
40	31.5	1059	29.0	921	27.0	807	---	---	---	---	---	---
45	33.0	1274	30.5	1114	28.5	976	---	---	---	---	---	---

\*No butt requirements

### WESTERN RED CEDAR POLES Class

Length Feet	Minimum Top Circumference, Inches											
	5		6		7		8		9		10	
	19	17	15	18	15	12	18	15	12	15	12	
	Minimum Circumfer- ence In.	Weight Pounds Each	Minimum Circumfer- ence In.	Weight Pounds Each	Minimum Circumfer- ence In.	Weight Pounds Each	*Minimum Circumfer- ence In.	Weight Pounds Each	*Minimum Circumfer- ence In.	Weight Pounds Each	*Minimum Circumfer- ence In.	Weight Pounds Each
20	25.5	240	23.5	180	22.0	160	---	160	---	120	---	90
25	28.5	320	26.0	255	24.5	200	---	205	---	180	---	120
30	30.5	400	28.5	335	26.5	280	---	295	---	225	---	---
35	32.5	520	30.5	450	28.0	375	---	405	---	---	---	---
40	34.5	640	32.0	560	---	---	---	---	---	---	---	---
45	36.5	800	---	---	---	---	---	---	---	---	---	---

\*No butt requirements

### NORTHERN WHITE CEDAR POLES Class

Length Feet	Minimum Top Circumference, Inches											
	5		6		7		8		9		10	
	19	17	15	18	15	12	18	15	12	15	12	
	Minimum Circumfer- ence In.	Weight Pounds Each	Minimum Circumfer- ence In.	Weight Pounds Each	Minimum Circumfer- ence In.	Weight Pounds Each	*Minimum Circumfer- ence In.	Weight Pounds Each	*Minimum Circumfer- ence In.	Weight Pounds Each	*Minimum Circumfer- ence In.	Weight Pounds Each
16	26.0	230	24.0	190	22.0	135	---	135	---	105	---	85
18	28.0	300	25.5	230	23.5	190	---	190	---	130	---	100
20	29.0	300	27.0	230	25.0	190	---	190	---	130	---	100
22	30.5	420	28.0	300	26.0	225	---	225	---	200	---	150
25	32.5	420	30.0	300	28.0	250	---	250	---	200	---	150
30	35.5	520	33.0	420	30.5	350	---	350	---	275	---	---
35	38.0	720	35.0	510	32.5	450	---	---	---	---	---	---
40	40.0	790	37.0	740	---	---	---	---	---	---	---	---
45	42.0	1080	---	---	---	---	---	---	---	---	---	---

\*No butt requirements

Minimum circumferences listed are measured at 6 feet from butt.

#### STOCK NUMBERS

For all Yellow Pine Poles (894844)  
For all Red Cedar Poles (894845)  
For all White Cedar Poles (894846)

Give complete specifications as to Class, Circumference and Length; also instructions for preservative treatment.

The purchasing of poles on other than A.S.A. specifications is rapidly becoming an obsolete practice. As long as the other specifications are in use, however, we will be in position to intelligently handle inquiries and orders relating to them.

The figures in the tables are given only with reference to the more typical telephone pole sizes.

For other sizes please make special inquiry.

**STANDARD TELEPHONE CROSSARMS**

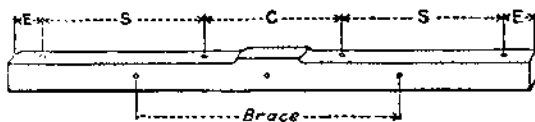

**DOUGLAS FIR CROSSARMS**

Manufactured from old growth Douglas yellow fir obtained from virgin forest in the northwest. Fir, because of its durability and light weight, compared with its strength, has been almost universally adopted for crossarm purposes by the telephone companies.

All arms are Kiln or air dried so as to insure the uniformity of the seasoning. Modern machine equipment is employed in the surfacing of the arms and in the boring of the pin holes.

**Electric Light Arms**

Size arm, 3 1/4 x 4 1/4 inches. Size pin holes, 1 7/32 inches. Size center bolt hole, 5/8 inches.

Lgth. Feet	No. Pin Holes	Stock No.	Pin Hole Center	Spacing Sides	Spacing Ends	*Brace Bolt per 100 Spacing	Wt. Lb. per 100
3	2	(891140)	28	---	4	25	1062
4	4	(891141)	16	12	4	28	1416
5	4	(891142)	18	17	4	28	1770
6	4	(891143)	22	21	4	32	2124
6	6	(891144)	16	12	4	32	2124
8	6	(891145)	18	17 1/2	4	32	2832
8	8	(891146)	16	12	4	32	2832
8 1/2	10	(891147)	16	9 3/4	4	32	3009
10	8	(891148)	17 1/2	15 3/4	4	42	3540
10	10	(891149)	16	12	4	42	3540

**Pony Telephone Arms**

Size arm, 2 3/4 x 3 3/4 inches. Size pin holes, 1 7/32 inches. Size center bolt hole, 5/8 inch.

Lgth. In.	No. Pin Holes	Stock No.	Pin Hole Center	Spacing Sides	Spacing Ends	*Brace Bolt per 100 Spacing	Wt. Lb. per 100
24	2	(891150)	17	---	3 1/2	---	540
30	2	(891151)	23	---	3 1/2	---	675
36	2	(891152)	29	---	3 1/2	25	810
42	4	(891153)	16	9 1/2	3 1/2	28	945
62	6	(891154)	16	9 3/4	3 1/2	28	1395
82	8	(891155)	16	9 3/4	3 3/4	28	1845
102	10	(891156)	16	9 3/4	4	28	2295
120	12	(891157)	16	9 3/4	3 7/8	28	2700

\*All arms are bored with 3/8 inch brace bolt holes unless otherwise specified

**CREOSOTED YELLOW PINE CROSSARMS**

These arms have become increasing popular in recent years and are being used extensively in some localities. Sound southern yellow pine is close and straight grained. Defects impairing strength are strictly prohibited.

Arms are thoroughly seasoned and are pressure treated by the Rueping Empty Cell Process to final retention of eight pounds per cubic foot of wood with No. 1 grade pure coal tar creosote oil.

**Electric Light Arms**

Size arm, 3 1/4 x 4 1/4 inches. Size pin holes 1 7/32 inches. Size center bolt hole, 5/8 inches.

Lgth. Feet	No. Pin Holes	Stock No.	Pin Hole Center	Spacing Sides	Spacing Ends	*Brace Bolt per Arm Spacing	Wt. Lb.
3	2	(891158)	28	---	4	25	15
4	4	(891159)	16	12	4	28	20
5	4	(891160)	18	17	4	28	26
6	4	(891161)	22	21	4	32	31
6	6	(891162)	16	12	4	32	31
8	6	(891163)	18	17 1/2	4	32	41
8	8	(891164)	16	12	4	32	41
8 1/2	10	(891165)	16	9 3/4	4	32	43
10	8	(891166)	17 1/2	15 3/4	4	42	51
10	10	(891166)	16	12	4	42	51
10	12	(891168)	16	9 3/4	3 7/8	42	51

**Pony Telephone Arms**

Size arm, 2 3/4 x 3 3/4 inches. Size pin holes, 1 7/32 inches. Size center bolt hole, 5/8 inch.

Lgth. In.	No. Pin Holes	Stock No.	Pin Hole Center	Spacing Sides	Spacing Ends	*Brace Bolt per Arm Spacing	Wt. Lb.
24	2	(891169)	17	---	3 1/2	---	8
30	2	(891170)	23	---	3 1/2	---	10
36	2	(891171)	29	---	3 1/2	25	12
42	4	(891172)	16	9 1/2	3 1/2	28	13
62	6	(891173)	16	9 3/4	3 1/2	28	20
82	8	(891174)	16	9 3/4	3 3/4	28	26
102	10	(891175)	16	9 3/4	4	28	32
120	12	(891176)	16	9 3/4	3 7/8	28	38

\*All arms are bored with 3/8 inch brace bolt holes unless otherwise specified.

NOTE: Length of Brace corresponding to different lengths of crossarms:

**Electric Light Arms**

3 foot arm	20 inch brace
4, 5 foot arm	22 inch brace
6, 8, 8 1/2 foot arm	24 inch brace
10 foot arm	30 inch brace

**Pony Telephone Arms**

36 inch arm	20 inch brace
All Larger Sizes	22 inch brace



**STANDARD WOOD PINS**

Made of locust wood. Is hard, close-grained wood, impenetrable to moisture and practically impervious to decay. Especially well suited for making wood insulator pins where accurate turning and freedom from shrinking or warping are primary considerations.

All pins are shipped in heavy burlap bags.

Size Pin Inches	Stock No.	Size Top Inches	No. in Std. Pkg	Wt. Lb. per 1000
1 1/4 x 8	(891293)	1	250	325
1 1/2 x 9	(891294)	1	250	480



**WOOD BRACKETS**

These brackets made of oak are fastened to pole or wail by spikes.

Holes in brackets are 5/16-inch diameter.

Brackets are securely wired in bundles of 20 or 25 each.

Furnished plain or creosote-dipped.

Type	Stock No.	Size Inches	Std. Pkg.	Wt. Lb. per 1000
4	(891281)	1 1/2 x 2 x 10	250	600
L.D.	(891282)	1 3/4 x 2 x 12	250	800
W.U.	(891283)	2 x 2 3/8 x 12	250	1000
New W.U.	(891284)	2 x 2 3/4 x 12	250	1150



## WOOD POLE STEPS

Made from oak, seasoned and dried.  
 5/16 holes for spikes are drilled.  
 Wired in bundles of 20 or 25 for shipment.  
 Catalog No. J-2662  
 Stock No. (891269)  
 Size Inches 1 1/4 x 2 3/8 x 7  
 Weight Pounds per 1000 700

## TRANSPPOSITION WOOD PINS

Transposition pins, similar to standard wood pins, have an extra long thread for use with transposition insulators.  
 Made of locust, with standard 1-inch threads.

Size Pin Inches	Stock No.	No. in Std. Pkg.	Wt. Lb. per 1000
1 1/4 x 9	(891295)	250	400



## CORNER PINS

Reinforced with 3/8-inch bolt which extends through entire length of the pin. An extra large washer is provided so that the nut may be tightened and the pin securely fastened in place.  
 Locust wood.

Cat. No.	Stock No.	Description	Wt. Lb. per 100
1784	(891296)	1 1/4 x 8 Corner	625
1785	(891297)	1 1/4 x 9 Corner	775

## CARBOLINEUM

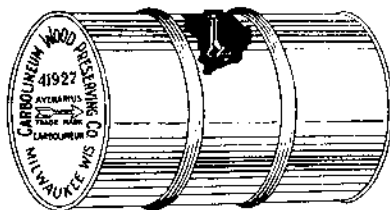

"Avenarius Carbolineum", wood preservative, is four times richer in wood preserving elements than average creosote oils. Will prevent premature rot and decay and will from double to triple the life of poles, posts, braces, cross arms, etc. Termites will not attack "Carbolineum" treated wood.

Liquid and usable at all times. No bleeding or oozing in hot weather; no heating, pressure, special equipment or skilled labor is necessary. Apply at site simply by brush, spray or quick dip. One gallon treats 3 to 6 butts depending on size of poles or 100 to 200 square feet of surface. Stock No. (891279)

## C-A WOOD PRESERVER (Carbolineum America)

Pole butts treated with this product have lasted 25 years.  
 To retard rot on erected poles, dirt is dug away from the ground line and C-A wood preserver (CARBOLINEUM AMERICA) is sprayed on the poles. Dirt is replaced about 24 hours later.  
 The product is so efficient that if 1/3 of it is mixed with 2/3's fuel oil or used crank case oil, the mixture is fully equal to the highest grade of creosote oil. Stock No. (891280)

## HUBBARD BRACKET STRAPS AND CLIP WASHERS Hot Galvanized

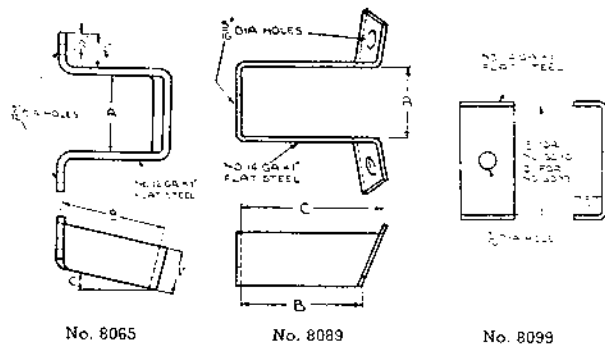

Two bracket straps, top and bottom, are used on each wood bracket. A. T. & T. Standard.

No. 8089 top clip washer and No. 8090 bottom clip washer are to be used with Graybar Standard No. 1 Wood Bracket.

No. 8098 top clip washer and No. 8099 bottom clip washer are to be used with Graybar Standard No. 2 Wood Bracket.

Cat. No.	Stock No.	Description	Dimensions			Ship. Wt. per C
			A In.	B In.	C	
8065	(891285)	Low. Brkt. W. U.	1 5/16	15/16	19°	16
8066	(891286)	Top Brkt. W. U.	1 5/16	27/16	19°	25
8067	(891287)	Top Brkt. L. D.	1 3/4	2	15°	22
8068	(891288)	Low. Brkt. L. D.	1 3/4	7/8	15°	16
8089	(891289)	Top Washer	1 1/2	1 11/16	1 5/16	17
8090	(891290)	Low. Washer	1 1/2	-	-	6
8098	(891291)	Top Washer	2	2	2 1/4	20
8099	(891292)	Low. Washer	2	-	-	8

## JOSLYN BRACKET STRAPS

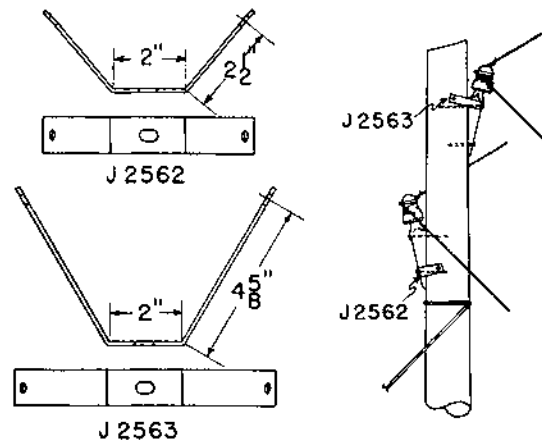

Joslyn bracket straps are used to reinforce the wood bracket when new types of high strength wire are used. Longer spans are used and therefore the strain on the fastenings is greatly increased, especially on angles. The bottom strap is used on an outside bracket and the top strap on an inside bracket, as illustrated.

Mounting holes are 5/16 inch. The straps are made of 1-inch x No. 14 gage steel, to fit brackets 2 inches wide.

Cat. No.	Stock No.	Description	Wt. Lb. per 100
J2562	(894663)	Bottom	18
J2563	(894664)	Top	28

**STROMBERG-CARLSON**

# Cable and Cable Supplies

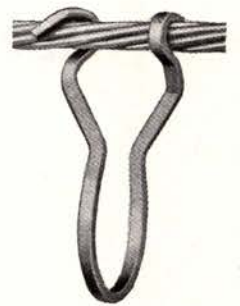

High quality telephone cable; clay and fibre conduit; cable spinners and hangers; solder melting pots and blow torches.

CONTENTS  
SECTION P

**CABLE AND CABLE SUPPLIES**

---

	Page
Insulated Telephone Cable .....	3p
Convenience System Cable .....	4p
Inter-Communicating Cable .....	4p
Switchboard Cable .....	5p
Switchboard Wire .....	6p
Linen Test Boards .....	6p
Roll-a-Reels .....	6p
Conduit Supplies .....	6p
Clay Conduit .....	7p
Reel Jacks .....	8p
Manhole Supplies .....	9p
Cable Cars .....	10p
Cable Spinners .....	11p
Cable Hangers and Clamps .....	13p
Paper and Lead Sleeves .....	16p
Wax, Candles, Pastes .....	16p
Solder and Soldering Supplies .....	18p
Blow Torches and Melting Pots .....	20p

---

**PAPER INSULATED LEAD ENCASED TELEPHONE CABLE**

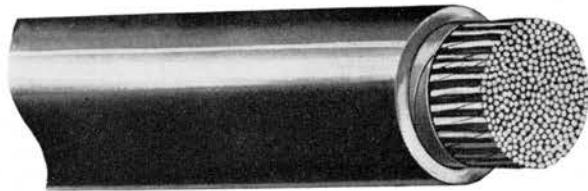

Kennecott telephone cable is regularly made with various electrostatic capacitances and with conductors of Nos. 16, 19, 22, 24, and 26 A.W.G. Each wire is insulated with one or more wraps of manila paper, or paper made from clear rope stock with suitable proportions of wood pulp or cotton rag stock added. The paper is wound loosely, in helical form, around the wire.

After insulation of the conductors they are twisted together to form pairs, each wire of a pair being wrapped with paper of a different color for tracing purposes. The length of lay of the twisted pair varies from two to five and one-half inches.

The twisted pairs are cabled together in layers, each layer being one pair thick. Alternate layers are cabled in opposite directions. The completed cable core is taped over with paper.

The cable is then treated under controlled high temperature and vacuum to remove the moisture from the cable without causing deterioration of the paper insulation.

The cable is then sheathed with lead containing one per cent antimony. The lead-antimony sheath is usually used to give additional stiffness to the sheath and to prevent crystallization of the lead under continuous vibration. Efficiency of transmission depends upon the resistance of the conductors, the electrostatic capacitance and, to a limited extent, on the insulation resistance.

**CONDUCTOR RESISTANCE**—Except for purposes of long distance transmission, where a lower conductor resistance may be necessary, cables are usually built of Nos. 19, 22, 24, or 26 A.W.G. wires. The resistance of these wires—approximately 42.5 ohms, 85 ohms, 136 ohms, and 215 ohms per mile respectively at 20° C—is increased by twisting into pairs and by cabling, but as the increase is not constant the maximum resistance for any wire in the cable is usually specified.

**ELECTROSTATIC CAPACITANCE**—The electrostatic capacitance is specified in microfarads per mile at a given temperature and is expressed as "mutual capacitance" or "grounded capacitance." By "mutual capacitance" is meant the capacitance between one wire of a pair and its mate, the measurement being made while all the other wires of the cable are connected to the sheath and to ground. By "grounded capacitance" is meant the capacitance between one wire and the balance of the wires and the sheath of the cable. The grounded capacitance of a wire in a cable is approximately one and one-half times the mutual capacitance of the pair of which that wire is a part. The lower the capacitance of a cable, the greater the separation of the conductors, i.e., for two cables with the same number of conductors of the same size, the cable with the lower capacitance will have the larger diameter under the lead.

**INSULATION RESISTANCE**—The effect of insulation resistance under actual working conditions is not definitely known owing to the high frequencies employed. The usual practice is to specify a minimum of 500 megohm miles, which is considered sufficiently high to prevent appreciable leakage.

**TRANSMISSION LOSS**

In Dbs. per loop mile for various types of telephone cables is as follows:

Wire Size	Insulation	Mutual Capacitance Mfds. per mile	Transmission loss dbs. per mile at		
			800 cycles	900 cycles	1000 cycles
24	Single Paper	.09	2.16	2.29	2.41
22	Double Paper	.08	1.63	1.72	1.82
22	Single Paper	.09	1.72	1.82	1.92
19	Double Paper	.08	1.15	1.22	1.28
19	Single Paper	.09	1.22	1.29	1.36

**CONDUCTORS**

Each conductor shall be solid wire of commercially pure annealed copper, smoothly drawn, cylindrical, uniform in quality and resistance and free from scale and other defects.

**INSULATION**

Each conductor shall be insulated with a single or double wrap of paper, as required by the type of cable, applied helically with an overlap. When two wraps are used, they are applied in reverse directions.

**No. 24 S.P.W. Lead Covered Cable, .09 M.C.**

No. of Pairs	Stock No.	Lead Thk.	O.D.	Net Wt. M. Ft.	Reel Length	Approx. Ship. Wt.
6	(890323)	.060	.31	261	3,500	305
11	(890324)	.061	.35	320	3,500	364
16	(890325)	.062	.39	380	3,500	441
26	(890326)	.063	.47	487	4,500	577
51	(890327)	.066	.59	710	4,200	818
76	(890328)	.069	.70	923	3,000	1,074
101	(890329)	.071	.78	1,110	3,000	1,377
152	(890330)	.074	.92	1,453	2,800	1,728
202	(890331)	.077	1.04	1,792	2,200	2,142
303	(890332)	.082	1.24	2,423	1,600	2,904
404	(890333)	.086	1.41	3,019	1,400	3,628
505	(890334)	.089	1.57	3,598	1,300	4,253
606	(890335)	.093	1.71	4,188	1,100	4,963
909	(890336)	.102	2.05	5,864	900	7,084
1212	(890337)	.109	2.35	7,474	650	9,163

**No. 22 S.P.W. Lead Covered Cable, .09 M.C.**

No. of Pairs	Stock No.	Lead Thk.	O.D.	Net Wt. M. Ft.	Reel Length	Approx. Ship. Wt.
6	(890352)	.061	.37	341	3,500	402
11	(890353)	.063	.44	437	3,500	498
16	(890354)	.064	.47	490	3,500	551
26	(890355)	.066	.56	646	3,500	762
51	(890356)	.070	.73	973	3,000	1,124
76	(890357)	.073	.86	1,262	2,500	1,579
101	(890358)	.076	.97	1,549	2,500	1,857
152	(890359)	.080	1.15	2,057	1,600	2,538
202	(890360)	.084	1.30	2,557	1,600	3,089
253	(890361)	.087	1.45	3,044	1,500	3,612
303	(890362)	.090	1.57	3,496	1,400	4,105
404	(890363)	.095	1.79	4,393	1,200	5,308
505	(890364)	.099	1.99	5,262	1,000	6,360
606	(890365)	.104	2.17	6,156	900	7,509

**PAPER INSULATED LEAD ENCASED TELEPHONE CABLE (Cont.)**

**No. 22 D.P.W. Lead Covered Cable, .08 M.C.**

No. of Pairs	Stock No.	Lead Thk.	O.D.	Net Wt. M. Ft.	Reel Length	Approx. Ship. Wt.
6	(890338)	.061	.37	336	3,500	397
11	(890339)	.063	.46	455	3,500	516
16	(890340)	.065	.52	556	3,500	672
26	(890341)	.067	.62	731	3,500	861
51	(890342)	.072	.82	1,123	3,000	1,379
76	(890343)	.076	.97	1,470	2,500	1,778
101	(890344)	.079	1.11	1,804	2,500	2,145
152	(890345)	.084	1.32	2,413	1,600	2,946
202	(890346)	.088	1.50	2,982	1,600	3,515
253	(890347)	.092	1.66	3,564	1,500	4,296
303	(890348)	.096	1.81	4,132	1,400	5,002
404	(890349)	.102	2.06	5,193	1,200	6,208
505	(890350)	.108	2.30	6,268	1,000	7,486
606	(890351)	.113	2.50	7,289	900	8,642

**No. 19 S.P.W. Lead Covered Cable, .09 M.C.**

No. of Pairs	Stock No.	Lead Thk.	O.D.	Net Wt. M. Ft.	Reel Length	Approx. Ship. Wt.
6	(890387)	.063	.43	425	3,500	486
11	(890388)	.065	.52	576	3,500	692
16	(890389)	.067	.59	714	3,500	844
26	(890390)	.070	.72	967	3,000	1,118
51	(890391)	.075	.97	1,513	2,500	1,821
76	(890392)	.080	1.13	2,032	1,800	2,505
101	(890393)	.084	1.29	2,530	1,600	3,063
202	(890394)	.095	1.76	4,347	1,200	5,265
303	(890395)	.104	2.19	6,170	900	7,519

**No. 19 D. P. W. Lead Covered Cable, .08 M.C.**

No. of Pairs	Stock No.	Lead Thk.	O.D.	Net Wt. M. Ft.	Reel Length	Approx. Ship. Wt.
6	(890377)	.063	.47	469	3,500	530
11	(890378)	.066	.57	646	3,500	762
16	(890379)	.068	.66	800	2,500	963
26	(890380)	.071	.80	1,089	2,500	1,271
51	(890381)	.078	1.07	1,734	1,500	2,037
76	(890382)	.083	1.28	2,328	1,500	2,896
101	(890383)	.087	1.44	2,875	1,500	3,443
202	(890384)	.100	1.98	4,974	1,100	6,079
303	(890385)	.110	2.40	6,974	1,000	8,300
404	(890386)	.119	2.75	8,924	700	10,821

**CABLES FOR CONVENIENCE SYSTEMS**

All wires are tinned copper. Moisture-treated external cotton braid (B), lead sheath (L), or plastic (P) over all covering. The lead sheath is recommended in all cases where the cable is subject to mechanical injury. Conductors are No. 22 AWG Pairs and No. 18 AWG Singles.

**Recommended for No. 2-6 Type Systems (No. 2-6, No. 3-5, No. 1-7)**

Code No.	Stock No.	No. of Pairs 22 AWG	No. of Singles 18 AWG	Cover
102-B	(800201)	10	2	Braid
102-L	(800203)	10	2	Lead
102-P	(203155)	10	2	Plastic

**Recommended for No. 2-10 Type Systems (No. 2-10, No. 3-9, No. 1-11)**

Code No.	Stock No.	No. of Pairs 22 AWG	No. of Singles 18 AWG	Cover
103-B	(800202)	12	2	Braid
103-L	(800204)	12	2	Lead
103-P	(203154)	12	2	Plastic

See Section D in the first half of this catalog for the Convenience Systems with which this cable is used.

**INTER-COMMUNICATING CABLES**

There are two general types of cable; care should be taken to order the proper cable for a desired purpose. These types are:

1. Interior Cable with outside braiding treated with a gray flame proof paint type saturant. This type of cable is recommended for use only in dry places.
2. Outside Cable with an outside covering of plastic material. This cable should be used where there is a possibility of moisture being present in the vicinity of a cable run.

The conductors of these types of cable are solid copper wires and are provided with plastic insulation which is colored in such a way that each single conductor and each pair of wires can be easily identified. The conductors, single and/or pairs are then bunched together to form a cable of maximum flexibility.

In the case of the interior cable the bunched wires are then covered with a serving of Kraft paper which is further covered with an overall soft cotton braid, saturated with a gray flame proof paint type saturant. In the case of the outside cable, the bunched wires are covered with a soft cotton braid and then further covered with a plastic coating.

**Braid Outside Cover**

Code No.	Stock No.	Replaces Old Code	No. 22 AWG Cond.	Spare	Lb. per 100
1C-112	(45886)	164-B	6 Sg.	2 Wires	5.9
1C-122	(45882)	244-B	8 Pr.	1 Pr.	9.8
1C-134	(45883)	246-B	14 Pr.	1 Pr.	13.3
1C-142	(45884)	248-B	18 Pr.	1 Pr.	15.9
1C-158	(45885)	250-B	26 Pr.	1 Pr.	21.2

**Plastic Outside Cover**

Code No.	Stock No.	Replaces Old Code	No. 22 AWG Cond.	Spare	Lb. per 100
1C-212	(45914)	164-B5	6 Sg.	2 Wires	8.2
1C-222	(45910)	244-B5	8 Pr.	1 Pr.	13.3
1C-234	(45911)	246-B5	14 Pr.	1 Pr.	19.0
1C-258	(45913)	250-B5	26 Pr.	1 Pr.	25.5

All of the cables above have 2 Pairs of No. 18 AWG conductors for talking-ringing circuits.

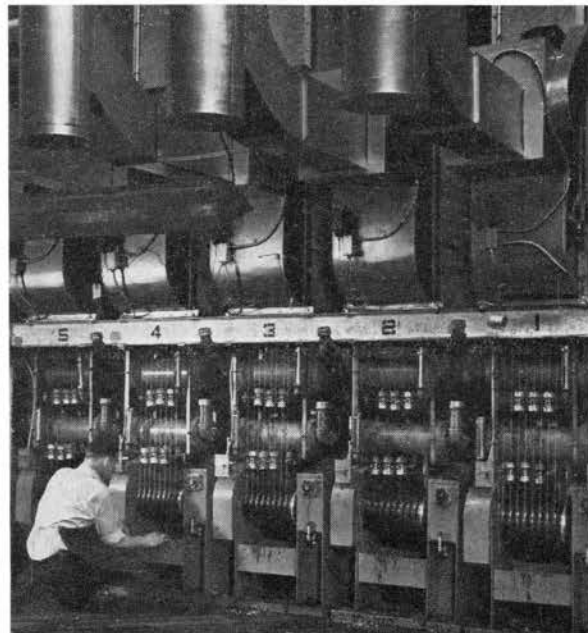

Stromberg-Carlson Lacquer Towers for coating miles of copper wire.

**SWITCHBOARD CABLE**

All standard switchboard cable has tinned copper wires with butyrate tape and single cotton insulation. Cable with braided cover is indicated by the letter B and cable with lead sheath is indicated by the letter L affixed to the code number. Cable having enameled wire is indicated by the letter E affixed to the code number.

All cable from 10 to 50 pairs inclusive, has one spare pair, and 100 pairs of cables has two spare pairs. The 10-triple and 20-triple cable have one spare triple.

		Pairs			
Code No.	Stock No.	No. of Pairs	Approx. Diam. In.	Thick Lead Sheath In.	Wt. Lb per 1000'
71-B	(800164)	10	3/8	---	70
71-L	(800165)	10	27/64	3/64	353
71-BE	(41318)	10	23/64	---	68
66-B	(800157)	20	15/32	---	139
66-L	(800159)	20	35/64	1/16	603
66-BE	(800158)	20	29/64	---	135
66-LE	(200374)	20	35/64	1/16	600
84-B	(800176)	25	9/16	---	182
84-L	(800177)	25	43/64	5/64	733
84-BE	(44328)	25	35/64	---	178
90-B	(800185)	50	5/8	---	328
90-L	(800188)	50	47/64	5/64	1112
90-BE	(800186)	50	19/32	---	320
91-B	(800189)	100	1	---	558
91-L	(800190)	100	1 9/64	3/32	1798
91-BE	(200951)	100	57/64	---	550

**Triplets**

Code No.	Stock No.	No. of Triplets	Approx. Diam. Inches	Wt. Lb. per 1000'
72-B	(800166)	10	7/16	105
72-BE	(42847)	10	27/64	100
65-B	(800155)	20	9/16	206
65-BE	(800156)	20	35/64	201
76-B	(800168)	20	11/16x21/64	324
76-BE	(45287)	20	21/32x19/64	320

**Singles and Triplets**

Code No.	Stock No.	No. of Singles	No. of Triplets	Approx. Diam. In.	Wt. Lb. per 1000'
68-B	(800161)	20	20	21/32	270
68-BE	(800162)	20	20	5/8	267

**No. 18 AWG Gage Cable (Toll)**

		Pairs		
Code No.	Stock No.	No. of Pairs	Approx. Diam. Inches	Wt. Lb. per 1000'
86-B	(800179)	10	7/16	130
86-BE	(41321)	10	3/8	126
85-B	(800178)	20	35/64	212
85-BE	(41320)	20	17/32	122

**Generator Cable**

No. 87-BE cable has butyrate tape cotton over No. 22 AWG enamel wire conductors. No. 88 cable has No. 18 AGW rubber-covered and cotton braided individual conductors.

Code No.	Stock No.	No. of Single Cond.	Wt. Lb. per 1000'	Approx. Diam. Inches
87-BE	(800180)	6	58	5/16
88	(800183)	6	90	5/16



Making a Switchboard Cable in the Stromberg-Carlson plant.

## SWITCHBOARD CABLE (Cont.)

### Switchboard Wire

This wire is used principally for making up hand-formed switchboard and telephone cable forms. It is furnished in standard code colors. Insulation is one serving of cellulose acetate butyrate tape and one cotton either served or braided.

Complete spools contain from 8 to 10 pounds of wire.

#### Served Insulation

Stock No.	AWG	Conductors	Approx. Ft. per Lb.
20262	22	Single	390
20263	22	Duplex	195
20264	22	Triplex	130
20265	22	Quadruplex	97
20274	18	Single	172
20275	18	Duplex	86

#### Braided Insulation

Stock No.	AWG	Conductors	Approx. Ft. per Lb.
20266	22	Single	308
20267	22	Duplex	154
20268	22	Triplex	102
20269	22	Quadruplex	77
20276	18	Single	146
20277	18	Duplex	73

When ordering switchboard wire, specify amount required in pounds or feet, colors desired and whether single or twisted pair wire is required.

## ROLL-A-REEL

Roll-A-Reel is sturdily built to roll reels of electrical wire and cables, steel strand, rope, in fact anything that is dispensed from a reel. The strong ball bearing rollers with the hex ends lock in the end channels and insure the reel rolling on the ball bearing rollers smoothly and without friction. The heavy gauge steel frame gives added strength and rigidity. Yet Roll-A-Reel is light in weight and offers extreme portability.

Roll-A-Reel is available in two sizes: Style A, for single reels up to 28 inches wide or up to 2000 lbs. in weight. Style B, for two reels up to 24 inches in width or up to one 48 inch wide reel. Both styles have simple roller adjustments for extreme reel sizes. Style A, has one simple positive roller lock. Style B, has two locks; one for each front roller. The Style B, provides separate set of rigidly aligned rollers for each side of large reels to compensate for possible variation in their diameter.



Style A: Width 30". Depth 28". Height 3 1/2". Weight 50 lbs. Capacity 2000 lbs. Supports up to one 28" wide reel. Stock No. (894050)



Style B: Width 52". Depth 28". Height 4". Weight 110 lbs. Supports two 24" wide reels or up to one 48" wide reel. Capacity 4000 lbs. Stock No. (894051)

## CABLE CONDUIT

### FIBRE CONDUIT

Fibre Conduit of the Harrington Joint (Tapered Sleeve) Type may be had on special order. This conduit has the advantage of flexibility, a great help in curving around minor obstacles. As a service to its customers, Stromberg-Carlson Company will gladly furnish specification and prices upon request to your nearest representative.

## LINEN TEST BOARDS

For use in tagging out the Conductors in connection with making test splices in cables. Consists of tag-linen strips 1 7/8 inches wide and 10 7/8 inches long having numbered holes and printed in the following sets of numbers:

Stock No.	Numbered	Stock No.	Numbered
(890715)	1-51	(890721)	304-354
(890716)	51-101	(890722)	354-404
(890717)	102-152	(890723)	405-455
(890718)	152-202	(890724)	455-505
(890719)	203-253	(890725)	506-556
(890720)	253-303	(890726)	556-606

## CONDUIT JOINT TAPE

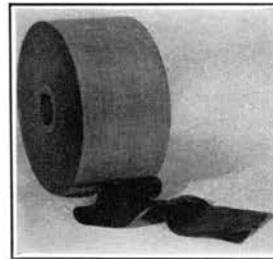

An especially prepared tape is frequently used for wrapping the joints of multiple duct conduit prior to the application of the joint mortar, also occasionally used for wrapping joints of single duct conduit in trench, subway or masonry structures, prior to the pouring of the concrete encasement.

This tape has an adhesive water-proof coating on one side, and is supplied in 4 and 6-inch widths, and put up in rolls of 100 linear yards.

Tape adheres closely and firmly to the glazed surface of the conduit and aids in sealing the joints.

In ordering, specify total number of linear yards required.

Width Inches	Stock No.
4	(891072)
6	(891073)

## NO. 9145 HUBBARD PLAIN DOWEL PINS

### For Clay Conduit



Used in the ends of multiple duct clay conduit for preserving alignment of adjacent sections. Made of 5/16-inch diameter steel with a shoulder in the center. Overall length, 3 3/64 inches. Collar diameter, 5/8 inch.

Shipping Weight, 9 Pounds per 100.

Catalog No. 9145 Stock No. (891085)

**CLAY CONDUIT**

Clay Conduit is manufactured from high grade fine clay, treated at over 2000° F., and salt-glazed to provide a smooth, permanent surface. It is the standard material for underground cable work because of its strength, long life and low cost. A very

complete list of shapes meets all the usual requirements; sizes shown are readily obtainable, while others may be ordered if special applications require them.  
In ordering, specify the shape, bore, and length.



1-Way Round  
3 1/4" x 18" Stock No. (891087)

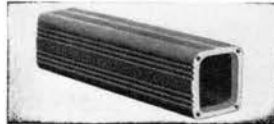

1-Way Square  
3 1/4" x 18" Stock No. (891086)

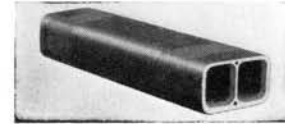

2-Way Square  
3 1/4" x 24" Stock No. (891089)

(Not Illustrated)  
3-Way Square  
3 1/4" x 24" Stock No. (891090)

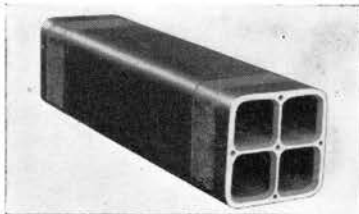

4-Way Square  
3 1/4" x 36" Stock No. (891091)

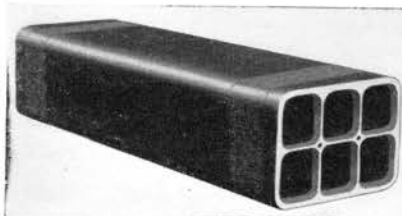

6-Way Square  
3 1/4" x 36" Stock No. (891092)

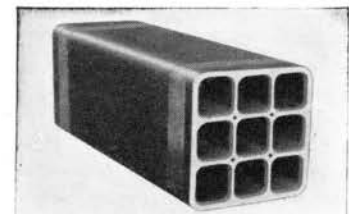

9-Way Square  
3 1/4" x 36" Stock No. (894770)



**CREOSOTED WOOD CONDUIT**

Creosoted Wood Conduit is a duct material with the following characteristics:

1. Tensile Strength
2. Crushing Strength
3. Resistance to Implements
4. Flexibility in handling
5. Toughness
6. Long Life
7. Low weight per section
8. Ability to be manufactured and used in long sections
9. Not easily damaged in transporting or installation
10. Low cable pulling resistance

It can be laid rapidly, is light and is not subject to breakage. Creosoted Wood Conduit is very flexible and will withstand considerable movement before the joints open. It is easily cut with a saw.

**Single Duct Type**

Outside Square In.	Stock No.	Inside Bore In.	Wt. Lb. per Ft.
3 1/2 x 3 1/2	(894744)	2	3 1/2
4 x 4	(894745)	2 1/2	4 1/4
4 1/2 x 4 1/2	(894746)	3	5
5 x 5	(894747)	3 1/2	6
5 1/2 x 5 1/2	(894748)	4	7

**SIMPLEX REEL OR DRUM JACKS**



Regardless of the size or weight of your cable, wire rope, belting or rope reels, there is a Simplex Jack that will handle them safely and efficiently. Simplex Reel Jacks are generally ordered in pairs, one for each side of reel.

For outside work where the footing is usually uneven, use the Simplex No. 322. Its "T" shaped base, with the 3-threaded and adjustable steel rods, insures a firm, non-rocking foundation. (Base area 319 sq. inches.) This model is built with both right and left hand bases, so the men operating the Jacks are in sight of each other and raise the reel evenly. No. 322 handles reels from 36" to 84" in diameter and has a double acting mechanism. (Lifts or lowers on both the upward and downward stroke of the lever.) The No. 322 has 3 lifting hooks, 1 for 3" and 2 for 2 1/2" spindles.

Cat. No.	Stock No.	Capacity Tons	Height Inches	Lift Inches	Wt. Lb.	Length of Lever
322	(891025)	10	29	13 3/4	104	5'

**COPE AERIAL CABLE FEEDERS AND STRAIGHTENERS**

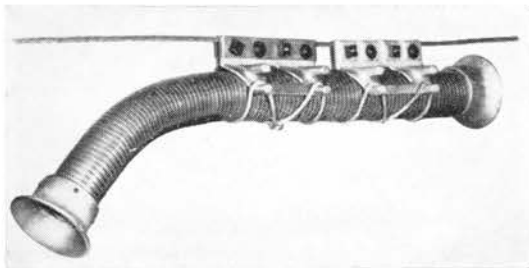

This feeder and straightener is indispensable for pulling in aerial cable. The wide mouth aluminum bells and flexible steel tubing positively prevent danger to cable or sheath. The holding clamps which securely grip the messenger wire can also be used for dead-ending and splicing work.

All interior surfaces are smoothly finished to accommodate up to 3-inch cables.

Furnished complete with 6 feet of tubing and 2 pairs of malleable iron clamps.

Extra lengths of tubing and extra holding and splicing clamps available at extra cost.

6-Ft. Tube with 2 Pr. Malleable Iron Clamps  
Stock No. (890980)

**SCREW TYPE REEL JACKS**

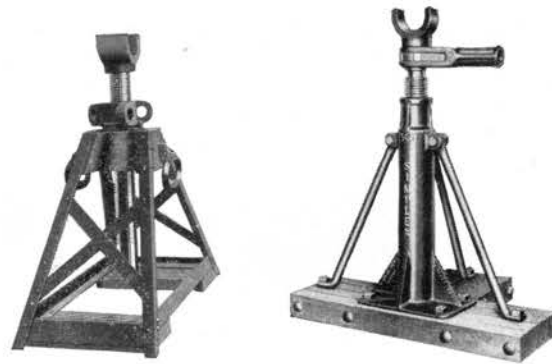

No. 1 CR and No. 2 CR

No. 3 CR

The Simplex Screw Type Reel Jacks provide an economical method of handling standard weight reels. No. 1 CR for reels 40" to 60" in diameter, No. 2 CR for 60" to 92" reels. The 3-Way nut makes it possible to operate the Simplex more easily and faster than any other "A" frame screw type reel Jacks. Nos. 1 CR and 2 CR have 1 spindle cap for 2 1/4" spindles. No. 3 CR, for reels 50" to 84" in diameter, is recommended for heavy duty field work. The braced "T" base has an area of 240 sq. inches, insuring stability. The ratchet lever socket makes this jack faster operating than Nos. 1 CR and 2 CR.

Cat. No.	Stock No.	Capacity Tons	Height Inches	Lift Inches	Wt. Lb.	Length of Lever
1 CR	(891015)	5	19 3/4	13 1/4	60	
2 CR	(891016)	5	30 1/2	18	88	
3 CR	(894835)	15	25 1/2	17 1/2	72	42"

**TYPE B COPE CABLE REEL JACKS**

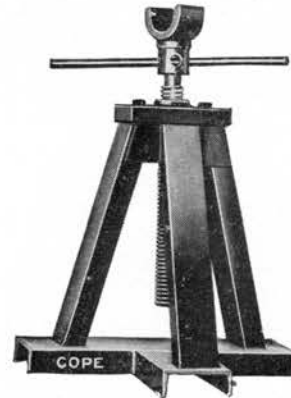

Constructed entirely of heavy welded steel channel section, thereby making an extremely rugged piece of equipment. The base sections are 5-inch, 6.7-pound channel; the side legs are of 4-inch, 5.4-pound channel and the back leg of 3-inch, 4.1-pound channel. The base size is 21 inches across and 12 inches in width, to give maximum support in both directions.

Wrought steel square thread has a diameter of 1 3/4 inches and a length of 18 inches. Swivel yoke has a minimum height of 25 inches and a maximum height of 40 inches. Capacity, 10 tons.

Stock No. (891014)

**COPE CABLE BENDER**



The Cope Cable Bender has been designed as a universal tool. It has an adjustable yoke which permits work in close quarters with the seven positions of the handle. By simply pulling back on the sleeve the ratchet is released, permitting the handle to be placed in any position desired.

The wide bearing surface and rounded edges of the shoes absolutely prevent injury or deformation of the cable sheath.

The yoke and arm are made of alloy steel castings with handle of heavy wall steel tubing. Every Cable Bender is given a thorough load test before leaving the plant.

Stock No. (890986)

**TYPE 264 COPE MANHOLE GUARD RAILS**



This guard rail is made with a completely welded construction, thereby doing away with the customary pipe fittings and riveted eyes which have always proved the weakest points in manhole guard construction. Closely follows the design of the new American Telephone & Telegraph Company's standard.

Made of 3/4-inch standard black steel pipe with seamless steel tubing sleeves. The bow-shaped wing brace holds this rail absolutely rigid against collapse when in place, leaving the open side entirely free for work. The chains allow this rail to be padlocked to any pole, etc.

Unless otherwise ordered, all rails are painted with two coats of Signal Red Enamel.

Dimensions, 32x32x42 inches high, open; 32x2x42 inches, folded.

Weight, 49 pounds. Stock No. (890995)

**MANHOLE FRAMES AND COVERS**



Diameter of cover, 22 1/2 inches; diameter of base, 36 inches.  
 Catalog No. . . . . . 202    204    206    208    211  
 Stock No. . . . . . (890989)(890990)(890991)(890992)(890993)  
 Height . . . . inches    9       9       9       9       6  
 Weight . . . . pounds    550    450    425    400    350

**MANHOLE COVER HOOKS**



This is a useful tool for the subway construction force. It is designed to easily raise a heavy manhole cover by prying the wedged point of the hook under the groove provided in the cover for the purpose.

The hook is made of an excellent quality of electric tool steel suitably hardened at and adjacent to the hook to prevent its bending, and at the same time sufficiently tough to prevent breaking off.

Over-all length, 26 1/2 inches. Stock No. (890994)

**MANHOLE LADDERS**



The 6 1/2, 8, 10 and 12-foot lengths have sides of 1 1/2 x 9/16 x 3/16-inch channel and rungs of 3/8-inch round open hearth steel, hot galvanized. The 14-foot ladder is made of channel 2 1/2 x 3/8 x 3/16-inch sides. The rungs pass through the sides and are riveted over on the outside. They are 12 inches apart spaced from the bottom rung which is placed 12 inches from the bottom of the ladder.

Standard package, 5.

Rung spacing, 12 inches; Inside width, 12 inches.

Cat. No.	Stock No.	Length Feet	No. of Rungs	Ship. Wt. Lb. Each
9111	(890981)	6 1/2	6	24 1/2
9112	(890982)	8	7	30
9113	(890983)	10	9	38
9115	(890984)	12	11	46
9117	(890985)	14	13	53

## WARNING SIGNS, MANHOLE



This warning sign is light in weight yet durable. Legs are of 1/2-inch high carbon steel. Has 1/4-inch flange around edge of lettered side.

Has two hollow handles for adjusting angle of the legs. These handles also serve as flag sockets, and each is equipped with a lantern lock.

Black letters, 5 1/2 inches high, on traffic yellow background. Height, 43 inches. Width, 28 inches. Thickness, 1/4 inches. Size folded, 28 x 28 x 1 1/4 inches.

Weight, 23 pounds. Stock No. (890996)

## PEIRCE UNDERGROUND CABLE RACKS Hot Galvanized



Rack section is made in three lengths which can be combined into almost any desired length. Section is made from 1 1/2 x 3/16 x 3/16-inch open hearth steel channel, amply strong to support the heaviest cable. Should be fastened to manhole wall with 1/2 x 4-inch Peirce Expansion Bolts.

Hook is cut from open hearth steel T section and has a smooth, well rounded top surface 1 1/2 inches wide which will not injure the sheaths of cable. Steel size, 1 1/2 x 1 1/16 x 3/16 inches. Easily attached and with the weight of the cable on it, holds securely to the channel back.

### Racks

Cat. No. ....	*2124	*2125	*2126
Stock No. ....	(890969)	(890970)	(890971)
No. of Holes .....	8	14	18
Hook Hole Spacing .. inches	1 1/2	1 1/2	1 1/2
Overall Length .. inches	15	24	30
Bolt Hole Spacing .. inches	13 1/2	22 1/2	28 1/2
Ship. Wt. per 100 .. lb.	155	265	315

### Hooks

Cat. No. ....	*2131	*2132	*2133
Stock No. ....	(890972)	(890973)	(890974)
Extension from Face of Rack .. inches	4	7 1/2	10
Ship. Wt. per 100 .. lb.	61	110	135

†A. T. & T. Co. Std.      \*Western Union Std.

## CABLE RACK INSULATORS



Catalog No. 2120 .....	Stock No. (890975)
Radius for Cable .....	inches 1 1/2
Length Along Hook .....	inches 3
Width .....	inches 2 3/4
Ship. Wt. per 100 .....	lb. 105

## HUBBARD PULLING-IN IRONS



### For Manholes Hot Galvanized

This iron is set into the concrete or brick walls of street vaults opposite duct entrances to provide a convenient and strong attachment for block and tackle when installing or removing cables.

Catalog No. 9119 .....	Stock No. (890968)
Diameter Steel .....	inches 7/8
Extension from Wall .....	inches 9
Ship. Wt. per 100 .....	lb. 550

## COPE CABLE DUCT SHIELDS

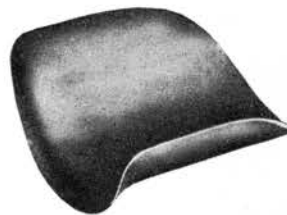

This shield is used to protect the lead sheath of the cables at the mouth of the conduit. It permits expansion and contraction of the cables without injury and may be placed under the cable after installation.

Made up for both 3 and 3 1/2-inch conduits in both 18-gage

galvanized sheet steel and 16-gage sheet zinc.

	Gal. Steel	Zinc	
Size .....	inches 3    3 1/2    3    3 1/2		
Stock No. ....	(890976)(890977)(890978)(890979)		

## CHANCE SAFETY CABLE CARS

Chance Cable Cars leave nothing to be desired in the way of safety, service and convenience. They are correctly balanced for comfort and the rubber tread wheels give a smooth ride over cable rings. They are equipped with hand brakes and can be furnished with wheel guards for added safety. Chance flexible cars are adjustable.

### No. 27 Flexible Car



The Chance Flexible Cable Car can be collapsed, strapped or tied for convenient transportation aboard a train, bus or automobile. It is adjustable up or down, by snaps and chain.

The chain is made of steel, electric welded on sides of links to guard against weld opening. Snaps used are lineman's snaps of drop forged, galvanized steel.

The No. 7 Seat is made of high grade fir lumber, reinforced with strap steel imbedded in wood.

Cat. No. 27	Stock No. (890002)	Description Flexible Car	Height Adjustable	Width 21"	Weight 27 lbs.
-------------	--------------------	--------------------------	-------------------	-----------	----------------

**BIERCE CABLE ROLLERS**

Frame of forged steel, roller of cast iron, supported and protected on both sides by pressed steel discs.

Hinged member when thrown back allows ample opening for easy removal of frame from messenger wire and cable after cable has been drawn and tied up in position.

Self-contained hinge and grip. Impossible to become disengaged from the messenger wire. Adaptable to all sizes of cable, practically indestructible. Construction assures perfect alignment.

Stock No. (891006)



**NO. LGI LITTLE GIANT SLACK PULLERS**

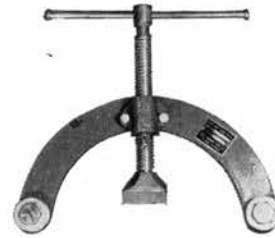

This slack puller eliminates the necessity of leaving slack at the poles for terminal splices, and when a splice is completed the cable will return to its original position.

This handy tool should be in every cable man's kit. It requires but 14 inches on the strand and will pull slack in maximum size cables supported by 16 M. strand. It will not injure cable or strand.

Stock No. (891007)

**BUCKINGHAM CABLE SLITTER  
AND RINGING TOOL  
No. 7082**



A cable slitter, ringer and spreader, it is three-tools-in-one. Its use allows any workman to do a precision job of slitting, ringing and spreading any cable up to 3 1/8" in diameter without cutting or damaging the insulation inside the sheath.

A carefully heat-treated cutting blade is easily and quickly adapted to cut cable sheathing of any thickness from 1/32" to 9/32". It is held securely to the required cutting depth by a set-screw and lock-nut. The cutting area of the blade is designed so that it has a tendency to hold the slitter against the cable when the cut is being made. The blade is wedge-shaped to spread or open the sheathing as it is being cut. Cable can be cut in either direction by hammering the driving heads which are slightly hardened and will not easily batter or mushroom.

It will ring any cable up to 3 1/8" in diameter by simply setting the tee-handle screw adjustment.

When ringing is completed, the adjustable dog is easily inserted into the slit sheathing and only slight pressure on the 7 1/2" handle of the tool is necessary to spread or remove the desired section. When not in use, the spreading dog drops into the body frame and does not impede other operations.

The tee-handle, for adjusting the ringing blade and cutting dog, operates easily from a fixed position at the end of the body frame.

An Allen wrench for adjusting or removing cutting blade, and an extra cutting blade are provided as standard equipment.

No. 7082, Cable Slitter complete with extra blade and Allen Wrench. Weight 1 lb., 7 ozs. Shipping weight per 12, 25 lbs.

Catalog No. 7082 Stock No. (894556)

No. 8083, Slitting or Cutting Blade only. Weight 1 oz. Shipping weight per 12, 1 lb. Stock No. (894557)

**NEALE MODEL B CABLE SPINNER**



Designed for use by a construction crew to place and spin new cable or maintenance spinning of existing cable. Operates on ball bearing races with double drive mechanism which eliminate slipping. This machine is instantly adjustable to take cable from minimum size to a maximum diameter of 2 1/4 inches. The spinning wire supply is always visible. A ratchet on the strand wheel makes it impossible for the spinning wire to slack off when pull on the tow line is released. The machine comes furnished with one lashing wire clamp, two adjustment wrenches, one screwdriver, one open end wrench, one tow rope, and packed in spinner chest. Machine size is: length 24 inches, diameter 10 inches, weighs 42 pounds.

This machine has compound gearing that eases the spinning operation on up grades. The hand crank has a positive snap action that can be changed from regular to compound drive instantly.

Stock No. (891004)

## NEALE MODEL D CABLE SPINNER

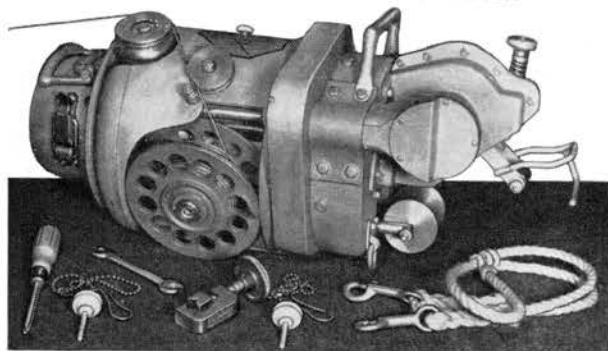

A machine designed expressly for one-man operation in spinning new cable or maintenance spinning of existing cable, it may be operated either by a hand crank or pulled along the supporting strand by a man on the ground. A dead weight of 50 to 100 pounds may be substituted for a rider to prevent slippage when operated from ground.

The two supporting trolley wheels are linked by means of a sprocket chain which insures positive driving action for both front and rear wheels. The machine is transferred easily at pole by removing gate in spinner head.

The machine is shipped with the following equipment: spinner chest, seat, safety belt, one tube of grease and one lashing wire clamp.

Stock No. (894681)

## NEALE SPINNING OR LASHING WIRE

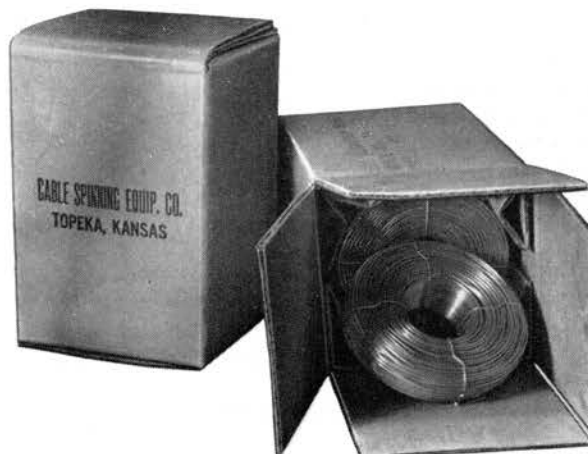

In any consideration of spinning wire, weight is certainly of the utmost importance. Aluminum wire is approximately one-third the weight of steel or copper of equivalent diameter. Alloy 52S $\frac{1}{4}$ H with .091" diameter has good strength characteristics with an ultimate tensile strength of 197 lbs. minimum load.

The aluminum spinning wire is preferred by the workmen in the field after first trial use because it threads on machine easily, giving easy motion to operator and machine.

### Weight and Strength

Catalog Number	Description
1A	.091 Heavy Galvanized Spinning Wire. Special soft annealed spinning wire. For use where corrosion conditions are normal. Used with steel strand.
12A	.091 Standard Galvanized Spinning Wire. Special soft annealed spinning wire. For use where corrosion conditions are light. Used with steel strand.
5A	.061 Galvanized Spinning Wire. Soft annealed spinning wire. Used on small cable up to and including 51 pair, 26 gauge in areas where corrosion is light. Used with steel strand.
10A	.061 Type 316 Stainless Steel Spinning Wire. Highest corrosion resisting spinning wire under all conditions. Life expectancy: At least 3 to 5 times the life of extra heavy galvanized wire.
11A	.061 Type 430 Stainless Steel Spinning Wire. Very high corrosion resisting wire under all conditions. Used with steel strand.
4A	.091 Copperweld Spinning Wire. Special soft. Recommended for use in areas subject to corrosive fumes of atmosphere. Used only with Copperweld strand.
6A	.090 Copper Spinning Wire. Solid soft drawn spinning wire. Used in heavy corrosive areas. Used only with Copperweld strand.
7A	.091 Aluminum Alloy Spinning Wire. High corrosion resistance. Used with steel strand.

All types spinning wire furnished in Type 1A hub, cone shaped hub. Standard on all Neale Spinning Machines.

Type 3A hub, straight hub, standard on Western Electric Pull Type Spinner, furnished on request only.

Spinning wire packed 6 coils per carton.

Stock No. (891005)

Order Numbers 1A, 4A, 6A, 7A and 12A all contain approximately 325 feet per coil. Order Numbers 5A, 10A and 11A contain approximately 650 feet per coil.

In figuring the amount of spinning wire, add 10% to the length of the cable that is to be spun.

## MARLINE TWINE

Furnished in one-pound balls in both the 2 and 3-ply varieties.

Catalog No.	Stock No.	Ply
415	(890599)	2
416	(890600)	3

## CRAPO GALVANIZED STEEL CABLE LASHING WIRE



Manufactured specially for lashing cable to messenger strand. For use in modern cable spinning machines. Diameter .091 inch. Heavily galvanized for long life. Put up in neat compact coils, 6 coils to carton.

Dimensions of coil: Arbor hole, straight hub, 1 $\frac{7}{8}$  inches, minimum; outside diameter (nominal) 6 inches; width (nominal) 1 $\frac{1}{2}$

inches. Length of wire in coil, 325 feet, plus or minus 10 feet. Nominal weight of coil, 7.2 pounds.

Stock No. (894894)

## "STAINLESS STEEL" CABLE LASHING WIRE

Developed primarily for use in highly corrosive atmospheres, this wire is being used also in other locations. Available in the following sizes and coil lengths:

Diameter	Approx. Coil Length	Nom. Wt. per Coil
.065 inch	325 feet	3.6 pounds
.065 inch	450 feet	5.0 pounds
.065 inch	650 feet	7.2 pounds
.045 inch	1200 feet	6.37 pounds

Stock No. (894895)

**AERIAL CABLE SPLICERS' TENTS**

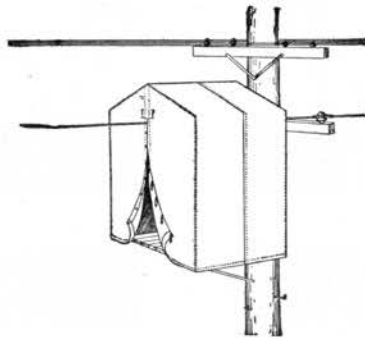

Used in conjunction with pole platforms to protect cable splicers in cold and stormy weather. Made of 28½-inch best available quality cotton duck. Roof is spread and supported by means of a collapsible 3-ribbed galvanized metal framework which fastens to cable suspension strand. On each of 2 opposite sides of tent there is an opening which can be laced from the inside after tent is erected.

Cat No.	Stock No.	Lgth. In.	Width In.	Height In.	Wt. Lb.
S	(890999)	38	54½	104	38
L	(891000)	54	54½	104	45

**NATIONAL CABLE RINGS**



Easily and quickly placed on the strand and once in position are rigidly immovable.

Easy to install.

Cable can be pulled in from either direction, and neither the strain of this operation nor the swaying of the cable by the wind, can move the ring from its original position, for the greater the strain, the tighter the grip.

Hot dip galvanized; made in all strand sizes. Specify strand size desired, as well as size of ring.

Size Inches	Stock No.	Std. Pkg.	Wt. Lb. per 1000
1½	(890576)	1000	47
2-Light	(890577)	500	66
2-Heavy	(890578)	500	90
2½	(890579)	500	108
3	(890580)	400	125
3½	(890581)	300	140
4	(890582)	250	192
4½	(890583)	200	210

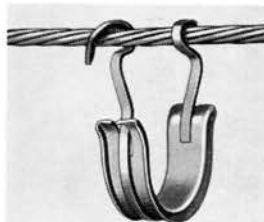

**GROUND TENTS**

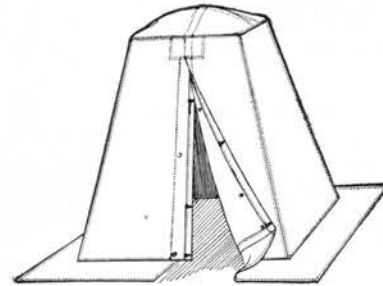

This tent is used in conjunction with all kinds of ground work, especially when working in manhole. Covering is best available quality duck. Iron pipe frame has four legs, each of which is provided with a joint, so it can be folded back on itself and then the legs fold in toward the center of tent. Has no center pole, but is held up at the four corners. A 12-inch sod cloth runs all around base of tent. No stakes included.

Size, 6 x 6 feet square base at bottom, 3 feet square at top, 6½ feet high.

Approximate weight, 60 pounds. Stock No. (890997)

**EXTRA LONG GALVANIZED CABLE RINGS**

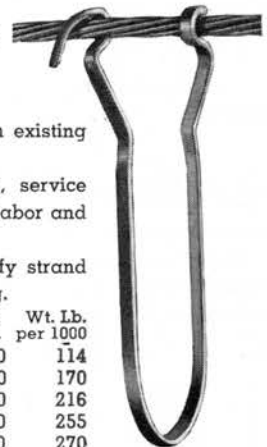

For placing a second cable on an existing messenger.

When this cable ring is used, service interruption and expense in time, labor and materials is eliminated.

Made in all strand sizes; specify strand size desired as well as size of ring.

Size In.	Stock No.	Lgth. Inches	Std. Pkg.	Wt. Lb. per 1000
1½	(890584)	4¾	500	114
2	(890585)	5¼	300	170
2½	(890586)	6¾	250	216
3	(890587)	7½	200	255
3½	(890588)	8	200	270

**GALVANIZED CABLE RING SADDLES**

Reduces ring cutting on lead sheath due to vibration and assures a longer life to the cable.

Made of steel, hot dip galvanized after forming.

Size Inches	Stock No.	Std. Pkg.	Wt. Lb. per 1000
1½	(890589)	1000	90
2	(890590)	1000	100
2½	(890591)	500	110
3	(890592)	500	135
3½	(890593)	500	150



## NATIONAL MARLINE CABLE HANGERS

The hooks are made of No. 9 spring steel wire and are regalvanized by hot dip process after they are formed.

The loop is three-ply houseline. Specify length of loop when ordering.



Max. Diam. Cable Inches	Stock No.	Length Loop Inches	Approx. Ship. Wt. Lb. per 1000
7/8	(890601)	9	35
1	(890602)	10	36
1 1/8	(890603)	11	37
1 1/4	(890604)	12	38
1 1/2	(890605)	13	39
1 5/8	(890606)	14	40
1 3/4	(890607)	15	42
2	(890608)	16	45
2 1/4	(890609)	18	49
2 1/2	(890610)	20	62

## DIAMOND AERIAL CABLE SUPPORTS

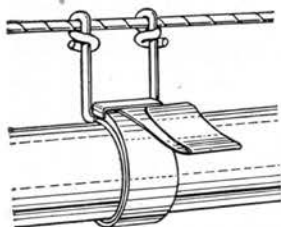

The purpose of aerial cable supports is to supply flexible supports at each side of the pole to prevent ring cut. The strap is wrapped around the cable three times over itself, passing through the hinge member. Adjustable to any height.

The supports are placed two on each side side of each pole. They are placed 20 inches apart.

Aerial cable support is composed of a zinc strap, a hinge joint member which holds free end of zinc strap in position on a soft galvanized U shaped wire 5 inches long.

Size No.	Stock No.	Length Strap Inches	Diam. of Cable or Sleeve In.	Circumference Inches	Std. Ctn.	Wt. Lb. per 1000
1	(890615)	10	3/4	2 5/16	500	84
2	(890616)	16	1 3/16	3 3/8	500	110
3	(890617)	22	2	6 5/16	300	130
4	(890618)	28	2 3/8	8 5/16	300	162
5	(890619)	34	3 1/8	10	300	186
6	(890620)	50	†5	15 13/16	200	256
7	(890621)	64	†6 1/2	20 1/2	200	315
*8	(890622)	64	†6 1/2	20 1/2	200	350

\* No. 8 is exactly the same as No. 7 except No. 8 has 10-inch long U shaped wire on end instead of 5-inch long wire as on regular supports.

†Maximum diameter of sleeve.

## RELIABLE ZINC CABLE HANGERS

For supporting lead covered cable or insulated conductors to galvanized steel strand.

These zinc cable hangers wrap around the cable, securely attaching them to the messenger, minimizing creep bow and fatigue. No sheath cuts—no replacement of rings—no expensive equipment needed. Will outlast the cable.

The zinc hangers bond the cable sheath and strand to give added protection against lightning. They are strong, easy to install and economical.

Zinc hangers and steel strand should be used with neoprene jacketed wires.

## RELIABLE CABLE HANGERS (Cont.)

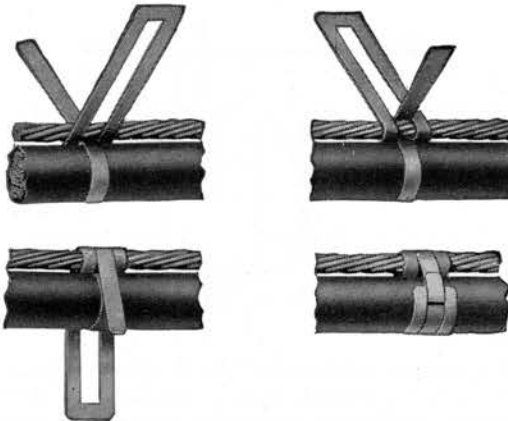

Cat. No.	Stock No.	Length	Capacity Strand	Cable Max. Min.	Ship. Wt. Lb. per M
1	(890611)	7 7/8"	5/16"	3/4" 1/2"	40
2	(890612)	11"	3/8"	1 1/8" 1/2"	60
3	(890613)	14"	3/8"	1 5/8" 1/2"	98
4	(890614)	16"	3/8"	1 7/8" 7/8"	115

## DIAMOND WIRE AND CABLE CLAMPS



Off-Set Type

For interior wiring. Standard finish is galvanized, but ivory and brown enamel finish can be provided for exposed wiring at 50 percent additional to the net prices, on clamps up to 3/4 inch.

Cat. No.	Stock No.	Cable Size Min. Max.	Pipe Size In.	Screw Hole In.	Wt. Lb. per 100
403	(890647)	5/32 7/32	—	9/64	.4
405	(890648)	1/4 5/16	—	9/64	.5
406	(890649)	5/16 3/8	—	7/32	1.
407	(890650)	3/8 1/2	1/8	7/32	1.1
408	(890651)	1/2 9/16	1/4	7/32	1.2
409	(890652)	9/16 5/8	—	9/32	2.5
411	(890653)	5/8 1 1/16	3/8	9/32	2.87
413	(890654)	3/4 7/8	1/2	9/32	4.12
417	(890655)	1 1 1/16	3/4	9/32	5.31
421	(890656)	1 1/8 1 1/2	1	9/32	9.75
425	(890657)	1 1/2 1 3/4	1 1/4	9/32	10.62
430	(890658)	1 13/16 2	1 1/2	9/32	12.43
435	(890659)	2 2 3/8	2	9/32	16.
442	(890660)	2 1/2 2 7/8	2 1/2	9/32	18.43

## DIAMOND TWO-HOLE CONDUIT AND CABLE STRAPS



This strap is Diamond Galvanized and is designed to withstand heavy strains and vibration. Because of its great strength fewer straps need be used in conduit or cable runs.

Cat. No.	Stock No.	Cable Size Inches	Pipe Size Inches	Screw Hole Size In.	Wt. Lb. per 100
T-7	(890661)	7/16	1/8	13/64	1.5
T-10	(890662)	5/8	1/4	7/32	2.0
T-11	(890663)	1 1/16	3/8	9/32	3.2
T-12	(890664)	3/4	—	9/32	4.1
T-14	(890665)	7/8	1/2	9/32	4.4
T-16	(890666)	1	—	9/32	6.9
T-18	(890667)	1 1/8	3/4	9/32	7.3
T-20	(890668)	1 1/4	1	9/32	13.5
T-24	(890669)	1 1/2	—	9/32	15.25
T-26	(890670)	1 5/8	1 1/4	9/32	16.5
T-28	(890671)	1 3/4	—	9/32	17.
T-30	(890672)	1 7/8	1	9/32	19.

**DIAMOND 1-HOLE STEEL CLAMPS**



Makes a very efficient fastening where lighter construction is to be used, and where it will not be subjected to severe strains.

Sizes for thin wall conduit.

Made of cold rolled mild steel annealed and Diamond galvanized after forming.

Cat. No.	Stock No.	Cable Size In.	Reg. or Pipe In.	Conduit Hole In.	Screw Size In.	Wt. Lb. per 100
L-3	(890629)	3/16	—	7/32	1	
L-4	(890630)	1/4	—	7/32	1	
L-5	(890631)	5/16	—	7/32	1	
L-6	(890632)	3/8	1/8	7/32	1	
L-7	(890633)	7/16	—	7/32	1.1	
L-8	(890634)	1/2	—	7/32	1.2	
L-9	(890635)	9/16	—	7/32	1.2	
L-10	(890636)	5/8	1/4	7/32	1.3	
L-11	(890637)	11/16	3/8	9/32	4	
L-12	(890638)	3/4	1/2	9/32	4.5	
L-14	(890639)	7/8	—	9/32	5.0	
L-16	(890640)	1	3/4	9/32	7.0	
L-18	(890641)	1 1/8	—	9/32	7.5	
L-20	(890642)	1 1/4	1	9/32	15	
L-24	(890643)	1 1/2	—	9/32	16	
L-26	(890644)	1 5/8	1 1/4	9/32	17	
L-28	(890645)	1 3/4	—	9/32	19	
L-30	(890646)	1 7/8	1 1/2	9/32	20	

**RELIABLE CABLE GRIPS**

Reliable Cable Grips have been carefully engineered for extra wearing quality as wires pull with evenly distributed load.

Pulling grips for aerial or underground cable, luffing grips for pulling slack or removing old cables, split for moving cables where an end is not accessible are all supplied in a full range of sizes. Standard grips are made of steel wire.

**HARD WIRE PULLING GRIPS**



These grips are very tough and rather stiff, and they withstand great wear. Used with success by companies that pull a large amount of underground cable. The grip must fit exactly for proper performance.

For swabbing ducts, this grip can be heavily packed with waste and is very satisfactory.

**Double Weave — Length as shown**

Cat. No.	Stock No.	Cable Dia. In. Min.	Cable Dia. In. Max.	Tensile Strength Lb.	Ship. Wt. Lb. Each
*802	(890919)	3/4	1	6,300	1
*803	(890920)	1	1 1/2	6,300	1 1/2
*804	(890921)	1 1/2	2	8,500	1 1/2
*805	(890922)	2	2 1/2	15,000	2
†806	(890923)	2 1/2	3	18,300	4
†807	(890924)	3	3 1/2	23,000	3
†808	(890925)	3 1/2	4	23,000	4
†812	(890926)	3/4	1	6,300	1 1/2
†813	(890927)	1	1 1/2	6,300	1 1/2
†814	(890928)	1 1/2	2	8,500	1 1/2
†815	(890929)	2	2 1/2	15,000	2
†816	(890930)	2 1/2	3	18,000	3
†817	(890931)	3	3 1/2	23,000	5
†818	(890932)	3 1/2	4	23,000	5 1/2

\*22" Long; †30" Long; †45" Long.

**RELIABLE SPLIT GRIPS**



These steel grips are for moving working cables or any cables, where the end is not accessible. A special arrangement of strong hooks, with few hooking operations, makes the grip very easy to fasten or unfasten. If the simple tool is lost, a nail or small screwdriver will do the job.

**Single Weave — 18" Length**

Cat. No.	Stock No.	Cable Dia. In. Min.	Cable Dia. In. Max.	Tensile Strength Lb.	Ship. Wt. Lb. Each
*862	(890947)	3/4	1	3,300	1
863	(890948)	1	1 1/2	6,300	1 1/2

\*No Hooks—Wire Lacing furnished.

**Double Weave — 24" Length**

Cat. No.	Stock No.	Cable Dia. In. Min.	Cable Dia. In. Max.	Tensile Strength Lb.	Ship. Wt. Lb. Each
974	(894736)	1 1/2	2	12,600	3
975	(894737)	2	2 1/2	16,800	4
976	(894738)	2 1/2	3	24,600	4 1/2
977	(894739)	3	3 1/2	24,600	5
978	(894740)	3 1/2	4	24,600	5 1/2

**DOUBLE EYE LUFFING GRIPS**



For pulling slack or removing old cables. Shortest body permits longest pull in cramped manhole. Pull is distributed as evenly as possible on all wires, which results in a very long wearing grip.

**Single Weave — 18" Length**

Cat. No.	Stock No.	Cable Dia. In. Min.	Cable Dia. In. Max.	Tensile Strength Lb.	Ship. Wt. Lb. Each
842	(890933)	3/4	1	3,300	1
843	(890934)	1	1 1/2	6,300	2

**Double Weave — 24" Length**

Cat. No.	Stock No.	Cable Dia. In. Min.	Cable Dia. In. Max.	Tensile Strength Lb.	Ship. Wt. Lb. Each
954	(894731)	1 1/2	2	12,600	2 1/2
955	(894732)	2	2 1/2	16,800	3
956	(894733)	2 1/2	3	24,600	5
957	(894734)	3	3 1/4	24,600	5
958	(894735)	3 1/2	4	24,600	5

**PLAIN FLEXIBLE PULLING GRIPS**

Single weave grips are for pulling aerial cable and feed through rings without displacing them. Also used for small underground cables where ducts are clean or soil is not gritty. Double weave grips are for pulling underground cables where wear is light and use of reinforced grips is not warranted.

**Single Weave — 24" Length**

Cat. No.	Stock No.	Cable Dia. In. Min.	Cable Dia. In. Max.	Tensile Strength Lb.	Ship. Wt. Lb. Each
822	(890909)	3/4	1	3,350	1
823	(890910)	1	1 1/2	6,300	2
824	(890911)	1 1/2	2	8,400	1 1/2
825	(890912)	2	2 1/2	12,300	2 1/2
826	(890913)	2 1/2	3	15,400	2 1/2

**Double Weave — 36" Length**

Cat. No.	Stock No.	Cable Dia. In. Min.	Cable Dia. In. Max.	Tensile Strength Lb.	Ship. Wt. Lb. Each
933	(894727)	1	1 1/2	10,500	2
934	(894728)	1 1/2	2	12,500	3
935	(894729)	2	2 1/2	18,500	4
936	(894730)	2 1/2	3	24,500	4 1/2

## ANHYDROUS PREPARED COTTON SLEEVES

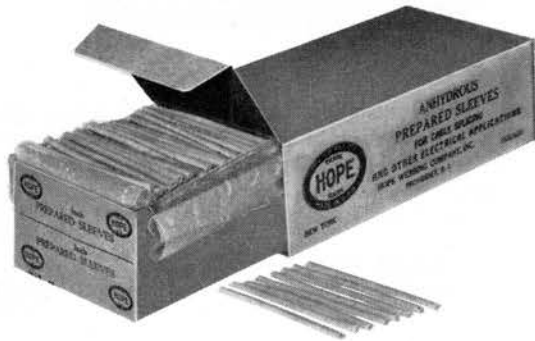

Anhydrous prepared sleeves are cylindrical in form, permanent, ready for application; no stretching necessary; cut to length; no waste; no fraying; with clean-cut ends; uniform in size. They are free from moisture, with no leakage of current and no cross circuits; impervious to moisture, permanently sealed against that deadly foe. Length  $3\frac{1}{4}$  inches.

Packed in moisture-proof cartons, convenient for storage, convenient for operator, protection for sleeves and for apparatus.

Use prepared sleeves over all joints in conductors, exposed leads or wherever there is an exposed wire.

Cat. No.	Stock No.	Nom. Diam. In.	Approx. No. per Ctn.	Approx. Wt. Oz. per Ctn.
346-H-5	(890686)	3/32	900	15
345-H-5	(890687)	1/8	700	14
1030-H-5	(890688)	5/32	400	12
61-H-5	(890689)	1/4	200	12
79-H-5	(890690)	3/8	100	10

## PAPER INSULATORS FOR CABLE



Used to insulate bare joints of cable construction where splices have been made.

One sleeve on each wire of each pair at junction makes a compact and reliable insulation.

Diameter Inches	Stock No.	Used for Straight Splices	Standard Package Quantity	Weight Pounds per 1000
1/8 x3	(890684)	22 Ga.	175	1
3/16x3	(890685)	19 Ga.	110	1

## LEAD SLEEVES

Lead sleeves for making cable splices can be furnished in any size and length. Following are standard sizes for No. 22 gage cable specified. Walls of sleeve,  $\frac{1}{8}$ -inch thick. All sizes can be furnished in any length.

Size of Cable	Stock No.	Inside Diam. In.	Length Inches	Weight, Pounds Per Foot	Pounds Per Sleeve
10 & 15 Pair	(890694)	1 $\frac{1}{4}$	16	2 $\frac{1}{2}$	3 $\frac{1}{2}$
25 Pair	(890695)	1 $\frac{1}{2}$	16	3	4
50 & 100 Pair	(890696)	2	20	3	5
150 Pair	(890697)	2 $\frac{1}{2}$	22	5	9 $\frac{1}{4}$
200 Pair	(890698)	3	22	6	11
300 Pair	(890699)	3 $\frac{1}{2}$	22	7	12 $\frac{3}{4}$
400 Pair	(890700)	4	22	8	14 $\frac{1}{2}$
600 Pair	(890701)	4 $\frac{1}{2}$	22	9	16 $\frac{1}{4}$

## NO. 1065-A FAULTLESS YELLOW BEESWAX COMPOUND



Furnished in 1-pound bars. Stock No. (890702)

## PARAFFIN



Guaranteed 137-140° test. Commercially refined white paraffin for boiling out paper insulated cables before splicing.

Furnished in standard 11-pound cakes. Stock No. (890750)

## PLUMBER'S CANDLES

Sizes  $4\frac{3}{4}$  x  $1\frac{1}{4}$  inches, 5 to a pound.

Type	Stock No.	Stearic Acid %	Used For
Ordinary	(890704)	5	Lighting Purposes
Beacon	(890705)	20	General Purposes
Erie	(890706)	35	Tinning & Fluxing

## STEARINE WICKLESS CANDLES

A. T. & T. Specifications.

Size Inches	Stock No.	No. to Lb.
3 $\frac{1}{2}$ x $1\frac{1}{4}$	(890709)	7
8 x $1\frac{1}{4}$	(890710)	3

**No. 1061 STROMBERG-CARLSON  
CABLE COMPOUND**



Furnished in 1 1/4 gallon cartons.  
 Cat. No. 1061      Stock No. (890712)      Wt. per Carton 10 lb.

**BONDING RIBBON**

Bonding ribbon is a soft tinned copper ribbon in size of 3/8 x 1/16 inch. Approximately 12 1/2 feet to the pound. Stock No. (890703)

**DILLON TEMPEROMETER  
An Unbreakable Cablemen's  
Thermometer**

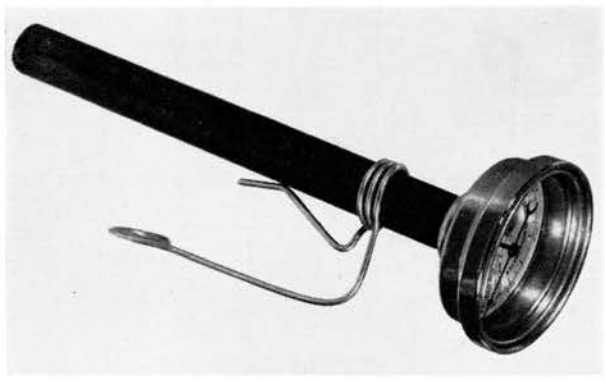

The Dillon Temperometer is a scientific instrument that registers the correct temperatures of cable damming and impregnation waxes, paraffin, compounds and wiping solder. In designing the Model, tests to determine the correct temperatures of these materials were held in laboratories of some of the largest Telephone and Power Utilities in the United States.

The Temperometer is rugged yet compact. It is 9 inches in length and the tube is 3/4 inches in diameter. The dial is 2 1/8 inches in diameter, calibrated from 150° to 1000° F.

Laboratory and field tests made by the largest Telephone and Power Utility companies who have been using Dillon Temperometers, have proved under gas tests, that joints wiped with underheated solder are porous, and with overheated solder, crystalized, both resulting in defective joints.

Stock No. (890808)

**DOE'S PLUG BURNISHING PASTE**



For polishing cord plugs in telephone exchanges. It insures an electrically perfect contact and insulates between tip and ring.

Guaranteed to be absolutely non-corrosive and electrically perfect.

Stock No. (890748)

**DOE'S COMMUTATOR BURNISHING PASTE**

For Commutators—Slip Rings—and Any Electrical Contacts.

This preparation cleans, polishes and insulates between the commutator segments. Assures perfect contact and assures the elimination of noise, sparking and other commutator troubles.

Stock No. (890749)



**NO. 0 KORITE CABLE COMPOUND**

No. 0 Korite is a non-corrosive, acid-resisting, non-conducting material applied to cables. Sets quickly and forms a protection against chemical fumes.

For new cable 100 pounds coats 325 feet of 25 pairs, 300 feet of 50 pairs, 200 feet of 75 pairs, 165 feet of 100 pairs, 150 feet of 125 pairs, 125 feet of 150 pairs, 100 feet of 200 pairs of No. 22 B. & S. gauge new cable, if properly applied. This is sufficient under normal conditions, but where toilets, stables, gas plants, cinders, train smoke or other conditions threaten the cable, a thicker coating should be given.

Sold in 100 pound cartons. Stock No. (890713)

**NO. 32 METAL RIM TAGS**



tag, 1" diameter.

100 in a bunch

Designed especially for use on heavy merchandise which will receive much handling. Cut from stock which is clear white or evenly colored (red, green, or yellow) with an exceptionally fine writing surface. The rims, of bright, non-tarnishing, smoothly cut metal, protect the edges, prevent bending, and improve the appearance. Strung with strong twine in colors to match the tags. Size of

500 in a box

Stock No. (890746)

## PROTEK-SORB DESICCANT For Drying Cable Splices



Use of Protek-Sorb Desiccant is an improved method of drying cable splices eliminating the hazards and inconveniences of boiling-out cable splices with hot, melted paraffin. Splices are dried by pouring a recommended quantity of Desiccant into the splice before it is closed.

This Desiccant is a granular material, chemically inert and non-corrosive. It will not dust, cake, powder nor liquify when used—even when completely saturated it looks and feels perfectly dry. Has exceptionally high dielectric constant.

### Features

Protek-Sorb Desiccant granules are sized for most efficient action plus practicability—the 28-200 mesh size assures equal distribution throughout the splice. Its unequalled capacity, the ease with which it can be used and the fact that it is chemically inert has won for it the endorsement of leading telephone laboratories. Leading telephone companies use Protek-Sorb Desiccant exclusively when installing, repairing and splicing telephone cable.

Protek-Sorb Desiccant is supplied in moisture-proof cans containing pre-determined quantities for economy and efficiency.

Medium size contains 160 grams (12 cans per case). Stock No. (890870)

Large size contains 650 grams (12 cans per case). Stock No. (890871)

## UNIQUE SOLDER POURING LADLE



Pours the metal drop by drop or in a steady stream, exactly where you want it. Positive close-to-bowl grip on the cool wood handle reduces overhang to a minimum; eliminates strain; makes it easy to direct and control the flow of molten metal. Pressed steel ladle treated so solder cannot stick. Lasts a lifetime. Wood handle inexpensive and easy to replace, only a screwdriver needed.

Dia. Bowl	Stock No.	Capacity	Weight
2 1/2"	(890763)	1/8 pint	10 oz.
3"	(890764)	1/4 pint	12 oz.
3 1/2"	(890765)	3/8 pint	14 oz.
4"	(890766)	1/2 pint	16 oz.

## METAL POURING LADLES



Catalog No.	Stock No.	Diameter Bowl In.
482	(890756)	3
1044	(890757)	4

## FLAT WIPING CLOTHS

Furnished in 16-ply herringbone and 8-ply moleskin.

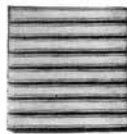

Size Inches	Herringbone Stock No.	Moleskin Stock No.
2 x2	(890778)	(890783)
2 1/2 x2 1/2	(890779)	(890784)
3 x3	(890780)	(890785)
3 1/2 x3 1/2	(890781)	(890786)
4 x4	(890782)	(890787)

## FORMED WIPING CLOTHS

Each cloth wrapped separately with size of cloth indicated on wrapper.

Williams formed flexible finished wiping cloths.



Size Inches	Herringbone Stock No.	Moleskin Stock No.
2 x2	(890788)	(890793)
2 1/2 x2 1/2	(890789)	(890794)
3 x3	(890790)	(890795)
3 1/2 x3 1/2	(890791)	(890796)
4 x4	(890792)	(890797)

## CATCH CLOTHS

Readily prepared, not formed, straight edge.

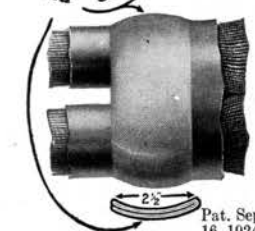

Size Inches	Herringbone Stock No.	Moleskin Stock No.
5x5	(890798)	(890803)
6x6	(890799)	(890804)
6x7	(890800)	(890805)
7x8	(890801)	(890806)
8x8	(890802)	(890807)

All wiping cloths well prepared; ready for use without breaking in.

## MELTING AND SOLDER POTS



Catalog No.	Stock No.	Size Inches
1046	(890767)	5
1047	(890768)	6
1048	(890769)	7

## LACING TWINE

Used for lacing wires into cables or lacing fanned out ends. Waxed linen; 6 and 12 Cord.

Put up in 1 lb. tubes.

Stock No.	Description
(890741)	6 Cord
(890742)	12 Cord

## MUSLIN TAPE

Muslin tape is used for wrapping cable splices before slipping lead sleeve into position. It is an unbleached muslin having a 48 x 48 weave, furnished 4 and 2 inches wide in rolls of 10 yards each.

Width Inches	Stock No.
2	(890744)
4	(890745)

## HARDWOOD DRESSERS



Made of hardwood for shaping and dressing lead sleeving, etc. Weight, 15 pounds per dozen. Stock No. (890770)

**NO. 450 WIRE SOLDER**



Wire solder is produced by an extrusion process. It can be supplied in practically any desired diameter from 1/40" to 29/64" and of any specified composition.

Made in grade 35-65. Furnished in spools of from 5 to 50 lbs. Stock No. (894189)

**DUTCH BOY WIPING BAR SOLDER**

Dutch Boy bar solder is available in several grades—each one of which is suitable for certain kinds of work and is designated by number. The grades with the lowest numerical designation contain the most tin.

**DUTCH BOY 888**



**38/62 Tin Content**

Dutch Boy 888 contains an unusually large percentage of tin for solder of this grade. It has a melting range of 363° F to 450° F. When used by plumbers for wiping it can be reduced slightly with more lead. Sold in bars weighing approximately 1 1/2 lbs. and ingots weighing 5 lbs. Stock No. (890846)

**DUTCH BOY 111**



This is the highest grade solder sold under the Dutch Boy trademark. It is guaranteed to be made of new lead and tin, carefully mixed in equal parts (50% tin and 50% lead). Its melting range is 361° F to 421° F. Dutch Boy 111 is bright, strong and free from impurities. It flows easily, covers more area and has superior adhesion. It is widely used for new roofing work and is popular among tinsmiths, manufacturers and canners. Sold in bars weighing approximately 1 1/2 lbs. Stock No. (890844)

**ALLEN SODERING LIQUID**

Standard Formula. For all-around work, for all metals save aluminum and stainless steel. 17,000 pounds to the square inch with no gumming, fumes, or corrosion. Double strength, non-evaporating. Works like lightning. Adaptable to hand, or machine soldering. Excellent for tinning the soldering copper.



Size	Stock No.	No. Per Carton
2 oz.	(890865)	24
Qt.	(894672)	3
Gal.	(890868)	1

**ALLEN SODERING SALTS**



An all around flux in convenient powder form; just add water 3 to 5 times according to metal to be soldered. Solders all metals but aluminum. Takes a quick bite and makes the solder hold on. Non acid. Comes packed in metal or glass.

Size	Stock No.	No. Per Carton
1/2 lb.	(890861)	12
1 lb.	(890862)	6
5 lb.	(890863)	1

**ALLEN SODERING PASTE**

Standard Formula. Safest soldering paste made—fast working—a convenient corrosion-free, soft form of flux. Adheres to the surface while you solder. Assures secure electrical and mechanical joints. Saves time. Triples strength of the solder. Makes solder self-fluxing. Official National Underwriters Laboratory approved listing.



Size	Stock No.	No. Per Carton
2 oz.	(890851)	24
4 oz.	(890852)	24
1/2 lb.	(890853)	12
1 lb.	(890854)	6
5 lb.	(890855)	1

**KESTER ROSIN CORE SOLDER**

For electrical and radio work. Contains a plastic rosin flux that will not corrode. Accepted standard for inside wiring and radio work.

Standard size No. 5 Kester rosin core solder is approximately 3/32 inch in diameter, running about 50 feet to the pound, in 1-pound spools. In sizes from approximately 1/4 inch to about .040 inch in diameter. Ribbon or flat type. Furnished in 1 and 5 pound spools.



1 Lb. Spool	Stock No. (890850)
5 Lb. Spool	Stock No. (894187)

**KESTER ACID CORE SOLDER**

For general soldering. Used on both new and old work. Also recommended for heavy outside electrical wiring.

Standard size No. 3 about 1/8 inch in diameter. About 30 feet per pound.

As heat is applied a scientific flux flows from tiny pockets inside hollow wire form of Kester; melting, it forms a permanent bond. Requires only heat. Furnished in 1 and 5 pound spools.



1 Lb. Spool	Stock No. (890849)
5 Lb. Spool	Stock No. (894186)

## SOLDERING COPPERS



Forged from highest grade pure copper bars. Uniformly made and perfectly balanced. Clincher type handle, positively will not loosen, and will grip firmly as long as there is any copper left. Attractively finished in Turner red. Sizes from ¼ pound to 14 pounds per pair.

½ lb.      ¾ lb.      1 lb.      1 ½ lb.      2 lbs.  
 Stock No. (890837) (890838) (890839) (890840) (890841)

## UNIQUE SOLDER COPPER HANDLE



A cool, safe solder copper hardwood handle that clings to the solder copper shank. Piano wire grip, expands and contracts with the shank as it heats and cools. Wood charring prevented. Ample air circulation over the entire length of the shank. Easy to attach—simply drive the handle over the pointed shank.

Cat. No.	Stock No.	Description
1	(890842)	For 7/32" to 3/8" shanks
2	(890843)	For 3/8" to 1/2" shanks

## NO. 302 DRIFT PLUGS

For expanding ends and smoothing out lead sleeves. Dogwood; sizes, 1, 1¼, 1½ and 2 inches.

Stock No. (890771)

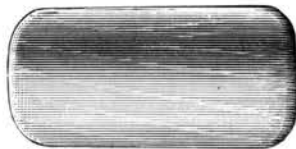

## NO. 301 TURN PINS

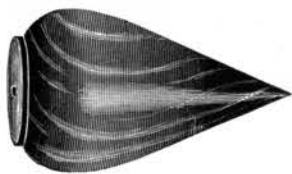

For expanding ends and smoothing out lead sleeves. Dogwood; sizes, 2¼, 2½ and 2¾ inches.

Stock No. (890772)

## NO. 304 SHAVE HOOKS



Used for scraping lead sleeves, cable ends, etc. Has removable blade.

Cat. No.	Stock No.
No. 304, with One Oval Blade	(890774)
No. 305, Oval Blade Only	(890775)
No. 305, Half Oval Blade Only	(890776)
No. 305, Triangular Blade Only	(890777)

## NO. 1515-1 KLEIN'S CABLE SHEATH Splitting Knives



Extra heavy. Knife edge is tempered and ground to a keen edge. Handle is made of leather. Weight per dozen, 12 pounds. Stock No. (890773)

## CABLE PASTERS

A 2-inch wide paper tape gummed on one side.

600 ft. per roll.  
 Stock No. (890711)

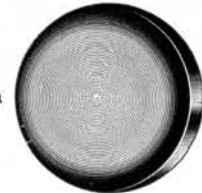

## NO. 32A—MECHANIC'S STANDARD TORCH



For general use. Generates a powerful steady blue flame 7 inches long, which can be reduced to a small flame for light work. Burner has blunt control needle, removable jet block and detachable cleaner pin. Generator is weather protected with full skirted heavy windshield securely fastened in place. Heavy gauge brass tank. Bottom filled. Automatic pump. Regularly supplied for burning gasoline. Kerosene may be used by changing jet block

and cleaner pin. Specify when ordering if kerosene is to be used. Capacity One Quart. Shipping weight, 5 pounds. Stock No. (890874)

## NO. 144A—MECHANIC'S MEDIUM TYPE TORCH



A remarkable value. The self-cleaning burner is made with blunt control valve, removable jet block and detachable cleaner pin. Produces an excellent flame of suitable volume for ordinary work. Flame smoothly regulated from high to low. Burner is protected with a light "snap-on" windshield. Heavy gauge brass tank. Bottom filled. Automatic pump. Regularly supplied for burning gasoline. Kerosene may be used by changing jet block and cleaner pin. Specify when

ordering if kerosene is to be used. Capacity One Quart. Shipping weight, 4¾ pounds. Stock No. (890875)

**NO. 500A BERNZ GASOLINE BLOW TORCHES**  
1-Quart Capacity

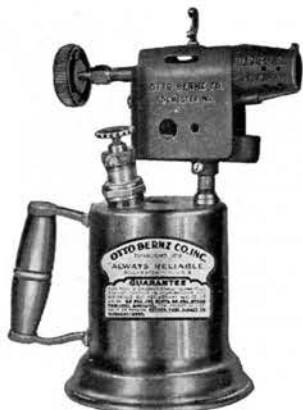

A multi-flame torch. The quality and sturdy construction of the reservoir, burner, and patented Never-Leak pump permits this torch to ignite and operate perfectly under the most severe service, regardless of weather conditions. Will burn over 500 hours without clogging.

Equipped with removable jet block and slender type self-cleaning needle which automatically cleans jet block each time it is used and prevents orifice enlargement.

Highly polished and lacquer finished. Furnished with large wind shield. Weight, 4¾ pounds. Stock No. (890877)

**NO. 87A BERNZ GASOLINE BLOW TORCHES**

Solidly built throughout, fulfilling Bernz standards in every respect, the Model 87-A is one of the most widely used torches ever manufactured.

An outstanding feature of this torch is the *self-cleaning needle*—no clogging, no loss of flame intensity, no waste of user's time.

The long-tapered, scientifically designed nozzle produces the desirable long, large, intensely hot, blue flame.

Burner is cast and machined from high-grade composition bronze, alloyed to Bernz specifications. This special bronze is highly resistant to the intense blue flame and adds considerably to its extra long life.

Close supervision of all annealing and drawing operations assures fuel-tight and leak-proof tanks. The heavy-gauge, polished cartridge brass used is the finest obtainable.

For working under adverse conditions, outdoors and in, and for all types of work, the Model 87-A has proved its leadership in dependability, economy, safety. Stock No. (894676)



**NO. 44A—COILTROL FIRE POT**

Easy to start and simple to operate. The quick detachable coil unit has a flame control device which allows the powerful flame to be varied in size and volume. A pot of metal can be rapidly melted and then, by an adjustment of the flame control valve be held at the desired temperature. This results in a saving of gasoline and metal. Designed to handle a full six inch metal pot. Regularly supplied for burning gasoline. Kerosene may be used by changing burner jet.

Capacity One Gallon. Shipping weight, 14 pounds. Stock No. (890881)

**NO. 79A BERNZ GASOLINE BLOW TORCHES**  
1-Quart Capacity



Used by public utilities, railroads, telephone companies and governmental departments.

The flame is easily controlled to any size from a small to a large, powerful, hot blue blast flame making it an ideal torch for sweat fittings and copper pipe. It will burn in any position, including up-side-down.

The large wind shield protects the generator in cold and windy weather and the slender type cleaning needle automatically cleans the removable jet block each time the torch is shut off. Highly polished, lacquer finish.

Weight, 4½ pounds. Stock No. (890876)

**NO. 32 BERNZ GASOLINE OR KEROSENE FIRE POTS**  
1-Gallon Capacity

For heavy duty, public utility and industrial use.

Combination nozzle and enclosed coil type burner is furnished which makes fire pot ideal for quickly melting solder, paraffin, lead, insulating compounds, etc. Produces a large, powerful, intensely hot, blast flame which can be closely regulated by the flame control supply valve.

Burns gasoline indefinitely and kerosene for several hundred hours without carbonizing. Burner shield is made of heavy sheet steel, and is so arranged that the user can open side to get at burner.

Furnished with pump and extra large durable 9¼-inch shield reinforced with malleable iron base and double steel ring at top. Weight, 20 pounds. Stock No. (890879)



**NO. 52 BERNZ JUMBO GASOLINE OR KEROSENE FIRE POTS**  
1-Gallon Capacity

Used by public utilities and telephone companies.

Made to operate with either gasoline or kerosene fuel by simply changing the burner block.

The flame control feature permits the size of the flame to be always under control of the operator.

Burner shield and malleable iron top plate are assembled in a complete single unit. By merely releasing the bayonet lock, this protecting housing can be quickly disengaged to permit the removal of the entire superstructure in one operation. This exposes the burner and

allows the fire pot to be used for a number of special purposes. Furnished with pump, 10-inch diameter top shield, single unit burner shield, and combination nozzle and enclosed coil type burner. Weight, 21 pounds. Stock No. (890880)



## UNIQUE GASOLINE BLOW TORCHES



**No. 0**

A safe, compact torch for the tool kit—with a hundred practical uses. A pleasing design this is certain to attract attention anywhere. Beautifully finished in red and black. Fine for use in close quarters and for sweating joints on small size copper tubing. Flame can be controlled to fine pointed jet. Burns in any position. Dimensions 1 x 6" — 1900° F. Closing

valve forces needle through orifice, cleaning it of foreign particles. Needle, orifice block and channel plugs are removable—threaded—for replacement or for cleaning of generator channels. Top filler opening. Flat tank 2 3/4" width x 5". Generator wind-shield included.

Cat. No.	Stock No.	Description
0	(894852)	1 Pint, Wt. 3 lb.

**No. 3**

A medium size flame torch for service under severe weather conditions. Used extensively by Public Utilities, Railroads, Municipalities and Electricians and mechanics whose work requires the use of a medium size flame. Long horizontal fuel veins drilled parallel with and directly under the flame. Produces a forceful blast flame—1x7" —2000° F. Flame can be regulated down to a small pointed jet. closing valve forces cleaning needle through orifice, keeping it clean and full size. Removable cleaning needle and orifice block. Removable fuel vein plugs. Fill thru bottom funnel filler.



Cat. No.	Stock No.	Description
3	(894854)	1 Quart, Wt. 4 lb.

## UNIQUE SAFETY FOLDING SHIELDS

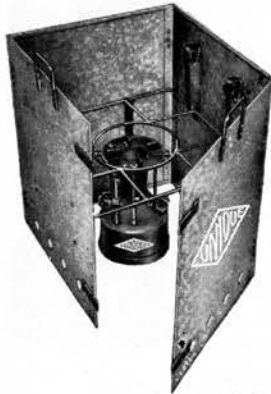

**No. 50**

The Public Utility standard shield. A 4-panel shield with welded steel grate and supporting brackets. Broad support for large pots and kettles. Made of galvanized iron. Panel edges rolled around 1/4" rod—no sharp corners. Completely rust-proof.

4 Panels fold flat for carrying and storing. Weight 27 pounds.  
Cat. No. 50 Stock No. (894850)

**No. 50-C**

Protects the public from flame and hot material. It shields the furnace from wind, affording storage space for pot, ladle and small tools. Made of galvanized iron. Panel edges rolled around 1/4" rod—no sharp corners. Completely rust-proof.

3 Panels fold flat for carrying and storing. Weight 15 pounds.  
Cat. No. 50-C Stock No. (894851)



## UNIQUE GASOLINE HEAVY DUTY PUBLIC UTILITY FURNACE



Powerful blast flame melts 50 pounds solder in 10 minutes. The finest all weather gasoline furnace. Thousands of units in daily use by Utilities, Municipalities, Railroads, heavy industries, sheet metal workers and plumbers for melting solder, paraffin compounds; for heating solder-irons.

**GENERATOR**—Fitted with replaceable orifice block. Easily cleaned thruout by removing plugs from straight lined channels. Windproof, requiring no additional protection. When the revolving shield is open the generator is in full view for priming and attention. The flame is 2000°

F., 1 1/2" x 12" length. From small jet to full blast it is finely controlled without overheating.

**TANK**—Of heavy steel with broad base. Welded thruout, shock ring protects bottom.

**TOP PLATE**—Rugged, with ample lug support for large pots and kettles. The handle locks to support solder-irons.

Cat. No.	Stock No.	Description
50	(894855)	1 1/8 Gal., Wt. 15 lb.
53	(894856)	1 Gal., Wt. 13 lb.

## UNIQUE KEROSENE HEAVY DUTY UTILITY FURNACE



Powerful blast flame melts 50 pounds solder in 10 minutes. Specify the kerosene furnace if you have trouble getting unleaded gasoline. It starts on kerosene in 4 minutes and is just as efficient in every way as a gasoline furnace. Thousands of units in daily use by Utilities, Municipalities, Railroads, Telephone and Heavy Industries, Plumbers and others, for melting solder, paraffin and compounds.

**GENERATOR**—The figure-8 generator burns kerosene without carbon formation, producing a clean flame of 2000° F. Regulating the flame volume valve for full or reduced flame automatically passes the scraper blades under orifice, clearing it of foreign particles.

**TANK**—Made of Steel, copper brazed thruout—with powerful dependable pump.

**TOP PLATE**—Rugged, with ample lug support for large pots and kettles.

Cat. No.	Stock No.	Description
55	(894857)	1 Gal., Wt. 13 lb.
58	(894858)	1 1/2 Gal., Wt. 15 lb.

**STROMBERG-CARLSON**

# Protectors

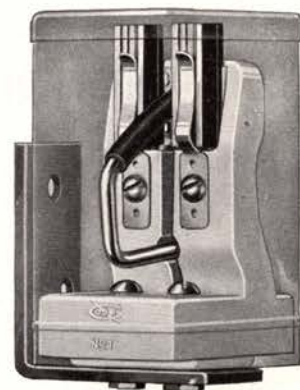

A full line of outdoor and indoor protectors, cable terminals and fuses — rugged and dependable. Stromberg-Carlson recommends only the best, thoroughly proven equipment.

CONTENTS  
SECTION Q

**PROTECTORS**

---

	Page
Cable Terminals .....	3q
Transmount Protector Unit .....	6q
Sub-Station Protectors .....	7q
Outdoor Arresters .....	8q
Telephone Station Protectors .....	9q
Connectors .....	9q
Indoor Arresters .....	10q
Terminal or Junction Boxes .....	11q
Fuses .....	13q
Distributing Frames .....	14q
Knife Switches .....	16q
Dry Batteries .....	17q
(For Storage Batteries see Section E)	

---

**Reliable Type "B"  
PROTECTED CABLE TERMINALS**

The Reliable Type B Cable Terminal is an original design, adding greatly to the convenience of installation of wiring and maintenance, made for three standard cable terminal fuses.

These terminals have a record of many years of fine performance, as they are ruggedly made of non-corrosive alloys which insure a life equal to that of the cable itself.

The B-27 cable terminal is equipped with No. 27L-5-amp. ceramic fuses.

The B-56 cable terminal is equipped with No. 56 fibre 5-amp. asbestos-lined fuses.

The B-55 cable terminal is equipped with No. 55 fibre 5-amp. asbestos-lined fuses. Supplied with 7-foot, No. 22 AWG stub. Equipped with P495 Sawtooth Discharge Blocks and P1384 Carbons.

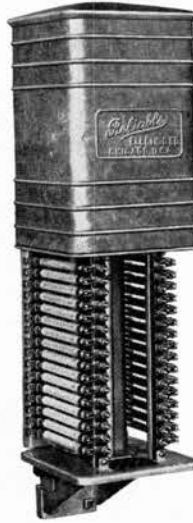

Capacity	Stock No.	Height Overall	Stub Data	Shipping Wt. Ea. (Lbs.)
11 Pair	(890551)	14 1/2"	Less Stub	11
11 Pair	(890552)	14 1/2"	With 7' Stub	14 1/2
16 Pair	(890553)	17 1/2"	Less Stub	13
16 Pair	(890554)	17 1/2"	With 7' Stub	18
26 Pair	(890555)	23 3/4"	Less Stub	18 1/2
26 Pair	(890556)	23 3/4"	With 7' Stub	24

**Reliable Type "RP"  
PROTECTED CABLE TERMINALS**

The Reliable RP is a six pair reversible protected cable terminal that is compactly designed and made of corrosion resistant aluminum alloy throughout, resulting in a very light-weight but substantial structure. Insulation is molded bakelite.

The Reliable RP is designed to meet requirements for a small protected terminal of high quality and fine workmanship. It is equipped with P495 self-cleaning saw-tooth discharge blocks. Made in two types with two standard terminal fuses.

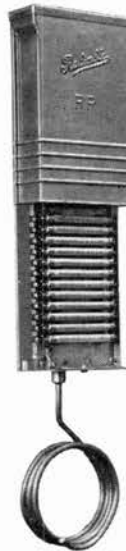

Cat. No.	Stock No.	Capacity	Height Overall	Stub Data	Fuse	Shipping Wt. (Lbs.)
RP-27	(890550)	6-pr.	11"	6'	27L 5-amp.	9 1/2
RP-56	(894900)	6-pr.	11"	6'	56 5-amp.	9 1/2

**TYPE S-6 CABLE TERMINAL  
(Protected)**

For terminating lead covered cable, providing protection and accessibility for drop wire distribution.

The bracket base, cable chamber (except zinc front), cover springs, mounting panels, as well as the hood are all steel. All parts are precision built and are heavily galvanized

The cable chamber has a removable face plate which is fastened in place with machine screws and gasket sealed. It is equipped with a self-soldering nozzle in which are placed sheet solder and flux for easy installation of cable.

Cable wires are carried from inside of cable chamber through hollow brass studs and soldered to the tinned end of the stud. Each pair of cable studs is set in individual rubber blocks, securely fastened into the wall of the cable chamber.

Spring phosphor bronze fuse clips hold the fuses under constant tension. Fuses can be easily removed and replaced. Perfect conductivity is secured regardless of vibration or moisture.

The S-6 is equipped with Cook A-7 wood fuses of 5 amperes, which blow at rating. The lightning arresters consist of Tru-Gap Dischargers and hard grooved carbons which are held under permanent tension by separate phosphor bronze springs.

On the drop side, both screw and washer and solder connections are provided.

All current carrying parts are insulated with hard rubber. Moisture-proof insulation with knockouts for drop wires is provided where drops pass through the metal base.

The hood is made of sheet steel, formed, assembled and then hot galvanized. A hood guide spring holds the hood at any desired height. Furnished with cable stud attached when so ordered.

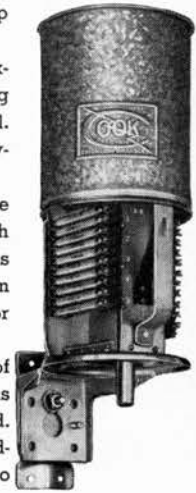

**Terminal With Stub**

Diameter 9 inches.				
Cat. No.	Stock No.	Capacity	Height In.	Ship. Wt. Pounds
112-1706	(890483)	11 pair	14	27
112-1709	(890485)	16 pair	17 1/2	30
112-1712	(890487)	26 pair	26 1/2	38
112-1715	(890489)	51 pair	39 1/2	82
112-1716	(890491)	102 pair	79	164

**Terminal Less Stub**

Diameter 9 inches.				
Cat. No.	Stock No.	Capacity	Height In.	Ship. Wt. Pounds
112-1700	(890482)	11 pair	14	16
112-1701	(890484)	16 pair	17 1/2	19
112-1702	(890486)	26 pair	26 1/2	27
112-1703	(890488)	51 pair	39 1/2	65
112-1704	(890490)	102 pair	79	130

**GENERAL INDEX**

A complete alphabetical index with cross references for all the products shown in this section or any of the other sections will be found in the center of this catalog.

## Reliable Type "RU" UNPROTECTED CABLE TERMINALS



This reversible unprotected cable terminal, with ribbed aluminum alloy sliding cover, protects terminal connections from weather and permits installation with stub at top or bottom. Chamber filled and sealed with Reliable Cable Compound. when supplied with stub.

The flat fanning plate simplifies wiring, and in combination with a cover which surrounds the wires at the back, makes an unusually weatherproof terminal, and also gives the lineman more convenient working space.

Detachable mounting bracket simplifies installation.

Equipped with gravity catches to hold cover in raised position—guide rings for jumpers—aluminum cover chain. Silicon bronze screws—free from season cracking—are mounted on bosses to increase surface leakage distances, and locked in panels of highest grade molded insulation.

Capacity	Stock No.	Height Overall	Stub Data	Shipping Wt. Ea. (Lbs.)
6 Pair	(890559)	11"	Less Stub	6½
6 Pair	(890560)	11"	With 6' Stub	8½
11 Pair	(890561)	11"	Less Stub	7
11 Pair	(890562)	11"	With 6' Stub	10
16 Pair	(890563)	12½"	Less Stub	9
16 Pair	(890564)	12½"	With 6' Stub	12½
26 Pair	(890565)	16"	Less Stub	16
26 Pair	(890566)	16"	With 6' Stub	25

Furnished with 6 ft. of No. 22 AWG double wrap paper insulated cable unless otherwise specified.



## Reliable Type "GR" UNPROTECTED CABLE TERMINALS

The GR is a cast aluminum alloy unprotected cable terminal. It is provided with a gravity cover that is balanced to shut tight. Equipped with porcelain faceplate, grooved in back to prevent turning of binding posts. Silicon bronze screws. Chamber filled and sealed with Reliable Cable Compound.

Cover and cable of corrosion resistant aluminum alloy.

Capacity	Stock No.	Height Overall	Stub Data	Shipping Wt. Ea. (Lbs.)
11 Pair	(890542)	8½"	Less Stub	5½
11 Pair	(890543)	8½"	With 6' Stub	9½
16 Pair	(890544)	11"	Less Stub	9
16 Pair	(890545)	11"	With 6' Stub	13
26 Pair	(890546)	15½"	Less Stub	12½
26 Pair	(890547)	15½"	With 6' Stub	16½

Furnished with 6-foot, No. 22 AWG stub, unless otherwise specified. When ordering, specify whether required with cable stub at top or bottom.

## TYPE SX CABLE TERMINAL (Protected)

A small terminal to be used where maximum distribution is four to six pairs and where protection is required.

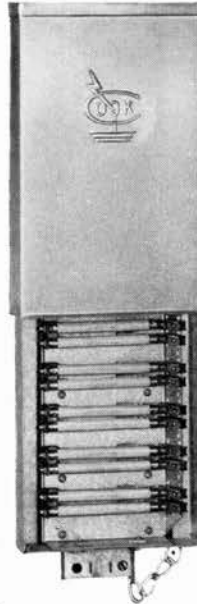

The Type SX Cable Terminal though of small capacity combines all of the construction and installation features found in larger terminals. The cable enters the Type SX through a well in which the solder is puddled so that a strong, moisture-proof connection is made. A patented metal strap on the mounting bracket clamps the cable to prevent injury at the cable joint.

Cable wires are carried from inside the cable chamber through hollow stubs and soldered to the tinned end of the stub. Each pair of cable stubs are set in individual hard rubber blocks securely fastened into the metal plate of the cable chamber. This method of construction insures high insulation and a moisture-proof seal for the cable.

Fuses are held under constant tension in phosphor bronze fuse clips thoroughly insulated by hard rubber. Fuses may be easily removed and replaced. Heavy bronze springs insure positive, permanent pressure between lightning arresters and ground plate.

Protection consists of A-7 fuses, which blow at 5 amperes, Tru Gap Dischargers, and carbons. Arresters ground on a copper strip. Tru Gap Dischargers do not ground the line.

Screw and washer and solder connections are provided. Drops pass through a patented, adjustable opening in the base of the terminal.

The SX is regularly equipped with a mounting bracket. When desired a detachable mounting bracket will be furnished at no extra charge.

Furnished with cable stub attached when so ordered.

The cable chamber and bracket of the Type SX are made of steel, formed, assembled and hot galvanized. The hood fastens to the terminal with a strong chain.

### Type SX Cable Terminal 4 Pairs, Complete

Cat. No.	Stock No.	Height In.	Width In.	Terminal Less Stub	
				Depth Inches	Ship. Wt. Lb.
492-9000	(890502)	15¼	7¾	3½	11

Cat. No.	Stock No.	Height In.	Width In.	Terminal With Stub	
				Depth Inches	Ship. Wt. Lb.
492-9010	(890507)	15¼	7¾	3½	20

### COOK NO. 452-500 SOCKET WRENCH



For ¾" nut, on various Cook protectors.

Stock No. (890541)

**"RUG" UNDERGROUND CABLE TERMINAL**

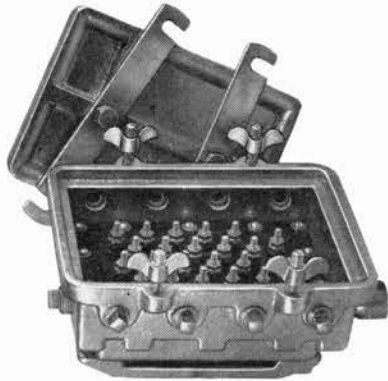

The reversible underground gastight terminal has a rugged cast iron housing and cover thoroughly hot galvanized. Equipped with brass plugs which may be removed to insert solder dipped brass stuffing boxes. Reliable stuffing boxes are available.

Detachable mounting bracket — reversible — light weight — bakelite face plate with locked silicon bronze binding posts.

Capacity	Stock No.	Height Overall	Stub Data	Shipping Wt. Ea. (Lbs.)
11 Pair	(890572)	8 1/4"	With 6' Stub	22
11 Pair	(890573)	8 1/4"	With 15' Stub	26

**TYPE XB CABLE TERMINAL**

The Type XB Unprotected Cable Terminal embodies many important advancements in construction, wiring features, maintenance savings and insulation characteristics the more important of which are detailed as follows:

A patented bakelite face plate and insulating fanning strip moulded in one piece. The raised stud mountings eliminate surface leakage.

Sturdy, non-corroding Everdur studs have tinned solder shoulders. Studs cannot twist off and are firmly embedded in the bakelite mounting plate, correctly positioned for convenient wiring.

Patented cable entrance and cable holding sleeve provide secure and tight cable joint.

Compound is completely filled by an exclusive moisture proofing process that insures against shorts and grounds by permanently positioning the cable pairs.

Heavy reversible zinc hood permits mounting with stub from either top or bottom.

Terminals are furnished either with or without 6 ft., 22 gauge cable stub.

Catalog No.	Stock No.	Description	Ht. In.	Width In.	Net Wt.
452-3502	(890492)	6 pair less stub	9	6	5
452-3506	(890493)	6 pair with stub	9	6	8
452-3503	(890494)	11 pair less stub	12 1/2	7	7
452-3509	(890495)	11 pair with stub	12 1/2	7	15
452-3504	(890496)	16 pair less stub	12 1/2	7	7
452-3512	(890497)	16 pair with stub	12 1/2	7	15
452-3505	(890498)	26 pair less stub	15 1/4	7 3/8	11
452-3515	(890499)	26 pair with stub	15 1/4	7 3/8	22
452-283	(890500)	Hood, 11 or 16 pr.	---	---	---
452-189	(890501)	Hood, 26 pair	---	---	---

**TYPE UX CABLE TERMINAL  
(Underground Unprotected)**

For mounting in manholes for termination and distribution of underground cable systems.

Designed to facilitate installation and service in manhole termination and distribution of underground cable systems, the Type UX Cable Terminal combines many features which have made it popular with telephone men everywhere.

The lateral cable enters through a well in the cable chamber into which solder is puddled so that a strong moisture-proof connection is made. The terminal may be mounted with cable stub out of top or bottom.

The terminal provides for service outlets. These outlets in the sides of the terminal are sealed with a brass pipe plug having a 3/8" pipe thread. Lead sheath of instrument distribution cables are terminated in heavy brass stuffing boxes set in the service outlets. Stuffing boxes are made to accommodate lead cable of 3/8" diameter and are sold separate from the terminal. The number required should be stated.

The face plate is made of a single piece of molded bakelite. Bosses moulded on the face of the bakelite increase the surface distance between stubs.

Heavy studs with square heads are set in the bakelite so they cannot turn. Terminal is furnished with or without cable stub attached.

The cover of the Type UX fits the box so as to compress a gasket and make a water tight seal.

Catalog No.	Stock No.	Description	Ht. In.	Width In.	Net Wt.
512-3702	(890508)	6 pair less stub	7 3/4	6	12
512-3703	(890509)	6 pair with stub	7 3/4	6	20
512-3700	(890510)	11 pair less stub	11 1/2	6 1/2	20
512-3701	(890511)	11 pair with stub	11 1/2	6 1/2	30
512-3705	(890512)	16 pair less stub	11 1/2	6 1/2	22
512-3706	(890513)	16 pair with stub	11 1/2	6 1/2	31
452-3750	(890514)	Stuffing Boxes	---	---	---

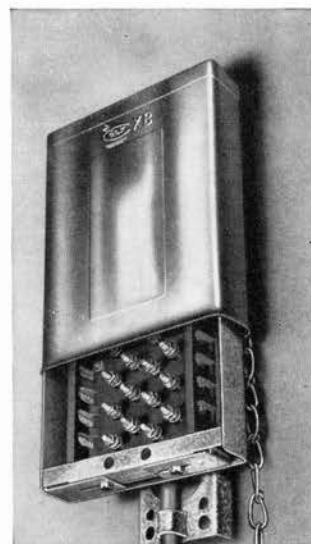

Type XB



Type UX

## TYPE S-20 POLE CABLE TERMINAL AND PROTECTOR MOUNTING

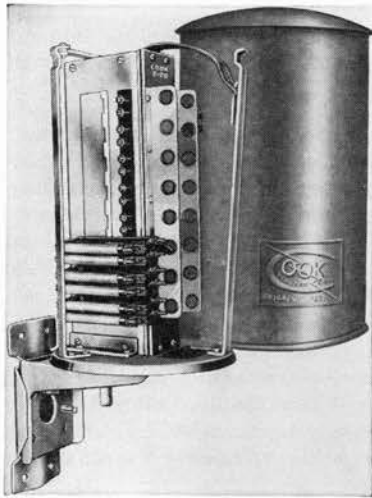

The Type S-20 Pole Cable Terminal and Protector Mounting is already in wide use as a combined protected and unprotected all steel cable terminal. As part of the Trans-Mount System, the S-20, like the other units, offers maximum economy because Type H Protector Mounts may be installed as required.

The self soldering nozzle of the S-20 is located close to the pole to bring the cable behind the subscribers' drops. The mounting base is open at the back adjacent to the pole to prevent accumulations of ice, dirt or moisture. A separate mounting bracket shaped to fit the pole provides easy installation without gaining the pole. Drop wires enter the terminal through individual insulating knockout holes.

In order to insure orderly arrangement of drop wires, metal fanning strips with insulating bushings are mounted in front of the cable chamber. All metal parts are non-corrosive. The gasketed sealing plate of the cable chamber is easily removed from the front.

### Terminal Less Stub

Cat. No.	Stock No.	Capacity	Dimensions	Ship. Wt.
506-1800	(890515)	6 pairs	12"x9"	11 lbs.
506-1820	(890517)	11 pairs	15½"x9"	15 lbs.
506-1840	(890519)	16 pairs	19"x9"	18 lbs.
506-1870	(890521)	26 pairs	28"x9"	23 lbs.
506-1896	(894614)	51 pairs	???	??

### Terminal With Stub

506-1805	(890516)	6 pairs	12"x9"	18 lbs.
506-1825	(890518)	11 pairs	15½"x9"	23 lbs.
506-1845	(890520)	16 pairs	19"x9"	28 lbs.
506-1875	(890522)	26 pairs	28"x9"	35 lbs.
506-1895	(894615)	51 pairs	???	??

## TRANSMOUNT PROTECTOR UNITS

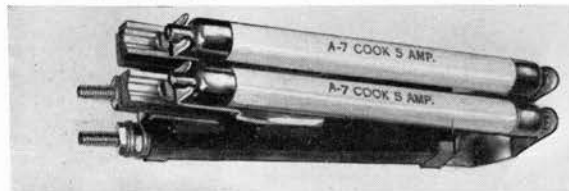

Catalog No.	Stock No.	Type	Fuse
506-1850	(890186)	H-20-7	A-7 Wood
506-1851	(890187)	H-20-9	A-9 Lavite

## TYPE UA-20 AERIAL TO UNDERGROUND TERMINAL AND PROTECTOR MOUNTING



Unique cross connection features insure high efficiency and maximum utility of cable. Subscribers' drops can be taken out of the terminal without disturbing the protection and testing features. Protection is provided by the Dual Gap H-20 Trans-Mount Protector Units.

The UA-20 Cable Terminal is used at the junction of aerial and underground cables.

The UA-20 closely resembles the design of the S-20 Pole Cable Terminal. The UA-20 is equipped with two entering nozzles and the cable chamber is equipped with terminating stubs for each cable. Protection is provided by the Dual Gap H-20 Protector Unit which connects each aerial cable pair with its adjacent underground pair.

By removing the fuses the overhead and underground cables are quickly disconnected, permitting testing in either direction. Special test clips with fuse clip adapters and cords are furnished. Service is reestablished by re-inserting the fuses into the heavy spring clips, which insure constant electrical contact and no resistance loss, an important feature in toll cable transmission.

### Terminal Less Stub

Cat. No.	Stock No.	Capacity	Ship. Wt.
506-1900	(894749)	11 pair	17 lbs.
506-1902	(894751)	16 pair	22 lbs.
506-1904	(894753)	26 pair	28 lbs.
506-1906	(894755)	51 pair	50 lbs.
506-1866	(894757)	H-20-20 Protector Mounting with A-7 Fuse, for use with any UA-20 Terminal.	

### Terminal With Stub

506-1901	(894750)	11 pair	31 lbs.
506-1903	(894752)	16 pair	35 lbs.
506-1905	(894754)	26 pair	42 lbs.
506-1907	(894756)	51 pair	84 lbs.

**OUTDOOR STATION PROTECTORS**

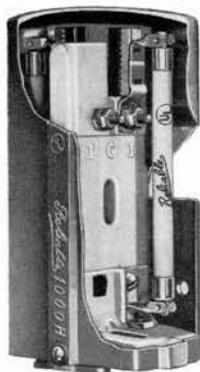

Reliable No. 1000 protectors are listed as standard by Underwriters' Laboratories. Their severe tests are sponsored by the National Board of Fire Underwriters in the interest of fire prevention.

The No. 1000 outdoor station protector is made of the best possible materials—special low absorption porcelain, heavy silicon bronze binding posts and nuts, phosphor bronze clips and rugged aluminum cover and bracket. Its patented design, with one fuse on each side of a vertical porcelain section, affords plenty of room for easy installation of all wires. Beveled washers add to this convenience.

Equipped with P495 sawtooth discharge blocks and P197 carbons. Shipping weight 2 lbs.

Catalog No.	Stock No.	Fuse Am- No. peres	Fuse	Size in Inches
*1000	(890204)	77L 7	Fibre	5 3/4 x 3 1/2 x 2 1/4
*1000H	(890207)	27L 7	Ceramic	6 1/2 x 3 1/2 x 2 1/4
1000F	(890209)	55 7	Ceramic	6 1/2 x 3 1/2 x 2 1/4

**TYPE O SUB-STATION PROTECTORS**

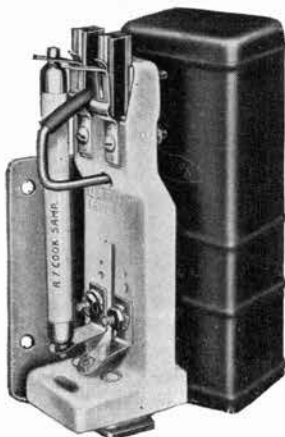

The Type O single circuit protector, equipped with one pair of fuses and one pair of high potential dischargers are unexcelled for both indoor and outdoor use.

The body of the Type O is a single piece of heavy white glazed, low absorbent porcelain, designed to prevent surface leakage. Fuse and lightning arrester clips are of phosphor bronze securely fastened to the porcelain body by Everdur bolts. The lightning arresters consist of two Tru Gap dischargers and two flat carbons mounted on a copper ground strip. Cook standard carbons or Cook unit dischargers may also be used.

The Type O sub-station protector is made for various types and lengths of fuses. Fuses are 5 amperes and blow at rating. When specified, fuses of either higher or lower rating will be furnished.

A non-corrosive Everdur metal hood fits tightly to the sides

**TYPE O SUB-STATION PROTECTOR (Cont.)**

and bottom of the porcelain body, the galvanized bracket acting as a stop.

Type O protectors are also furnished with a round hole in the porcelain to take small size lead covered, rubber insulated cable for underground distribution.

**TYPE R SUB-STATION PROTECTOR**

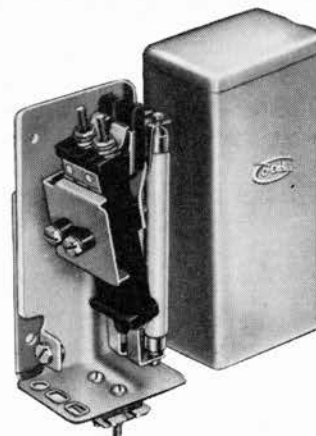

The Type R Sub-Station Protector Mounting for outside mounting on post, wall, etc., is equipped with bracket and heavy zinc weatherproof hood. The Type R represents something new in sub-station protector design. The heavy steel bracket which replaces the outmoded, brittle porcelain member will appeal to those telephone engineers and maintenance men who want equipment that can take quick, rough handling and subscriber abuse without the danger of breakage.

The high insulating value and great tensile strength of the quality moulded bakelite used in the Type H Mount gives the Type R Sub-Station Protector Mounting higher resistance to breakage from the shocks of severe electrical discharges, and greater physical strength and durability.

Type R Sub-Station Protector Mountings are equipped with heavy studs for connecting drop wires and ground. All structural parts and the hood and bracket are grounded. The Type R uses the Type H Protector Mounts thus gaining all of the advantages of the Type H features.

**TYPE R SUB-STATION PROTECTOR MOUNTING**

**Less Protector Units**

Catalog No.	Stock No.	Type	Dimensions	Net Wt.
516-1	(890184)	Outdoor	7 1/2 x 2 1/2 x 3	1 3/4 Lb.

**Type O Sub-Station Protectors**

Cat. No.	Stock No.	Description	Length In.	Width In.	Depth In.	Net Wt. Lb.
471-1581	(890177)	0-7 complete with A-7 Wood fuses	6 1/4	2 1/4	1 3/4	2
472-1582	(890178)	0-9 complete with A-9 Lavite fuses	6 1/4	2 1/4	1 3/4	2
473-1583	(890179)	0-12 complete with A-12 Lavite fuses	4 1/2	2 1/4	1 3/4	1 1/2
474-1584	(890180)	0-16 complete with A-16 Wood fuses	6 1/4	2 1/4	1 3/4	2
481-1585	(890181)	0-44 complete with A-44 Wood fuses	4 1/2	2 1/4	1 3/4	1 1/2
475-1586	(890182)	0-52 complete with A-52 Fibre fuses	6 1/4	2 1/4	1 3/4	2

## Reliable No. 222 OUTDOOR ARRESTERS

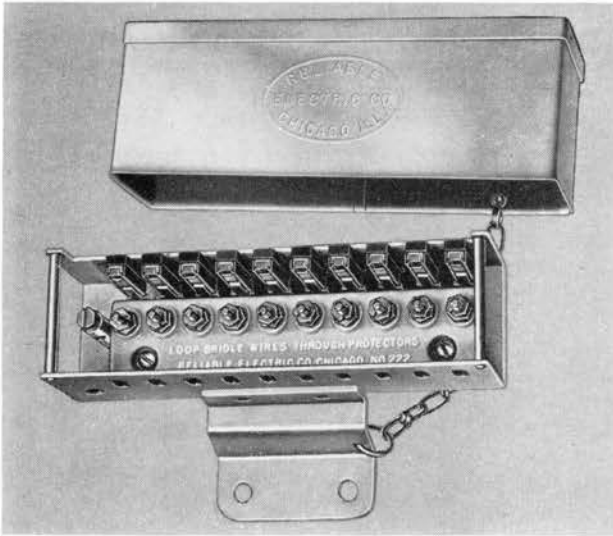

The No. 222 ten wire crossarm arrester effectively drains static from exposed lines. It is recommended for use with unprotected cable terminals where open wire or drop wire leads are too long to be left unprotected. Entrance slots at the base of this outdoor arrester permit bridle wires to loop through on the way to the terminal. Equipped with P495 Discharge Blocks and P663 Carbons. Size 8¼" x 2¾" x 4½". Shipping weight 4 lbs.

Stock No. (890212)

## Reliable 402RR TWO WIRE CROSSARM ARRESTER



The No. 402RR dry spot lightning arrester is equipped with self-cleaning sawtooth discharge blocks which drain the line of static without danger of leaving an accidental ground on the line.

Equipped with P495 Discharge Blocks and P1384 Carbons. Size 8½" x 3" x 3". Shipping weight 2 lbs.

Stock No. (890214)

## Reliable P-495 SAWTOOTH DISCHARGE BLOCKS



These discharge blocks are ideal for use in station protectors and arresters, crossarm arresters, protected cable terminals and central office protectors. Listed as standard by Underwriters' Laboratories. Made with high grade steatite ceramic insulators and low resistance, corrosion resisting metal sawtooth dischargers. These discharge units will assure adequate long term protection with the minimum of maintenance.

Reliable P-495 Stock No. (890262)

## TYPE 7 HIGH POTENTIAL LIGHTNING ARRESTER Outdoor Pole Type Arrester Ten Wire Capacity

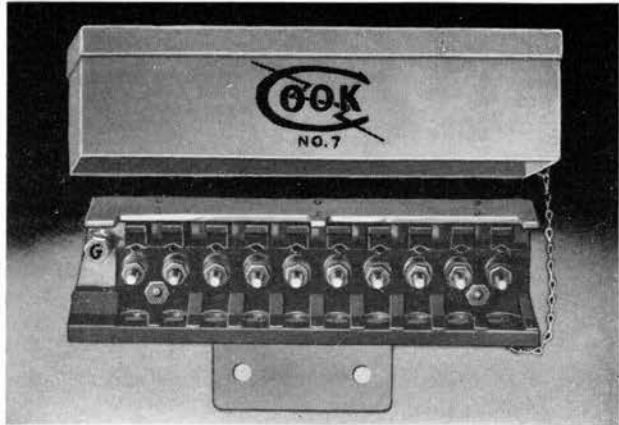

The Type 7 High Potential Lightning Arrester provides lightning protection and static drain for 5 pairs of open-wire circuits. This arrester should also be used for the protection of drop wires and cables terminating in unprotected cable terminals where atmospheric conditions require constant static drain. Insulation and fanning strip are single-piece moulded Bakelite. Non-corrosive metal hood, Everdur studs, and galvanized mounting bracket assure satisfactory service and long life. Phosphor bronze springs clips accommodate non-grounding, Tru Gap lightning dischargers.

### Type 7 Lightning Arrester Complete With Dischargers

Cat No.	Description	Length Inches	Width Inches	Depth In.	Net Wt. Lb.
371-2200	No. 7 Arrester	7½	2	5	3

Stock No. (890192)

## TYPE 1 HIGH POTENTIAL LIGHTNING ARRESTER For Station Protection or Static Drain

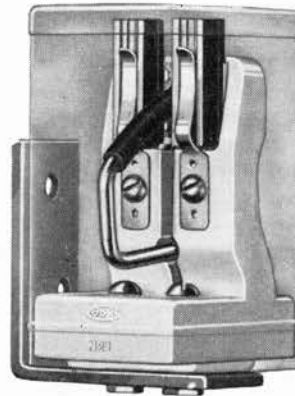

The Type 1 High Potential Lightning Arrester can be used for either station protection or static drain on long rural circuits where lightning is the principal hazard. The long life and dependable service rendered by this protector is insured by patented non-grounding Tru Gap dischargers, grounded non-corrosive Everdur cover, and heavily galvanized mounting bracket. This device is also recommended as an adjunct to the line wire side of the sub-station protector for grounding heavy potentials at the pole in areas where power crosses, joint pole occupancy, and heavy discharges present constant hazards.

station protector for grounding heavy potentials at the pole in areas where power crosses, joint pole occupancy, and heavy discharges present constant hazards.

### Type 1 Lightning Arresters With Dischargers

Cat No.	Stock No.	Length In.	Width In.	Depth In.	Net Wt. Lb.
501-7800	(890188)	3½	2½	2½	¾

**TELEPHONE STATION PROTECTORS**  
**Equipped with Adjustable P162 Sawtooth**  
**Discharge Plates and P164 Carbons**



**NO. 997-B**

The Reliable No. 997-B Station Protector is mounted in a glazed porcelain weather-proof housing. It has adjustable sawtooth metal discharge plates normally spaced .004 from the carbon ground.

Adjustable P-162 sawtooth discharge plates and 164 carbons.  
 Size of Protector: 8 7/8" x 3 3/4" x 2 5/8".

Cat. No.	Stock No.	Fuse No.	Fuse	Amperes	Ship. Wt. Ea. Lb.
997B	(894057)	95L	Ceramic	3	4

**NO. 975**

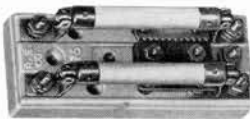

The Reliable No. 975 Arrester is mounted on glazed porcelain base and has adjustable sawtooth metal discharge plates spaced .004" from carbon ground.

Cat. No.	Stock No.	Description	Fuse No.	Fuse	Amp.	Size Inches	Ship. Wt. Ea. (Lbs.)
975	(890195)	(With Round Cover)	Round Ceramic	Two	3	5x2x2 9/16	1 1/2

**NO. 976**

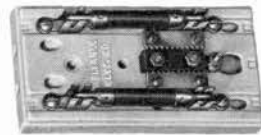

The Reliable No. 976 Indoor Protector is mounted on a glazed porcelain base and has adjustable sawtooth metal discharge plates spaced .004 from carbon ground.

Cat. No.	Stock No.	Description	Fuse No.	Fuse	Amp.	Size Inches	Ship. Wt. Ea. (Lbs.)
*976	(890201)	(With Round Cover)	Round Fibre	Two	7	6x3x2 1/8	2 1/2

\*Listed as standard by Underwriters Laboratories.

**NO. 998-C**



The Reliable No. 998-C Arrester is mounted on a glazed porcelain base and has adjustable sawtooth metal discharge plates spaced .004 from carbon ground.

Cat. No.	Stock No.	Description	Fuse No.	Fuse	Amp.	Size Inches	Ship. Wt. Ea. (Lbs.)
*998C	(890200)	(With Round Cover)	Round Ceramic	Two	7	7 1/2 x 3 1/2 x 2 9/16	3

\*Listed as standard by Underwriters Laboratories.

**RELIABLE CONNECTING BLOCKS**

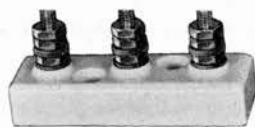

Reliable Connecting Blocks are used for connecting inside and outside wires where telephone protectors are mounted outdoors; also used for extension connections. Heavy bronze posts spun

over and mounted on special low absorption porcelain.

No. of Binding Posts	Stock No.	Size—Inches	Std. Pkg.	Shipping Wt. per C
2	(890210)	1x2x1 3/8	20	50
3	(890211)	1x3x1 3/8	20	75

**TESTERM DROP WIRE CONNECTOR**

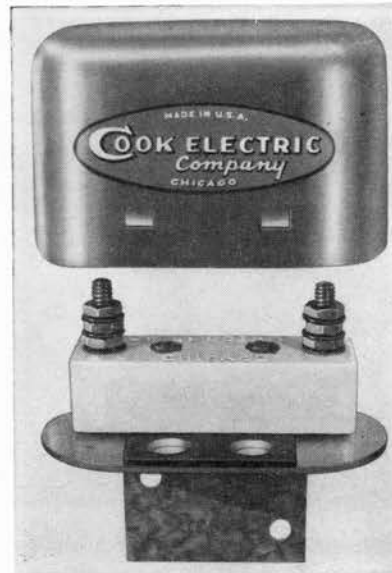

The Cook Testerm is used to connect subscriber drops to open wire. Mounted on the cross-arm, it provides a dry-spot connection for terminating drop wires. Tie wires terminate on two 12-24 studs set in porcelain. Drop wires attached to same studs permit testing without opening a taped connector. All metal parts are rust-proofed, and the one piece drawn metal hood is hot galvanized.

Catalog No. 563-1 Stock No. (894859)

**TYPE OBW BURIED WIRE TERMINAL**



An unprotected, weatherproof terminal for terminating, testing and distributing buried wire. Capacity 1, 2 or 3 pairs.

Box and bracket is made of rust resisting steel, formed, spot welded together and hot galvanized.

Base is perforated for 1/2" pipe, through which the buried wires enter and leave the terminal. Aerial drops are taken from the terminal through two insulated openings in the base.

Insulation is of hard rubber, securely fastened to the sides of the box. Heavy metal inserts moulded in the rubber provide a base for the screw and washer connections.

A thin metal tie between the screw connections may be easily cut with a penknife as required. Cover is of Everdur metal.

Height In.	Depth In.	Width In.	Ship. Wt.
8	2	2 1/2	1 lb.

Cat. No. 514-001 Stock No. (890191)

## INDOOR ARRESTERS

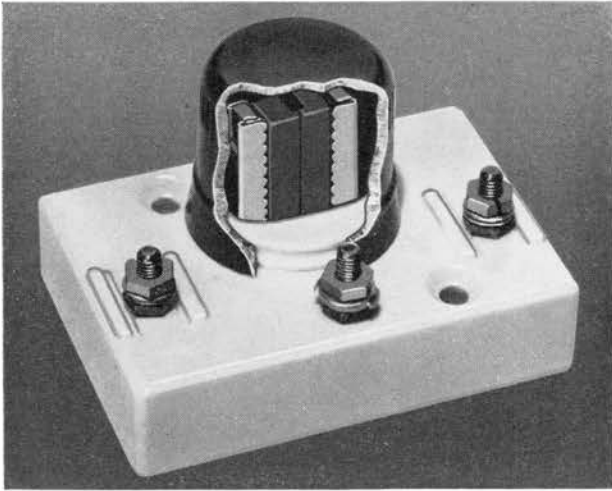

The Reliable No. 977AA Indoor Arrester is equipped with air gaps for protection against static where crosses with electric circuits are not likely to occur.

Cat. No.	Stock No.	Description	Size Inches	Ship. Wt. Ea. (Lbs.)
977AA	(890197)		3 5/8 x 2 1/2 x 2 5/16	1

## RELIABLE NO. 975-B

### INDIVIDUAL STATION PROTECTOR

The Reliable No. 975-B Individual Station Protector has adjustable sawtooth metal discharge plates spaced .004" from the carbon ground.



Cat. No.	Stock No.	Description	Size	Wt. Each
975B	(890198)	(Without Cover)	5x2x1 1/2	1
975B	(890199)	(With Cover)	5x2x1 1/2	1 1/4

## INDOOR STATION PROTECTORS

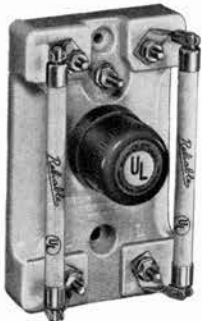

The 955 Series of station protectors have all the features of the well-known Reliable Protectors. This protector is a one piece design which simplifies mounting and installation. The protector is neat and compact, with connections easily accessible for installation.

Reliable Nos. 955 and 955A protectors are listed as standard by Underwriters' Laboratories. Their severe tests are sponsored by the National Board of Fire Underwriters in the interest of fire prevention.

Cat. No.	Stock No.	Fuse No.	Amp.	Type Fuse	Size Inches	Shipping Wt. (Lb.)
955	(890202)	Two 55	7	Round Fibre	3 1/2 x 5 9/16	2 1/4
955A	(890203)	Two 77L	7	Round Ceramic	3 1/2 x 5 9/16	2 1/4

## TYPE NO. 2 LIGHTNING ARRESTER

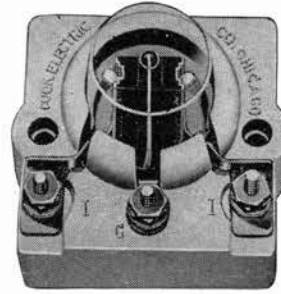

An indoor arrester, consisting of a solid piece of glazed porcelain fitted with Everdur binding posts, nuts, washers, and phosphor bronze springs.

Lightning arresters are non-grounding Tru Gap Dischargers and plain ground carbons, set in a recess and covered with a ventilated metal cap.

## No. 2 Lightning Arrester

Width 3 inches; Length 2 3/4 inches; Depth 2 inches; Net Wt. 3/4 lb.

Cat. No.	Stock No.	Description
244-1606	(890189)	With Discharger
244-1607	(890190)	With Carbons

## LIGHTNING ARRESTER REPLACEMENTS

### Lightning Arresters and Dielectrics

Cat. No.	Stock No.	Description
41-2001	(890264)	3 Carbon block grooved
41-11	(890265)	2 Acetate Dielectric .005" thick
41-12	(890266)	Acetate Dielectric .007" thick
41-8	(890267)	Mica Dielectric .007" thick
41-53	(890268)	Mica Dielectric .010" thick
41-3001	(890269)	1 Carbon block plain
41-1281	(890270)	Carbon block for No. 100 protector

## TYPE B-7 SUB-STATION PROTECTOR

To be mounted indoors

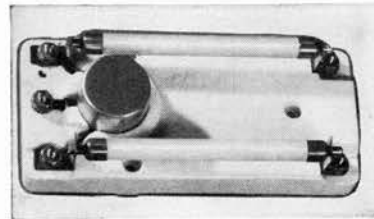

Base is of heavy porcelain, highly glazed, on which are mounted phosphor bronze contact springs. Screws, nuts, and washers are of Everdur.

Lightning arresters consist of two non-grounding Tru Gap Dischargers and two flat carbons set in a well in the porcelain and covered with a vented metal cap. Equipped with A-9, 3 ampere fuses.

Cat. No.	Stock No.	Length In.	Width In.	Depth In.	Net Wt. Lb.
115-1530	(890183)	6 3/4	3	2	1 1/2

**RELIABLE BUILDING TERMINAL BOXES**

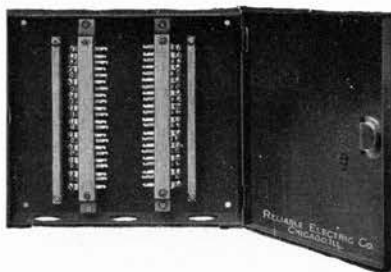

Reliable Building Terminal Boxes are provided with numerous knockouts at top and bottom. They are also provided with fanning strips and terminal strips having screw binding posts for distributing wires, and soldering terminals for cable wires. They are easy to cable.

**Type E equipped with Type E Terminal Strips**

Cat. No.	Stock No.	Pairs Per Row	Rows of Term'ls	Width Inches	Height Inches	Depth Inches	Ship. Wt. (Lbs.) Ea.
E 11	(891027)	11	1	6	10	4	7
E 16	(891028)	16	1	6	16	4	8
E 22	(891029)	11	2	12	12	4	10
E 26	(891030)	13	2	12	16	4	14
E 32	(891031)	16	2	12	16	4	15
E 52	(891032)	26	2	12	20	4	19
E104	(891033)	52	2	12	40	4	34
E208	(891034)	52	4	24	48	4	125

**Type EC for cross connecting cables.**

Equipped with jumper rings and space for jumper wires

Cat. No.	Stock No.	Pairs Per Row	Rows of Term'ls	Width Inches	Height Inches	Depth Inches	Ship. Wt. (Lbs.) Ea.
EC 52	(891038)	26	2	12	20	4	16
EC104	(891039)	26	4	24	24	4	45
EC208	(891040)	52	4	24	48	4	125

**Type L equipped with Type L Terminal Strips**

Cat. No.	Stock No.	Pairs Per Row	Rows of Term'ls	Width Inches	Height Inches	Depth Inches	Ship. Wt. (Lbs.) Ea.
L11	(891035)	5 1/2	2	12	12	4	9
L16	(891036)	8	2	12	16	4	11 1/2
L26	(891037)	13	2	12	20	4	16
L52	(894768)	26	2	12	40	4	20

**TERMINAL STRIPS**

**Reliable Type "E"**

Screw binding posts with soldering terminals embedded in hard maple mounted on phenolic base plates.



Cat. No.	Stock No.	Length Inches	Shipping Wt. (Lbs.)
E-11PR	(891044)	9 5/16	1/2
E-13PR	(891045)	10 7/16	3/4
E-16PR	(891046)	12 7/16	3/4
E-22PR	(891047)	17 1/8	1
E-26PR	(891048)	19 5/8	1
E-32PR	(891049)	23 1/8	1 1/2
E-52PR	(891050)	37 3/4	2 1/2

**Reliable Type "L"**

Twin screw binding posts with one soldering terminal mounted on molded plastic with treated maple base strip.



Cat. No.	Stock No.	Length Inches	Shipping Wt. (Lbs.)
L- 5 1/2 PR	(891051)	8 3/8	1/2
L- 8PR	(891052)	11 1/2	3/4
L-11PR	(891053)	15 1/4	1 1/2
L-13PR	(891054)	17 3/4	1 1/4
L-16PR	(891055)	21 1/2	1 1/2
L-26PR	(891056)	34	2 1/2

**Reliable Type "T"**

Terminal strips are equipped with soldering terminals embedded in phenolic retaining strips and mounted on a phenolic base, made with 1, 2, 3, or 4 rows of terminals of 20 or 26 terminals per row.



Cat. No.	Stock No.	Length Inches	Shipping Wt. (Lbs.)
T-1x20	(891057)	9 3/4	1/2
T-1x26	(891058)	9 3/4	3/4
T-2x20	(891059)	9 3/4	1
T-2x26	(891060)	9 3/4	1 1/4
T-3x20	(891060)	9 3/4	1 1/4
T-4x26	(891060)	9 3/4	1 1/4

Code No. denotes type (T) number of Rows (1) Terminals per row (20) T-1x20.

**TRU-GAP DISCHARGER**

A lightning arrester for use on circuits where it is not desirable to ground the line during continuous discharges.

Cook Tru-Gap is of rugged construction, air gap spacing of .075" is extremely accurate, and minimizes maintenance expense. The discharger is used with a carbon block.

A heavy bronze discharge blade is inserted into a moulded Bakelite block, the size of an ordinary carbon. On the top of this Bakelite block a bronze cap is anchored to the discharge blade. The discharge surfaces are completely inclosed so that no dust or conductor particles can accumulate.

The Cook Tru-Gaps are designed for use in Pole Cable Terminals, sub-station Protectors, Lightning Arresters, and heavy duty remote or unattended Central Office protection.

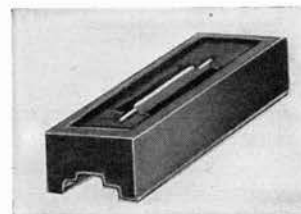

Cat. No.	Stock No.	Net Wt. 100 pairs
41-190	(890194)	1 lb.

## TYPE 52 INTERIOR JUNCTION BOX

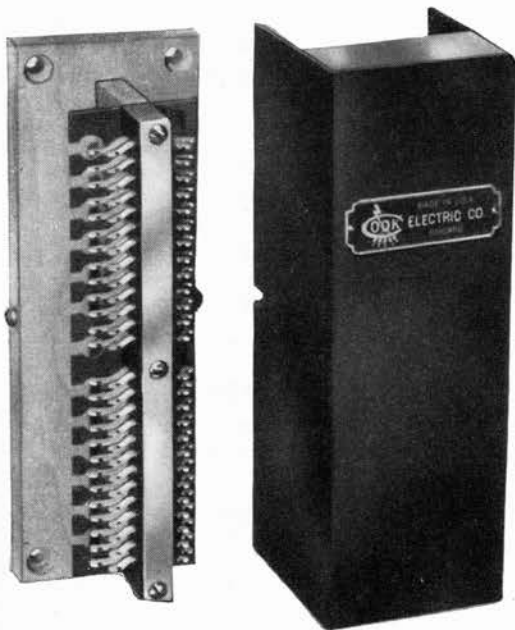

The Type 52 Interior Junction Box is designed to meet the need for a compact, convenient, low cost Junction Box for the termination and distribution of inside cables in PBX installations, small un-attended exchanges and floor cable distribution in factories, offices, stores, institutions, etc.

The Box consists of specially selected kiln dried maple base, drilled and countersunk for easy mounting on which a 26 pair 2 clip terminal block is mounted. The terminal block is made up of heavily tinned, formed metal clips set into hard rubber insulation. An insulating fanning strip is conveniently placed. A white designation strip is mounted above the terminals for identifying pairs. A strong enameled metal cover is screwed to the maple base.

Solder connections for permanently low resistance.

Furnished in 10, 20 and 26 pair sizes. Special sizes up to 52 pairs to order.

Catalog No.	Stock No.	No. Pairs	Dimensions	Net Wt. Lbs.
490-5210	(894878)	10	4 1/2 x 3 1/8 x 2 7/8	1 3/4
490-5220	(894879)	20	8 3/4 x 3 1/8 x 2 7/8	1 3/4
490-5226	(894880)	26	8 3/4 x 3 1/8 x 2 7/8	1 3/4

## TYPE WXB BUILDING TERMINAL

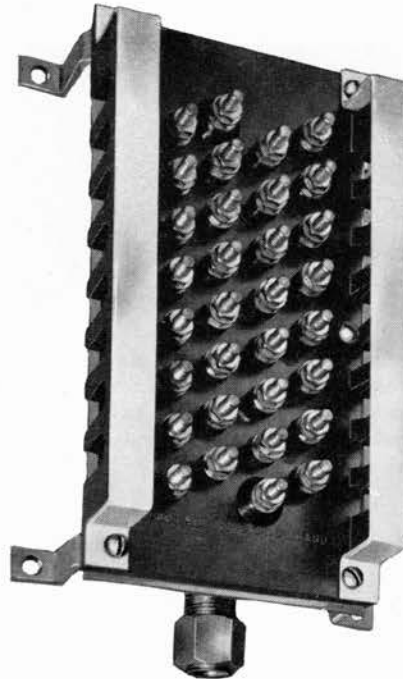

For terminating and distributing lead covered cable inside buildings.

The WXB Building Terminal provides many new conveniences for terminating and distributing lead covered cables inside of buildings. It is furnished for 6, 11, 16 or 26 pair cables in flush or surface type enameled steel boxes. The terminal unit consists of moisture-proof steel cable chamber and single piece moulded bakelite face plate and fanning strips. Non-corrosive studs are embedded in the bakelite, insuring strong low resistance connections. Cables enter the cable chamber through heavy compression fittings. Loom covered cables are also used satisfactorily with these terminals.

### WXB Surface Type

Cat. No.	Stock No.	Description	Lgth. In.	Wth. In.	Dth. In.	Net Wt.
452-8001	(890531)	11 pair less stub	10	8	3	16
452-8006	(890532)	11 pair with stub	10	8	3	14
452-8002	(890535)	16 pair less stub	10	8	3	6
452-8007	(890536)	16 pair with stub	10	8	3	14
452-8003	(890539)	26 pair less stub	15	8	4	9
452-8008	(890540)	26 pair with stub	15	8	4	20

## RELIABLE HEAT COIL FUSES



Fuse—Closed

The wire wound heat coils operate in accordance with standard specifications for protection of central office equipment. A very low resistance heating element is used because heat is not dissipated by metallic contact with mountings.

These sneak current fuses are designed to carry .35 ampere indefinitely, sustain short period overloads and open within five minutes when carrying .53 ampere (150% of rated current) at ambient temperature of 68° F.

Reliable No. 107 and No. 115-H heat coil fuses operate faster than standard 7-amp. line fuses when blown at 10.5 amp. or more.

After operating, the indicator plunger protrudes approximately an inch from the end of the fuse cartridge and can be readily seen from a distance. The fuses can normally be reset by pressing on the indicator plunger while a current of approximately one ampere is applied through the fuse.

Reset panels for these fuses are furnished with new distributing frames.

Cat. No.	Stock No.	Used In	Size—Inches Dia.	Shoulder To Shoulder
107	(894127)	303 Protectors	3/8	3 1/16
115H	(894769)	308 Protectors	5/16	3 1/16

STROMBERG-CARLSON

**FUSES FOR PROTECTORS AND CABLE TERMINALS**

Reliable fuses are of uniform quality and electrical characteristics. Sizes and types are available for all standard telephone protectors and cable terminals.

Early telephone fuses were rated at their blowing points. Later, power ratings came into wide use, permitting a fuse to carry rated current for an indefinite period and to blow within five minutes at 50% overload. Reliable standard fuses are in 1, 3 and 5 ampere telephone ratings, and 7 ampere power rating. Other power and telephone ratings are available on request. Starred catalog numbers are listed by the Underwriters' Laboratories in 7 ampere capacity.

**3/8" Ceramic and 7/16" Fibre with 13/64" Tips**



Cat. No.	Stock No.	Material	Shoulder To Shoulder	Standard Package	Ship. Wt. Lbs. per C
27L	(890218)	Ceramic	4 3/4"	50	6
*77	(890220)	Fibre	4 3/4"	50	5
*77	(890220)	Ceramic	4 3/4"	50	6
95L	(890221)	Ceramic	4"	50	5
31L	(890223)	Ceramic	3"	50	5

**7/16" Fibre with 3/8" Hex. Nuts**



Cat. No.	Stock No.	Material	Shoulder To Shoulder	Standard Package	Ship. Wt. Lbs. per C
*55	(890230)	Fibre	4 1/16"	50	7

**7/16" Fibre with 7/16" Hex. Nuts**



Cat. No.	Stock No.	Material	Shoulder To Shoulder	Standard Package	Ship. Wt. Lbs. per C
56	(890232)	Fibre	4 1/16"	50	8

**7/16" Fibre with Flat Tip**

Cat. No.	Stock No.	Material	Shoulder To Shoulder	Standard Package	Ship. Wt. Lbs. per C
*52	(890228)	Fibre	3 1/2"	50	4



**RELIABLE BLOW-RITE FUSE WIRE**

Blow-Rite Fuse Wire is a copper alloy wire specially made for telephone fuses. It has high tensile strength and can be soldered without fear of burning the wire. It will not corrode or crystallize.

Made in 1, 2, 3, 5 and 7-ampere capacities. Supplied on 300-foot spools. Stock No. (890237)

**RELIABLE MICA FUSES**

Made with superior grade of mica and heavy copper terminals. When ordering fuses, specify code number, amperage, open or enclosed type. Enclosed fuses supplied on standard sizes unless otherwise specified.



Western Union Type			Postal Type		
Cat. No.	Stock No.	Type	Size—Inches Length	Width	Standard Ship. Wt. Package Lbs per C
19	(890251)	WESTERN	2	3/8	50 1/2
8	(890252)	UNION	2 1/8	3/8	50 1/2
22	(890253)		2 1/2	1/2	50 1/2

Cat. No.	Stock No.	Type	Size—Inches Length	Width	Standard Ship. Wt. Package Lbs per C
137	(890254)		1 7/8 or 2	1/4	50 1/2
21	(890255)	POSTAL	2	3/8	50 1/2
11	(890256)		2 1/8	3/8	50 1/2
25	(890257)		2 1/2	1/2	50 1/2

**Enclosed Fuses**



Western Union Type			Postal Type		
Cat. No.	Stock No.	Type	Size	Standard Package	Uses Fuse No.
18	(894649)	WESTERN UNION	3 1/2 x 3/4 x 1 1/4	10	19
20	(894650)	POSTAL	3 1/2 x 3/4 x 1 1/4	10	21

**COOK HEAT COILS**

For Central Office Protectors



Type 4A  
Catalog No. 1162 Stock No. (894000)



Type 10  
Catalog No. 1103 Stock No. (894001)



Type 50 or 60  
Catalog No. 1125 Stock No. (894002)



Type 100 or 105  
Catalog No. 1232 Stock No. (894003)



Type 3800  
Catalog No. 1240 Stock No. (894004)

## FUSES Precision Rated

These fuses are designed for use in Cook Protectors and Terminals. To facilitate ordering, the illustrations show the actual size of each fuse. There are two methods of rating telephone and telegraph fuses. Power rated fuses will carry their rated capacity indefinitely without an undue rise in temperature, and will blow within five minutes on 150% of their rated capacity. Cook tele-

phone fuses recognize the importance of the telephone rating, which means that they will operate at their capacity, thus assuring critical protection. Cook Fuses are listed as approved by the Underwriters' Laboratories.

Fibre dowed power rated fuses are interchangeable with the corresponding types of telephone rated fuses.



### FUSES

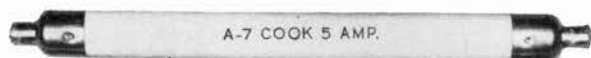

Cat. No.	Stock No.	Type	Used in	Wt. Lb. per 100
59-0700	(890238)	A-7 Wood	S-6, H-29-D, O-7	8
91-1200	(890250)	A-12 Lavite	H-51, O-12	7
146-0900	(890239)	A-9 Lavite	B-7, B-13, O-9	8
149-1600	(890244)	A-16 Wood	O-16	7
299-4400	(894128)	A-44 Wood	H-44	7
306-4500	(890249)	A-45 Lavite	H-36	7
307-4600	(890248)	A-46 Wood	H-36	7
424-5200	(890243)	A-52 Fibre	O-52	8
494-6200	(890245)	A-62 Fibre	O-62	8
499-6400	(890247)	A-64 Wood	O-64	7

### FUSE NEEDLE

Cat. No.	Stock No.	Description
59-16	(894044)	Steel needles for threading fuse wire.

### TYPE L9 WALL DISTRIBUTING FRAMES

The Type L9 Wall Distributing Frame is intended for economical distribution and protection of limited capacity cable and especially for installation in small exchanges.

The L-9 Wall Distributing Frame, made in 20, 40, 60, 80, and 100 pair sizes is designed to carry any Cook central office protec-

tor. The frame of the L-9 consists of two pieces of hard kiln dried maple, one drilled and arranged for, and equipped with, line terminals; the other drilled and milled for mounting the protectors; and two heavy mounting brackets of bar iron finished in durable paint.

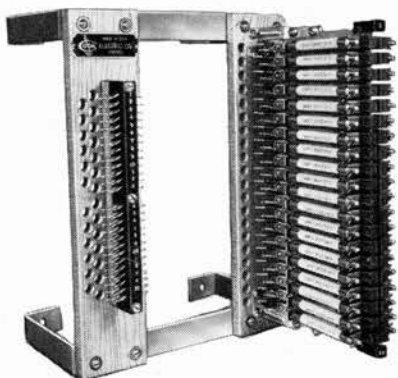

The frame is made up in the following sizes:

Cable side 26 pairs	Protector side 20 pairs.
Cable side 52 pairs	Protector side 40 pairs.
Cable side 78 pairs	Protector side 60 pairs.
Cable side 102 pairs	Protector side 80 pairs.
Cable side 130 pairs	Protector side 100 pairs.

Catalog No.	Stock No.	Description
361-1050	(894651)	20 pair
361-1052	(894652)	40 pair
361-1054	(894653)	60 pair
361-1056	(894654)	80 pair
361-1058	(894655)	100 pair

### S-C REPEATING COILS

#### In Weatherproof Housing

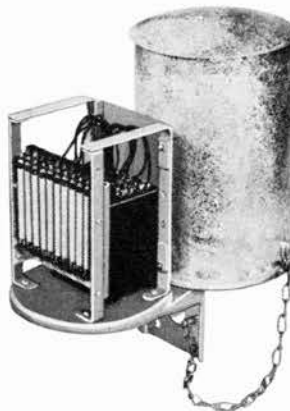

Forms phantom circuit either metallic or grounded.

Connects grounded section of line to metallic in electric light and power line induction clearance. Drains lines exposed to electric light and power line induction.

No. HT-610-A is equipped with one No. 15-B repeating coil and 3 pairs of protection. Stock No. (890574)

No. HT-610-B is equipped with two No. 15-B repeating coils and 5 pairs of protection. Stock No. (890575)

**RELIABLE TYPE 303 AND 308  
MAIN DISTRIBUTING FRAMES**

Type 303 and 308 Main Distributing Frames offer two arrangements in terminating outside exchange cables and switchboard cables. The outside cable can be terminated on either the line terminal or protector side. Cross connectors are provided by jumper wires. The frame is strong and rigid. Jumper rings are provided on the main uprights. Protector fanning strip and line terminal fanning strips are provided, for a neat and convenient cable and jumper layout.

Each vertical section has a capacity of 100 or more pairs of protectors mounted in banks of 20 pairs each, and 130 or more pairs of 112F line terminal blocks in 26 pair blocks. Terminal blocks may be attached in either horizontal or vertical rows as ordered.

Line terminals and protectors are numbered as specified.

In addition to the standard frames shown, Reliable main distributing frames are made to meet specific requirements, and estimates will be furnished on request. Specify type of frame, protectors, terminal blocks, fanning strips, and iron work.

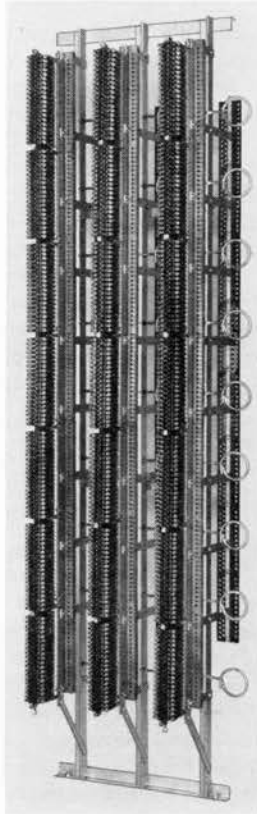

Cat. No.	Stock No.	Fuse	Other Units
303F (894881)		106	P495 Dischg. Blk., P663 Carbons
303H (894882)		107 Heat Coil	P495 Dischg. Blk., P663 Carbons
308F (894883)		114	4393 Carbon and Dielectric Units
308H (894884)		115 Heat Coil	4393 Carbon and Dielectric Units

**COOK TYPE L  
MAIN DISTRIBUTING FRAMES**

Type L Main Distributing Frames provide the advantage of two methods of terminating the outside cable on the frame. The cable entering the central office can be terminated on line terminals and the switchboard cable on protectors or, the outside cable can be terminated on protectors and the switchboard cable on line terminals. Flexible jumper wires connect the line terminals and protectors. Any outside pair, therefore, can be connected to any switchboard pair. Type L Main Distributing frames are furnished either welded or knocked down and bolted. These frames are also exclusively equipped with a special alarm circuit for signalling heat coil operation. Protectors afford a convenient means for testing both outside lines and switchboard circuits and cutting them in and out of service. Cut shows several types of Protectors.

Three types of protector groups are available: (1) lightning arresters and heat coils; (2) lightning arresters and fuses; (3) fuses, arresters and heat coils.

**COOK MAIN DISTRIBUTING FRAME**

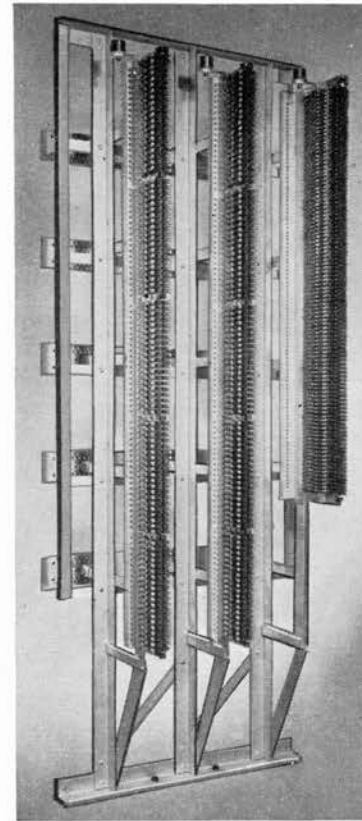

Type L Frames are constructed of steel in sectional form, 100 or more pairs in height. Additions may be added to right or left. Frames are attractively finished in durable paint unless otherwise ordered. Stock No. (894039)

**CENTRAL OFFICE PROTECTORS  
Type No. 100**

For cable termination and protection of central office equipment and personnel from high potentials and sneak currents. Pairs are mounted on 1/2" centers.

The No. 100 Central Office Protector opens the switchboard circuit and grounds the outside line; it operates an automatic alarm circuit; it provides for temporary disconnect; it is equipped with the Cook patented self-soldering, relatching heat coils of low resistance which can be reset without changing coil; its line connections are on one side of protectors and switchboard connections are on the other side; testing may be done without removing the heat coil.

Heavy carbon and heat coil holding springs in the No. 100 Protector insure a positive permanent pressure between the precision ground discharger carbons and the ground plate. All current carrying parts are thoroughly insulated by hard rubber and bakelite.

In operation the No. 100 Protector opens the switchboard circuit, grounds the outside line and operates an alarm signal.

Cat. No.	Stock No.	Description of Section	Lgth. In.	Width In.	Depth In.	Net Wt. Lb.	100 Prs.
360-1210	(894035)	10 pair	5 1/2	2	3 1/2	17	
360-1220	(894036)	20 pair	10 1/2	2	3 1/2	17	

## CENTRAL OFFICE PROTECTOR

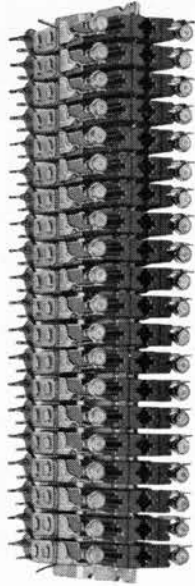

A Typical Cook Central Office Protection Unit, such as are used with Protectors on this and preceding page.

### Type No. 3800

Pairs are mounted on  $\frac{3}{8}$ " centers.

The No. 3800 Central Office Protector offers the same combination of protection features as the No. 100. As in the No. 100, the No. 3800 protector is reset after operation by simply relatching the operating spring over the heat coil. There are no coils to change, reverse or resolder.

Cat. No.	Stock No.	Description of Section	Lgth. In.	Width In.	Depth In.	Net Wt. Lb. 100 Prs.
380-1320	(894037)	20 pair	8 $\frac{5}{8}$	3	4 $\frac{3}{4}$	23

### Type No. 105

Provides fuse protection in addition to lightning arresters and heat coils for the protection of central office personnel and equipment. Pairs are on  $\frac{1}{2}$ " centers.

This protector is especially recommended for the protection of toll line and carrier circuits.

Extraneous currents of low intensity operate the No. 105 Central Office Protector heat coil, ground the outside line, and operate the alarm signals. High potentials go to ground across the air gap of the lightning arresters. A current of 3 amperes or more will operate the fuse.

Mounting plates are metal and may be mounted on a standard frame, carrying protectors on  $\frac{1}{2}$ " centers. The circuit from the heat coil spring to the switchboard terminal is carried between the grounded mounting plates and is well shielded.

Cat. No.	Stock No.	Description of Section	Lgth. In.	Width In.	Depth In.	Net Wt. Lb. 100 Prs.
392-1510	(894758)	10 pair	5 $\frac{1}{2}$	3	7	41
392-1520	(894759)	20 pair	10 $\frac{1}{2}$	3	7	41

### Type H-36

Provides fuses and lightning arresters.

For small town rural exchanges where sneak current hazard does not exist the H-36 Protector offers an ideal protector unit. This time-tested protector, built on heavy zinc metal plates, gives both fuse and lightning arrester protection.

The unit is fire-proof. The H-36 has had thirty years of successful field use in those areas in which lightning conditions have been unusually severe.

The H-36 Central Office Protector is built in 10 and 20 pair sections in metal plates. Pairs are on  $\frac{1}{2}$ " centers. Fuse clips and insulation the same as in the No. 105.

Type A-45 fuses which blow at 1 ampere are furnished as standard. A-46 wood fuses will be furnished when specified.

Cat. No.	Stock No.	Description of Section	Lgth. In.	Width In.	Depth In.	Net Wt. Lb. 100 Prs.
296-3610	(894042)	10 pair	5 $\frac{1}{2}$	1 $\frac{1}{2}$	5 $\frac{1}{2}$	21
296-3620	(894043)	20 pair	10 $\frac{1}{2}$	1 $\frac{1}{2}$	5 $\frac{1}{2}$	21

## TRUMBULL SWITCHES



There are still many application for open knife switches. Trumbull switches meet the requirements of high quality and suitability. The switches shown are front connected, no fuse, single and double throw, with porcelain base and plain (bright) finish. 30 Amperes.



Switches 707, 708 have 1 pole, Weight  $\frac{1}{4}$  pound, each.

Switches 709 and 710 have 2 poles. Weight  $\frac{1}{2}$  pounds, each.



Cat. No.	Stock No.	Throw	Dim. In.
707	(890258)	Single	2 $\frac{7}{16}$ x1 $\frac{1}{4}$
708	(890259)	Double	3 $\frac{5}{8}$ x1 $\frac{5}{16}$
709	(890260)	Single	2 $\frac{7}{16}$ x2
710	(890261)	Double	3 $\frac{5}{8}$ x2

## PARAGON BATTERY BOXES



Made of heavy pressed steel and finished in bright black wrinkle. Lined throughout with insulating fibre.

Cover fits tightly and is attached to the box with nickel-plated chain. Holes are provided in the top and bottom for bringing in wires. Box is neat and durable and will thoroughly protect the batteries. Each box is individually packed in a carton.

Cat. No.	Stock No.	Capacity Standard No. 6 Dry Cells	Wt. Lb.
2	(890305)	2	1 $\frac{1}{2}$
3	(890306)	3	2 $\frac{1}{2}$

## STROMBERG-CARLSON



**NO. 6 COLUMBIA GRAY LABEL  
DRY CELLS**

Especially designed for telephone service. Noted for its long life on light drain service; exceptionally high in recuperative power. Round jacket; dimensions 2 5/8" dia. x 6 5/8" high. 1 1/2 Volts. Standard package 25 cells; approximate weight 58 pounds.

Stock No. (890302)

**NO. 487 MINIMAX  
B BATTERY**



This Eveready B Battery will outlast the large bulky round-cell types. Dimensions 5 1/8" x 2 1/16" x 7 1/4". 45 Volts. Standard package 10 cells; approximate weight 44 pounds.

Stock No. (894803)

**NO. 950 EVEREADY CELL**

This battery has been recently improved for longer life. Light in weight, being designed expressly for portable equipment. Dimensions 1 21/64" dia. x 2 27/64" high. 1 1/2 Volts. Standard package 48 cells; approximate weight 9 1/4 pounds



Stock No. (894073)

**386C Specialty Battery Company Unit Type  
Telephone Battery**

This battery is manufactured by the Specialty Battery Company, a subsidiary of the Ray-O-Vac Company. It is manufactured under the same quality-controlled production which has made Ray-O-Vac products famous for their high quality. The 386C is a 3-volt battery, equivalent of two No. 6 cells, housed in a single compact carton. They are convenient and economical. These batteries are supplied in mailing cartons ready to be sent to the subscriber who then makes the change himself. The 386C is a 3-volt battery measuring 3 7/8 x 2 5/8 x 5 3/8. It is packed in a standard package of 10 weighing 27 pounds.



Stock No. (890308)

**4945C Specialty Battery Company  
Transmitter Battery**

This battery is also manufactured by Specialty Battery Company, a subsidiary of Ray-O-Vac, under Ray-O-Vac's quality-controlled production. It is designed for use at operators' positions on telephone switchboards. It is composed of a number of small highly efficient cells connected in series parallel, to furnish 4 1/2 volts. It is provided with long service capacity and a uniform voltage characteristic. The 4945C is a 4 1/2-volt battery measuring 11 7/8 x 4 1/8 x 7. It is packed in a standard package quantity of two, weighing 32 pounds.



Stock No. (890307)

**489C Specialty Battery Company Unit Type  
Telephone Battery**

The 489C is a unit type plug in battery. It is a 4 1/2-volt battery, the equivalent of three No. 6 cells. It is housed in a single compact carton and is convenient and economical. These batteries are supplied in mailing cartons ready to be sent to the subscriber who then makes the change himself. The 489C is a 4 1/2-volt battery measuring 3 7/8 x 3 7/8 x 5 3/8 and packed in a standard package quantity of 10, weighing 43 pounds.



Stock No. (890309)

**DRY CELLS**

**No. 6 Ray-O-Vac Telephone Battery**

For a long life and low saving cost always use Ray-O-Vac No. 6 Telephone batteries. Quality controlled production insures maximum performance. Long life in performance cuts down replacements and keeps operating costs low. No. 6 Telephone 1 1/2 volts, round 6-inch battery, packed in standard packages of 25, weighing 58 pounds.



Stock No. (890304)

## EVEREADY AIR CELLS



T-1300



T-2600



T-2300



T-1600

Air depolarized, constant voltage primary batteries. Especially designed for telephone, railroad and industrial use where a uniform current supply is necessary at all times at a low ampere-hour cost.

Eveready Air Cell batteries are made in single cell units or in batteries consisting of two cells in series. The average voltage per cell is 1.25 volts under discharges usual in telephone transmission.

Batteries are shipped dry and are actuated by merely filling with the proper quantity of ordinary drinking water.

Air Cell No. T-1600 and T-2600 capacity 600 amp. hr.; Height 11 3/16 inches.

Air Cell No. T-1300 and T-2300 capacity 300 amp. hr.; Height 8 5/8 inches.

Type	Stock No.	Cells	Volts	Dimensions in In. Length Width	Wt. Lb. Dry
T-1600	(894203)	1	1.25	5 <sup>23</sup> / <sub>64</sub> x6 <sup>19</sup> / <sub>32</sub>	11
T-2600	(894204)	2	2.5	9 <sup>29</sup> / <sub>32</sub> x6 <sup>19</sup> / <sub>32</sub>	21
T-1300	(894804)	1	1.25	5 <sup>5</sup> / <sub>16</sub> x4 <sup>11</sup> / <sub>32</sub>	6
T-2300	(894805)	2	2.5	8 <sup>1</sup> / <sub>4</sub> x5 <sup>5</sup> / <sub>16</sub>	11

### GENERAL INDEX

A complete alphabetical index with cross references for all the products shown in this section or any of the other sections will be found in the center of this catalog.

**STROMBERG-CARLSON**

# Wire



**Habirshaw neoprene and braid type drop wire; general purpose Habidure interior and jumper wire; high tensile line wire; galvanized tie wire; guy and messenger strand.**

CONTENTS  
SECTION R

**WIRE**

---

	Page
<b>Insulated Telephone Wire</b>	
Mica Flake Bronze Wire .....	3r
Bridle Wire .....	4r
Interior Wire .....	4r
Neoprene Sheathed Bronze Wire .....	5r
Habirdure General Purpose Wire .....	6r
Ordering Information, Habirshaw Wire .....	6r
Rubber Insulated-Lead Covered Wire .....	7r

---

**Bare Wire and Strand**

Steel Telephone Line Wire .....	7r
Bare Copper Line Wire .....	7r
Galvanized Construction Wire .....	7r
Galvanized Telephone Wire .....	8r
Copperweld Line Wire .....	8r
Galvanized Guy and Messenger Strand .....	9r
Copperweld Strand .....	9r

---

## LONG LIFE INSULATED TELEPHONE WIRES

Manufactured by  
Habirshaw Cable and Wire Division of  
PHELPS DODGE COPPER PRODUCTS CORPORATION  
For Sale Exclusively Through  
STROMBERG—CARLSON COMPANY

## Specifications for No. 17 A.W.G. (B &amp; S) Bronze Outside Distributing Wires

## Mica Flake Finish—100 Megohm Grade

**Twisted Pair**

The material consists of two separately insulated tinned bronze or alloy coated conductors, each covered with a weatherproof braid and twisted together into what is termed a twisted pair.

**General**

The purpose of this specification is to cover a type of wire to be used in "drops" extending a telephone circuit from open wire leads or distributing cable terminals to the subscriber.

**Conductor**

The conductor shall be of tinned or alloy-coated copper alloy wire, free from scales, flaws, splints or other imperfections. **DIMENSIONS**—The size shall be No. 17 A.W.G. (B. & S.) (.045") and shall have after coating, a diameter not less than .044" or greater than .047".

**COATING**—The coating shall be complete and meet the requirements for tin coating of copper wire as specified in the A.S.T.M.—B33 or alloy coating in accordance with B189.

**TENSILE STRENGTH**—The tensile strength of the conductor shall not be less than one hundred and seventy (170) pounds.

**ELONGATION**—The elongation, as observed on a 10" sample, shall be not less than 1.2%.

**RESISTANCE**—The resistance per one thousand feet of conductor shall not exceed seventeen (17) ohms at sixty (60) degrees Fahrenheit.

**Insulation**

Each tinned conductor shall be covered with a rubber insulating compound of such composition that it will meet the requirements hereinafter specified.

**GENERAL**—The insulation must be seamless and the conductor well centered. The compound must be homogeneous and not act injuriously upon the conductor.

**DIMENSIONS**—The diameter over the rubber insulation shall not be less than one hundred and nine thousandths (.109") of an inch and thickness of wall at thinnest point shall not be less than twenty-nine thousandths (.029") of an inch.

**ADHESION**—The compound shall adhere to the conductor so that when the insulated wire with the braid removed, is held firmly with the fingers of one hand and a twisting force is applied to the insulation with the fingers of the other hand, at a point two (2) inches away, there shall be a noticeably firm adhesion between insulating compound and conductor.

**FLEXIBILITY**—The compound shall be flexible so that the insulated conductor with the braid removed shall be capable of being wrapped three (3) times about itself, left for at least sixteen (16) hours, but not more than twenty-four (24) hours, and then unwrapped and wrapped again about itself in the reverse direction, without insulation showing signs of rupture.

**Parallel**

The material consists of two separately insulated tinned bronze or alloy coated conductors laid parallel and covered with a single weatherproof cotton braid.

**NEW WIRE TEST**—In the compression test on new unaged wire, the separation of the steel plates at the time the crushing load is reached, shall not be more than .067 of an inch. The load to produce crushing shall be not less than eight hundred (800) lbs.

When the insulation of the two sides of the wire crushes simultaneously the crushing shall be so abrupt that the addition of sixty (60) pounds to the crushing load shall effect a reduction in the separation of the plates not less than .007 of an inch.

When the insulation walls do not crush simultaneously, the two abrupt decreases in the separation of the steel plates shall be added. The two load increments required for effecting this thickness reduction shall also be added. The crushing of the two walls shall occur with such abruptness that a total increment in load of sixty (60) pounds at the two crushing will effect a total reduction in thickness of .007 of an inch.

**AGING**—The compound must be designed so as to meet the following requirements to ensure its aging qualities:

A piece of the insulated conductor from which the braid has been removed without injury to the insulation will be placed longitudinally between the parallel faces of two steel plates, the face of each plate being two inches by one inch (2" x 1"). A load resulting from decreasing the separation of the plates at an approximately uniform rate shall be applied to the insulating conductor held between the plates until the insulation crushes. The speed of the compression testing machine shall be such that when any sample is between the plates, the rate of approach of the plates shall be approximately one and one-half (1½") inches per minute.

The crushing load shall be taken as that load which produces the initial abrupt reduction in the separation of the steel plates without a proportionate increase in the load.

**ACCELERATED AGING**—A piece of the insulated conductor from which the braid has been removed without injury to the insulation, shall be subjected for a minimum period of forty-eight (48) hours to an atmosphere of oxygen at a pressure of not less than two hundred and ninety pounds (290) per square inch, nor more than three hundred and ten (310) pounds, and at a temperature of not less than sixty-nine (69) degrees Centigrade, nor more than seventy-one (71) degrees Centigrade.

**AGED WIRE TEST**—Any length of insulated conductor which has been subjected to an accelerated aging hereintofore described, shall withstand, without crushing, a load of not less than six hundred (600) pounds, provided that in no case shall this load be less than three-quarters (¾) of the value obtained on the same sample prior to accelerated aging.

STROMBERG-CARLSON

Specification for No. 17 A.W.G. (B & S) Bronze Outside Distributing Wires (Cont.)

**Braiding**

After vulcanizing, each insulated conductor shall be covered with a close, smooth braid of soft unbleached cotton, which, with the exception of the raised tracer hereinafter described, shall consist of number thirty (30), two (2) ply, three (3) end cotton. The braid shall be applied with a sixteen (16) carrier braider at an angle of lay approximately forty-five (45) degrees and not less than 16.2 picks per inch.

In order that the wires in the twisted pair may be distinguished from each other, the braid of one wire shall include a raised tracer of number eight (8), four (4) ply, one (1) end soft unbleached cotton, which must be readily perceptible to the touch throughout the finished wire.

For manufacturer's identity, the regular N.E.C. marker will be used, i.e., one blue thread woven in the braid of one conductor or one blue thread parallel to the conductor between the insulation and the braid of the conductor.

**Saturant**

The braid shall be thoroughly saturated with an asphalt saturant of high penetration value with moisture resistant qualities.

**Finish**

Over the saturated braid shall be applied a continuous and complete coating of finishing compound of high melting point. The weatherproofing materials shall not act injuriously upon the insulation or braid and shall withstand the following tests:

**MELT TEST**—Short pieces of the wire shall be placed on a piece of clean white paper in an oven which has been heated to one hundred and twenty-five (125) degrees Fahrenheit, which temperature shall be maintained for half an hour. The finishing compound shall not become sufficiently fluid to be transferred to the paper on which the samples were placed as indicated by the presence of an amount of compound sufficient to form a ridge perceptible to the touch.

**FREEZE TEST**—The saturating and finishing compound shall not crack. In this test, the wire shall be temperature of ten (10) degrees below zero Fahrenheit.

Examination for cracks to be made without bending the sample.

**WRAP TEST**—When a sample of the finished wire at a temperature of thirty-two (32) degrees Fahrenheit is wrapped in a close spiral about a mandrel one-half (1/2") of an inch in diameter, the braid shall not crack. In this test, the wire shall be wrapped around the mandrel at a rate of approximately twenty (20) turns per minute.

**DIAMETER**—The outside diameter of the completed wire in the twisted pair shall not exceed one hundred and ninety thousandths (.190) of an inch.

**Lay of Wires**

The two insulated and braided conductors constituting the pairs (one plain, one tracer), shall be twisted together with a right-hand lay.

A right-hand lay is defined as a clockwise twist away from the observer.

The length of twist shall not be more than six (6") inches. The length of complete twist in any piece of wire shall not differ from each other by more than three-quarters (3/4) of an inch.

**Electrical Requirements**

**VOLTAGE TEST**—After 12 hours immersion in water, the completed wire, while still immersed, must withstand the application of one thousand (1000) volts A.C. for a period of five (5) seconds without rupture.

**INSULATION RESISTANCE TEST**—After the voltage application and while still immersed, the completed wire shall have an insulation resistance not less than shown in the following table, the temperatures being those of the water in the tank:

Temperature Degrees Fahrenheit	Insulation Resistance Megohms per Mile
38-41	200
42-46	170
47-50	145
51-55	120
56-64 (normal)	100
65-69	85
70-74	70
75-79	60
80 and over	50

The insulation resistance test shall be made with an electromotive force of not less than one hundred (100) volts. The insulation resistance shall be computed from the galvanometer deflection obtained after an electrification of one (1) minute with the negative pole of the source of potential connected to the wire.

**Patching**

Faults in the insulating covering developed during the process of manufacture may be repaired. All repairs (patches) must be made in a neat, workmanlike manner and must withstand the electrical tests hereintofore described.

**Coils**

The finished pairs shall be put into coils of one thousand (1000) feet. The coil shall have an eye diameter of approximately sixteen (16") inches.

**Packing**

The coiled wire shall be securely tied with strong tape or twine in at least four (4) places and shall be wrapped with strong paper, tightly applied with an edge fold so as to ensure complete protection during handling.

Each coil will have affixed thereto two strong tags, one outside and one inside the wrapping, showing length, description and manufacture.

**Bridle Wire**

A rubber covered, saturated weatherproof braided soft drawn copper wire used in ring wiring and in bridling open wire lines.

Conductor is coated soft annealed copper in accordance with A.S.A. Specifications. Rubber insulation and braiding of same high quality as covered by drop wire specifications. Raised tracer furnished where necessary. Furnished with one, two, or three conductors in gages from 14 AWG to No. 22 AWG.

**Interior Wire**

This is a high grade rubber covered braided wire for use inside buildings for extending telephone circuits from outside lines to telephones. Furnished in one, two, or three conductors and in both No. 19 AWG and No. 22 AWG.

Conductor is coated soft copper covered with a hard glazed cotton braid. No. 19 gage is finished with an olive green braid, No. 22 gage with brown braid.

### Specification for No. 17 Bronze Twisted Pair Neoprene Sheathed Outside Distributing Wire



Stock No. Twisted Pair (894607)

1. **SCOPE**—This specification covers a telephone "drop" wire consisting of two separately insulated and neoprene sheathed bronze conductors twisted together to form a pair.

2. **CONDUCTOR**—The conductor shall be No. 17 A.W.G. bronze uniformly coated with tin or a lead tin alloy and shall conform to the following dimensions and characteristics.

Dimensions: The size shall be No. 17 A.W.G. and after coating shall have a nominal diameter of .045" and a minimum diameter of not less than .044".

Coating: If tin is used it shall conform to the requirements of ASTM B-33 and if alloy coated it shall conform to the requirements of ASTM Spec. B-189.

Tensile Strength: The tensile strength of the conductor shall be not less than 170 lbs.

Resistance: The resistance of the conductor shall not exceed 92 ohms per mile at 60° F.

3. **INSULATION**—Each coated conductor shall be covered with an insulating compound to meet the requirements hereinafter specified.

Dimensions: The diameter over the insulation shall be not less than .109" and the wall at the thinnest point shall be not less than .025".

Flexibility: The compound shall be flexible so that the insulated conductor shall be capable of being wrapped three times about itself, left for sixteen hours but not more than twenty-four hours and then unwrapped and wrapped again about itself in the reverse direction without the insulation showing signs of rupture.

4. **SHEATH**—Each insulated conductor shall be covered with an abrasion and weather resisting sheath of a neoprene compound such that the finished wire shall meet the requirements hereinafter specified.

Dimensions: The thickness of the sheath shall be nominally .020" thick. The maximum diameter of the insulated and sheathed conductor shall not be greater than .170".

5. **AGING**—A sample of completed wire, after aging shall be tested in a standard "Scott" compression testing machine having compression plates 2" x 1".

After aging for a period of 48 hours in the oxygen pressure test at 300 lbs. pressure at 70° C. the crushing load shall not be less than 800 lbs.

6. **LAY OF WIRES**—The two insulated and sheathed conductors, one plain and one with a ridge tracer shall be twisted together with a right-hand lay. The length of twist shall not be more than 5".

7. **ELECTRICAL TESTS**—

Voltage test: After 12 hours immersion in water, the completed wire must withstand the application of 1000 volts A.C. for a period of 5 seconds without rupture.

Insulation resistance: After the voltage test and while still immersed the completed wire shall have an insulation resistance at 60° F. (15.5C) of not less than 500 megohms per 1000 feet.

The insulation resistance test shall be made with an electromotive force of not less than 100 volts and the insulation

resistance computed from the galvanometer deflection after an electrification of one minute with the negative pole of the source of potential connected to the wire.

8. **PATCHING**—Faults in the insulation and sheath developed during manufacture may be repaired. All repairs are to be made in a neat and workmanlike manner and must withstand the electrical tests hereinbefore described.

9. **COILS**—The finished pairs shall be put up in coils of not less than 200 feet nor more than 1500 feet in length, the desired average being approximately 1000 feet. The diameter of the eye of the coil shall be approximately 15".

10. **PACKING**—The coiled wire shall be tied in four places and wrapped with strong paper, tightly applied with an edge fold.

Each coil shall have affixed thereto two strong tags, one inside and one outside of the wrapping, showing length, description and name of manufacturer.

### Specification for No. 17 Bronze Parallel Neoprene Sheathed Outside Distributing Wire



Stock No. Parallel (894608)

1. **SCOPE**—This specification covers a telephone "drop" wire consisting of two insulated bronze conductors, the two conductors laid parallel and covered with an open weave binder braid and a neoprene sheath. The completed assembly being suitable for either aerial or underground service.

2. **CONDUCTOR**—The conductor shall be No. 17 A.W.G. Bronze uniformly coated with a tin or lead tin alloy and shall conform to the following dimension and characteristics.

Dimensions: The size shall be No. 17 A.W.G. and after coating shall have a nominal diameter of .045" and a minimum diameter of not less than .044".

Coating: If tin is used it shall conform to the requirements of ASTM spec. B-33 and if alloy coated it shall conform to the requirements of ASTM B-189.

Tensile Strength: The tensile strength of the conductor shall not be less than 170 lbs.

Resistance: The resistance per one mile of conductor at 20° C (68° F) shall not exceed 92 ohms.

3. **INSULATION**—Each coated conductor shall be covered with an insulating compound of such composition that it will meet the following requirements.

Dimensions: The nominal diameter of the insulation shall be .110" and shall be not less than .105". The thickness of the wall at the thinnest point shall be not less than .020".

Flexibility: The compound shall be flexible so that the insulated conductors with the braid removed, shall be capable of being wrapped three times about itself, left for sixteen hours but not more than twenty-four hours and then unwrapped and wrapped again about itself in the reverse direction, without the insulation showing signs of rupture.

Accelerated Aging: Samples of single insulated conductor from which the braid and jacket have been removed shall be subjected to an atmosphere of oxygen at a pressure of not less than 290 psi. or more than 310 psi. at a temperature of 70° C ± 1° C for a period of 48 hours.

Any sample of insulated conductor which has been subjected to the above aging test shall withstand a crushing load of not less than 800 lbs. when tested in a standard Scott Compression Tester at a temperature of 75° F.

## Specification for Habirdure Insulated General Purpose Telephone Wire

1. **SCOPE**—This specification covers one, two and three conductor Habirdure insulated telephone wire in sizes 16, 18, 19, 20 and 22 AWG.

This wire is flameproof and suitable for use as inside wire, duct wire or distributing frame wire. It may be used exposed or in raceways and is suitable for either wet or dry locations.

2. **CONDUCTORS**—Each conductor shall be of soft annealed uncoated copper in conforming to ASTM spec. B-33.

Dimensions: Conductor dimensions shall conform to Table I below.

3. **INSULATION**—Each conductor shall be covered with Habirdure insulation, a thermoplastic compound of the polyvinyl chloride type so formulated as to meet the requirements hereinafter specified.

Dimensions: The nominal diameter over the insulation shall conform to Table I below.

Colors: The Insulation can be furnished in black, olive green, brown or cream. For use as distributing frame wire it



can be furnished in the usual red, black and white combinations if desired.

Polarity identification, where all conductors are of the same color, is obtained by means of ridge tracers. Single conductor wire is plain, Twisted pair wire has one conductor plain and one with a ridged tracer. Three conductor wire has one conductor plain, one with a single ridge and one with a double ridge.

4. **ASSEMBLY**—Two and three conductor wire shall consist of two or three insulated conductors twisted together with a right hand lay. The length of twist shall not be greater than 2½ inches on two conductor wire and 3 inches on 3/C wire.

5. **COILS**—The finished wire shall be put up in coils of not less than 100 nor more than 1500 ft. The average length being approximately 1000 ft.

6. **SHIPPING**—The coils shall be shipped in fiber board cartons or other approved containers.



TABLE I

Size AWG	Number Conductors	Stock No.	Nom. Cond. Dia.	Min. Cond. Dia.	Sg. Resist. Ohms/1000	Cond. Dia. over Insulation
19	Single	(894076)	.036	.035	8.54	.070
19	Twisted Pair	(894077)	.036	.035	8.54	.070
19	Triplex	(894078)	.036	.035	8.54	.070
22	Single	(894079)	.025	.024	12.0	.057
22	Twisted Pair	(894080)	.025	.024	12.0	.057
22	Triplex	(894081)	.025	.024	12.0	.057

Physical properties: The physical characteristics of the insulating compound shall conform to the requirements of Table II shown at the right.

TABLE II

Tensile strength, min. psi. ....	1500
Elongation at rupture, min. percent .....	100
Depreciation in tensile strength after 120 hrs. in air oven at 100° C max. percent .....	15
Depreciation in elongation after 120 hrs. in air oven at 100° C max. percent .....	40

## Summary of Habirshaw Rubber Insulated Telephone Wire

### Telephone Drop Wire in 1000-Ft. Coils

Diameter over Rubber, .109 inch; Conductors are bronze.

A.W.G.	Stock No.	No. of Conductors	Wt. Lb. per 1000 Ft.
17	(892985)	Single	16
17	(892986)	Twisted Pair	33
17	(892987)	Parallel	32

### Interior Wire in 500-Foot Coils

Diameter over Rubber, .055 inch; Color of Braid, Brown.

A.W.G.	Stock No.	No. of Conductors	Wt. Lb. per 1000 Ft.
22	(893004)	Single	5
22	(893005)	Twisted Pair	10
22	(893006)	Triplex	15

### Bridle Wire in 500-Ft. Coils

Diameter over Rubber, .109 inch; Conductors are bronze.

A.W.G.	Stock No.	Dia. over Rubber	No. of Conductors	Wt. Lb. per 1000 Ft.
22	(892988)	.063	2	14
22	(892989)	.063	3	21
20	(892990)	.085	2	20
19	(892991)	.093	1	11
19	(892992)	.093	2	22
19	(892993)	.093	3	33
18	(892994)	.109	1	15
18	(892995)	.109	2	31
18	(892996)	.109	3	46
16	(892997)	.125	1	21
16	(892998)	.125	2	42
16	(892999)	.125	3	63
14	(893000)	.156	1	30
14	(893001)	.156	2	60

Diameter over Rubber, .093 inch; Color of Braid, Olive Green.

A.W.G.	Stock No.	No. of Conductors	Wt. Lb. per 1000 Ft.
19	(893007)	Single	10
19	(893008)	Twisted Pair	21
19	(893009)	Triplex	31

### Ground Wire

Ground wire is furnished in single conductor only and is of No. 14 A.W.G. copper, rubber covered and finished with a wax braid. Furnished in either white or black color.

### In 500-Foot Coils

Diameter over Rubber, .126 inch.

A.W.G.	Stock No.	No. of Conductors	Color	Wt. Lb. per 1000 Ft.
14	(893039)	Single	White	36
14	(893040)	Single	Black	36

**RUBBER INSULATED-LEAD COVERED WIRE**



Used for telephone wiring buried in the earth or running through mines, subway, etc. Lead covering protects wire from mechanical injury and excludes moisture.

Cat. No.	Stock No.	No. of Conduct.	B & S Gauge	Rubber Thickness Wall In.	Lead In.	Wt. Lb. per 1000 ft.
2363	(893099)	1	16	2/64	2/64	155
2364	(893100)	1	14	3/64	2/64	183
2365	(893101)	2	16	2/64	2/64	278
2366	(893102)	2	14	3/64	2/64	289

**CRAPO HIGH-TENSILE LOW-RESISTANCE TELEPHONE LINE WIRE**

**HTL-85 Line Wire**



The high-strength double galvanized line wire with superior telephonic characteristics. Makes possible longer spans on new construction; provides stronger spans, with increased factor of safety, on existing lines. Provides for spans of 225 feet in heavy loading districts, 325 feet in medium loading districts, 375 feet in light loading districts. Affords

better transmission at voice-frequencies with currents of voice-frequency magnitude. Crapo extra galvanized.

Galvanized steel compression-type sleeves are recommended for splicing HTL-85 wire. Furnished in continuous lengths without splices or joints as follows:

Length of Coil, 1/2 mile.

Size B.W.G.	Stock No.	Diam. In.	Approx. Wt. Lb. per Mile	Min. Break. Strength Pounds	Max. Resist. Ohm per Mile
9	(893125)	0.148	314	1462	18.47
10	(893126)	0.134	258	1199	22.48
12	(893127)	0.109	170	793	34.12
14	(893128)	0.083	99	460	58.59

**LINE WIRE—BARE COPPER**

B & S Gauge	Stock No.	Diam. In.	Wt. Lbs. per Mile	Wt. Lbs. per Coil
6	(893103)	.162	420	220
8	(893104)	.128	264	220
9	(893105)	.114	209	220
10	(893106)	.102	166	220
12	(893107)	.081	104	125
14	(893108)	.064	66	125

**CRAPO GALVANIZED CONSTRUCTION WIRE**

For miscellaneous construction purposes, such as light guys, wrapping stubbed poles, lashing brackets to poles, etc.

Galvanized by Crapo process.

In sizes No. 6 B.W.G. to No. 14 B. W. G.

Size B.W.G.	Stock No.	Diam. In.	Approximate Wt. Lb. Per Coil	Length Ft. Per Coil	Break. Strength Pounds
6	(893120)	.203	150	1320	1618
8	(893121)	.165	100	1320	1069
10	(893122)	.134	100	2050	705
12	(893123)	.109	100	3150	467
14	(893124)	.083	50	2700	271

**HTL-135 Steel Line Wire**

Spans of 350 feet in heavy loading districts, 450 feet in medium loading districts and 500 feet in light loading districts are practicable with HTL-135 line wire. This extra-high strength line wire has a minimum tensile strength approximately two and one-half times that of standard B.B. wire.

HTL-135 high-strength line wire is galvanized by the time-tested Crapo Process to insure a uniform, tightly adherent zinc coating which provides lasting protection against corrosion. Regularly furnished in No. 12 B.W.G. and in continuous lengths without splices and joints. Physical and electrical characteristics are as follows:

Nominal diameter, 0.109 inches. Minimum breaking strength, 1213 pounds. Resistance, 38.23 ohms per mile. Approximate weight per mile, 170 pounds. Approximate weight per coil, 150 pounds. Minimum weight per coil, approximately 140 pounds. Maximum weight per coil, approximately 160 pounds. Approximate length per coil, 4659 feet. Minimum length per coil, approximately 4348 feet. Maximum length per coil, approximately 4970 feet.

Galvanized steel compression-type sleeves are recommended for splicing HTL-135 line wire.

No. 12 BWG Stock No. (893129)

**CRAPO GALVANIZED TIE WIRES**

Manufactured specially to facilitate tying in telephone line wire. Galvanized by Crapo Process. Furnished in coils or straightened and cut to length.

Standard bundle for horseshoe tie, 25 pounds.

Standard bundle for armor tie, 50 pounds.

**Crapo Galvanized Tie Wires**

**Standard Coils**

Size B.W.G.	Stock No.	Approx. Length Ft.	Approx. Wt. Lb.
10	(893109)	2040	100
12	(893110)	3100	100
14	(893111)	2650	50

**Straightened and Cut to Length**

**Horseshoe Tie**

Size B.W.G.	Stock No.	Length Inches	No. of Pieces
10	(893112)	18	350
10	(893113)	16	390
12	(893114)	14	675
14	(893115)	14	1150

**Armor Tie**

Size B.W.G.	Stock No.	Length Inches	No. of Pieces
10	(893116)	48	260
10	(893117)	46	270
12	(893118)	44	430
14	(893119)	40	810

## CRAPO DOUBLE GALVANIZED TELEPHONE AND TELEGRAPH WIRE



Crapo Galvanized Telephone and Telegraph Wire is a quality-controlled product manufactured in accordance with specifications based on sound research and years of actual experience. Each grade is drawn from iron, or steel, of specific analysis, processed under laboratory supervision, extra galvanized by

the Crapo Process, rigidly inspected. Such care and precision in manufacture guarantee to users line wire which meets rigid specifications for electrical conductivity, tensile strength, elongation, galvanizing and ductility.

Furnished in the following standard grades:

Size B.W.G.	Dia. In.	Nominal Wt.		Lgth. Coil Miles	B.B. Grade			E.B.B. Grade			Steel Grade		
		Mile	Lb. per Coil		Stock No.	Brk. Stgh. Lb.	Max. Resis. Ohms per Mile	Stock No.	Brk. Stgh. Lb.	Max. Resis. Ohms per Mile	Stock No.	Brk. Stgh. Lb.	Max. Resis. Ohms per Mile
4	.238	811	197	1/4	(893130)	2271	7.15	(893138)	2028	5.98	(893146)	2433	8.32
6	.203	590	191	1/3	(893131)	1652	9.83	(893139)	1475	8.22	(893147)	1770	11.44
8	.165	390	189	1/2	(893132)	1092	14.87	(893140)	975	12.43	(893148)	1170	17.31
9	.148	314	152	1/2	(893133)	879	18.47	(893141)	785	15.44	(893149)	942	21.50
10	.134	258	126	1/2	(893134)	722	22.48	(893142)	645	18.79	(893150)	774	26.16
11	.120	206	100	1/2	(893135)	577	28.16	(893143)	515	23.54	(893151)	618	32.77
12	.109	170	82	1/2	(893136)	476	34.12	(893144)	425	28.52	(893152)	510	39.71
14	.083	99	48	1/2	(893137)	277	58.59	(893145)	247	48.98	(893153)	297	68.18

## COPPERWELD TELEPHONE LINE WIRE

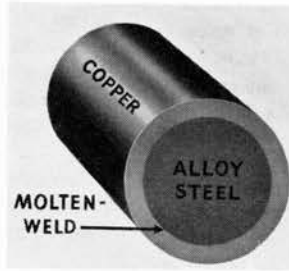

Copperweld Telephone Line Wire is designed to meet the requirements of modern low cost, reliable, long-span construction. Its long trouble-free life and high strength make it ideal for toll lines, exchange lines, rural lines, forestry lines, telephone circuits in conjunction with power transmission lines and for multi-channel carrier telephone and telegraph lines.

A thick, protective covering of copper molten-welded to a strong alloy steel core combines in Copperweld the best electrical and mechanical properties of both metals. The result is a conductor with these advantages some of which are found only in Copperweld.

1. Safety for long span construction.
2. Permanent strength to withstand heavy ice and wind loads.
3. Permanent protection against corrosion.
4. Greater tensile strength than any wires of comparable electrical properties.
5. Best electrical conductance of any high strength conductor.
6. Excellent transmission characteristics for voice and high frequency currents.

7. Ease of handling because of its pliability.
8. Low annual cost through long, trouble-free service.

### Physical and Electrical Properties

Size A.W.G. or In.	Stock No.	Diameter (Inch)	Breaking Strength (Lbs.)	
			High Strength 40% Conductivity	Extra High Strength
8	(894773)	.1285	1,660	—
.128	(894774)	.1280	1,647	—
9	(894775)	.1144	1,368	—
.104	(894339)	.1040	1,177	1,325
10	(894776)	.1019	1,130	—
12	(894777)	.08081	785	—
.080	(894778)	.080	770	—

Lbs. per 1000 Ft.	Weight Lbs. per Mile	Resistance Ohms Per 1000 Ft. at 68° F. 40% Conduct.	Cross-Section	
			Cir. Mils	Sq. In.
45.81	241.9	1.602	16,510	.01297
45.47	240.1	1.614	16,380	.01287
36.33	191.8	2.020	13,090	.01028
30.01	158.5	2.445	10,820	.008495
28.81	152.1	2.547	10,380	.008155
18.12	95.68	4.051	6,530	.005129
17.76	93.77	4.133	6,400	.005027



**CRAPO GALVANIZED STEEL GUY AND MESSENGER STRAND  
7 Wires Twisted into a Single Strand**

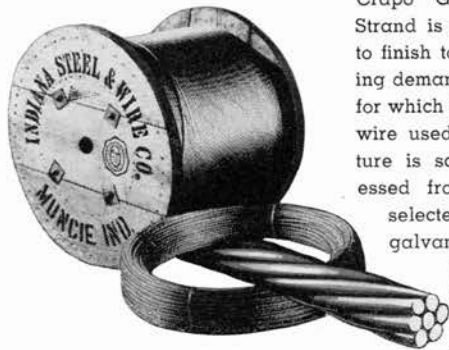

Crapo Galvanized Steel Strand is made from start to finish to meet the exacting demands of the service for which it is intended. All wire used in its manufacture is scientifically processed from the steel of selected analysis and galvanized by the Crapo Process. Each wire used in forming a particular size and

grade of strand is produced from the same special steel and processed in the same way, to insure uniformity. Both wire and strand are laboratory checked for tensile strength, elongation, galvanizing and ductility to make certain that the finished product conforms to the most rigid specifications.

Furnished in the following standard lengths: 3/8-inch diameter and smaller in 250, 500 and 1000-foot coils and 2500 and 5000-foot reels; 7/16-inch diameter and larger in 250 and 500-foot coils and 1000, 2500 and 5000-foot reels. When ordering specify size and grade, method of packing (coils or reels), and number of feet per coil or reel.



**Extra Galvanized—Extra High Strength Grade**

Nom. Diam. Strand In.	Stock No.	Wire Diam. In.	Wt. Lb. per 1000 Feet	Strength Pounds
5/8	(893391)	.207	813	42400
1/2	(893392)	.165	517	26900
7/16	(893393)	.145	399	20800
3/8	(893394)	.120	273	15400
5/16	(893395)	.104	205	11200
9/32	(893396)	.093	164	8950
1/4	(893397)	.080	121	6650
3/16	(893398)	.062	72.9	3990

**Western Union and A.T.&T. Specification Strand—Utilities Grade**

Nom. Diam. Strand In.	Stock No.	Wire Diam. In.	Wt. Lb. per 1000 Feet	Strength Pounds
1/2	(893399)	.165	517	25000
7/16	(893400)	.145	399	16000
3/8	(893401)	.120	273	10000
5/16	(893402)	.109	225	6000
9/32	(893403)	.093	164	4000
3/16	(893404)	.065	80.3	2200

**Single Galvanized Strand—Common Grade**

Nom. Diam. Strand In.	Stock No.	Wire Diam. In.	Lb. per 1000 Ft.	Strength Pounds
5/8	(893357)	.207	813	11600
1/2	(893358)	.165	517	7400
7/16	(893359)	.145	399	5700
3/8	(893360)	.120	273	4250
5/16	(893361)	.104	205	3200
1/4	(893362)	.080	121	1900
3/16	(893363)	.062	72.9	1150

**Extra Galvanized Strand—Common Grade**

Nom. Diam. Strand In.	Stock No.	Wire Diam. In.	Lb. per 1000 Ft.	Strength Pounds
5/8	(893366)	.207	813	11600
1/2	(893367)	.165	517	7400
7/16	(893368)	.145	399	5700
3/8	(893369)	.120	273	4250
5/16	(893370)	.104	205	3200
1/4	(893371)	.080	121	1900
3/16	(893372)	.062	72.9	1150

**Extra Galvanized—Siemens-Martin Grade**

Nom. Diam. Strand In.	Stock No.	Wire Diam. In.	Wt. Lb. per 1000 Feet	Strength Pounds
5/8	(893375)	.207	813	19100
1/2	(893376)	.165	517	12100
7/16	(893377)	.145	399	9350
3/8	(893378)	.120	273	6950
5/16	(893379)	.104	205	5350
9/32	(893380)	.093	164	4250
1/4	(893381)	.080	121	3150
3/16	(893382)	.062	72.9	1900

**Extra Galvanized—High Strength Grade**

Nom. Diam. Strand In.	Stock No.	Wire Diam. In.	Wt. Lb. per 1000 Feet	Strength Pounds
5/8	(893383)	.207	813	23300
1/2	(893384)	.165	517	13900
7/16	(893385)	.145	399	14500
3/8	(893386)	.120	273	10800
5/16	(893387)	.104	205	8000
9/32	(893388)	.093	164	6400
1/4	(893389)	.080	121	4750
3/16	(893390)	.062	72.9	2850

**COPPERWELD STRAND**

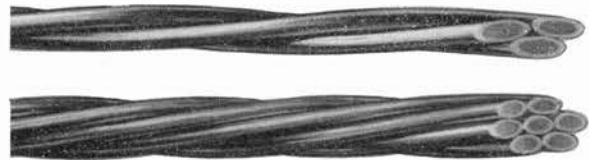

The long life and dependable performance of Copperweld Strand provides low cost insurance on all guying and messenger jobs. Since Copperweld won't rust, it is unnecessary to use a larger diameter strand to compensate for loss of strength in service. The original strength of Copperweld is retained. This high strength strand can be bent, served, moused or clamped with no danger of flaking, cracking or peeling. The molten-weld between the ductile copper and the high strength alloy steel core is strong and permanent.

Standard length coils or reels can be supplied as shown in the table. Other lengths can be furnished when specified. Orders should indicate desired method of packing.

**Physical Properties**

Nominal Diameter (Inch) Size A.W.G.	Stock No.	Actual Dia. (Inch)	Breaking Load (Lbs.)	
			High Strength	Extra High Strength
9/16 (7 No. 5)	(894786)	.546	20,470	24,650
1/2 (7 No. 6)	(894787)	.486	16,890	20,460
7/16 (7 No. 7)	(894788)	.433	13,910	16,890
3/8 (7 No. 8)	(894789)	.385	11,440	13,890
5/16 (7 No. 10)	(894790)	.306	7,758	9,196

  

Weight Lbs. per 1000 Ft.	Cross-Section Sq. In.	Ft. Per Lb.	Standard Packing	
			Reels Ft.	Coils Ft.
649.4	3.429	.1820	5,000&2,500	—
515.0	2.719	.1443	5,000&2,500	500
408.4	2.157	.1145	5,000&2,500	500
323.9	1.710	.09077	5,000&2,500	500
203.7	1.076	.05708	5,000&2,500	500



STROMBERG-CARLSON

# Insulators and Sleeves

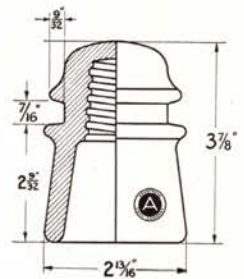

Dependable glass insulators to withstand the worst weather conditions; porcelain knobs and screw eyes; splicing equipment for those inevitable "breaks" caused by severe icing.

CONTENTS  
SECTION S

**INSULATORS AND SLEEVES**

---

	Page
Armstrong Glass Insulators.....	3s
Hemingray Glass Insulators .....	4s
Non-Breakable Insulators .....	5s
Porcelain Insulators .....	5s
Clevises and Forks .....	6s
Porcelain Wire Holders.....	7s
Service Wire Holders .....	8s
Double Tube Splicing Sleeves .....	8s
Nicopress Splicing Sleeves .....	9s
Reducing Sleeves .....	10s
Repair Sleeves .....	10s
Nicotap Sleeves .....	10s
Off-set Dead Ends .....	11s
Splicing Tools .....	12s

---

ARMSTRONG'S GLASS INSULATORS

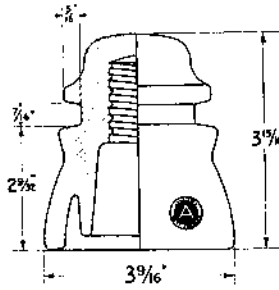

**NO. 1**  
**Side G. Double Petticoat**  
 Height Over All . . . . . in. 3 15/16  
 Diameter Over All . . . . . in. 3 9/16  
 Diameter Groove . . . . . in. 7/16  
 Quantity per Box . . . . . 40  
 Appr. Wt. per 1000 . . . . . lb. 1625  
 Stock No. (891187)

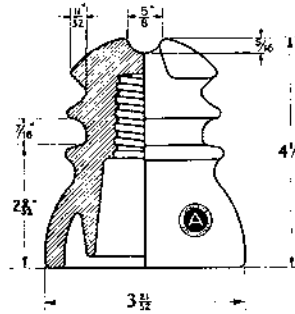

**NO. 10**  
**Top Groove D. P.**  
 Height Over All . . . . . in. 4 1/4  
 Diameter Over All in. 3 21/32  
 Diameter Groove . . . . . in. 7/16  
 Quantity per Box . . . . . 40  
 Appr. Wt. per 1000 lb. 1750  
 Stock No. (891191)

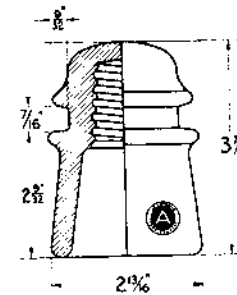

**No. 2**  
**Toll Line**  
 Height Over All . . . . . in. 3 7/8  
 Diameter Over All . . . . . in. 2 13/16  
 Diameter Groove . . . . . in. 7/16  
 Quantity per Box . . . . . 50  
 Appr. Wt. per 1000 . . . . . lb. 1080  
 Stock No. (891188)

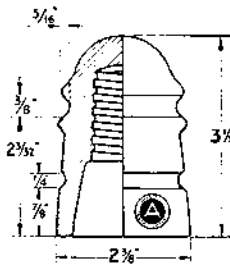

**NO. 13**  
**Double-Groove Pony**  
 Height Over All . . . . . in. 3 1/2  
 Diameter Over All . . . . . in. 2 3/8  
 Diameter Groove . . . . . in. 3/8  
 Quantity per Box . . . . . 50  
 Appr. Wt. per 1000 . . . . . lb. 640  
 Stock No. (891192)

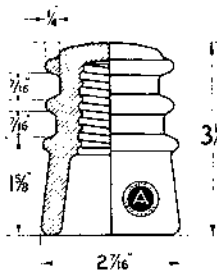

**NO. 3**  
**Exchange Line**  
 Height Over All . . . . . in. 3 1/4  
 Diameter Over All . . . . . in. 2 7/16  
 Diameter Groove . . . . . in. 7/16  
 Quantity per Box . . . . . 50  
 Appr. Wt. per 1000 . . . . . lb. 720  
 Stock No. (891189)

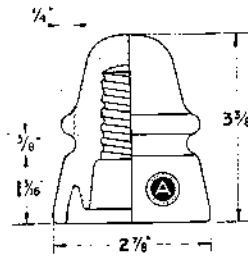

**NO. 14**  
**Dbl.G., D. P. Pony**  
 Height Over All . . . . . in. 3 3/8  
 Diameter Over All . . . . . in. 2 7/8  
 Diameter Top Groove . . . . . in. 3/8  
 Quantity per Box . . . . . 50  
 Appr. Wt. per 1000 . . . . . lb. 820  
 Stock No. (891193)

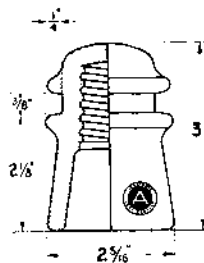

**NO. 9**  
**Pony**  
 Height Over All . . . . . in. 3 3/8  
 Diameter Over All . . . . . in. 2 5/16  
 Diameter Groove . . . . . in. 3/8  
 Quantity per Box . . . . . 50  
 Appr. Wt. per 1000 . . . . . lb. 620  
 Stock No. (891190)

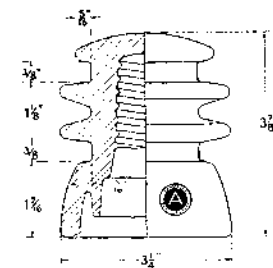

**TW**  
**One-Piece Trans.**  
 Height Over All . . . . . in. 3 7/8  
 Diameter Over All in. 3 1/4  
 Diameter Groove in. 3/8  
 Quantity per Box . . . . . 40  
 Approx. Wt. per 1000 . lb. 1600  
 Stock No. (894674)

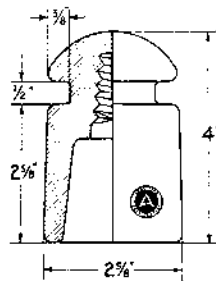

**CSC**  
**Carrier Service**  
 Height Over All . . . . . in. 4  
 Diameter Over All . . . . . in. 2 5/8  
 Diameter Groove . . . . . in. 1/2  
 Quantity per Box . . . . . 50  
 Appr. Wt. per 1000 . . . . . lb. 1120  
 Designed for mounting on a steel pin cushioned with a .016" lead thimble or approved equivalent.  
 Stock No. (891195)

## HEMINGRAY GLASS INSULATORS

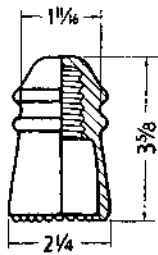

**NO. 9**  
**Pony**  
Height Over All .....in. 3 5/8  
Diameter Over All .....in. 2 1/4  
Diameter Groove .....in. 3/8  
Quantity per Box ..... 50  
Approx. Wt. per 1000 .....lb. 580  
Stock No. (891177)

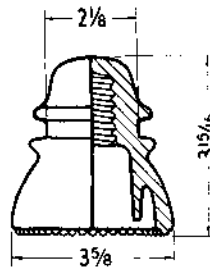

**NO. 42**  
**Double Petticoat**  
Height Over All .....in. 3 31/32  
Diameter Over All .....in. 3 3/4  
Diameter Groove .....in. 7/16  
Quantity per Box ..... 40  
Approx. Wt. per 1000 .....lb. 1550  
Stock No. (891182)

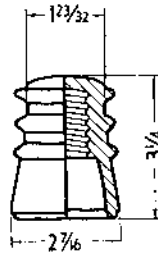

**NO. 10**  
**Exchange Line**  
Height Over All .....in. 3 1/4  
Diameter Over All .....in. 2 7/16  
Diameter Groove .....in. 7/16  
Quantity per Box ..... 50  
Approx. Wt. per 1000 .....lb. 690  
Stock No. (891178)

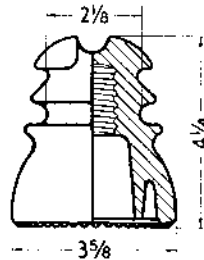

**NO. 43**  
**Top Groove W. U.**  
Height Over All .....in. 4 9/32  
Diameter Over All .....in. 3 3/4  
Diameter Groove .....in. 7/16  
Quantity per Box ..... 40  
Approx. Wt. per 1000 .....in. 1900  
Stock No. (891183)

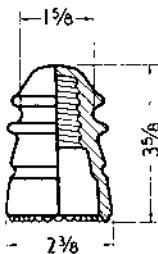

**NO. 12**  
**Double-Groove Pony**  
Height Over All .....in. 3 5/8  
Diameter Over All .....in. 2 3/8  
Diameter Top Groove .....in. 3/8  
Quantity per Box ..... 50  
Approx. Wt. per 1000 .....lb. 690  
Stock No. (891179)

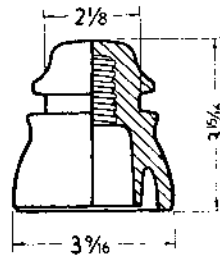

**NO. 45**  
**One-Piece Trans.**  
Height Over All .....in. 3 15/16  
Diameter Over All .....in. 3 9/16  
Diameter Groove .....in. 7/16  
Quantity per Box ..... 40  
Approx. Wt. per 1000 .....lb. 1625  
Stock No. (891184)

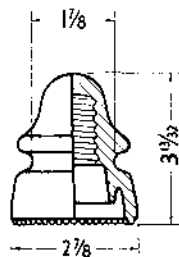

**NO. 14**  
**Deep G., D.P. Pony**  
Height Over All .....in. 3 13/32  
Diameter Over All .....in. 2 7/8  
Diameter Groove .....in. 3/8  
Quantity per Box ..... 50  
Approx. Wt. per 1000 .....lb. 810  
Stock No. (891180)

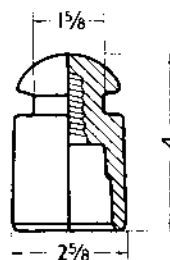

**NO. 22**  
**Point Transposition**  
Height Over All .....in. 4  
Diameter Over All .....in. 2 5/8  
Diameter Groove .....in. 1/2  
Quantity per Box ..... 50  
Approx. Wt. per 1000 .....lb. 1050  
Stock No. (894892)

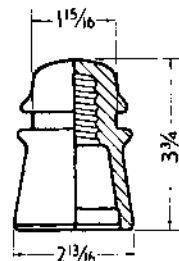

**NO. 16**  
**Long Distance**  
Height Over All .....in. 3 3/4  
Diameter Over All .....in. 2 13/16  
Diameter Groove .....in. 3/8  
Quantity per Box ..... 50  
Approx. Wt. per 1000 .....lb. 1070  
Stock No. (891181)

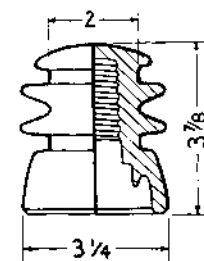

**NO. 56**  
**Point Transposition**  
Height Over All .....in. 3 7/8  
Diameter Over All .....in. 3 1/4  
Diameter Groove .....lb. 3/8  
Quantity per Box ..... 40  
Approx. Wt. per 1000 lb. 1475  
Stock No. (894893)

### Table of Comparable Pin Type Insulators

All comparisons are approximate, and not identical.

Brand Name	Number								
Whitall Tatum	1	2	3	9	10	13	14	15	C.S.C.
Hemingray	42x45	16	10	9	43	12	14	53x56	C.S.C.

**TYPE R-3 NON-BREAKABLE INSULATORS**

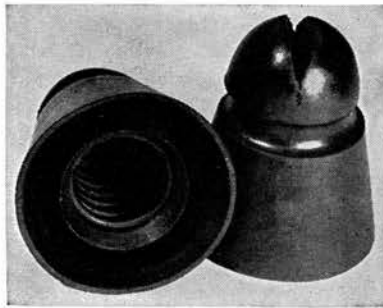

The insulator is designed for wood pins and with a wood cob may also be used on steel pins; ties are not necessary. Due to a specially designed groove in the top of the insulator the line wire can be held in position without the need for a tie wire except at corners. The insulator should be reinforced with tie wire and a side tie used on corners.

Under both dry and wet weather conditions the insulation is fully equal to glass. The rubber compound is impregnated with a wax like substance which tends to prevent moisture from forming leakage paths.

Field tests over a period of six years indicate that the rubber compound of which the insulator is made will have a life of at least ten years under most severe conditions. The insulators will withstand repeated blows from stones and rifle bullets and will maintain the wires in place even though lacerated by gun shot.

The standard package contains 100 insulators.

Stock No. (894675)

**PORCELAIN STRAIN INSULATORS**

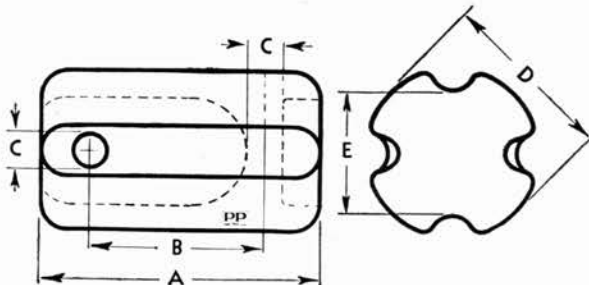

**Dry Process**

Cat. No.	Stock No.	Dimensions, Inches					Std. Wt. Lb. Pkg. per 100
		A	B	C	D	E	
500	(891237)	2 3/8	1	3/8	1 9/16	1 1/16	100 24
502	(891238)	3 1/2	1 3/4	5/8	2 1/2	1 3/4	50 128
504	(891239)	4 1/4	2 1/4	7/8	2 7/8	2 1/8	36 178
506	(891240)	5 3/8	3 1/8	1	3 3/8	2 3/8	25 368

**Wet Process**

Cat. No.	Stock No.	Dimensions, Inches					Std. Wt. Lb. Pkg. per 100
		A	B	C	D	E	
500	(894137)	2 3/8	1	3/8	1 9/16	1 1/16	100 24
502	(894138)	3 1/2	1 3/4	5/8	2 1/2	1 3/4	50 128
504	(894139)	4 1/4	2 1/4	7/8	2 7/8	2 1/8	36 178
506	(894140)	5 3/8	3 1/8	1	3 3/8	2 3/8	25 368

**STANDARD PORCELAIN TELEPHONE KNOBS**

**Single Groove**



No. 4-SG  
(891196)



Type S  
(891197)

Catalog No.	4-SG	S
Height	1 11/16 inches	1 1/16
Diameter	1 1/2 inches	1 5/8
Hole	3/8 inches	3/8
Groove	3/8 inches	7/16
No. per Barrel	2000	2500
Weight per 1000	230 pounds	150

**Double Groove**



No. 4-2GR  
(891199)



No. 6061  
(891200)



Type T  
(891201)



Type C  
(891202)

Catalog No.	4-2GR	6061	T	C
Height	1 11/16 in.	1 7/16	1 13/16	1 1/4
Diameter	1 1/2 in.	1 5/8	1 5/8	3/4 x 1 3/16
Hole	3/8 in.	3/8	7/16	7/32
Groove	5/16 in.	5/16	7/16	9/32
No. per Barrel	2000	1900	1500	5000
Weight per 1000	225 lb.	210	245	95

**FOUR-GROOVE TELO**



Catalog No.	6062
Stock No.	(891198)
Height	2 1/4 in.
Diameter	1 3/4 in.
Hole	7/16 in.
Groove	5/16 in.
No. per Barrel	1000
Weight per 1000	395 lbs.

**VICTOR PORCELAIN SPLIT INSULATORS**

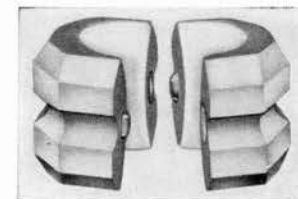

Catalog No.	22
Stock No.	(891203)
Height	1 5/8 in.
Diameter	2 5/8 in.
Hole	1 in.
Groove	5/16 in.
No. per Barrel	1250
Weight per 1000	332 lbs.

## PORCELAIN TUBES



Lgth. Under Head Inches	Stock No.	5/16" I.D. Tubes per Barrel	9/16" O.D. Wt. Lb. per 1000
2	(891207)	7000	45
2 1/2	(891208)	5500	58
3	(891209)	4500	62
4	(891210)	3600	80
5	(891211)	2900	100
6	(891212)	2000	118
		3/8" I.D.	1 1/16" O.D.
2 1/2	(891213)	4000	57
3	(891214)	3100	107
4	(891215)	2300	117
5	(891216)	1900	142
6	(891217)	1500	183

## ALLIGATOR NAIL KNOBS

For providing insulating support in interior wiring, both open and concealed.

It is simple, economical, dependable, and safe.

Made of hard vitrified porcelain, either glazed or unglazed, assembled with 12d nails.

The nail is held in position by a steel washer, which eliminates weakening or bending the nail. The nail head is thoroughly cushioned with a leather washer to prevent breakage.



Height, 1 3/4 inches. Diameter, 1 1/8 inches.  
Size of wire, 12-14.  
Quantity per barrel, 2700.  
Shipping weight per 1000, 165 pounds.  
Stock No. (891206)

## INSULATED SCREW EYES Hot-Dip Galvanized

The porcelain ring has a diagonal opening which allows the easy insertion of wires and when pulled taut they cannot become released from the ring.

The porcelain is glazed on the interior surface of the ring and on the surfaces of the slot.

Opening 9/32 inch; Steel 1/4 inch.

Type In.	Stock No.	Size Eye In.	Length Shank In.	Wt. Lb. per 1000
5/8-S	(891232)	5/8	1	85
5/8-L	(891233)	5/8	2	95
1-S	(891234)	1	1 1/8	180
1-L	(891235)	1	2 1/8	190

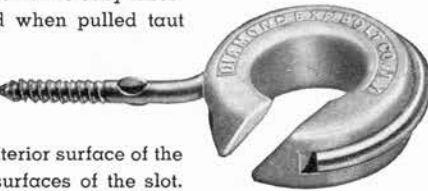

## PEIRCE INSULATED TELEPHONE KNOB SCREWS Hot Galvanized No. 2920

May be used for dead-ending duplex or twisted pair telephone wires. Also as a service attachment for low voltage power lines in localities not visited by snow and sleet.

Provided with large brown glaze insulator No. 2927. Overall length, 4 1/4 inches. Size screw, No. 22x2 1/2 inches. With Insulators, Shipping Weight 48 Pounds.

Catalog No. 2920, Stock No. (891236)



## C. B. KNOB FOR DROP WIRES



Used for telephone services. It is fastened to the building with a bridle ring, providing a flexible fixture.

Wire bail is hot galvanized.

Width 1 7/16"; Diameter 1 3/8"; Width of groove 5/16"; Size of clevis .169"; Weight per 100, 190 lbs.

Catalog No. J1648 Stock No. (891204)

## SELF-TYING KNOBS

Requires no tie wires, brackets, angle irons or bolts. The drop wire can be led in from any angle and pulls directly against the screw.

Made from white glazed porcelain.

Weight per 1000, 450 pounds.

Stock No. (891205)



## ANGLE SCREWS

### Intergalvanized

### Furnished Less Knobs

For attaching knobs for drop wiring on wood or stone structures.

Cat. No. ....	5/16	3/8
Stock No. ....	(891230)(891231)	
Diam. Wire .....	5/16	3/8
Lgth. Screw .....	1 3/4	2
Lgth. Shank .....	2 1/4	3 1/2
Std. Pkg. ....	100	100
Wt. Std. Pkg. ....	15	20

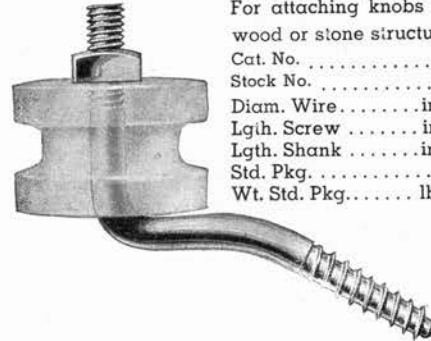

## HUBBARD INSULATED CLEAVISES

### Hot Galvanized

Catalog No. 641, with Insulators.

The No. 641 style Clevis is formed from 1/8" x 1/2" x 1 1/4" channel steel and uses a No. 357 Insulator. Attachment is made by a 5/8" bolt through the 1 1/16" mounting hole.

Shipping weight, 131 pounds per 100.

Catalog No. 641, Stock No. (891248)

Catalog No. 8820, with Insulators.

Formed of flat steel.

Has 1 1/16-inch round mounting hole for 5/8-inch mounting bolts.

Uses No. 357 dry process insulator.

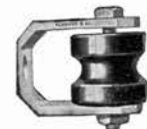

Channel Size .....	inches	1/8 x 1/2 x 1 1/4
Mounting Hole Size .....	inches	1 1/16 sq.
Shipping Weight, 100 pieces .....	lbs.	130

Catalog No. 8820, Stock No. (891249)

Catalog No. 561, with Insulators.

Formed of 1 1/2 x 1/16-inch channel steel.

A sturdy dead-end or corner attachment. Used with No. 355 dry process insulator for low voltage lines.

Oval mounting hole, 1 1/16 x 2 5/32 inches. Shipping weight, 278 pounds per 100.

Catalog No. 561, Stock No. (891250)

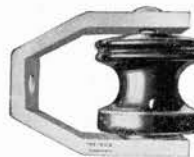

**HUBBARD DEAD END BRACKETS**  
Hot Galvanized

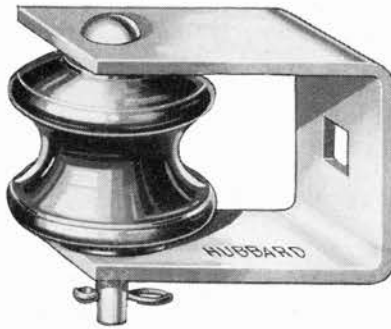

No. 2944

Hubbard Dead End Brackets are standard for telephone construction. The 1 1/2" x 1/8" flat steel bracket is furnished with a 13/32" square mounting hole. The No. 2944 covers one dead end bracket complete with one No. 1663 Porcelain Insulator. This insulator, which may be

ordered separately for replacements, is 1 5/8" high, 2" in diameter and has a 7/16" diameter mounting hole.

Catalog No.	Stock No.	Extension Pole to Center Insul.	Shipping Wt. Lbs. per 100
2944	(894864)	2 1/4"	79

**HUBBARD INSULATED CLEVISES**

Made from No. 7 ga. x 1 1/2" flat steel No. 1343 uses a No. 1606 dry process insulator and is attached by a 5/8" machine bolt through the 1 1/16" dia. mounting hole.

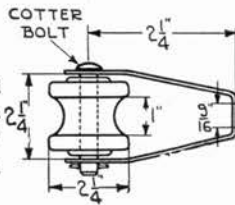

Steel Size ..... inches No. 7 ga. x 1 1/2"  
Mounting Hole Size ..... inches 1 1/16" dia.  
Shipping Weight, 100 pieces ..... lbs. 154

Catalog No. 1343 Stock No. (891247)

**HUBBARD INSULATED FORK BOLTS**  
Type No. 1  
Hot Galvanized



Equipped with insulator No. 357.

Catalog No. ....	8810	8811	8812
Stock No. ....	(891241)	(891242)	(891243)
Length of Bolt ..... inches	7 13/16	9 13/16	11 13/16
Diameter ..... inches	1/2	1/2	1/2
Ship. Wt. per 100 pieces ..... lbs.	191	205	218
Catalog No. ....	8813	8814	8815
Stock No. ....	(891244)	(891245)	(891246)
Length of Bolt ..... inches	9 13/16	11 13/16	13 13/16
Diameter ..... inches	5/8	5/8	5/8
Ship. Wt. per 100 pieces ..... lbs.	213	226	247

**DISTRIBUTING KNOB RACKS**  
Hot Galvanized

For running twisted pair telephone wires along poles and attaching service take-off wires.

Made up of two solid steel points, or eyes, securely riveted to a 1 3/4 x 5/8 x 1/8-inch channel back. No. 9214 knobs are included with this rack. Rack bolts for these knobs are 3/8-inch in diameter, threaded at the lower end.

Rack is mounted by means of 1/2-inch lag screws through 7/16-inch holes in each end. Extension from pole to the center of the insulators is 2 3/8 inches.

Spacing between corresponding grooves of adjacent insulators, or between insulator centers is 1 1/2 inches.



Cat. No.	Stock No.	No. of Knobs	Length Over All Inches	Approx. Ship. Wt. Lb. per 100 Pcs.
2900	(891218)	4	10 5/8	308
2901	(891219)	6	13 3/4	418
2902	(891220)	8	16 7/8	511

**PORCELAIN KNOBS FOR TELEPHONE RACKS**

**Dry Process Porcelain**



Made of brown glazed dry process porcelain.

Wire groove is divided by a fin which keeps the two wires of the twisted pair separated.

Cat. No.	Stock No.	Wire Groove Inches	Bolt Hole Inches	Height Inches	O.D. In.	Approx. Ship. Wt. Lb. per 100
9214	(891221)	3/4	25/64	1 1/2	1 3/4	25

**WIRE HOLDERS**

**All-Porcelain Type**  
Single and Double Groove



No. 1621  
Single Groove



No. 1622  
Double Groove

Combines a wall bracket, insulator and screw all in one. A jab and a few turns is all that is necessary to install it. Designed so that no metal is exposed after installation.

The special wood screw which is a part of this wire holder has a clean cut thread and a point which starts into the wood under very little pressure.

Packed 50 in a standard package.

Cat. No.	Stock No.	Size of Screw, In.	Size Wire Hole, In.	Wt. Lbs. per 100
1621	(891254)	20x2 1/8	5/8	65
1622	(891255)	20x2	7/16 x 3/4	65

## SERVICE WIRE HOLDERS

Designed for long service. Made of porcelain. All corners are rounded. Screws have sharp threads and are leaded solidly into the porcelain.

All steel screws are hot galvanized.

Size hole of holder No. J1955,  $\frac{1}{2}$  x  $\frac{3}{4}$  inches; Diameter of porcelain at base  $1\frac{1}{8}$  inches; Height of porcelain,  $2\frac{7}{8}$  inches.



No. J1955



No. J1960

Size hole of holders J1960, J1961, J1965, J1976,  $\frac{7}{8}$  inches; Diameter of porcelain at base  $2\frac{1}{2}$  in.; Height of porcelain  $3\frac{1}{8}$  in.

Cat. No.	Stock No.	Insulator Mounted on	Wt. Lb. per 100
J1955	(891256)	Galv. Steel Screw	65
J1960	(891257)	Galv. Steel Screw	95
J1961	(891258)	Brass Screw	95
J1965	(891260)	Galv. Carriage Bolt	107
J1976	(891261)	Galv. Toggle Bolt	105

## NO. J-089 SERVICE WIREHOLDERS

The No. J-089 Wireholder is unequalled for rugged construction, attractive appearance, and ease of installation. Equal strength on dead end or 45° pull. All steel parts are hot dip galvanized; all edges on the porcelain insulator are well rounded and will not chip even though a steel bar is used as a handle to install the wireholder.



Cat. No.	Stock No.	Screw Size & Length	No. in Pkg.	Wt. per 100
J-089	(894771)	22x2 $\frac{1}{4}$ "	50	75 lb.

## DOUBLE TUBE SPLICING SLEEVES



For straight line splices. Use copper sleeves for copper wire and tinned copper or tinned steel for iron wire. Use B & S gage for size of copper sleeves and B.W.G. gage for size of tinned copper or tinned steel sleeves. Combination sleeves can be furnished in standard sizes.

### D. T. Plain Copper Sleeves

For Splicing Copper Line Wires

Number of Turns, $3\frac{1}{2}$ .	Gage, B & S Solid	Stock *No.	Stock †No.	Comparable Gage B.W.G.	Full Lgth. In.	Half Lgth. In.	Ship. Wt. Lb. per M Full Lgth.
6	(893154)	(893163)	8	6 $\frac{3}{4}$	3 $\frac{3}{8}$		118
7	(893155)	(893164)	9	5 $\frac{3}{4}$	2 $\frac{7}{8}$		93
8	(893156)	(893165)	10	5 $\frac{1}{2}$	2 $\frac{3}{4}$		68
Number of Turns, 3.							
9	(893157)	(893166)	11	5 $\frac{1}{4}$	2 $\frac{5}{8}$		60
10	(893158)	(893167)	12	4 $\frac{3}{4}$	2 $\frac{3}{8}$		35
12	(893159)	(893168)	14	4 $\frac{1}{2}$	2 $\frac{1}{4}$		29
Number of Turns, 4.							
14	(893160)	(893169)	16	4	2		20
16	(893161)	(893170)	18	4	2		20
17	(893162)	(893171)	—	4	2		17

\*Stock No. for Full Length Sleeves  
†Stock No. for Half Length Sleeves

### D. T. Tinned Copper Sleeves

For Splicing Galvanized Iron Line Wire

Gage B.W.G.	Stock *No.	Stock †No.	Comparable Gage B & S	Full Lgth. In.	Half Lgth. In.	No. Turns	Ship. Wt. Lb. per M Full Lgth.
12	(894180)	(893187)	10	4 $\frac{3}{4}$	2 $\frac{3}{8}$	3	35
14	(894181)	(893188)	12	4 $\frac{1}{2}$	2 $\frac{1}{4}$	3	29
16	(894182)	(893189)	14	4	2	4	20

\*Stock No. for Full Length Sleeves  
†Stock No. for Half Length Sleeves

### D. T. Tinned Steel Sleeves

For Splicing Galvanized Iron Line Wire

Number of Turns, 3.	Gage BWG	Stock *No.	Stock †No.	Full Lgth. In.	Half Lgth. In.	Ship. Wt. Lb. per M Full Lgth.
9	(893173)	(893179)		5 $\frac{3}{4}$	2 $\frac{7}{8}$	68
10	(893174)	(893180)		5 $\frac{1}{2}$	2 $\frac{3}{4}$	53
12	(893175)	(893181)		4 $\frac{3}{4}$	2 $\frac{3}{8}$	38
14	(893176)	(893182)		4 $\frac{1}{2}$	2 $\frac{1}{4}$	30

\*Stock No. for Full Length Sleeves  
†Stock No. for Half Length Sleeves

**NATIONAL NICOPRESS SPLICING SLEEVES**  
For Communication Lines

In the making of a Nicopress splice, the sleeves which are lined with a metal alloy, harder than the metal of either sleeve or conductor, are pressed onto the conductors with the special Nicopress tool. The hard alloy is forced onto the softer metals of sleeve and conductor. The resultant joint has a strength that is greater than the rated breaking strength of the conductor, and is so tight that the conductor cannot pull out.

Nicopress splices will withstand the toughest strains of vibration and have a high lasting conductivity.

**For Drop, Bridle and Inside Wires**

Splices made with Nicopress sleeves have maximum strength and tightness, are small, compact, and neat. There is a saving of wire and tape due to the fact that the wires are butted and not overlapped. Splicing is quickly done with the light, compact, one-hand-operated No. 17 type tool, completely eliminating need of solder.



Completed Drop Wire Splice



Completed Inside Wire Splice

Cat. No.	Stock No.	For Wire	For Use in Tool No.	Ship. Wt. per 200
3-036A	(893201)	19-20-22 B. & S. Copper	17-2	1/2 Lb.
3-045B	(893202)	17-18 A.W.G. Copperweld	17-2	3/4 Lb.
		17 B. & S. Bronze		
		17-18 B. & S. Copper		
3-051B	(893203)	16 B. & S. Copper	17-2	3/4 Lb.
		16 A.W.G. Copperweld		
3-064B	(893204)	14 B. & S. Copper	17-2	3/4 Lb.
4-049B	(893205)	18-19 B.W.G. Galv. Iron	17-2	3/4 Lb.

**For Hard Drawn Copper Wire Copper Sleeves**

Cat. No.	Stock No.	B. & S. Gage	N.B.S. Gage	For Use in Tool Groove	Ship. Wt. per 100
1-064C	(893206)	14	16	C	1 1/2
1-080C	(893207)	12	14	C	1 1/2
1-080D	(893208)	*12	14	D	1 1/2
1-102C	(893211)	10	12	C	1 1/4
1-102D	(893212)	*10	12	D	1 1/2
1-114D	(893215)	9	11	D	1 1/2
1-128E	(893218)	8	10	E	1 1/2
1-128J	(893219)	*8	10	J	4 1/2
1-162J	(893220)	6	8	J	4 1/2

\*Indicates sleeve with larger than standard outside diameter for use in a larger tool groove.

**For "BB" Galvanized Wire**

Catalog No.	Stock No.	B.W.G.	For Use in Tool Groove	Ship. Wt. Lbs. per 100
<b>Galvanized Steel Sleeves</b>				
5-083C	(893221)	14	C	1 1/2
5-109C	(893222)	12	C	1 1/2
5-109DBB	(893223)	*12	D	1 3/4

**Galvanized Copper Sleeves**

2-083C	(893227)	14	C	1 1/2
2-083D	(893228)	*14	D	1 3/4
2-109D	(893229)	12	D	1 3/4
2-134J	(893230)	10	J	2
2-148J	(893231)	9	J	4 1/2
2-165J	(893232)	8	J	4 1/2

**Galvanized Bronze Sleeve**

4-109C	(893233)	12	C	1 1/4
--------	----------	----	---	-------

**For "85" Galvanized Wire**

**Galvanized Steel Sleeves**

5-083C	(893221)	14	C	1 1/2
5-109DB5	(893235)	12	D	2

**Galvanized Copper Sleeves**

2-083C	(893227)	14	C	1 1/2
2-083D	(893228)	*14	D	1 3/4
2-134J85	(893240)	10	J	4 1/2
2-148J	(893231)	9	J	4 1/2

**For "135" Galvanized Wire**

**Galvanized Steel Sleeve**

5-109D135	(893242)	12	D	3
-----------	----------	----	---	---

**For Rusty Iron Wire**

**Galvanized Copper Sleeves**

2-102C	(893243)	12	C	1 3/4
--------	----------	----	---	-------

\*Indicates sleeve with larger than standard outside diameter for use in larger tool groove.

**For Copperweld Wire Telephone and Telegraph Sizes**

Solid—high strength and extra high strength.

Catalog No.	Stock No.	A.W.G.	Tool Groove	Ship. Wt. Lb. per C
1-064C	(893206)	14	C	1 1/2
1-080D	(893208)	12	D	1 1/2
1-080E	(893209)	*12	E	2 1/2
1-102J	(893214)	10	J	5 1/2
1-114J	(893217)	9	J	5 1/2

\*Indicates sleeve with larger than standard outside diameter for use in larger tool-groove.



Sleeve



Completed Splice

## NICOPRESS REDUCING SLEEVES

### Copper Sleeve

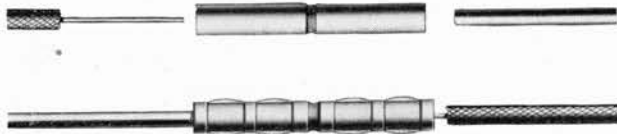

### For Copper Wire

Catalog No.	Stock No.	B. & S. Gage	For Use in Tool Groove	Approx. Ship. Wt. per 100
2-045x036B	(893309)	17, 18 to 19, 20, 22	17-2	1/2
1-064x036C	(893310)	14 to 19, 20, 22	C	1 1/2
1-064x045C	(893311)	14 to 17, 18	C	1 1/2
1-080x036C	(893312)	12 to 19, 20, 22	C	1 1/2
1-080x045C	(893313)	12 to 17, 18	C	1 1/2
1-080x051C	(893314)	12 to 16	C	1 1/2
1-080x064C	(893315)	12 to 14	C	1 1/2
1-102x036C	(893316)	10 to 19, 20, 22	C	1 1/2
1-102x045C	(893317)	10 to 17, 18	C	1 1/2
1-102x051C	(893318)	10 to 16	C	1 1/2
1-102x064C	(893319)	10 to 14	C	1 1/2
1-102x080C	(893320)	10 to 12	C	1 1/2
1-114x036D	(893322)	9 to 19, 20, 22	D	1 3/4
1-114x045D	(893321)	9 to 17, 18	D	1 3/4
1-114x051D	(893323)	9 to 16	D	1 3/4
1-114x064D	(893324)	9 to 14	D	1 3/4
1-114x080D	(893325)	9 to 12	D	1 3/4
1-114x102D	(893326)	9 to 10	D	1 3/4
1-128x051E	(893327)	8 to 16	E	2
1-128x064E	(893328)	8 to 14	E	2
1-128x080E	(893329)	8 to 12	E	2
1-128x102E	(893330)	8 to 10	E	2
1-128x114E	(893331)	8 to 9	E	2
1-162x064J	(893332)	6 to 14	J	3 1/2
1-162x102J	(893333)	6 to 10	J	2 1/2
1-162x114J	(893335)	6 to 9	J	3 1/4
1-162x128J	(893336)	6 to 8	J	3 1/4

### For Galvanized "BB" Line Wire

Cat. No.	Stock No.	B.W.G.	For Use in Tool Groove	Approx. Ship. Wt. per 100
4-109x083C	(893339)	12 to 14	C	1 1/2
2-109x083D	(893340)	12 to 14	D	2
2-134x083J	(893341)	10 to 14	J	3
2-134x109J	(893342)	10 to 12	J	3
2-148x109J	(893343)	9 to 12	J	5

### For Galvanized Line Wire to Drop, Bridle, and Inside Wires

Cat. No.	Stock No.	B.W.G. to B. & S.	For Use in Tool Groove	Approx. Ship. Wt. per 100
2-083x036C	(893344)	14 to 19, 20, 22	C	1 1/2
2-083x045C	(893345)	14 to 17, 18	C	1 1/2
2-083x051C	(893346)	14 to 16	C	1 1/2
4-109x045C	(893347)	12 to 17, 18	C	2
2-109x045D	(893348)	12 to 17, 18	D	2
4-109x051C	(893349)	12 to 16	C	2
2-109x051D	(893350)	12 to 16	D	2
4-109x064C	(893351)	12 to 14	C	2
2-109x064D	(893352)	12 to 14	D	2
2-134x051J	(893353)	10 to 16	J	5
2-134x064J	(893354)	10 to 14	J	4 3/4
2-148x064J	(893355)	9 to 14	J	5 1/2
2-165x064J	(893356)	8 to 14	J	5 1/2

## NICOPRESS REPAIR SLEEVES

### For Replacing Defective Joints



### For Copper Wire

Catalog No.	Stock No.	B. & S. Gage	For Use in Tool Groove	Lgth. In.	Approx. Ship. Wt. per 100
R1-080C	(893296)	12	C	7	6
R1-080D	(893297)	*12	D	7	7 1/2
R1-102C	(893298)	10	C	7 1/2	5 1/4
R1-114D	(893299)	9	D	8	7
R1-114E	(893300)	*9	E	8	9
R1-128E	(893301)	8	E	8	8 1/2
R1-162J	(893302)	6	J	10	16 1/2

\*Indicates sleeve with larger than standard outside diameter for use in a larger tool-groove.

### For "BB" Galvanized Wire

Catalog No.	Stock No.	B.W.G. Gage	For Use in Tool Groove	Lgth. In.	Approx. Ship. Wt. per 100
R2-083C	(893303)	14	C	7	6
R4-109C	(893304)	12	C	7 1/2	5 1/2
R2-109D	(893305)	*12	D	7 1/2	7
R2-134J	(893306)	10	J	8 1/2	16 1/2
R2-148J	(893307)	9	J	9	16
R2-165J	(893308)	8	J	10	16 1/2

\*Indicates sleeve with larger than standard outside diameter for use in a larger tool-groove.

## NICOTAP SLEEVES

Here is a new sleeve of special shape and design, manufactured to meet an insistent demand for a Nicopress Sleeve that would increase efficiency in making tap off connections.

The Nicotap is split its entire length so that there is no need of cutting the line to make the connection—just slip the sleeve over the line wire and compress.

Completed connections are strong and tight, quickly made and efficient.

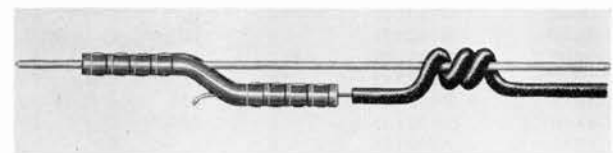

Nicotaps are now available in eight sizes: some are used for tap-offs with copper wire, some for tap-offs with steel wire, and the other four are reducing sizes for tapping-off one wire with another wire of different material or gage.

Catalog No.	Stock No.	Wire Size
T2-045B	(894052)	17, 18 B & S to 17, 18 B & S
T2-109D	(894053)	12 B.W.G. to 12 B. W. G.
T2-109 X045D	(894054)	12 B. W. G. to 17 or 18 B & S
T2-109x083D	(894873)	12 BWG to 14 BWG
T2-083C	(894874)	14 BWG to 14 BWG
T2-083x045C	(894875)	14 BWG to 17 or 18 B&S
T1-080C	(894876)	12 B&S to 12 B&S
T1-080x045C	(894877)	12 B&S to 17 or 18 B&S

**NICOPRESS OFFSET DEAD-ENDS**  
For Communication Lines

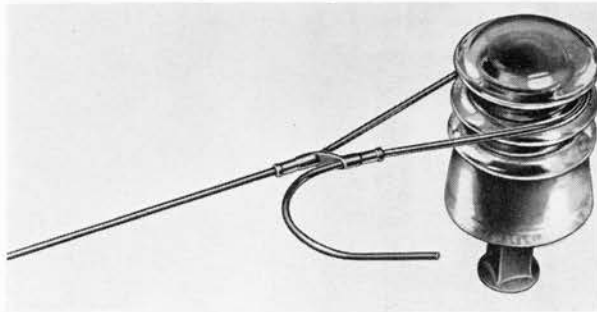

Completed Dead-End

The outstanding advantages secured through the use of the Nicopress method of dead-ending are: simplicity and speed of installation . . . maximum tightness and strength of completed dead-ends . . . the remarkable degree to which they withstand vibration . . . the provision for a tail of any desired length . . . the fact that no special tools are needed as work is done with same tool used for making Nicopress line splices.



Offset Dead-End Sleeve

**For Copper Wire**

Cat. No.	Stock No.	B. & S. Gage	N.B.S. Gage	For Use in Tool	Shipping Wt. Lb. per 100
91-064C	(893252)	14	16	C	2
91-080C	(893253)	12	14	C	1½
91-080D	(893254)	*12	14	D	1¾
91-102C	(893257)	10	12	C	1½
91-102D	(893258)	*10	12	D	1½
91-114D	(890260)	9	11	D	1½
91-128E	(890263)	8	10	E	1½
91-128J	(890264)	*8	10	J	5½
91-162J	(890265)	6	8	J	4½

\*Indicates sleeve with larger than standard outside diameter for use in a larger tool-groove.

**For Copperweld Wire**

Catalog No.	Stock No.	A.W.G.	For Use in Tool Groove	Approx. Ship.Wt. per 100
91-064C	(893252)	14	C	2
91-080C	(893253)	12	C	1½
91-080D	(893254)	*12	D	1¾
91-102J	(893270)	10	J	5¾
91-114J	(893271)	9	J	5¼

\*Indicates sleeve with outside diameter larger than standard for use in larger tool-groove.

**NICOPRESS OFFSET DEAD-ENDS**  
For Communication Lines

Cat. No.	Stock No.	B.W.G.	Sleeve Material	For Use in Tool Groove	Approx. Ship. Wt per 100
----------	-----------	--------	-----------------	------------------------	--------------------------

**For "BB" Galvanized Wire**

94-109C	(893277)	12	Galv. Bronze	C	1½
95-109C	(893278)	12	Galv. Steel	C	1½
95-109DBB	(893279)	*12	Galv. Steel	D	1½
92-109D	(893280)	*12	Galv. Copper	D	1½
92-165J	(893285)	8	Galv. Copper	J	5

**For "85" Galvanized Wire**

95-083C	(893274)	14	Galv. Steel	C	1½
92-083C	(893275)	14	Galv. Copper	C	1½
92-083D	(893276)	*14	Galv. Copper	D	1½
95-109D85	(893290)	12	Galv. Steel	D	1¾
92-134J	(893281)	10	Galv. Copper	J	5½
92-148J	(893283)	9	Galv. Copper	J	5

**For "135" Galvanized Wire**

95-109D135	(893295)	12	Galv. Steel	D	2½
------------	----------	----	-------------	---	----

\*Indicates sleeve with outside diameter larger than standard for use in larger tool-groove.

**GRIP-FLEX 38 INSULATOR TIES**



Designed for use with Copperweld Telephone Line Wire, the Grip-Flex 38 Tie provides uniformity in construction. It eliminates the more common faults of hand wrapped ties which have been the causes of chafing and fatigue fracturing of conductors. The Grip-Flex 38 Tie holds the conductor securely to the insulator and reinforces the conductor over the entire length of the tie. Simple in design, the Grip-Flex 38 Tie is easy to apply.

**Specifications**

Line Wire Size A.W.G. or Inch	Wire Size Stock No.	Reinforcing Wire A.W.G.	Lgth. Inches	Binding Wire A.W.G.	Lgth. In.	Approx. Wt. Lb. Per 100 Ties
8	(894779)	7	15	10	24	14
.128	(894780)	7	15	10	24	14
9	(894781)	8	14	10	24	12
.104	(894782)	9	12	12	24	7
10	(894783)	9	12	12	24	7
12	(894784)	10	10	12	24	6
.080	(894785)	10	10	12	24	6

Standard package—100 complete units per bundle. When ordering Grip-Flex 38 Ties, size of line conductor should be specified. Each tie consists of one preformed hard-drawn Copperweld reinforcing wire and one annealed Copper weld binding wire, suitable for making a side tie on any standard type of insulator.

## NICOPRESS TOOLS

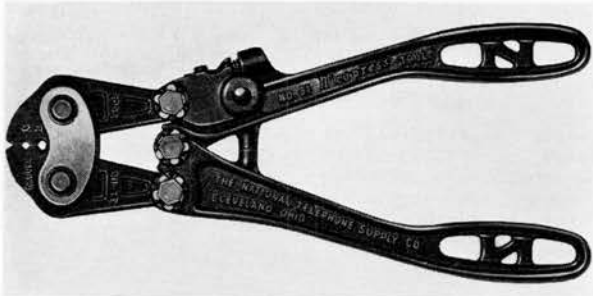

No. 31-DC

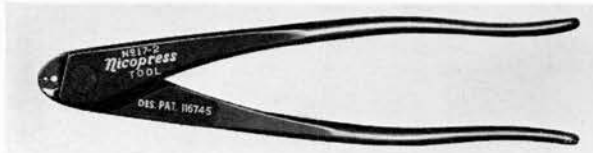

No. 17-2

In making the splice by the Nicopress method the tool must be of a size that is convenient and practical for the lineman to handle either in the air or on the ground. It must be so efficient in use that pressure can be applied with a certainty that each compression made will be exactly as required.

Catalog No.	Stock No.	Lgth. Tool Inches	No. of Grooves	Wt. Lbs. Each
17-2	(893190)	8	2	9/16
31-C	(893191)	11	1	1 7/8
31-D	(893192)	11	1	1 7/8
31-E	(893193)	11	1	1 7/8
31-J	(893194)	11	1	1 7/8
31-DC	(893195)	11 1/2	2	2
31-DJ	(893196)	11 1/2	2	2
31-CJ	(893197)	11 1/2	2	2

NOTE: Nicopress Tools are made with various sizes of die-grooves. Each die-groove is marked with a letter. The letter at the end of a sleeve stock number denotes the tool die-groove in which the sleeve should be compressed.

## TOOL HOLSTERS



No. 31



No. 17

A leather holster that may be carried on linemen's belts. Available for Nos. 17 and 31 type Nicopress Tools.

Catalog No. 17      Stock No. (893198)  
 Catalog No. 31      Stock No. (893200)

**STROMBERG-CARLSON**

# Tools

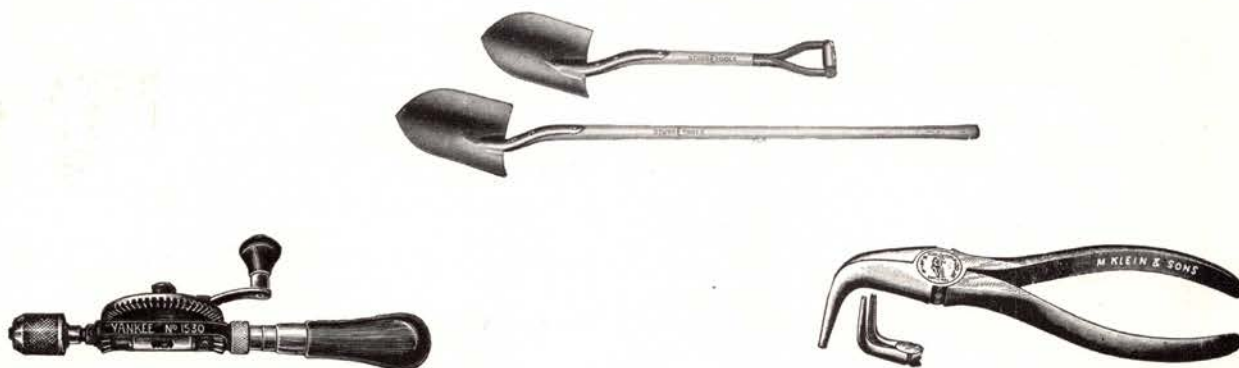

Small hand tools for easy maintenance; linemen's climbing and trimming outfits; tackles and jacks; meters and testing equipment; shovels and tamping bars for setting poles.

CONTENTS  
SECTION T

**TOOLS**

---

	Page
Tree Pruners .....	3t
Small Hand Pruners .....	4t
Hand Saws .....	5t
Digging and Tamping Bars .....	6t
Shovels .....	7t
Hooks and Pike Poles .....	9t
Raising Forks and Supports .....	10t
Reels and Ladders .....	11t
Pliers and Hand Tools .....	13t
Wire and Messenger Grips .....	16t
Pulling and Hoisting Equipment .....	17t
Climbing Equipment .....	20t
Tool Bags and Kits .....	25t
Small Hand Tools .....	26t
Rules and Measuring Tapes .....	33t
Power Tools .....	34t
Prest-O-Lite Linemen's Outfits .....	36t
Electrical Testing Equipment .....	37t

---

**SEYMOUR-SMITH NO. 12 AND NO. 111 TELEPHONE TREE PRUNERS**



Strong, durable tree pruners with reinforced head. Tempered steel cutting blade. Compression coil spring. Selected spruce poles with positive locking, seamless brass, telescoping ferrule joints. Steel cable chain works through ball bearing pulley. Simple, powerful action.

For heavy duty, up to 1½" capacity, the No. 12-18 Complete Pruner is recommended. Consists of No. 12 Pruner Head, No. 202 Head Section Pole, two No. 203 Extension Poles, and Operating Rope. For average work, up to 1" capacity, the No. 111-18 Complete Pruner is recommended. Consists of No. 111 Pruner Head, No. 102 Head Section Pole, two No. 103 Extension Poles, and Operating Rope.

Cat. No.	Stock No.	Description	Ship. Wt. Pounds
12-18	(892206)	Complete Pruner with rope, 18' pole	19
12	(892207)	Telephone Pruner Head only.	4
111-18	(892200)	Complete Pruner with rope, 18' pole	10
111	(892201)	Telephone Pruner Head only.	1½

Special Outfits May Be Made Up As Required (See Poles in Parts List).

For making up a very long pole, it is advisable to use the large Extension Section Poles (No. 203) for the lower sections. To join small poles to the large poles, it is necessary to use either the No. 21 Tapered Extension Section or the No. 51 Tapered Head Section Pole.

NOTE: One Head Section Pole must be a part of every outfit, to serve as a mounting for the Pruner Head and to receive the necessary extension sections.

**Repair Parts and Extra Poles**

Part No.	Part Name
121	Head Casting only
122	Operating Lever only
123	Lever Screw with Nut and Washer
124	Blade Bolt with Nut and Washer
125	Spring Bolt with Nut and 2 Washers
126	Spring with Eye Rod (2 needed per pruner)
127	Cutting Blade
128	Operating Pulley with Bolt and Nut
129	Socket Bolt with Nut
120	Operating Chain with Ring and Cotter Pin
200	Long Ferrule with Lock and Rivet
201	Short Ferrule with Rivet
202	Head Section Pole Complete, 6 ft. long
203	Extension Section Pole Complete 6 ft. long
*51	Tapered Head Section Pole, 6 ft. long
†21	Tapered Extension Pole 6 ft. long

**SEYMOUR SMITH "TELEPHONE" POLE PRUNING SAW**

**No. 20-18 Complete Saw**

An improved pole pruning saw for line clearing. Has unbreakable aluminum alloy head with extra large hook for pulling out loose branches. Also has paint brush holder. Saw blade 16" long of highest quality steel, taper ground, with fast-cutting needle teeth. Attached to head by bolt and thumb nut. Holes in blade end, which fit over a hardened steel screw, allow adjustment to three different positions. No weak pin to shear off.

No. 20-18 Complete Saw with 18 ft. pole. Comprised of No. 20 Saw Head, one Head Section 102, and two Extension Poles No. 103. Shipping Weight 10 lbs. Stock No. (894824)

**Repair Parts and Poles**

Part No.	Part Name
10B	Cutting Blade only
10S	Bolt, Wing Nut and Lock Washer
20H	Head Casting only
102	Head Section Pole 6 ft.
103	Extension Pole 6 ft.
*51	Tapered Head Section Pole 6 ft.
†21	Tapered Extension Pole 6 ft.

NOTE: When ordering parts, please specify both Part Number and Part Name. Special length, jointed pole sections for special purposes can be supplied. Prices on application.

\*If it is desired to use No. 111 Pruner Head with the large Extension Poles (No. 203) usually used with the No. 12 Telephone Tree Pruner, use a No. 51 Tapered Head Section for mounting Pruner Head.

†If it is desired to use No. 111 Pruner Head mounted on a small Head Section Pole (No. 102) and large Extension Sections (No. 203) as usually used with the No. 12 Telephone Tree Pruner, use a No. 21 Tapered Extension Section immediately below the small (No. 102) Head Section Pole.

**No. 20 Saw Head**

No. 20 Saw Head only with blade. Shipping weight 1½ lbs. Stock No. (894825)

\*If desired to use No. 20 Saw Head with large Extension Poles (No. 203) of No. 12 Telephone Tree Pruner, use a No. 51 Tapered Head Section for mounting Saw Head.

†A No. 20 Saw Head on a small Head Section Pole (No. 102) can be used with large Extension Sections (No. 203) by using a Tapered Extension Section (No. 21) in between.

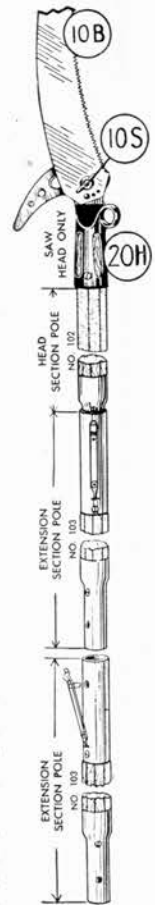

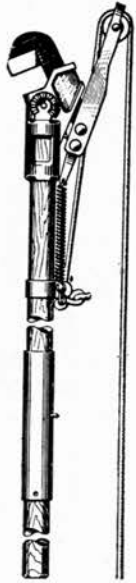

No. 700

## NO. 700 FEATHERWEIGHT TRIMMER

Our No. 700 Trimmer is designed for lighter work than the Nos. 800 and 900. It is a very light weight tool and yet makes a 1" cut, and is especially adapted for topping or work in the tree. This trimmer has single action pulley design. This is an ideal tool for home owners, nurseries, tree surgeons, park departments, etc.; unit of sale is head section and end section, 10' overall. Additional center section can be secured. All handles are 1 1/4" diameter. All pulleys are ball bearings for easier operation.

### Specifications

Cat. No. 700—10' Overall, weight 4 3/4 pounds.  
Stock No. (894621)

### Parts

Cat. No. 875—Center Ext. Handle 5', wt. 1 3/4 lbs.  
Cat. No. 750—Replacement Blade, wt. 3/8 lb.  
Cat. No. 885—End Ext. Handle 5', wt. 1 3/4 lbs.

## NO. 800 BANTAM WEIGHT TRIMMER

The Newman No. 800 Trimmer was designed for lighter work than the No. 900 would be used for and yet having the same compound leverage. This tool is light enough for horizontal use in the tree.

Cutting capacity a full inch and using 1 1/4" diameter handles. Unit of sale is 10' overall, consisting of head or cutting section 5' and end extension 5'. For longer use, 5' center extensions may be had. All pulleys are ball bearing for easier operation.

### Specifications

Cat. No. 800—10' Overall, weight 5 1/4 lbs.  
Stock No. (894622)

### Parts

Cat. No. 875—Center Ext. Handle 5', wt. 1 3/4 lbs.  
Cat. No. 750—Replacement Blade, wt. 3/8 lb.  
Cat. No. 885—End Ext. Handle 5', wt. 1 3/4 lbs.

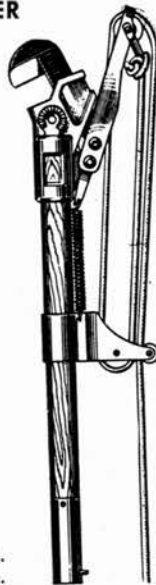

No. 800

## "EZY-CUT" LONG HANDLED PRUNER



A rugged performer for all tough clearing and brush cutting jobs. Drop forged, tempered steel cutting parts. Selected ash handles with heavy ferrules. Cuts up to 2" brush and limbs.

Cat. No.	Stock No.	Description
25	(892231)	22" handles, length overall 28"
26	(892232)	30" handles, length overall 36"

Packed 1 doz. in shipping carton. Shipping wts. per doz. No. 25, 53 lbs.; No. 26, 78 lbs.

## NO. 900 HEAVY DUTY TRIMMER



No. 900

This trimmer employs a wholly new principle in that it cuts from the top down rather than the bottom up—with the law of gravity rather than against it. Furthermore, the cutting action is a cyclic motion—point first, then heel—then the blade cleaves through the last of bark. This tool features the Newman compound leverage—plus ball bearing pulleys.

It is impossible to get this tool stuck or wedged in a limb—because there is no place for bark and sap to lodge.

Makes full 1 1/2" cut because cutting action is from outside in rather than inside out. All handles 1 1/2" diameter, 5' long. Unit of sale head section and end extension. 10' overall. Additional center sections may be had.

### Specifications

Cat. No. 900—10' Overall, weight 6 1/2 pounds.  
Stock No. (894623)

### Parts

Cat. No. 975—Center Ext. Handle 5', wt. 2 lbs.  
Cat. No. 950—Replacement Blade, wt. 1/2 lb.  
Cat. No. 985—End Ext. Handle 5', wt. 2 lbs.

## NO. 1550-2 XELA ELECTRICIANS' KNIVES

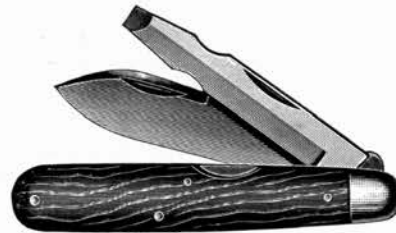

A handy combination for the electrician, combining an emergency screwdriver, a knife blade for cutting or stripping wire; safely locked so that it cannot close during use. Well-tempered blade, strong joint, solid, well-proportioned, hand fitting handle and a lock to keep the blade safely open, yet promptly releasable when it is desired to close the blades.

Screwdriver blade is locked when open; to unlock press down on large blade. Stock No. (892512)

## PROFESSIONAL PRUNER



Dual cutting action for close, clean quick-healing cuts. Branches, twigs; even frozen wood—will not slip from its blades, which are efficient to the tip. Tempered alloy steel forgings. Large center bolt and nut. Hard wood hand grips riveted to handles. Cuts 1 1/2" limbs. 28" overall.

Packed 1 doz. in shipping carton. Shipping wt. 33 lbs. per doz.

Catalog No. 528 Stock No. (892230)

**PRUNING SAWS**  
**No. 40—Tuttle Tooth**

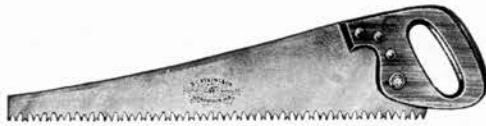

Special steel, high grade, tuttle tooth pattern. Has extra sharp teeth, which hold edge longer due to their extra fine temper. Handle of air dried beech, Davey pattern. Extra large and roomy grip reinforced with dowel pin. Fully lacquered and polished. Fastened to handle with 3 brass screws and medallion.

Packed 6 in a box.

Cat. No.	Stock No.	Lgth. Inches	Width Point In.	Width Butt Inches	Wt. Lb. per Doz.
40	(892236)	20	1 1/8	5 1/2	17
40	(892237)	24	1 1/2	6 1/4	21

**DOUBLE EDGED PRUNING SAWS**



No. 3 has Silver steel, specially hardened and tempered blade, noted for edge holding qualities. Toothed on one edge with lightning tooth for extra heavy coarse work, with fine tooth on opposite edge for finer cutting.

Thoroughly seasoned apple handle finely lacquered and polished and fastened to blade with 3 nickered screws.

No. 2 is similar to No. 3 except Sheffield quality. Packed 4 in a box.

Lgth. In.	Cat. No.	Stock No.	Points per In.	Width Point In.	Width Butt In.	Wt. Lb. per Doz.
18	3	(892234)	8 and Lightning	3/4	2 3/4	11
18	2	(892235)	8 and Lightning	3/4	2 3/4	11

**ATKINS AAA ALLOY STEEL NON-BREAKABLE HAND HACKSAW BLADES**



Packed 6 dozen in a box.

No. 300. For cutting cast iron, slate, machine steel, and other soft solid stock. Raker set. Stock No. (892241)

No. 310. For cutting iron, steel, brass and copper tubing; wrought iron pipe; drill rod; conduit; extra light structural

shapes; metal trim and sheet metal thicker than 18-gage. Raker or undulated set. Stock No. (892242)

No. 315. For cutting same materials as the No. 310 except thinner than 18-gage. Undulated set supplied regularly; alternate set when ordered. Stock No. (892243)

Lgth. *In.	Width In.	Thickness In.	Wt. Lb. per Gross	Teeth per In.
10	1/2	.025	4 3/4	18
12	1/2	.025	5 3/4	18

\*Specify length on order.

**NO. 22 CURVED PRUNER**



Silver steel with teeth on concave edge only. Blade has smooth back. Rip teeth cut on the full, filed and set. Extra large roomy grip beech handle, fully lacquered and polished. 3 nickered screws.

Packed 1/3 dozen in a box.

Length Inches	Stock No.	Points per In.	Width Point In.	Width Butt In.	Wt. Lb. per Doz.
18	(894741)	6	1 1/8	3 3/8	13
22	(894742)	6	1 1/8	3 3/8	16
24	(894743)	6	1 1/8	3 3/8	18

**NO. 10 ATKINS PISTOL GRIP HACKSAW FRAMES**



Hard rubber handle; hung low, directing entire force of stroke on a line with the cutting edge of blade. Frame of cold rolled steel, 3/16-inch thick and 11/16-inch wide. Nickered and highly polished; adjustable, 8 to 12-inch blades; will cut at 4 different angles. Depth under back to cutting edge of blade, 3 inches.

Packed 1 in box with 10-inch blade.

Weight per dozen, 24 pounds. Stock No. (892239)

**NO. 11 ATKINS PISTOL GRIP HACKSAW FRAMES**



Has a hard rubber, open grip handle which gives the operator complete control of the saw at all times. Frame is made of extra high grade steel, 11/16 inch wide and 3/16 inch thick. Adjustable from 8 to 12 inches, also to 4 different angles. Depth under back of cutting edge, 3 inches. Nickered and polished finish.

Packed 1 in box with 10-inch blade.

Weight per dozen, 20 pounds. Stock. No. (892240)

**NO. 24 CABLE SAWS**



Blade is 12 inches long of Atkins high-grade special steel. Beech handle.

One edge toothed 10 points to the inch; other edge, 13 points. Packed 4 in a box.

Weight per dozen, 9 pounds. Stock No. (892245)

## PLAIN DIGGING BARS



Double beveled cutting blade at one end. Ends painted blue.

Cat. No.	Stock No.	Type	Diam. In.	Lgth. Ft.	Wt. Lb.
413	(892253)	Round	1 1/8	8	28
414	(892254)	Octagon	1 1/8	8	30

## OCTAGON CROW AND DIGGING BARS



Double beveled cutting blade at one end; pointed at other end. Ends painted blue.

Cat. No.	Stock No.	Diam. In.	Lgth. Ft.	Wt. Lb.
401	(892255)	1	7	20
402	(892256)	1	8	25
404	(892257)	1 1/8	7	25
405	(892258)	1 1/8	8	28
406	(892259)	1 1/4	8	33

## OCTAGON TAMPING AND DIGGING BARS



Double beveled cutting blade at one end; fitted with heavy iron tamping shoe. Painted blue.

Cat. No.	Stock No.	Diam. In.	Lgth. Ft.	Wt. Lb.
408	(892260)	1	7	20
409	(892261)	1	8	25
411	(892262)	1 1/8	7	25
412	(892263)	1 1/8	8	30

## ELECTRIC TAMPING BARS



Steel tubing with iron tamping shoes. Painted black.

Cat. No.	Stock No.	Length Feet	Wt. Lb.
416	(892264)	7 1/2	18

## ELECTRIC DIGGING SPUDS WITH TAMPERS



Steel tubing with iron tamping shoe and forged crucible steel blade. This tool is well balanced, and the broad blade makes digging easy. A very superior serviceable tool. Painted black.

Cat. No.	Stock No.	Length Feet	Wt. Lb.
415	(892267)	9	21

## TAMPING BAR OR SLICK HANDLES

Cat. No.	Stock No.	For No. Tamper or Slick	Lgth. Feet	Wt. Lb.
425	(892274)	417	7	7
426	(892275)	418	8	8
427	(892276)	419	7	6
428	(892277)	420	8	7
429	(892278)	421	7	6
430	(892279)	422	8	7
431	(892280)	423	7	7
432	(892281)	424	8	8

## LIGHT SHOE TAMPING BARS



Selected maple handle 1 3/4 inches in diameter, tapered at lower end, fitted with light steel shoe, 1 3/4 x 1/4 inches securely riveted to handle. Tamping end dipped in creosote to prevent decay, then painted blue. Handles smoothly sand finished.

Cat. No.	Stock No.	Length Feet	Wt. Lb.
417	(892268)	7	10
418	(892269)	8	11

## HEAVY SHOE TAMPING BARS



Select maple handle 1 5/8 inches in diameter, tapered at lower end. Fitted with heavy steel shoe 5/8 x 1 1/4 inches. Securely riveted to handle. Tamping end dipped in creosote to prevent decay, then painted blue. Handles smoothly sand finished.

Cat. No.	Stock No.	Length Feet	Wt. Lb.
419	(892270)	7	11
420	(892271)	8	12

## A. T. & T. PATTERN TAMPING BARS



Select maple handle 1 5/8 inches in diameter, tapered at lower end; fitted with extra heavy one-piece shoe, made of 5/8 x 1 1/4-inch side straps; bottom, 1 1/4-inch square steel. Rivets passing through the handle and shoe with heads countersunk, hold the shoe firmly in place. An extremely high grade tamper.

Tamping end dipped in creosote to prevent decay, then painted blue. Handle smoothly sand finished.

Cat. No.	Stock No.	Length Feet	Wt. Lb.
421	(892272)	7	12
422	(892273)	8	13

## PROFESSIONAL DIGGER



The Professional was designed and perfected to meet the need of a better and more powerful digger for all types of soil.

A strong, chisel type, heat-treated blade securely bolted to a strong, round design, straight handle loosens the soil. The heat-treated bucket blade operated by a lever scoops up a full load.

Attractive red enamel protects metal parts.

Cat. No.	Stock No.	Hole Size	Length Overall	Weight Each
1	(894810)	34"	4' 10"	16 Lbs.
2	(894811)	46"	5' 10"	18 Lbs.

**PERFECTION POST HOLE DIGGERS**

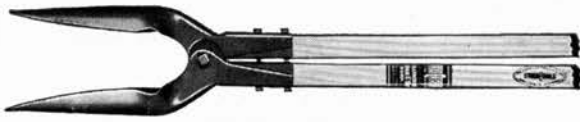

**Regular Pattern**

Blade is 13 gage, 13½ inches long and 7 inches wide; painted orange and black. Ash handles, lacquer finish.

Catalog No.	Stock No.	Length Handle Ft.	Wt. Lb.
439	(892282)	4	10
440	(892283)	7	12
441	(892284)	8	13

**Perfection Digger Handles**

Catalog No.	Stock No.	Length Handle Ft.	Wt. Lb.
444	(892285)	4	2½
445	(892286)	7	3¼
446	(892287)	8	3½

**EVERSTICK STANDARD  
EARTH AUGERS**

**Less Handle**

Adapted for use with Blackburn's telescope handle.

Cat. No.	Stock No.	Diam. Hole Inches	Weight Pounds
8	(892292)	8 to 14	28½
5	(892293)	5 to 8	28½



**CHANCE TELESCOPIC TRIP AUGER**

An efficient, economical tool for boring holes for poles, guy anchors, etc. Every twist of the handle pulls the blades into the ground like a carpenter's auger.

The separate extension blade on the No. 812 auger is adjustable to diameters from 8 to 12¾ inches, so that it is possible to bore seven different size holes to a depth of 8 feet with the same auger.

**Telescoping Augers**

Depth of Hole, 5' to 8'.

Cat. No.	Stock No.	Dia. of Hole	Wt. Each
610	(892294)	6½" to 8½"	26
812	(892295)	8" to 12¾"	28

**Handles for Telescoping Augers**

Description—Auger Handle Assembled	Stock No.	Wt. Each
177	(892298)	10 lbs.



**IWAN AUGER BLADES**

**Less Handle**

Adapted for use with Blackburn's telescope handle.

Cat. No.	Stock No.	Diam. Hole Inches	Weight Pounds
5	(892299)	5	4
6	(892300)	6	6
7	(892301)	7	7
8	(892302)	7	7
10	(892303)	10	8
12	(892304)	12	14



**CHANCE EXPANDING AND TAMPING BAR**



Wherever expanding anchors are used, the Chance Expanding and Tamping Bar should be used also because it simplifies the expanding job. The hook wraps around the anchor rod. This keeps the tamp from slipping off the anchor top plate and consequently makes expanding easier and quicker.

The base is a "Duramel" casting attached to the hard maple handle by two heavy strips of steel.

Cat. No.	Stock No.	Length	Approx. Wt. Each
10	(892307)	10'	24
10-H	(892308)	10' Heavy	27
12	(892309)	12'	28
12-H	(892310)	12' Heavy	33½

**SHOVELS—STRAIGHT WOOD HANDLES**



**Plain Black—Strap Pattern**

**Hickory or Ash**

Strap 22 inches; Blade 9 x 12 inches.

Cat. No.	Stock No.	Handle Ft.	Wt. Lb.
16	(892312)	7	8
17	(892313)	8	9
18	(892314)	9	10
19	(892315)	10	11

**Maple**

Strap 22 inches; Blade 9 x 12 inches.

Cat. No.	Stock No.	Handle Ft.	Wt. Lb.
43	(892318)	7	8
44	(892319)	8	9
44A	(892320)	9	10
44B	(892321)	10	11

**JOSLYN SHOVEL HANDLES**

**Strap Pattern**

**Hickory and Ash**

Cat. No.	Stock No.	Length Feet	Wt. Lb.
27	(892322)	6	3
28	(892323)	7	4
29	(892324)	8	5
30	(892325)	9	6
31	(892326)	10	7
32	(892327)	12	8

**Maple**

Cat. No.	Stock No.	Length Feet	Wt. Lb.
74	(892328)	7	4
74A	(892329)	8	5
74B	(892330)	9	6
74F	(892331)	10	7

## SQUARE POINT SHOVELS



One-piece, solid shank, socket pattern. Sturd-E heavy duty, flexsteel quality, heat treated, 15-gauge blades, X grade handles, sanded and waxed. Black finish blades. Blade 9 3/4 x 12 inches.

Cat. No.	Stock No.	Size No.	Description	Handle In.	Wt. Lb.
806	(892332)	2	D Handle	27	5 1/2
809	(892333)	2	Long Handle	51	5 1/2

## ROUND POINT SHOVELS

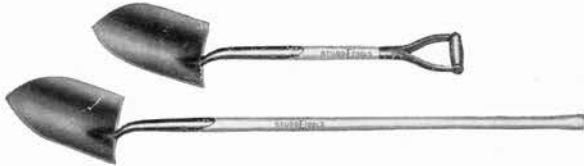

Plain back, strap pattern. Flexsteel quality, heat treated, A grade, 14-gauge blade, XX grade handles, sanded and waxed. Black finish blades. Blade 9 x 12 inches.

Cat. No.	Stock No.	Size No.	Description	Handle In.	Wt. Lb.
842	(892334)	2	D Handle	26	4 1/2
843	(892335)	2	Long Handle	51	4 1/2

## LONG SHOVEL HANDLES



Finest selected white ash, wax finished. Heavy double bend, for round and square point shovels.

Cat. No.	Stock No.	Lgth. Ft.	Grade	Wt. Lb.
82	(892336)	4 1/2	XX	2
83	(892337)	4 1/2	X	2
84	(892338)	4 1/2	No. 1	2

## PEAVIES

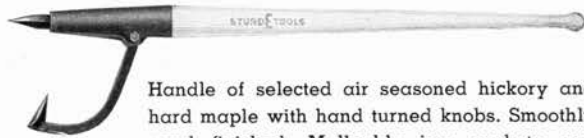

Handle of selected air seasoned hickory and hard maple with hand turned knobs. Smoothly sand finished. Malleable iron sockets and crucible steel hooks with duck bill points. Pikes are of crucible steel and driven in. Metal parts painted blue. Diameter handle, 2 1/2 inches.

### Hickory

Cat. No.	Stock No.	Handle Ft.	Wt. Lb.
124	(892369)	4	8
125	(892370)	4 1/2	9
126	(892371)	5	10

### Maple

Cat. No.	Stock No.	Handle Ft.	Wt. Lb.
127	(892372)	4	8
128	(892373)	4 1/2	9
129	(892374)	5	10

## SPOONS

Plain back, strap pattern. Flexsteel quality, heat treated, 13-gauge blade. XX grade handles, sanded and waxed. Black finish blades.

### Eastern Pattern



### Hickory or Ash Handles

Strap 22 inches; Blade 9 1/2 x 10 1/2 inches.

Cat. No.	Stock No.	Handle Ft.	Wt. Lb.
A55	(892339)	6	7
55	(892340)	7	8
56	(892341)	8	9
57	(892342)	9	10
58	(892343)	10	11
58A	(892344)	12	13

### Maple Handles

Strap 22 inches; Blade 9 1/2 x 10 1/2 inches.

Cat. No.	Stock No.	Handle Ft.	Wt. Lb.
64A	(892345)	7	8
64B	(892346)	8	9
64C	(892347)	9	10
64D	(892348)	10	11

### Western Pattern



### Hickory or Ash Handles

Strap, 22 inches; Blade 8 1/2 x 9 3/4 inches.

Cat. No.	Stock No.	Handle Ft.	Wt. Lb.
49	(892349)	6	7
50	(892350)	7	8
51	(892351)	8	9
52	(892352)	9	10
53	(892353)	10	11
54	(892354)	12	13

### Maple Handles

Strap, 22 inches; Blade 8 1/2 x 9 3/4 inches.

Cat. No.	Stock No.	Handle Ft.	Wt. Lb.
62	(892355)	7	8
63	(892356)	8	9
64	(892357)	9	10
64A	(892358)	10	11

## SPOON HANDLES

### Hickory or Ash

Cat. No.	Stock No.	Length Feet	Wt. Lb.
65	(892359)	6	4
66	(892360)	7	5
67	(892361)	8	6
68	(892362)	9	7
69	(892363)	10	8
70	(892364)	12	9

### Maple

Cat. No.	Stock No.	Length Feet	Wt. Lb.
71	(892365)	7	5
72	(892366)	8	6
73	(892367)	9	7
73A	(892368)	10	8

**CARRYING OR LUG HOOKS**



Handles of selected air seasoned hickory and hard maple with hand turned knobs, smoothly sand finished.

Hooks are crucible steel, hung in heavy malleable iron clasp and swivel. Metal parts painted blue.

**Standard Pattern Hickory**

Diameter handle, 2 1/2 inches.

Cat. No.	Stock No.	Handle Ft.	Wt. Lb.
103	(892375)	4	7
104	(892376)	4 1/2	8
105	(892377)	5	9

**Standard Pattern Maple**

Diameter handle, 2 1/2 inches.

Cat. No.	Stock No.	Handle Ft.	Wt. Lb.
100	(892378)	4	7
101	(892379)	4 1/2	8
102	(892380)	5	9

**W.U. Pattern Hickory**

Diameter handle, 3 inches.

Cat. No.	Stock No.	Handle Ft.	Wt. Lb.
112	(892381)	5	12
113	(892382)	6	14
114	(892383)	7	16



**CANT HOOKS**

Handles of selected air seasoned hickory and hard maple with hand turned knobs. Smooth sand finished.

Hooks are crucible steel with duck bill points, hung in heavy malleable iron clasp.

Toe rings are malleable iron.

Metal parts painted blue.

Diameter handle 2 1/2 inches.

**Hickory**

Cat. No.	Stock No.	Handle Ft.	Wt. Lb.
118	(892393)	4	7 1/2
119	(892394)	4 1/2	8
120	(892395)	5	8 1/2

**Maple**

Cat. No.	Stock No.	Handle Ft.	Wt. Lb.
121	(892396)	4	7 1/2
122	(892397)	4 1/2	8
123	(892398)	5	8 1/2

**CANT HOOK AND PEAVEY HANDLES**

Diameter handle, 2 1/2 inches.

**Hickory**

Cat. No.	Stock No.	Handle Ft.	Wt. Lb.
130	(892399)	4	3 1/2
131	(892400)	4 1/2	4
132	(892401)	5	4 1/2

**Maple**

Cat. No.	Stock No.	Handle Ft.	Wt. Lb.
133	(892402)	4	3 1/2
134	(892403)	4 1/2	4
135	(892404)	5	4 1/2

**CARRYING OR LUG HOOK HANDLES**

**Standard Pattern**

Diameter handle, 2 1/2 inches.

**Hickory**

Cat. No.	Stock No.	Handle Ft.	Wt. Lb.
109	(892384)	4	3
110	(892385)	4 1/2	4
111	(892386)	5	5

**Maple**

Cat. No.	Stock No.	Handle Ft.	Wt. Lb.
106	(892387)	4	3
107	(892388)	4 1/2	4
108	(892389)	5	5

**W. U. Pattern**

Diameter handle, 3 inches.

**Hickory**

Cat. No.	Stock No.	Handle Ft.	Wt. Lb.
115	(892390)	5	6
116	(892391)	6	8
117	(892392)	7	10

**CHANCE SAFETY REVERSIBLE POINT PIKE POLE**



A new safety innovation is the Chance Pike Pole with removable point. The point is made in a separate piece, flat on one end with a gimlet point on the other. A spring catch on the side of the point holds it in place when slipped into the end of the ferrule on the pole.

Made of Douglas or Western Fir, free from all defects, and lacquer finished. The ferrule is made of high grade malleable iron. Removable pike point is made of steel, heat treated. Ferrule and pike may be purchased separately.

Cat. No.	Stock No.	Dia. and Length	Wt. Each
210P	(892431)	2" x 10'	8 lbs.
212P	(892432)	2" x 12'	9 lbs.
214P	(892433)	2" x 14'	11 lbs.
216P	(892434)	2" x 16'	13 lbs.
218P	(892435)	2" x 18'	15 lbs.
220P	(892436)	2" x 20'	17 lbs.

**FIR PIKE POLES**



**Fitted With Tubular Guards**

Guard will fit poles equipped with special ferrules only. Handles are lacquer finish.

Catalog No.	Stock No.	Diam. In.	Lgth. Ft.	Wt. Lb.
205G	(892439)	2	12	10
206G	(892440)	2	14	12
207G	(892441)	2	16	14
208G	(892442)	2	18	16
209G	(892443)	2	20	18
219G	(892444)	2 1/2	12	13
220G	(892445)	2 1/2	14	15
221G	(892446)	2 1/2	16	17
222G	(892447)	2 1/2	18	19
223G	(892448)	2 1/2	20	21

## NO. G TUBULAR PIKE POLE GUARDS



Tubular guard, not attached

Cat. No.	Stock No.	Lgth. In.	Wt. Lb.
<b>G</b>	<b>(892449)</b>	<b>6%</b>	<b>1</b>

## PIKE POLES

These poles are made of selected Douglas or Western fir, free from all defects. This timber is especially adapted to pike poles. Has the strength of ash, yet is light in weight.

Pikes are of  $1\frac{3}{16}$ -inch round crucible steel of the collar pike design with sharp points. They are set in creosote.

Ferrules are made of steel tubing, riveted securely and rivets go through the ferrule and pike, holding the pike firmly in the pole.

All poles are smoothly sand finished. Metal parts painted blue.

### Light Pattern



These poles are 2 inches in diameter, not tapered.

Cat. No.	Stock No.	Length Feet	Wt. Lb.
<b>205</b>	<b>(892405)</b>	<b>12</b>	<b>9</b>
<b>206</b>	<b>(892406)</b>	<b>14</b>	<b>11</b>
<b>207</b>	<b>(892407)</b>	<b>16</b>	<b>13</b>
<b>208</b>	<b>(892408)</b>	<b>18</b>	<b>15</b>
<b>209</b>	<b>(892409)</b>	<b>20</b>	<b>17</b>



### A. T. & T. Pattern

Diameter at center,  $2\frac{1}{2}$  inches, tapering to 2 inches at ends. This gives extra strength at center where needed with very little increase in weight.

Cat. No.	Stock No.	Length Feet	Wt. Lb.
<b>219</b>	<b>(892410)</b>	<b>12</b>	<b>12</b>
<b>220</b>	<b>(892411)</b>	<b>14</b>	<b>14</b>
<b>221</b>	<b>(892412)</b>	<b>16</b>	<b>16</b>
<b>222</b>	<b>(892413)</b>	<b>18</b>	<b>18</b>
<b>223</b>	<b>(892414)</b>	<b>20</b>	<b>20</b>

## RAISING FORKS, GUARDED PIKE POLES



Made of selected Douglas or Western fir with malleable iron ferrule and fork in one piece, driven onto pole and secured by a rivet.

Handles are furnished in two sizes, the 2-inch are parallel and the  $2\frac{1}{2}$ -inch are tapered to 2 inches at the ends.

Metal parts painted blue.

Cat. No.	Stock No.	Length Feet	Diam. In.
<b>226</b>	<b>(892415)</b>	<b>10</b>	<b>2</b>
<b>227</b>	<b>(892416)</b>	<b>12</b>	<b>2</b>
<b>228</b>	<b>(892417)</b>	<b>14</b>	<b>2</b>
<b>229</b>	<b>(892418)</b>	<b>16</b>	<b><math>2\frac{1}{2}</math></b>
<b>230</b>	<b>(892419)</b>	<b>18</b>	<b><math>2\frac{1}{2}</math></b>
<b>231</b>	<b>(892420)</b>	<b>20</b>	<b><math>2\frac{1}{2}</math></b>

## MULE SUPPORTS

Made of 4-inch selected hardwood.

Octagon shape, reinforced with strong steel bands at each end.

Heavy crucible steel fork and spikes.

Wood painted blue, metal black.

Cat. No.	Stock No.	Length Feet	Wt. Lb.
<b>303A</b>	<b>(892450)</b>	<b>6</b>	<b>38</b>
<b>304</b>	<b>(892451)</b>	<b>7</b>	<b>42</b>
<b>305</b>	<b>(892452)</b>	<b>8</b>	<b>46</b>

## PIKE POLE OR RAISING FORK HANDLES



Made of selected Douglas or Western fir. Smoothly sand finished.

Cat. No.	Stock No.	Diam. In.	Lgth. Ft.	Wt. Lb.
<b>241</b>	<b>(892421)</b>	<b>2</b>	<b>12</b>	<b>8</b>
<b>242</b>	<b>(892422)</b>	<b>2</b>	<b>14</b>	<b>10</b>
<b>243</b>	<b>(892423)</b>	<b>2</b>	<b>16</b>	<b>12</b>
<b>244</b>	<b>(892424)</b>	<b>2</b>	<b>18</b>	<b>14</b>
<b>245</b>	<b>(892425)</b>	<b>2</b>	<b>20</b>	<b>16</b>
<b>248</b>	<b>(892426)</b>	<b><math>2\frac{1}{2}</math></b>	<b>12</b>	<b>11</b>
<b>249</b>	<b>(892427)</b>	<b><math>2\frac{1}{2}</math></b>	<b>14</b>	<b>13</b>
<b>250</b>	<b>(892428)</b>	<b><math>2\frac{1}{2}</math></b>	<b>16</b>	<b>15</b>
<b>251</b>	<b>(892429)</b>	<b><math>2\frac{1}{2}</math></b>	<b>18</b>	<b>17</b>
<b>252</b>	<b>(892430)</b>	<b><math>2\frac{1}{2}</math></b>	<b>20</b>	<b>19</b>

## STANDARD DEADMEN



Made of 2 x 4-inch white oak with wrought steel fork and spike; fitted with steel bands at each end to prevent splitting.

Fork is securely fastened by rivet through the band.

This support is adapted to the heaviest kind of work.

Wood varnished, metal painted black.

Cat. No.	Stock No.	Length Feet	Wt. Lb.
<b>306</b>	<b>(892456)</b>	<b>8</b>	<b>30</b>

## JENNY SUPPORTS

Made very strong for raising wooden poles.

The best selected hardwood is used in this support.

The fork is of crucible steel; heavy braces and bolts make it very serviceable.

Spikes are bolted to each leg to avoid slipping.

Shipped knocked down.

Cat. No.	Stock No.	Lgth. Ft.	Wt. Lb.
<b>301</b>	<b>(892453)</b>	<b>6</b>	<b>25</b>
<b>302</b>	<b>(892454)</b>	<b>7</b>	<b>30</b>
<b>303</b>	<b>(892455)</b>	<b>8</b>	<b>35</b>



**NO. 5197 PAY-OUT AND TAKE-UP REELS**

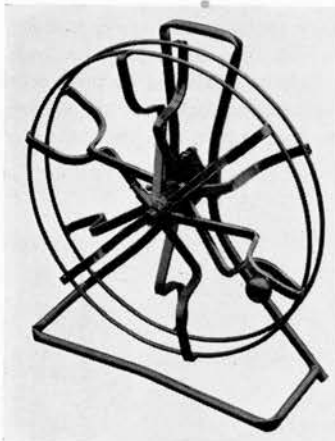

Designed to pay out drop wire, and also to take up wire. It is demountable and can be used in a vertical or horizontal plane when removed from the vehicle.

The outer spider is removable and adjustable with a plunger type lock. This permits the placing of coils as well as the removal of same from the reel.

A variable tension brake controls the paying out speed of the wire.

Made of malleable castings, and high grade steel. It will take a coil of wire

having an inside diameter of 15 inches.

Cat. No.	Stock No.	Inside Coil Diam. In.	Wt. Lb.
5197	(892461)	15	32

**MATTHEWS ADJUSTABLE REELS**  
Pay-Out and Take-Up

A ruggedly constructed reel for paying out or taking up wire. The frame is durable white oak, and the heavy gage steel turntable can be easily grounded which is an important safety feature.



In taking down old wire, it can be re-coiled perfectly.

The five arms for holding the coil of wire can be uniformly contracted or expanded to snugly fit the inside of coils of any diameter from 14 inches minimum to 21 inches maximum. Can be locked in any position by means of the hand lock nut.

Overall length of frame, 48 inches; width 24 inches. Diameter of turntable, 34 inches. Diameter, arms opened, 21 inches; arms closed, 14 inches. Height of arms, 9 inches.

Unless otherwise specified, the reel is furnished with brake which keeps the turntable from racing when paying out wire and prevents the possibility of getting too much slack. The brake is not necessary if the reel is to be used only for taking up wire.

Cat. No.	Stock No.	Description	Wt. Lbs.
7	(892462)	Reel with Brake	100
11	(892463)	Reel without Brake	90

**NO. 520 BARROW REELS**

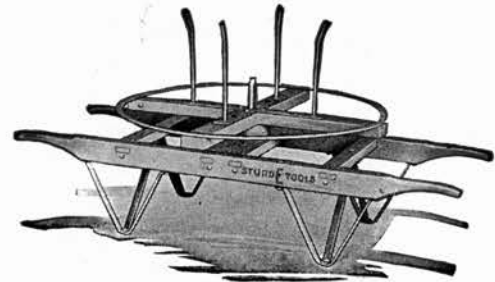

This reel is made of hardwood and is of very strong construction to stand heavy work.

Metal strips brace and reinforce the reel throughout.

Steel sleeve on the reel fits our solid steel center pin on barrow. Large metal discs on the reel and barrow form a common bearing surface around the pin.

A very satisfactory reel for telephone and electric light work. Pins are adjustable for 12, 18, 21 and 24-inch coil.

Wood painted delft blue, metal parts black.

Cat. No.	Stock No.	Wt. Lb.
520	(892457)	80

**No. 521 Extra Guard Pin**

Cat. No.	Stock No.	Wt. Lb.
521	(892458)	1½

**JOSLYN NO. 501 FOLDING TAKE-UP REELS**

This reel is the collapsible type and is composed of two parts, the wooden stand and the metal reel.

Stand is of hardwood, mortised and tenoned. Steel reinforcements make the stand very rigid and strong.

Reel is malleable iron and steel. For use in taking down and coiling wire. When reel is filled and coil of wire removed, the reel is readily folded. Both stand and reel collapse.

Stand painted delft blue, reel and metal parts black.



Cat. No.	Stock No.	Size Coil In.	Wt. Lb.
501	(892459)	21	42

**NO. 510 PAY-OUT REELS**

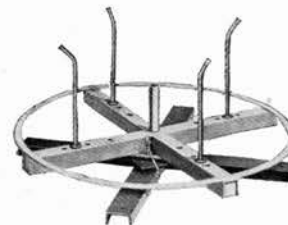

This reel is of hardwood, reinforced and braced throughout with metal strips.

Pins are adjustable for 12, 18, 21 and 24-inch coils.

Wood painted delft blue, metal parts black.

Cat. No.	Stock No.	Wt. Lb.
510	(892460)	40

## FSA WIRE REEL WITH METER

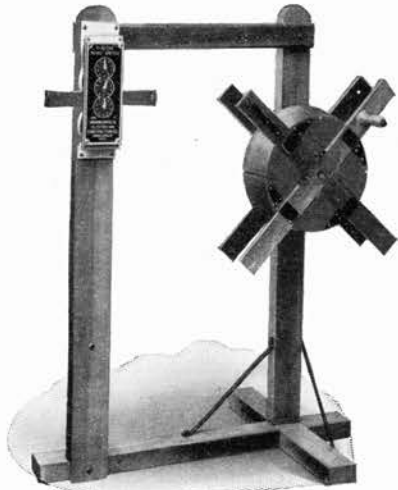

A machine for measuring the various sizes of Wire, Cordage, etc. It will save time and money and in a short time will demonstrate its great value.

In the meter the wire passes between two self-adjusting rollers which admit of wide range, and will measure accurately large or small sizes. The pointers are movable and readily adjusted to zero point. Takes up to  $\frac{3}{4}$  in.

The Reel is provided with removable cross bars, and the drum with grooves so the coil can be bound with tie wires and removed in compact form. The meter shows the number of feet in the coil and does away with measuring on the floor.

The Reel and Meter, being movable and occupying small space, can be placed where convenient for measuring and set aside when not in use.

Capacity of reel, 1,000 ft. of No. 14 B. and S. gauge. Other sizes in proportion. Stock No. (894772)

## DUO-SAFETY LADDER SHOES

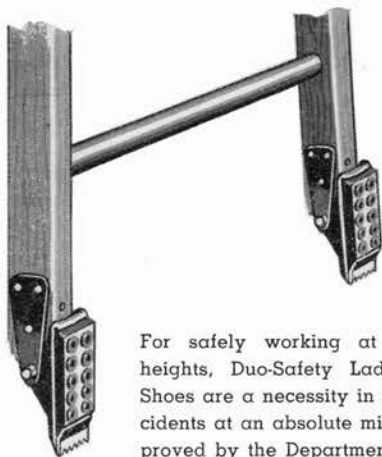

For safely working at dangerous heights, Duo-Safety Ladder Safety Shoes are a necessity in keeping accidents at an absolute minimum. Approved by the Departments of Labor and State Industrial Commissions, these rugged safety shoes can be instantly converted from rubber soled shoes for inside use, to rugged spiked toes for use on the ground. Suction holes have 10 inches of gripping area. Spiked toes are made of hardened steel. Duo-Safety Shoes will fit any standard ladder rail.

Stock No. (894838)

## DUO-SAFETY EXTENSION LADDERS

### Type D

A really great ladder is Duo-Safety's Type "D", suitable for all the straight or extension ladder requirements of heavy industry. Type D is built in accordance with approved safety standards, has rungs of second growth hickory reinforced by steel rods, and equipped with special automatic locks and Duo-Safety ladder's famous Safety Shoes. Available in one, two and three section ladders.

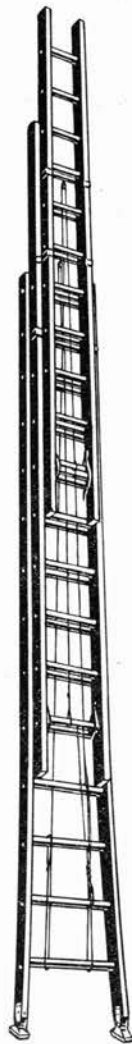

Type D

### One Section

Cat. No.	Stock No.	Size
10-D1	(894683)	10'
12-D1	(894684)	12'
14-D1	(894685)	14'
16-D1	(894686)	16'
18-D1	(894687)	18'
20-D1	(894688)	20'
22-D1	(894689)	22'

### Two Section

Cat. No.	Stock No.	Size
16-D2	(894690)	16'
18-D2	(894691)	18'
20-D2	(894692)	20'
22-D2	(894693)	22'
24-D2	(894694)	24'
26-D2	(894695)	26'
28-D2	(894696)	28'
30-D2	(894697)	30'

NOTE: Larger Sizes available on request.

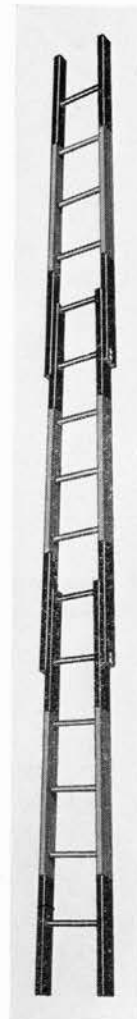

Type E

### Type E

Designed primarily for Telephone and Telegraph Companies, Type "E" is a sectional ladder which can be easily stored in a small space in Utility trucks. Sketch shows the steel reinforcing of the dovetail pronged section ends. Type "E" is an exceptionally useful and versatile ladder, built to withstand the most severe usage. Available in either special or natural finishes.

Type E Stock No. (894698)

**KLEIN'S SIDE CUTTING PLIERS**



Diamond special for use on bare and insulated wire.

Cat. No.	Stock No.	Size Inches	Wt. Lb. per Doz.
201-6	(892466)	6	5 1/4
201-7	(892467)	7	7 1/4
201-8	(892468)	8	11 3/4
201-9	(892469)	9	14

**ROUND NOSE N. E. TYPE**



Nose and all edges rounded and shoulder of head removed.

Cat. No.	Stock No.	Size Inches	Wt. Lb. per Doz.
201-6NE	(892470)	6	5
201-7NE	(892471)	7	7 1/2
201-8NE	(892472)	8	12
201-9NE	(892473)	9	12 1/2

**WITH SLEEVE JOINT TWISTER**



Diamond special for use on bare and insulated wire, with sleeve joint twister.

Cat. No.	Stock No.	Size Inches	Wt. Lb. per Doz.
212-6NE	(892474)	6	5 1/4
212-7NE	(892475)	7	7 1/4
212-8NE	(892476)	8	11 3/4

**NO. 245-5 OBLIQUE CUTTING PLIERS**



**Lap Joint Type**

For electricians, telephone men and switchboard builders. Size, 5 inches. Weight per dozen, 3 pounds. Stock No. (892477)

**NO. 245-5W WITH W STRIPPING NOTCHES**

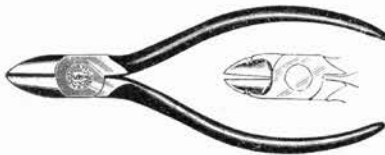

For removing acetate cellulose insulation from .050 and .058 wires used on telephone distributing frames, etc.

Size, 5 inches. Weight per dozen, 3 pounds. Stock No. (892478)

**NOS. 202-5 AND 202-6**



Cuts close, the narrow head permitting its use in confined places. Knives are perfectly fitted.

Cat. No.	Stock No.	Size Inches	Wt. Lb. per Doz.
202-5	(892479)	5	3 3/4
202-6	(892480)	6	4

**WITH W STRIPPING NOTCHES, SLEEVE OPENINGS AND SKINNING HOLE**

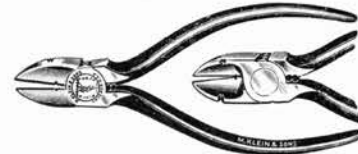

**NO. 202-5-SW**

An all-purpose cutting tool for telephone installation and maintenance work. The W notches will slit acetate cellulose and other insulations from wires up to .058 o.d. A stripping hole .052 diameter is provided in blades. Sleeve openings in handles.

Size, 5 1/2 inches. Weight, per dozen, 3 3/4 pounds.

Stock No. (892481)

**NO. 240-5**



Has notch for stripping small wires placed 3/16 inch from hinge and has diameter of .052 inch.

Cat. No.	Stock No.	Size Inches	Wt. Lb. per Doz.
240-5	(892482)	5	4
240-6	(892483)	6	4 1/4

**NO. 242-6**

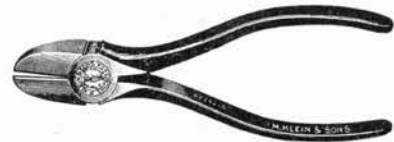

Heavy pattern. For use where it is not necessary to reach into confined places.

Size, 6 inches. Weight per dozen, 4 1/4 pounds.

Stock No. (892486)

## LONG NOSE PLIERS



### Without Cutters

Adapted for stripping the ends of insulated wire and for work in confined spaces.

Cat. No.	Stock No.	Size Inches	Wt. Lb. per Doz.
301-5	(892487)	5	3¼
301-6	(892488)	6	3¾
301-7	(892489)	7	4¼

## LONG NOSE PLIERS



### Side Cutting

Designed for work in restricted spaces. Equipped with cutting knives.

Cat. No.	Stock No.	Size Inches	Wt. Lb. per Doz.
203-5	(892490)	5	3¼
203-6	(892491)	6	3¾
203-7	(892492)	7	4¼

## NO. 316-S LONG NOSE SLEEVE PLIERS



### Bell System Type

Jaws are 2 inches long with 1/16-inch point. Has openings for No. 17 B. & S. double tube copper sleeves. Handles 4 inches long, temper blued; polished head and jaws.

Size, 6 inches. Weight per dozen. 3¾ pounds. Stock No. (892493)

## NO. 303-6 LONG NEEDLE NOSE PLIERS



Long nose permits use in confined spaces. Has polished head and handles temper blued.

Size, 6 inches. Weight per dozen, 3 pounds. Stock No. (892494)

## NO. 302-6 KLEIN'S LONG CURVED NOSE PLIERS

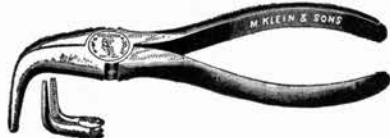

Angle is arranged to give full clearance and prevent skinning of knuckles.

Size, 6 inches. Weight per doz., 3¼ pounds. Stock No. (892495)

## NO. 305-6 LONG FLAT NOSE PLIERS



Has long wide flat nose. Inside of jaws left smooth if desired. Has polished head and handles temper blued.

Size, 6 inches. Weight per doz., 3½ pounds. Stock No. (892496)

## NO. 206-6 LONG FLAT NOSE PLIERS



### Side Cutting

Has long wide flat nose and cutting knives. Smooth jaws if desired. Has polished head and handles temper blued.

Size, 6 inches. Weight per doz., 3½ pounds. Stock No. (892497)

## NO. 311-5½ LONG FLAT NOSE PLIERS



### Spring Adjuster

Hollow ground on outside of jaws to reach between and grasp springs easily.

Size, 5½ inches. Weight per dozen, 3¼ pounds. Stock No. (892498)

## NO. 313-6 HEAT-COIL PLIERS



For removing heat coils from switchboards and telephone terminals, the points of the nose being shaped to fit the coils. Also used for removing battery caps as well as holding any cylindrical object.

Size, 6 inches. Weight per doz., 3¾ pounds. Stock No. (892499)

## NO. 304-6 LONG DUCK BILL PLIERS



For general use. Jaws are wider and heavier than those of flat nose pliers. Has polished head and handles temper blued.

Size, 6 inches. Weight per doz., 3¼ pounds. Stock No. (892501)

**NO. 205-6 LONG DUCK BILL PLIERS**



**Side Cutting**

For general use. Jaws are wider and heavier than those of flat nose pliers. Has polished head and handles temper blued.

Size, 6 inches. Weight per dozen, 3 pounds. Stock No. (892502)

**NO. 105-17 SPLICING CLAMPS**



Large hole can be used for guy wire or messenger strand.

Copper wire Nos. 2, 4, 6, 8, 10 and 12 A.W.G.

Iron wire Nos. 4, 6, 8, 10 and 12 B.W.G.

Size, 10 3/4 inches. Weight per dozen, 15 pounds.

Stock No. (892505)

**NO. 102-3 SPLICING CLAMPS**



Has five sets of chambers for twisting double tube sleeves.

For copper sleeves Nos. 6, 8, 10, 12, 14, 17, A.W.G.

For iron sleeves Nos. 8, 10, 12, 14, 16, 19, B.W.G.

Size, 10 3/4 inches. Stock No. (892504)

**NO. 132-15 COMBINATION WIRE AND SLEEVE CLAMPS**



The unusual range of wire and sleeve sizes covered by this clamp makes it practically a universal tool for telegraph, telephone and power line work. Has 5 round holes for twisting bare wire and an oval opening for guy wire or messenger strand. Copper wire Nos. 4, 6, 8, 10, 12, A.W.G. Iron wire Nos. 6, 8, 10, 12, 14, B.W.G. Strand opening .437x.624.

Reverse side has 5 chambers for twisting double tube sleeves. Copper sleeves Nos. 6, 8, 10, 12, 14, 17, A.W.G. Iron sleeves Nos. 8, 10, 12, 14, 16, 19, B.W.G.

Hammer forged from high grade crucible tool steel. Oil tempered, polished head and black handles.

Size, 11 1/4 inches. Weight per dozen, 16 pounds.

Stock No. (892507)

**LINEMEN'S WRENCHES**



**Bell System Type**

Forged from selected bar steel and of the open end type with two openings of different sizes at each end. A hole also provided for turning in pole steps, etc.

Cat. No.	Stock No.	For Hardware In.	Wt. Lb. per Doz.
3146	(892508)	5/8	21
3146A	(892509)	3/4	21

**CHANCE LINEMEN'S SOCKET WRENCHES**



For tightening guy clamps. Close position of the bolts does not interfere with its use. Nuts can be tightened without removing the wrench. It fits all standard nuts in pole line construction, and is excellent for driving lags, steps, bolts and back rods. Made of drop-forged steel.

Cat. No.	Stock No.	Nut Size	Wt. Lb.
C-154	(892510)	5/8 and smaller	2 1/2
C-234	(892511)	3/4 and smaller	3 1/4

**NO. 2100-5 XELA ELECTRICIAN'S SCISSORS**

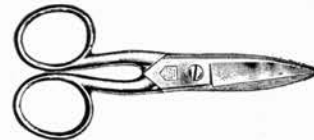

Made of high grade steel properly tempered.

Has screw hinge. Nickel-plated finish.

Size, 5 inches. Weight per dozen, 2 pounds.

Stock No. (892514)

**DIAMOND B BRAID STRIPPER**

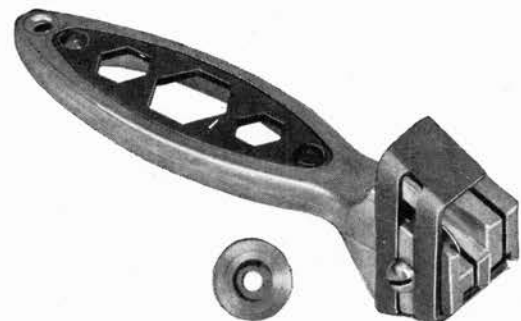

This tool saves considerable time in removing the braided covering from Drop Wires. Also for holding bridging connectors while they are being installed or removed. There are three grooves for accommodating three sizes of drop wire.

Groove	Width	Depth of Cut
A	.270"	.060"
B	.330"	.080"
C	.375"	.110"

Sliding guard protects the thumb, at the same time forcing wire down on cutting blade. Blade can be rotated to new position when used section becomes dull.

Handle provided with steel wrench plate. Hexagonal opening of 3/8", 7/16" and 9/16" for bridging connectors, nuts or heads.

Aluminum die-casting, natural finish. Steel parts oiled. Weight 1/4 lb.

Catalog No. 779 Stock No. (892513)

## CHICAGO GRIPS For Bare Wire

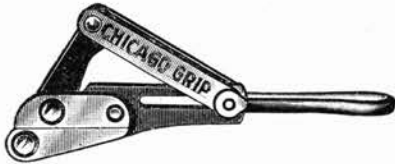

Main body piece and lever are forged steel. Draw parts are wrought steel. Gripping jaws are machined.

Cat. No.	Stock No.	Description	Max. Open Inches	Wt. Lb.
1613-30	(892515)	For No. 6 Wire and Smaller	2187	1½
1613-30B	(892516)	With Bronze Lined Jaws	1875	1½
1613-40	(892517)	For No. 0 Wire and Smaller	3125	2½
1613-40B	(892518)	With Bronze Lined Jaws	3125	2¾
1613-50	(892519)	For No. 0000 Wire and Smaller	50	7½
1613-50B	(892520)	With Bronze Lined Jaws	50	7½

## For Messenger Strand and Heavy Cable



Forged from alloy steel heat treated. Gripping jaws are machined smooth. Rivets are machine turned.

Cat. No.	Stock No.	For Strand	Lbs.	Max. Open In.	Wt. Lb.
1628-5	(892521)	2200 to 10000 Pounds	8000	7/16	5
1628-5B	(892522)	With bronze lined jaws	8000	.375	5
1628-6	(892523)	2200 to 6000 Pounds	8000	13/32	8½
1628-6B	(892524)	With bronze lined jaws	8000	.50	8½
1628-16	(892525)	10000 to 16000 Pounds	15000	11/16	14
1628-16B	(892526)	With bronze lined jaws	15000	.625	14

## HAVEN'S STEEL GRIPS



Almost automatic in action. Handle and eccentric allow instantaneous hold. A shake of the rope on the tackle disengages the grip.

Cat. No.	Stock No.	Description
1604-10	(892527)	For No. 4 Wire and Finer
1604-20	(892528)	For ½-Inch Wire and Finer

## NO. 1700-30 CHICAGO LINEMEN'S TOOLS



Set is combination of Chicago Grip No. 1613-30 with Howes Wire Tool No. 1702-20.

For No. 6 wire and smaller down to No. 13.  
Weight, 4 pounds. Stock No. (892536)

## NO. 1625-20 IMPROVED HAVEN'S GRIPS

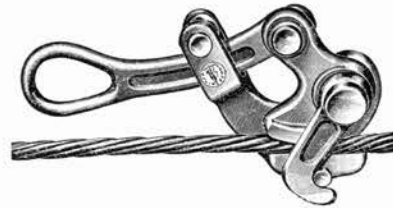

For plain or stranded wire No. 6 to ¾-inch diameter. Made with swing latch which engages stud on lower jaw.

Stock No. (892529)

## BUFFALO GRIPS WITH LOOP OR WITH PULLEY



For gripping wire in the erection of telephone and electric power lines. The Buffalo Grip can be locked open by swinging the loop up. It then can easily be placed on the wire and closed by bringing the loop back to normal position, all with the use of only one hand.



The Buffalo Grip is normally held closed by spring tension, so that after placing the grip on the wire it clings tightly and will not fall off while arranging the tackle for the final pull.

Cat. No.	Stock No.	Extreme Opening, In.	Description
1	(892530) (892532)	.22	Has flat jaws for bare wire from smallest to No. 6 incl. When equipped with pulley, use 5/16" rope.
2	(892531) (892533)	.35	Has flat jaws for bare wire from smallest to No. 0 incl. When equipped with pulley, use 3/8" rope.

## NO. 1702-20 KLEIN'S HOWES WIRE TOOLS



Strap is harness leather 1¼ inches wide and 7 feet long. At one end a forged steel swivel hook is provided with opening to permit anchoring round insulator pin. Forward end has a locking device to hold load at any distance and is so arranged that a wire grip can be readily attached.

Metal parts are galvanized.

Weight per set, 2 pounds. Stock No. (892537)

**NO. 1802-30 KLEIN'S SELF-LOCKING TACKLE BLOCKS**



Especially for use with Klein's Wire Grips. Furnished with 25 feet 3/8-inch "Waterflex" Manila rope, 2 1/2 pounds.

Consists of light steel shell blocks galvanized, fitted with snubbing hook to lock load in any position. To lock load, pull luff rope under hook. To release, simply pull rope. Blocks are arranged with spring guard snap hooks. When pulling up wire to make a splice, it may be used with two grips attached to snaps or with hook to anchor to an insulator pin or other convenient anchorage.. Stock No. (892538)

**KLEIN'S HAND LINES**



Rope is best quality "Waterflex" Manila and does not twist. Spliced to eye of snap hook with galvanized steel thimble.

Snap hook is drop forged and similar to those used on safety straps except that it has round eye.

Cat. No.	Stock No.	Description
1803-60	(892539)	75 Feet of 3/8-Inch Rope
1803-120	(892540)	120 Feet of 3/8-Inch Rope
443A	(892541)	Forged Snap, Eye 1 1/16-Inch I.D.

**MATTHEWS SLACK PULLERS**

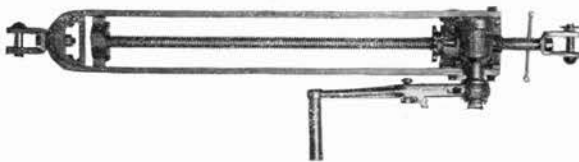

No. 732

Enables one man to do the work of four when taking the slack out of guy strand, messenger wire or changing strain insulators, or for splicing trolley wire, telephone or power cable under tension; also used for pulling back underground cable. Takes the place of block and tackle. One man can easily pull 3000 pounds with the No. 730, 6000 pounds with the Nos. 731 or 732. No slack is lost in dead-ending as strain is held to the exact point pulled.

With the new quick release feature, when the entire take-up has been used, the wire is temporarily dead-ended and the lock released. This permits the slack puller to be immediately extended to its maximum or any intervening length.

Cat. No.	Stock No.	Description	Ship. Wt. Lb.
730	(892544)	Maximum Take-Up, 19 Inches	17
731	(892545)	Same as No. 730, Except That Clevis is Substituted for Hook	17 1/2
732	(892546)	Same as No. 731. Except That it Also Has Quick Take-Up Features	18

The 730 and 731 do not have the quick take-up feature.

**COFFING SAFETY-PULL RATCHET LEVER HOISTS**

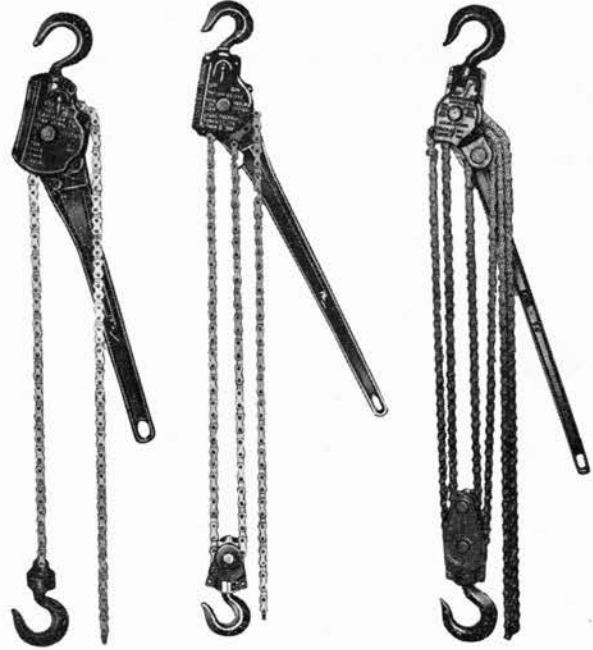

Nos. AG, FG

Nos. ATG, FTG

No. ZG

The Coffing Safety-Pull Ratchet Lever Hoist is built on the ratchet and pawl principle. The load is always locked by sprocket and ratchet pawls (cannot slip or drop load).

Automatic stops prevent handle from spinning in case hand should slip off handle. Reversible handle permits operating hoist in any position.

Safety valve handle, that is, handle will bend before chain will break or hooks will straighten out.

The safety-pull has free chain for quick load adjustment when there is no weight on the hoist.

Special designed hooks of drop-forged, heat-treated alloy steel.

Roller chain to meet Navy specifications, standard on all models.

The frame and lever parts are of certified malleable iron.

Sprockets and ratchets are of alloy steel, heat-treated and ground.

Reversing mechanism, bearing pins, etc., heat-treated alloy steel to meet their specific functions.

Model	Stock No.	Rated Cap. Tons	Net Wt. Lb.	Min. Dist. Hooks In.	Lift Speed per Min. In.	Lb. on Lever Rated Cap.	Std. Lift in In.
*AG	(892550)	3/4	14	13	36	56	56 1/2
*ATG	(892551)	1 1/2	17	15	18	60	57
*FG	(892552)	1 1/2	25	16	48	116	56 1/2
*FTG	(892553)	3	34	17	24	120	57
ZG	(892554)	6	59	25	12	124	53

\*Available with double pawl at extra cost.

The double pawl safety-pull ratchet lever hoists have decided advantages when working in close quarters where a full stroke of the lever is not permitted, because the load can be raised or lowered with a half stroke of the lever.

## MIGHTY MIDGET PULLER



For any pulling job up to 500 lbs. where the requirements are for a compact, light, really portable tool, less than a foot long, and weighing only 6½ lbs., it is especially appreciated by the line-man. The safety-load handle warns when there is an overload; it can be used as a lever or a crank—it locks in either position. Packed in a box 11½" x 4½" x 3¼" Stock No. (894682)

## VAN-WEB NO. 100 HYDRAULIC POLE JACK



It has a raise lift of 60 inches at the hook through the pulley that doubles the lift of the ram.

It is guaranteed to exert a 15,000 lb. pressure on end of ram.

The jack with ram depressed is 41 inches long, and weighs 60 lbs. The pump handle is 25 inches long, and folds down to the side. A handle ring is mounted on the side so weight is balanced for carrying.

No special strength is required to operate the pump handle. The hook lifts ¾ inches on each stroke. A shut-off valve is located at the top of the cylinder and the ram can easily be pushed back in the cylinder when this valve is opened.

The hydraulic pump is operated with No. 10 oil, pushing against the 1½ inch diameter ram. This is sealed in, but can be replaced occasionally for operating efficiency.

The pulley yoke is mounted on a loose piston so the whole yoke can be lifted out and a pike pole set in the cup at the top of the ram, for straightening poles.

This jack is very simple to set up against a pole, requiring only a base laid on the ground for leverage. The hook starts at the bottom of the jack, so one pull will clear most poles.

Stock No. (894840)

## COFFING LOAD BINDERS



For booming poles, logs, pipe, etc.

Drop-forged steel hooks with swivels on both ends. The take-up is ⅝ inch to each stroke of the handle.

If load becomes loose, it can be bound tight simply by drawing on lever. After load is taken off chain, both levers can be tripped at once and chain can be pulled through binder free.

Can also be used as a hoist and for stretching wire or cable.

Model A will boom a load of 3000 pounds. Weight, 11½ pounds. Stock No. (892555)

Model F will boom a load of 6000 pounds. Weight, 24 pounds. Stock No. (892556)

## SIMPLEX PIPE PUSHING AND PULLING JACKS

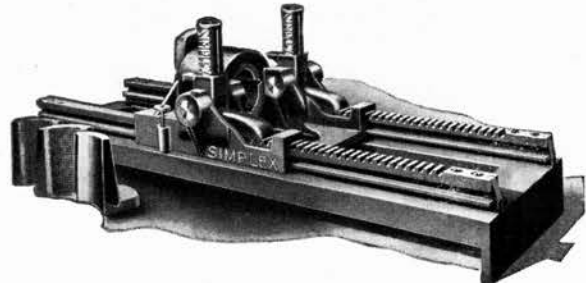

The new Nos. R-332R and R-334R have reversible carriages which eliminate the necessity of reversing the complete pipe pusher to pull pipe.

Properly equipped, No. R-332R will push pipe ¾" to 2" in diameter. No. R-334R will push pipe 2" to 4" in diameter. Specify the size, or sizes, of pipe to be pushed. An adapter, furnished at additional price, enables the No. R-334R to push ¾" to 2" pipe.

Cat. No.	Stock No.	Capacity Tons	Travel	Weight	
				Complete	Jack Only
R-332R	(891061)	15	30"	218 lbs.	150 lbs.
R-334R	(891062)	25	28½"	321 lbs.	208 lbs.

## SIMPLEX AERIAL CABLE AND WIRE TENSIONING JACK

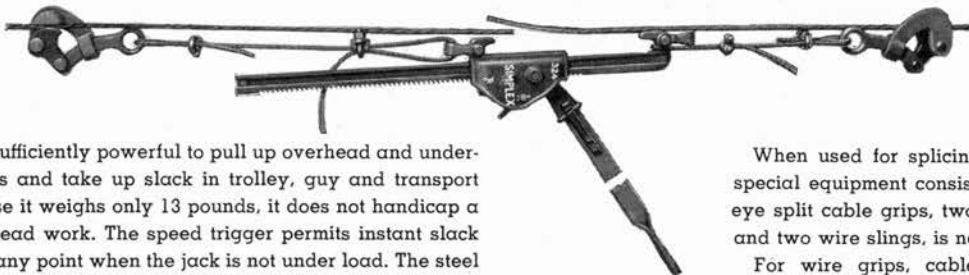

No. 324 is sufficiently powerful to pull up overhead and underground cables and take up slack in trolley, guy and transport wires. Because it weighs only 13 pounds, it does not handicap a man in overhead work. The speed trigger permits instant slack "take up" at any point when the jack is not under load. The steel lever is furnished with a safety spring clip that prevents it from coming out.

The jack is easy to set up because of its non-flexible rack bar and exerts a direct line pull.

For tensioning bare wire use two bare wire grips and two wire slings. See illustration.

When used for splicing overhead cable, special equipment consisting of two double eye split cable grips, two three-bolt clamps and two wire slings, is needed.

For wire grips, cable grips and wire slings, please refer to other sections of this supply catalogue.

Capacity Tons	Travel	Weight
2	20¼"	13 lbs.
Cat. No.	Stock No.	
324	(891026)	

**SIMPLEX POLE PULLING AND POLE STRAIGHTENING JACKS**

For many years Simplex Pole Pulling and Pole Straightening Jacks have been saving man-hours and reducing "out of service" hours for electric power, telephone, telegraph and trolley companies.

**No. 329**

The standard jack of the Bell Telephone Systems and will pull or straighten any pole, large or small. It is single acting, ratchet lowering. The "H" beam sub-base provides a non-slip, firm foundation.



One or two men can pull or straighten poles, pull butts or move loaded poles with no interruption to service and without digging, regardless of the size of the poles, or depth in the ground.

**No. 325**

The Simplex Junior Pole Jack is used for poles up to 30 feet in height. In addition, it is handy as a guy line tightener and for pulling underground cables. The 8' pike pole furnished with the No. 325 is especially handy when it is necessary to straighten poles located beside ditches.

Recommended for rural electrification. It is single acting, ratchet lowering.

**No. 310-A**

Usually thought of as an emergency all-purpose jack. It also pivots on its base, making an excellent pole pulling and straightening jack where the amount of lift is not of primary importance. Compact and husky. It is single acting, ratchet lowering. Lifts on the cap, two positions of the auxiliary shoe, the toe lift, and at any intermediate point by using the chain as a sling. Minimum toe lift height is only 2 1/4". It lifts vertically, and lifts or pushes from any angle. Double lever socket provides for close quarter operation.

Cat. No.	Stock No.	Capacity Tons	Height Inches	Lift Inches	Wt. Lb.
310-A	(891484)	15	22	14	74
325	(891482)	5	50	36	34
329	(891483)	15	37 3/4	22	95

**WOOD PULLEY BLOCKS**

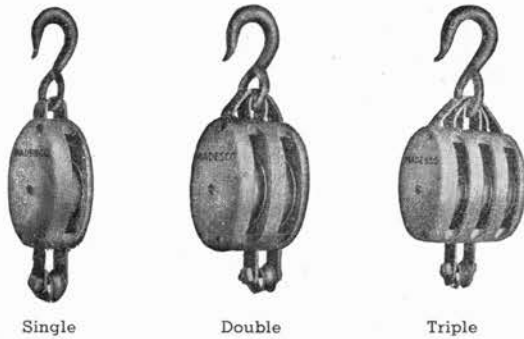

For manila rope. Loose side hooks and becketts. Can be supplied with common or roller bushings. Roller bushings will be furnished unless otherwise specified.

Size Sheave Inches	Stock No. Single	Stock No. Double	Stock No. Triple	Size Shell In.
1 3/4 x 1/2	(892558)	(892564)	(892571)	3
2 1/4 x 5/8	(892559)	(892566)	(892572)	4
3 x 3/4	(892560)	(892567)	(892573)	5
3 1/2 x 1	(892561)	(892568)	(892574)	6
4 1/2 x 1	(892562)	(892569)	(892575)	7
4 3/4 x 1 1/8	(892563)	(892570)	(892576)	8

**MALLEABLE IRON PULLEY BLOCKS**

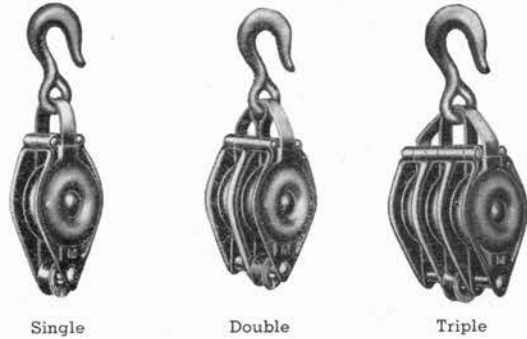

Constructed so that manila rope cannot jam between shell and sheaves. Hooks are drop forced of special steel.

Can be furnished with either common iron or roller bushings. Roller bushings will be furnished, unless otherwise specified.

Size Sheave Inches	Stock No. Single	Stock No. Double	Stock No. Triple	Size Shell In.
1 3/4 x 1/2	(892577)	(892583)	(892589)	3
2 1/4 x 5/8	(892578)	(892584)	(892590)	4
3 x 3/4	(892579)	(892585)	(892591)	5
3 1/2 x 1	(892580)	(892586)	(892592)	6
4 1/4 x 1	(892581)	(892587)	(892593)	7
4 3/4 x 1 1/8	(892582)	(892588)	(892594)	8

## KLEIN'S CLIMBER STRAPS AND PADS

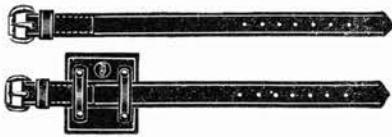

Set consists of 2 calf straps 1 1/4 x 22 inches with 4 x 4-inch pads and 2 ankle straps 1 1/4 x 22 inches. Leather is first quality harness leather. Buckle drop forged, fitted with roller.

Cat. No.	Stock No.	Description	Wt. Lb. per Doz. Sets
5301-1	(892608)	Plain Pads	15
5301-2	(892609)	Sheep-lined Pads	16
5301-3	(892610)	Felt-lined Pads	16

### Straps Only

Cat. No.	Stock No.	Description	Wt. Lb. per Doz. Pair
5301-4	(892611)	Plain Straps, 2 Straps	6
5301-5	(892612)	Plain Straps, Plain Pads, 2 Ea.	9

## KLEIN'S CLIMBER STRAPS AND PADS



### Bell System Type

Set consists of 2 calf straps 1x22 inches with 2 special pads and 2 ankle straps 1x26 inches.

Cat. No.	Stock No.	Description	Wt. Lb. per Doz. Sets
5301-6	(892616)	With Plain Pads	14
5301-7	(892617)	With Sheep-Lined Pads	15
5301-8	(892618)	With Felt-Lined Pads	15

### Straps Only

Cat. No.	Stock No.	Description	Wt. Lb. per Doz. Pair
5301-9	(892619)	2 Calf Straps, 1x22 In.	6
5301-10	(892620)	2 Ankle Straps, 1x26 In.	8

### Pads Only

Pads made of select leather, arranged with loops for climber straps and climber. Tapering 3 3/4 inches to 2 3/4 x 6 1/4 inches deep.

Cat. No.	Stock No.	Description	Wt. Lb. per Doz. Pair
8203	(892621)	Plain Leather	4
8204	(892622)	Sheep-Lined Leather	5
8205	(892623)	Felt-Lined Leather	5

## KLEIN'S CLIMBER PADS

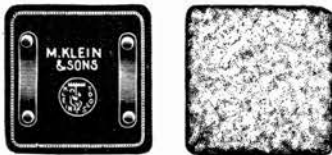

Pads made of select leather, arranged with loops through which to slip climber strap.

Cat. No.	Stock No.	Description	Wt. Lb. per Doz. Pair
8200	(892613)	Sheep-lined, 4x4 Inches	3
8201	(892614)	Felt-lined, 4x4 Inches	3
8202	(892615)	Plain Leather, 4x4 Inches	3

## BUCKINGHAM CLIMBER PADS

Only top grades of leather are used in the manufacture of Buckingham Climber pads. A wide variety of design and types has made these pads extremely popular. Provided with pads of rubberized wool or felt, or without padding, they are "tailor-made" for Buckingham climbers. Users will find them most comfortable.

### Deluxe Climber Pad No. 3122

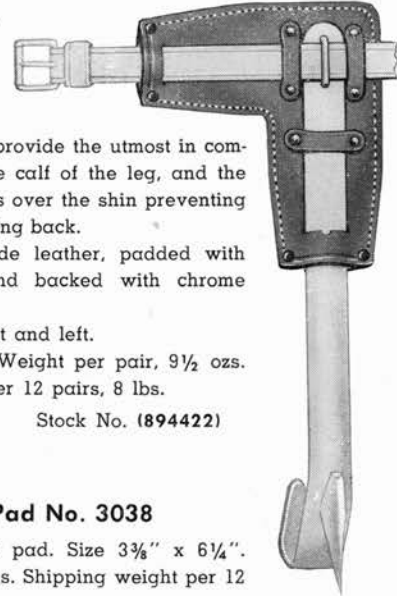

These climber pads provide the utmost in comfort. They protect the calf of the leg, and the wing of the pad folds over the shin preventing the climber from sliding back.

Made of high-grade leather, padded with rubberized wool, and backed with chrome leather.

Made in pairs right and left.

Size 6 3/4" x 7 3/4". Weight per pair, 9 1/2 ozs. Shipping weight per 12 pairs, 8 lbs.

Catalog No. 3122 Stock No. (894422)

### Climber Pad No. 3038

3-Loop plain leather pad. Size 3 3/8" x 6 1/4". Weight per pair, 5 ozs. Shipping weight per 12 pairs, 5 lbs.



	Catalog No.	Stock No.
Plain Leather	3038	(894418)
Felt Lined	3238	(894419)

### Climber Pad No. 3039

2-Loop plain leather pad. Size 4" x 4". Weight per pair, 3 ozs. Shipping weight per 12 pairs, 3 lbs.



	Catalog No.	Stock No.
Plain Leather	3039	(894410)
Felt Lined	3239	(894411)

## BUCKINGHAM CLIMBER STRAPS



Buckingham Climber Straps are made from two grades of leather and price varies accordingly. Harness leather straps are made from selected quality steer hides, and latigo leather straps are made from first quality cow hides. These straps are strong and durable, and fitted with tested steel buckles. The buckles on latigo leather straps are riveted on whereas the buckles on harness leather straps are sewn as well as riveted.

Cat. No.	Stock No.	Description	Size
2234	(894426)	Leg Strap, Harness Leather	1" x 22"
2434	(894427)	Foot Strap, Harness Leather	1" x 24"
2235	(894424)	Leg Strap, Harness Leather	1 1/4" x 22"
2435	(894425)	Foot Strap, Harness Leather	1 1/4" x 24"

**BUCKINGHAM CLIMBERS**

**Straight Pattern**

Buckingham Climbers are sturdy, dependable and comfortable — designed and tested to give maximum service and safety. The Buckingham Climbers listed below are made in straight pattern only, not left and right. Many large utilities throughout the country favor them. Each run of these climbers is rigidly inspected, and all lots are tested for metal specifications, including a Rockwell hardness test. Each lot must meet the "bend test" of shanks, gaffs, and other Buckingham high standards of safety.

Straight, Med. Wt. with loops

Weight, each 3 lb. 3 oz.

Cat. No.	Stock No.
9126	(894401)

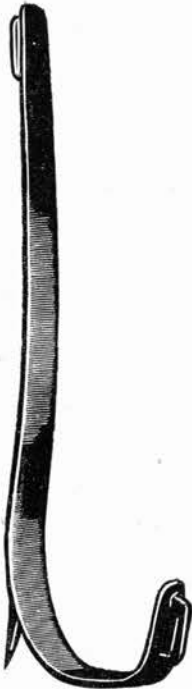

**Patented Offset Shanks**

The Buckingham Climbers listed below are Right and Left Climbers with Patented Offset Shank. Offset-shank climbers are becoming increasingly popular because of the new sense of safety, comfort and ease they give the wearer. The offset in the shank of the climber brings the gaff more in alignment with the wearer's balance when climbing, and greatly overcomes the tendency of climbers to twist and slide back of the wearer's leg.

Each climber is stamped "Right" or "Left," designating the foot for which it is intended.

Climbers No. 9130 and No. 9131 are extremely popular with linemen weighing not over 175 pounds. They are comfortable, sturdy and light. Footstraps are attached.



Cat. No.	Stock No.	Description	Wt. each
9130	(894517)	Straight, Featherweight with straps	2 lb., 13 oz.

**KLEIN CLIMBERS AND BELTS**

**NO. 1903 KLEIN'S LIGHTWEIGHT CLIMBERS**



Lightweight pattern with riveted strap loops. Packed 1 pair in a carton. Weight, 2 7/8 pounds. Stock No. (892607)

**NO. 1901M KLEIN'S STANDARD WEIGHT CLIMBERS**



When ordering specify length of shank desired. Measure from instep to extreme end. Other than stock sizes to order. Tested before leaving factory.

Stock sizes, 15, 15 1/2, 16, 16 1/2, 17, 17 1/2 and 18 inches.

Has punched strap loops. Packed 1 pair in a carton. Weight, 3 5/8 pounds. Stock No. (892606)

**NO. 5228 KLEIN'S LEATHER TOOL BELTS**



Made 4 1/2 inches wide at center of back and tapered to 3 1/2 inches wide at front. Made of one-piece soft, pliable russet latigo leather, doubled to form comfortable rolled edges and returned at each end.

Standard D rings are single bar type solid steel drop forgings as is the buckle. Galvanized finish.

Sizes, 36, 38, 40, 42, 44 and 46 inches. Other sizes to order. Specify length when ordering.

Weight per dozen, 45 pounds. Stock No. (892627)

**KLEIN'S TOOL BELTS**

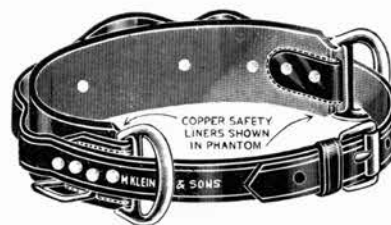

DROP FORGED DEE RINGS AND BUCKLE

Drop forged standard D rings and buckle.

Made in sizes 36, 38, 40, 42, 44 and 46 inches. Specify length required.

Cat. No.	Stock No.	Width Inches	Wt. Lb. per Doz.
5204	(892624)	3 1/2	32
5205	(892625)	*2 1/4	33

\*Double thickness.

## NO. 5204-TSO KLEIN'S TEXAS TOOL BELTS



Lined throughout with soft latigo leather. Made 4 inches wide at center of back for full support, tapering to 2 1/4 inches wide at hips to permit free bend to body of wearer.

Made in sizes 36, 38, 40, 42, 44 and 46 inches. Specify length required. Weight per dozen, 33 pounds. Stock No. (892626)

## NO. 5229-S KLEIN-LINE TOOL BELT

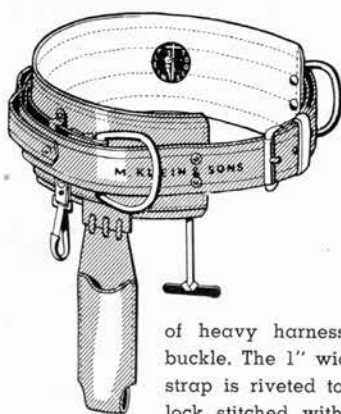

The trace moves or slides freely through alloy steel guides, allowing a movement in either direction of approximately 6 inches. By this means the lineman is relieved of the chafing that is unavoidable with conventional belts, and undue wear on the safety strap is prevented.

The 2" wide belt strap is of heavy harness leather with drop-forged buckle. The 1" wide harness leather tool loop strap is riveted to the main strap. Sewing is lock stitched with hot waxed linen thread—

rivets are solid copper hand set.

The cushion is 4 1/2" wide of pliable latigo leather with canvas interlining. The edges are rolled and smooth.

Furnished complete with plier pocket, tape thong, and knife snap.

Cat. No.	Stock No.	Width	Wt. per Doz.
5229-S	(894861)	4 1/2"	54 Lb.

## KLEIN'S PLIER POCKETS



No. 5107

No. 5118-K

No. 5112

Made of good quality leather. Have slits through which belt is inserted. No. 5112 is the same as No. 5107 except that plier does not protrude.

Weight per dozen, 2 1/2 pounds.

Catalog No.	Stock No.
5107	(892636)
5112	(892637)
5118-K	(894862)

## BUCKINGHAM ADJUSTABLE CLIMBERS

### No. 9205



All the desirable features of Buckingham Climbers have been incorporated in the design and manufacture of these radically new adjustable climbers. The same old reliable safety and comfort features will be found in them.

Buckingham Adjustable Climbers can quickly be adjusted from size 15 to size 18 1/2 by a simple and secure setting of two Allen-head set screws against a loop made from round cold-drawn steel, adjustable in a tubular steel socket. This extensible device gives a range of leg iron lengths that are exact-size fit for any wearer.

Buckingham Adjustable Climbers make it possible for linemen to adjust them according to the various thickness of footgear worn at different times during the year.

**REPLACEABLE GAFFS**—The replaceable gaff is locked to the body of the climber at an angle which will not permit it to become disengaged in normal use. Pressure exerted on it when the wearer is ascending or descending tends to lock the gaff tighter into the leg iron. The angle of the gaff permits the lineman to stand closer to his work with less possibility of cut out, and also makes climbing easier.

Styled like the regular gaff, the removable gaff has an integral lug machined for a precision fit into the broached hub or boss of the climber. They can be removed by using a punch or drift pin to drive out a patented "Driv-Lok" pin. Extra gaffs are available.

Catalog No. 9205 Stock No. (894700)

## BUCKINGHAM GAFF PROTECTORS

### No. 6009



These gaff protectors are made in pairs from high-grade leather and secured with binder strap. They protect the gaff from damage and prevent accidents to workmen and equipment when carried in service truck.

Weight per pair, 2 ozs.

Shipping weight per 12 pair, 2 lbs.

Cat. No. 6009, Stock No. (894423)

### How to Order Buckingham Climbers

When ordering climbers it is necessary that the size (length) be given, as well as the type of climbers wanted . . . and the catalog numbers. Climbers are measured from the bottom of the stirrup, or footpiece, to the extreme end of the shank . . . see diagram and table of sizes. The top of the shank should normally extend about one-half inch below the inside low point of the knee joint.

### Climber Sizes

Buckingham Climbers are made in lengths of 14", 14 1/2", 15", 15 1/2", etc., in increments of 1/2" to 19" . . . in Medium, Light and Featherweights. Buckingham also makes adjustable climbers.

### Climber Markings

Each climber is stamped with the size: 15 1/2, 16, 16 1/2, etc., and right and left climbers are stamped:

16	16
Right	Left

**KLEIN'S SAFETY STRAPS**



Drop forged snaps and buckle.

**With Leather Wear Pads**

Cat. No.	Stock No.	Width Inches	Length Feet	Type Snaps	Wt. Lb. per Doz.
5251	892628)	1 3/4	5 2/3	Standard	32 1/2

**With Stainless Clips**

5250	(892629)	1 3/4	5 2/3	Standard	32 1/2
5253	(892630)	2	5 2/3	Standard	40

**Bell System Type**

5257S	(892631)	2	5 1/8	-----	38
5257L	(892632)	2	5 5/6	-----	40

**KLEIN'S KLEIN-KORD SAFETY STRAPS**



**With Stainless Clips**

Cat. No.	Stock No.	Width Inches	Length Feet	Type Snaps	Wt. Lb. per Doz.
5233	(892633)	1 3/4	5 2/3	Standard	36

**NO. 5111 KLEIN'S HIP POCKET TOOL CASES**

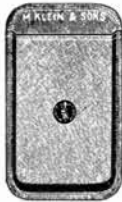

This case is suitable for carrying pliers or other tools in hip pocket.

Prevents cutting of clothes, or possible injury to the person.

Made of black leather.

Size, 5 x 7 inches.

Weight per dozen, 2 1/2 pounds.

Stock No. (892638)

**BUCKINGHAM BELT SUPPORT NO. 6258**



This belt supporter will provide comfort and working ease when carrying a heavy tool belt, because the greater share of the weight will be supported from your shoulders. Made of highest quality leather and fitted with necessary dee rings and snaps. Weight 10 ounces. Shipping weight per 12, 8 lbs.

Catalog No. 6258 Stock No. (894451)

**BUCKINGHAM TOOL BELTS**

**Buckingham Glider Tool Belt No. 1060**



Buckingham's Glider-type Lineman's Belt No. 1060 embodies a "floating" feature that provides fuller freedom of body movement under all working conditions, 4 1/2 inch shift, right or left without binding clothes or tools. Weight of the body does not bind, or affect in any way, the sliding-strap ease in shifting positions. The 4 inch, rolled-edge chrome leather liner further contributes to wearing and working comfort.

Belt is equipped with a two-way snap, and rings for attaching belt supporter.

Weight 4 pounds. Shipping weight per 12, 58 lbs.

Catalog No. 1060 Stock No. (894531)

**"Cushion Deluxe" Floating Tool Belt No. 1058**



No. 1058 is a strong, durable and flexible belt made from the best leather obtainable for the purpose. It has a rolled-edge feature providing a cushion effect that affords greater working comfort for the wearer.

The tool loop strap is formed into five loops with two rivets between loops to prevent twisting and sagging.

Belt is fitted with ring, two-way snap and tape thong. Belt is 4 3/4" wide, sliding strap 2" wide.

Rigidly tested for strength and safety.

Weight 3 lbs., 12 ozs. Shipping weight per 12, 56 lbs.

Catalog No. 1058 Stock No. (894438)

## BUCKINGHAM SAFETY STRAPS



Leather in Buckingham safety straps and belt straps must have an ultimate breaking strength of not less than 650 pounds per inch of width. It must be free from brittleness and show no cracking or grub holes, other than slight surface checks, when bent slowly with the grain side out. This bending test is around a mandrel of 0.675-inch diameter.

Nylon thread has a greater tensile strength than other commonly used stitching materials. It wears better, it is more elastic, it "gives" with the leather, its use is approved by utilities. Nylon thread is used in all Buckingham belts, safety straps and climber straps.

3042 (894452) 2" x 5' 10" Harness Leather 2 lb., 15 oz.  
 3142 (894453) 1 3/4" x 5' 10" Harness Leather 2 lb., 11 oz.

## BUCKINGHAM FABUCK (fabric)

### Safety Strap No. 3542



Particularly light and flexible, this strap is made from heavy silver duck, impregnated with neoprene and built up in vulcanized plythicknesses to meet various service requirements. It has a tensile strength of 300 lbs. per square inch, per ply. Tensile strength of 3700 lbs. per square inch. Superior to leather for tower work.

The fabric is specifically designed to meet specifications for a fabric belt. Its extra width increases its flexibility, correcting a fault found in other belts of this type. There are no sharp edges to cause excessive wear. Size: 2" x 5' 10". Weight 3 lbs., 2 ozs. Shipping weight per 12, 43 pounds.

Cat. No. 3542 Stock No. (894460)

## BUCKINGHAM TOOL POUCHES



No. 4650, tool pouch with one large, two small, and two deep ring pockets for various tools, fitted with knife snap. Size 8 1/2" x 10". Made from best quality harness leather, stitched and riveted. Easily slipped on any belt not over 2" in width.

Weight per pouch, 11 ounces. Shipping weight per 12, 10 lbs.



No. 4652, pouch with one large and two smaller pockets. Holds plier, rule, screwdriver or other tools. Fitted with knife snap. Size 5" x 10". Stitched and riveted harness leather, this pouch can be used to good advantage on any belt not more than 2" wide.

Weight per pouch, 9 ozs. Shipping weight per 12, 8 lbs.

Catalog No. 4650 Stock No. (894536)  
 Catalog No. 4652 Stock No. (894538)

## BUCKINGHAM SHARPENING GAGE

No. 6101

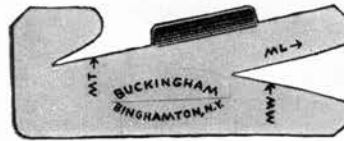

The Buckingham Gaff Gage is designed to guide linemen and others in the proper sharpening of gaffs for Buckingham Climbers.

The gage shows the minimum thickness and width of gaffs, as well as the minimum length allowable for safe use. The gage is packed in a leather pouch.

Weight per gage, 2 ozs. Shipping weight per 12, 2 lbs.

Catalog No. 6101 Stock No. (894408)

## KLEIN'S CANVAS TOOL BAGS

Made of one piece white duck reinforced all around bottom with heavy bag leather, 3/4 inches up on 5102 series, 8 inches up on 5105 series.

Bottom is made of heavy leather outside and duck inside, lock stitched all around. Bottom is protected with strong steel studs.

Bottoms and sides joined together with lock stitched leather welt seams.

Mouth of bag is formed by a 12-gauge steel frame.

Canvas is clinched between this frame and an inside secondary steel frame.

Has harness leather handles and two retaining straps with buckles.



No. 5102

Cat. No.	Stock No.	Size Inches	Wt. Lb.
5102-18	(892641)	18	3 3/4
5102-20	(892642)	20	3 7/8



No. 5105

5105-18	(892643)	18	4 1/2
5105-20	(892644)	20	4 3/4

**BUCKINGHAM CANVAS BAGS**



Here's a carry-all that will hold your belt, safety strap, climbers, pouches, tools, and a few extras, work clothes, etc. This zipper-closing, heavy olive drab canvas bag is reinforced in the bottom with stout binder board and fitted with heavy plated gliders. Heavy web straps are stitched to the sides and around the bottom of the bag and brought up in loops to form the carrying handles.

These web straps reinforce the bag and provide comfortable handles that won't tear or pull out. All seams are stitched to withstand the rugged service for which this bag is intended. Furnished in three sizes 20", 22" and 24" long.

Cat. No.	Stock No.	Description	Wt., Each
5320	(894548)	20" x 10½" x 12"	2 lb., 15 oz.
5322	(894549)	22" x 10½" x 12"	3 lb.
5324	(894550)	24" x 10½" x 12"	3 lb., 2 oz.

**NO. 1084 CANVAS BUCKET**



The Bell Telephone System style. Made of No. 1 white duck, 12" diameter at top, 9" diameter at bottom, height 12". Bottom is ⅛" leather pressed to shape, hardened and waterproofed. Equipped with spliced ⅜" rope handle in which has been placed a heavy galvanized swivel marine snap for hoisting, suspending from wires, etc.

Stock No. (892647)

**NO. 1324 COLLAPSIBLE NON-METALLIC BUCKET**



For heavy duty. Made of No. 1 white duck, diameter at top and bottom 12", 16" high. ½" non-metallic ring at top made of vulcanized hard fibre. Bottom reinforced with genuine full grain harness leather which extends up to the sides for 3". ⅜" rope handle spliced in heavy leather reinforcement.

Stock No. (892648)

**KLEIN'S LEATHER TOOL BAGS**



Made of harness leather and will stand rough usage. Has a shoulder strap combined with a pad and hand strap; also a saw and bit holder. Bottom is 3-ply and studded with steel studs. Retaining straps pass clear around the bag.

Seams are sewed with hot waxed linen thread, lock-stitched.

Cat. No.	Stock No.	Size Inches	Wt. Lb.
5108-18	(892639)	18x8	4½
5108-20	(892640)	20x8	5⅞

**NO. 1018 METAL TOOL KITS**

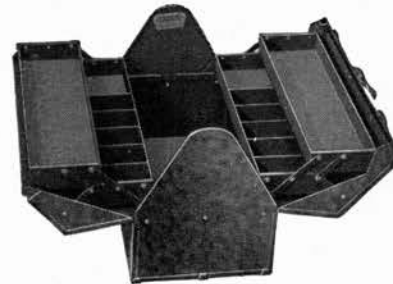

The four trays swing out of kit smoothly and easily when lids are opened.

Leather handle, lids fastened with draw bolt hasp and staple. Three skid rails welded to bottom.

Finished in seal brown ripple baked enamel outside, with dark green smooth baked enamel trays.

Dimensions, 18 x 10 x 12½ inches. Each kit packed in individual carton; 6 to a crate.

Shipping weight per crate, 115 pounds. Stock No. (892645)

**NO. CS19 METAL TOOL KITS**



Cantilever style, has smooth working tray which rests firmly when extended. Marproof green baked ripple enamel finish. Fastened with draw bolt hasp and staple, double seamed ends, full length piano (continuous) hinge, and corner irons.

Dimensions, 19 x 7 x 7 inches. Each kit packed in individual carton; 6 to a crate.

Shipping weight per crate, 48 pounds. Stock No. (892646)

## NO. 261 SOCKET FRAMING CHISEL



Sturdily built blade with extra heavy cross-section of solid steel withstands long, rugged use. Socket is of heavier gauge and is longer and larger than required on comparatively light firmer chisels. Bevel-edged blade, socket and handle are fully polished. Conveniently long hardwood handle with nickel plated, pressed steel ring. Blade length 8". Over-all length 16" to 17½" according to size. Standard package: ½ dozen boxed. Stock sizes listed below.

### Sizes and Weight Per Dozen

Size	Stock No.	Weight in Pounds	Size	Stock No.	Weight
¼"	(892666)	7½	1¼"	(892673)	16
½"	(892668)	8¼	1½"	(892674)	18
¾"	(892670)	11	2"	(892676)	24
1"	(892672)	13½			

## DIE CAST BASTARD MILL FILE



Length Inches	Stock No.	Approx. Size Inches	Number in Box	Approx. Wt. per Doz.
10	(892677)	1x¾	1 doz.	5 lbs., 3 oz.
12	(892678)	1¾x7/32	½ doz.	9 lbs., 1 oz.
14	(892679)	1¾x¼	½ doz.	13 lbs., 2 oz.

Shown below are some of the Stromberg-Carlson Switch-board Tools which are described in Section F of this catalog.

## PLUMB BALL PEIN HAMMERS



Advertised Finish—Smooth Black Head, Red Handle and Take-up Wedge Head tempered to maximum degree of hardness for toughness and strength. Pein is cone shaped to spread rivets easily. Balanced for control with weight centered behind face.

Cat. No.	Stock No.	Size	Weight	Handle Lgth.
372	(892684)	2/0	12 oz.	12½"
373	(892685)	0	1 lb.	14"
374	(892686)	1	1¼ lb.	14"
375	(892687)	2	1½ lb.	15½"

## PLUMB NAIL HAMMERS



Advertised Finish—Smooth Black Head, Red Handle and Take-up Wedge. Shape, design and balance insure a true blow. Curved claws, with sharp split, catch closely-driven nails. Comfort grip hickory handle shaped to prevent slipping.

Cat. No.	Stock No.	Size	Wt. of Head	Handle Lgth.
80	(892680)	11	1¼ lb.	13½"
81	(892681)	11½	1 lb.	13"
82	(892682)	12	13 oz.	12"
83	(892683)	13	7 oz.	11½"



No. 2



No. 7



No. 14



No. 27



No. 39



No. 40



No. 42



No. 44



No. 45



No. 47



No. 48



No. 52



No. 53



No. 54



No. 55



No. 63

STROMBERG-CARLSON

**PLUMB BROAD HATCHETS**



Advertised Finish—Smooth Black Head, Red Handle and Take-up Wedge. A heavy tool with broad single bevel cutting edge. Designed to square or true-up lumber. Made of special analysis steel—heat treated and tempered to hold a keen edge. Handles of second growth hickory tested for strength. Designed for hand comfort.

Cat. No.	Stock No.	Size	Bit Inches	Handle Lgth.
2992	(892689)	2	4½	15½"
2994	(894760)	4	5½	15½"

**PORTER NEW EASY POWER CUTTERS**

**Clipper Cutter  
Rigid and Swivel Types**



Clipper Cut Jaws are beveled mostly on one side so that cutting may be done close up to the nut or surface of the work. The cutting jaws of the Rigid type are firmly fixed in line with the handles while in the Swivel type the cutterhead may be swiveled within a 180° arc into any position so that cutting pressure can be applied in a normal position. New Models feature curved handles and improved hand grip for stronger pull and easier cutting. Specify whether rigid or swivel type is required when ordering.

Clipper Cut Jaws in either rigid or swivel type are recommended for all around work in softer metals requiring close cutting.

NOTE: Clipper Cut Tools are not recommended for cutting concrete reinforcing rods.

**Rigid Clipper Cutter**

Tool Designation	Stock No.	Approx. Length of Tool	— Capacities —		Approx. Wt. Lb.
			Annealed Bolts in Thread	Soft Rods	
0 NE	(892598)	18"	¾"	5/16"	4¼
1 NE	(892599)	24"	7/16"	¾"	6¾
2 NE	(892600)	30"	9/16"	½"	10½
3 NE	(892601)	36"	¾"	9/16"	14¾

Center Cut tools are recommended in all cases where close cutting is not a requirement and for material up to 300 Brinell hardness. Specify whether rigid or swivel type is required when ordering.

**Rigid Center Cutter**

Tool Designation	Stock No.	— Capacities —		Approx. Wt. Lb.
		Annealed Bolts in Thread	Soft Rods	
0 NE-CC	(892602)	¾"	5/16"	4¼
1 NE-CC	(892603)	7/16"	¾"	6¾
2 NE-CC	(892604)	9/16"	½"	10½
3 NE-CC	(892605)	¾"	9/16"	14¾

**SPINTITE SOCKET WRENCHES**



Made like a screwdriver. The shaft is hollow, and the head is hexagon shaped, formed to engage hexagon nut.

Packed 6 in a box.

Cat. No.	Stock No.	Hexagon Size In.	Lgth. In.
3406	(892700)	3/16	6
3407	(892701)	7/32	6
3408	(892702)	¼	6
3409	(892703)	9/32	6
3410	(892704)	5/16	6
3411	(892705)	11/32	6
3412	(892706)	¾	6
3414	(892707)	7/16	7½
3416	(892708)	½	7½
3418	(892709)	9/16	7½
3420	(892710)	¾	7½

**DI-FORGE TWIST DRILLS  
For Hammer Drilling**



Forged from a solid bar of vanadium tool steel. Used with a hand or electric hammer. Rotate clockwise between each blow if used with hand hammer. Rotate continuously if used with electric hammer. Will stand hard use and abuse.

Diameter Inches	Stock No.	Length Overall In.	Depth Hole In.	Wt. Lb. per Doz.
3/16	(890086)	2¾	1¾	½
1/4	(890087)	3¼	1¾	¾
5/16	(890088)	4¼	2½	1
3/8	(890089)	5	3	1¼
7/16	(890090)	5¼	3¼	1½
1/2	(890091)	5¾	3¼	2
9/16	(890092)	5½	3¾	2½
5/8	(890093)	5¾	4	2½

**STYLE B DRILL HOLDERS**



A hand drilling tool for electricians and in other lines of industry where numerous small holes are to be drilled for fastening small fixtures, etc.

Either Di-Forge or Diamond N drill points may be used.

Weight per dozen, 6½ pounds. Style B. Stock No. (890094)

**STYLE C RUBBER GRIP DRILL HOLDERS**

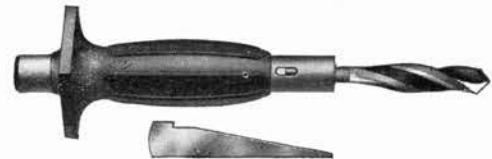

Made of vanadium steel, with a soft rubber grip with flange to protect the hand of the operator. Hexagon flange to prevent rolling.

Weight per dozen, 10 pounds. Style C. Stock No. (890095)

## N 4-POINT OR STAR DRILLS



Made of high grade octagon drill rod. The quality of steel is carefully tested for uniformity and actual tests are made in various kinds of stones to insure a temper that will give the best average service in all.

The heat treatment is scientifically conducted.

Heats for hardening and drawing the temper are determined by pyrometer and thermometer. These two methods give greater accuracy and uniformity than can be had by determining the heat by color.

Diameter Drill In.	Stock No.	Wt. Lb. per Dozen—Length		
		12"	18"	24"
1/4	(890096)	2 7/8	3	3 1/2
5/16	(890097)	2 1/2	3 3/8	5 1/8
3/8	(890098)	3 3/4	5	7 1/8
7/16	(890099)	5	7	9
1/2	(890100)	5	7 3/4	10 1/4
9/16	(890101)	9 1/4	13 3/4	18 1/4
3/4	(890102)	11 1/2	16 3/4	22 1/4
7/8	(890103)	14	20 1/2	27 1/2
1	(890104)	20	30	40
1 1/8	(890105)	28 1/2	42	54
1 1/4	(890106)	28 1/2	42 1/2	57
1 3/8	(890107)	35	53	72
1 1/2	(890108)	36	54	72

## ROTARY MASONRY DRILLS



Star Rotary Drills are made in two shank types to fit the ordinary type of portable drill or hand brace. Drills clean, sharp, accurate holes in all types of masonry. Also available in handy canvas kit of 6 drills.

Nominal Diameter	Stock No.	Overall Drill Lgth. (D)	Standard Carton Quantity	Shipping Wt.
3/16"	(894812)	3"	12	10 oz.
1/4"	(894813)	4"	12	14 oz.
5/16"	(894814)	4"	12	1 lb. 4 oz.
3/8"	(894815)	4"	12	1 lb. 6 oz.

## NO. 600 RAZOR BLADE DRAW KNIFE

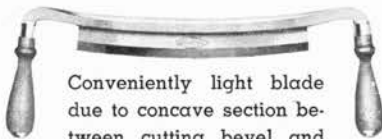

Conveniently light blade due to concave section between cutting bevel and rib, yet substantially stiff and rigid to guarantee

years of dependable service. Blade is 1 3/8" in width and constructed from a single solid piece of steel. Hardwood handles mounted on shanks which pass through handles and are securely riveted on top of nickel plated caps. Highly finished, sharpened, ready for use. Standard package: 1/2 dozen boxed. Stock sizes listed below.

### Sizes and Weight Per Dozen

Length	Weight in Pounds	Weight
9"	(894699)	14 1/2
10"	(892693)	18
12"	(892694)	18 1/2

## NO. 56 SOLID-CENTER CAR BIT



12-inch twist—18-inches over all

Provides greater range than an ordinary length auger bit. Single spiral and center stem gives a broad channel for clearance and elevation of chips. Head is extension-lip pattern and is fitted with medium coarse screw. Excellent for general wood work. Fully polished. Standard package, 1/2 dozen boxed. Stock sizes listed below.

### Sizes and Weight Per Dozen

Size	Size in Sixteenths—Weight in Pounds		Size	Stock No.	Weight
	Stock No.	Weight			
6	(892880)	2 3/4	13	(892887)	7 1/2
7	(892881)	3 1/4	14	(892888)	8 1/2
8	(892882)	4	15	(892889)	9
9	(892883)	5	16	(892890)	9 1/2
10	(892884)	5 1/2	17	(892891)	11
11	(892885)	6	18	(892892)	12
12	(892886)	6 1/2	20	(892894)	14 1/2

## NO. 57 SINGLE-SPUR CAR BIT



Designed for pole, bridge, dock and other heavy wood construction. Made of a tough alloy and heat-treated. Head fitted with single cutter with outlining spur to insure smooth boring and long life. Single-spiral twist provides smooth chip clearance. Fully polished. Standard package, 1/2 dozen boxed.

### Sizes and Weight Per Dozen

Size	Weight in Pounds		Size	Stock No.	Weight
	Stock No.	Weight			
7/16	(892915)	6 3/4	12/16	(892929)	15 3/8
8/16	(892916)	7 1/2	14/16	(892931)	16 1/2
9/16	(892917)	8 3/8	15/16	(892932)	22
10/16	(892918)	9 3/8	16/16	(892933)	22 1/2
11/16	(892919)	10 1/2	17/16	(892934)	25 1/2
12/16	(892920)	11 3/4	24" TWIST		
13/16	(892921)	12	9/16	(892935)	12 3/8
14/16	(892922)	13 1/2	10/16	(892936)	14 1/4
15/16	(892923)	15	11/16	(892937)	16 1/2
16/16	(892924)	16	12/16	(892938)	18 3/4
17/16	(892925)	17 1/2	13/16	(892939)	20 1/4
	18" TWIST		14/16	(892940)	24 3/8
9/16	(892926)	10 3/8	15/16	(892941)	24 3/4
10/16	(892927)	12	16/16	(892942)	29
11/16	(892928)	13 1/2	17/16	(892943)	33 1/2

Tools with 12-inch twist are 17 to 18 inches over all; with 18-inch twist, 23 to 24 inches over all; and with 24-inch twist, 29 to 30 inches over all. Prices on special sizes and lengths quoted on application.

## NO. 46 WOOD BORING BRACE DRILL



All-purpose wood-boring drill with specially treated head to withstand accidental contact with metal. Body of twist is amply heavy to give it strength, yet assures uninterrupted chip clearance. Edges of twist are carefully ground to give minimum friction with wood. Fully polished. Standard package, 1/2 dozen in box. Stock sizes listed below.

### Sizes and Weight Per Dozen

Size	Size in Thirty-seconds—Weight in Pounds		Size	Stock No.	Weight
	Stock No.	Weight			
4	(892860)	1/2	9	(892865)	1
5	(892861)	3/4	10	(892866)	1 1/4
6	(892862)	3/4	12	(892868)	1 3/4
7	(892863)	3/4	14	(892870)	2 1/8
8	(892864)	7/8	16	(892872)	2 5/8

**NO. 22 SOLID-CENTER AUGER BIT**



Has double-cutter head with extension lips and is fitted with medium-pitch screw point. Fully polished. Center stem adds stiffness and single spiral easily, cleanly elevates chips. Ideal for general woodworking requirements. Standard package: 1 1/8-inch and smaller, 1/2 dozen in box; larger sizes, 1/4 dozen in box. Listed sizes in stock.

**Sizes and Weight Per Dozen**

Size	Size in Sixteenths—Weight in Pounds		Size	Weight in Pounds	
	Stock No.	Weight		Stock No.	Weight
4	(892820)	1	13	(892829)	3 3/4
5	(892821)	1 1/4	14	(892830)	4
6	(892822)	1 1/2	15	(892831)	4 1/2
7	(892823)	1 3/4	16	(892832)	4 3/4
8	(892824)	2	17	(892833)	6
9	(892825)	2 1/4	18	(892834)	6 1/2
10	(892826)	2 1/2	20	(892836)	7 1/4
11	(892827)	3	22	(892837)	7 1/2
12	(892828)	3 1/2	24	(892838)	8 1/2

**NO. 48 BELL HANGER'S DRILL**



Of high-grade alloy steel, heat-treated for additional strength, so that drill will not be damaged if metal is encountered during drilling. Twist length 3 3/4-inch, overall length as listed below. A 3/32-inch hole is drilled about one inch from point for convenience in pulling wire. Packed 1/2 dozen in a box.

**Sizes and Weight Per Dozen**

Length	Size in Thirty-seconds—Weight in Pounds					
	Size	Stock No.	Weight	Size	Stock No.	Weight
12-inch	6	(892841)	1 1/4	12	(892844)	2 1/8
18-inch	6	(892847)	1 3/4	12	(892850)	3
24-inch	6	(892853)	2	12	(892856)	4
12-inch	8	(892842)	1 5/8	14	(892845)	2 7/8
18-inch	8	(892848)	2 1/2	14	(892851)	3 3/4
24-inch	8	(892854)	3 3/8	14	(892857)	5 5/8
12-inch	10	(892843)	1 3/4	16	(892846)	4
18-inch	10	(892849)	2 7/8	16	(892852)	6 1/8
24-inch	10	(892855)	3 5/8	16	(892858)	8

**NO. 64 SHIP AUGER CAR BIT**



Highly recommended for its strength, rigidity, easy cutting and free clearance. Has 12-inch twist and measures 17 to 18 inches over-all. Fully polished. Available in all sizes listed. Ship Auger Car Bits with twists longer than 12-inch are made to order. Standard stock package: 1/2 dozen boxed.

**Sizes and Weight Per Dozen**

Size	Size in Sixteenths—Weight in Pounds		Size	Weight in Pounds	
	Stock No.	Weight		Stock No.	Weight
4	(892895)	2	13	(892904)	10 1/2
5	(892896)	2 1/2	14	(892905)	12 3/4
6	(892897)	3 1/2	15	(892906)	14 1/2
7	(892898)	3 3/4	16	(892907)	16 1/2
8	(892899)	4 1/2	17	(892908)	17 1/2
9	(892900)	6	18	(892909)	19 1/2
10	(892901)	6 1/2	20	(892911)	21 1/2
11	(892902)	6 3/4	24	(892914)	31
12	(892903)	9 1/4			

**NO. 90 YANKEE PLAIN SCREWDRIVERS**



The blades and ferrules are finely polished; the handle is of hardwood with black satin finish.

Each blade is individually tested.

Packed 6 in a box.

Blade Length In.	Stock No.	Length Overall In.	Wt. Lb. per Doz.
1 1/2	(892711)	4 1/4	1 1/8
2	(892712)	5 3/4	1 1/2
3	(892713)	7 1/2	1 7/8
4	(892714)	9 1/4	2 7/8
5	(892715)	10 1/2	4 1/4
6	(892716)	11 3/4	4 1/2
8	(892718)	14	7
10	(892720)	16 3/8	10 1/8
12	(892721)	18 1/4	11 3/8
15	(892722)	21 3/8	13 1/4
18	(892723)	26 3/4	19 3/4

**NO. 92 YANKEE COMPO-TUFF SCREWDRIVERS**



Special alloy steel blade properly hardened and tempered. Fastened to Compo-Tuff handle.

Packed 6 in a box.

Blade Length Inches	Stock No.	Blade Diam. Inches	Overall Length Inches	Wt. Lb. per Doz.
4	(892726)	1/4	7 5/8	2 1/4
6	(892727)	5/16	9 5/8	3 3/4
8	(892728)	3/8	12 7/16	6

**NO. 92-1 1/2 YANKEE COMPO-TUFF STUBBY SCREWDRIVERS**



For close quarter work requiring an unusually strong screwdriver. Special alloy steel blade, properly hardened and tempered. Fastened to Compo-Tuff handle.

Blade length, 1 1/2 inches; blade diameter, 5/16 inch; overall length, 3 7/16 inches.

Packed 6 in a box.

Weight per dozen, 1 1/4 pounds. Stock No. (892729)

**NO. 95 YANKEE PLAIN SCREWDRIVERS**



**Cabinet Style**

The fastening of blade and handle is such that they cannot be loosened in use. The blades are tempered the entire length. Each blade individually tested.

The blades and ferrules are finely polished, the handle of hardwood finish in dull dead black. Packed 6 in a box.

Blade Length In.	Stock No.	Length Overall In.	Wt. Lb. per Doz.
1 1/2	(892730)	4 1/8	1 1/8
2 1/2	(892731)	6 1/4	1 3/8
3 1/2	(892732)	7 1/4	1 1/2
4 1/2	(892733)	8 1/4	1 5/8
5 1/2	(892734)	9 1/4	1 3/4
6 1/2	(892735)	10 1/4	2
8 1/2	(892737)	13	2 7/8
10 1/2	(892739)	15	3 1/8
12 1/2	(892740)	17	3 3/8
15 1/2	(892741)	20	3 7/8

## YANKEE-PHILLIPS SCREWDRIVERS



Polished alloy steel blade, properly tempered for use with Phillips head screw. Hardwood handle has inset shafts.

### Heavy Duty

Cat. No.	Stock No.	Blade Length Inches	Point Size	Overall Lgth. Inches	Wt. Lb. per Doz.
901	(892742)	3	1	6 <sup>7</sup> / <sub>8</sub>	1 <sup>1</sup> / <sub>2</sub>
902	(892743)	4	2	9 <sup>1</sup> / <sub>4</sub>	3
903	(892744)	6	3	11 <sup>5</sup> / <sub>8</sub>	4 <sup>1</sup> / <sub>2</sub>
904	(892745)	8	4	13 <sup>7</sup> / <sub>8</sub>	6 <sup>3</sup> / <sub>4</sub>

### Regular

941	(892746)	3	1	6 <sup>3</sup> / <sub>4</sub>	1 <sup>1</sup> / <sub>4</sub>
942	(892747)	4	2	9	2 <sup>1</sup> / <sub>2</sub>
943	(892748)	6	3	11 <sup>1</sup> / <sub>2</sub>	4
944	(892749)	8	4	14 <sup>1</sup> / <sub>4</sub>	6 <sup>1</sup> / <sub>2</sub>

## NO. 15 YANKEE RATCHET SCREWDRIVERS



It has on its blade a knurled washer, by means of which the blade can be turned with a finger and the thumb.

Chrome-plated. Packed 6 in a box.

Blade Length In.	Stock No.	Length Overall In.	Wt. Lb. per Doz.
2	(892759)	4 <sup>5</sup> / <sub>8</sub>	1 <sup>5</sup> / <sub>8</sub>
3	(892760)	5 <sup>7</sup> / <sub>8</sub>	1 <sup>3</sup> / <sub>4</sub>
4	(892761)	6 <sup>1</sup> / <sub>2</sub>	1 <sup>7</sup> / <sub>8</sub>
5	(892762)	7 <sup>3</sup> / <sub>4</sub>	2
6	(892763)	8 <sup>3</sup> / <sub>4</sub>	2 <sup>1</sup> / <sub>8</sub>
8	(892764)	10 <sup>7</sup> / <sub>8</sub>	2 <sup>3</sup> / <sub>8</sub>

## NO. 10A YANKEE RATCHET SCREWDRIVERS



Adjustment for right or left hand is made by slide. The bits are made from steel, properly tempered, ground and polished. All other metal parts are chromium-plated and buffed. Handles are made of hard wood, smoothly polished. Packed 6 in a box.

Blade Length In.	Stock No.	Length Overall In.	Wt. Lb. per Doz.
3	(892752)	7 <sup>5</sup> / <sub>8</sub>	4
4	(892753)	8 <sup>5</sup> / <sub>8</sub>	4 <sup>1</sup> / <sub>8</sub>
5	(892754)	9 <sup>1</sup> / <sub>2</sub>	4 <sup>3</sup> / <sub>8</sub>
6	(892755)	11 <sup>1</sup> / <sub>8</sub>	6 <sup>1</sup> / <sub>8</sub>
8	(892756)	13 <sup>1</sup> / <sub>2</sub>	7

## YANKEE RATCHET TAP WRENCHES

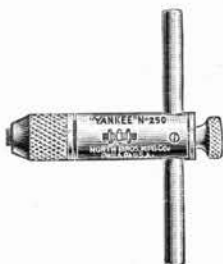

For working in close quarters, corners and inaccessible places. With the shifter at top, it is left hand; at bottom, right hand; and in center, rigid as ordinary tap wrench.

The cross bar is held central by a friction device and is of ample leverage for even larger taps than the chucks will hold.

Chrome-plated.

Cat. No.	Stock No.	Hold Taps Inches	O.D. Chuck Inches	Length Overall Inches	Weight Pounds Each
250A	(892810)	3 <sup>1</sup> / <sub>16</sub>	3 <sup>1</sup> / <sub>4</sub>	3 <sup>1</sup> / <sub>4</sub>	7 <sup>1</sup> / <sub>16</sub>
251A	(892811)	5 <sup>1</sup> / <sub>16</sub>	7 <sup>1</sup> / <sub>8</sub>	4 <sup>3</sup> / <sub>16</sub>	3 <sup>1</sup> / <sub>4</sub>

## YANKEE SPIRAL RATCHET SCREWDRIVERS

### Quick Return Style

Right and left hand and rigid.

This screwdriver has a spring in handle which causes the handle to come back for the next push similar to the automatic or push drills. This is more rapid and convenient than pulling handle back. This feature is especially valuable in driving screws in narrow or deep places where the left hand cannot hold chuck on end of tool. The spring keeps bit in position as it forces the handle back for the next stroke.

Three bits of different widths included with each tool.

Packed 1 in box.

### Size: Standard



Cat. No.	Stock No.	Length with Bit Extended In.	Closed In.	Wt. Lb. per Doz.
130A	(892765)	20	14 <sup>3</sup> / <sub>4</sub>	15

### Size: Heavy Pattern

131A	(892766)	28	19 <sup>3</sup> / <sub>8</sub>	24
------	----------	----	--------------------------------	----

### Size: Light Pattern



135	(892767)	13 <sup>1</sup> / <sub>2</sub>	10 <sup>1</sup> / <sub>4</sub>	8 <sup>1</sup> / <sub>4</sub>
-----	----------	--------------------------------	--------------------------------	-------------------------------

## YANKEE SPIRAL RATCHET SCREWDRIVERS

### Regular Style

Right and left hand, and rigid.

It drives or draws screws by pushing on handle, or by ratchet movement, and can be made rigid as an ordinary screwdriver by a lock when closed.

No. 35 has a knob handle instead of straight for use where large numbers of small screws are to be driven. No. 30A has straight handle. Three sizes of bits are furnished.

Packed 1 in a box.

Cat. No.	Stock No.	Length with Bit Extended In.	Closed In.	Wt. Lb. per Doz.
30A	(892768)	18 <sup>1</sup> / <sub>4</sub>	13	13 <sup>1</sup> / <sub>2</sub>
31A	(892769)	25	16 <sup>3</sup> / <sub>4</sub>	21
35	(892770)	12 <sup>3</sup> / <sub>8</sub>	9 <sup>1</sup> / <sub>8</sub>	7 <sup>1</sup> / <sub>2</sub>

## NO. 41 YANKEE AUTOMATIC DRILLS



This drill is intended for boring holes in wood for various purposes, as setting screws, brads, nails, etc. It can be used in many places where a gimlet, bradawl or brace cannot be used.

Drill point revolves in both directions. The backward turn on the upstroke of handle serves to free the chips. Points cannot be turned or pulled out of chuck in use. Eight sizes of drill points are furnished, 1<sup>1</sup>/<sub>16</sub> to 1<sup>1</sup>/<sub>64</sub> inch. They come into plain sight when magazine in handle is opened.

Made of steel and brass; chrome-plated and polished.

Packed 1 in box.

Cat. No.	Stock No.	Length Overall In.	Wt. Lb. per Doz.
41	(892790)	11 <sup>1</sup> / <sub>4</sub>	8 <sup>1</sup> / <sub>4</sub>

**YANKEE CHUCKS AND DRILL POINTS**

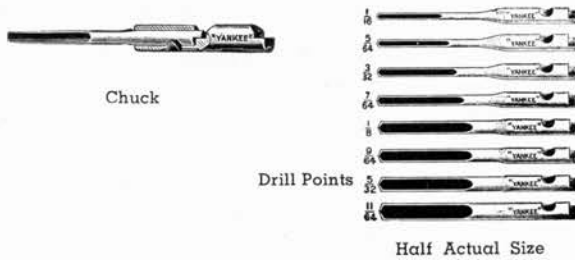

Used with spiral drivers in place of bit, making them automatic drills. Drill points exchange with Yankee Automatic Drills. Eight sizes, 1/16 to 11/64 inch. No. 35 uses three smallest only. Packed 1 set in wooden box.

Cat. No.	Stock No.	Diameter Shanks In.	Fits Screw Drivers No.
30A	(892775)	9/32	30A, 130A
31A	(894839)	5/16	31A, 131A
35	(892776)	7/32	35, 135

**YANKEE OFFSET RATCHET SCREWDRIVERS**

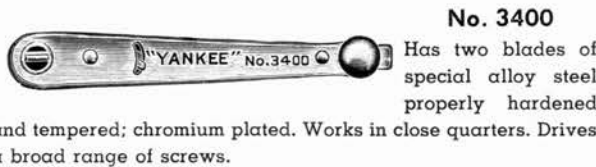

**No. 3400**  
Has two blades of special alloy steel properly hardened and tempered; chromium plated. Works in close quarters. Drives a broad range of screws.

Blade dimensions: small blade in head, 1/4 inch x .035; large blade in head, 3/8 inch x .045. Stock No. (892781)

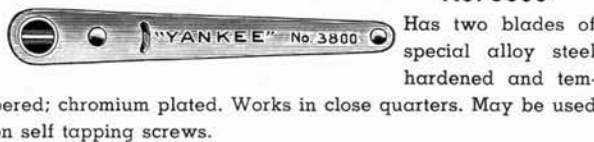

**No. 3800**  
Has two blades of special alloy steel hardened and tempered; chromium plated. Works in close quarters. May be used on self tapping screws.

Small blade, 3/8 inch x .045; larger blade, 7/16 inch x .060. Stock No. (892782)

**NO. 1431A YANKEE RADIO DRILLS**



Designed for radio work. A beautifully balanced, small, powerful drill with 4 to 1 ratio of gears for speed.

It is furnished with a special radio chuck, 9/32 inch capacity. Packed 1 in a box.

Cat. No.	Stock No.	Length Overall In.	Wt. Lb.
1431A	(892785)	9 3/8	1 1/4

**NO. 1530A YANKEE SINGLE SPEED RATCHET HAND DRILLS**



Die cast frame with dead black finish.

Has right and left-hand and continuous ratchet movements. Entire handle detachable; is hollow for drills. Spindle is of steel. Gears with cut teeth; large gear, 3-inch diameter; small gear, 7/8-inch. The crank is 2 3/4 inches long.

Handle is of polished hardwood, 4 inches long, 1 1/2-inch diameter. Chuck body is of steel, polished and chrome-plated. The three jaws are of tool steel.

Chuck holds round shanks only up to 9/32-inch diameter. Packed 1 in a box.

Cat. No.	Stock No.	Length Overall In.	Wt. Lb.
1530A	(892784)	10 1/2	1 1/4

**NO. 1446 YANKEE PLAIN HAND DRILLS**



Has fast and slow speeds, also a spindle lock for drill changing. Quick and handy speed shift by knurled sliding collar. Gears with cut teeth; large gear 4 inches in diameter. Malleable iron frame in dead black finish.

Three-jaw chuck, chrome-plated. Hardwood handle, detachable at milled nut, with deep drill magazine inside. Ball bearing on spindle. Chuck holds up to 3/8 inch.

Packed 1 in a box.

Cat. No.	Stock No.	Length Overall In.	Wt. Lb.
1446	(892788)	14 1/2	2 3/4

**NO. 1455 YANKEE PLAIN BREAST DRILLS**

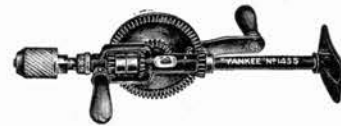

Capacity, 0 to 1/2 inch round shank drills.

Three-jaw chuck. Two speeds, changed by moving small shifter on main frame between small gears.

Speed changed without removing drill from work.

Steel spindle, adjustable ball bearings. Cut gears; steel pinions.

Black malleable iron frame; bright parts polished and chrome-plated. Side handle has screwdriver bit to adjust screws. Adjustable breast plate with polished face.

Packed 1 in a box.

Cat. No.	Stock No.	Length Overall In.	Wt. Lb.
1455	(892789)	16 1/2	6

## NO. 3423 YANKEE OFFSET RATCHET SCREWDRIVERS

For Phillips Recessed Head Screws



Length, 3 7/8 inches. Equipped with one each Nos. 2 and 3-point Phillips bits of special alloy steel. Chromium plated. Stock No. (892783)

## NO. 2101 YANKEE RATCHET BIT BRACES



Has ball-bearing chuck of new design with unusual grip. Firmly holds round, taper and square-shank bits without loosening in use, yet releases easily.

Capacity, 1/2-inch round shank, or 5/8" across corners of square shank.

Dust-proof, moisture-proof ratchet works so easily that most bits start without holding chuck.

Quick, positive shifter.

Handles of hard rubber, unbreakable and will not warp, shrink or swell.

Ball-bearing, steel-clad head. Packed 1 in a box.

Cat. No.	Stock No.	Sweep Inches	Wt. Lb.
2101-8	(892793)	8	3
2101-10	(892794)	10	3 3/8
2101-12	(892795)	12	3 1/4

## YANKEE VISES



Can be used on bench, or on a bench drill or other small machines. The vise is accurately machined all over so it can be used on either side or end as well as on base in drill press, etc. A hardened steel block with V-shaped grooves is provided for holding round or irregular shaped work.

Cat. No.	Stock No.	Jaws Inches				Overall In.		Wt. Lb.	
		Lgth.	Width	Open.	Depth	Width	Lgth.		
991	(892970)	3 5/8	1 1/2	1 1/2	7/8	1 1/2	1 1/2	4 5/8	1 3/8
992	(892971)	4 7/8	2	1 15/16	1 1/4	2	2 1/16	6	3 3/8
993	(892972)	7 1/4	2 3/4	3	1 7/8	2 3/4	3	8 3/4	9 5/16
994	(892973)	10 1/2	4	4	2 1/8	4	4 1/8	12 1/4	28

## YANKEE SWIVEL BASE VISES

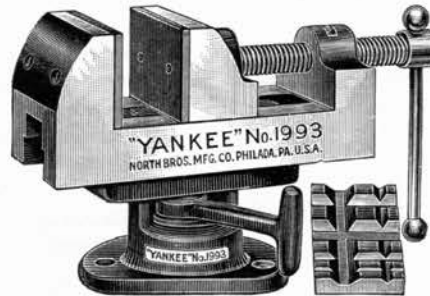

Can be used on bench, or on a bench drill or other small machine. Detached from base by loosening one screw.

Can be set on either side or end as well as on bottom in drill press, etc. A hardened steel block with V-shaped grooves is provided for holding round or irregular work.

Cat. No.	Stock No.	Diam. Swivel Base In.	— Jaws Inches —			Overall In.		Wt. Lb.
			Opening	Depth	Width	Hght.	Lgth.	
1991	(892974)	2 1/2	1 1/2	7/8	1 1/2	3 1/8	4 5/8	2 3/8
1992	(892975)	3 1/4	1 15/16	1 1/4	2	4 1/8	6	5 3/8
1993	(892976)	4 1/2	3	1 7/8	2 3/4	6 3/4	8 3/4	13 1/2
1994	(892977)	6 1/2	4	2 1/8	4	7 5/8	12 1/4	41

## NO. 2150 YANKEE BIT EXTENSIONS



The chuck is so constructed that it will accommodate a large range of square shanks and hold them securely. Square shank is held firmly by the socket.

A Yankee feature prevents jamming of the bit in the socket. The taper end of the shank is accurately machined. Bits will not loosen and come out while in use.

Chrome-plated throughout with high polish on sleeve.

Made to follow 1 1/16-inch bit or larger.

Packed 1 in a box.

Size Inches	Stock No.	Wt. Lb. Each
15	(892806)	1
18	(892807)	1 1/8
21	(892808)	1 1/4
24	(892809)	1 1/2

## YANKEE SCREWDRIVER BITS



Best grade steel, polished, notched to fit Yankee drivers; in set of 3. Packed one set in an envelope.

For Nos. 35 and 135—One each 5/32, 3/16, and 7/32-inch points. Length 3 inches.

For Nos. 31A and 131A—One each, 1/4, 9/32, and 5/16-inch points. Length 3 7/8 inches.

For Nos. 30A and 130A—One each, 7/32, 1/4, and 9/32-inch points. Length, 3 3/8 inches.

Stock No. (892771)

**YANKEE-PHILLIPS SCREWDRIVER BITS**

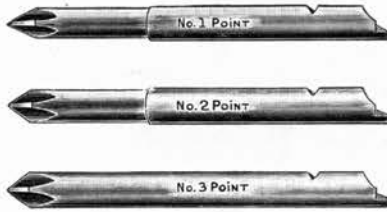

Point No.	Stock No.	Used with Yankee Spiral Screwdriver
1	(892772)	Nos. 30A, 31A and 35
2	(892773)	Nos. 30A, 31A and 35
3	(892774)	Nos. 30A and 31A

**NO. 651 LUFKIN BOXWOOD RULES**

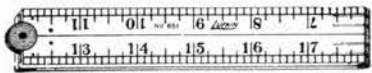

Round joint. Graduated in 8ths and 16ths. Two foot, four-fold, one inch wide. Middle plates with heavy, clear and distinct figures. Unbound.

Packed 12 in a box. Weight per dozen, 1 1/4 pounds.  
Stock No. (892944)

**LUFKIN RED END SPRING JOINT RULES**

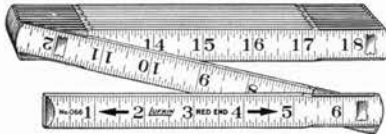

Lock joints and strike plates of solid brass.  
Finished in white enamel with gloss finish.  
Marked consecutive inches to 16ths, both edges, both sides.  
Six-inch folds, 5/8-inch wide.  
Can be furnished with the patent folding hook.  
Packed 6 in a box.

Cat. No.	Stock No.	Length Ft.	Weight Lbs. per Doz.
064	(892945)	4	2 1/4
065	(892946)	5	2 3/4
066	(892947)	6	3 1/2
068	(892948)	8	4 1/2

**LUFKIN STERLING LINEN TAPES**

Case is of genuine leather, metal lined, with a folding flush handle and nickel-plated trimmings.

Tape is 5/8-inch wide with leather reinforcements on first end.

Tape is marked on one side only; to feet, inches and 1/2 inches.

Packed 1 in a box.



Cat. No.	Stock No.	Length Ft.	Weight Ozs.
400	(892956)	25	8
403	(892957)	50	12
405	(892958)	75	19
406	(892959)	100	24

**COLD CHISELS**



These Cold Chisels are made of high carbon tool steel, dipped in rich black lacquer. Cutting edges only, polished.

Cat. No.	Stock No.	Size Stock	Cutting Edge	Length	Wt. Doz. Lb. Oz.
9401	(892657)	1/4"	5/16"	4 1/2"	13
9402	(892658)	5/16"	3/8"	5 1/4"	1
9403	(892659)	3/8"	7/16"	5 1/2"	2
9405	(892660)	7/16"	1/2"	5 3/4"	3
9406	(892661)	1/2"	5/8"	6"	3 8
9408	(892662)	5/8"	3/4"	6 5/8"	6 8
9413	(892663)	3/4"	7/8"	7 1/2"	10 12
9417	(892664)	7/8"	1"	7 3/4"	14 4
9423	(892665)	1"	1 1/4"	8"	20

**LUFKIN CHALLENGE STEEL TAPES**



Has Nubian finished 3/8-inch steel tape. Metal lined genuine leather case, nickel-plated trimmings, folding flush handle.

Measurements guaranteed accurate.

Nos. 260 to 266 are marked in feet, inches and eighths.

Packed 1 in a box.

Cat. No.	Stock No.	Length Ft.	Weight Ozs.
260	(892960)	25	8
263	(892961)	50	11
265	(892962)	75	17
266	(892963)	100	21

**MICHIGAN CHAIN TAPES**

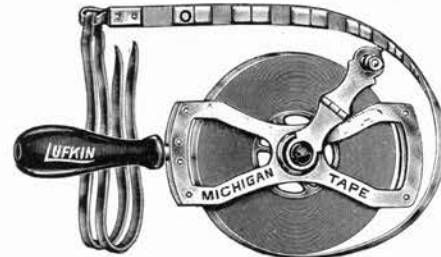

Line is of extra tough steel, white metal coated.

Graduations and figures are stamped into babbitt metal.

Line is detachable from reel, has heavy brass end clips, and is furnished with a pair of leather thongs.

Sturdy metal reel, in dull nickel-plated finish, with polished hardwood handle and long, folding winding handle.

Tapes over 100 feet long have 4-arm reel with D handle and spike end. Spike aids in holding reel when line is being withdrawn or rewound.

Width, 5/16 inch. Approximate thickness, .015 inch.

Marked in foot length with end feet in 10ths.

Furnished complete with reel.

Cat. No.	Stock No.	Length Feet
3100	(892965)	100
3150	(892966)	150
3200	(892967)	200
3300	(892968)	300
3500	(892969)	500

## NO. 345 1/4 INCH STANDARD HOLGUN BALL-BEARING DRILL

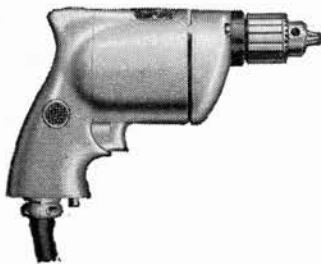

A perfectly proportioned "Handful of Power" of surprising compactness and smooth lines. Pistol Grip and Trigger Switch, special ball spindle bearing, splined gear mounting, screened air inlets and full ball-bearing equipped. Available in 7 spindle speeds from high torque at 500 R.P.M. to high

speed at 5,000 R.P.M. Use Standard Holgun for regular production service; Low-speed Holgun for stainless steel and hard alloys.

### Standard Speed Model Specifications

Drilling Capacity: in Steel, up to 1/4"; in Hardwood, up to 1/2"  
 Speed: No-load 1700 R.P.M.\* Full-load 900 R.P.M.  
 Weight: Net 3 lbs. Shipping 4 1/4 lbs.  
 Overall Length 6 3/4"  
 Spindle Offset 3/4"

\*Optional No-load Speeds (at no extra cost) 2500, 3500 or 5000 R.P.M.

### Standard Equipment

Two-pole automatic-release trigger switch and locking pin, mounted as a unit with cord protector; 3-wire cable and plug; 3-jaw Jacobs threaded chuck and key; "universal" motor.

Equipped with No. 24449 Chuck Protector at an extra charge. Standard Voltage, 110; also available for 220 or 250 volts. Catalog No. 345 (specify voltage) Stock No. (894763)

## NO. 361 1/2" STANDARD BALL-BEARING DRILL

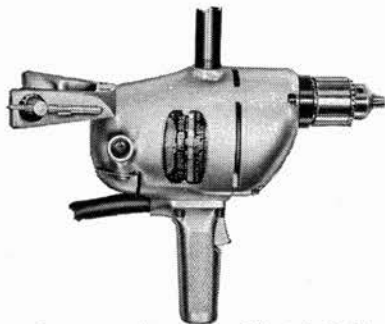

The most popular general purpose Electric Drill with perfect operating balance, close coupled construction, minimum spindle offset and horizontal spade handle. Spindle speed is ideal for driving all types of twist drills, hole saws and wood augers. Deep groove ball bearing on chuck spindle with inner and outer races locked in place. Spline-mounted spindle gear increases strength, minimizes friction and wear.

### Specifications

Drilling Capacity: in Steel, up to 1/2"; in Hardwood, up to 1"  
 Speed: No load 400 R.P.M., Full-load 275 R.P.M.  
 Weight: Net 9 3/4 lbs.; Shipping 13 lbs.  
 Overall Length 13 3/4"

### Standard Equipment

Three-conductor cable and plug; 3-jaw Jacobs threaded chuck and key; automatic-release trigger switch with locking pin; spade handle with key holder; detachable pipe handle; "universal" motor.

Standard Voltage, 110; also available for 32, 220 or 250 volts. Catalog No. 361 (specify voltage) Stock No. (894764)

## NO. 238 5/8 INCH STANDARD BALL-BEARING DRILL

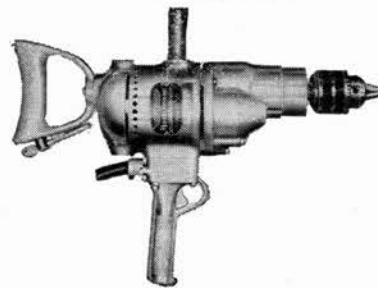

Motor is mounted on ball bearings. Chuck spindle operates on Timken tapered roller bearings, insuring smooth power.

### Specifications

Drilling Capacity: in Steel 5/32" to 3/4"; in Hardwood 1 1/4"  
 Speed: No-load 300 R.P.M.; Full-load 180 R.P.M.  
 Weight: Net 17 lbs.; Shipping 21 1/4 lbs.  
 Overall Length 18"

### Standard Equipment

3-wire cable and plug; 5/8" Jacobs chuck, key and chain; automatic-release switch with locking pin; spade handle; detachable pipe handle; "universal" motor.

Optional No. 2 Morse Taper Socket instead of chuck, no extra charge.

Standard Voltage 110; also available for 220 or 250 volts. Catalog No. 238 (specify voltage) Stock No. (894765)

## NO. 66 6 INCH STANDARD BENCH GRINDER

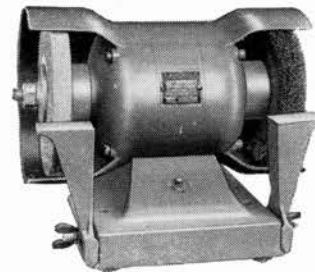

A sturdy, well-balanced Bench Grinder for practical shop use. Powered by a standard Black and Decker constant speed 1/4 H.P. motor.

Rotor and wheel spindle mounted on full-size bearings; special protective sleeves covering these bearings. Guards are case integral with motor housings.

Tool rests are locked in base grooves with wing nuts, and adjusted for wheel wear.

### Specifications

Wheel size 6" diam. x 5/8" face x 1/2" hole.  
 Motor, Not Universal. Supplied for all standard A.C. single-phase voltages and cycles only. Not available for Direct Current.  
 Motor rating, 1/4 H.P. (except 25 cycles, 1/5 H.P.)  
 Weight: Net 31 1/2 lbs.; Shipping 34 lbs.  
 Overall spindle length 12 1/4"; Overall height 10"  
 Height to center-line of spindle 5 1/2"

### Standard Equipment

3-conductor cable and plug; toggle switch in base; 4 rubber feet, 2 wheel guards, 2 tool rests. 1 medium grinding wheel, 1 wire wheel brush. Catalog No. 66 (specify 50 or 60 cycles, and 110 or 220 volts) Stock No. (894766)

**NO. 103 3/4 INCH PORTABLE ELECTRIC HAMMER**

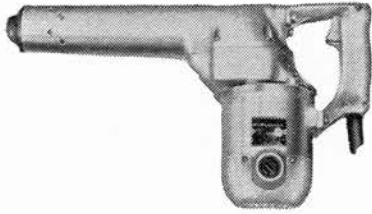

Completely self-contained, operated by "universal" motors, requires no transformers nor rectifiers. Positive motor drive, through reducing gears, develops hammer action by oscillating a weight and spring assembly. A definite "follow-through" stroke produces high efficiency.

Use to speed up any drilling or cutting operation requiring a hammer action; drill and channel in concrete, stone and brick; caulk joints and seams; remove scale and rust; tamp and vibrate concrete forms; gouge and chisel trees, timbers.

**Specifications**

Operating Range: Efficient 1/4" to 3/4"; Extreme 3/16" to 1 1/8"  
 Blows Per Minute 2300; Overall Length 14 3/8"  
 Weight: Net 10 3/4 lbs.; Shipping 22 lbs.

**Standard Equipment**

One No. 22587 chuck wrench; one dust shield; one No. 7162 (3/8") star drill; 3-conductor cable and plug; trigger switch; tool retaining spring; drift key; carrying case and can of oil; "universal" motor.

Standard Voltage 110 also available for 220 or 225 volts.

Catalog No. 103 (specify voltage) Stock No. (894767)

**MODEL AN DILLON DYNAMOMETERS**



This dynamometer makes it possible to obtain correct tension on telephone leads and thus insure freedom from wind, sleet and snow failures.

When used with block and tackle, it registers in pounds the strain load placed on wire, messenger or guy strand during initial installation or in maintenance work. Prevents overstrain and the resultant breakdowns, and eliminates guesswork.

Withstands full shock recoil; and mechanism cannot be injured by overload. The main indicator hand is white, and the maximum indicator hand is red. Dial is protected by 1/4-inch shatterproof safety glass, properly sealed to prevent the entry of dust or dirt.

Accuracy of 2 per cent plus or minus.

Description	Stock No.
0 to 500 Pounds, 5-Pound Divisions	(893409)
0 to 1000 Pounds, 10-Pound Divisions	(893410)
0 to 2500 Pounds, 50-Pound Divisions	(893411)
0 to 3500 Pounds, 50-Pound Divisions	(893412)
0 to 5000 Pounds, 50-Pound Divisions	(893413)
0 to 7500 Pounds, 50-Pound Divisions	(893414)
0 to 10000 Pounds, 100-Pound Divisions	(893415)
0 to 15000 Pounds, 125-Pound Divisions	(893416)

**HOME UTILITY ELECTRIC DRILLS**

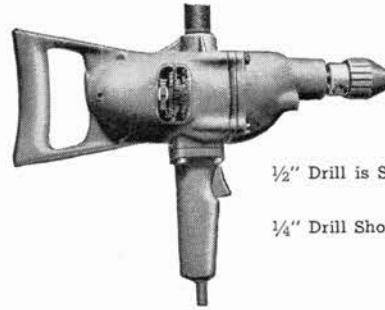

1/2" Drill is Shown Above;

1/4" Drill Shown Below at Left.

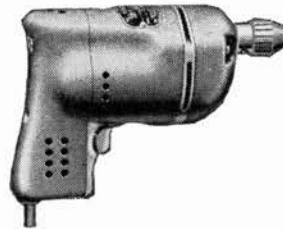

These are well built tools with ample motor, husky housings, full sized gears and bearings. Drills holes in a jiffy in metal, wood or plastics. Can also be used to drive grinding, sanding and polishing attachments and for sharpening tools. Excellent for drilling out rusted bolts and studs.

Immediately available in the two sizes shown below:

1/4" Home Utility Drill, Stock No. (894761)

1/2" Home Utility Drill, Stock No. (894762)

**DILLON BISECTORS**

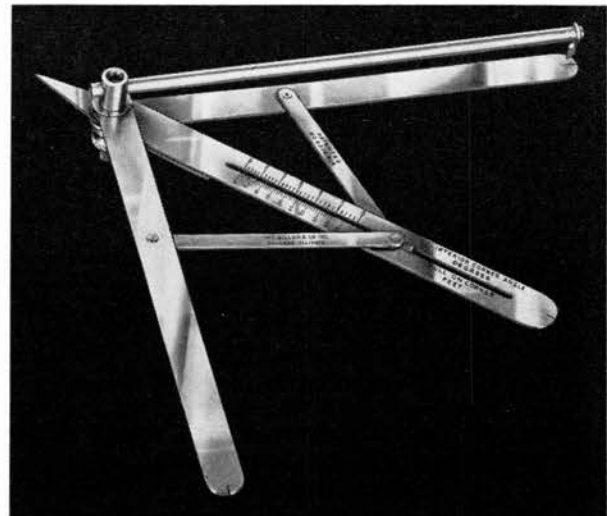

An easily operated anchor hole locator. Scientifically spots the location where an anchor pole or anchor should be placed. The accuracy with which it bisects the angles and determines the center of the lines of force takes the guesswork out of this phase of line construction.

Length, 12 1/2 inches; depth, 1 3/8 inches; and width, 7/8 inch. Complete instructions accompany each instrument.

Shipping weight, 1 pound. Stock No. (893406)

## NO. 0-6119 PREST-O-LITE LINEMEN'S OUTFITS

### Less Tank

A combination of soldering iron and open flame torch stem with a handle common to both. This compact assembly answers all requirements: soldering, brazing, splicing and similar operations, on wire, cables, transformers, switchboards, generators and lighting fixtures.

Outfit consists of:

No. O6P64 Soldering Iron.

No. A-6085 Stem and Mixer Assembly.

No. A-3321 Handle Assembly.

No. A-3881 Straight Union for Prest-O-Lite MC Tank.

No. Z-54 6 feet of 1/4-inch hose.

No. A-963 Two Hose Clamps.



Shipping weight, 3 pounds, 6 ounces. Stock No. (890882)

## NO. 0-6120 PREST-O-LITE LINEMEN'S OUTFITS

### Less Tank

For use where open flame work only will be encountered. Torch is light and convenient to handle. Its small, intense flame is ideal for general purpose work, splices in wire and cable and similar heating operations on transformers, switchboards, etc.

Outfit consists of:

No. A-6103 Torch.

No. A-3321 Handle Assembly.

No. A-3881 Straight Union for Prest-O-Lite MC Tank.

No. A-54 6 feet of 1/4-inch hose.

No. A-963 Two Hose Clamps.

Shipping weight, 2 pounds, 14 ounces. Stock No. (890889)



## STYLE MC PREST-O-LITE SMALL TANKS



Contains Prest-O-Lite Gas for the operation of Prest-O-Lite Torches. The steel tank delivers pure, dry acetylene at the turn of a valve.

Tank is completely packed with a porous filler, which is saturated with a liquid chemical, capable of absorbing many times its own volume of acetylene. The flow of gas is controlled by a key-operated valve, and can be turned on and off like city gas. A gauge at one end of the tank indicates what portion of the gas supply remains.

Prest-O-Lite Gas is freeze-proof and can be used in any kind of weather, both indoors and outdoors.

The empty tanks can be exchanged at any Prest-O-Lite Gas Exchange station for full tanks, by paying for the gas only.

Length, 13 1/2 inches. Diameter, 4 inches. Rated capacity, 10 cubic feet. Average weight, 10 pounds. Stock No. (890907)

## NO. 0-6343 PREST-O-LITE 4-IN-1 OUTFITS



Complete equipment for all open flame soldering, brazing and heating purposes. Offers in one compact unit four different flame ranges, enabling assembly of an outfit for very fine, light, medium and heavy soldering, brazing and heating operations. It's

ideal for radio soldering, sealing batteries, burning cable lugs, mechanical refrigerator repair and a wide range of new operations.

Outfit includes torch handle and stem and mixer assemblies as follows:

No. O7R05 for very fine soldering.

No. A-6086 for light soldering.

No. A-6083 for medium soldering.

No. A-6089 for heavy soldering and heating.

No. A-6058 Interchangeable open-flame stems.

Union for Prest-O-Lite B Tank and MC Tank.

No. Z-54 6 feet of 1/4-inch hose.

Waterproof carrying case.

Shipping weight, 2 pounds, 10 ounces. Stock No. (890895)

## NO. 0-6109 PREST-O-LITE 5-IN-1 OUTFITS



Torch stems in this outfit cover same range of open flame operations as the 4-in-1 outfit. Soldering copper, which distinguishes this outfit, is useful for light to medium tin work, telephone switchboard, electrical, radio and automotive repairs and similar work, particularly in confined places. Flame is entirely enclosed, eliminating possibility of burning adjacent materials. Retin-

ning of the copper is unnecessary, since flame does not come in contact with that part of the iron.

Torch stems are precision finished. Designed for work in any position. An individual mixer for each stem automatically maintains the right mixture of acetylene and air, thus insuring maximum flame intensity. Handle, common to all torches, is made of a non-heat-conducting material, which will not crack, warp or become loose and turn on the shaft.

Outfit includes torch handle and stem and mixer assemblies as follows: No. O7R05 for very fine soldering; No. A-6086 for light soldering; No. A-6083 for medium soldering; No. A-6089 for heavy soldering; No. O9R68 soldering copper; Union for Prest-O-Lite B Tank; Union for Prest-O-Lite Style MC Tank; No. Z-54 6 feet of 1/4-inch hose; wrench; and metal carrying case.

Packed in a durable metal case with snap lock and fitted with spring clips to protect parts from loss or damage. Shipping weight, 5 pounds. Stock No. (890905)

**STERLING POCKET METERS**

**Direct Current**

Useful in all kinds of battery testing, automotive ignition work, servicing radios, gas engines, motor-boats, doorbells, telephones, and in low-voltage electrical work generally. Serve as polarity indicators.

Has calibrated scale, durable, clearly marked dial, and full nickel-finished case, 2¼ inches in diameter and ⅝-inch thick. Equipped with flexible cord and spur for making connections. Packed individually, 10 to a standard package. Shipping weight per standard package, 4 pounds.

**NO. 24 AMMETERS**

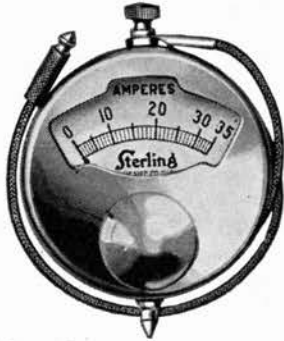

For testing No. 6 dry cells.

Scale is 0-35 amperes, 1 ampere divisions.  
Stock No. (892100)

**NO. 34 VOLTMETERS**



For 6-volt batteries, dry or storage.

Scale is 0-10 volts, 1/5-volt divisions.  
Stock No. (892101)

**NO. 44 VOLTAMMETERS**

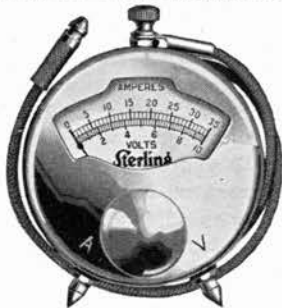

For storage batteries and dry cells.

Scale is 0-35 amperes, 1-ampere divisions; 0-10 volt scale, 1/5-volt divisions.  
Stock No. (892102)

**STEWART MIDGET DETECTO-METER**



The Stewart Midget Detecto-Meter has a multitude of uses in the plant or out on the line. Because of its light weight and small size, it is extremely handy. Can be carried in pocket or tool kit, and will take lots of abuse.

The Midget Detecto-Meter has two scales—a voltage range and a resistance range, one above the other. (See cut above.) The meter is for use only on direct current and will not operate on alternating current. When the two line cords are connected to an object

of unknown resistance, the true resistance of the object will be indicated up to a maximum of 10,000 ohms.

Top and bottom of Midget Detector-Meter are fitted with gleaming bakelite panels, and instrument uses two ordinary 1½ volt flashlight cells obtainable anywhere.

Description	Stock No.
0 to 60	(894665)
0 to 1.5	(892069)

**STEWART TEST SET**



The Stewart Test Set tells which way and how far the trouble is from the tester without opening the line or cutting a wire.

The top has been designed to hold the receiver and detector coil when they are not in use.

The receiver is equipped with a head band that makes possible the use of both hands when testing, and this head band also fits in the top.

By the use of a plug on the receiver cord and a jack built into the detector coil, it is only necessary to pull the plug out of the top of the test set and plug it into the coil to use the coil. By the use of the plug and jack only the receiver cord and the line cords are necessary on the test set.

To connect the detector coil to the wire simply push the coil against the wire and keeper will open up and the coil will slip over the wire.

The detector coil works as well on insulated wire as it does on bare wire. You do not have to cut the insulation on the wire to attach the coil.

The lamp is arranged so that it will not light on a line that is clear, but will light on a line that is in trouble. The lamp will tell whether the trouble is close to you or far away.

The talking circuit is arranged so that the test set is either a common battery test set or a local battery test set. This is a valuable feature when testing cable or where two men are working together on the same line or cable.

The circuit is also arranged so that by simply pressing the button on the set you can furnish battery to a man at the other end of a line or cable pair for test purposes.

The generator in the heavy duty test set is a standard telephone generator.

Description	Stock No.
12 Lb.	(892073)

## STEWART CABLE TESTER



Trouble that might ordinarily take hours to find can be located with the Stewart Cable Tester in only a few minutes. It locates shorts, crosses, grounds and wet spots right to the inch. This highly reliable instrument is the only one of its kind having an exploring coil which is neutral to the tone on the sheath. This feature is absolutely necessary to locate water trouble. Valuable tone test feature can be used to "tone" out cables and tag splices.

When the Stewart Cable Tester is connected to a wet wire in a cable these three fields are always set up. With the Stewart Exploring Coil held on the bottom of the cable as shown, the fields around the messenger and the armor are balanced out, and the only current that can be heard is the current on the wire, as it is the only field that is off center thus affecting one side of the coil more than the other. Stock No. (892070)

### Tester and Locator



The Cable Tester and Locator tells where a cable or pipe is buried and correct depth.

This fine instrument combines all of the outstanding features of the Cable Tester described above PLUS an uncanny ability to locate buried cable or pipe and tell the operator just how deep it is in the ground. Many times it is necessary to find old cable

placed in the ground some years ago and on which installation records have been lost. In such cases, the Stewart Cable Tester and Locator saves hours of time in probing and eliminates danger of injuring the cable. Stock No. (892071)

## VOLT-OHM-MIL-AMMETER MODEL 625-NA

The widest range tester of its type. A long mirror scale for improved reading accuracy; resistance ranges now to 40 Megohms; D.C. Voltage ranges with dual sensitivity (10,000 and 20,000 ohms per volt) provide for double the number of full-scale readings given by the average tester.

### 18 Voltage Ranges

Six D.C. Volts 0-1.25-5-25-125-500-2500 at 20,000 ohms/Volt  
Six D.C. Volts 0-2.5-10-50-250-1000-5000 at 10,000 ohms/Volt  
Six A.C. Volts 0-2.5-10-50-250-1000-5000 at 10,000 ohms/Volt

### Six Current Ranges

D.C. Microamperes 0-50 at 250 millivolts  
D.C. Milliamperes 0-1-10-100-1000 at 250 millivolts  
D.C. Amperes 0-10 at 250 millivolts

### Three Resistance Ranges

Ohms 0-2000-200,000 (12-1200 at center scale)  
Megohms 0-40 (240,000 ohms at center scale)

### Six Decibels Ranges

-30, +3.0, +15, +29, +43, +55, +69. (Reference level "O" DB at 1.73 V. on 500 ohm line.)

### Output

Condenser in series with A.C. Volt ranges.

### General Description

**MOLDED, INSULATED CASE**—Black molded 2½" x 5½" x 6" with removable black leather strap handle.

**PANEL**—Black molded with white markings.

**CONNECTORS**—Two banana jacks on front panel for V-O-MA, A, and COM., and one on left side of panel for 2500 and 5000 volts.

**LONG-SCALE INSTRUMENT**—The large 6" indicating instrument is adjusted to 50 microamperes at 250 millivolts with separate internal housing for protection of mechanism during battery replacement.

**LONG MIRROR SCALE**—5 inches long at top arc. Excellent readability. Black on white except A.C. markings which are red on white and ohms which are green on white.

**WEIGHT**—Approximately 3 pounds, complete with battery.

**BATTERY**—Self-contained. One 15V Mini-max Eveready No. 411 or equivalent, and one 1½V Eveready No. 935 or equivalent.

**LEADS**—50 inches long. Test prods with removable alligator clips at one end. Banana plugs for connecting to tester jacks at other end. Catalog No. 625-NA Stock No. (894802)



No. 625-NA



No. 666-HH

## MODEL 666-HH

A precision-manufactured marvel of compactness that provides a complete miniature laboratory for voltage, resistance and direct current analyses.

### Ranges

D.C. Volts 0-10-50-250-1000-5000 at 1,000 ohms/Volt  
A.C. Volts 0-10-50-250-1000-5000 at 1,000 ohms/Volt  
D.C. Milliamperes 0-10-100-500 at 250 Millivolts  
Ohms 0-2,000-400,000 (12-2400 at center scale)

### General Description

**MOLDED, INSULATED CASE**—Black Molded 3⅛" x 5⅞" x 2⅞".

**PANEL**—Black Molded with engraved white markings.

**CONNECTORS**—Three banana jacks at the top of the panel reduce possibility of connecting leads falling over scale or controls.

**INSTRUMENT**—3" meter, integral with panel, adjusted to 400 microamperes and 250 millivolts.

**SCALE**—2⅞" long at top arc. Black on white except A.C. markings which are red on white.

**WEIGHT**—1½ pounds complete with battery.

**BATTERY**—Self-contained plug-in. One 1½ volt Eveready No. 935 or equivalent.

**LEADS**—50 inches long. Test prods with removable alligator clips at one end. Banana plugs at the other end for connecting to tester jacks.

Catalog No. 666-HH Stock No. (894801)

**MODEL 564 WESTON VOLT-OHMMETERS**

**Type 3C**



Has a useful selection of voltage and resistance ranges.

A self-contained, 4½-volt battery provides the necessary potential for the ohmmeter ranges. Changes in battery potential are compensated for by short-circuiting the resistance pin jacks of any range and adjusting pointer to zero ohms by turning the battery adjustment knob.

Size, 4 33/64 x 3 45/64 x 2 9/16 inches. Voltage ranges; 3/30/300/600 d.c., all 1000 ohms per volt. Resistance ranges; 1000/10,000/100,000/ and 1,000,000 ohms, full scale.

Ranges are available from engraved pin jacks moulded internally with the panel. A toggle switch connects meter in circuit as a voltmeter or ohmmeter. Complete with pair of 4-foot test leads. Approximate weight, 1¾ pounds.

Type	Stock No.	Model
3C	(892087)	564
Leather Carrying Case		Stock No. (892086)

**WESTON OHMMETERS**



Designed for the service man who relies upon resistance and continuity tests in checking circuits. Type 1E scale is calibrated with a double range and resistance readings are available from 0-5000 and 0-50000 ohms; Type 1F with ranges 10 and 1000 ohms.

A 1½-volt No. 2 unit-cell battery, mounted inside the case, makes it independent of an outside source of potential.

A magnetic shunt provides convenient adjustment to compensate for variation in battery voltage. This

adjustment may be made before each series of tests, thus assuring accurate resistance readings.

Complete with battery and a long pair of test leads.

Type	Stock No.	Model
1E	(892084)	689
1F	(892085)	689

**MATTHEWS WOODPECKER TELEFAULTS**

**Type L**

This instrument will locate shorts of all kinds—damp spots, crosses, grounds, split pairs, etc. Compact, convenient, and simple to operate. Does not noise up other pairs, because of the inductive field created.



With the instrument connected, the exploring coil is moved along the cable until the point is reached where the woodpecker tapping tone cannot be heard in the earphone, indicating the exact location of fault.

The woodpecker tapping tone is very distinct and cannot be

confused with other inductive noises.

Operates on one dry cell. Maximum voltage, under 5 volts.

	Description	Wt. Lb. Each
Type L Woodpecker Telefault, Complete	.....	15
Extra Exploring Coil, Only	.....	2
Extra Receiver Only, with Cord	.....	2
	Stock No. (892075)	

**MATTHEWS TELEHEIGHTS**

**Type CW**

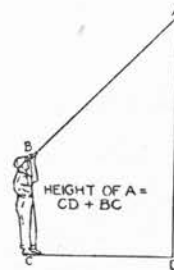

A handy, practical instrument that will save time in quickly and accurately figuring heights of poles, trees, wires, buildings, etc.

Easy to operate, no moving parts. Length, 5 inches.

Furnished with instruction sheet; and leather carrying case.

Weight, 2 ounces. Stock No. (892103)

**MODEL 4300 TELOHM**



For testing and locating line, telephone and switchboard trouble, high resistance joints, shorts, grounds and opens; also open circuits on coils of all kinds, partially shorted coils, high resistance transmitters, cut-outs in cords, contacts, etc.

Equipped with Weston O-3 volt direct reading ohmmeter with 0-10,000 ohm scale and glass protector, 2 flashlight cells, switch, cords and test clips. Mounted in a solid walnut case, 1¾x3½x 6 inches.

Weight, 1¼ pounds.

Model 4300 Stock No. (892088)

## L AND N WHEATSTONE FAULT LOCATION BRIDGE TEST SETS

### No. 5300—Type S



For ordinary resistance testing and for locating faults in communication circuits.

Ratio dial has multiplying values of 0.001, 0.01, 0.1, 1, 10, 100 and 1000 for resistance measurements and for Varley Loop tests; also settings for M1000, M100 and M10 for ratios in Murray Loop tests. Rheostat

has 4 decades  $9(1+10+100+1000)$  ohms. Limit of error in ratio resistors  $\pm 0.05\%$ ; In rheostat arm: resistance change from zero settings of dials equals dial settings  $\pm (0.1$  per cent  $+ 0.01$  ohm). Includes pointer galvanometer of 1-megohm sensitivity, 4.5 volt battery and keys for galvanometer and battery.

Furnished in oak case,  $8\frac{7}{8} \times 7\frac{3}{8} \times 5\frac{5}{8}$  inches, with hinged lid and carrying strap.

Weight, 8 pounds.

Cat. No.	Stock No.	Description
5300	(892099)	Type S
5431	(892098)	Leather Case

### No. 5430-A—Type U



A portable Wheatstone bridge especially adapted for locating faults in communication circuits.

Ratio dial has multiplying values of  $1/1000$ ,  $1/100$ ,  $1/10$ ,  $1/9$ ,  $1/4$ ,  $1/1$ ,  $10/1$  and  $100/1$  for resistance measurements and for Varley Loop tests; also settings of M1000, M100 and M10 for ratios in Murray Loop tests.

Rheostat has 4 decades,  $10(1+10+100)+9 \times 1000$  ohms  $+ \infty$ . Limit of error in ratio resistors  $\pm 0.05\%$ ; In rheostat arm: resistance change from zero settings of dials equals dial settings  $\pm (0.1$  per cent  $+ 0.01$  ohm). Includes pointer galvanometer of 1-megohm sensitivity, 4.5 volt battery and keys for galvanometer and battery. Hilborn Loop test can be made, using internal galvanometer.

Furnished in oak case,  $8\frac{7}{8} \times 7\frac{3}{8} \times 5\frac{5}{8}$  inches, with metal protecting corners, removable lid and carrying strap.

Weight, 8 pounds.

Cat. No.	Stock No.	Description
5430-A	(892097)	Type U
5431	(892098)	Leather Case

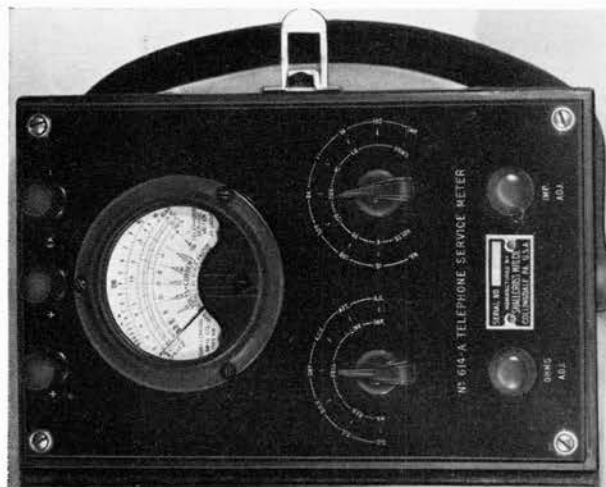

### NO. 614-A SHALLCROSS TELEPHONE SERVICE METERS

Designed to provide facilities for the telephone man in making the wide range of electrical measurements that are encountered in the telephone field.

Particularly useful for tests of subscriber set output, dry cells, transmitter current, receiver resistance, capacity of condensers, ringer impedance, magneto, output, and magneto impedance; central office commercial supply voltage, ringing machine voltage, battery charging current, etc.

Ranges: Accuracy for DC.  $\pm 2\%$ ; for A.C.  $\pm 5\%$

Voltage: D.C. 0-6-30-150-300 Volts

A.C. 0-6-30-150-300 Volts

Current: D.C. 0-15-150-300 Milliamps. 0-6 Amps

Resistance: D.C. 0-500-50,000 Ohms

Impedance: A.C. 25-3,000,000 Ohms

Inductance: A.C. 1-100-1,000-10,000 Hen.

Capacitance: A.C. 0.001-0.1-1-10 Mfd.

Power Level: A.C. -6, 0, +9 db.

Artificial Load 600 Ohms for 6-30 V. A.C.

Catalog No. 614-A Stock No. (894816)

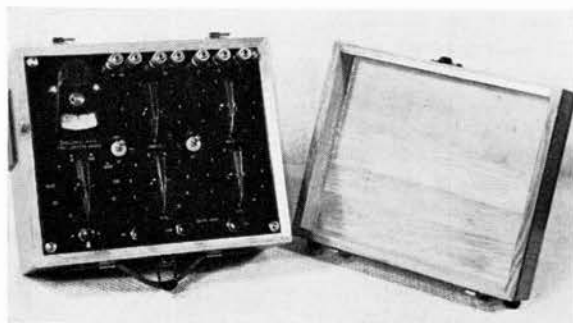

### SHALLCROSS CABLE FAULT LOCATION BRIDGE

A portable instrument having a variable ratio arm arranged for the Murray and Varley Loop tests for locating faults, grounds, and crosses.

Steps of multiplier switch for use as Wheatstone Bridge:

$x0.001-x0.01-x0.1-x1-x10-x100-x1,000$  Ohms

and for Murray test:

$x1-x10-x100-x1,000$  M

Rheostat arm: 11,110 ohms variable in steps of 1 ohm

Range: 0.1-11,110,000 Ohms

Provision made for using bridge in Varley & Murray tests

Catalog No. 629 Stock No. (894817)

**NO. 695 SHALLCROSS CURRENT FLOW TEST SETS**



Provides a convenient and rapid means for testing the flow of current through relays and other apparatus commonly found in telephone and telegraph equipment.

Range: Accuracy  $\pm 2\%$  of full scale value  
 Current: D.C. 0-15-75-150 Milliamps  
 Voltage: D.C. 0-7.5-15-75 Volts  
 Variable resistors for setting of relay current  
 3 x 5,000 ohms continuously adjustable.

Catalog No. 695 Stock No. (892096)

**NO. 692 SHALLCROSS TRANSMISSION TEST SETS**



In this instrument are combined:

1. Tone Generator, 1,000 cycles, Part No. 691-A 1,000 cycles/second. Vacuum tube oscillator operating from 110-115-120 V, A.C. or D.C. Output variable from 0-18 db.
2. Transtester Part No. 690, Decibel Meter range -10, 0, +6 db, 600 ohms.
3. Attenuation pads, Part No. 355, variable from 0 to 35 db in 5 db steps.

Catalog No. 692 Stock No. (892091)

**SHALLCROSS TRANSMISSION TEST EQUIPMENT**

Developed to provide a simple, economical and modern method of measuring transmission losses.

**No. 691-A**

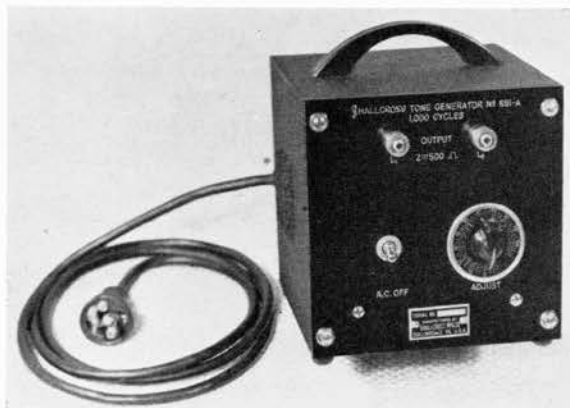

Has 1000 cycle generator. Total power, 18 db at 600 ohm impedance.

In metal case.

Catalog No. 691-A Stock No. (892092)

**No. 355**

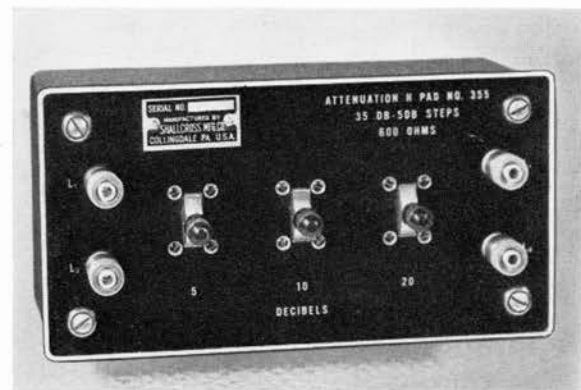

Attenuation H pad. Total of 35 decibels, in 5 decibel steps, 600 ohms impedance. In metal case.

Catalog No. 355 Stock No. (892093)

**No. 690**

Decibel meter calibrated minus (-) 10 decibels, to plus (+) 6 decibels. Zero level, 1 milliwatt at 600 ohms impedance.

In oak carrying case.

Catalog No. 690 Stock No. (892094)





**STROMBERG-CARLSON**

# Chairs, Booths, Pay Stations



**Comfortable, scientifically constructed Sturgis Posture Chairs;  
handsome, acoustic telephone booths in either wood or metal;  
Pay Stations adapted to any line for that extra income.**

CONTENTS  
SECTION U

**CHAIRS, BOOTHS, PAY STATIONS**

---

	Page
Posture Chairs .....	3u
Folding Door Telephone Booths .....	5u
Wall Type Telephone Booths .....	6u
Attachment Type Pay Stations .....	6u
Pay Station Signs .....	6u
Self-Contained Pay Stations .....	7u
Pay Station Accessories .....	8u

---

STURGIS POSTURE CHAIRS



No. 635 FF

These chairs are designed and built by chair specialists to give day-long comfort. They are ideal for telephone operators and any others whose work requires a high base chair with firm but flexible back.

Sturgis chairs are made of steel for strength and long life, welded for permanence and stability. All surfaces are smooth; all corners are rounded; no torn clothing from splinters. The finest upholstery and cushioning materials are built into the comfortable seats and back rest. The steel parts are "Bonderized" for permanence of enamel. Warm enamel colors for beauty. (Enamel infra-red baked in new, modern ovens.)

The High Master No. 637 FF

This chair has the same base as the No. 635. The back rest has a somewhat different shape. The seat is 13" x 16 3/4" and a full 3" thick, consisting of coil springs topped with high quality soft foam rubber and upholstered. Four bolts attach the seat spider to the swivel.

Seat Adjustment	Genuine Leather Stock No.	Artificial Leather Stock No.
18" to 22"	(894588)	(894594)
20" to 24"	(894589)	(894595)
22" to 26"	(894590)	(894596)
24" to 28"	(894591)	(894597)
26" to 30"	(894592)	(894598)
28" to 32"	(894593)	(894599)

The High Standard No. 635 FF

Backrest 13" x 7 1/4" x 1 1/4" thick made from layers of felt, ncraft, cotton and upholstered. This can be furnished in Follow Flex or Firm models.

Hand adjusting knob for setting back rest in proper position. Back support and legs of 1" steel tubing. Seat 17" x 15" x 1 1/4" thick made from curled hair and upholstered. Attached to seat by four bolts. Thumb screw for tightening when proper seat height is attained.

All joints are arc-welded and polished smooth. Foot ring of 1 1/16" tubing placed from 5" to 13" from the floor.

Stainless steel spring type gliders on feet. Made in seat height adjustments as follows:

Seat Adjustment	Genuine Leather Stock No.	Artificial Leather Stock No.
18" to 22"	(894576)	(894582)
20" to 24"	(894577)	(894583)
22" to 26"	(894578)	(894584)
24" to 28"	(894579)	(894585)
26" to 30"	(894580)	(894586)
28" to 32"	(894581)	(894587)



No. 637 FF

## STURGIS CHAIRS (Cont.)

### No. 622 FF Operator's Chair

Similar to the No. 635 FF except for seat height and no foot ring.

For use with those switchboards whose key-shelf is low enough to permit the operator to rest her feet on the floor. Also widely used by stenographers and office workers at an ordinary desk. Made in one size only.

Seat Adjustment	Genuine Leather Stock No.	Artificial Leather Stock No.
17" to 21"	(894600)	(894601)



No. 622 FF

### No. 624 FF Operator's Chair

For the same purpose as the No. 622FF, but with back and seat similar to the No. 637FF. Seat 13" x 16 3/4" and a full 3" thick, consisting of coil springs topped with high quality soft foam rubber and upholstered.

Seat Adjustment	Genuine Leather Stock No.	Artificial Leather Stock No.
17" to 21"	(894602)	(894603)

### No. 648 FF Supervisor's Chair

A really high chair designed especially for the supervisor who must be able to see over the heads of the operators. Features are:

Wide base legs for safety and that secure feeling.

Sturdy construction and extra bracing for long life.

Large solid foot rest and step.

Foot ring all the way around permanently welded to the legs.

Large tablet arm of wood stained to match the leather on the right hand side.

Upholstered arm rest on the left side.

Soft seat and back rest with the firm-flex feature.

Seat Adjustment	Genuine Leather Stock No.	Artificial Leather Stock No.
36" to 40"	(894604)	(894605)



No. 648 FF

Casters are available for the No. 622 and No. 624 Chairs on special order. Chairs come with a brown enamel finish and matching brown upholstery, in either genuine leather or high grade imitation leather. Standard repair parts and accessories are available on request.

**CHURCHILL TELEPHONE BOOTHS**

**With Folding Door**

**No. 100**

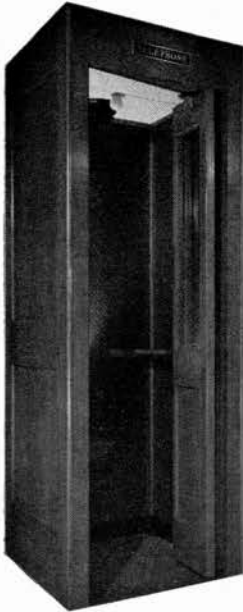

A self-contained booth designed for single or multiple installations. It effects a pleasing appearance from all angles.

Furnished without a floor. Standard equipment includes: Automatic door switch for lights and electric ventilator, silent electric ventilator, complete automatic lighting equipment, complete metal lining. Acoustically designed.

Dimensions: Height, 84½ inches; width, 30½ inches; depth, 30½ inches.

Shipped knocked down and crated.

Seats obtainable at extra cost.

**With Glass in Door Only**

Cat. No.	Stock No.	Description
100-A	(893419)	Of Oak, Light or Medium Oak Finish with Soft Wood Back.
100-B	(893420)	Of Birch, Light or Medium Mahogany finish with soft Wood Back.

**ACOUSTIC STEEL TELEPHONE BOOTH**

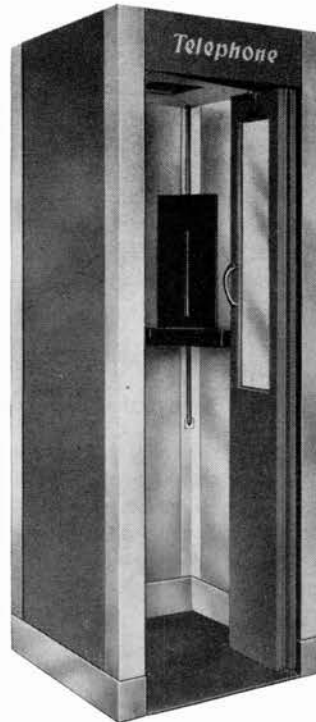

Can be installed anywhere in single or multiple units. Sound-insulated, fire-proof, wearproof, practically indestructible and may be obtained in several colors.

Door is equal-leaf type and operates smoothly and quietly in a stainless steel track. When door is open it does not extend beyond the face of booth.

The specially designed light throws maximum illumination on telephone instrument. Adequate ventilation is provided by the installation of a compact ventilating unit located between ceiling and roof. Has adjustable shelf and telephone instrument back-board.

A rigid steel seat can be provided which is readily installed or removed as required without drilling holes in floor or walls of booth.

The acoustic booth can be supplied with linings, ceiling, corners and base of stainless steel or Monel. Also available with plastic panels and ceiling.

Floor of booth is covered with rubber or linoleum. Height of floor of booth is only ½ inch above floor of room.

Outside booth dimensions: 30 inches wide, 30 inches deep and 83¾ inches high. Stock No (893433)

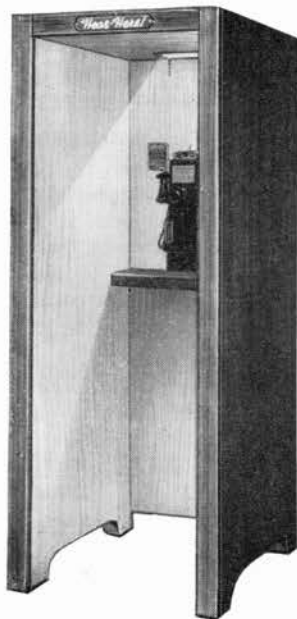

**MODEL 210**

Burgess Model 210 Acoustic Booth is ideal for stores, offices, hotels and other places where attractive appearance is important. Plywood construction, with rich walnut stain finish. Outside dimensions: 30 in. wide, 79½ in. high, 38 in. deep. Inside dimensions: 24 in. wide, 76½ in. high, 35 in. deep. Shelf: 24 in. by 8¼ in. Net weight 200 pounds. Shipping weight 225 pounds.

Stock No. (894679)

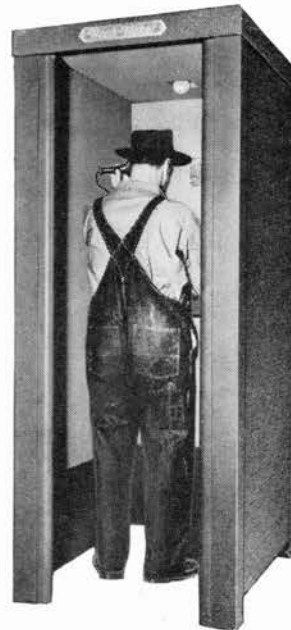

**MODEL 211**

Burgess Model 211 Acoustic Booth of heavy-duty all-steel construction, for use in power stations, factories, or other places requiring sturdy construction. Durable black wrinkle finish. Outside dimensions: 31 in. wide, 79¼ in. high, 38½ in. deep. Inside dimensions: 24 in. wide, 76¼ in. high, 35 in. deep. Shelf: 24 in. by 8¼ in. Net weight 350 pounds. Shipping weight 410 pounds.

Stock No. (894680)

## MODEL 601

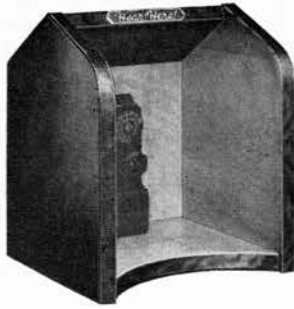

Burgess "Scout" Model 601 Acousti-Booth is ideal for busy public places where space is limited. Reinforced plywood construction with rich walnut stain exterior finish. Outside dimensions: 28 in. wide, 32 in. high, 26 in. deep. Shelf: 23½ in. wide by 17 in. deep. Net weight 60 pounds. Shipping weight 80 pounds.

Stock No. (894677)

## MODEL 602



Burgess "Scout" Model 602, similar to Model 601, but of rigid all-steel construction. Heavy-gauge perforated steel sheets protect the acoustic material. Durable black wrinkle exterior finish. Outside dimensions: 28 in. wide, 32 in. high, 26 in. deep. Shelf: 24 in. wide by 17 in. deep. Net weight 85 pounds. Shipping weight 120 pounds.

Stock No. (894678)

## POST PAYMENT ATTACHMENT TYPE PAY STATIONS

### Non-Electrical — For Local or Central Battery Service

The operation of these pay stations is accomplished without the aid of moving parts or electrical connections, the signals being produced by the coins striking gongs or chimes, the sound of which is transmitted to the central office operator through the transmitter of the telephone at which the pay station is located. In view of the simplicity and reliability of these pay stations, their maintenance cost is extremely low.

In the case of handset type pay stations, the signals are picked up by a special signal transmitter mounted within the box. These pay stations cannot be used for pre-payment service, as the coin is not under the control of the central office operator.

Coin Collectors are complete with locks but less any telephone parts.

When specified, any of the pay stations requiring Transmitter, Receiver, Cords or Dials will be equipped with these parts at regular catalogue prices plus a service charge.

## NO. 11-J UNIVERSAL HANDSET TYPE



This pay station is similar to the No. 11, but it is arranged for use with a wall type or desk type handset telephone set. The universal mounting plate is arranged for either wall or shelf mounting and a signal transmitter is mounted within the box to pick up the coin signals. It is not necessary to mechanically connect the pay station to the telephone set, but the signal transmitter must be cut into the handset transmitter circuit. A 2-conductor cord is required for this purpose. The No. LD-72 signal transmitter is included with the pay station as standard equipment.

Dimensions: 9¾ inches high, 4⅞ inches

wide, 3⅝ inches deep.

Approximate shipping weight, 16 pounds.

Catalog No. 11-J

Stock No. (893479)

## NO. 11 THREE-SLOT SIDE MOUNTING



This popular station is designed to attach to any wall type telephone set in present use. It is connected to the telephone by means of a mounting plate, which is included with the station.

Dimensions: 9 inches high, 4½ inches wide, 3 inches deep.

Approximate shipping weight, 16 pounds.

Catalog No. 11

Stock No. (893478)

## INDEPENDENT PAY STATION TELEPHONE SIGNS

These signs are unlike the lithographed steel signs.

The enamel is fused into the steel (18 gage) with a blast furnace in 1500° heat. Guaranteed never to fade or tarnish from effects of the weather.

In colors red, white, and blue.



No. 1

List No.  
1161  
1163

Stock No.  
(893506)  
(893507)

Trade No.  
1  
2

Size Inches  
17x18  
8x18



No. 2

**POST-PAYMENT SELF-CONTAINED  
TYPE PAY STATIONS**

**No. 23-D Three-Slot Compact Type**



This station is compact and neat in appearance.

It includes complete mounting for the transmitter and also the switch-hook and hook-switch springs, and dispenses entirely with the regular telephone set. All that is required is the usual bell box, transmitter, and receiver. The universal mounting plate on this station allows for either wall or shelf mounting.

The money drawer is of extra large capacity.

Dimensions: 10½ inches high, 6 inches wide, and 4¼ inches deep.

The transmitter, receiver and cord are not included with the pay station. Please specify the type and make of ringer box to be used so the proper circuit arrangement will be supplied.

Approximate shipping weight, 20 pounds.

Catalog No. 23-D Stock No. (893483)

**No. 23-J Compact Handset Type**



This station is similar to the No. 23-D, but it is arranged for a handset. It includes the switchhook and hook switch springs and requires only the usual bell box and handset with associated cords.

The universal mounting plate on this station allows for either shelf or wall mounting.

The No. LD-72 signal transmitter is included as part of the standard equipment.

Dimensions: 10½ inches high, 6 inches wide, 4¼ inches deep.

Approximate shipping weight, 20 pounds.

In ordering state the type and make of handset and ringer box to be used.

Catalog No. 23-J Stock No. (893484)

**PREPAY AND CONVERTIBLE  
POSTPAY TYPE PAY STATIONS**

The Standard Type Pay Stations can be furnished for pre-payment or post-payment service on manual or machine switching exchanges.

They are arranged for wall mounting, but may be mounted in a corner by means of a No. 153-A bracket, or on a shelf by means of a No. 139-A backboard.

**PREPAY TYPES (Cont.)**

These stations are sturdily constructed of heavy, pressed steel and the cash compartment door is hardened to prevent burglary. They are furnished in black japan with chromium-plated trimmings.

When used for pre-payment service, special central office equipment is required to switch 110-volt direct current on to the line to operate the coin collecting and refunding magnet.

**NO. 150-G PRE-PAYMENT TYPE**



This machine is designed for manual or dial service in conjunction with a desk set box with a three winding induction coil for anti-side tone service, or it may be used with a two winding induction coil for side tone service.

Dimensions: 18¼ inches high, 7 inches wide and 6 inches deep.

Approximate shipping weight, 32 pounds.

The transmitter, receiver and dial are not included with the pay station. In ordering, for manual service, specify the following accessories: 50-C apparatus blank, 10-L lock and coin receptacle; for dial service, specify No. 1-B card holder, No. 10-L lock and coin receptacle.

Catalog No. 150-G

Stock No. (893485)

**NO. 150-H PRE-PAYMENT TYPE**

This differs from the No. 150-G pay station only in the quarter coin channel which will accept Canadian coins

Catalog No. 150-H

Stock No. (893486)

**NO. 150-GJ PRE-PAYMENT TYPE**



The letter J in the code number of a pay station signifies that a handset is used. The No. 150-GJ is similar to the No. 150-G except that it is arranged for a handset and provisions are made for a signal transmitter mounted within the box. The handset and cord, extended dial number plate and mounting are not furnished with this station. For dial operation, the order should specify for dial service so that the apparatus blank will be mounted in the proper place.

The Nos. 150-HJ, 150 KJ and 150-LJ are likewise arranged for the handset and bear a like relationship to the Nos. 150-H, 150-K and 150-L.

Catalog No. 150-GJ

Stock No. (893489)

## PREPAY AND CONVERTIBLE TYPES (Cont.)

### No. 150-K Post-Payment Type

This pay station is convertible to a No. 150-G pre-payment pay station by adding a coin magnet.

Dimensions: 18¼ inches high, 7 inches wide, 6 inches deep.

Approximate shipping weight, 30 pounds.

The transmitter and receiver are not included with the pay station.

Cat. No. 150K Stock No. (893487)



### No. 150-L

This pay station is similarly convertible to a No. 150-H pre-payment pay station.

Catalog No. 150-L

Stock No. (893488)

## NO. 34-A-8 PRE-PAYMENT MACHINE SWITCHING TYPE

This station has an anti-side tone circuit and requires the use of a ringer box with a three winding induction coil. An extended dial number plate mounting arranged for the A. E. Co. dial is furnished as standard equipment. The transmitter, receiver, dial and extended dial number plate are not included with the pay station.

Approximate shipping weight, 32 pounds.

Catalog No. 34-A-8

Stock No. (893493)



No. 34-A-8



No. 34-A-9

## NO. 34-A-9 MACHINE SWITCHING TYPE

Similar to No. 34-A-8, but designed to accommodate the handset. The handset, dial and the extended dial number plate are not included with the pay station.

Approximate shipping weight, 32 lbs.

Catalog No. 34-A-9

Stock No. (893494)

## No. 34-A-10 Post-Payment Dial Service Type

This pay station is a special type which will permit the subscriber to dial the desired party without depositing a coin, but requires a coin to be deposited after the called party has responded before the conversation can be carried on. It can be used only with central office equipment of the dial switching type which reverses the battery supply to the calling party's loop when the called party answers. The circuit is anti-side tone and requires the use of a special ringer box with a three winding induction coil and an extra condenser. An extended dial number plate mounting arranged for the A. E. Co. dial is included as standard equipment. The transmitter, receiver, dial and extended dial number plate are not included with pay station unless the apparatus is ordered equipped. Weight 32 pounds.

Catalog No. 34-A-10

Stock No. (893495)



No. 34-A-10



No. 34-A-11

## No. 34-A-11 Post-Payment Machine Switching Type

This pay station is similar to No. 34-A-10, but is designed to accommodate the handset.

Catalog No. 34-A-11

Stock No. (893496)

## ACCESSORIES FOR PAY STATIONS

### No. 10-L Cash Compartment Door Locks

This lock is a combination of pin tumbler and flat lever construction, giving double security.

Made with all different combination.

Catalog No. 10-L Stock No. (893497)



ACCESSORIES FOR PAY STATIONS

**No. 50-C Apparatus Blank Assembly**

This assembly is used to cover the dial opening and mount the direction card on manual type pay stations and to mount the direction card on the hand-set types.

Catalog No. 50-C Stock No. (893498)



**No. 1-B Card Holder Assembly**

The No. 1-B card holder assembly is used to mount the direction card on those models having no space for the card on the front of the pay station.

Catalog No. 1-B Stock No. (893499)

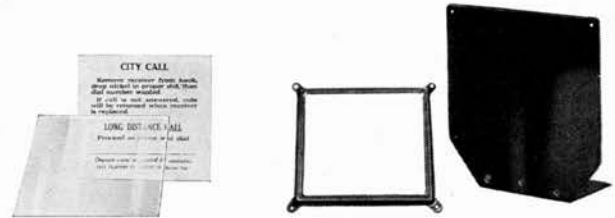

**No. 2-A Coin Receptacles**

This is a large capacity non-locking coin tray for the collection of coins in Standard Pay Stations.

Catalog No. 2-A Stock No. (893500)

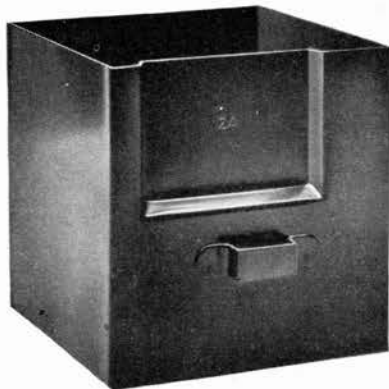

**No. 6001 Self-Locking Coin Receptacles**

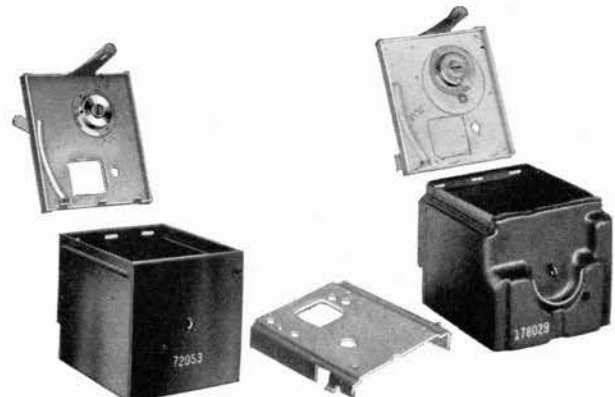

No. 6001-A

No. 6001-B

**No. 139-A Shelf Bracket**

This bracket is used to mount any of the Standard Pay Stations on a horizontal surface such as a shelf or counter.

Approximate shipping weight, 15 lbs.



No. 139-A

**No. 153-A Corner Bracket**

This bracket is used to mount any of the Standard Pay Stations in the corner of a telephone booth or other constricted space.

Approx. ship. wt., 17 pounds.



No. 153-A

Cat. No. Stock No.  
139-A (893503)

Description  
Shelf Bracket, Includes Screws

153-A (893504)

Corner Bracket, includes Screws

With this receptacle, the coin opening in the cover is automatically locked when the receptacle is removed from the pay station. The collector does not handle any money but merely replaces the full receptacle with an empty one, which has had the cover sealed in place by the Company office.

No. 6001-A is the plain type of receptacle.

No. 6001-B is of the latest design. The tray is expanded at every possible point to obtain the maximum coin capacity. A wire handle permits easy removal from the pay station.

Catalog No. 6001-A Stock No. (893501)

Catalog No. 6001-B Stock No. (893502)

**NO. LD-72 SIGNAL TRANSMITTERS**

This special signal transmitter incorporates a shunting resistor and a dampening spring which makes it suitable for use on the J type pay stations for picking up the coin signals. This transmitter is included as standard equipment on the attachment type handset paystations, Nos. 11-J, 14-J and 23-J, but it must be specified for standard types.

Catalog No. LD-72 Stock No. (893505)



**STROMBERG-CARLSON**

# Carrier Equipment

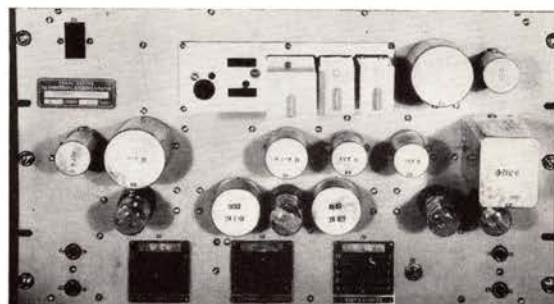
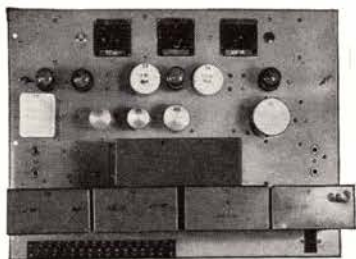

**The Adler System of Carrier Equipment increases toll or trunk line capacity at a low initial cost. Two decades of service.**

CONTENTS  
SECTION V

**CARRIER EQUIPMENT**

---

	Page
Adler Carrier Systems .....	3v
Type SD System .....	4v
Carrier Frequency Chart .....	5v
Voice Frequency Repeaters (or Amplifiers) .....	5v
Auxiliary Equipment .....	6v

---

## ADLER CARRIER SYSTEM

The Adler Carrier System, now being offered to the trade by Stromberg-Carlson Co., represents more than 18 years' experience in the design, manufacture, and operation of carrier telephone equipment particularly suited to the needs of Independent telephone companies, railroads, pipe lines, and other private wire interests. Since this line of equipment has been developed particularly to meet a wide variety of operating conditions in the Independent field, it features flexibility of circuit layout and ease of installation and maintenance and does not require highly trained maintenance personnel always in attendance.

### Noteworthy Features

**CATHODE-FOLLOWER AMPLIFIERS** throughout the SD system. This insures excellent impedance matching and flat frequency response throughout all carrier bands.

**UNIVERSALLY WIRED** for either ring-down or dial and full supervision circuits. No extra panel needed in changing from one type of operation to the other or in using a combination of both.

**MOLYPERM FILTERS** made of selected high grade materials with toroidal dust core.

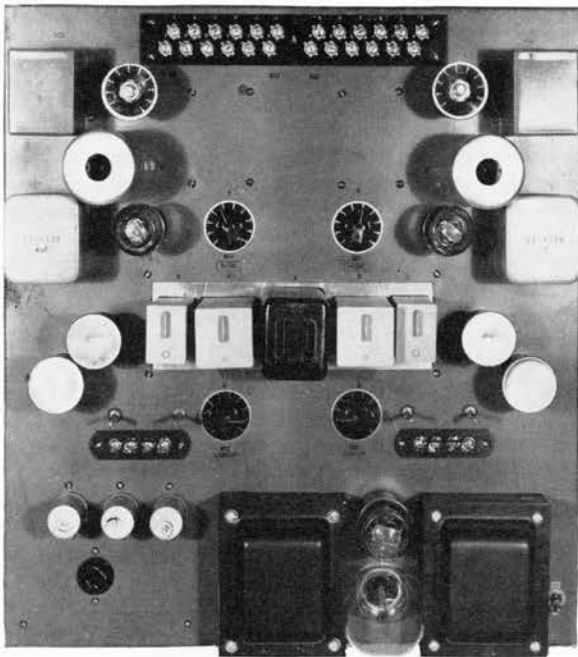

A Typical Adler Carrier Repeater Unit Rack  
Mounted for Interchangeability

The principle purpose of a carrier telephone system is to provide one or more additional independent two-way talking circuits, or "channels," over an existing pair of wires which already serves as a medium for transmitting an ordinary voice-frequency conversation. Each carrier system usually consists of two "terminals," one for each end of the circuit; if the transmission loss between terminals is sufficiently high, one or more carrier-frequency amplifiers, or "repeaters," may be required at suitably spaced intermediate points.

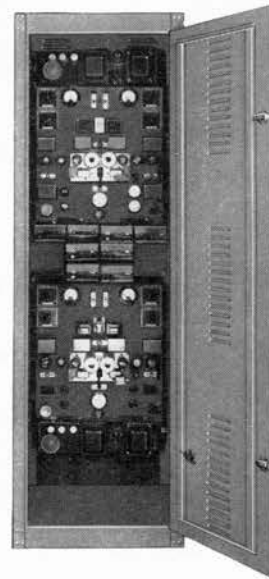

A Typical Adler Carrier SC-2A Installation  
Housed in Steel Cabinet

Adler carrier terminals which provide one, two, or three carrier channels are available. Each terminal is complete in itself and contains all components necessary for insuring the independence of each carrier channel and the voice-frequency circuit. Similarly, each carrier repeater is a complete unit which provides for the amplification of the carrier frequency signals which approach the repeater point from either direction. The voice-frequency channel can be terminated at the repeater point, be by-passed around the carrier repeater, or be amplified by a separate voice-frequency repeater as individual circumstances may require.

### TYPES OF CARRIER EQUIPMENT

Two types of carrier equipment are manufactured and offered to the independent telephone industry as standard models. The SD systems are commonly spoken of as short-haul carriers. Relatively inexpensive, these systems are designed to operate and "prove in" on lines ranging up to approximately 150 miles of No. 9 copper open wire circuit. Distances will vary up or down according to local conditions.

The SC systems, or long-haul carrier, are designed to operate over long toll circuits where the very considerable savings in line equipment will justify its installation.

Both the SD and SC types are available in one, two or three channel systems. Because of their unit construction they are immediately ready for the addition of individual channels as traffic warrants, without disturbing the original equipment. Moreover, it is possible to set up a through carrier channel over a long circuit which is broken at one or more intermediate switchboards. Carrier channels can also be arranged to drop off at any intermediate point on a long physical circuit.

All Adler carriers furnish a talking frequency band from 200 to 2800 or 3000 cycles.

## TYPE SD SYSTEM

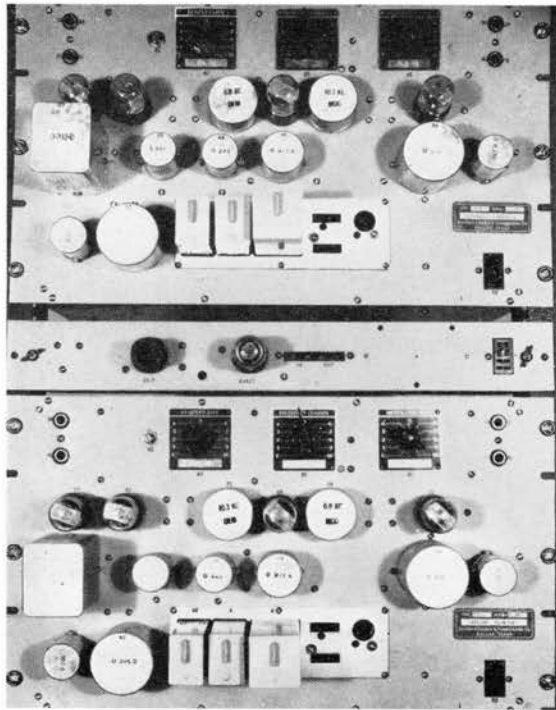

Page shows three views of an SD System

The Type SD carrier telephone systems are designed to provide facilities for superimposing one, two or three additional, independent and simultaneous two-way talking circuits over an existing pair of wires. Facilities are provided for either ring-down operation or dialing and supervision and these operations are accomplished within the limits of such individual carrier channel. As a result, the remaining carrier spectrum is free of signalling channels and may be utilized for additional carrier channels. The equipment is generally used as a permanent plant installation but may also be employed with high efficiency for temporary or emergency circuits. Without the use of repeaters, the Type SD systems will find their widest application on open-wire circuits varying in length from 25 miles to 150 miles or on a circuit which has not more than 15 db attenuation at its carrier frequency. This range may be extended by use of available carrier repeaters, or by use of the extension amplifier, D-234. Range of this carrier equipment in miles is of course dependent on variables such as the characteristics of open-wire line, the amount of intermediate cable, the number of side-lines and bridged stations, and other similar features that would affect operation of the lines at carrier frequencies.

The Type SD carrier systems utilize copper-oxide modulators and demodulators, heater-type vacuum tubes and high quality filters made possible by the use of improved magnetic alloys. The method of transmission employed is of the single side-band, carrier suppressed type. The copper-oxide bridge connected rectifier employed for modulators and demodulators provides the advantage of long and trouble-free life, minimum power consumption, improved balance and stable operation.

The Type SD systems have been designed primarily for use on relatively short lines, and therefore, no wire-circuit equalization networks are provided. For the same reason, automatic regulation of the circuit net loss is not provided. However, manually adjustable attenuators are provided to compensate for variations in circuit losses due to varying weather conditions.

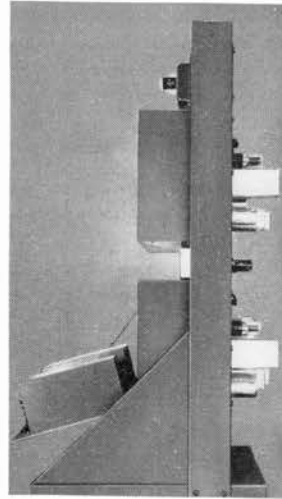

The Type SD terminals and repeaters are designed to operate from the commercial 110-120 volt, 50-60 cycle supply, and if an emergency source of power is required to be available, dynamos and automatic change-over equipment can be supplied.

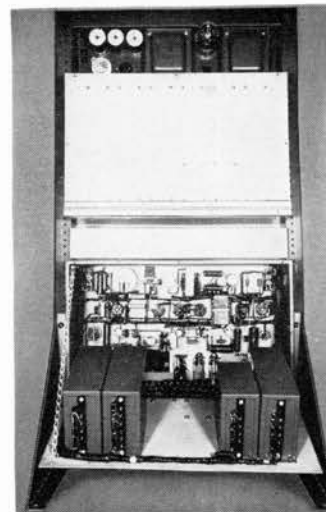

The carrier frequencies employed for such direction of transmission are shown above. The carrier frequencies are generated locally at each terminal and by means of careful modulator balance and suitable filters, the carriers and unwanted sidebands are suppressed, the desired intelligence being transmitted by means of a single side-band. Selected frequencies for each direction of transmission are in accordance with the accepted practice.

**Carrier Frequency Chart**

Type of Terminal	Standing Wave Frequencies Used (Using lower side band transmission)
SD-1 Single Channel or "First Story"	6.8 KC East or North bound 10.3 KC West or South bound
SD-2 "Second Story" Channel	20.8 KC East or North bound 16.8 KC West or South bound
SD-3AS "Third Story" Channel	25.7 KC East or North bound 29.8 KC West or South bound
SC-1A Single Channel or "First Story"	7 KC East or North bound 10.5 KC West or South bound
SC-2A "Second Story" Channel in conjunction with SC-1A	21 KC East or North bound 14 KC West or South bound
<b>(Channel 1)</b>	
SC-3A Three Channel System	24.4 KC East or North bound 15.9 KC West or South bound
<b>(Channel 2)</b>	
	20.7 KC East or North bound 12.4 KC West or South bound
<b>(Channel 3)</b>	
	28.5 KC East or North bound 9.3 KC West or South bound

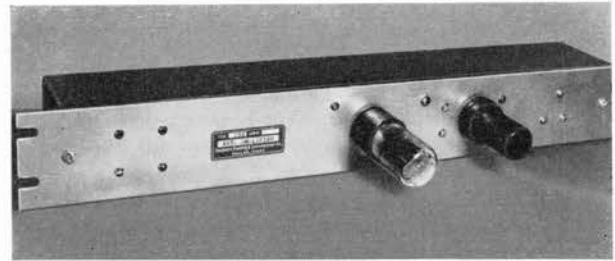

D-234 Extension Amplifier

**Voice Frequency Repeaters**

Three types of voice repeaters are manufactured:

- RR-2 This repeats voice only; low frequency signalling by passed.
- RR-3 This repeats voice and low frequency signalling.
- RR-4 This repeats low frequency signalling only.

**RR-2 AND RR-3 AMPLIFIERS**

The amplifiers are operated entirely from 110-120 volt, 50-60 cycle power, including plate-current, filament or "heater"-current and the operation of relays. They may also be operated from 110 or 220 volt D.C. power in conjunction with any of several makes of D.C.-A.C. convertors. Battery operation, if necessary, can be obtained from 6-volt storage battery in combination with dry "B" battery or 6-volt to 150-volt inverter.

No auxiliary "networks" are required. The amplifier is equipped on both ends with variable impedance controls containing resistance, capacity and inductance elements.

On Model RR-2, the low-frequency ringing currents are "by-passed" around the amplifier at a loss of approximately 2 d.b. for frequencies of 20 cycles or lower. Frequencies above 100 cycles are effectively barred through this by-pass. This method eliminates all ringing relays and associated wiring. On Model RR-3, the ringing current is repeated instead of by-passed. This is often necessary on long-haul circuits where satisfactory signals cannot be obtained between the distance ends. This model requires a local source of ringing-current at the repeater.

**Mounting of Amplifiers**

The complete amplifier is built on a unit-type metal chassis 21" wide and 19" high. It may be mounted by any of the following methods:

- On any standard floor rack having a clearance of 17½" to 18" between uprights.
- On "U" brackets supported from wall.
- On "L" brackets fastened to shelf, desk or table.

In a rectangular box or frame for portable service, equipped with front and rear doors or removable panels.

The RR-2 and RR-3 Repeater is of the "universal" type, i.e. it is adapted for through-line, cord-circuit or terminal service without internal change. This flexibility is obtained by means of minor changes in connections at the terminal strip mounted on rear of the repeater.

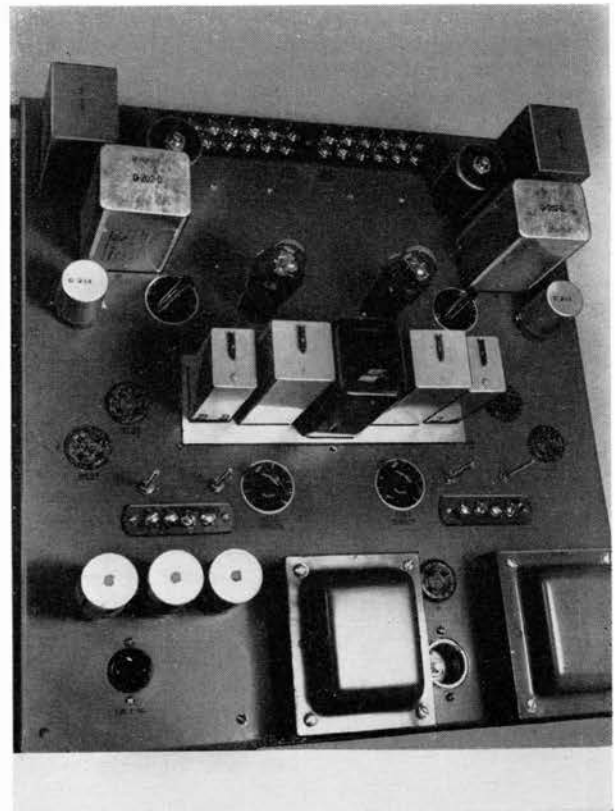

RR-3 Voice Repeater or Amplifier  
Showing the unit type design for easy installation at the point of use in either rack or cabinet.

## AUXILIARY LINE EQUIPMENT FOR ADLER CARRIER SYSTEMS

To obtain the best operation of a carrier system over any given line it may be necessary to install one or more auxiliary devices and by so doing properly "carrier-equip" the line. Whether or not such devices are necessary in a particular case can be determined only by making a study of the circuit to be used as the carrier transmitting medium. The principal purpose of these devices is to improve, at carrier frequencies the efficiency of the carrier transmission. At the same time, the quality of the voice-frequency transmission must not be impaired.

### Auto-Transformer

The Type 310D auto-transformer is provided to correct the impedance mismatch occurring between two unlike sections of lines such as open-wire to cable, open-wire copper to open-wire copperweld or iron. It may also be used to match any type of cable or line to other transmission equipment of fixed impedance. Each unit provides for impedance ratios of 1:1, 1:1.5, 1:2, 1:3, and 1:4.

### Balance Coil

The Type D-204 balance coil has been designed to maintain the balance of the phantom circuit when a carrier channel is installed on one side-circuit of a phantom group. Application of carrier equipment results in an increase of the associated side-circuit impedance due to the insertion of the 3 KC low-pass filter. Insertion of the Type D-204 balance coil on the other side-circuit functions to rebalance the two side-circuit impedances.

### Blocking Coil

The Type 115-G blocking coil is available for use in preventing carrier energy from being absorbed by any existing bridged telephone sets. These units are connected in series with one lead of the set and present a high impedance to carrier energy. Standard telephone test sets should be equipped with blocking coils if they are to be used to check operation on a voice-frequency circuit over which carrier equipment is operating.

### Insulating Transformer

The Type D-123 insulating transformers are available for use where there is the possibility of power lines coming in contact with the telephone circuit. The transformers are mounted in an oil-filled tank, (shipped dry) designed for pole-mounting. Windings are tested to withstand a potential of 25000 volts between windings and from windings to case. The insertion loss of these units is from 0.3 db at 20 cycles to 2.5 db at 28.5 kilocycles. If a carrier circuit is installed, existing insulating transformers not designed to pass carrier frequencies must be replaced by units capable of operating at the higher frequencies as well as in the voice-frequency range.

The Type 1B side-line filter is provided for connection between the main carrier line and existing side-lines or branch circuits. If a branch circuit is connected to the main line over which carrier energy is transmitted, serious system disturbances will occur due to the resulting impedance mismatch at carrier frequencies. The installation of the Type 1B filter will materially reduce the reflection losses due to the branch circuit. In the case of longer branches or local conditions that are largely unpredictable, it may be necessary to install complete transfer filter sets. The Type 1B side-line filter is also available mounted in a weather-proof metal pole-box, complete with protectors and by-pass switches.

### Transfer Filter

The Type 2A transfer filter sets are available for use when it is necessary to have access to the voice-frequency conversation without interfering with the carrier energy. An example of this would be a station where the physical is terminated but it is desired to by-pass the carrier circuit around the station and beyond over another physical pair. The Type 2A transfer filter sets are also available mounted in a weatherproof metal pole-box complete with protectors and by-pass switches.

### Repeating Coil

The Type 200 AF repeating coils are designed to pass all frequencies from 20 cycles to 28.4 kilocycles. Their application is required when it is desirable to couple the carrier energy on the station side of the repeating coils. Most standard repeating coils will not necessarily pass the carrier frequencies. In many instances, the carrier energy may be coupled to the line on the line-side of the existing repeating coils and the special units will not be necessary. The Type 200 AF repeating coil is a multi-purpose simplex and phantom coil have 1:1 or 1:2 ratio connections. Both line and drop sides are balanced for simplex operation.

**STROMBERG-CARLSON**

# Miscellaneous



**Signals, fire extinguishers, Calculagraphs, lamps, connectors, soldering irons, tape, tacks, toggle bolts and screws—these and other necessities are grouped in this section.**

CONTENTS  
SECTION W

**MISCELLANEOUS**

---

	Page
Motor Driven Signals .....	3w
Telecode Relays .....	4w
Vacuum Cleaner .....	5w
Telephone Counters .....	5w
Bells and Buzzers .....	6w
Fire Extinguishers .....	6w
Staple Drivers .....	6w
Calculagraphs .....	7w
Portable Lamps .....	8w
Toll and other Printed Forms.....	8w
Rare Gas Relay .....	9w
Soldering Irons .....	9w
Retractile Telephone Cords .....	11w
Rubber Clothing .....	11w
Clips and Connectors .....	12w
Staples and Nails .....	15w
Insulating Tape .....	16w
Nail and Screw Anchors .....	17w
Toggle Bolts .....	18w
Nails .....	19w
Wood Screws .....	20w
Rectifiers (Battery Eliminators) .....	21w

---

**BENJAMIN MOTOR DRIVEN SIGNALS**

Listed by Underwriters' Laboratories

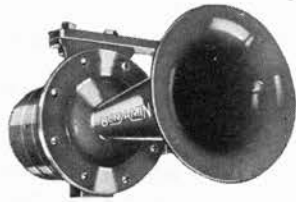

Recommended for machine shops, woodworking departments, steel fabricating shops, stamping and drawing departments and wherever excessive noise is present or the signal must be heard over large areas.

Weatherproof; and assembled throughout with rubber gaskets to exclude moisture.

Supplied with single or double bell type seamless metal projector; single projector is 8½ inches in length, double is 19½ inches overall.

Operates on high torque motor, series wound; on 110 and 220 volts, 60 cycles, a.c. Can also be operated on 50, 40 or 30 cycles.

Baked light gray enamel finish; red enamel finish at a slight additional charge.

Volts	With 8½-inch Bell Type Projector		With Double Bell Type Projector	
	Cat No.	Stock No.	Cat. No.	Stock No.
110	8175—110V A.C.	(892107)	8180—110V A.C.	(892109)
220	8175—220V A.C.	(892108)	8180—220V A.C.	(892110)

**BENJAMIN FACTORY NON-WEATHERPROOF HOWLERS**

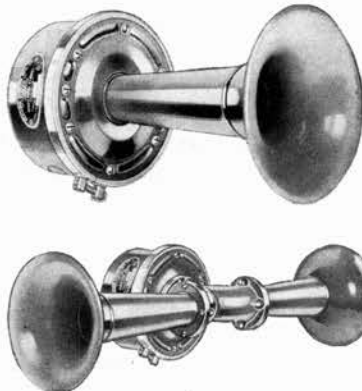

Suitable for use in all locations where signals of weatherproof construction are not required.

The signal housing is of heavy gauge pressed steel, while projectors and grilles are durably constructed. Clamping band is of electroplated copper; rubber gasket seals the joint between the housing and horn assembly.

Operates on either series or multiple circuits. A.C. howler has no contacts; vibrations follow cycles of a.c. Pitch is double frequency of current used.

Housing has one ½-inch size conduit knockout at the back and one at the side and two sets of mounting holes, spaced on 2¾ and 3½-inch centers. Double projector type is used with No. 8731 adapter plate.

Baked light gray enamel finish; red enamel finish, when specified.

Volts	With 7½-inch Bell Type Projector		With Double Bell Type Projector	
	Cat No.	Stock No.	Cat. No.	Stock No.
†12	8755—12V A.C.	(892123)	8795—12V A.C.	(892131)
†24	8755—24V A.C.	(892124)	8795—24V A.C.	(892132)
110	8755—110V A.C.	(892125)	8795—110V A.C.	(892133)
220	8755—220V A.C.	(892126)	8795—220V A.C.	(892134)

Projector-Less Type Grille Front			
†12	8741—12V A.C.	(892135)	
†24	8741—24V A.C.	(892136)	
110	8741—110V A.C.	(892137)	
220	8741—220V A.C.	(892138)	

† Unsuitable for use with low voltage signals. Signaling transformers are required.

25-cycle, in all voltages, supplied when specified at 60-cycle prices.

**BENJAMIN HEAVY-DUTY WEATHERPROOF HOWLERS**

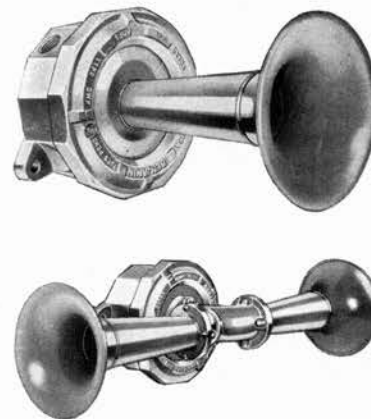

Ideal for effective calling or warning in industrial and commercial locations. Can be used on circuits containing practically any type of signals without affecting operation.

The threaded ring separable construction and plug-in type of wiring connection, assures quick, simple installation. Operates on either series or multiple circuits.

Supplied with a 7½-inch seamless bell type projector, a 14-inch seamed conical projector, or a double bell type projector, 19½ inches overall. Identical outlet box housings and union attaching rings are supplied on all signals, assuring complete interchangeability of projectors.

The outlet box housing is a heavy metal casting to which the projector assembly is attached by the cast aluminum threaded union ring. The joint between these two assemblies is sealed by a rubber gasket.

A.C. howler has no contact; vibrations follow cycles of a.c.; pitch is double frequency of current used. Operates on 60 cycles, 12, 24, 110 or 220 volts; 25 cycles can be furnished when specified.

Baked light gray enamel finish; red enamel finish when specified.

When ordering, specify voltage and frequency.

Volts	With 7½-inch Bell Type Projector		With Double Bell Type Projector	
	Cat No.	Stock No.	Cat. No.	Stock No.
*12	8546—12V	(892111)	8590—12V	(892119)
*24	8546—24V	(892112)	8590—24V	(892120)
110	8546—110V	(892113)	8590—110V	(892121)
220	8546—220V	(892114)	8590—220V	(892122)

\* The low capacity of bell ringing transformers makes howler unsuitable for use with low voltage signals. Signaling transformers are required.

25-cycle, in all voltages, supplied when specified at 60-cycle prices.

## BENJAMIN WEATHERPROOF FIRE ALARM HOWLERS

Listed by Underwriters' Laboratories

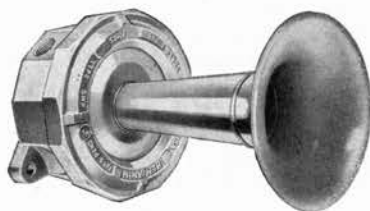

For use on fire alarm systems operating under stringent regulations.

The threaded ring separable construction, and plug-in type of wiring connection, assures quick, simple

installation. A.C. howler has no contact; vibrations follow cycles of a.c. Pitch is double frequency of current used. The diaphragm is sealed by a gasket; diameter, 4 3/8 inches.

Operates on 60 cycles, 110 or 220 volts; 25 cycles can be furnished, when specified.

The horn assembly consists of a 7 1/2-inch seamless bell type steel projector permanently attached to a pressed steel cover on which is mounted the horn mechanism. Baked red enamel finish.

When ordering, specify voltage and frequency.

Volts	Cat. No.	Stock No.	Ship Wt. Lb.
110	8566—110V A.C.	(892143)	6 3/4
220	8566—220V A.C.	(892144)	6 3/4

60-cycle standard. 25-cycle in all voltages, supplied at 60-cycle prices.

## BENJAMIN MINE TYPE HOWLERS Listed by Underwriters' Laboratories



This sturdily constructed howler is effectively sealed against dust and moisture.

Operates on either series or multiple circuits. A.C. howler has no contacts; vibrations follow cycles of a.c. Pitch is double

frequency of current used. Diaphragm is 4 3/8 inches in diameter.

Separable type construction, with the plug-in type of wiring connection. Sealed against moisture with 8-inch insulated wire leads which enter the housing through a water tight bushing.

The detachable horn assembly consists of a 7 1/2-inch, drawn steel bell projector welded to a gasketed steel cover on which is mounted the signal mechanism. This assembly is joined to the housing by a metal clamping band.

Baked battleship gray enamel finish.

When ordering, specify voltage and frequency.

Volts	Cat No.	Stock No.	Ship Wt. Lb.
*12	8652—12V A.C.	(892139)	4
*24	8652—24V A.C.	(892140)	4
110	8652—110V A.C.	(892141)	4
220	8652—220V A.C.	(892142)	4

\*Require signal transformers, as bell ringing type does not have sufficient capacity.

60-cycle standard. 25-cycle in all voltages supplied at 60-cycle prices.

## BENJAMIN TELECODE RELAYS

Listed by Underwriters' Laboratories

For telephone ringing extension and closed circuit alarm systems in factories, mines, quarries, foundries, machine shops and similar places where great volume of noise makes it difficult to hear ordinary telephone bell.

Supplied with contacts arranged for open circuits, contacts open until coil is energized; with contacts arranged for closed circuits, contacts closed until the relay is actuated by current flowing through the coils; and with locking armatures, special winding on coils locks the contacts when the relay is operated, giving continuous operation to signals until signal circuit is broken by a release switch. Contacts are of tungsten steel; coils are form wound with moisture-proof coverings.

Rated .8 ampere at 110 volts, sufficient to operate 5 vibrating type howlers. Standard coil windings are 1000 ohms for operation on 110 volt, 60 cycle, a.c. circuits.

Light gray enamel finish.

When ordering, specify resistance of telephone bell ringer coils, or voltage and frequency of ringing circuit.

Relays with condensers should be specified for use with common battery telephone lines.

### For Panel Mounting

#### Less Condenser

For direct panel mounting; also used as the basis of all combinations listed below.

Has a bakelite base, 4 1/4 inches in diameter, with 2 mounting screw holes spaced on 3 1/2-inch centers.



Cat. No.	Stock No.	Description	Ship. Wt. Lb.
8313-P	(892145)	Open Circuit	2 1/2
8313-C	(892146)	Closed Circuit	2 1/2
8313-L	(892147)	Locking Armature	2 1/2

For special resistance windings add \$.65.

### With Explosion Proof Box

The box has a cast iron base, threaded to take a cast red brass cover. The joint between the cover and base of the box is close fitting deep flanged and of sufficient depth to prevent the escape of flames to the surrounding atmosphere in the event of internal explosion.

Base has 2 mounting lugs and 2 hubs equipped with conduit stops.

The main section is 5 1/2 inches in diameter and tapped 1/2-inch straight through standard; tapped 3/4-inch, when specified.



#### Less Condenser

Cat. No.	Stock No.	Description	Ship. Wt. Lb.
8319-P	(892153)	Open Circuit	10 1/2
8319-C	(892154)	Closed Circuit	10 1/2
8319-L	(892155)	Locking Armature	10 1/2

#### \*With Condenser

8320-P	(892156)	Open Circuit	11 1/4
8320-L	(892157)	Locking Armature	11 1/4

For special resistance windings add \$.65 per Relay.

\*Condenser rated 2 mf.

STROMBERG-CARLSON

**BENJAMIN TELECODE RELAYS (Cont.)**

**With Water Tight Box**

Same type as the explosion proof box, but has cast aluminum cover with a rubber gasket sealing the deep threaded joint between the base and cover.

**Less Condenser**

Cat. No.	Stock No.	Description	Ship. Wt. Lb.
8322-P	(892158)	Open Circuit	7½
8322-C	(892159)	Closed Circuit	7½
8322-L	(892160)	Locking Armature	7½

**\*With Condenser**

8323-P	(892161)	Open Circuit	8¼
8323-L	(892162)	Locking Armature	8¼

Special resistance windings on special order.

\*Condenser rated 1 mf.

**With Pressed Steel Box**

For general use indoors.

The box is approved steel construction with a hinged cover, 6 x 6 x 4 inches in size. With ½-inch knockouts on all 4 sides.

**Less Condenser**

Cat. No.	Stock No.	Description	Ship. Wt. Lb.
8315-P	(892148)	Open Circuit	5¼
8315-C	(892149)	Closed Circuit	5¼
8315-L	(892150)	Locking Armature	5¼

**\*With Condenser**

8316-P	(892151)	Open Circuit	6
8316-L	(892152)	Locking Armature	6

Special resistance windings on special order.

\*Condenser rated 1 mf.

**G-E HANDY ELECTRIC CLEANER AND TOOLS**



G-E Telephone Switchboard Cleaners are specially designed "nonconductors," and are used and recommended by telephone engineers and radio station engineers for cleaning switchboards and other difficult-to-clean electric equipment. This equipment includes, in addition to the bag, an extension hose, shoulder strap, fiber shield, and various brushes required for intricate, inaccessible cleaning tasks.

**MODEL NO. 66—¼ HP**

Heavy-duty ¼-hp blower. Universal-type, ball-bearing motor, a-c/d-c. Maximum vacuum 19 in. (water gage). Volume, 90 cu. ft. of air a minute. Weight, 7 lb. Stock No. (893508)

**NO. 8 VEEDER-ROOT TELEPHONE COUNTERS**



Designed to record incoming or outgoing telephone calls, but can be used for many purposes in the office.

A socket plate furnished with the counter is designed to go flush into the desk or table. Into this socket plate the counter can be inserted or removed at will. Each depression of the lever registers one on the counter.

Catalog No. 8 Stock No. (893417)

**NO. AB2 VEEDER-ROOT HAND TALLY COUNTERS**



For use in the office, factory, at home, out of doors, or anywhere. It counts anything. Fits easily and comfortably in the hand of the user. It is so designed that it can be operated with either hand. Each depression of the easy action thumb lever registers one on the counter. It will count up to 10,000. One complete turn of the reset

knob on the right of the counter instantly resets the figures to all zeros.

The small case is designed with rounded edges so as not to irritate the hand of the user nor wear the pocket when carried.

Catalog No. AB2 Stock No. (893418)

**AIR-DRYING DULL BLACK ENAMEL**

Air-drying dull black enamel for retouching desk stands, hand sets, metal wall telephones, metal bell boxes and other dull black finished apparatus.

Size Can	..... ½-Pt.	1-Pt.	1-Qt.
Stock No.	..... (893519)	(894122)	(894123)

STROMBERG-CARLSON

## FARADAY MARLO BELLS AND BUZZERS DOUBLE MAGNET, ADJUSTABLE

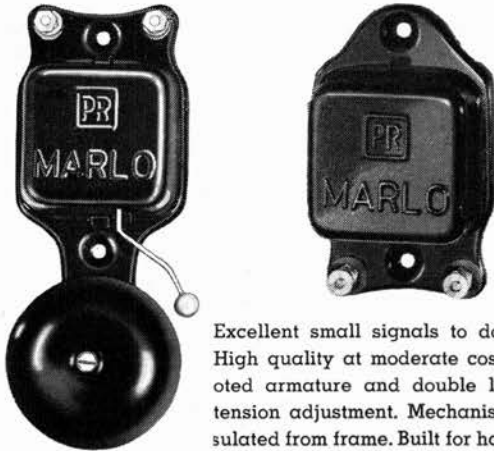

Excellent small signals to do big jobs. High quality at moderate cost. Has pivoted armature and double lock spring tension adjustment. Mechanism fully insulated from frame. Built for hard service. Black case and gong. Operate on 6-8 volt

A.C. 60 cycle or 3-6 volt D.C.

Special coil voltages and resistances can be furnished.

Catalog No.	Stock No.	Type	Standard Number	Package	Shipment. Wt.
571	(894806)	2½" Bell	10	6¾ lbs.	
572	(894807)	3" Bell	10	7¾ lbs.	
573	(894808)	4" Bell	10	9¾ lbs.	
570	(894809)	Buzzer	10	5 lbs.	

## LOUD RINGING BELLS



A rigidly made bell, designed for outdoor and indoor service. Stamped steel case, heavily enameled; and 6-inch gongs are pressed steel, heavily galvanized.

Ringer coils are treated with weatherproof insulating varnish.

In ordering specify resistance required. Standard

is less condenser. For use on common battery lines condenser should be specified.

Gongs of 6" pressed steel.

Illustrated with cover removed.

Cat. No.	Stock No.	Description
53-A	(801865)	1000 ohms less condenser
53-C	(801866)	1600 ohms less condenser
53-F	(801867)	2500 ohms less condenser
53-A	(49049)	1000 ohms with condenser
53-C	(49050)	1600 ohms with condenser
53-F	(49051)	2500 ohms with condenser

## PYRENE FIRE EXTINGUISHER LIQUID



Anti-freezing, non-corroding, and non-conducting.

Cat. No.	Stock No.	Size Can	No. in Carton	Ship. Wt. Lb.
CR2	(893512)	1-Qt.	20	77½

## PYRENE FIRE EXTINGUISHERS

Safe for use on electrical fires of all kinds as the liquid is non-conductive and will not injure electrical equipment.

The contents will not freeze at 50° below zero. Needs no recharging until used.

The 1 and 1½-quart sizes are labeled by the Underwriters' Laboratories.

Made of brass and equipped with bracket.

### NO. C-21

Capacity, 1 quart.

Packed 6 in a carton.

Shipping weight per carton, 45 pounds.

Catalog No. C-21 Stock No. (893509)

### NO. C-31

Capacity, 1½ quarts.

Packed 12 in a carton.

Shipping weight per carton, 140 pounds.

Catalog No. C-31

Stock No. (893510)

## NO. C-43 1-GALLON PRESSURE TYPE

Especially adapted for large industrial use and all electrical equipment needing greater capacity.

Successful extinguishment often requires rapid application of a large volume of fire extinguishing agent delivered on the fire at high pressure. This extinguisher discharges completely from 30-33 seconds.

Inspected and labeled by the Underwriters' Laboratories and approved by the Associated Factory Mutual Laboratories.

Of polished copper with wall bracket.

Height over all, 24 inches.

Diameter of tank, 6 inches.

Weight of extinguisher filled, ready for use, 32 pounds.



Carrying strap or vehicle bracket are available.

Catalog No. C-43

Stock No. (893511)

## NO. 500 WALSCO STAPLE DRIVERS

Designed for the installation of telephone and inter-communicating equipment. Automatically sets the staple in place with a minimum of effort.

Feeding mechanism operated by small trigger, controls the staples leaving the magazine. Magazine holds 23 staples for wire up to ¼-inch diameter. Staples come in strips and can be loaded in a few seconds.

Adjustable fitting regulates the depth to which staple is to be driven into surface, thus avoiding damage to insulation or wire.

Staples are high quality carbon steel, rust-proof and lacquer coated. Available in brown and ivory.

Complete directions with every staple driver. Initial order includes one box of 250 staples.

Catalog No. 500 Stock No. (893074)

### Staples Only

Catalog No. 552 Stock No. (893075)





Model 6



Model 33



Model 30

Calculagraph is the simple, time-saving instrument that records starting and elapsed time on telephone toll tickets. Any number

of calls can be computed without confusion and the printed record remains legible for years.

**MODEL 6: SPRING DRIVE**

Eight day, jewelled, heavy duty marine movement. Records the time of day in hours and minutes. Records elapsed time figured in minutes and quarter-minutes with a five second indicator after each minute. Records elapsed time for 60 minute periods. Model 6 interchangeable with Model 30 as each has the same outside dimensions, 8 3/4" diameter. Model 6 is available with three different printed record styles.

1. Model 6: Standard Model: (12 T.O.D.) Prints a 12 hour time of day record with either the A.M. or P.M. stamped as needed.
2. Model 6: (24 T.O.D.) Prints a 24 hour time of day record.
3. Model 6: (Dating Stamp Model) Either Model 6 Calculagraph listed above (12 T.O.D. or 24 T.O.D.) can be supplied with a special date printing device when demanded.

Stock No. (893434)

**MODEL 30: ELECTRIC DRIVE**

Equipped with self-starting, jewelled bearing, synchronous motor for 20 volts, 50 or 60 cycles; or 115 volts, 50 or 60 cycles. Current consumption 2 watts. Records time of day in hours and minutes. Records elapsed time figured in minutes and seconds for thirty minute periods. Model 30 interchangeable with Model 6 as each has the same outside dimensions, 8 3/4" diameter. Model 30 available with three different printed record styles.

1. Model 30: Standard Model (12 T.O.D.) Prints a 12 hour time of day record with either the A.M. or P.M. Stamped as needed.
2. Model 30: (24 T.O.D.) Prints a 24 hour time of day record.
3. Model 30: (Dating Stamp Model.) Either Model 30 Calculagraph listed above (12 T.O.D. or 24 T.O.D.) can be supplied with a special date printing device when demanded.

Stock No. (893438)

**MODEL 33: ELECTRIC DRIVE**

Equipped with self starting, jewelled bearing, synchronous motor for 20 volts, 50 or 60 cycle; or 115 volts, 50 or 60 cycles. Current consumption 2 watts. Records time of day with a 24-hour printed dial. Records elapsed time figured in minutes and seconds for thirty minute periods. Has hour, minute and sweep second hand on visible dial. Case 6 1/2" long, 3 3/8" wide, 3 3/4" deep.

Stock No. (893440)

**TRANSFORMERS**

Where it is desirable to keep 110-115 volt current away from talking circuits and outside the switchboard, step down transformers are available in these stock sizes.

1. Single Unit Transformer (To operate one Calculagraph)  
Stock No. (893443)
2. 7 Unit Transformer (To Operate 1 to 7 Calculagraphs inclusive.)  
Stock No. (893442)

Both transformers operate from a line or primary voltage of 110-115 volts, 50-60 cycles A.C. Secondary voltage is 20 volts, 50-60 Cycles A.C.

**PORTABLE PEDESTAL MOUNTING**



Where space is not available for regular switchboard mounting, CALCULAGRAPH Pedestals provide a simple solution. Pedestal mounted instruments may be moved as needed to speed service as busy spots develop at various locations in the exchange. Height of the pedestal is adjustable from 26 to 40 inches from floor to ticket plate. All model CALCULAGRAPHS may be pedestal mounted. Model 6 and Model 30 CALCULAGRAPHS are mounted using only a type "A" case. Model 33 CALCULAGRAPHS are pedestal mounted using a special pedestal case. Specify these cases if the units are to be pedestal mounted. Weight of pedestal 40 lbs.

Stock No. (893444)

**SNAP-ON INK RIBBONS**

SNAP-ON Ink Ribbons are specially made for CALCULAGRAPHS. They produce a readable and durable print that remains legible permanently. Blue record color is standard and recommended, other colors can be furnished if required.

Stock No. (893441)

## U-C-LITE BIG BEAM NO.700-A



Projects a ray over 2000 feet. Scientifically constructed with 6-inch true parabolic silvered reflector, long life prefocused bulb and simple head adjustment through a vertical arc. It sets a new high standard in dependable portable illumination of unusual power, convenience and economy.

The No. 700-A has chrome plated head; handle and rim. It is equipped with two bulbs: a main bulb, and an auxiliary which draws little current and will, therefore, last for many more hours. Operates at maximum efficiency for any all night service job on 4 No. 6 dry cells.

Interchangeable flood-light lens if desired (optional). Snap-on floodlight lens can be furnished at additional charge.

Stock No. (893408)

## BIG BEAM MODEL NO. 211 PORTABLE ELECTRIC HAND LAMP



Throws a powerful 1,500-foot light beam for hundreds of utility and emergency uses. An emergency light for all purposes: electrical failure in storms, repair at night.

The most unusual feature of this lamp is its light weight—only 3¼ lbs. without batteries or 5½ lbs. with batteries.

Main and auxiliary bulbs.

Double-throw switch with finger-tip control. Simple focus adjustment for spot and spread light. Powered by standard dry cell lantern batteries. Pressure contacts. No wires to connect. Perfectly balanced for carrying. Compact. Weatherproof, rustproof. Stock No. (894800)

## BIG BEAM MODEL NO. 400-F ELECTRIC FLARE



This flashing flare was designed to give maximum visibility with endurance and dependability. Can also be used as a regular lantern. The steel container, similar to the No. 211, is 5½" x 3" x 5½". Operates on standard 6-volt batteries; burning life 28 hours continuous flashing, 20 hours steady flare. A flip of the switch sets lantern for flashing (approx. 120 per minute) or steady flare (visible in all directions over 600 feet). Colored lens easily replaced with clear lens.

Weight of the complete unit, 4¾ lb. Stock No. (894860)

## STOCK FORM TROUBLE TICKET Form T-71 For Class C and Class D Companies

TROUBLE TICKET						No. _____
Sub No.	Time		A. M.	Date	194	
Trouble reported by Subscriber—Operator—Manager			CAN'T GET CENTRAL		SUBSCRIBER DON'T ANSWER	
Bell Rings when Other Party is Called	Open	Cuts Off	Can't Hear	Bell Don't Ring	Reversed	
	Noisy	M. P. Broken	Can't be Heard	Burning	Crossed Line	
Receiver Broken	Receiver off Hook	Wire Broken	Hook Trouble	Tip Out. Rec.		
Sub. Name _____						
Sub. Address _____						
Pin No. _____						
Pin No. _____						
Cable Pole _____						
Tests _____						
Trouble Found _____						
Caused by _____						
Trouble Cleared by _____				Date _____		

Size 3½ x 5½ inches. This ticket lists in detail the trouble as reported by the subscriber or the trouble clerk, making it very easy for the trouble shooter to clear up the trouble in quick time. This saves labor cost as well as wear and tear on your rolling stock. Printed on white bond paper, black ink.

Put up in pads of 100, bundles of 1000.

Minimum Quantity Order ..... 2000  
Stock No. .... (893640)

## STOCK FORM TOLL TICKETS

Forms T-40, T-62, T-82 "Out" Tickets on white paper. Size 2½ x 5 inches. Banded 500 to bundle.

Minimum Quantity Order, 5000	Catalog No.	Stock No.
Forms, T-41, T-63, T-83 "In"	T-41	(893630)
Tickets on yellow paper.	T-63	(893631)
T-64, T-66, T-70 "Sent" Tickets on white paper.	T-83	(893632)
T-64	T-64	(893633)
T-65, T-60, T-69 "In" Tickets on pink paper.	T-66	(893634)
T-70	T-70	(893635)
T-67, "Through" Tickets on yellow paper.	T-65	(893636)
Size 3½ x 4 inches — Furnished padded only.	T-60	(893637)
T-69	T-69	(893638)
Minimum Quantity Order, 1000	T-67	(893639)
Colored tickets available at slightly higher cost.	T-40	(894030)
	T-62	(894031)
	T-82	(894032)

In addition to the above tickets there are many forms which can be supplied upon request if sufficient quantities are ordered. Among these are:

Subscribers Bills, Toll Bills, Rental Receipts, Daily Work Report Blanks, Stock Record Blanks, Voucher Blanks, Pay Roll Blanks, Voucher Checks, Orders on Treasurer, Letterheads and Envelopes, Monthly Check Report Blanks, Bank Checks, Subscribers' Ledgers, General Ledgers, Cash Journals, Voucher Records, Lease and Rental Records, Cash Books, Toll Journals.

**TYPE RTC-2 VINCENT RARE GAS RELAYS**

An electronic device for use on telephone lines instead of mechanical ringing relays. It has no moving parts, may be placed in any position and is unaffected by atmospheric or temperature changes.

Used on magneto or common battery lines, leaving the condensers in where they are used in the bell circuit. Either harmonic or coded ringing bells may be used.

Lines equipped with the relay are free from grounds in normal operation and therefore free from noises which would ordinarily be picked up through grounds.

Prevents premature tripping in machine ringing from manual or dial offices.

Also acts as a protector against lightning discharges and drains off excessive current induction from high tension sources.



Consists of a small glass tube containing a special combination of rare inert gases acting in contact with special metal electrodes, which allow current to pass above a closely pre-determined voltage. The glass envelope is mounted in a heavy bakelite shell for protection. Whole unit is mounted in a special holding clamp with the terminals of the relay presented at convenient points for connections.

Length 2½ inches and height, 1½ inches, when mounted. Furnished complete with mounting.

Stock No. (892163)

**VULCAN SOLDERING IRON TIPS**



No. 35-T



No. 50-T

Each tip accurately machined with a bevel which exactly fits corresponding bevel in end of heater, providing a valve seat joint of exceptional efficiency in the conduction of heat and also, by sealing chamber into which tip screws, protecting surfaces enclosed from corrosion.

Cat. No.	Stock No.	Description
30T	(890832)	Tip Only for No. 30 Soldering Iron
35T	(890833)	Tip Only for No. 35 Soldering Iron
40T	(890834)	Tip Only for No. 40 Soldering Iron
50T	(890835)	Tip Only for No. 50 Soldering Iron

**VULCAN SOLDERING IRONS**

All Vulcan irons equipped with 6-foot approved heater cord and attachment plug cap. Will operate from any light socket on either A.C. or D.C. Standard voltages are 110, 120, 125, 220, 230, and 240 volts.

Vulcan construction is very simple, consisting of but 5 complete parts, all easily replaceable; a tip, a sealed heating head, a handle, a cord and a plug.

All Vulcan irons have cool comfortable handles. Terminals accessible by moving handle from stem onto cord.

Specify voltage when ordering.

**No. 22 Long Shank Iron**



This soldering iron is made extra long—24 inches overall—for convenience in reaching the full depth of the wiring in large multiple switchboards. The tool is rated at 50 watts and has a 6' cord. Tip is 7/16" in diameter, shank is 9/16" diameter.

Stock No. (894887)

**No. 30-Screw Tip Type**



For radio and home use, fuses, instruments, inspectors' or linemen's tool kits, etc.

Equal to 1½ pounds per pair coppers. Net weight, 12 ounces; 60 watts. Stock No. (890828)

**No. 35-Plug Tip Type**



Recommended for telephone inspectors and linemen. Equal to 1½ pounds per pair coppers.

Net weight, 1⅛ pounds; 100 watts. Stock No. (890831)

**No. 40-Screw Tip Type**



For telephone switchboards, electrical instruments, light manufacturing, fuses and radio apparatus.

Equal to 2½ pounds per pair coppers. Net weight, 13½ ounces; 90 watts. Stock No. (890829)

**No. 50-Screw Tip Type**



For fast telephone work, art glass, light automobile repairs, light tinware and general home use.

Equals to 3½ pounds per pair coppers. Net weight, 18 ounces; 130 watts. Stock No. (890830)

**NO. 2100 VULCAN SOLDERING IRON HOLDERS**



Holds and guards soldering tool when not in use. Rubber feet provided so it will not mar or

scratch a highly polished surface.

Without Thermostatic Control. Stock No. (890836)

## ELECTRIC SOLDERING IRONS

The core of the heating unit is made of solid steel rod. Around this steel core is wound chrome-nickel ribbon resistance wire, the various layers of which are insulated with mica of the best grade obtainable for the purpose.

Each of the above irons is equipped with a baffle plate, at the shank, to prevent free conduction of heat to the handle.



No. 3138

**NO. 3138** Designed primarily for production and maintenance in radio, telephone, telegraph, ignition switchboard and telephone installation work and similar industrial applications.



No. 3158

**NO. 3158** For the same purposes as the No. 3138 but for work requiring an iron of greater capacity.

**NO. 3178** For use on still heavier work; for light commutators and service and production work. A very useful iron for general purposes.

**NO. 3198** For heavy work of all kinds. Supplies a large volume of heat at high temperature. Used by manufacturers in many different lines; for shop, service, production work, etc.

### Specifications

Made in standard voltages and for 32 volts.

No. 3138 also made for 6, 12, 24 and 55 volts.

Nos. 3138, 3158, 3178, 3198 can be equipped with three-conductor cord, one wire grounded, at slight additional charge.

Separate heat-insulating stand supplied with each iron.

Cat. No.	Stock No.	Diameter of Tip	Watts	Net Weight	Length Over All	Casing Diameter
3138	(890818)	3/8"	100	16 oz.	12 7/8"	7/8"
3158	(890819)	5/8"	200	28 oz.	13 3/8"	1 1/4"
3178	(890820)	7/8"	300	42 oz.	14 3/8"	1 9/16"
3198	(890821)	1 1/8"	550	60 oz.	15"	1 3/4"

## COPPER SOLDERING TIPS



3738	3758	3778	3798
for	for	for	for
3138	3158	3178	3198
Iron	Iron	Iron	Iron

These copper tips are made from commercially pure, drawn bar, copper rod. Each tip is designed to fit into, and to the full length of, core of heating unit of the particular iron for which it is intended. Maximum area of contact between the tip and heating unit is thus assured. Tips are of uniform diameter throughout their entire length. Each tip is held in place in core of heating unit by a recessed set-screw. Standard shaped tips with which the various models are equipped are shown in the illustration; but pyramidal, instead of chisel type, and vice versa, can be supplied when so specified without additional charge.

Cat. No.	3738	3758	3778	3798
Stock No.	(890822)	(890823)	(890824)	(890825)

## TEMPERATURE REGULATING STANDS



This is a thermostatically controlled device for the regulation of the temperature of an electric soldering iron while at rest. When placed on this stand, soldering iron is maintained at working temperature, ready for instant use or, if desired, at a lower temperature. Through an adjustment on bottom of the stand, thermostat may be set for the maintenance of any desired temperature—from very low, or warm, to full working temperature. Body of stand is of molded plastic. Soldering iron cradle proper is of metal. Stand is equipped with cord and attachment plug-cap for connection to current and with a receptacle for connection of the electric soldering iron. It is designed for use with electric soldering irons up to 660 watts capacity and on circuits up to 240 volts.

Cat. No.	Stock No.	Net Weight
475	(894673)	27 oz.

## WELLER SOLDER GUNS



The Weller Solder Gun heats in 5 seconds, thus saving time and power. The pre-focused spotlight throws light where you need it as you work; like having an extra hand. The inexpensive, readily replaceable loop tip gets in between wiring easily. This tip can be bent to meet the requirements of any particular job. Greater terminal length gets down farther into the switchboard or chassis. Comfortable pistol grip.

Model D-207 has dual heat—100 watts normal heat on first switch position, 135 watts instantaneous on second.

Cat. No.	Stock No.	Watts	Cycles	Volts
S-107	(894666)	Single, 100	60	115
D-207	(894667)	Dual, 100/135	60	115

**RETRACTILE TELEPHONE CORDS**

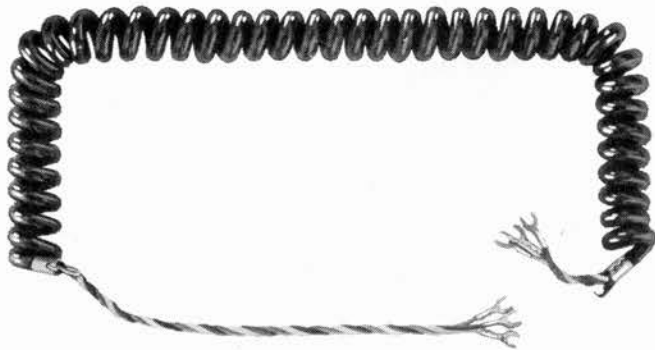

Koiled Kords extend effortlessly to the standard length of straight cord, and retract to a neat one foot of tightly coiled wire, out of the way when not in use.

Koiled Kords are permanently molded into their spring-like shape—no springs or other mechanical means are used. This construction assures longer life because the cord is free of kinks. The conductors are rubber insulated tinsel wire. The outer jacket is neoprene.

Cat. No.	Stock No.	Use
5001-1	(894826)	For use on Kellogg No. 1000 series Desk and No. 1100 series Wall Masterphones.
5001-2	(894827)	For Kellogg No. 900, 925, 9900, 9917 series and other Masterphones using a No. 27-C handset.
5001-3	(894828)	For use on Stromberg-Carlson, Western Electric and North Electric handset type telephones.
5001-4	(894829)	For use on Automatic Electric handset type telephones.
5001-5	(894830)	For use on Leich Electric handset type telephones.



**NEOPRENE LATEX CLOTHING**

Used by public utility and industrial workers for any job requiring protection against water, acid, grease or paint. Unusually light in weight (approximately half the weight of the old-style rubber garments). No seams to open, as all garments are first sewn and then hand brushed inside and out with Neoprene. These garments will not become tacky in warm climates nor extremely stiff in cold temperatures. All patterns are cut extra full to allow complete freedom for the wearer.

Marked Sizes:	00	0	1	2	3
Chest for Jackets:	46"-48"	44"	42"	38"-40"	36"
Waist for Pants:	46"-48"	44"	42"	38"-40"	36"

Cat. No.	Stock No.	Description
534-L	(894865)	Neoprene Linemen's Jacket
530-L	(894866)	Neoprene Linemen's Pants
661	(894867)	Buna Rubber Linemen's Hat

**LINEMEN'S RUBBER GLOVES**

**Rolled Top**



A standard curved fingered linemen's glove built to A.S.T.M. specification in all details. Uniform at all points. Steam cured, lowest leakage, slow aging and great flexibility.

Tensile strength, 2500 pounds.

Length, 14 inches; half sizes from 9 to 12.

Type .....	A	B
Volt Weight .....	15,000	10,000
Stock No. ....	(892651)	(892652)

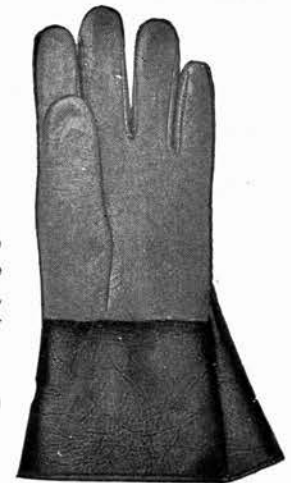

**LEATHER PROTECTORS**

Furnished in two grades for above linemen's gloves—Style 1055, the ordinary protector and Style 1260, the special high grade, soft leather protector.

Style .....	1055	1260
Stock No. ....	(892653)	(892654)



**RUBBER GLOVE CARRIERS**

Made of 4/0 (36 oz.) hard woven duck with heavy webbing gussets. Front, bottom, back and flap made of one-piece, which adds materially to the strength and life of the bag. It is equipped with the BUHRKE two-way snap for convenience in detaching from dee ring. Ventilating eyelets in bottom.

No. 1106—8" wide, 15" long,  
Expansion 5 1/2" at top, 2 3/4" at bottom.  
Stock No. (892656)

**RUBBER COATED COTTON GLOVES**

These are regular 8oz. cotton gloves dipped in a solution of natural rubber all the way up to the wrist. The inside is soft and keeps perspiration down. Natural curve to fit the hand. Knit wrist clings tight. Equally useful for work with hot or cold materials. Offer protection from heat, cold acid, water, steam.



Catalog No. 1036  
Stock No. (894868)

## KEARNEY GUY WIRE CLIPS



Kearney Guy Wire Clips serve up strand ends quickly and securely. They are stamped half formed to fit the guy strand, and are made in six sizes of aluminum, galvanized iron and copper. Two small indentations are punched in the clips to prevent it from twisting or loosening on the strand. While these clips are easily installed with a pair of pliers, a quicker and neater job is obtained with the Guy Wire Clip Tool illustrated.

Cat. No.	Stock No.	Size of Strand Inches	Strand Rating	Weight Lb. Per 100
----------	-----------	-----------------------	---------------	--------------------

### Aluminum

400	(891768)	1/4	4M.	2
36	(891769)	5/16	6M.	2
37	(891770)	3/8	10M.	2 1/2
38	(891771)	7/16	16M.	2 1/2
401	(891772)	1/2	25M.	2 3/4
39	(891773)	9/16	—	2 3/4

### Galvanized Iron

402	(891774)	1/4	4M.	3
336	(891775)	5/16	6M.	3
337	(891776)	3/8	10M.	3 1/2
338	(891777)	7/16	16M.	3 1/2
403	(891778)	1/2	25M.	4
339	(891779)	9/16	—	4

### Copper

404	(891780)	1/4	4M.	3 1/2
436	(891781)	5/16	6M.	3 1/2
437	(891782)	3/8	10M.	4 1/2
438	(891783)	7/16	16M.	4 1/2
405	(891784)	1/2	25M.	5
439	(891785)	9/16	—	5



## NO. 2102 KEARNEY GUY WIRE CLIP TOOLS

This handy tool provides a quick means of installing Kearney Guy Wire Clips neatly and permanently.

Tool is of light weight, durable stamped steel. Provided with a ring to permit hanging on a lineman's belt.

Proper adjustment of the tool for handling various size clips is easily made and determined by gage arrows clearly marked on the side of the tool.

Length, 14 3/8 inches.

Shipping weight, 3 pounds.

Catalog No. 2102 Stock No. (891786)

## KEARNEY DROP WIRE GRIP



An efficient drop wire grip for attaching telephone drop wire to poles and buildings. The "snubbing" action of this grip is greater than the rated strength of the conductors, because strain is distributed throughout the length of the grip. This prolongs the life of drop wire and permits free swinging of the tie. Also, the smooth spiral channel makes it unnecessary to "parallel" twisted pair wire.

Cat. No.	Stock No.	Material	Length	Approx. Ship. Wt. per 100
6715	(893044)	Copper	8 1/2"	12 pounds
6715-1	(893045)	Steel	8 1/2"	12 pounds

## RELIABLE DROP WIRE CLAMP



Parallel Wire

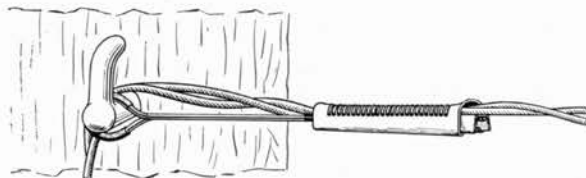

Twisted Pair Wire

An ideal device for attaching twisted pair or parallel drop wire to poles and buildings. It prolongs the life of the installation, permits free swinging at the tie, places all the wear on the hardware and eliminates sharp bends in the insulation.

The Drop Wire Clamp makes a very neat appearing installation. It is easy and quick to install. Two of them can be used to make an angular turn. Slack in drop wires can be taken up very quickly without leaving any weak spots. Clamp is wedge-shaped, with a copper wire loop at one end for hooking over a common drive hook, masonry hook or porcelain knob. When using twisted pair, it is essential to parallel the wires through the clamp.

Clamps will accommodate standard No. 18, No. 17, No. 16, or No. 14 A.W.G. twisted pair or parallel drop wire with neoprene, braid or plastic-covered.

Cable, Twisted Pair or Parallel; Range of Clamp, .160" Max., .140" Min., Width .250"; Bail Length 4"; Standard Package 25; Shipping Weight per 100 14 Lbs. Cat. No. P, Stock No. (893046)

Same Style as above, but for use with No. 14 A.W.G. Cat. No. R, Stock No. (893047)

Steel Drive Hooks Hot Dipped Galvanized 7/16" Diameter; 5 1/4" Long. Stock No. (894239)

**KEARNEY HOUSE AND POLE HOOKS**



The drop wire hook is a popular and inexpensive house hook, especially suited for use on hollow tile wall and similar construction. The drive hook has been designed for a variety of applications. It is made in the large size for pole use, and in a smaller size for house use.

Cat. No.	Stock No.	Description
8031	(893048)	Drop Wire Hook
6766-1	(893049)	Small Drive Hook, 3 1/2" long, 5/16" dia.
6766-3	(893050)	Large Drive Hook, 4 1/2" long, 7/16" dia.

**NO. 6296 PARALLEL DROP WIRE CLIPS**

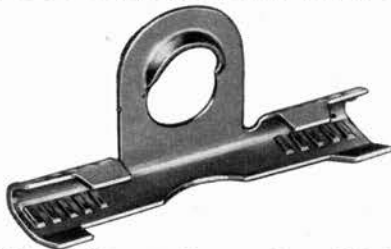

For use at intermediate attachments of parallel drop wire. A small clip with supporting lip and specially formed hole fit drive hooks, masonry hooks and knob adapters.

Wire is placed in supporting groove and the small tongues of the clip are crimped down. The pressure grips the wire firmly but does not injure the insulation.

Catalog No. 6296 Stock No. (893051)

**KEARNEY DROP WIRE CLIPS**

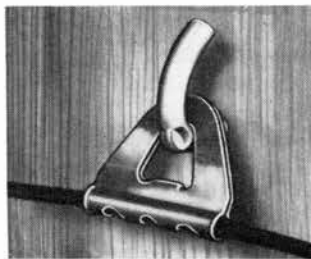

**For Intermediate Drop Wire Attachments**

This reliable clip can be used either with parallel or twisted pair drop wire, where intermediate fastenings are desired on straight line drop extensions. They

are carefully designed to grip drop wire tightly without damaging the wire.

Catalog No. 11452 Stock No. (894836)

**BRIDGING CONNECTOR**  
For Use on Telephones, Telegraph and Signal Lines



A strong connector, for galvanized iron wire, cold forged of 98% copper alloy with a weather-resisting coating which minimizes galvanic corrosion. Washer type is recommended for use with copper tap wire.

Cat. No.	Stock No.	Steel Sol. B.W.G.	Copper Sol. A.W.G.	Slot Size Inches	Standard Package	Ship. Wt. Lb.
109	(893090)	12	9	.109"	100	2
109W	(893091)	12	9	.109"	100	2 1/2

**KEARNEY TELEPHONE CON-NEC-TITES**



An inexpensive and reliable means of making bridge or test connections in telephone work. Small and compact in size.

Galvanic action between iron and copper is eliminated by the use of a plated separating washer which places like metals together—thus assuring maximum pressure distribution.

**Copper to Copper Connection**

Cat. No.	Stock No.	Maximum Wire Size	No. of Washers	Wt. Lb. per 100
86-7	(893092)	12 NBS-10 B&S	1	2
986-7	(893093)	12 NBS-10 B&S	2	2
89-2	(893094)	10 NBS-8 B&S	1	3
989-2	(893095)	10 NBS-8 B&S	2	3

**Iron to Iron Connection**

2451-7	(893096)	12 B.W.G.	1	2
2449-7	(893097)	12 B.W.G.	2	2

**Iron to Copper Connection**

5694-7	(893098)	12 B.W.G.-12 NBS	2	2
--------	----------	------------------	---	---

**C-R SERVICE CONNECTORS**



For connecting copper, or bronze or copperweld drop or service wires to galvanized iron or copper line wires, or for multiple service and party-line connections, pole jumper wires, ground-wire connections, etc.

The C-R Tinned Service Connector has the head, slot and one washer heavily coated with tin which prevents electrolytic and corrosive action between the zinc coating of the iron wire and the copper wire and should always be used on galvanized iron wire.

Made in two types, tinned for galvanized iron to copper wire connections and plain brass for copper to copper wire connections. When ordering state whether tinned or plain brass connectors are wanted.

Furnished in four sizes:

No. 1. Made in nickel finish brass only. Used for splicing drop wire, multiple taps on drop wire, connecting house wire to drop wire, etc. 1/4-inch brass bolt with 3/8-inch hexagon head and nut, slotted to receive No. 14 B&S gage, No. 17 B&S gage and smaller wires.

No. 2. 5/16-inch brass bolt with 7/16-inch hexagon head and nut slotted to receive No. 12 B&S gage, No. 14 N.B.S. gage and No. 14 B.W. gage wires.

No. 3. 7/16-inch brass bolt with 5/8-inch hexagon head and nut, slotted to receive No. 10 B&S gage, No. 12 N.B.S. gage and No. 12 B.W. gage wires.

No. 3A. 3/8-inch brass bolt with 1/2-inch hexagon head and nut, same capacity as No. 3 but lighter construction.

Cat. No.	Stock No.	Type
1	(893081)	Nickel
2	(893082)	Brass
2	(893083)	Tinned
3	(893084)	Brass
3	(893085)	Tinned
3A	(893086)	Brass
3A	(893087)	Tinned

## KEARNEY WEDGE-TITE CLAMPS



Kearney Wedge-Tite dead-end fittings provide full strength and economical open wire dead-ends. The fitting is easily installed with a pair of ordinary pliers; special tools are unnecessary. The Wedge-Tite is re-usable and should line alterations, or repairs, necessitate disturbing a line dead-end, the fitting can

be readily removed and reinstalled. A splicing tail of wire, of any desired length, can be left at the time of installation.

The Wedge-Tite is made of stainless steel, and can be supplied in three sizes, accommodating the most commonly used wires.

Cat. No.	Stock No.	Wire Size	
		Copper	Iron
7408-2	(894818)	No. 10 (.102")	No. 12 (.109")
7409-2	(894819)	No. 8 (.128")	No. 10 (.134")
7410-2	(894820)	No. 12 (.080")	No. 14 (.083")

## KEARNEY DRY SPOT

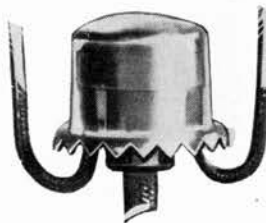

Kearney Dry Spot Insulators are used with parallel type drop wire whenever the outer protective braid is removed in making a weather exposed connection. The Dry Spot is composed of two transparent parts that lock together and provide easy visual inspection of the wire. The Dry Spot is so designed that should

the conductors become completely bare between the line connection and the end of the protective braid, there is no current leakage. This eliminates the service hazards of exposed rubber insulation deterioration.

No special tools are required and changes in present drop insulation practices are unnecessary.

The Kearney Dry Spot also makes parallel type drop wire practical for many additional uses, where, formerly, a more expensive wire was considered necessary.

Catalog No. 12441 Stock No. (894821)

## UNIVERSAL TEST CLIPS

### No. 27



With No. 29 Insulator

For use with test sets, with volt-meters, on shop testing devices, by telephone linemen, by meter departments, by railway signal inspectors, in college and commercial laboratories and in radio work.

Steel clip, cadmium-plated, with screw. Capacity, 20 amperes; length, 2<sup>5</sup>/<sub>16</sub> inches; jaw spread, 9/<sub>16</sub> inch; 12-pound spring; teeth on all three sides of both jaws.

No. 29 Insulator, Stock No. (892183) may be ordered separately if desired.

Shipping weight per 100 clips, 3<sup>1</sup>/<sub>4</sub> pounds.

Insulators packed half red and half black, 10 to a box, 10 boxes to a standard carton. Shipping weight per 100, 5<sup>1</sup>/<sub>4</sub> pounds.

Catalog No.	Stock No.
27	(892181)
*27	(892182)

\*With No. 29 insulator.

### No. 82



A needle clip for telephone and signal work. To make quick, temporary electrical connections by piercing insulated wires.

Steel, cadmium-plated, with screw. Capacity, 10 amperes; length, 2 inches; jaw spread, 1/2-inch; 10-pound spring.

Needle set to one side so it is easy to locate on a wire and so jaws will grasp a terminal if needle is not used.

Shipping weight per 100, 2 pounds. Stock No. (892179)

### No. 60 Series Alligator Clips



No. 60-S



No. 60-HS

Accurately made, slim jaws, fine meshing teeth for test work in close quarters. Convenient round thumb grip, barrel connection for banana plug. Has small soldering lip, or wire may be staked in barrel by use of staking tool or in small bench press die in production assembly. Strong hinge to prevent jaw offset, spring gives hard bite. Bright, attractive finish. Packed 100 per box. Shipping weight 1 lb. per 100.

No. 60-S. Screw Connection Alligator Clip has screw connection that eliminates necessity for soldering. Packed 100 per box. Shipping weight 1 lb. per 100. Stock No. (894108)

No. 60-HS. Steel Alligator Clip with Insulated Handle is equipped with red and black insulating sleeves on end. Very convenient for distinguishing leads. Packed 100 per box—50 red, 50 black. Shipping weight 2 lbs. per 100. Stock No. (894109)

### No. 85 Crocodile



With No. 87 Insulator

Steel, cadmium-plated, with screw and barrel. Capacity, 5 amperes; length, 2<sup>3</sup>/<sub>8</sub> inches; jaw spread, 1/2 inch.

No. 87 Insulator, Stock No. (892187) may be ordered separately if desired.

Shipping weight per 100, 1<sup>1</sup>/<sub>2</sub> pounds.

Shipping weight per 100 insulators, 1 pound.

Catalog No.	Stock No.
85	(892185)
*85	(892186)

\*With No. 87 Insulator

**UNIVERSAL TEST CLIPS**

**No. 45 Pee Wee**

A small test clip for radio, ignition, meter and similar work. Jaws have meshing teeth.

Interlocking necks.

Steel, cadmium-plated, with screw.

Capacity, 5 amperes; length, 1½ inches; jaw spread, ½ inch; 7-pound spring.

Shipping weight per 100, 1¼ lb. Stock No. (892180)



**No. 48-B**

A small test and battery clip for radio use and general testing purposes. Also used as standard equipment on ignition test sets, soldering irons, electroplating racks, etc. Jaws have meshing teeth.

Steel, cadmium-plated, with screw. Capacity, 10 amperes; length, 2 inches; jaw spread, ⅞ inch; 10-pound spring.

Shipping weight per 100, 2 pounds. Stock No. (892184)



**RELIABLE TESTING CLIPS**

Reliable Testing Clips are used for temporary connections to insulated wires and are equipped with hard, sharp insulation puncturing points and perfectly registering teeth.



Cat. No.	Stock No.	Description	Std. Pkg.	Ship. Wt. Lbs per C
1	(892188)	Fitted with screw, nut, washer and spike. (As illustrated)	100	3
2	(892189)	Fitted with Spike only	100	3
3	(892190)	Fitted with screw, nut and washer	100	3



Cat. No.	Stock No.	Description	Std. Pkg.	Ship. Wt. Lbs per C
5	(892191)	As shown in lower illustration	100	1

**NO. 18 MILONITE OR PERFECTION INSULATED NAILS**

Recommended for installing two-conductor or three-conductor twisted insulated wire.

They are easy to handle and install and prevent short circuiting.

Furnished in olive green, dark brown and ivory.

Length Inches	Stock No.
½	(893067)
⅝	(893068)
⅞	(893069)



**WASHER TYPE TELEPHONE WIRING NAILS**

The head is steel drawn over a specially prepared tough fibre in such a way that a washer is formed below the steel. Insulation is assured.

Waterproof and dielectric finish. Furnished in sizes ½ and ⅞ inches, and in white, ivory or any standard color.

Packed 100 in a box.

Length Inches	Stock No.
½	(893076)
⅞	(893077)



**METAL INSIDE WIRING NAILS**

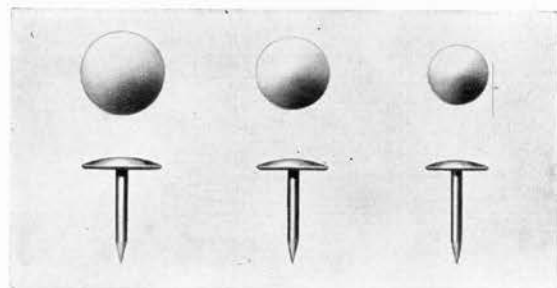

No. 555      No. 333      No. 222

Furnished in brown, green and black.

Packed 100 in a package.

Length Inches	Head Dia.	Cat. No. 555		Cat. No. 333		Cat. No. 222	
		Stock No.	Head Dia.	Stock No.	Head Dia.	Stock No.	Head Dia.
½	7/16	(893058)	⅜	(893061)	23/64	(893064)	
⅝	7/16	(893059)	⅜	(893062)	23/64	(893065)	
⅞	7/16	(893060)	⅜	(893063)	23/64	(893066)	

**BLAKE INSULATED STAPLES**

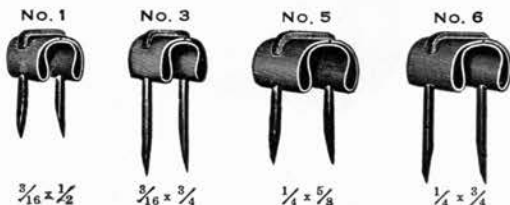

⅜ x ½

⅜ x ¼

¼ x ⅝

¼ x ¾

Cuts are actual size.

Packed 100 to a box; 1000 to a carton.

Catalog No.	Stock No.
1	(893070)
3	(893071)
5	(893072)
6	(893073)

## MANSON FRICTION TAPE



Made only with new rubber which thoroughly impregnates and coats the strong, closely woven cotton fabric.

Unequaled in true adhesiveness and in aging and weathering qualities.

Provides lasting protection for joint.

Rolls, 3/4 in. wide, containing 75 feet, black, per lb. (in cans).  
Stock No. (890753)

## OKONITE RUBBER TAPE



Compounded only from new Up-River fine Para rubber. When wrapped on the joint, it fuses into a homogeneous wall of tough insulation that is impervious to moisture and stays elastic and resilient.

Insures highest electrical strength and permanence.

Rolls, 3/4 in. wide, containing 30 feet, black, per lb. (in cans).  
Stock No. (890755)

## OKOPRENE WEATHER RESISTANT TAPE



Okoprene Weather Resistant Tape provides permanent, non-fibrous protection for all splices in neoprene-sheathed cables. Made with neoprene, it possesses unsurpassed resistance to ozone and weather and excellent all-round physical properties.

Okoprene Tape fuses into a tough waterproof sheath which provides additional electrical insulation as well as permanent mechanical protection. Any need for friction tape coverings or weather-proof paint is thus eliminated.

Okoprene Tape Packing: Standard package is 3/4" width, 1/2 lb. roll, packed in blue metal cans. Others are wrapped in cellophane or waxed paper.

Stock No. (894841)

## NO. 33 SCOTCH ELECTRICAL TAPE With Vinyl Plastic Backing



This tape has a stretchy, rubber-like Vinyl Plastic backing that enables it to do the work of the rubber and friction tape combination. Goes on in one operation, instead of two, and does a better job. Its stretchability and resistance to oil and moisture equip it perfectly for a wide range of uses in electrical construction and repair. Its thinness gives it an important advantage in "over-stuffed" junction boxes.

Cat. No.	Stock No.	Dimensions	Packing	
			Can	Carton
33	(894837)	3/4" x 72"	1	12

STROMBERG-CARLSON

**RUBEROID INSULATING TAPE**

**Asphalt Saturated**



A tough, waterproof insulating tape, both sides adhesive. For use both above and below ground. Has great tensile strength, won't tear, ravel or pucker; resists abrasion and is acid or alkali proof. Will not dry, crack or harden and is especially durable. Adapted for wires, connections, conduit joints, overhead cables, mine machinery and mine locomotive cables,

telephone and electric light lines. May be stored without deterioration.

Exceeds A.S.T.M. specifications by 300% in adhesiveness, 26% in tensile strength and 290% in dielectric strength.

Width In.	Stock No.	Weight per roll	Approx. Ft. per roll
3/4	(894196)	1/2 lb.	61 2/3
2	(894197)	1 lb.	46 1/4

Standard cases of 3/4" contain 25 lbs.

Standard cases of 2" contain 50 lbs.

**NO. 1501 A.S.T.M. FRICTION TAPE**



SI Brand Friction Tape is made of a strong closely woven cotton fabric which is thoroughly saturated with an adhesive insulating compound that retains its sticking qualities through all seasons.

82 1/2 feet minimum per roll. Supplied in 3/4-inch and 2-inch widths.

Width In.	Stock No.
3/4	(890751)
2	(890752)

**DIAMOND DHD HAMMER DRIVE ANCHORS**

For nailing to concrete, brick or stone. Shields are non-rusting, of aluminum alloy; made of one-piece of metal, a single unit which cannot become disarranged.

Furnished with heavily galvanized nails.



Diam. and Lgh. of Shield Inches	Stock No.	Diam. Drill to Use inches	Aver. Load Sustained Lb.	Working Load Lb.	Std. Pkg.	Wt. Lb. per 100
3/16x7/8	(890125)	3/16	500	100	100	1
3/16x1 1/4	(890126)	3/16	650	130	100	1 1/4
1/4 x 1	(890127)	1/4	1200	240	100	1 1/2
1/4 x 1 1/4	(890128)	1/4	1300	260	100	1 3/4
1/4 x 1 1/2	(890129)	1/4	1400	280	100	2 1/4
5/16 x 1 1/4	(890130)	5/16	1450	290	100	2 3/4
5/16 x 1 3/4	(890131)	5/16	1500	300	100	3 1/2
5/16 x 2 1/4	(890132)	5/16	1750	350	100	4 1/2
5/16 x 2 3/4	(890133)	5/16	1750	350	100	5
3/8 x 2	(890134)	3/8	2000	400	100	6 1/2
3/8 x 3 1/4	(890135)	3/8	2000	400	100	8 1/4
1/2 x 2 1/4	(890136)	1/2	3000	600	50	11 1/2
1/2 x 3 1/2	(890137)	1/2	4000	800	50	15 1/2

**DIAMOND DRIVE RINGS**



This ring accomplishes the same purpose as the screw threaded pigtail bridle ring, but is designed for driving instead of screwing into structures. When attached to hard substances, brick, stone or concrete, hammer drive anchors are employed.

Made of hard nail wire, hot dip galvanized.

Stock No.	(893078)	(893079)	(893080)
Diameter Eye	1/2 in.	5/8 in.	7/8 in.
Size Hammer Drive Anchor to Use	in. 3/16 x 7/8	1/4 x 1	1/4 x 1
Weight per 1000	lb. 16	28	53

**LAG SCREW EXPANSION SHIELDS**



Made of high grade ductile malleable iron. Use with cut or rolled thread lag screws.

The misfit thread problem has been solved by the improved formation of the interior threaded portion in the Lag Screw Shield. They will permit cut thread and rolled thread, cone point and gimlet point lag screws of good and poor quality, to enter equally well with a free and uniform expansion and without binding.

The inner-end parallel expansion gives increased holding power. The circular ribs increase the holding power, and the parallel ribs prevent the shield turning in the wall.

The Diamond P has the four-way expansion at the inner end.

**Long Standard**

Diameter Screw In.	Stock No.	O.D. & Drill Size In.	Length of Shield In.	Wt. Lb. per 100
1/4	(890117)	1/2	1 1/2	5
5/16	(890118)	9/16	1 3/4	6
3/8	(890119)	5/8	2 3/4	12
1/2	(890120)	3/4	3 1/2	20

**Short Standard**

1/4	(890121)	7/16	1	3
5/16	(890122)	1/2	1	4
3/8	(890123)	5/8	2	9
1/2	(890124)	3/4	2	13

**BRIDLE RINGS**

**Galvanized and Enameled**

For pole and line interior block distribution.

Furnished either galvanized by the hot process or enameled. All enameled rings, unless otherwise specified, are furnished in dark blue. Opening of all rings is 5/16 inches.

Style	Stock No.		Eye In.	Shank In.	Steel In.	Lbs. per 1000 Galvan.	Lbs. per 1000 Enam.
A	(893053)	(894161)	1 5/8	1 1/4	1/4	115	150
C	(893054)	(894162)	1 1/4	1 1/4	1/4	95	125
E	(893055)	(894163)	5/8	7/8	3/16	35	50
F	(893056)	(894164)	3	1 7/8	5/16	300	335

## MULTI-SIZE SCREW ANCHORS



Multi-size Screw Anchors are designed to accommodate in one anchor several diameters of wood screws. The purpose is to reduce the number of anchors required to accommodate all sizes of screws. They are made in several lengths covering the majority of uses. For instance, the No. 10 to 14 x 1-inch anchor will work successfully with all sizes of wood screws ranging from No. 10 to No. 14 inclusive.

The high projecting interior ribs support and centrally locate a small No. 10 wood screw causing the shield to expand and giving ample holding capacity for that size of screw.

In this same size of anchor larger screws up to and including No. 14 may be used equally well. This is accomplished by the flexible interior ribbing.

Where the larger screw is used, the ribs are pressed down and the valleys at the exterior are forced outward to permit the greater diameter of the screw to enter the shield. The improved Multi-Size Screw Anchor has two advantages over the original Multi-Size; the screw enters the shield more easily without danger of marring the head of the screw and relieves the strain applied to the screw when inserted. It will also sustain a greater load.

Packed 100 to a box.

Designating Sizes	Stock No.	For Wood Screws No.	Lgth. In.	Drill Size In.	Wt. Lb. per C
Nos. 6 to 8 x 3/4"	(890113)	6 to 8	3/4	1/4	1
Nos. 10 to 14 x 1"	(890114)	10 to 14	1	5/16	2
Nos. 10 to 14 x 1 1/2"	(890115)	10 to 14	1 1/2	5/16	2 3/4
Nos. 16 to 18 x 1 1/2"	(890116)	16 to 18	1 1/2	3/8	4 1/4

## DIAMOND STRAND CONNECTOR



Diamond Strand Connectors are designed for connecting up dead ends of messenger strands when they occur between poles. With this strand connector the wire strands are looped in opposite directions and held with guy clamps.

The improved design will accommodate up to 25,000 lb. strand. The enlarged oval-shaped holes facilitate threading strand through the connector. The larger body diameter around which the strand is looped in the connector distributes pressure over more of the strand.

The deeper grooves follow a smooth continuous arc forming a perfect seat for the strand, thus eliminating wear from vibration.

Net weight each, 1 lb.

Catalog No. 867 Stock No. (893405)

## TOGGLE BOLTS



No. 1



Spring



No. 5

For making attachments to hollow brick, tile or lath walls.

The Diamond Spring Toggle is made with two wings that engage a trunnion nut and a spring which forces the wings outward when the head has passed through the wall.

The No. 1 Diamond Toggle Bolt has the threaded bolt riveted to the toggle head.

On the No. 5 Diamond Toggle Bolt a swivel nut is provided in the toggle head which permits a stove bolt being screwed in with a finished head at the outside of the work. Furnished with either round or flat slotted head.

Bolt Size Inches Diam.	Inches Lgth.	Stock No.	Drill Size Inches Spring and Cat. No. 5	Cat. No. 1
1/8	2	(890138)	3/8	1/4
1/8	3	(890139)	3/8	1/4
1/8	4	(890140)	3/8	1/4
3/16	2	(890141)	1/2	3/8
3/16	3	(890142)	1/2	3/8
3/16	4	(890143)	1/2	3/8
3/16	5	(890144)	1/2	3/8
3/16	6	(890145)	1/2	3/8
1/4	3	(890146)	11/16	7/16
1/4	4	(890147)	11/16	7/16
1/4	5	(890148)	11/16	7/16
1/4	6	(890149)	11/16	7/16

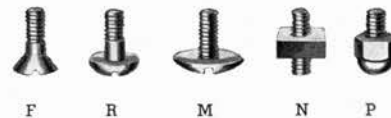

- F With flat head screw
  - R With round head screw
  - M With mushroom head, 1/8 inch diameter only
  - N Reverse R or F screw and add nut
  - P Reverse R or F screw and add acorn nut
- Furnished in steel or brass.

**NO. 5500 SPRINGIN TOGGLE BOLTS**

R With round head screw.  
 F With flat head screw.  
 M Mushroom head, furnished in R type, 1/8-inch diameter only.  
 N Reverse R or F screw and add nut any size.  
 P Plumbers' Toggle—Reverse R or F screw and add nut on any size.  
 Resilient wings are tempered spring steel with a cam action against saddle which throws them to open position.



**With R, F, N or P Head Screws**

5510	(890161)	3/16x3	1/2	50	3
5511	(890162)	3/16x4	1/2	50	4
5512	(890163)	3/16x5	1/2	50	5
5513	(890164)	3/16x6	1/2	50	5 1/2
5515	(890165)	1/4x3	5/8	50	6
5516	(890166)	1/4x4	5/8	50	7
5517	(890167)	1/4x5	5/8	50	8
5518	(890168)	1/4x6	5/8	50	9 1/2
5520	(890169)	5/16x3	7/8	50	10
5521	(890170)	5/16x4	7/8	50	12
5523	(890171)	5/16x6	7/8	50	15
5525	(890172)	3/8x3	7/8	50	13
5526	(890173)	3/8x4	7/8	50	15 1/2
5528	(890174)	3/8x6	7/8	50	21

Threads are National Standard, not stove bolt threads.

**With F or M Head Screws**

Cat. No.	Stock No.	Diam. and Length of Screw, In.	Size Drill Required Inches	Number Pieces in Box	Ship. Wt. Lb. per 100
5506	(890158)	1/8x2	3/8	100	1 1/2
5507	(890159)	1/8x3	3/8	100	1 3/4
5508	(890160)	1/8x4	3/8	100	2

**With R or N Head Screws**

5536	(890175)	1/2x4	1 1/8	25	27
5538	(890176)	1/2x6	1 1/8	25	36

**COMMON NAILS AND SPIKES**  
 Hot Galvanized



Flat reinforced head diamond pointed nails heavily galvanized can be supplied in sizes from 2d to 60d. Following sizes more generally used in telephone work.

**Following Sizes Recommended**

Size No.	Stock No.	Length In.	Gage No.	Approx. No. per Keg
6d	(893621)	2	11 1/2	17400
8d	(893622)	2 1/2	10 1/4	10600
10d	(893623)	3	9	6900
20d	(893624)	4	6	3100
30d	(893625)	4 1/2	5	2400
40d	(893626)	5	4	1800
50d	(893627)	5 1/2	3	1400
60d	(893628)	6	2	1100
*60d	(893629)	3 1/2	1	—

\*Stub spike. Not standard.

**Recommended Uses**

Size No.	Use
6d	Nailing Pins to Crossarm
8d	General Purposes
10d	Fastening Strain Plates
20d	Lower Nail Fastening No. 1 Brackets
30d	Lower Nail Fastening W.U. and No. 2 Brackets
50d	Upper Nail Fastening No. 1 Brackets
60d	Upper Nail Fastening W.U. and No. 2 Brackets
30d	Lower Nail Fastening Pole Steps
60d	Upper Nail Fastening Pole Steps
60d	(3 1/2-inch Stub Spike) Used with Creosote Pine Poles

**GENERAL INDEX**

A complete alphabetical index with cross references for all the products shown in this section or any of the other sections will be found in the center of this catalog.

## IRON WOOD SCREWS

Screw Size	Length	Stock No.	Standard Flat	Heads Round	Specify Oval	Screw Size	Length	Stock No.	Standard Flat	Heads Round	Specify Oval
2	1/4	(893520)	x	x		9	1	(893568)	x	x	
2	3/8	(893521)	x	x		9	1 1/4	(893569)	x	x	
2	1/2	(893522)	x	x		9	1 1/2	(893570)	x	x	
2	3/8	(893523)	x	x		9	1 3/4	(893571)	x	x	
3	3/8	(893524)	x	x		9	2	(893572)	x	x	
3	1/2	(893525)	x	x		9	2 1/2	(893573)	x	x	
3	3/8	(893526)	x	x		10	3/4	(893574)	x	x	
4	1/4	(893527)	x	x		10	7/8	(893575)	x	x	
4	3/8	(893528)	x	x	x	10	1	(893576)	x	x	x
4	1/2	(893529)	x	x	x	10	1 1/4	(893577)	x	x	x
4	5/8	(893530)	x	x	x	10	1 1/2	(893578)	x	x	x
4	3/4	(893531)	x	x	x	10	1 3/4	(893579)	x	x	x
4	7/8	(893532)	x	x		10	2	(893580)	x	x	x
4	1	(893533)	x	x		10	2 1/4	(893581)	x	x	
4	1 1/4	(893534)	x	x		10	2 1/2	(893582)	x	x	
5	3/8	(893535)	x	x		10	3	(893583)	x	x	
5	1/2	(893536)	x	x	x	10	3 1/2	(893584)	x	x	
5	5/8	(893537)	x	x	x	12	3/4	(893585)	x	x	
5	3/4	(893538)	x	x	x	12	7/8	(893586)	x	x	
5	7/8	(893539)	x	x		12	1	(893587)	x	x	
5	1	(893540)	x	x	x	12	1 1/4	(893588)	x	x	x
5	1 1/4	(893541)	x	x		12	1 1/2	(893589)	x	x	x
6	3/8	(893542)	x	x	x	12	1 3/4	(893590)	x	x	x
6	1/2	(893543)	x	x	x	12	2	(893591)	x	x	x
6	5/8	(893544)	x	x	x	12	2 1/4	(893592)	x	x	
6	3/4	(893545)	x	x	x	12	2 1/2	(893593)	x	x	
6	7/8	(893546)	x	x	x	12	3	(893594)	x	x	
6	1	(893547)	x	x	x	12	3 1/2	(893595)	x	x	
6	1 1/4	(893548)	x	x	x	14	1	(893596)	x	x	
6	1 1/2	(893549)	x	x	x	14	1 1/4	(893597)	x	x	
7	1/2	(893550)	x	x		14	1 1/2	(893598)	x	x	
7	3/8	(893551)	x	x		14	1 3/4	(893599)	x	x	
7	3/4	(893552)	x	x	x	14	2	(893600)	x	x	
7	7/8	(893553)	x	x		14	2 1/4	(893601)	x	x	
7	1	(893554)	x	x	x	14	2 1/2	(893602)	x	x	
7	1 1/4	(893555)	x	x	x	14	3	(893603)	x	x	
7	1 1/2	(893556)	x	x	x	14	3 1/2	(893604)	x	x	
8	1/2	(893557)	x	x		14	4	(893605)	x	x	
8	3/8	(893558)	x	x	x	16	1 1/4	(893607)	x	x	
8	3/4	(893559)	x	x	x	16	1 1/2	(893608)	x	x	
8	7/8	(893560)	x	x	x	16	1 3/4	(893609)	x	x	
8	1	(893561)	x	x	x	16	2	(893610)	x	x	
8	1 1/4	(893562)	x	x	x	16	2 1/2	(893611)	x	x	
8	1 1/2	(893563)	x	x	x	16	3	(893612)	x	x	
8	1 3/4	(893564)	x	x		16	3 1/2	(893613)	x	x	
8	2	(893565)	x	x		16	4	(893614)	x	x	
8	2 1/2	(894177)	x	x		18	1 1/2	(893615)	x	x	
9	3/4	(893566)	x	x		18	2	(893616)	x	x	
9	7/8	(893567)	x	x		18	2 1/2	(893617)	x	x	
						18	3	(893618)	x	x	
						18	3 1/2	(893619)	x	x	
						18	4	(893620)	x	x	

Lengths and Diameters not listed can be furnished on special order when quantities are sufficient to warrant a special run. Phillips Recessed Head Wood Screws are also available on special order.

**ELECTROX RECTIFIERS**  
**For Operating Telephone Systems**  
**without Batteries**

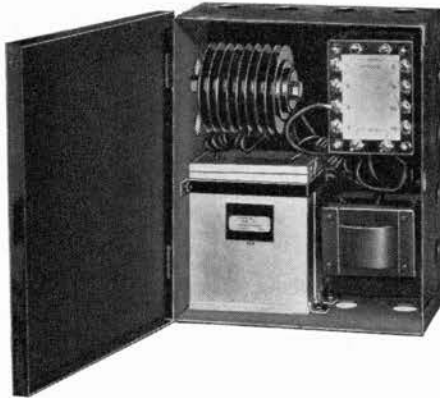

Type A For Small Systems

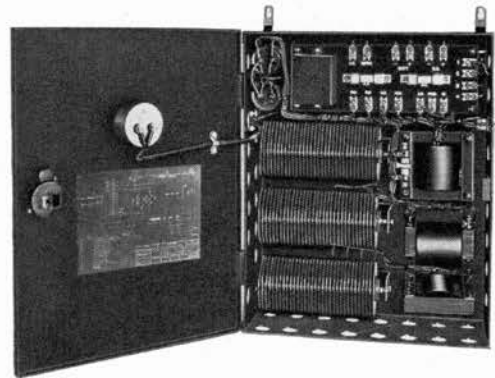

Type RA For Lamp Signal and Automatic Switchboards

Electrox Rectifiers are especially designed for supplying direct current to small common battery and intercommunicating systems without the use of batteries.

These units operate from 110 Volt 60 Cycle alternating current which is first passed through a suitable transformer by means of which the proper voltage is maintained for operating the rectifier unit. This alternating current, at the proper voltage, is then converted to direct current by a full wave dry disc rectifier of the copper oxide or Selenium type. The direct current is further

smoothed at this stage by an ample choke and condenser filtering network which eliminates hum and interference in the operation of telephone equipment.

Electrox Rectifiers (Battery Eliminators) are available in three general types—"A," "AJ" and "RA." All parts are housed in a ventilated steel cabinet arranged for wall mounting. The equipment also includes a rubber covered attachment cord and plug.

Standard output voltages and current values for these types are as follows:

**Type A—With Housing**

For Intercommunicating and Common Battery Systems without Lamp Signals

Type No.	Stock No.	D.C. Output		*Ringing	Size
		Volts	Amps	Volts	(Inches)
A-05008	(894344)	6-8	0.5	6-12-18	5x8x5½
A-1008	(894345)	6-8	1.0	6-12-18	8x10x6
A-05012	(894346)	12	0.5	6-12-18	8x10x6
A-1012	(894347)	12	1.0	6-12-18	8x10x6
A-2012	(894348)	12	2.0	6-12-18	10x12x6
A-05024	(894349)	24	0.5	12-18-24	10x12x6
A-1024	(894350)	24	1.0	6-12-18-24	10x12x6
A-2024	(894351)	24	2.0	6-12-18-24	10x12x6

\* Supplied only when specified on order.

**Type AJ—Less Housing**

Type AJ Rectifiers have the same equipment as Type A but are mounted on a steel base without a housing.

**Type RA—Battery Eliminator With Housing**

Type No.	Stock No.	D.C. Output		*Ringing	Size
		Volts	Amps	Volts	(Inches)
RA-1012	(894352)	12	1.0	6-12-18	10x12x6
RA-2012	(894353)	12	2.0	6-12-18	10x12x6
RA-05024	(894354)	24	0.5	12-18-24	10x12x6
RA-1024	(894355)	24	1.0	6-12-18-24	10x12x6
RA-2024	(894356)	24	2.0	—————	12x15x7
RA-3024	(894357)	24	3.0	—————	12x15x7
RA-4024	(894358)	24	4.0	—————	12x18x7
RA-2048	(894359)	48	2.0	—————	12x18x7
RA-3048	(894360)	48	3.0	—————	16x18x7
RA-4048	(894361)	48	4.0	—————	16x18x7

\* Supplied only when specified on order.

**No. 6001 Impedance Unit**

For use with types A-05004 and PA-05004 Battery Eliminator to avoid cross talk when used to supply two or more operators' positions on magneto switchboards.

Catalog No. 6001 Stock No. (894362)