

500 SERIES COMBINED TELEPHONE SETS

GENERAL DESCRIPTION

<u>CONTENTS</u>	<u>PAGE</u>
1. GENERAL . . . . .	1
2. DESIGN OBJECTIVES . . . . .	1
3. GENERAL FEATURES . . . . .	2
4. COMPONENT DESIGN AND PERFORMANCE . .	2
(A) Hand Set . . . . .	2
(B) Transmitter . . . . .	4
(C) Receiver . . . . .	5
(D) Dial . . . . .	6
(E) Ringer . . . . .	6
(F) Network . . . . .	7
(G) Equalizer . . . . .	8
5. NOISE, CROSSTALK AND SIDETONE CONSIDERATIONS . . . . .	8

2. DESIGN OBJECTIVES

2.01 In the design and development of the 500 series combined telephone sets, the general objectives were improvements in transmission and mechanical performances, appearance and convenience to the customer and a reduction in installation and maintenance effort.

2.02 In order to achieve these objectives most effectively, a completely new and integrated design was required. It became evident that a set capable of meeting a wider variety of field conditions was highly desirable in order to reduce the number of codes, thereby holding down manufacturing and administrative complexities and costs.

2.03 The primary transmission objective was to realize gains on long loops of about 5 db both transmitting and receiving and to improve the frequency response. Such gains would provide satisfactory transmission performance at greater distances from the central office or with the finer gauge conductors which are being placed to take advantage of the increases provided in central office equipment ranges. In order to attain these gains and at the same time produce a set which could be used on any length loop or any central office battery supply circuit, two major changes were required. First, better sidetone balance had to be attained in order to offset increased sidetone due to the gains in transmitter and receiver efficiencies. Second, some means had to be found, preferably automatic in operation, to keep the speech volume and receiving efficiency on short loops down to values no higher than those of the existing FLA-AST sets, since these values were about as high as could be used without introducing noise and crosstalk problems. Such a gain control would have the additional advantage of reducing the transmission differences experienced between short and long loops.

2.04 Other specific objectives were: a smaller hand set of lighter weight; a dial easier to see and to operate and with better pulse regulation; and a ringer with a higher acoustic output, more pleasing sound and a means for limited adjustment of its loudness by the subscriber. Furthermore, it was necessary that the set be compatible with existing plant equipment and operating conditions.

1. GENERAL

1.01 This section describes the 500 series combined telephone sets and discusses the design objectives of their development, their mechanical, electrical and transmission features and the noise crosstalk and sidetone considerations in design and performance.

1.02 From the standpoint of transmission the 500 series sets may be divided into three general types whose over-all performances differ because of circuit and component changes. These general types are (1) those which contain the tungsten filament-thermistor bead type equalizer as a separate component, (2) those from which equalizers were omitted and (3) those containing varistor-type equalizer elements as integral parts of the transmission network. The discussion in this subdivision of the section will be confined in so far as possible to the features and characteristics which are common to all sets in the 500 series. Other subdivisions will describe the over-all transmission characteristics, circuit details and set unbalances as they apply to the different types.

2.05 The manner in which these objectives were attained is discussed in detail in the parts of this section which describe the set and its components.

### 3. GENERAL FEATURES

3.01 Figs. 1 and 2 show the 500 series set to be of completely new form, both inside and out. The general dimensions were fixed largely by functional requirements. In comparison to its predecessor, the set weighs about half a pound more. It is lower and about an inch longer but is about the same width. The dial face is more nearly horizontal and the characters are outside the periphery of the finger-wheel. Among the advantages of these two features are greater visibility of the characters over wider angles of vision with no interference from the rotating finger-wheel and freedom from the wear and scratching which occurs to characters on the surface under the finger-wheel. The number plate, which is a part of the dial assembly, is made of black plastic with white characters molded in from the back. Thus the characters have a high degree of visibility and are not subject to wear. Small dots under the center of the finger-wheel holes serve as visual focus points and aid in reducing dialing time.

3.02 The housing serves only as a cover and as a cradle for the hand set and has no components attached to it other than the switch plungers. As shown in Fig. 2 all other component parts are mounted on the base plate with means provided for attaching and terminating the cords, ringer and dial leads, and other wiring. This feature facilitates both production assembly and testing as well as maintenance and installation since the set functions completely with the cover removed. Removal and replacement of the dial, ringer, hand set and cords may be made in the field. The switch assembly and transmission components are completely enclosed and protected, are permanently mounted in the base and are replaceable only in the shop.

3.03 Fig. 3 shows a 500 series set which includes a cold cathode tube in the ringer circuit.

### 4. COMPONENT DESIGN AND PERFORMANCE

#### (A) Hand Set

4.01 The G-type hand set illustrated in Fig. 4 is of new form and weighs 12 ounces, or 4 ounces less than the F-type. The length between transmitter and receiver is about 1/2 inch less than in the F-type and because of the



Fig. 1 - 500-Type Telephone Set

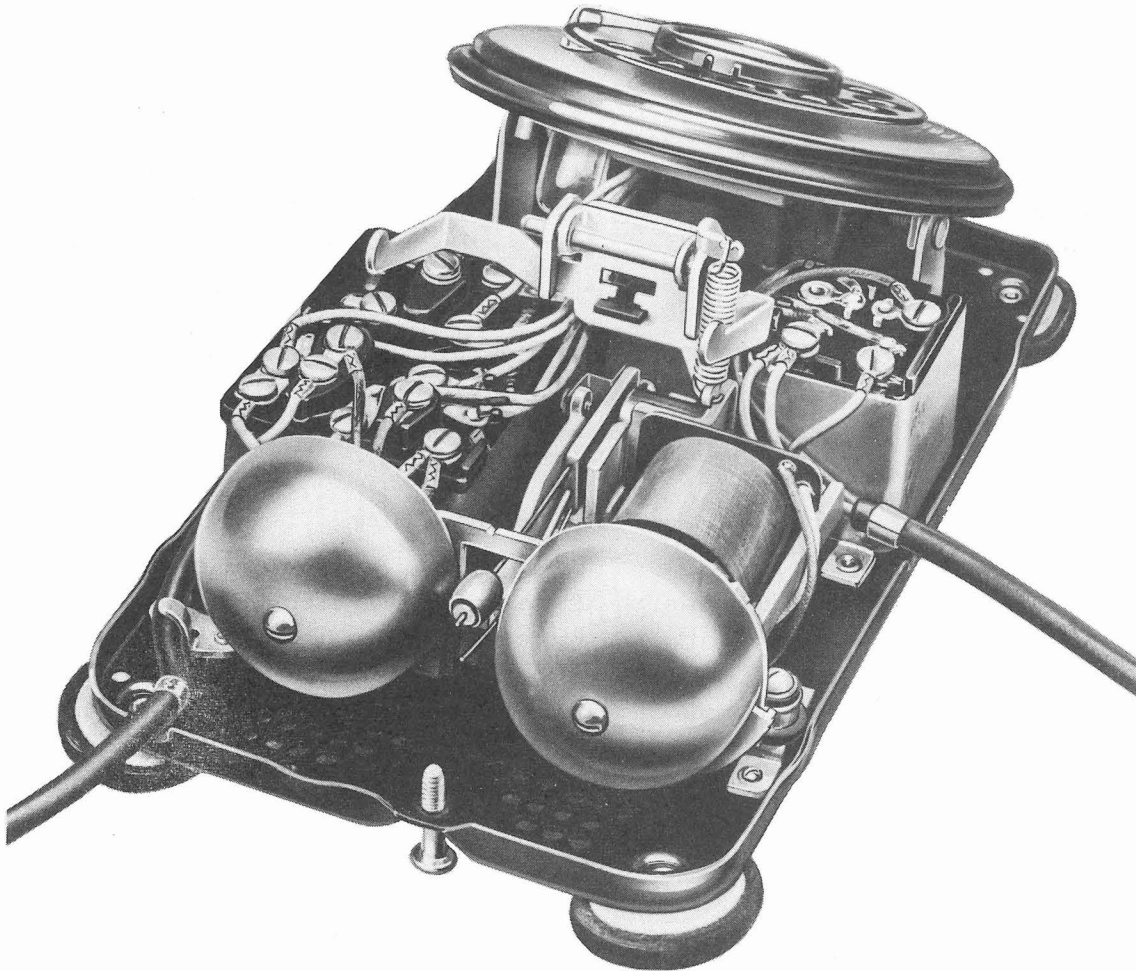

Fig. 2 - 500B-3 Telephone Set - Cover Removed

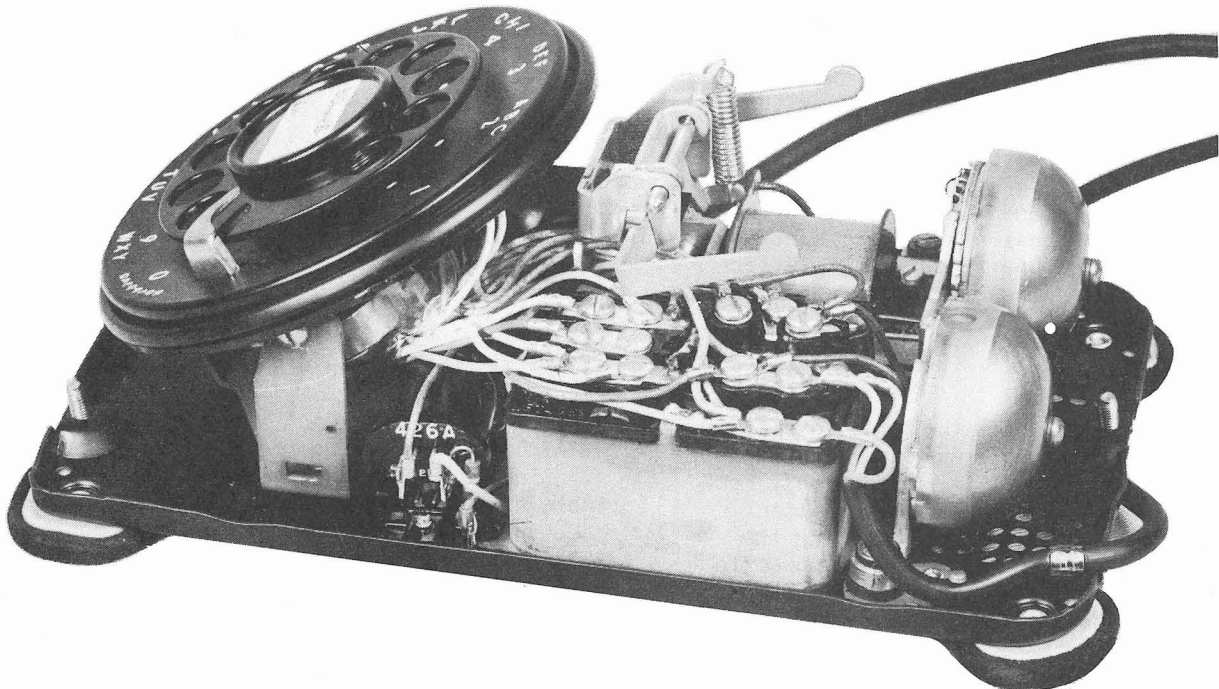

Fig. 3 - 501D-3 Telephone Set - Interior View Showing Location of Tube

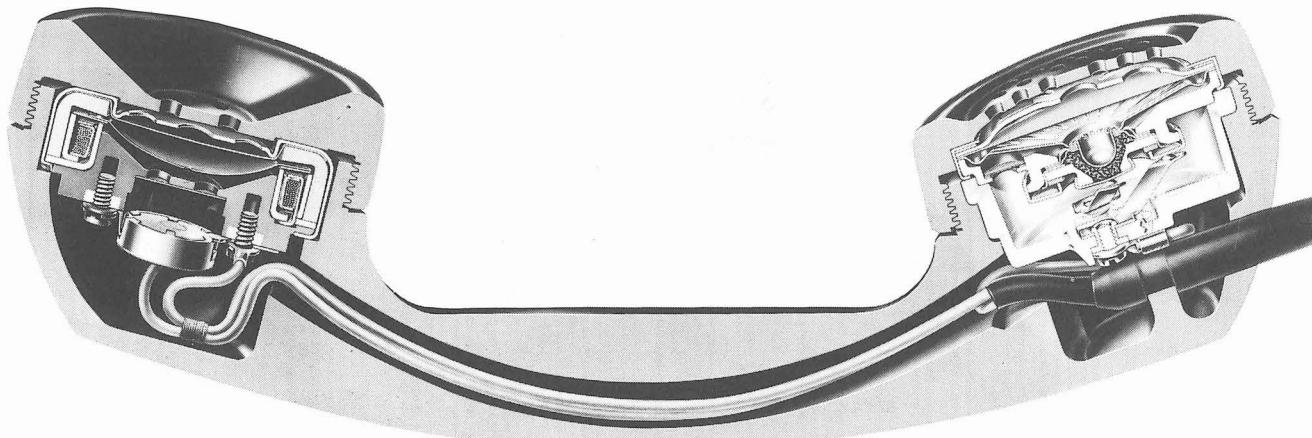

Fig. 4 - G1 Hand Set - Sectional View

size and shape a better average fit for the distribution of head sizes is provided. This results in a 2 to 3 db transmitting gain due to a higher average acoustic input to the transmitter which increases the modulation and, therefore, the output. The hand set is made of phenol plastic with a molded-in cavity through the handle serving as a conduit for the receiver conductors which extend directly from the cord to screw terminals on the back of the receiver. Contact to the transmitter terminals is through spring contacts mounted in a separate plastic cup which is the transmitter receptacle. The plastic cup also serves as a controlled acoustic cavity for the transmitter as well as acoustic isolation between transmitter and receiver. Four conductors are provided in the cord to separate the transmitter and receiver circuits which permits silencing of the receiver during dialing and switch operation by shorting rather than opening the receiver circuit as in the past. This has the double advantage of preventing out-of-service conditions due to dirty contacts, and extending cord life from the standpoint of noise by keeping d-c out of the receiver conductors, thus making the anti-sidetone feature fully effective in minimizing noise originating in the transmitter conductors.

#### (B) Transmitter

4.02 The transmitter, coded T1, while similar in structural design to the F1, differs in many important details. As previously mentioned, about half of the 5 db transmitting gain desired was achieved by shortening the hand set to deliver greater acoustic power to the transmitter. The other half was obtained by increasing both the modulating efficiency of the transmitter and its low-frequency response. Fig. 5 is a cross-sectional view of the T1

transmitter in the G1 handle. Modulation efficiency has been increased by changes in the size, shape and spacing of the electrodes and in the volume of the carbon chamber. In addition, the size and weight of the unit have been reduced. Stabilizing or "preaging" of the carbon granules during manufacture prevents the wide increase in resistance experienced in previous transmitters due to age and shock.

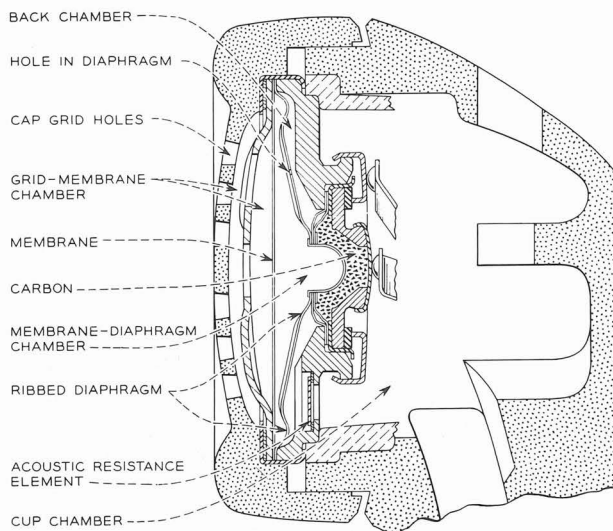

Fig. 5 - T1 Transmitter - Sectional View in G1 Hand Set

4.03 Improvement in the response characteristic was required to more nearly approach orthotelephonic transmission, that is, the speech quality which results when two people talk across a desk, sometimes called "1-meter speech." Measurements have shown that orthotelephonic speech has a rising frequency characteristic which peaks at about 3000 cps. For this reason, the response of the T1 transmitter

was designed to have such a characteristic. Since circuit losses usually increase with frequency, particularly those of non-loaded cable, partial frequency equalization is also attained. This response characteristic in the T1 transmitter was achieved by redesign of the diaphragm assembly and acoustic network. The diaphragm is clamped rigidly at its periphery and acoustic resistance, or damping, is provided to control its response. This is accomplished by coupling the diaphragm to a doubly resonant system composed of the cavity behind the diaphragm within the unit and the chamber enclosed by the plastic mounting cup. These two cavities are connected by holes in the frame of the unit which are covered by fabric having a controlled resistance to the flow of air. Careful design and proper acoustic balance have resulted in a transmitter having a uniformly rising output with frequency to about 2500 cycles, followed by a broad maximum output region extending to approximately 3500 cycles. Fig. 6 shows the response of the T1 transmitter compared to that of the F1 and includes the effect of the shorter G1 hand set. The high-frequency range of the T1 is about 500 cycles greater than that of the F1. The curves in Fig. 6 are for typical new transmitter units. Aging and differences in units will result in departures from these curves, but they serve to represent generally the response and volume improvements of the T1 transmitter over the F1.

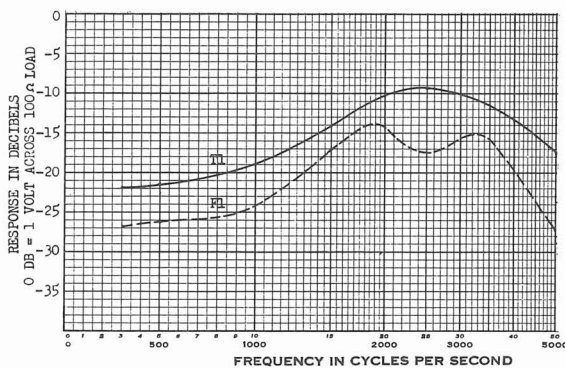

Fig. 6 - Frequency Response of T1 and F1 Transmitters Measured in Standard Handles with Constant Sound Pressure Applied at Modal Distances

### (C) Receiver

4.04 The receiver unit, designated as the U1, is of completely new design as shown in Figs. 7 and 8. It is known as the "ring armature" receiver because the permanent magnet, the pole piece, and the diaphragm armature, are all ring shaped parts. The diaphragm is dome shaped of phenolic impregnated fabric and is

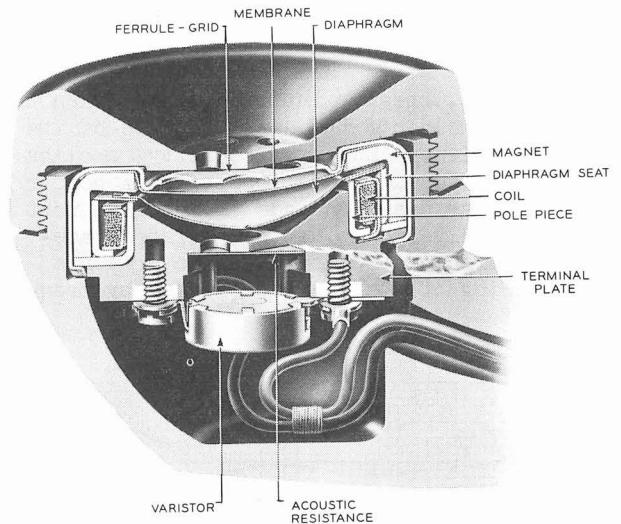

Fig. 7 - U1 Receiver - Sectional View in G1 Hand Set

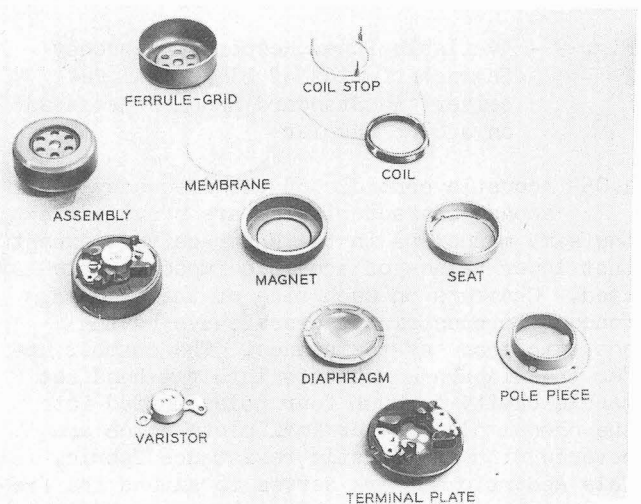

Fig. 8 - U1 Receiver Parts

cemented to the vanadium permendur armature ring. The outer edge of the armature ring rests on a circular seat of non-magnetic material and is driven at its inner edge by the magnetic field produced at the tip of the ring shaped pole piece. This design produces a much lighter structure with its mass concentrated in the outer metal ring and provides about a seven-to-one reduction in mechanical impedance with a correspondingly large increase in the ratio of effective mass to effective area. This in turn accounts for an average gain of 5 db and an extension of about 500 cycles in the frequency range over the HAL receiver, as shown in Fig. 9. Furthermore, because of the lower mechanical impedance of the diaphragm

system it is a better acoustic radiator, which results in less sensitivity to changes in coupling with the ear. This means better response and therefore, greater intelligibility when the receiver is held off the ear. Because of its higher efficiency and power capacity, a click reducer is used with this receiver. A copper oxide varistor has been made an integral part of the assembly and it not only affords adequate acoustic protection but also prevents demagnetizing of the receiver magnet by transient voltages.

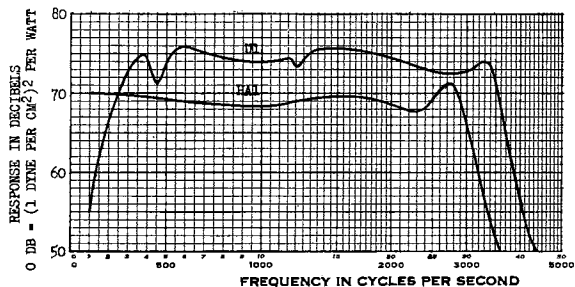

Fig. 9 - Available Power Response-Frequency Characteristics of UL and HAL Receivers in Standard Handles Measured on a 6 cc Coupler

4.05 Acoustic controls of the frequency response characteristics are provided in the same manner as in the HAL receiver, except that lower values of acoustic impedance are used. Chambers on each side of the diaphragm connect to constricted passageways having acoustic mass and resistance. The chamber under the diaphragm exhausts into the hand set handle cavity through four holes molded into the phenol plastic terminal plate which are covered with an acoustic resistance fabric. This acoustic network serves to extend the frequency range of the receiver because of its negative reactance characteristics and the acoustic resistance damps out the diaphragm resonance. The chamber above the diaphragm exhausts into the listener's ear cavity through the acoustic mass and resistance of the holes in the receiver cap. Proper selection of the acoustic impedances of the elements of this network further extends the frequency response. The relationships of all the acoustic and mechanical elements are such as to produce the desired response characteristic. The irregularities in the characteristic of the UL receiver at 450 and 1200 cycles are not inherent in the receiver but are acoustical effects of the conduit molded in the hand set handle. Since no adverse effect of these irregularities has been observed, it was not considered necessary to plug the receiver end of the conduit.

4.06 In order to reduce interference caused by low order harmonics of power frequencies induced into telephone circuits by a-c power lines, the receiver has been given a low-frequency cutoff below about 250 cps, as shown in Fig. 9. This was accomplished by punching a small hole in the center of the diaphragm. The diameter of the hole is such that the response at 180 cps is 10 db below the 1000 cps response.

4.07 Fig. 10 shows the impedance of the UL receiver measured on a closed chamber of 6 cc volume, which provides damping approximating that of the ear.

#### (D) Dial

4.08 The mechanism of the dial differs from that of its predecessors and incorporates improved performance and complete enclosure as a protection against dirt. Improved performance arises chiefly from the closer control realized both in manufacture and in service over the pulsing characteristics and speed regulation. By controlling the time of both the break and make of the pulsing contacts to narrower limits than in previous types, appreciable extension of dialing range has been attained. Tolerance of the per cent break has been reduced from  $\pm 4\%$  to  $\pm 2\%$ . Normal operating speed is controlled to  $10 \pm 0.5$  pulses per second instead of  $9.5 \pm 1$  as in previous types. The controlled speed is inherent in the design and manufacture and no means of field adjustment is provided.

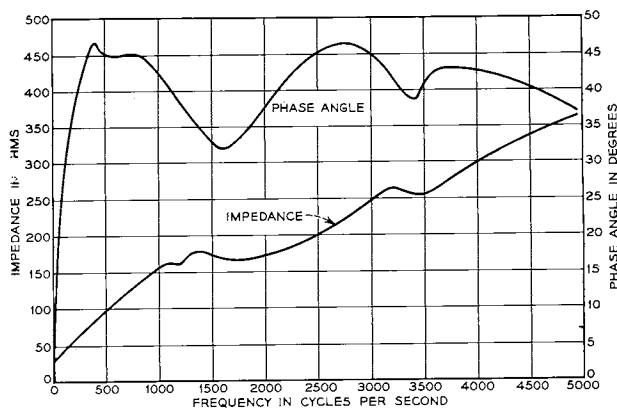

Fig. 10 - Impedance of UL Receiver

#### (E) Ringer

4.09 The ringer, illustrated in Fig. 12, is also of entirely new design. It uses a single coil with a laminated steel core rather than two coils. The single coil has two windings which permit use of the ringer on 2-party services requiring station identification as

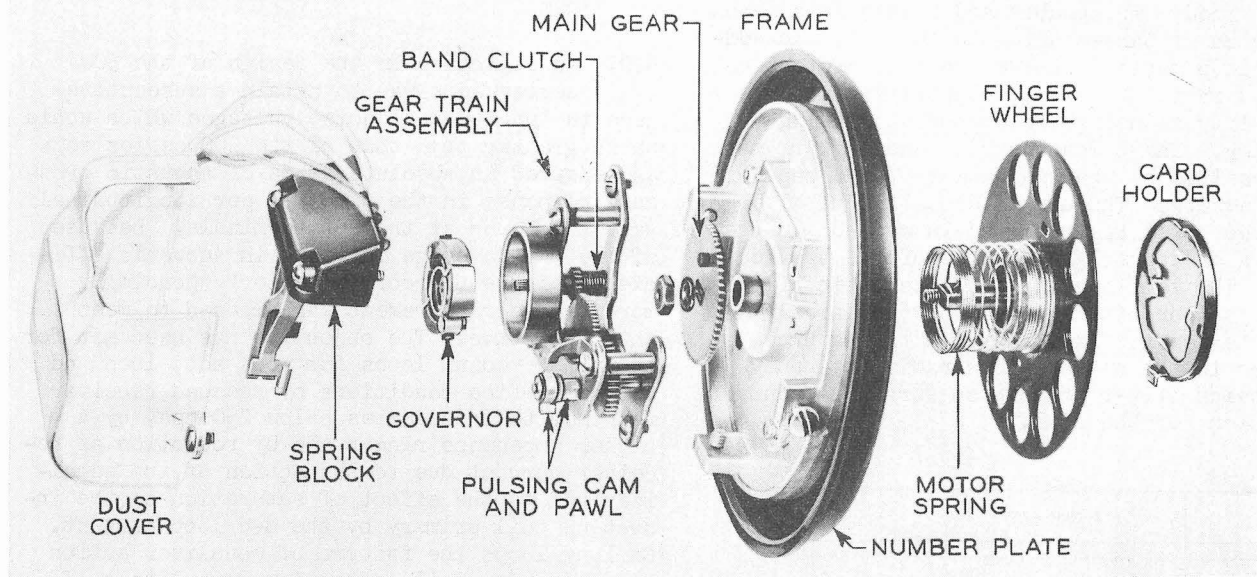

Fig. 11 - 7A-3 Dial

well as on general service. An important improvement is the ringer loudness control. A notched wheel extending through a slot in the base of the set may be rotated to four different positions corresponding to four levels of loudness over a range of approximately 15 db. This wheel simultaneously controls the armature stroke and the clearance between one gong and the clapper so that the force of the clapper striking the gongs changes with each position of the wheel. A mechanical stop is provided so that the subscriber can not reduce the volume below a predetermined level. The maximum sound output of the ringer is about 3 db higher than previous types due to higher magnetic efficiency and to built-in resonators. Only two bias adjustments are provided. The high notch is used for all services except where three or more ringers are bridged or where more than four are connected from the same side of the line to ground, in which cases the low notch is used.

4.10 The fundamental frequencies of the two gongs are lower and much more predominant than in earlier types. This has the dual advantage of producing a somewhat more pleasing tone which is also more audible to people whose hearing is deficient at the higher frequencies.

4.11 In addition to the desired operating characteristics such as adequate sensitivity and protection against bell tapping and cross ringing, the ringer has a higher impedance both at ringing and voice frequencies.

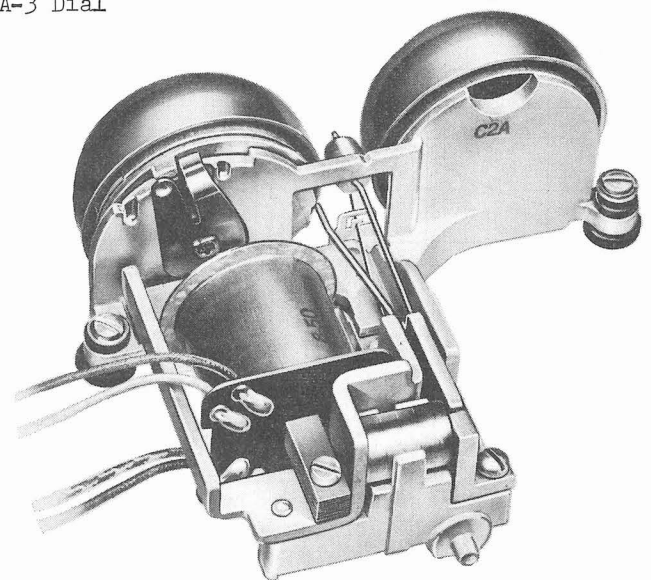

Fig. 12 - C2A Ringer

Fig. 13 shows the impedance characteristic of the C2A ringer compared to that of the BLA. The higher impedance at ringing frequency permits the use of five ringers, either bridged or between each wire and ground, instead of four as in the past. Higher voice-frequency impedance reduces the magnitude of longitudinal noise current.

#### (F) Network

4.12 The transmission network, which includes the elements of the basic telephone set circuit, is also of new design. All components

are compactly mounted on a common terminal plate, wired, impregnated and housed in a metal case which is base-mounted in the set. An added field benefit is the mechanical protection afforded by the housing, which eliminates the possibility of damage to components during servicing. The compactness of the network was made possible by the small size of the capacitor elements. The use of deposited metal on lacquered paper has resulted in dependable capacitors of about 1/4 the size of the previous types. The self-healing characteristic of this type capacitor after breakdown will largely eliminate service failures from this source. Included in the network is a radio frequency suppression filter which also serves as contact protection for the dial.

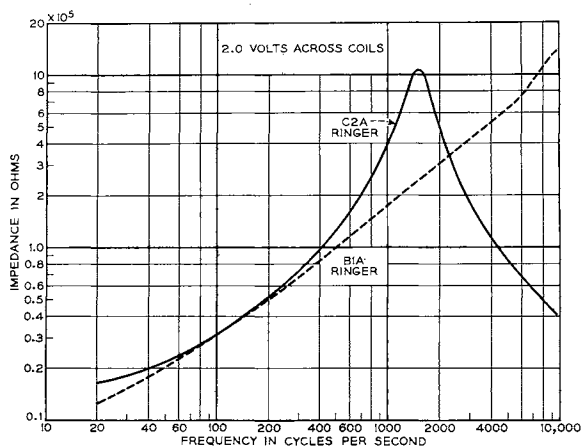

Fig. 13 - Impedance Characteristics of C2A and B1A Ringers

4.13 The network components and circuit arrangement differ between the earlier and later types of sets in the 500 series. These details and their transmission aspects will be discussed in the subdivisions of the section which relate to the particular types.

#### (G) Equalizer

4.14 As mentioned in Paragraph 2.03, an automatic means of volume control for both the transmitter and receiver was required in order to utilize the higher efficiencies of the units. This has been provided by two different methods; one in the earlier type set and another in the later type. As in the case of the networks these will be discussed in the appropriate subdivisions of the section.

## 5. NOISE, CROSSTALK AND SIDETONE CONSIDERATIONS

5.01 An objective in the design of the 500 series sets was to attain a susceptibility to longitudinal noise voltages which would be no greater than that of the 300 series sets as measured in absolute terms of acoustic pressure response in the receiver per longitudinal volt to ground at the set terminals. Because of the 5 db average increase in acoustic efficiency of the U1 receiver a correspondingly more severe requirement was imposed to meet this objective. The objective has been met for short and medium loops for most set, loop and central office conditions by reduced receiver response to frequencies below 250 cps, by a higher impedance ringer and by reduction of receiver current due to the action of the equalizer and to the effect of saturation of the induction coil primary by the d-c loop current. On long loops the factors of equalizer action and induction coil saturation have little effect and the full acoustic gain of the receiver is realized. Under this condition the 500 series sets do not meet the objective in terms of acoustic pressure over parts of the frequency range above 250 cps, even though the unbalance current through the receiver (in microamperes per longitudinal volt to ground) may be lower than in the 300 series sets. Below 250 cps the response of the U1 receiver is lower than that of the HAL, as indicated in Fig. 9. Thus the susceptibility of the 500 series sets is lower in this range than the 300 series under nearly all set and loop conditions. The effects of noise are discussed further in the subdivisions of the section dealing with specific types of sets. Data on the susceptibility of the 500 series sets will be found in the AB63 series of the practices.

5.02 Due to the increased transmitter and receiver efficiencies the maximum crosstalk volume on long loops may be increased by as much as 10 db (T+R) for 500 series sets over 300 series common battery talking sets, but very little or none over local battery talking sets with HC5 receivers. In cases where long runs of small size cable have been placed with splicing lengths in the order of 3000 feet, or where non-staggered twist cable is near the subscriber, some of the crosstalk couplings may be high enough to be the source of crosstalk complaints when either 500-type or LBT-HC5 sets are used. In such cases, remedial measures such as intermediate random splices in long runs may be necessary to provide sufficient crosstalk margin. On short and medium length loops the crosstalk performance of 500 series sets equipped with equalizers compares favorably with that of 300 series sets. The crosstalk performance of 500 series sets not equipped

with equalizers may not be satisfactory under certain loop conditions. Further discussion of this subject may be found in the subdivisions of the section dealing with specific types of sets.

5.03 An improvement of about 10 db in the sidetone balance of the 500 series set on relatively long loops has offset the sidetone effect of the increased efficiencies of the

transmitter and receiver. However, as the loop length decreases, the control of sidetone becomes dependent upon equalizer action. As previously mentioned two methods of equalization are used in the 500 series sets. The actions of these two methods with relation to sidetone control differ and are therefore discussed in the subdivisions of the section which cover each type. In general, the 500 series sets compare favorably with the 300 series in sidetone balance for most loop and battery supply conditions.