

7376 LOOP START/GROUND START SIGNALING REPEATER

| CONTENTS | PAGE |
|--------------------------------|------|
| 1. GENERAL | 1 |
| 2. SPECIFICATIONS | 1 |
| 3. CIRCUIT DESCRIPTION | 2 |
| 4. INSPECTION | 3 |
| 5. MOUNTING | 3 |
| 6. INSTALLER CONNECTIONS | 4 |
| 7. OPTIONS | 4 |
| 8. TESTING | 6 |

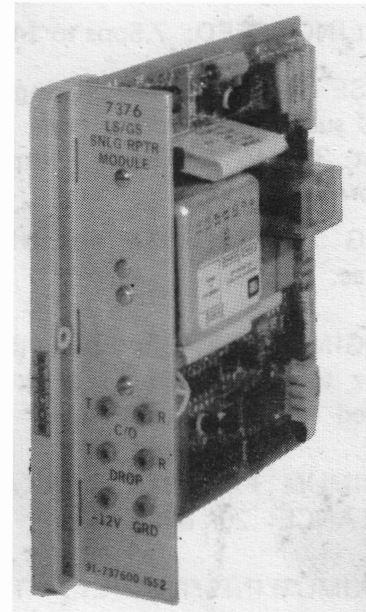

Figure 1. 7376 Loop Start/Ground Start Signaling Repeater

1. GENERAL

1.01 This Section provides circuit description, installation, and basic testing information for the Wescom 7376 Loop Start/Ground Start Signaling Repeater.

1.02 The 7376 Loop Start/Ground Start Signaling Repeater (Figure 1) is a plug-in, printed circuit module used to increase the effective signaling, supervisory, and dial pulsing range of an individual 2-wire line or PBX trunk. The 7376 operates in either the loop-start or ground-start mode, and is available with (when ordered as 7376-01) or without (when ordered as 7376-00) pulse correction.

1.03 Features provided by the 7376 are electronic ring detection, ring-trip, and line-and drop-current limiting (with a high-current protection circuit on the drop side). In addition, the module provides a control lead to disable an associated repeater during idle.

1.04 The 7376 is designed to mount in one position of a Wescom Type 400 Mounting Assembly. Type 400 Mounting Assemblies are available in capacities of one to 13 modules and allow for either KTU apparatus-case or relay-rack mounting.

1.05 The 7376 makes electrical connection to associated equipment by means of a 56-pin wire-wrap connector included as part of the mounting assembly.

2. SPECIFICATIONS

2.01 Specifications describing the electrical and physical characteristics of the 7376 are as follows:

- (a) **MAXIMUM LOOP SIGNALING LIMITS:**
3000 ohms, -48Vdc operation; 6000 ohms, -96Vdc operation.

Section 7376-101/3

- (b) MAXIMUM LOOP CURRENT (CO SIDE): 40mA.
- (c) MAXIMUM LOOP CURRENT (DROP SIDE): 45mA.
- (d) DIALING SPEED: 7.5pps to 14pps.
- (e) PULSE CORRECTION (Using optional 7389 subassembly, order code 7376-01): Input, 30% to 75% break; Output 58%±2% break at 10pps.
- (f) RING SENSITIVITY (LINE SIDE): 50Vac.
- (g) RINGING VOLTAGE: 85Vac to 130Vac, 16Hz to 67Hz (battery- or ground-connected ring generator).
- (h) MINIMUM FACILITY LEAKAGE RESISTANCE: 20k ohms.
- (i) MAXIMUM INPUT LEVEL: +10dBm.
- (j) FREQUENCY RESPONSE: 300Hz to 3400Hz±1dB.
- (k) INSERTION LOSS: 0.5dB (maximum).
- (l) PROTECTION CIRCUIT ENERGIZING CURRENT: Either HC relay winding, 87mA (approximately); Total, both windings, 44mA (approximately).
- (m) POWER REQUIREMENTS (Including battery feed to loop): 30mA (idle), 150mA (maximum) at -48Vdc, +48, -72, or -96Vdc at 90mA, maximum (Optional for Drop Loop Current Boost).
- (n) OPERATING ENVIRONMENT: Temperature, 32°F to 120°F; Humidity to 95% (no condensation).
- (o) WEIGHT: 2.5 lbs. (approximately).
- (p) DIMENSIONS: Height, 5-19/32 inches; Width, 1-½ inches; Depth, 6 inches.
- (q) MOUNTING: KTU apparatus-case or relay-rack.

3. CIRCUIT DESCRIPTION

3.01 The 7376 is capable of either loop-start or ground-start operation and can extend the signaling and supervisory range of a 2-wire line to a maximum of 6000 ohms (96V operation). Refer to the functional block diagram (Figure 4) while reading the following circuit description.

Central Office to Station Call (Loop Start)

3.02 On an outgoing call from the CO to the local station, the CO applies ringing voltage to the ring and ground to the tip of the line. This ringing voltage is detected by the ring detector. In conjunction with the drop side tip sensor being off and the ring trip circuit being inactive, the logic circuit will operate relay R. The contacts of relay R apply ringing generator to the drop ring (pin 49) and ringing generator ground to the drop tip (pin 41). When the local station goes off-hook in response to ringing, dc flows through the ring generator, the ring-trip circuit, the closed contacts of relay R, and the station to ring generator ground. The ring-trip circuit detects this current causing the logic circuit to operate, releasing relay R. This action disconnects ringing from the station. With relay R released, loop current now flows from loop sensor B through the high current (HC) protection circuit, the ring lead, the station set, the tip lead, and the HC circuit to loop sensor A. Since the Tip and Ring Sensors are on, and the CO tip sensor is locked on (by LS switch, S3), the logic circuit output is negative. This provides a negative input to the pulse corrector, which in turn operates relay A. Operation of relay A closes the loop to the CO, tripping ringing from the CO.

CO to PBX (Ground Start)

3.03 Operation in the ground start mode is essentially the same as described in paragraph 3.02 with the exception that the 7376 receives a ground signal on the tip lead from the CO. This ground is detected by the ground-start circuit which operates relay TG. The contacts of relay TG apply ground to the tip lead towards the

drop preparing the PBX for incoming ringing and blocking outgoing calls. The CO may now apply ringing to pins 33 and 51 as described in paragraph 3.02.

PBX to CO (Ground Start)

3.04 The PBX on the drop side initiates a call by placing ground on the ring lead (pin 49). This causes the ring sensor to turn on, allowing relay GS to operate. The contacts of relay GS apply ground to the ring side toward the CO. The CO acknowledges the ring-side ground request for service, and responds with dial-tone and tip ground. This tip ground turns on the ground start circuit which causes relay TG to operate. The contacts of relay TG connect the tip sensor to the tip side of the drop facility or PBX. The PBX, upon receipt of the tip ground, removes its ground from the ring side and then options the trunk for loop seizure. At this point, dial pulsing may begin.

Station to CO (Loop Start)

3.05 When the local station goes off-hook, loop current flows through the tip and ring leads and is detected by the tip- and ring-loop sensors. These sensors being turned on in conjunction with the tip ground sensor (locked by switch LS), operate relay A as previously described. When relay A operates, the loop toward the CO is closed through relay A's contacts, causing loop current from the CO to flow. As the station dials, the loop current on the drop side is pulsed, causing relay A to operate and release at the dial-pulse rate. The contacts of relay A pulse the CO battery. Pulse correction is accomplished by the optional 7389 unit (if provided).

HC Protection Circuit

3.06 The 7376 is provided with an HC protection circuit consisting of relay HC and associated circuitry. This circuit prevents excessive

current in the drop side of the unit by operation of relay HC if the drop current exceeds approximately 44mA. When relay HC operates, its contacts place the four resistance lamps in series with the tip and ring leads of the drop. The insertion of these lamps limits the drop current to approximately 40mA or less.

4. INSPECTION

4.01 Inspect the equipment thoroughly, as soon as possible after delivery. If the equipment has been damaged in transit, report the extent of damage to the transportation company immediately. If the equipment is to be stored, make an operational check to determine that the equipment is in proper working order as received from the factory. After an indication of satisfactory performance has been obtained, the equipment may be stored for future installation. If the module is to be installed at once, make an operational check after the installation is completed.

4.02 Wescom equipment is specifically identified by the model number, final-assembly number, and issue number silk screened on the front panel of the plug-in module. At the start of production, the final-assembly number is assigned an issue number of 1. After the start of production, this issue number is advanced each time a major engineering change occurs. Therefore, be sure to use the model number and final-assembly issue number when making inquiries about the equipment.

5. MOUNTING

5.01 The 7376 is designed to mount in one module position of a Type 400 Mounting Assembly. Type 400 Mounting Assemblies are available in capacities of 1 to 13 modules and

Section 7376-101/3

may be equipped and prewired for any combination of modules from the Wescom product line.

KTU Apparatus Case Mounting

5.02 Type 400-1 (one-module) through 400-5 (five-module) Mounting Assemblies may be installed in a 16C (equivalent to WECO 16C) KTU apparatus case.

Relay Rack Mounting

5.03 Type 400-1 through 400-9 Mounting Assemblies require the use of mounting bars, when mounted on either a 19- or 23-inch relay rack. Type 400-10 and 400-11 Mounting Assemblies are provided with mounting brackets for mounting directly across 19-inch relay racks. Type 400-12 and 400-13 Mounting Assemblies are also provided with mounting brackets for 23-inch relay-rack mounting. These mounting brackets are arranged to mount on relay racks drilled to accept either 1- $\frac{3}{4}$ or 2-inch mounting plates.

5.04 Because Type 400-1 through 400-9 Mounting Assemblies must be installed on mounting bars, 7 inches of vertical space (four mounting spaces) are required for relay-rack mounting. Type 400-10 through 400-13 Mounting Assemblies, however, are provided with mounting extensions located on the sides of the mounting assemblies and require only 6 inches of vertical rack space. Install the mounting assembly in a KTU apparatus case or on a relay rack (as described in paragraphs 5.02 and 5.03) with mounting hardware provided.

Universal Shelf Mounting

5.05 When a high degree of flexibility is required to provide for new circuit arrangements as well as circuit rearrangements, the 7376 may be mounted in a Wescom Universal Shelf. The Universal Shelf permits all intermodule wiring and installer connections to be made at the front of the mounting assembly and provides maximum accessibility to these connections when changes are required. The Type 400UA-11 and 400UB-11 Universal Shelves provide mounting positions for up to 11 modules and are designed for mounting in a 19-inch relay rack. Type 400UA-13 and 400UB-13 Universal Shelves pro-

vide mounting positions for up to 13 modules and are designed for mounting in a 23-inch relay rack.

5.06 The 7376 is directly interchangeable with the Wescom 7370 DLL repeater and the 7372-00/01 and 7373 Loop Extenders. Substitution of these modules requires no wiring changes.

6. INSTALLER CONNECTIONS

6.01 When the 7376 is installed in a Type 400 Mounting Assembly, it makes electrical connection to associated equipment through a 56-pin, wire-wrap card connector provided as part of the mounting assembly. Make all installer connections to this connector in accordance with Table 1.

6.02 Type 400UA-11 and 400UA-13 Universal Shelves provide terminal block locations above the mounting assembly, whereas Type 400UB-11 and 400UB-13 Universal Shelves provide terminal block locations below the mounting assembly. When the 7376 is installed in a universal shelf, make all installer connections to these terminal blocks in accordance with Table 1.

CAUTION

Do not make any connection with power applied to the equipment or modules installed in the mounting assembly.

7. OPTIONS

7.01 The 7376 is provided with internal strapping options (Figure 2) which permit the use of either the internal or external talk battery supply to the drop side. The 7376 is factory wired with straps X and Z installed. If an external source of talk battery and ground is to be used, remove straps X and Z and install straps W and Y.

NOTE

When installing straps, use insulated strap wire and not larger than a 30-W soldering iron.

7.02 The 7376 is provided with three switches located on the component side of the printed circuit board. Switches S1 and S2 permit selection of either a 600- or 900-ohm termination toward the CO or drop, respectively. Switch S3

Table 1. Installer Connections

| INSTRUCTION | SCHEMATIC DESIGNATION | 56-PIN CONNECTOR ASSIGNMENT |
|---|---|-----------------------------|
| Connect: | | To: |
| CO line or PBX line (tip) | TO CENTRAL OFFICE OR PBX LINE CKT (T) | 51 |
| CO line or PBX line (ring) | TO CENTRAL OFFICE OR PBX LINE CKT (R) | 33 |
| Station or PBX DROP (tip) | DROP TO STATION OR PBX TRUNK CIRCUIT (T) | 41 |
| Station or PBX DROP (ring) | DROP TO STATION OR PBX TRUNK CIRCUIT (R) | 49 |
| Repeater Enable lead | RPTR ENABLE | 29 |
| Ring Generator (+) | RING GEN | 45 or 46 |
| Ring Generator (return) | RING GEN RETURN | 11 or 12 |
| Ringing Machine Start Lead | MACHINE START | 37 |
| Talk Battery Supply (-) (if required)* | -48V, -72V, or -96V TALK BATT | 53 |
| Talk Battery Supply (+) (if required)* | +48V or +24V or GRD | 13 |
| -48V Battery Supply Ground | -48V GRD | 35 17 |

*In the loop-start mode, when the 7376 is used with ground-connected ring generator, an external source of +48Vdc or -48Vdc may be connected to pin 13. In ground-start mode, -48Vdc only is connected to pin 13.

permits selection of either the loop-start or ground-start mode of operation. Refer to Figure 3 for an illustration of the locations of these switches.

7.03 If pulse correction is desired, the 7376 may be ordered as 7376-01. In this configuration, the pulse corrector unit attaches to the 7376 printed circuit board without increasing the physical dimensions or altering the mounting. If not originally ordered as 7376-01, the 7376 may be arranged to accept the 7389 by removing the strap between terminals 1 and 3, and then inserting the 7389.

NOTE

If the 7376 is not provided with the pulse corrector, a strap should be placed between connector terminals 1 and 3. Verify that this jumper is in place.

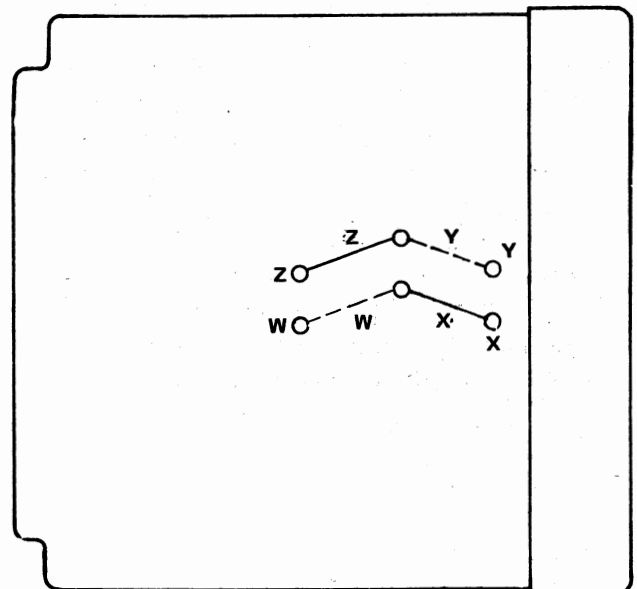

Figure 2. 7376 Strapping Option Location

Section 7376-101/3

7.04 The 7376 is provided with a screw option (CL) for use on CL loops that are greater than 1000 ohms. This screw option is located on the component side of the printed circuit board as shown in Figure 3. If the CO loop is greater than 1000 ohms, close screw option CL.

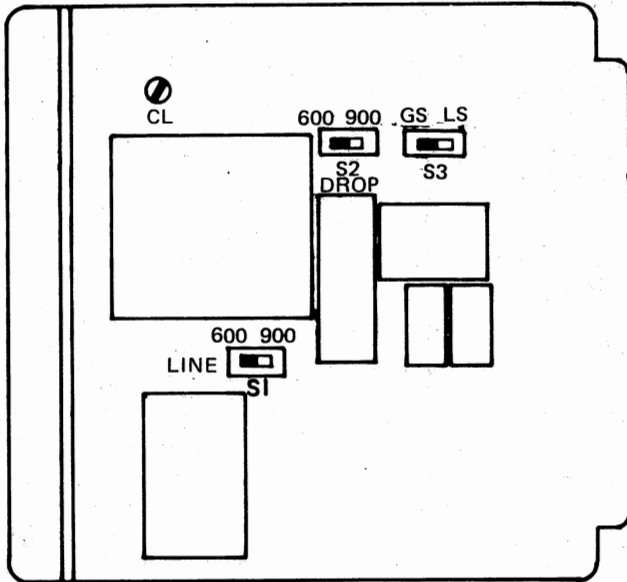

Figure 3. 7376 Switch Option Location

Inserting Modules

7.05 When all installer connections have been made and all options conditioned as required, insert the 7376 into the mounting assembly. An identification label designated 7376 is also provided on the front lower lip of the mounting assembly if the mounting assembly is factory wired.

CAUTION

The 7376 contains mercury-wetted relays. During shipment, excess mercury may collect on the contacts of these relays causing them to be

shorted. Consequently, the 7376 should be gently tapped on a hard surface while being held in an upright position before inserting the module in the mounting assembly.

CAUTION

Removal and installation of modules should be done with care. Do not force a module into place. If excessive resistance is encountered while installing a module, remove the module and check the card guides and connector for improper alignment and for the presence of foreign particles.

8. TESTING

8.01 If trouble is encountered with the operation of the 7376, verify that all installer connections have been properly made and that all options have been conditioned as required. With power removed, make certain that the module is making good connection with the mounting assembly card connector; remove and reinsert the module. If the trouble persists, perform the following test procedures (Tables 2 through 6) to determine whether the fault is internal or external to the module. If technical assistance is required, contact the Wescom Technical Services Department by calling (312) 971-2010 or TWX 910-692-4735.

Canadian Customers: (416) 742-0236 or TWX (610) 492-4367.

Test Equipment

- 8.02 Test equipment required to perform the test procedure is as follows:
- Multimeter: Simpson 260 (or equivalent), 20k ohm sensitivity.
 - Test Cords: as required.

Table 2. Voltage Regulator Test

| STEP | ACTION | VERIFICATION |
|------|--|-----------------------|
| 1 | Connect a multimeter set to the 50Vdc scale to the -12V and GRD test points. | Meter reads 12Vdc±1V. |
| 2 | Connect multimeter across pins 17 and 35 (circuit seized and idle). | Meter reads 48Vdc±4V. |

Table 3. Control Office Continuity Verification

| STEP | ACTION | VERIFICATION |
|------|--|--|
| 1 | If the module is arranged for loop start, connect a multimeter set to the 50Vdc scale to the CO T(+) and R (-) test points. | Meter should indicate CO battery potential. |
| 2 | If the module is arranged for ground start, connect the multimeter set to the 50Vdc scale from the CO R (-) lead to the GRD test points. | Meter should indicate CO battery potential. |
| 3 | Connect the multimeter to CO T and GRD test points. Place ground on the CO R lead. | Multimeter should read 50V indicating GS seizure and T to ground return from CO. |

Table 4. Drop Potential Verification

| STEP | ACTION | VERIFICATION |
|------|---|--|
| 1 | If the module is arranged for Loop Start, connect a multimeter set to the 250Vdc scale to the DROP T (+) and R (-) test points. | Meter should indicate 48, 72, or 96Vdc as supplied to the DROP station. If this condition is not met, check strapping options W, X, Y, and Z, for proper connection. |
| 2 | If the module is arranged for ground start, connect CO T lead to GRD. | Verify -48Vdc on DROP R lead and 0 potential on DROP T lead. |
| 3 | Set the multimeter to the 250Vac scale and request the CO or PBX to dial the associated station telephone number. | Meter should indicate ring voltage as supplied to the 7376 by the local ringing generator. If this condition is not met, verify that voltage from the CO or PBX at the line T&R test points is 50Vac or greater. |
| 4 | Place the associated station in the off-hook condition. | Meter reading should indicate removal of ac voltage verifying that ring trip has occurred. |
| 5 | Release all equipment. | |

Table 5. Ground Start Seizure Test

| STEP | ACTION | VERIFICATION |
|------|---|---|
| 1 | Place a short across the DROP T and R test points. | |
| 2 | Connect the negative lead of the multimeter (set on 50Vdc scale) to the DROP T lead test point. Connect the other multimeter lead to battery. | |
| 3 | Connect the R lead to ground. | Multimeter should indicate -48V potential on T lead. If -48V is not read, this is an indication of failure of TG relay. Change out and retest 7376. |
| 4 | Connect the multimeter across CO R and GRD test points. | Multimeter should indicate 0V potential, verifying operation of GS relay. If 0V is not read, change out and retest 7376. |

8.04 Field repairs involving the replacement of components within a module are not recommended. If a module is found to be defective, contact Wescom Inc., by telephone or TWX, for instructions regarding replacement or repair. If a replacement module is required, it will be shipped the fastest way, or as specified by the

customer. Upon receipt of a replacement module, return the defective module, using the shipping label provided, to Wescom, Inc., 8245 Lemont Road, Downers Grove, Illinois 60515.

Canadian Customers: Wescom Canada, Ltd., 87 Brydon Drive, Rexdale, Ontario, Canada.

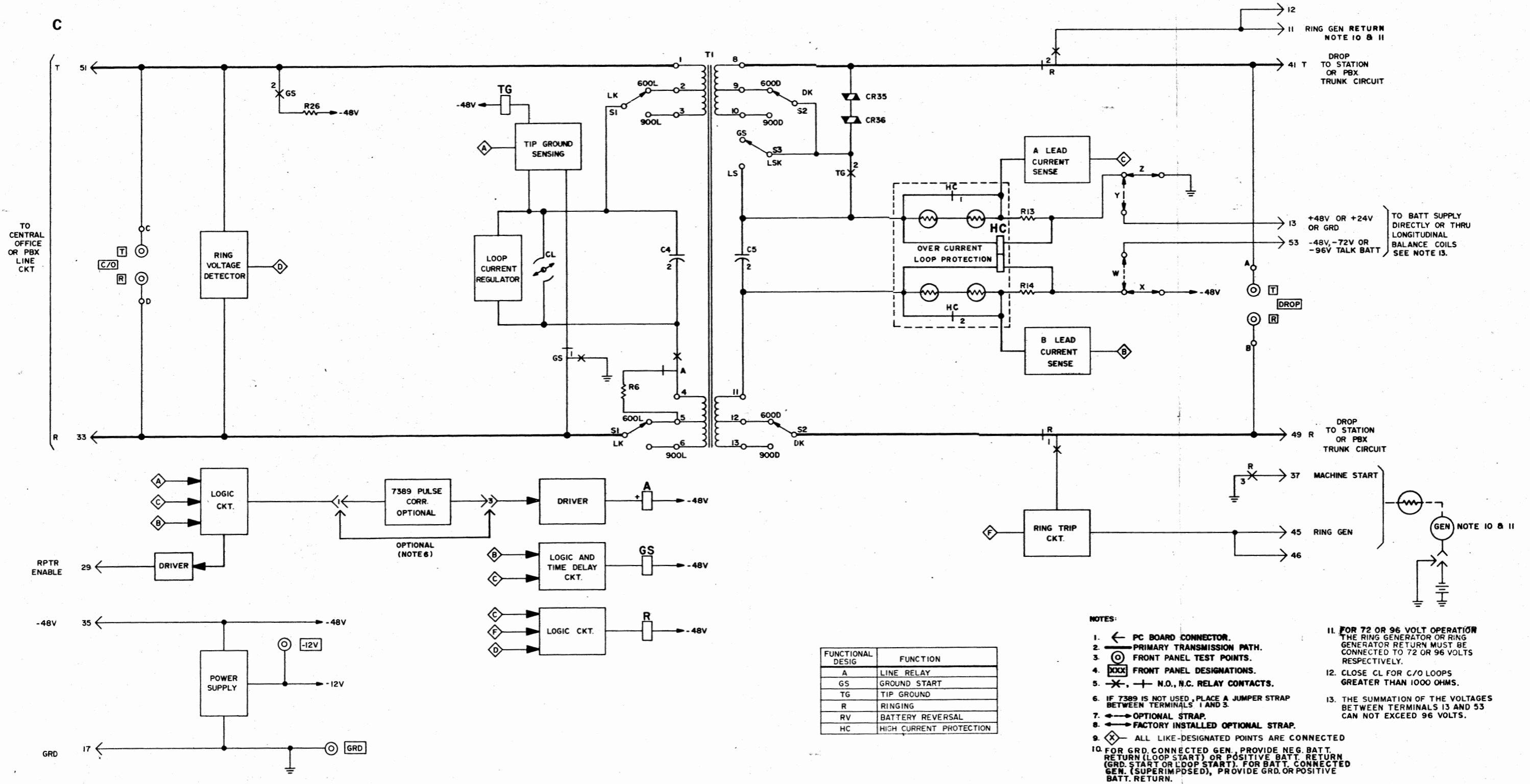

Figure 4. 7376 Functional Block Diagram (Issue 2)