

## 405 Combination Pickup Relay and Station Circuit

CONTENTS	PAGE
1. GENERAL . . . . .	1
2. APPLICATIONS . . . . .	1
3. CIRCUIT DESCRIPTION . . . . .	5
4. INSPECTION . . . . .	7
5. MOUNTING . . . . .	7
6. INSTALLER CONNECTIONS . . . . .	7
7. OPTIONS . . . . .	8
8. TESTING . . . . .	9
9. WARRANTY . . . . .	9
10. SPECIFICATIONS . . . . .	10

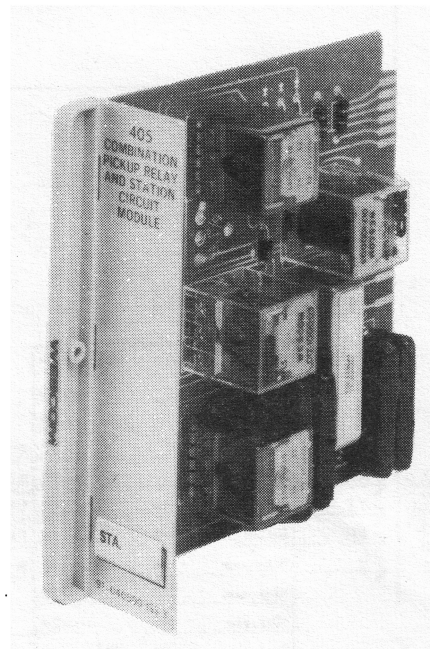

Figure 1. 405 Combination Pickup Relay and Station Circuit

### 1. GENERAL

1.01 This Practice provides circuit description, installation procedures, and basic testing information for the Wescom® 405 Combination Pickup Relay and Station Circuit (Figure 1). This Practice has been reprinted to include applications information and a general editorial update.

1.02 The 405 is a plug-in, printed circuit board module used for talk battery, dialing control, push-to-talk operation, and access to the 4-wire line from a 4-wire station set.

### 2. APPLICATIONS

2.01 The 405 provides a pickup relay circuit and a 4-wire station circuit. It is always used at the station end of a circuit in conjunction with a 4-wire private line telephone or a 2-wire/4-wire key telephone set similar to the Wescom 8640 Telephone Set or the Wescom 8642 Telephone Set, respectively. The 405 is normally used with a Wescom 401 4-Wire Line Amplifier and a Wescom 402 4-Wire Line Termination Circuit and any associated signaling equipment (VF, SS-1A, ringdown, etc.). Typical applications of the 405 are shown in Figures 2, 3, and 4.

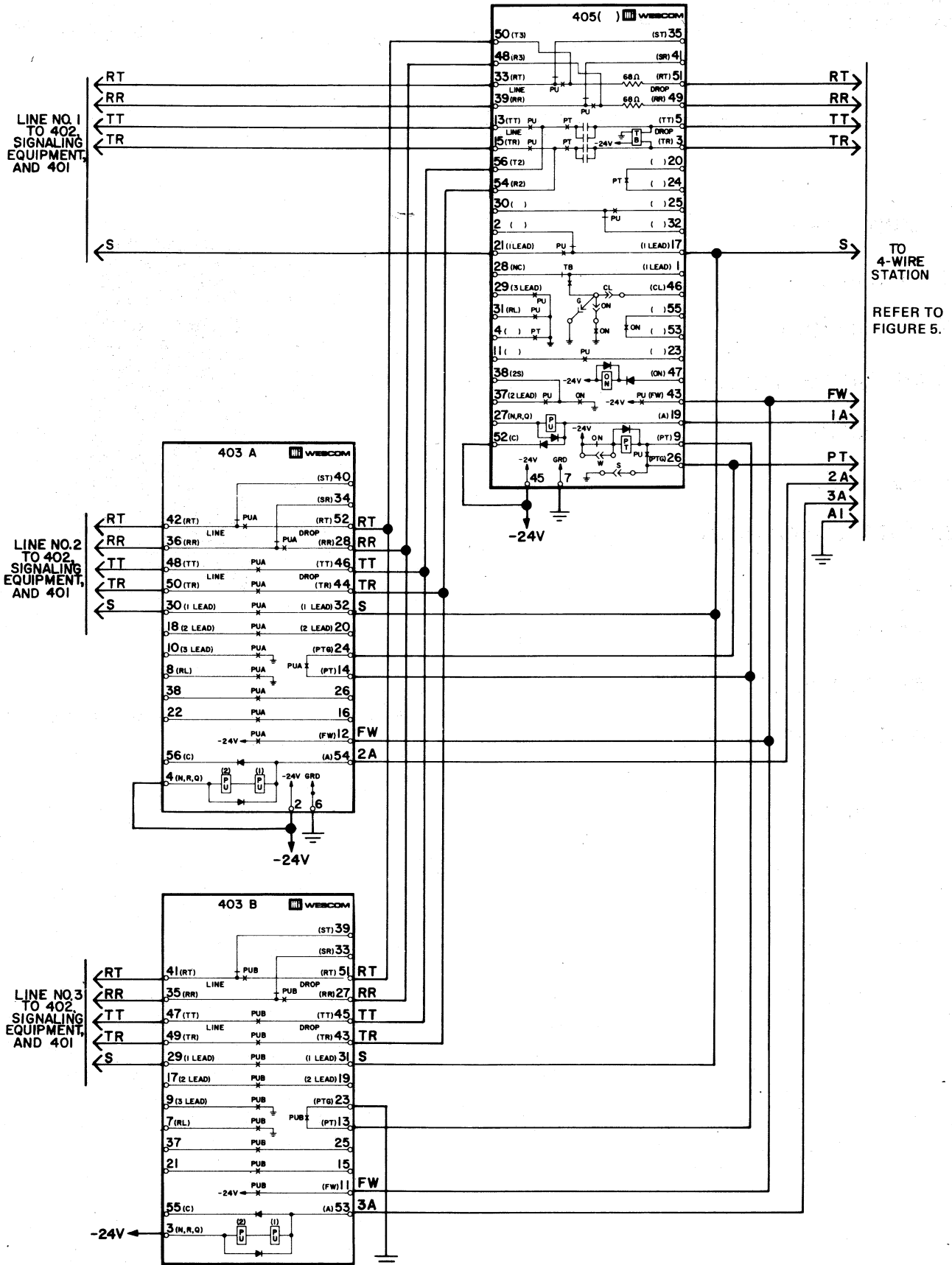

Figure 2. Station Access to Three Lines Using One 405 and One 403

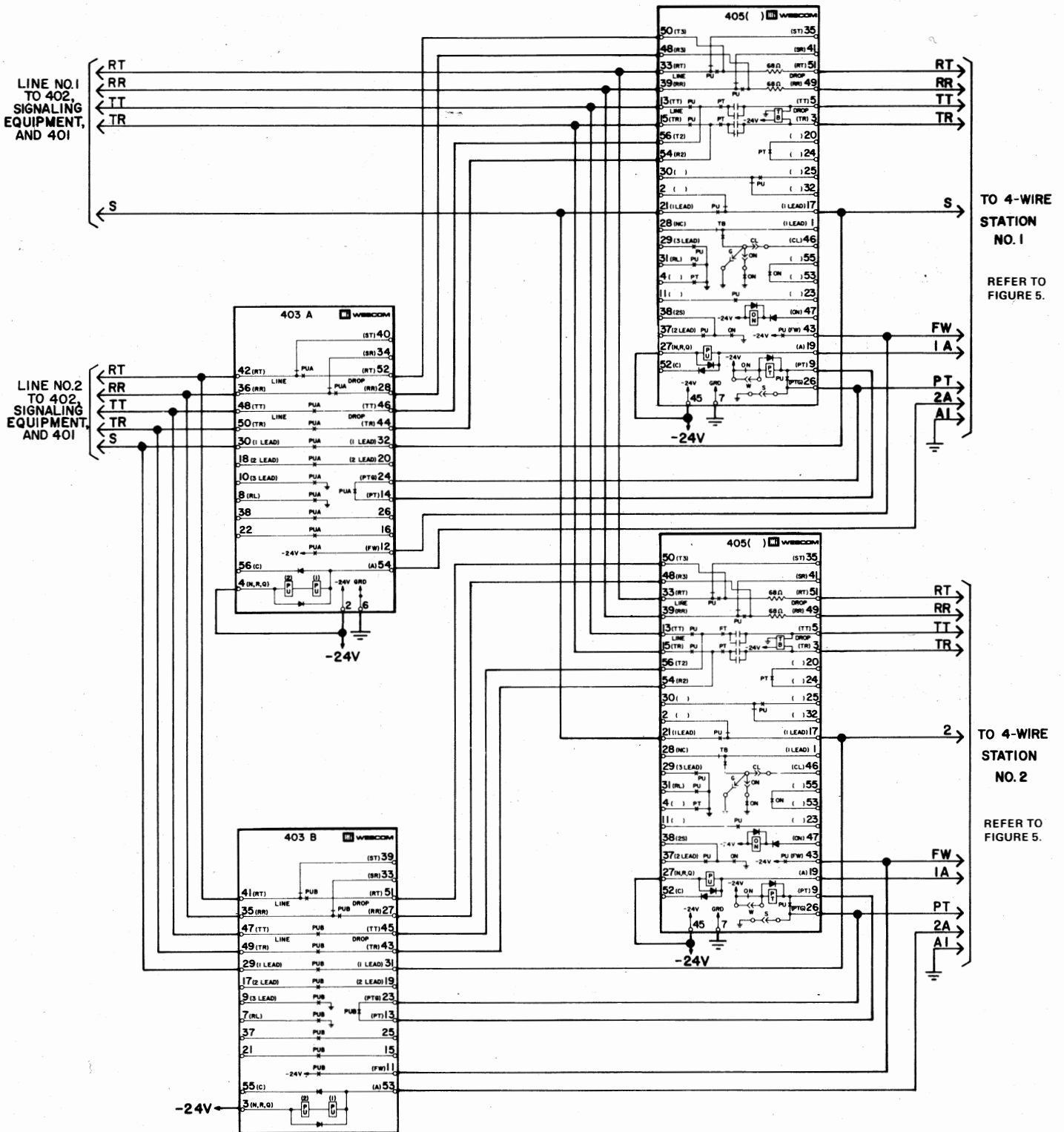
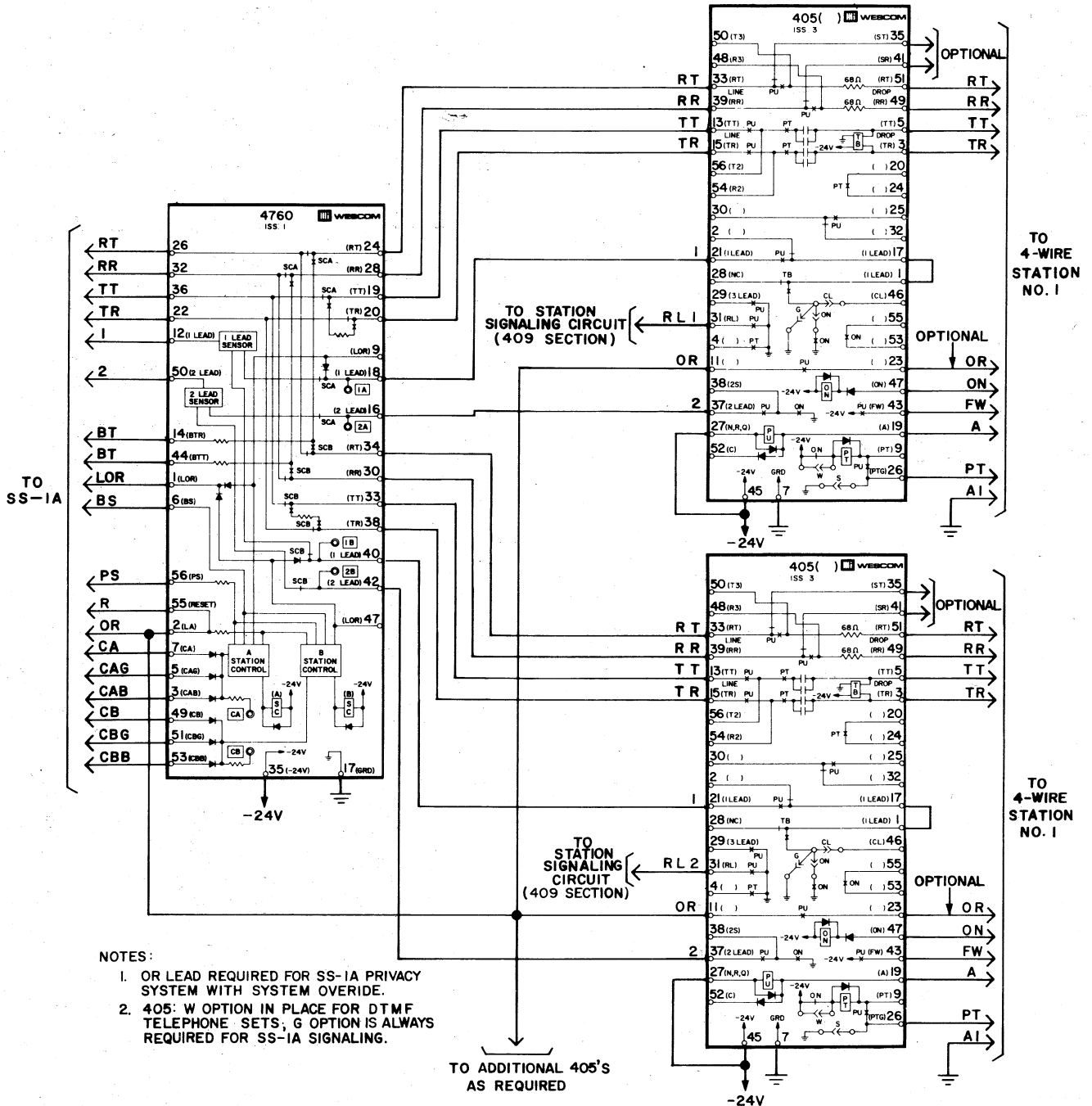

Figure 3. Two Station Access to Two Lines Using Two 405's and One 403



- NOTES:
1. OR LEAD REQUIRED FOR SS-1A PRIVACY SYSTEM WITH SYSTEM OVERRIDE.
  2. 405: W OPTION IN PLACE FOR DTMF TELEPHONE SETS; G OPTION IS ALWAYS REQUIRED FOR SS-1A SIGNALING.

Figure 4. Two Station Access to One SS-1A Line Using Two 405's and One 4760

2.02 In Figure 2, the 405 is shown connected to a subscriber station. This allows the set access to one 4-wire circuit. The addition of a Wescom 403 Dual Pickup Relay allows the set access to two additional circuits. Each of these three circuits, illustrated in Figure 2, is also terminated in a 402, signaling equipment, and the 401. (This equipment is not shown due to space limitations.) Each circuit would then be connected to a facility (wire line/metallic or carrier multiplex) for transmission to other locations.

2.03 In Figure 3, two sets are shown connected to two 405's and one 403. This allows each of the handsets access to two circuits. The transmission circuitry (402, signaling equipment, and 401) is again not shown.

2.04 In Figure 4, two handsets are connected to two 405's and then connected to a Wescom 4760 Dual Station Control. This configuration allows the two handsets access to one SS-1A circuit. The use of the 4760 provides individual station lock-out for privacy operation. One or more 403 Dual Pickup Relays may be employed in this application, using the techniques shown in Figures 2 and 3. One pickup relay is required per station control.

2.05 In the applications discussed above, the following criteria are met, and must always be met, when using the 405 in similar applications. There must be one station circuit per subscriber set (part of the 405) and one pickup relay per circuit per subscriber set (part of the 405 or two in the 403).

2.06 For further applications information, refer to the WesPAC Engineering Manual.

### 3. CIRCUIT DESCRIPTION

3.01 The 405 is a printed circuit board module used for talk battery, dialing control, push-to-talk operation, and access to the 4-wire line from a 4-wire station handset. Refer to Figure 7, the 405 Combination Pickup Relay and Station Circuit Schematic Diagram, during the

following circuit description. Figure 5, Typical 2-Wire/4-Wire Key Telephone Set, is provided for reference purposes only.

3.02 The 405 can be conveniently split into two circuits: a pickup relay circuit and a station circuit. The pickup relay circuit consists of the pickup relays (PU1 and PU2) and their associated circuitry. The station circuit consists of the push-to-talk relay (PT), the dial off-normal relay (ON), and the talk battery relay (TB) and their associated circuitry.

#### Pickup Relay Circuit

3.03 The PU relays operate under the control of an associated station set A lead. When the associated station goes off-hook, a ground is applied to the A lead, operating the PU relays. The operation of these relays causes the following to occur:

- (a) The transmission and signaling leads of the associated station circuit are connected to the circuit common equipment transmission and signaling leads terminating the 4-wire line,
- (b) A ground is provided on the RL lead for ring disable to the 409 Group Code Circuit (when used),
- (c) -24Vdc is connected over the FW lead to operate the FW relay in the station set (this functions to convert the set from the standard 2-wire mode to the 4-wire mode), and
- (d) Auxiliary PU relay contacts are operated to provide various functions depending on application.

3.04 When push-to-talk service is not required, the PU relays, in conjunction with strapping option S, connects ground to operate the PT relay in the station circuit. This permits a set to be used with or without push-to-talk operation depending on the user requirements and Special Service Order (SSO) specifications.

3.05 When VF (loudspeaker) signaling is used, the operated PU relays disconnect the associated speaker from the receive side of the

Section 405-101/3

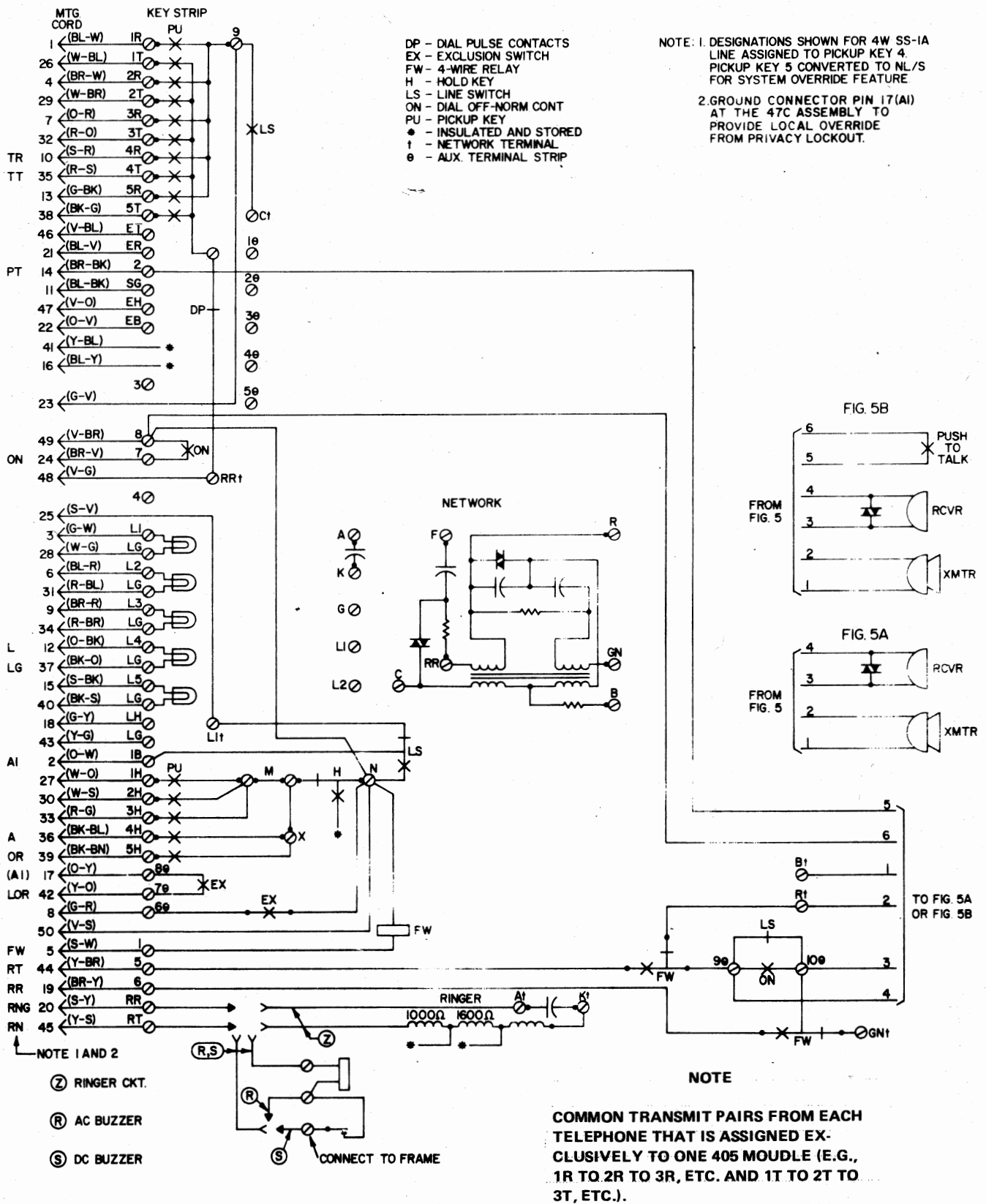

Figure 5. Typical 2-Wire/4-Wire Key Telephone Set

line to mute the speaker when the station handset is off-hook.

### Station Circuit

3.06 The station circuit provides talk battery to the handset, dialing control, and push-to-talk operation. The TB relay supplies talk battery and ground to the local station set through the transmit drop. The talk battery is blocked from the transmit line by capacitors C1, C2, C3, and C4. Relay TB is energized by loop current when the station is off-hook and is released by the break portions of a dial pulse train. During dialing with SS-1A applications, the TB relay converts loop dialing from the set to 1-lead signals to the SS-1A selective signaling equipment.

3.07 The PT relay operates in response to a ground signal supplied on the PT lead by the station set. When relay PT is operated, the transmit path is terminated on the pickup relay contacts, and since the relay is operated, the transmit drop is cut-through to the transmit line.

3.08 Relay ON is energized when the station set dial is moved off-normal. When relay ON is operated, it provides a 2-lead ground corresponding to dial-off-normal. The operation of relay ON optionally cuts through the 1-lead output, when strapping option NO is utilized. Strapping option G is normally employed to provide a 1-lead ground during the station off-hook interval.

## 4. INSPECTION

4.01 Inspect the equipment thoroughly as soon as possible after delivery. If the equipment has been damaged in transit, immediately report the extent of damage to the transportation company.

4.02 Wescom equipment is identified by a model and issue number imprinted on the front panel. Each time a major engineering design change is made on the equipment, the issue number is advanced by one number on any following models that are manufactured. Therefore, be sure to include the issue number along with the model

number when making inquiries about the equipment.

## 5. MOUNTING

5.01 The 405 is a plug-in module designed to mount in one module mounting position of a Wescom 400 Mounting Assembly. The 400 Mounting Assemblies are available in various module capacities and allow for Key Telephone Unit (KTU) apparatus-case or relay-rack mounting. Refer to Sections 400-103 and 400-U-101/3 for further information on these mounting assemblies.

## 6. INSTALLER CONNECTIONS

6.01 When the 405 is installed in its module mounting position in a 400 Mounting Assembly, it makes electrical connection to the associated equipment through a 56-pin, wire-wrapped card connector provided as part of the mounting assembly. One card connector is located on the backplane of each module mounting position. Make all installer connections to this card connector in accordance with Table 1.

### CAUTION

Do not make any connections with power applied to the equipment or modules installed in the mounting assembly.

Table 1. 405 Installer Connections

CONNECT *	TO 56-PIN CONNECTOR
Transmit drop tip lead (T)	5
Transmit drop ring lead (R)	3
Receive drop tip lead (RT)	51
Receive drop ring lead (RR)	49
Transmit line tip lead (T1)	13
Transmit line ring lead (R1)	15
Receive line tip lead (T)	33
Receive line ring lead (R)	39
A lead	19
NOTES	
*All parenthetical lettering is a reference to schematic designations (refer to Figure 7).	
†Local override.	
**System override.	

Table 1. 405 Installer Connections (Cont)

CONNECT*	TO 56-PIN CONNECTOR
Privacy intrusion key (AG)†	30
Privacy intrusion key (AGS)†	25
Privacy override key (M, Q)**	23
Privacy override key (T, H)**	11
Push-to-talk lead (PT)	9
Push-to-talk lead (PTG)	26
PU relay energizing voltage (N, R, OR Q OPTION)	27
FW lead	43
Dial-off-normal lead (ON)	47
1 lead	1
2 lead	37
3 lead	29
Speaker tip lead (ST)	35
Speaker ring lead (SR)	41
RL lead	31
R or ZC lead	21
I or S lead	17
NC lead	28
CL lead	46
J lead	4
P3 lead	55
P4 lead	53
C lead	52
S2 lead	38
T2 lead	56
R2 lead	54
T3 lead	50
R3 lead	48
Normally closed relay contact (PU2-4)	2
Normally open relay contact (PT-4)	20
Normally open relay contact (PT-4)	24
Normally closed relay contact (PU2-1)	32
-24V	45
Ground	7

NOTES

\*All parenthetical lettering is a reference to schematic designations (refer to Figure 7).

†Local override.

\*\*System override.

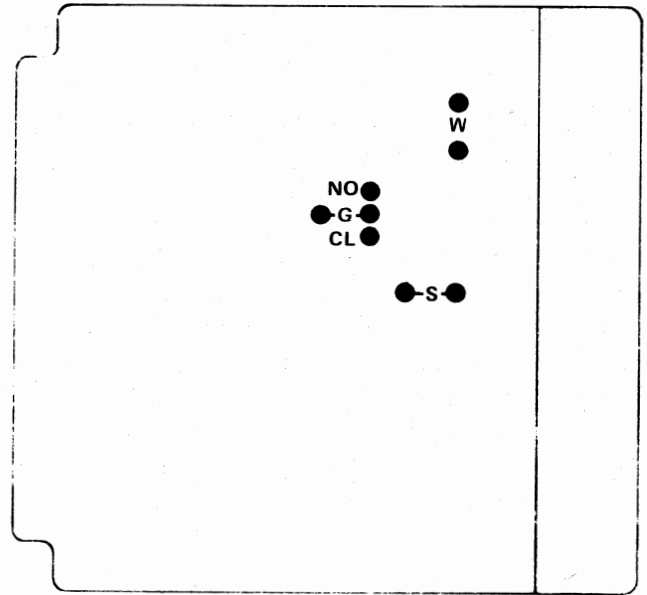

Figure 6. 405 Strapping Option Locations

**NOTE**

Although the strapping locations are silkscreened on the component side of the printed circuit board, all strapping is to be done on the foil side of the board.

**CAUTION**

When installing straps, use insulated strap wire and not larger than a 30W soldering iron.

**7. OPTIONS**

7.01 The 405 is equipped with strapping posts for conditioning the various circuit options. All strapping posts are located on the foil side of the module. Refer to the following paragraphs for option conditioning information and to Figure 6 for the locations of the strapping posts.

7.02 Strapping option S is factory-installed. It is used only when push-to-talk operation is not required. When option S is in place, the PT relay is slaved to the PU relays. If push-to-talk operation is required, remove strapping option S.

7.03 Strapping option G is factory-installed. When option G is in place, a ground is provided on the 1 lead, under the control of the TB relay, when the station set is off-hook. The 1 lead will be momentarily open during dial pulses. This option is normally required for all 4-wire private line applications. If this feature is not required, remove strapping option G.

7.04 The ON option, when customer-installed, allows dialing on an SS-1A circuit by a station when another station at the same location and served by the same SS-1A terminal is off-hook. The ON strapping option may be used in the absence of a station control circuit (e.g., Wescom 4760 Dual Station Control) and the station control circuit's associated lock-out features are not required.

7.05 When a Dual Tone Multi-Frequency (DTMF) telephone is used and the station is in a lock-out during dial or privacy application, where an ON lead must be provided, the W strapping option is required to complete the transmission path during DTMF dialing.

7.06 The CL strapping option, when customer-installed, provides external control of the 1-lead state when the TB relay is energized through the use of the CL lead.

7.07 When all installer connections and option conditioning have been completed as required, the 405 may be mounted in its module mounting position in the Wescom 400 Mounting Assembly.

#### CAUTION

Removal and installation of modules should be done with care. Do not force a module into place. If excessive resistance is encountered while installing a module, remove the module and check the card guides and connector to verify proper alignment and the absence of foreign material.

## 8. TESTING

8.01 If trouble is encountered with the operation of the 405, verify that all installer connections have been completed as required in accordance with Table 1 and that all options have been conditioned as required in accordance with part 7. Verify that the module is making good connection with the mounting assembly card connector; remove and reinsert the module. If

technical assistance is required, contact the Wescom Technical Services Department by calling:

(312) 971-2010,  
TWX 910-695-4735, or  
DATAPHONE (312) 971-1698

Canadian Customers:

(416) 453-2222 or  
TWX 610-492-2697

## 9. WARRANTY

9.01 **STANDARD WARRANTY:** Wescom products are warranted to be free from defects in material, workmanship, and design given proper installation and regular maintenance. Wescom's obligations under this warranty are limited to correction and replacement at Wescom's production facility of any defective items received by Wescom, transportation prepaid, for a period of five years from the date of original shipment. Warranty and remedies on products not manufactured by Wescom are in accordance with the warranty of the respective manufacturer. **WESCOM MAKES NO OTHER WARRANTY OF ANY KIND WHATSOEVER, EXPRESSED OR IMPLIED; AND ALL IMPLIED WARRANTY OF FITNESS FOR A PARTICULAR PURPOSE WHICH EXCEEDS THE AFORESAID OBLIGATIONS IS HEREBY DISCLAIMED BY WESCOM.**

9.02 Field repairs involving the replacement of components within a unit are not recommended. If an item is found to be defective, contact Wescom, Inc., by telephone or TWX, for instructions regarding replacement or repair.

9.03 If a replacement unit is required, it will be shipped in the fastest manner consistent with the urgency of the situation. Upon receipt of a replacement unit, return the defective unit in the carton in which the replacement was shipped, using the shipping label provided, to:

Wescom, Inc.  
8245 Lemont Road  
Downers Grove, Illinois 60515

## Section 405-101/3

### Canadian Customers:

Wescom Canada, Ltd.  
287 Glidden Road  
Brampton, Ontario L6W1H9  
Canada

### Repair or Exchange Services

9.04 In addition to the standard Wescom Warranty Service, Wescom offers a repair or exchange service for those items out of warranty. Under this arrangement, faulty units may be shipped to Wescom for either complete repair and quality testing or exchanged for a replacement unit. To obtain details of this service and a schedule of prices, contact your local Wescom Sales Representative.

## 10. SPECIFICATIONS

10.01 The electrical and physical characteristics of the 405 Combination Pickup Relay and Station Circuit are as follows:

- (a) STATION DROP LIMIT: 200 ohms.
- (b) POWER REQUIREMENTS: Filtered battery required, -21 to -30Vdc; -24Vdc nominal at 145mA maximum.
- (c) OPERATING ENVIRONMENT: Temperature, 32° to 120°F (0° to 50°C); humidity to 95% (no condensation).
- (d) MOUNTING: One module mounting position in a Wescom 400 Mounting Assembly.
- (e) WEIGHT: 0.69 lbs (0.31kg).
- (f) DIMENSIONS: Height, 5.6 inches (14.2cm); width, 1.5 inches (3.8cm); depth, 6 inches (15.2cm).

D

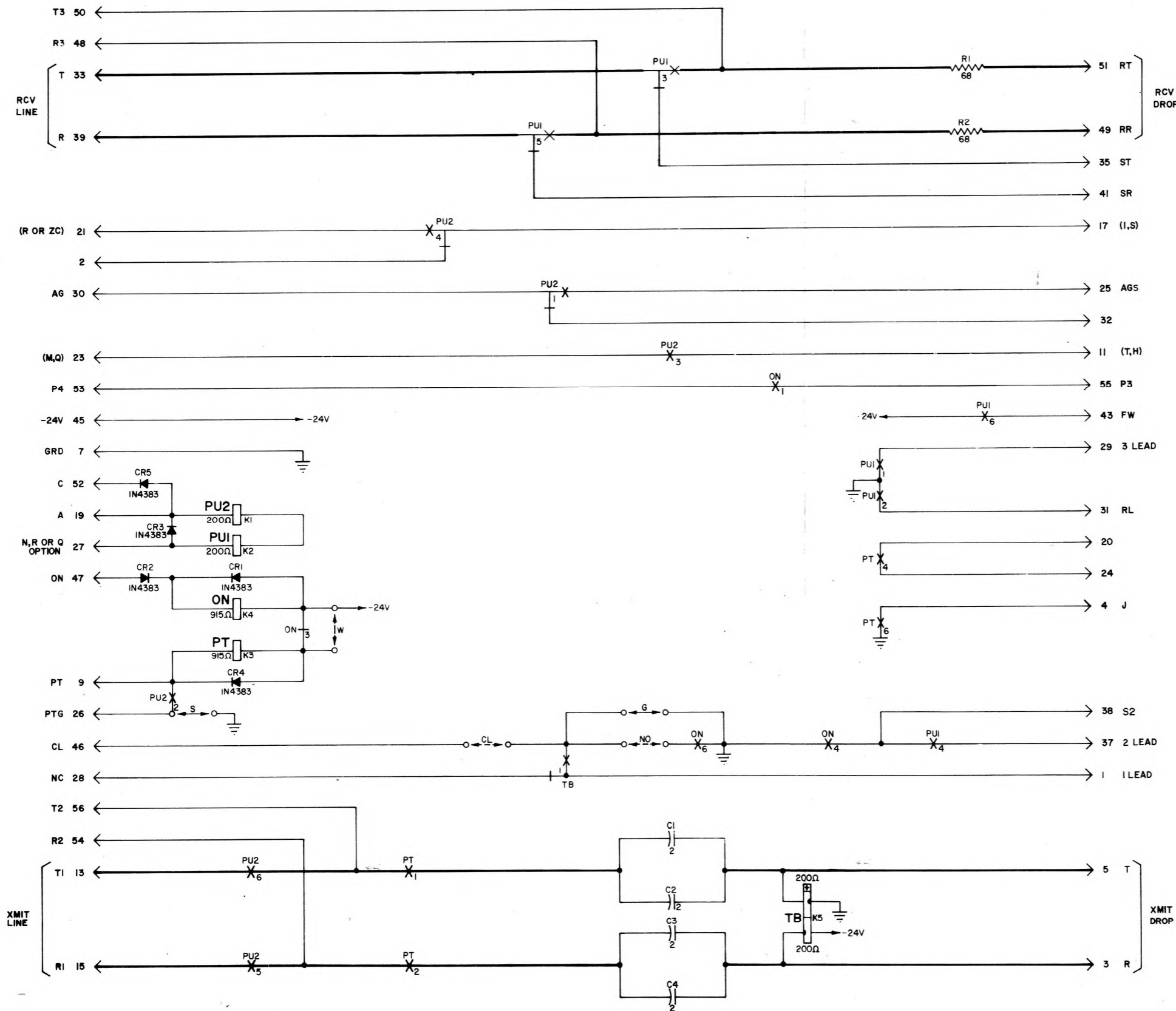

- NOTES:
- UNLESS OTHERWISE SPECIFIED: RESISTORS ARE IN OHMS, ±5%, 1/2WATT. CAPACITORS ARE IN MICROFARADS.
  - ← PC BOARD CONNECTOR.
  - PRIMARY TRANSMISSION PATH.
  - ↔ OPTIONAL STRAP.
  - ↔ FACTORY INSTALLED OPTIONAL STRAP.
  - X, +, - N.O. N.C. RELAY CONTACTS.
  - WHEN PUSH TO TALK IS REQUIRED, REMOVE OPTION (S).
  - WHEN THE I LEAD IS TO BE UNDER CONTROL OF THE K4 & K5 RELAY, REMOVE (G) AND (CL) OPTIONS AND ADD (NO) OPTION.
  - WHEN THE I LEAD IS TO BE UNDER EXTERNAL CONTROL, REMOVE (G) AND (NO) OPTIONS AND ADD (CL) OPTION.
  - STRAP (W) OPTION FOR SPECIAL USE OF "PT" RELAY NOT UNDER CONTROL OF "ON" RELAY.

RELAY REF. DESIG.	FUNCTIONAL DESIG.	FUNCTION
K1	PU1	PICK-UP (1)
K2	PU2	PICK-UP (2)
K3	PT	PUSH TO TALK
K4	ON	OFF NORMAL
K5	TB	TALK BATTERY

THIS PRINT IS THE PROPERTY OF WESCOM, INC. AND SHALL NOT BE REPRODUCED, COPIED OR USED IN ANY MANNER DETRIMENTAL TO THEIR INTERESTS.

Figure 7. 405 Combination Pickup Relay and Station Circuit Schematic Diagram (Issue 3)