

402 4-Wire Line Termination Module and 4020 Loopback Subassembly

CONTENTS	PAGE
1. GENERAL	1
2. APPLICATIONS	2
3. CIRCUIT DESCRIPTION	2
4. INSPECTION	4
5. MOUNTING	5
6. INSTALLER CONNECTIONS	5
7. OPTIONS	5
8. ALIGNMENT	6
9. TESTING	6
10. WARRANTY	6
11. SPECIFICATIONS	7

1. GENERAL

1.01 This Practice provides circuit description, installation procedures, alignment, and basic testing information for the Wescom® 402 Four-Wire Line Termination Module and the 4020 Loopback Subassembly (Figure 1). It is being reprinted to include Addendum A.

1.02 The 402 module interfaces a four-wire private line circuit with a group of up to 20 four-wire telephones connected in a conference configuration. It transforms the 600-ohm line impedance to a relatively low drop impedance to minimize the contrast in speech levels caused by changing the number of telephones involved in the

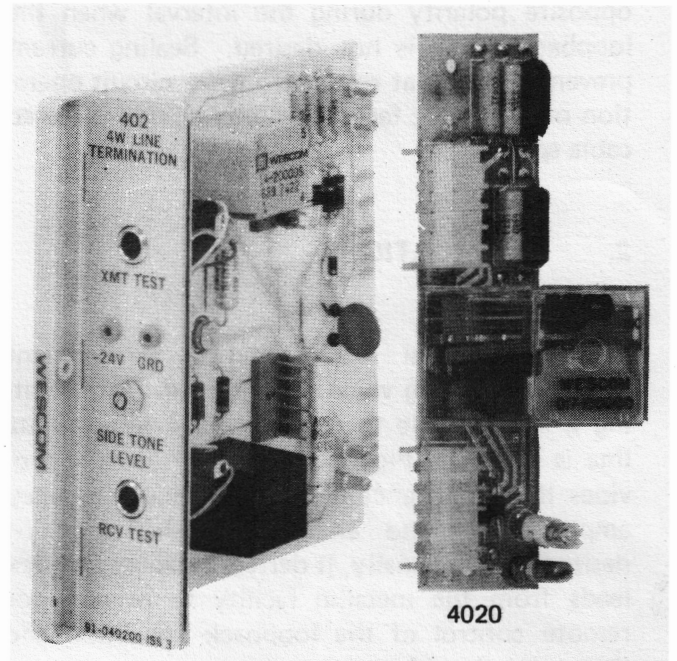

Figure 1. 402 4-Wire Line Termination Module and 4020 Loopback Subassembly

conference call. Additionally, the 402 provides sidetone to all telephones connected to the station (drop) side of the module. Sidetone allows the voice of the telephone user to be heard through the receiver of the same telephone as though using a standard 2-wire telephone. When more than one telephone is provided at the near location, it allows the user of each near end telephone to communicate with the users of the other near end telephones as well as with the user of the far end telephone.

1.03 The 402 is a plug-in, printed circuit module that mounts in one position of a Wescom Type 400 Mounting Assembly. Type 400 Mounting Assemblies provide for mounting the 402 with associated equipment in a Key Telephone Unit (KTU) apparatus case or on a relay rack.

1.04 The 4020 is an optional plug-in sub-assembly that mounts directly on the 402 module and equips it for equal transmission level loopback towards the line. Loopback is dc operated by a control current that may be transmitted via simplex leads derived from a metallic facility. Loopback control is polarity sensitive, permitting the application of sealing current of opposite polarity during the interval when the loopback mode is not desired. Sealing current prevents noise that results from dry circuit operation of a metallic facility employing non-soldered cable splices.

2. APPLICATIONS

2.01 A typical 4-wire station arrangement employing voice signaling and incorporating a 402 module to terminate a 4-wire private line is shown in Figure 2. The 401 module provides line impedance matching, voice frequency amplification, and amplitude equalization (if desired). Additionally, it derives a pair of simplex leads from the metallic facility to provide for remote control of the loopback condition and the application of sealing current.

2.02 The 402 is shown equipped with the optional 4020 subassembly which provides loopback operation toward the Serving Test Center (STC), Serving Central Office (SCO), and the distant terminal. It also provides a path for sealing current between the near-end transmit and receive paths. The 402 provides impedance step-down towards the station equipment and it adds sidetone to the receive path.

2.03 The 405 module provides a pickup relay for connecting the telephone into the circuit and for muting the loudspeaker while the telephone is off-hook. Additionally, the 405 provides for the dc isolation of the telephone transmit path and for the application of telephone talk battery current.

3. CIRCUIT DESCRIPTION

3.01 Refer to the schematic diagram of the 402 and 4020 shown in Figure 4 while reading the following description.

3.02 Voice energy, received from the distant terminal, via the facility is adjusted to a +7dBm transmission level by a line amplifier before entering the 402 module. Voice energy on the receive tip and ring leads enters the 402 on terminals 7 (tip) and 5 (ring) of the associated module connector and (assuming options C and D are closed) is coupled through transformer T2 and the RCV TEST jack to connector terminals 1 (tip) and 3 (ring). Terminals 1 and 3 conduct received voice energy to the station equipment connected on the drop side of the 402. This station equipment may be a single telephone connected through a 405 station circuit module. It may also be comprised of a group of up to 20 telephones each of which must be connected through a separate 405 module (one 405 per telephone) to the common receive and transmit paths on the drop side of the 402.

3.03 Transformer T2 has a step-down turns ratio to provide a low output impedance, permitting the parallel connection of up to 20 telephones. In so doing, T2 reduces the amplitude of the voice energy entering the 402 at a +7dB Transmission Level Point (TLP) to a -16dB transmission level for interfacing with the telephone.

3.04 Voice energy derived from the transmitter of the station equipment enters the 402 on connector terminals 55 (tip) and 53 (ring) and is coupled through the XMT TEST jack, transformer T1, a 9dB pad, and options A and B (closed) to connector terminals 51 (tip) and 49 (ring). Terminals 51 and 49 conduct voice energy to the line amplifier module which provides for amplitude adjustment to the transmission level required for interfacing with the transmit path of the 4-wire facility (typically 0dBm).

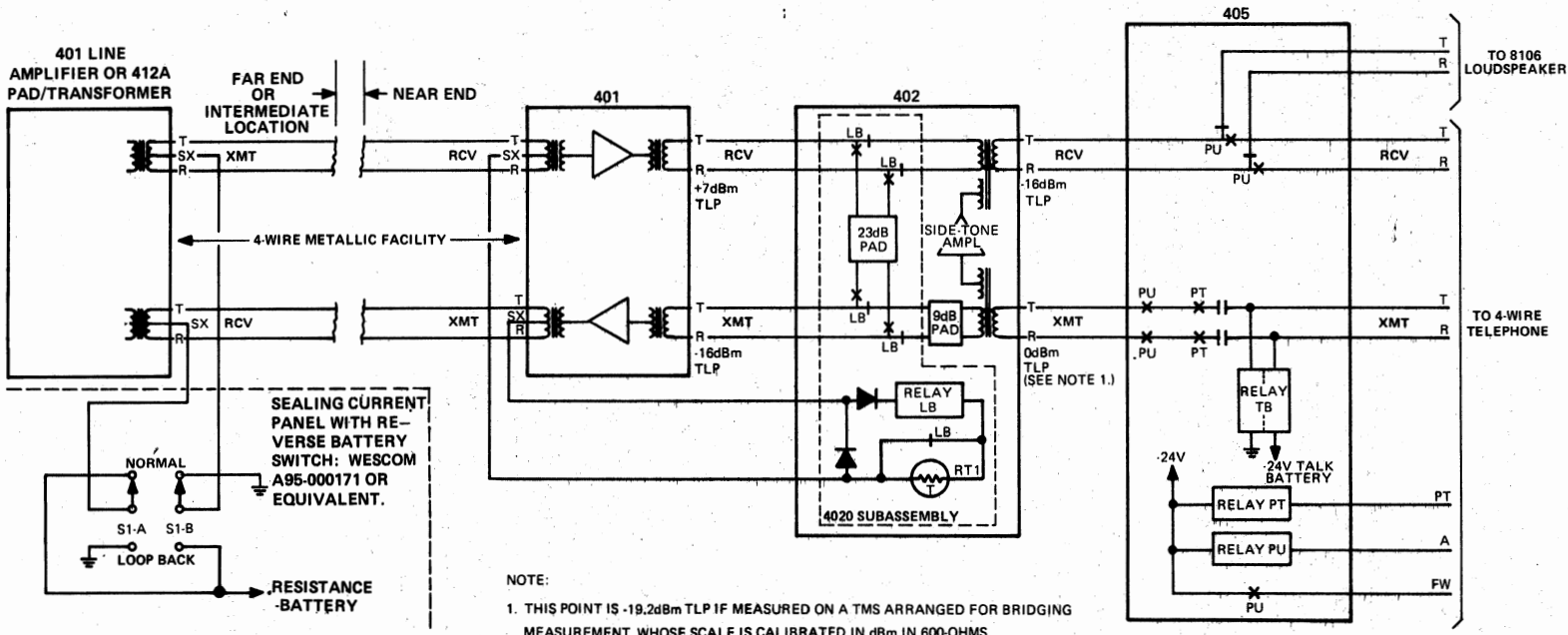

Figure 2. Typical Voice Signaling Application of the 402 Module

Section 402/4020-101/3

3.05 Transformer T1 has a step-up turns ratio (proceeding toward the line) to provide a low input impedance permitting the parallel connection of up to 20 telephones. The 9dB pad, following T1 in the transmit path, provides sufficient loss to place the transmit line terminals (51 and 49) of the 402 at a -16dB TLP.

3.06 A small amount of the voice energy in the transmit path is coupled through a third winding on T1 and then passed through the SIDE TONE LEVEL control and amplifier U1. It is then coupled into the receive path (through a third winding on T2) where it appears as sidetone energy.

Loopback/Sealing Current Arrangement

3.07 The 402, arranged for loopback operation, is provided with the optional 4020 Loopback Subassembly. In this arrangement, screw-type option switches A, B, C and D on the 402 pc board are open and the transmit and receive voice paths to the 4-wire line are completed through normally closed transfer contacts on relay LB (released) in the 4020. Relay LB is operated by applying a dc voltage to terminals 35 and 31 of the 402 (terminal 35 positive with respect to terminal 31). In system operation (as shown in Figure 2), operating current for relay LB (and sealing current) is applied to the simplex leads of the line amplifier at the distant end. Simplex leads derived by the line amplifier at the near end of the metallic facility conduct this current to the 402 module entering on terminals 31 and 35. Terminal 31 connects to the simplex lead derived from the receive path (far end transmit path) and terminal 35 connects to the simplex lead derived from the transmit path (far end receive path).

3.08 In the normal (non-loopback) condition, sealing current may be applied to the line. For this arrangement, option SC in the 4020 is closed and sealing current (normally 20mA) is applied at the distant end such that terminal 31 on the 402 is positive with respect to terminal 35. Current applied in this direction reverse biases the diode in series with the coil of relay LB, preventing the operation of this relay. Simultaneously, this current is bypassed around the coil of relay

LB by a second diode that is forward biased by current flow in this direction. Thus the path for sealing current is maintained while the operation of relay LB is prevented by these diodes.

3.09 The 402 is arranged for the loopback condition by reversing the polarity of the current applied to the simplex leads at the distant end of the metallic facility such that terminal 31 on the 402 is negative with respect to terminal 35. Current applied in this direction reverse biases the diode that bypasses the coil of relay LB while it forward biases the diode in series with the coil of relay LB. Thus relay LB operates, opening the transmit and receive paths toward the station equipment. Simultaneously, it interconnects the receive and transmit paths of the 4-wire line through a 23dB pad placed between TLPs of +7dB (receive) and -16dB (transmit).

3.10 While relay LB is operated, a set of normally closed contacts are held open inserting a resistance lamp in series with the coil of this relay to reduce the amount of holding current drain and to compensate for variation in simplex lead resistance. Additionally, a set of normally open auxiliary contacts on relay LB provides a closure between terminals 29 and 33 on the 402 during loopback that may be used to control the illumination of a loopback indicator.

3.11 The 402 is provided with a power supply regulator to supply stable, filtered outputs of -24Vdc and -12Vdc for powering the sidetone amplifier U1.

4. INSPECTION

4.01 Inspect the equipment thoroughly as soon as possible after delivery. If the equipment has been damaged in transit, immediately report the extent of damage to the transportation company.

4.02 Wescom equipment is identified by a model and issue number imprinted on the front panel. Each time a major engineering design change is made on the equipment, the issue num-

ber is advanced by one number on any following models that are manufactured. Therefore, be sure to include the issue number along with the model number when making inquiries about the equipment.

5. MOUNTING

5.01 The 402 is constructed as a plug-in module for mounting in one position of a Wescom Type 400 Mounting Assembly. Refer to Section 400-103 for information on appropriate mounting assemblies.

6. INSTALLER CONNECTIONS

6.01 The 402 module makes electrical connection to the associated equipment through a 56-terminal, wire-wrapped card-edge connector provided as part of the Type 400 Mounting Assembly. Make all installer connections to this connector in accordance with Table 1.

Table 1. Installer Connections for 402 Module

LEAD DESIGNATION	MODULE CONNECTOR TERMINAL ASSIGNMENT
XMT LINE (tip) TT1	51
XMT LINE (ring) TR1	49
RCV LINE (tip) RT1	7
RCV LINE (ring) RR1	5
XMT DROP (tip) TT	53
XMT DROP (ring) TR	55
RCV DROP (tip) RT	3
RCV DROP (ring) RR	1
SXT (transmit simplex lead)	35
SXR (receive simplex lead)	31
Loopback indicator closure	29
Loopback indicator closure (return)	33
-24V BATTERY supply	47
GRD (power return)	43
Internal jumper	13 to 15
Internal jumper	17 to 19
Internal jumper	21 to 23
Internal jumper	25 to 27

7. OPTIONS

Loopback

7.01 The 402 may be arranged for dc operated loopback toward the facility by the addition of the 4020 Loopback Subassembly to its pc board. Mechanical support and electrical connection for the 4020 are provided by two plugs (P1 and P2) on the 4020 which mate with two jacks (J1 and J2, respectively) on the 402. Refer to Figure 3 for the option locations of the 4020 and the 402. When the 4020 is provided, screw-type option switches A through D (also shown in Figure 3) must be opened to permit proper loopback operation. When the 4020 is not provided, these option switches must be closed to complete the 4-wire voice path.

Sealing Current

7.02 When the 4020 is provided and sealing current is used, screw-type option switch SC (shown in Figure 3) must be closed to complete the path. Opening SC prevents the flow of sealing current.

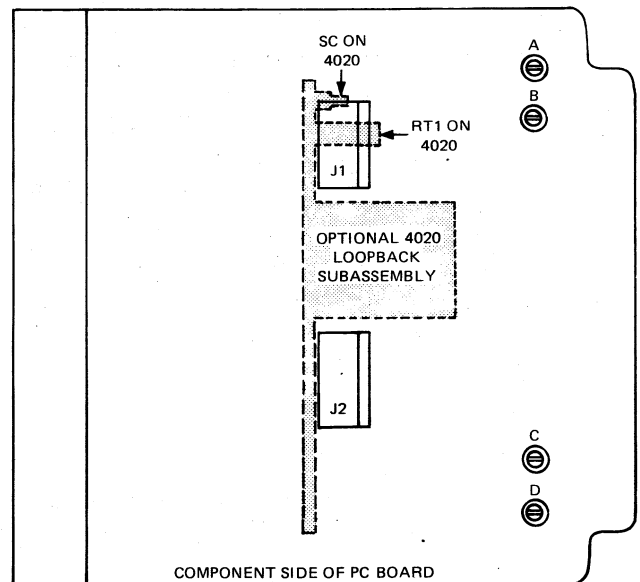

Figure 3. Option Location Drawing for the 402 Module and the 4020 Subassembly

8. ALIGNMENT

8.01 The alignment procedure for the 402 Four-Wire Line Termination Module is performed using two test jacks and a level control located on the front panel. Alignment consists of setting the level of the sidetone applied to the receive drop. Refer to Table 2 for the alignment procedure.

9. TESTING

9.01 Perform a talk test on the facility after completing the installation and alignment to verify proper operation. Request the STC to initiate the loopback condition and to perform a facility check before releasing the loopback condition.

9.02 If trouble is experienced with transmission or reception, verify that all installer connections have been properly connected in accordance with Table 1 and that all option screws have been properly conditioned. Perform the alignment procedure to determine whether the cause of the problem is internal or external to the 402. If the

402 is suspected, replace it with a module known to be in operating condition for verification. If relay LB operates briefly and then releases as the loopback mode is initiated, remove and test resistance lamp RT1 (Figure 3). The filament resistance of RT1 should measure less than 100 ohms on a standard multimeter. If this measurement indicates an open circuit through the filament of RT1, replace RT1 with a similar lamp having a rating of 40mA at 28V. When ordering from Wescom, specify part No. 018-900105. To obtain technical assistance, contact the Wescom Technical Services Department by calling:

(312) 971-2010,
 TWX 910-695-4735, or
 DATAPHONE (312) 971-1698

Canadian Customers:
 (416) 453-2222 or
 TWX 610-492-2697

10. WARRANTY

10.01 **STANDARD WARRANTY:** Wescom products are warranted to be free from defects in material, workmanship, and design given proper

Table 2. 402 Alignment Procedure

Test Equipment Required	
(a)	Transmission Measuring Set (TMS): Hewlett-Packard 3550, WECO 23A, or equivalent with self-contained Variable Frequency Oscillator (VFO).
(b)	Associated Test Cords: Two 2- or 3-conductor test cords equipped with Type 310 plugs at each end.
STEP	INSTRUCTION
1	Adjust the VFO for operation at 1000Hz and a source impedance of 600 ohms. Arrange the TMS for 600-ohm terminated measurement. Connect the VFO to the TMS and set its output for a +2dBm.
2	Disconnect the VFO from the TMS and connect it to the XMT TEST jack on the front panel of the 402 module. Connect the TMS to the RCV TEST jack on the 402 front panel.
3	With power applied to the module, adjust the SIDE TONE LEVEL control on the front panel of the 402 until the TMS reads -15dBm.
4	This completes the alignment procedure for the 402 module; disconnect the TMS and VFO and perform a talk test on the facility.

installation and regular maintenance. Wescom's obligations under this warranty are limited to correction and replacement at Wescom's production facility of any defective items received by Wescom, transportation prepaid, for a period of five years from the date of original shipment. Warranty and remedies on products not manufactured by Wescom are in accordance with the warranty of the respective manufacturer. WESCOM MAKES NO OTHER WARRANTY OF ANY KIND WHATSOEVER, EXPRESSED OR IMPLIED; AND ALL IMPLIED WARRANTY OF FITNESS FOR A PARTICULAR PURPOSE WHICH EXCEEDS THE AFORESAID OBLIGATIONS IS HEREBY DISCLAIMED BY WESCOM.

10.02 Except for the replacement of resistance lamp RT1, field repairs involving the replacement of components within a unit are not recommended. If an item is found to be defective, contact Wescom, Inc., by telephone or TWX, for instructions regarding replacement or repair.

10.03 If a replacement unit is required, it will be shipped in the fastest manner consistent with the urgency of the situation. Upon receipt of a replacement unit, return the defective unit in the carton in which the replacement was shipped, using the shipping label provided, to:

Wescom, Inc.
8245 Lemont Road
Downers Grove, Illinois 60515

Canadian Customers:

Wescom Canada, Ltd.
287 Glidden Road
Brampton, Ontario L6W1H9
Canada

Repair or Exchange Services

10.04 In addition to the standard Wescom Warranty Service, Wescom offers a repair or exchange service for those items out of warranty. Under this arrangement, faulty units may be shipped to Wescom for either complete repair and quality testing or exchanged for a replacement unit. To obtain details of this service and a schedule of prices, contact your local Wescom Sales Representative.

11. SPECIFICATIONS

11.01 The electrical and physical characteristics of the 402 module and 4020 subassembly are as follows:

- (a) IMPEDANCE, TRANSMIT LINE: 600 ohms.
- (b) IMPEDANCE, TRANSMIT DROP: 35 ohms.
- (c) IMPEDANCE, RECEIVE LINE: 600 ohms.
- (d) IMPEDANCE, RECEIVE DROP: 4 ohms.
- (e) INSERTION LOSS (600-OHM MEASUREMENT): Receive, 23dB nominal; transmit, 16dB nominal.
- (f) RANGE, SIDETONE PATH: -12 to -50dB.
- (g) FREQUENCY RESPONSE: ± 1 dB from 300 to 4000Hz.
- (h) LOOPBACK LEVEL: Equal transmission level loopback (23dB pad from +7 TLP in receive path to -16 TLP in transmit path).
- (i) LOOPBACK OPERATE SIGNAL: 20Vdc minimum, polarized such that pin 35 or the transmit path SX lead is positive and pin 31 or the receive path SX lead is negative.
- (j) LOOPBACK CURRENT: 20mA to operate; 14mA to hold.
- (k) LOOPBACK RANGE: 1450 ohms total SX loop resistance (including SCO equipment resistance) with 48V operation.
- (l) SEALING CURRENT: 20mA nominal polarized such that the transmit path SX lead (pin 35) is negative and the receive path SX lead (pin 31) is positive. The direction of current flow for sealing current is opposite to that required to establish the loopback condition.

Section 402/4020-101/3

- (m) **OPERATING ENVIRONMENT:** Temperature, 32° to 120°F (0° to 49°C); humidity to 95% (no condensation).
- (n) **POWER REQUIREMENTS:** Filtered battery, -24Vdc nominal (-21 to -28V limits) at 70mA maximum.
- (o) **WEIGHT:** 402, 8.5oz (241g); 4020, 2.5oz (71g).
- (p) **DIMENSIONS:** Height, 5.6 inches (14.2cm); width, 1.5 inches (3.8cm); depth, 6 inches (15.2cm).
- (q) **MOUNTING:** One module position in a Wescom 400 Mounting Assembly.

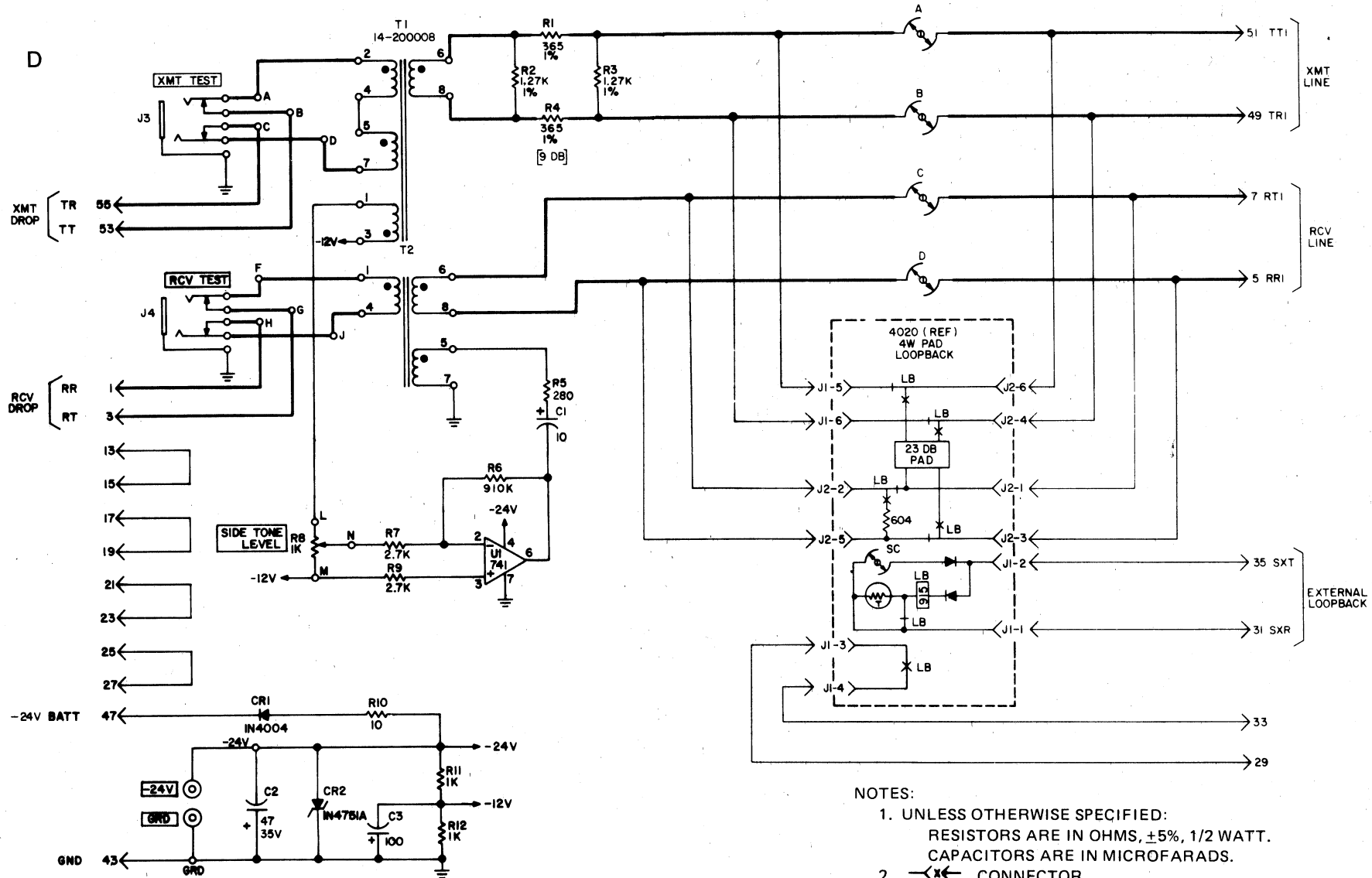

THIS PRINT IS THE PROPERTY OF WESCOM, INC. AND SHALL NOT BE REPRODUCED, COPIED OR USED IN ANY MANNER DETRIMENTAL TO THEIR INTERESTS.

- NOTES:
1. UNLESS OTHERWISE SPECIFIED:
RESISTORS ARE IN OHMS, $\pm 5\%$, 1/2 WATT.
CAPACITORS ARE IN MICROFARADS.
 2. CONNECTOR.
 3. FRONT PANEL TEST POINT.
 4. FRONT PANEL DESIGNATION.
 5. OPEN, CLOSED SCREW OPTIONS.
 6. OPEN A, B, C, D WHEN USING 4W LOOPBACK.
 7. PRIMARY TRANSMISSION PATH.

Figure 4. 402 4-Wire Line Termination Module (Issue 3) and 4020 (Issue 1) Loopback Subassembly Schematic Diagram