

Telephone Apparatus and Cable



CATALOG No 9



Western Electric

Western Electric TELEPHONE APPARATUS AND CABLE CATALOG

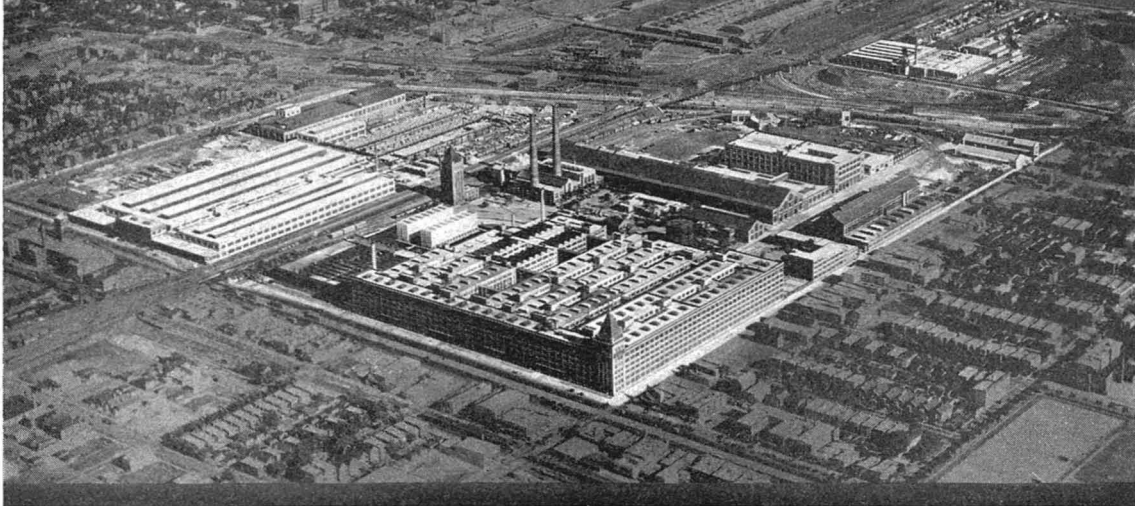
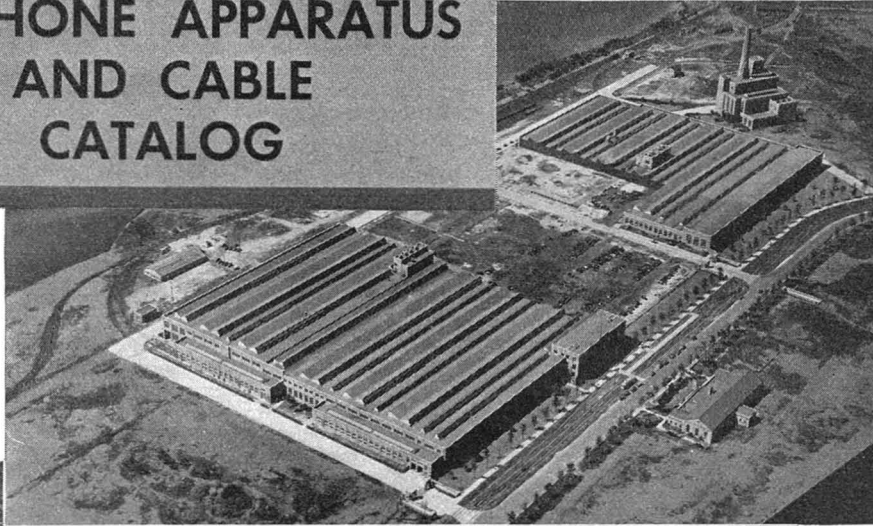

Airplane views of plants in which Western Electric Telephone Apparatus and Cable are manufactured: (top) Point Breeze Works, Point Breeze, Maryland, (center) Kearny Works, Kearny, New Jersey, (bottom) Hawthorne Works, Chicago, Illinois

(See last page for list of distributors)

Copyright, 1930, 1935 by

WESTERN ELECTRIC COMPANY, INCORPORATED

Western Electric Company

History

THE Western Electric Company was organized in 1881 as the successor to the Western Electric Manufacturing Company of Chicago, manufacturers of telephone apparatus. This was just five years after Alexander Graham Bell invented the telephone. The Western Electric Company is therefore the oldest electrical manufacturer in the United States continuously engaged in the production of electrical apparatus.

Factory, Products, Distribution

Telephones, telephone central office equipment and telephone cable have always been the chief products of this company. The main factory which covers 115 acres, is located at Hawthorne, Illinois, six miles from the center of Chicago. Another plant of 145 acres, is located at Kearny, N. J., and a third plant of 125 acres located at Point Breeze, Baltimore, Md. These manufacturing facilities combined with a centralized system of purchasing and inspection enable the Western Electric Company to produce at all times telephone equipment which sets the standard in the field of communication.

Western Electric telephone products are given world-wide distribution through selling organizations maintaining branch houses in the principal business centers. This means that products of this company are readily available everywhere together with the services of specialists who understand the use and application of these products and can supply definite and comprehensive information and assistance to the prospective customer. The worth of such extensive service and cooperation has proven of great value on innumerable occasions.

Accessibility of Permanent Sources of Supply

An important factor to be considered in the purchase of telephone apparatus is the certainty of a permanent source of supply initially, as well as for repair and additional parts. Purchasers of Western Electric equipment are assured of this advantage. As advances in the art of communication make it necessary to develop new types of apparatus, the improved or newly developed equipment, when ready for the market, is made immediately available through the Western Electric Company's domestic and foreign distributors.

Prices

Prices have purposely been omitted from this catalog. They are always as low as possible consistent with the high grade of material, expert workmanship and excellent performance which form the basis of the Western Electric Company's manufacturing policy.

Due to market fluctuations, prices on apparatus listed and on any special equipment that we are in a position to furnish will vary from time to time. Quotations will be furnished upon application to the nearest distributing house (see list on last page of this catalog). Inquiries should clearly describe the apparatus and quantity desired.

Suggestions when Ordering Telephone Apparatus Parts and Supplies

In order to avoid mistakes in ordering parts, please furnish the following information:

- 1st Quantity desired.
- 2nd "P" number of the parts required when this information is available.
- 3rd Name of the part or apparatus required.
- 4th Code number of the part or the apparatus on or in which the part is used.
- 5th Page number and date or number of the catalog in which the part appears.

If the part desired is not shown in the catalog, please furnish the following information:

- 1st Quantity desired.
- 2nd Name of apparatus or part.
- 3rd Code number of part or the apparatus on or in which the part is used.
- 4th If possible, submit a sample of the part desired.

Be sure to place a tag on the sample, giving your name, the name of your company and description of the part wanted: for example: "3 Contact Springs for No. 48A Generator, per sample attached." Address your inquiry or order to any Western Electric distributor, preferably the one located nearest you. Location of distributors will be found on the last page of this publication.

This catalog replaces the 1930-31 Edition.

APPARATUS BLANKS

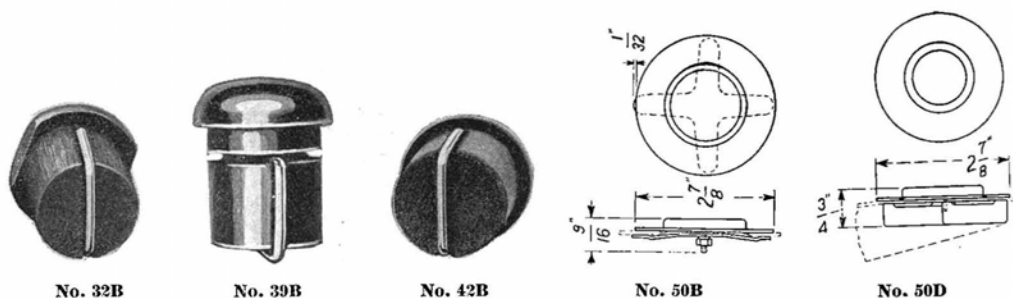

Code No.	Material	Finish	Used
28A	Steel	Black	In unequipped positions of the No. 89D Signal Mountings on the No. 105B Magneto Switchboard.
32B	Birch	Ebonized	In unequipped cord circuit positions of No. 1 Type Switchboards in No. 13 Lamp Socket Drillings.
33B	Birch	Ebonized	In unequipped positions of the No. 109 Plug. Recommended in place of the No. 26 Type.
38B]	Birch	Ebonized	In unequipped cord circuit positions for plugging drillings for Nos. 49, 110, 111 and 117 Plugs and plugs of similar size.
39B	Birch	Ebonized	In unequipped positions of Nos. 2, 8, 55, 56, 60, 61, 65, 71, 72, 91, 99, 102, 103, 104, 107, 108, 109, 110, 117, 118, 123, 124, 126, 127, 128, 134, 136, 139, 140, 151, 153, 154, 155, 156, 159, 160, 165, 172, 174, 175, 176, 177, 178, 184, 188, and 189 and similar Type Jacks. Recommended in place of No. 12 Type.
40B	Birch	Ebonized	For plugging unequipped drillings for the Nos. 16, 33 or 34 Lamp Sockets and No. 92B Keys in the piling rail of toll switchboards arranged for pneumatic tube equipment. Recommended in place of the No. 6 Type.
42B	Birch	Ebonized	In unequipped No. 13 Lamp Socket drillings and Nos. 22, 27, 32, 37, 53, 65, and 78 Plug drillings. Recommended in place of the No. 7 Type.
50B	Metal	Black	To clamp on No. 553 Type Subscriber Sets to cover unequipped dial positions when sets are used in manual service.
50C-3	Metal	Black	To mount on Nos. 50 or 150 Type Coin Collectors to cover unequipped dial position when coin collector is used in manual service.
50C-13	Oxidized	Bronze	Same as 50C-3.
50D	Metal	Black	To clamp on No. 50 Type Desk Stand to cover unequipped dial position when stand is used in manual service.
50E	Metal	Black	To clamp on Nos. 51 or 151 and similar Type Desk Stands to cover the unequipped dial position when the stand is used in manual service. Provided with an insulating block having two screw terminals to which may be attached the leads which are ordinarily connected to the dial.
*50H-3	Metal	Black	To clamp on "B" and "E" Type Handset Mountings to cover the unequipped dial position when the mountings are used in manual service. Provided with card holders. For replacement parts see "Handset Mountings."
*50J-3	Metal	Black	To clamp on "D" Type Handset Mounting to cover the unequipped dial position when the mounting is used in manual service. Provided with card holder. For replacement parts see "Handset Mountings."

* May also be obtained in Ivory, Gray, Old Brass, Statuary Bronze, Oxidized Silver, Medium Gold and Dark Gold Finish.

Western Electric
BACKBOARDS

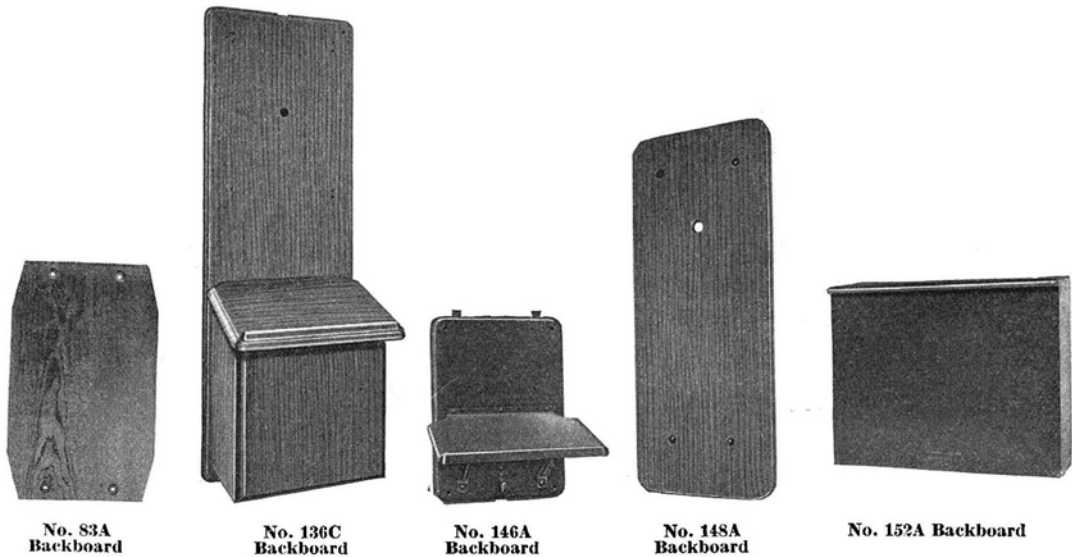

Code No.	Description and Principal Use	Overall Dimensions, Ins.
79	Wood, black finish. Used to facilitate mounting No. 58 Type Protectors on brick or stone walls.	12½ x 5 x 1⅜
82A	Wood. For mounting miscellaneous apparatus in the H202 Cable Terminal Section. Provided with screws and washers for mounting.	37¾ x 5 x ¾
82B	Wood. For mounting miscellaneous apparatus in the H303 and K606 Cable Terminal Sections. Provided with screws and washers for mounting.	55⅝ x 7 x ¾
82C	Wood. For use in K606 Cable Terminal Section to cover exposed ends of the wiring rods and also for mounting miscellaneous apparatus. Provided with screws, nuts and washers for mounting.	55⅝ x 12 x ¾
82D	Wood. For mounting miscellaneous apparatus in H102 Cable Terminal Section. Provided with screws and washers for mounting.	21⅜ x 6¾ x ¾
83A	Wood. Equipped with a distributing ring at each end. For mounting "H" Type Binding Post Chambers and "L" Type Cable Terminal Sections. Part of LA16 Cable Terminal.	18⅞ x 11¼ x 2⅞
83B	Same as 83A, except forms part of LA26 Cable Terminal.	25⅞ x 11¼ x 2⅞
83C	Same as 83A, except forms part of LA51 Cable Terminal.	45⅜ x 11¼ x 2⅞
136B	Wood, oak finish. Arranged with battery box for 3 dry cells. Used with No. 1293 and No. 1305 Type Telephone Sets. Top of battery box forms writing shelf.	26 x 8⅛ x 7⅜
136C	Wood, black finish. Arranged with battery box for 3 dry cells. Used with Nos. 1293, 1533 and 1553 Type Telephone Sets. Top of battery box forms a writing shelf.	24⅝ x 8⅛ x 7⅛
144C	Wood, black finish. Intended for mounting a No. 150 Type Coin Collector and a No. 334, 534, 584 or 684 Type Subscriber Set. The coin collector mounts above the subscriber set. Replaces the Nos. 144B and C Backboard	27⅝ x 7¼ x ¾

BACKBOARDS—Continued

Code No.	Description and Principal Use	Overall Dimensions, Ins.
146A	Black finished metal Backboard with writing shelf: for use with Nos. 533, 534, 553 and 554 Type Subscriber Sets where a writing shelf is required. Replaces the No. 143A Backboard.	9 $\frac{1}{2}$ x 7 $\frac{1}{2}$ x 6 $\frac{3}{16}$
147A	Wood, black finish. Drilled for Nos. 333, 334, 533, 534, 553 and 554 Type Subscriber Sets where it is desired to insulate them or facilitate mounting on brick or irregular surfaces.	9 $\frac{9}{16}$ x 7 $\frac{1}{8}$ x 9 $\frac{1}{16}$
148A	Wood, black finish. Drilled for Nos. 333, 334, 533, 534, 553 and 554 Type Subscriber Sets together with Nos. 7A and 7J Coin Collectors; also drilled for use with Nos. 333, 533 and 553 Type Subscriber Sets in combination with a No. 146A Backboard.	18 $\frac{13}{16}$ x 7 $\frac{1}{8}$ x 9 $\frac{1}{16}$
150A	Wood, black finish. Used with No. 7A and No. 7J Coin Collectors, where it is desired to insulate them from the walls or mount them on brick or other irregular surfaces.	8 $\frac{11}{16}$ x 6 $\frac{1}{8}$ x 5 $\frac{5}{8}$
152A	Green finished wood with removable front cover. For use in mounting Nos. 292 and 392 Type Extension Bells. Replaces the No. 149A.	15 x 13 x 6 $\frac{9}{16}$
153A-3	Black finished metal backboard. Intended for use in mounting the Nos. 50 or 150 Type Coin Collector in the corner of a telephone booth.	17 $\frac{7}{8}$ x 7 $\frac{9}{16}$ x 3 $\frac{29}{32}$
153A-13	Same as 153A-3 except finished in oxidized bronze.	17 $\frac{7}{8}$ x 7 $\frac{9}{16}$ x 3 $\frac{29}{32}$
154A	Black finished wood backboard. Intended for use in mounting the No. 584 and No. 684 Type Subscriber Sets on brick walls and metal partitions.	7 $\frac{11}{16}$ x 6 x 5 $\frac{5}{8}$
155A	Black finished metal plate. For mounting the No. 534 and No. 634 Type Subscriber Sets on base boards.	12 $\frac{3}{8}$ x 6 $\frac{13}{16}$ x 3 $\frac{5}{16}$
157A	Black finished wood backboard. For mounting telephone directory hangers on surfaces which do not permit secure mounting of the hangers directly on the surfaces.	4 x 3 x 3 $\frac{3}{4}$

BELLS

NO. 7 TYPE—A.C. OR D.C. OPERATION

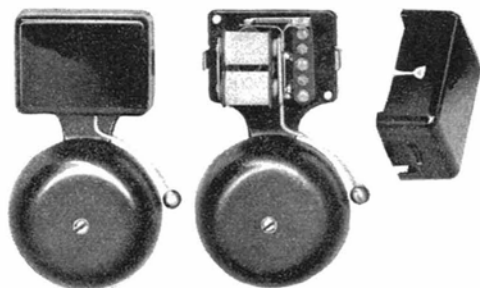

No. 7 Type Bell

The No. 7 Type Bell consists essentially of two coils connected in series on a reed mounted armature and a clapper provided with a circuit interrupting member and having a separate cantilever type retractile spring and three screw terminals. These are all mounted on a black finished base and enclosed by a black finished metal cover fastened to the base by spring clips. The base is provided with two holes for mounting purposes and has a projection on which a No. 20 gong is mounted.

The three terminals permit connections for either A.C. or D.C. operation. When operated on alternating current, connections are made

directly to the coils eliminating the use of the make and break contact. These Bells are equipped with heavy contact points of platinum or No. 2 contact metal. Overall dimensions approximately 5 $\frac{1}{2}$ " x 3 $\frac{1}{2}$ " x 1 $\frac{1}{2}$ ".

Code No.	Total Approx. Resistance Ohms	Operating Voltage D.C.		Operating Voltage 60 Cycles A.C.	
		Min.	Max.	Min.	Max.
7A	245	14	40	25	50
7C	2.5	2	8	3	6
7D	15	4	15	6	18
7E	100	10	20	18	30
7F	680	20	60	35	60

BINDING POSTS

No. 1A



No. 2A

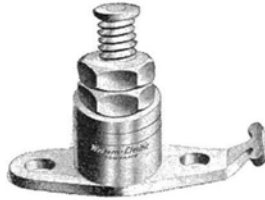

No. 2E



No. 3A



No. 37A



No. 16A



No. 20A



No. 29A



No. 30A



No. 33D



No. 44A

Code No.	Finish	Description
1A	Brass lacquered	Arranged for tubular tips. Thumbscrew connection. No soldering terminals.
2A	Nickel	Lock nut connection. One back soldering terminal.
2C	Nickel	Similar to the No. 2A but with wing nut instead of lock nut.
2E	Brass lacquered	Lock nut connection. One front soldering terminal.
3A	Nickel	Arranged for tubular tips. Lock nut connection. One back soldering terminal.
16A	Nickel	Arranged for tubular tips. Screw connection. No soldering terminals.
20A	Nickel	Arranged for tubular tips. Screw connection. One front soldering terminal.
29A	Tinned	Used in Nos. 8 and 14 Type Cable Terminals when original binding post is broken off above the lower nut. For 10-32 thread only.
29B	Tinned	Used in Nos. 8 and 13 Type Cable Terminals and the Nos. 6 and 10 Type Connecting Blocks when the original binding post is broken off above the lower nut. For 8-32 thread only.
30A	Tinned	Screw connection. One front soldering terminal.
33D	Black	Insulated post. One back soldering terminal.
37A	Brass lacquered	Screw connection. One front soldering terminal.
44A	Nickel	Wing nut connection. One front soldering terminal.
45A	Black	Insulated post. For mounting on $\frac{1}{4}$, $\frac{3}{8}$ and $\frac{1}{2}$ inch panels. Screws for mounting on $\frac{1}{4}$ in. panel furnished unless otherwise specified.

BATTERY BOXES



No. 1A Battery Box

The Nos. 1 and 2 Type Battery Boxes provide a neat and convenient means of mounting dry cells and protecting them from injury. These boxes are made of sheet metal finished with black japan and are lined with insulating material. Pear shaped mounting slots in the back of the boxes provide an easy means of mounting on vertical surfaces and in such a way that they are readily removable. This feature permits of their being located at the sides or under desks and in other places where they will be out of the way and adjacent to the telephone or other apparatus to which they are connected and yet be accessible for maintenance purposes.

Code No.	Dry Cell Capacity	Dimensions Inches
1A	3 No. 6 cells	$3\frac{1}{4} \times 7\frac{15}{32} \times 9\frac{7}{16}$
2A	4 No. 6 cells	$3\frac{7}{32} \times 7\frac{3}{8} \times 12\frac{19}{64}$
2B	9 No. 6 cells	$5\frac{23}{32} \times 7\frac{7}{16} \times 14\frac{5}{32}$

BATTERY CONNECTOR

No. 540 Cord

This is a stranded conductor battery connector for connecting dry cells equipped with Fahnestock clips. It insures freedom from short circuits due to poorly insulated conductors, saves time in connecting, and gives the battery a neat appearance.

Code No.	Description
540	Standard length 5 inches. The moisture proofed cotton insulation is cut back at each end $\frac{5}{8}$ of an inch and the bare stranded conductor soldered to prevent fraying.

BOOTH SWITCHES

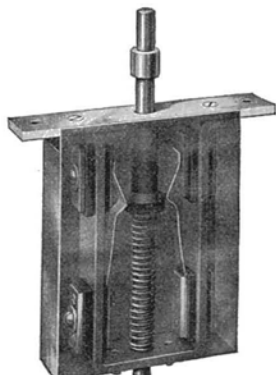

No. 1A Booth Switch

Code No.	Description
1A	This switch is used for disconnecting a telephone, located in a booth or pole-box, from the line when the booth or pole-box is locked. It operates when a hasp is placed over the staple, and held in place by a padlock. It guards the telephone set against injury from lightning discharges. The approximate dimensions of the switch case are: width, $3\frac{1}{2}$ ins., depth 1 in., and length, $4\frac{1}{2}$ ins.

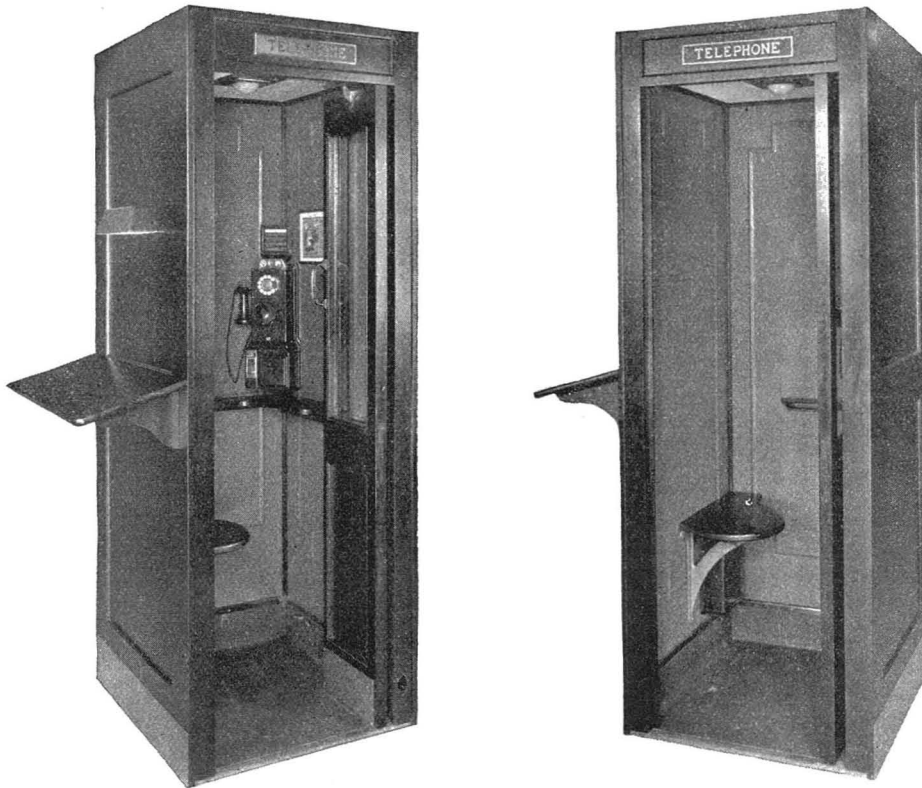
BOOTHS—TELEPHONE**Nos. 5 and 6 Type Telephone Booths**

No. 6 Type Telephone Booths, equipped with accessory equipment—No. 11 Type Directory Shelf, No. 2A Directory Light Fixture and No. 10 Telephone Sign.

The Nos. 5 and 6 Type Telephone Booths present a very pleasing appearance. They are of the same construction except that the No. 5 is arranged for use without a seat and the No. 6 is equipped with a seat. For use in single or multiple installations. Overall dimensions: height, 83 inches; width, $28\frac{3}{4}$ inches; depth, 30 inches.

The features and equipment of these booths are outlined below.

Ventilation: These booths are arranged to provide ventilation when the door is closed. The air enters at the bottom of the door and passes out through openings in the light fixture or blank. In booths with the light fixture, ventilation is further improved by the heat from the lights.

Exterior: Bronze plates are placed at the bottom of the sides and back of the booth for protection of the outside of the booth against the effect of cleaning fluids or mechanical injury.

Interior: Metal lining of a new panel design.

Floor: The floor is substantially flush thus facilitating entrance to and exit from the booth. It is of heavy galvanized steel, which makes for a rigid construction of the booth, and is covered with rubber of a black and white marble pattern. The rubber flooring in one piece is carried up the sides to form baseboards for the protection of the inside of the booth against the effects of cleaning fluids or mechanical injury. Bronze finished moldings are used on the sides and back to protect the upper edges of the rubber.

Door: The construction of the door is such that it does not project materially outside the booth when in the open position. The bottom of the door panel which is exposed when the door is open is protected by a bronze kick plate. Bevel glass windows and bronze door handles and hinges add to the general appearance of the front of the booth.

BOOTHS—TELEPHONE—Continued

Threshold: A door tread of wear resisting metal, the appearance of which harmonizes well with the general booth appearance, extends completely across the booth. The tread is beveled over the rubber flooring to prevent the rubber from being kicked up from the metal floor.

Mounting for Coin Collector: A triangular iron mounting, coded 153A Backboard, is provided as a part of the booth, to mount the coin collector diagonally in the rear right-hand corner. This arrangement utilizes to the best advantage the space available. It also makes possible the mounting of the standard 1B Instruction Card Holder in a more desirable position.

Shelf: Due to the arrangement of the coin collector provision is made for a shelf, coded No. 10 Type Shelf, adapted for writing as well as an elbow rest.

Lighting: Lighting for the booth and the instrument is provided from a fixture, coded No. 1A Light Fixture, of pleasing appearance mounted in the ceiling. The operation of the light is affected by a new and improved type of switch, the operating mechanism of which is concealed above the ceiling. As a further aid to the lighting of the booth the ceiling is finished in white. To guard against unauthorized removal of the light bulb a lock is provided.

Where it is desired that the booths be not equipped for lighting, the lighting fixture is replaced by a booth light blank of the same general design but without the glass lens. Provision is made for the subsequent addition of the lighting fixture.

Booths will be furnished with lighting equipment unless otherwise specified.

Wiring: To facilitate installation, the booths will be pre-wired for the coin collector, bell box and light. When a light fixture is not furnished the light wiring is omitted.

Code Number		Wood	Finish	Back
Without Seat	With Seat			
5-A	6-A	Mahogany	Medium Dull Mahogany	Mahogany
5-B	6-B	Mahogany	Medium Dull Mahogany	Softwood
5-C	6-C	Oak	Medium Dull White Oak	Oak
5-D	6-D	Oak	Medium Dull White Oak	Softwood
5-E	6-E	Mahogany	Dark Dull Mahogany	Mahogany
5-F	6-F	Mahogany	Dark Dull Mahogany	Softwood
5-G	6-G	Mahogany	Medium Dull Walnut	Mahogany
5-H	6-H	Mahogany	Medium Dull Walnut	Softwood
5-J	6-J	Walnut	Medium Dull Walnut	Walnut
5-K	6-K	Walnut	Medium Dull Walnut	Softwood
5-L	6-L	Mahogany	Unfinished	Mahogany
5-M	6-M	Mahogany	Unfinished	Softwood
5-N	6-N	Oak	Unfinished	Oak
5-P	6-P	Oak	Unfinished	Softwood
5-R	6-R	Walnut	Unfinished	Walnut
5-S	6-S	Walnut	Unfinished	Softwood

The above code numbers do not include the end panels, coded No. 51 Type Panels, which are required for both single and multiple installations or separators, coded No. 1 Type Separators, that are required for multiple installations. Orders should specify the number of end panels and separators required.

The code letters A, C, E, G, J, L, N, and R have been assigned to cover the various woods and finishes of the No. 51 Type Panels, No. 1 Type Separators, No. 10 Type Writing Shelves, No. 11 Type Directory Shelves and No. 101 Type Seats. These code letters cover the same woods and finishes as the corresponding code letters of the Nos. 5 and 6 Type Booths and indicate that these parts are for use with the telephone booths bearing the same code letter and the next letter in alphabetical order. For instance, the No. 51A Panel, No. 1A Separator, Nos. 10A and 11A Shelves are used on both the No. 5-A and No. 5-B, also No. 6-A and No. 6-B, Telephone Booths.

Booths will be furnished with lighting equipment unless otherwise specified.

ACCESSORY EQUIPMENT

Material	Use
No. 11 Directory Shelf *	Directory shelf for mounting on booth end panel.
No. 2A (Directory) Light Fixture	Directory lighting fixture for mounting on end panel above directory shelf. Includes light socket and length of cable.
No. 10 Telephone Sign per KS6467	Bronze sign with word "Telephone."
Card Frame per KS6486	Bronze frame for advertising cards for mounting on inside wall of booth.

* The finish required should be specified.

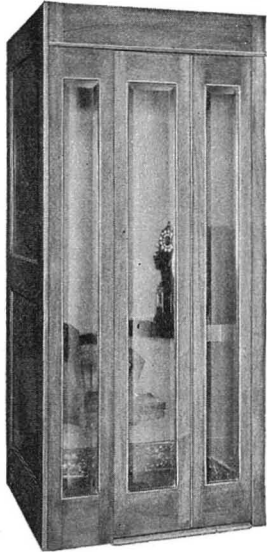
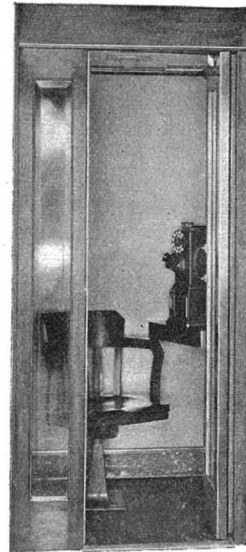
BOOTHS—TELEPHONE—Continued**No. 7 Type Telephone Booth****No. 7 Type Telephone Booth****No. 7 Type Telephone Booth, Door Open**

The No. 7 Type Telephone Booths are similar in construction to the Nos. 5 and 6 Type Booths having the same height except for the ventilator cowl on the roof but with the width $8\frac{1}{8}$ " greater and the depth 6" greater. They are intended for use in locations such as clubs and hotel lobbies.

The door which folds inside the booth when opened consists of two vertical sections with full length beveled plate glass panels in each section.

The interior of the booth is equipped with a smooth lining having a gold and brown mottled finish. The booth is equipped with a revolving non-reclining arm chair and ceiling light, shelf, ventilating fan and grill and a backboard for mounting the coin collector. Telephone wiring is provided for the coin collector and the subscriber set and power wiring for the light and fan. The light is turned on and off and the fan started and stopped by means of a switch which is actuated by the opening and closing of the door.

Booths will be furnished completely assembled unless the order specifies otherwise. When shipped unassembled, the switch, light fixture, fan and grill are assembled to the ceiling.

DIMENSIONS: The overall dimensions are as follows:

Height	Width	Depth
7' 1"	3' 1"	3'

Booths are arranged for use singly or in groups or in conjunction with other booths of the same type or with standard Nos. 5 and 6 Type Telephone Booths.

Two No. 55 Type Panels are required with each single booth or group of booths. No. 2 Type Separators are required for use between booths when two or more are used in a group. The panels and separators do not form a part of the booth and must be ordered separately.

EXTERIOR: The exposed exterior surfaces of these booths are made of mahogany. The finish and material of the backs and the finish of the booths are as follows:

Code No.	Back	Finish
7A	Mahogany	Medium Dull Mahogany
7B	Softwood	Medium Dull Mahogany
7E	Mahogany	Dark Dull Mahogany
7F	Softwood	Dark Dull Mahogany
7G	Mahogany	Light Dull Walnut on Mahogany
7H	Softwood	Light Dull Walnut on Mahogany
7L	Mahogany	Unfinished
7M	Softwood	Unfinished

Note: Mahogany backs are equipped with a metal kick plate.

BUZZERS FOR ALTERNATING CURRENT

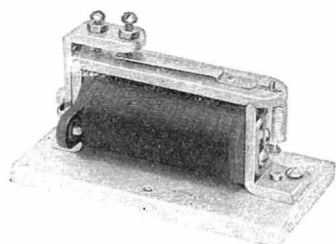

No. 4C
Cover Removed

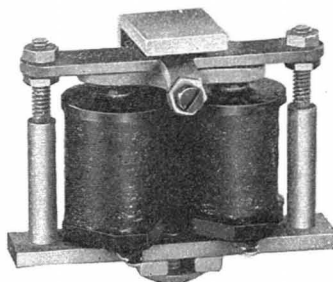

No. 5A
Buzzer

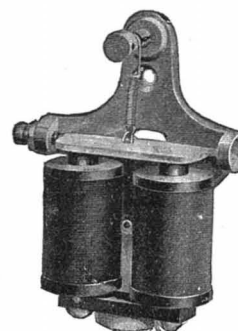

No. 2D
Buzzer

Code No.	Resistance Ohms	Type	Dimensions Inches	Principal Use
2C	1000	Not polarized	2 ²⁹ / ₃₂ x 2 ¹ / ₄ x 2 ⁷ / ₃₂	Test Sets.
2D	100	Not polarized	2 ²⁹ / ₃₂ x 2 ¹ / ₄ x 2 ⁷ / ₃₂	No. 1017 Type Test Sets.
2E	100	Not polarized	2 ²⁹ / ₃₂ x 2 ¹ / ₄ x 2 ⁹ / ₃₂	Test Sets.
4B	1200	Not polarized	3 ¹¹ / ₁₆ x 1 ¹⁵ / ₁₆ x 2 ¹ / ₄	P.B.X. Switchboards. Operates on A.C. ringing current of 16 ² / ₃ cycles.
4C	1200	Not polarized	3 ²⁵ / ₃₂ x 2 ¹ / ₄ x 2 ⁵ / ₁₆	P.B.X. Switchboards. Operates on A.C. ringing current of 16 ² / ₃ cycles, also on 24 volts D.C. Has a dust-proof cover.
5A	2150	Polarized	2 x 2 ¹⁵ / ₃₂ x 1 ⁹ / ₁₆	Operates on 90 volts. 375B Subscriber Set.

CIRCUIT BREAKER

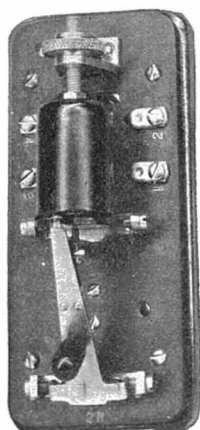

No. 2B Circuit
Breaker

Code No.
2B

Description

A small overload circuit breaker consisting of an armature, coil and breaker arm, mounted on a black phenol fibre base measuring 2¹/₂ x 5⁵/₈ inches. To be mounted vertically. The action of the coil and armature releases the arm, which is actuated by a spring, breaking the main circuit and instantaneously making a secondary circuit for ringing an alarm by bringing together two contact springs mounted underneath the base.

The air gap between the core and the armature is adjusted so that the circuit breaker opens reliably at .6 amperes and does not open on .5 amperes. Has coin silver contacts.

It acts quicker than a fuse and can be reset.

Replaces No. 2A Circuit Breaker.

1A ELECTRIC CLOCK

The 1A Electric Clock is arranged to mount in a switchboard keyshelf in a vertical position and gives time in hours, minutes and tenths of minutes. Is equipped with a black finished cover having a celluloid window. Is operated electrically by means of a master clock on 24 volts.

Approximate Resistance (Ohms)	Operating (Ampere)	Non-Operating (Ampere)
500	.028	.020

LEAD COVERED CABLE**A Development of Bell Telephone Laboratories, Incorporated, the Research Laboratories of the American Telephone and Telegraph Company and the Western Electric Company**

With the present multiplicity of telephone lines and the limitations of space wherein to run them, their enclosure in pipe-like covering is a logical method.

A number of advantages follow automatically. Some maintenance costs inherent in open wire construction disappear, others go down, while the protection afforded the wires tends to make the availability of the wires for service practically continuous.

Furthermore, as ease of handling is essential to secure economy of labor, the need of flexibility in the sheathing is apparent: Lead meets these requirements and is, therefore, used sometimes alone and sometimes in an alloy.

These conditions led to the development of Lead Covered Cable, and as its advantages were recognized, it took its place in telephone plants as a necessity.

WESTERN ELECTRIC LEAD COVERED CABLE

This cable in its present form, whether for aerial use, in ducts underground, or for inside use, in its simplest and most usual form, requires for its manufacture three principal raw materials—copper for the wire or conductors; paper for their insulation and pure lead or an alloy of lead and antimony for the sheath.

CABLE ENGINEERING ESSENTIAL

Early in its manufacturing experience with Lead Covered Cable the Western Electric Company realized that such cables must be engineered, not simply built. Engineering is essential to make lead covered cable:

- that will transmit currents with minimum dielectric losses;
- that will prevent current in one line from interfering with the current on another.

Engineers must select the requirements for good cable and work out the methods for determining if the materials and means of manufacture measure up to the requirements. The skill of the cable-makers directly affects the quality of the cable, and that skill must be of the highest order. The cable will meet service conditions and last a reasonable length of time:

- if the raw material is the most suitable;
- if the insulation of the conductor is uniform and if the insulated conductors are properly twisted into pairs to eliminate any audible cross talk that would interfere with the clear transmission of messages;
- if the laying of the paired conductors is of the evenness necessary to assure flexibility and therefore economy of time and labor when handling the cable;
- if the ovens for drying out the cable are suitable;
- if the methods for handling the cores from oven to sheathing machines prevent moisture entering the cable en route;
- if the design of the cable is such as to insure ease of handling without tendency to buckle on account of too great softness.

ADVANTAGES

As a means to practically uninterrupted communication, Lead Covered Cables offer a number of conspicuous advantages, making for better service, better public relations and money economies.

Western Electric Lead Covered Cable possesses several advantages of material benefit to its users. These advantages are:

1. They make use of the most suitable designs and materials to secure and maintain the highest class of telephone transmission, as determined by many years of research work conducted by Bell Telephone Laboratories, and by constant tests in the field, in close cooperation with the largest users of telephone cable in the world.

2. The reliability of the Western Electric product is proven by the fact that more than half the telephone cable in use throughout the world is of Western Electric design.

LEAD COVERED CABLE—Continued

3. Cables are manufactured by the Western Electric as an essential part of the telephone plant which must not only give the most efficient performance possible, but must maintain this efficiency through the greatest possible number of years. To accomplish this object, every part of telephone cable is designed not only to give the electrical qualities required, but to insure a maximum of mechanical ruggedness and protection against damage. As an example of this, a given mutual capacitance can be obtained in either a soft core or a hard core cable, the hard core cable being somewhat larger in diameter and containing a larger amount of insulating paper. The former, however, is bound to be soft or "mushy" to such an extent that it has a decided tendency to buckle when bent, and it is therefore more difficult to install than the harder core cable. Western Electric cables are designed to have satisfactory mechanical characteristics.

SOME ECONOMIES OF LEAD COVERED CABLE

Cable minimizes interruptions due to storms. Even with improved methods of pole line construction and high-grade line materials, a heavy sleet storm accompanied by a severe gale is more apt to cause trouble with open wire lines than with cable. Such storms are apt to be expensive, and at times some damage is inevitable; but even at the worst, the expense for repairs will generally be less with cable. There are no tangled masses of wires to be cleared, less labor is required during reconstruction, and less material is needed for replacement of damages. Moreover, broken poles frequently do not mean a broken cable or lines in trouble.

There are other expenses than for material, expenses not so easily figured.

First of all, "lines down" means interrupted service, and interrupted service cuts off revenue.

Secondly, "lines down" means dissatisfied customers. Aside from the fact that dissatisfied customers are a liability, the telephone industry has grown and prospered because it has realized that the interests of the public must be and are the interests of the telephone industry. Wherever enough lines are concentrated to make cable economically practicable, its use should be considered.

Finally, the use of cable reduces the ordinary expense of maintenance. Overhead wires in large groups are unwieldy from a maintenance point of view. When the lines are enclosed and protected by lead covered cable, whether aerial or underground, "opens," "crosses," and "tree-grounds" are minimized.

Thus from the standpoint of economy and utility, lead covered cable is advantageous, where transmission conditions will permit its use. A variety of Western Electric Lead Covered Cables are available to meet the requirements imposed by the many ways in which it is used.

PRELIMINARIES

Before laying lead covered cable, it is only a safe and sensible precaution, unless the cable is in short lengths, to survey the proposed route of the cable to search for currents which might cause electrolysis. After a cable is laid, too, similar surveys should be made annually to locate any currents that changes in the character of the locality might have introduced. Railroad electrifications, trolley lines and rearrangements of power lines, can, any or all, be destructive agencies, if not noted and guarded against.

EXTRA PAIRS

Extra pairs are placed in all cables containing conductors smaller than No. 16 to take care of any pairs which may become defective in manufacture. In the majority of cables all or part of the extra pairs will often be found good and may be used for additional circuits. All pairs of No. 16 A.W.G. and larger except in submarine cable are guaranteed to meet the specification requirements when the cable leaves our factory.

The coding of all cables is on the basis of the actual number of pairs. Actual and guaranteed numbers of pairs in the various sizes of standard cables containing conductors smaller than No. 16 A.W.G. are as follows:

Actual Pairs	Guaranteed Pairs	Actual Pairs	Guaranteed Pairs
6 to 149	Actual pairs less one	450 to 505	Actual pairs less five
150 " 249	" " " two	606	" " " six
250 " 349	" " " three	909	" " " nine
350 " 449	" " " four	1212	" " " twelve
		1818	" " " eighteen

TRANSMISSION

The transmitting efficiency of telephone cable, considered as a separate unit, depends principally upon its capacitance and conductor resistance. When telephone cable forms a portion of a completed telephone connection, the transmitting efficiency of the telephone connection as affected by the cable portion depends somewhat on the relative position of the cable in that circuit and also by the type of other construction to which it is connected.

LEAD COVERED CABLE—Continued

The following data are based upon average standard conditions, and may be used for approximate calculations. In the case of circuits involving several different types of construction, we recommend consulting our engineers.

A length of circuit which, when connected to short subscribers' loops, will cause a transmission loss of about 30 db (units of transmission loss, called decibels) is considered about the maximum length over which commercial transmission can be secured.

One db represents approximately the loss found in the following:

- 3.2 miles of No. 12 B.W.G.—B.B. galvanized iron circuit.
- 4 miles of No. 10 B.W.G.—B.B. galvanized iron circuit.
- 8 miles of No. 14 N.B.G. or No. 12 A.W.G. hard drawn bare copper circuit.
- 13 miles of No. 12 N.B.S. hard drawn bare copper circuit.

It then follows that 96 miles is about the theoretical commercial limit for No. 12 B.W.G.—B.B. galvanized iron wire circuit.

Under each listing is given the respective transmission loss or attenuation in db per mile of cable.

CAPACITANCE

The capacitance of a cable circuit is important because it limits to a large extent the length of cable through which it is possible to transmit speech. The capacitance may be specified either as mutual, that is, the capacitance between the two wires or a pair; or as grounded, that is, the capacitance between a wire and all the other wires and the sheath. Mutual capacitance is preferable in defining the quality of the cable for telephone transmission, since the conductors are used in pairs as metallic circuits and seldom, if ever, singly as grounded lines. The grounded capacitance is about 1.6 times the mutual, but this ratio varies somewhat for different cables.

Capacitance may be measured by the d.c. charge method, the d.c. discharge method, or the a.c. method. The a.c. method, using a frequency of 800 cycles or higher, is preferable because it measures the true capacitance for the voice currents. The d.c. capacitance tends to be higher than the a.c. capacitance, and in specifying capacitance this fact should be recognized. The d.c. charge method is less subject to error due to improper manipulation of the testing equipment than the d.c. discharge method, and is therefore a more desirable testing procedure for d.c. testing.

Western Electric Cables are tested for mutual capacitance by the a.c. method, unless specifically requested otherwise.

TYPES OF CABLE

Lead covered cables may be divided into three general classes as follows:

1. Paper Insulated Cable for aerial or underground use. (Lead Covered or Lead Covered and Jute Protected or Lead Covered and Steel Tape Armored.)
2. Paper Insulated Cable, Submarine or Gully Type. (Lead Covered, Steel Wire Armored.)
3. Textile Insulated Cable.

I. AERIAL OR UNDERGROUND CABLE**Lead Covered**

Under the usual conditions of installation of telephone cables the same type of cable may be used for aerial construction or in ducts underground. Until recently plant practices have called for somewhat higher dielectric strength for cables for aerial use. Actual experience, however, has shown that this special requirement is not warranted, and the same cable is now being furnished for either use, resulting in economies not only in cost of the cable but in smaller stocks required. The various types of lead covered cable for aerial or underground use are as follows: NH, AST, BPA, CSA, CSM, and CNB.

Tape Armored

There are many situations where cables buried directly in the ground would offer advantages over other forms of construction. The life of unprotected cable sheath may be very short, depending upon the particular soil conditions. To meet this need, the Western Electric Company have developed a type of covering for the cable sheath which effectively protects the sheath from soil corrosion. This protection consists of wrappings of paper and jute which have been thoroughly impregnated with preservative compound and which are thoroughly flooded with asphaltic compound while being applied to the cable. Cables having this type of covering are referred to as jute protected. In cases where somewhat more mechanical protection is desired or where some protection against low frequency induction from power lines is desired, a steel tape armor can be furnished. This type of sheath covering is similar to that used for the jute protected cables except for the addition of the steel tapes and a further covering of asphalt flooded jute.

Galvanized Tape Armored

Western Electric can furnish galvanized tape armored lead covered cable for aerial use. If your condition necessitates this type of cable, write our nearest distributor giving full details and information and price will be furnished.

Jute Protected

Jute protected cables are about $\frac{3}{32}$ inch larger in overall diameter than the unprotected cables for the smaller sizes and about $\frac{1}{32}$ inch larger for full size cables. For the tape armored cables, the increase in diameter varies with the size of the cable from about $\frac{1}{4}$ inch to about $\frac{3}{16}$ inch. Any lead covered cable can be furnished either jute protected or tape armored if so noted on the order.

LEAD COVERED CABLE—Continued**Paper Pulp Insulation**

A new form of paper insulation has been developed by the Western Electric Company which is known as pulp insulation because of its method of application to the wire. The paper is made directly on the conductor in such a way as to form a continuous, seamless tube.

A new method of constructing cable cores, known as the multiple unit design, has also been developed by the Western Electric Company. Units of 50 or 100 pairs are first separately stranded and then these units are cabled together to form the completed core. This construction offers a distinct advantage in splicing in that the color groups are units and require practically no time for separating in preparation for splicing.

No. 26 gauge cables, coded as Type "AST", No. 24 gauge cables, coded as Type "CSM", and No. 22 gauge cables, coded as Type "CSA", are now regularly furnished with pulp insulation for all sizes and with the multiple unit design in sizes of 152 pairs and larger.

2. SUBMARINE AND GULLY TYPE CABLE, WIRE ARMORED**Submarine**

Paper insulated submarine and gully type telephone cable may be divided into three general classes, depending upon the use for which they are intended.

1. High dielectric strength, tight core cable, designed for use in comparatively long lengths, where the cost of repairing a break in the cable will be less than the cost of an entirely new cable.

2. High dielectric strength, loose core cable, designed for use in comparatively short lengths, where high transmission efficiency and high dielectric strength are of importance; for example: a short crossing cable connecting important open wire.

3. Single paper insulated loose core cable designed for use in comparatively short lengths where so high a dielectric strength is not necessary; for example: a short crossing cable connecting land cables.

Either single or double armored cable can be furnished. In many cases, single armor gives sufficient mechanical protection. Double armor is used only in cases of extremely severe mechanical requirements. In still water with a mud bottom, single armor will be sufficient. With a rocky or uneven bottom, or with strong tides or currents, double armor should be considered.

Gully Type

There is also available a light wire armored cable for crossing gullies, small streams and swamps that may lie along the route of a buried cable. This cable provides greater mechanical strength than the tape armored cable and is lighter and less expensive than the standard wire armored submarine design.

3. TEXTILE INSULATED CABLE (TERMINATING)

Paper insulated cables are usually terminated in buildings by splicing on a short piece of textile insulated cable. Commercial textile yarns are liable to contain soluble salts, which will cause electrolytic action when exposed to moist atmospheres and result in poor insulation and sometimes produce corrosion of the conductors. It has been found that by removing such impurities substantial improvements of the insulating properties of the textiles are obtained. Only purified textiles are used in Western Electric Cables.

The uses of the several types of textile insulated cables listed in the tables following are discussed briefly below.

Types "FA" and "GA" cables are generally used for terminating. In Type "FA" cable all pairs, except a tracer pair, have the same colors of insulation. In Type "GA" cable each pair is distinguishable from every other by a color code. These two types of cable are made up of wires covered with two servings of silk and an outer serving of cotton.

Type "AUA" has conductors covered with two servings of cotton coated with cellulose acetate lacquer. This type of cable should be used where there would be objections to the usual method of waxing the exposed insulated conductors during installation. It replaces Type "UA" cable.

Types "MFA", "MGA", and "NUA" are similar to Types "FA", "GA", and "AUA", respectively, except that the conductors are enameled. The enameled cables are intended for the same kinds of service as the other three types, but are used where the humidity may be quite high for rather long periods, as, for example, near the sea coast in warm climates.

Cables with wool insulated conductors were once used for terminating, but it has been found that the cables described above are equally satisfactory for this purpose and are less expensive and easier to handle.

Special Cables

Special conditions often require cables with different characteristics from those which have been standardized and coded. Paper insulated cable, designed to withstand test potentials up to 1,500 volts a.c., is supplied for special circuits such as for telegraph or signal circuits. If your condition necessitates special cable, write our nearest distributor, giving full details and information, and price will be furnished.

Composite Cables

Composite cable, that is, composed of conductors of two or more gauges can be furnished if desired. The combinations of pairs which will utilize the space within the lead sheath most economically are somewhat limited and our cable engineers will make recommendations along this line upon receipt of detail information as to the conditions to be met.

Quadded Cable

Paper and textile insulated quadded lead covered cable for toll telephone and telegraph purposes can be furnished if desired. Price information will be quoted on your specifications if available or our cable engineers will make recommendations as to its use upon receipt of detailed information as to the conditions to be met. Consult our nearest distributor.

MANUFACTURING WESTERN ELECTRIC

PAPER INSULATED

LEAD COVERED CABLES

The first step in making the cable is insulating the copper wires with paper. Machines wrap the various colored papers used to identify the groups of pairs in the cable, around the conductors in the form of a helix with the edges overlapping.

Then the wires are twisted into pairs to hold them together and for the telephonic reason that proper twisting practically eliminates the possibility of cross-talk.

Next, the conductors are cabled in layers with a helical lay. This core is again wrapped with two or more wrappings of heavy paper as additional insulation from the sheath, and reeled to be dried. Before drying a test is made for "opens" and "crosses."

The core is now complete and tested. It is then dried in vacuum ovens, to expel all moisture from the core and passes through a lead press where the lead sheath is extruded around it. At this point, final testing takes place to search out "opens", "crosses," to determine electro-static capacity and conductivity standard, and to assure compliance with the specified breakdown fixed for that cable or type of cable.

Conductors

Conductors are of annealed copper of a high degree of purity. In size and number the pairs vary according to the purposes for which the cable is to be used. In the cables containing light gauge conductors extra pairs are provided. All of the extra pairs are rarely required to replace defective pairs. Therefore, some extras are available for additional circuits beyond the guaranteed number.

Around each conductor is wrapped a special quality of paper tape of suitable thickness to provide the insulation required by the purposes of the cable. This paper is manufactured especially for this purpose. It was selected after careful search for a paper having great toughness and a sufficiently high insulation resistance or dielectric strength to meet telephone cable manufacturing requirements.

Sheath

The sheath of Western Electric Telephone Cable for aerial or underground use is an alloy consisting of lead and antimony. Antimony was selected for the alloy as the result of many years' experience with cable sheath of different materials, while searching for a way to reduce the cost of lead covered cable without lowering its resistance to conditions of service. This alloy has been found to be considerably superior to pure lead sheath both for aerial use and for laying in underground conduits. Tests have also proven it to be equal for both purposes to the lead-tin alloy formerly used. If sheath composed of lead-tin alloy instead of lead-antimony is required it can be supplied.

Reels

Western Electric cables are shipped on substantial reels designed to withstand reasonable handling during the transportation and installation of the cables. The ends of the cables are fastened securely to the reels, an unarmored cable is protected by lags nailed around the periphery of the reel. The reels are made in a number of sizes, providing economical shipping packages for various sizes and lengths of cables.

LEAD COVERED CABLE—Continued

For Aerial or Underground Use

Type “NH” Cable

(Paper-Ribbon Insulated)

Replaces Type “TH”

Sheath. Lead Antimony.

Conductors. No. 16 A.W.G. single dry paper tape insulation. Blue orange pairs alternating with green orange pairs, except for 2 orange white tracer pairs, one in the center and one in the outside layer and a red orange pair in each layer containing an odd number of pairs.

Mutual Capacitance. A.C. testing .072 microfarad per mile of cable.

Conductor Resistance. Not exceeding 23 ohms per mile of cable, at 68 degrees Fahrenheit.

Insulation Resistance. Not less than 500 megohm miles.

Dielectric Strength. Insulation of each conductor capable of withstanding an a.c. test potential whose maximum instantaneous value is 1000 volts.

Attenuation. .75 decibels per mile at 1000 cycles. All pairs guaranteed good.

Code No. and Guaranteed Number of Pairs	Thickness Sheath Inches	Mean Outside Diameter Inches	Approximate Weight Pounds per Foot	Convenient Number of Feet on Reels
NH26	.080	1.13	1.79	1500
NH51	.090	1.52	2.94	1200
NH101	.105	2.12	5.13	800
NH152	.115	2.54	7.13	600

Type “AST” Cable

(Paper Pulp Insulated)

Replaces Type “ST”

Sheath. Lead Antimony.

Conductors. No. 26 A.W.G. pulp insulation, with color groups depending upon size.

Stranding. Multiple-unit design 152 pairs and larger.

Mutual Capacitance. A.C. testing .080 microfarad per mile of cable.

Conductor Resistance. Not exceeding 230 ohms per mile of cable at 68 degrees Fahrenheit.

Insulation Resistance. Not less than 500 megohm miles.

Dielectric Strength. Insulation of each conductor capable of withstanding an a.c. test potential whose maximum instantaneous value is 500 volts.

Attenuation. 2.7 decibels per mile at 1000 cycles.

Code No. and Number of Pairs	Number of Pairs Guaranteed	Thickness Sheath Inches	Mean Outside Diameter Inches	Approximate Weight Pounds per Foot	Stock Reel Length Feet
AST11	10	.070	.36	.34	3500
AST16	15	.070	.40	.40	3500
AST26	25	.070	.45	.46	3500
AST51	50	.070	.58	.64	3500
AST76	75	.070	.66	.78	3000
AST101	100	.070	.73	.91	3000
AST152	150	.075	.87	1.20	2000
AST202	200	.080	.97	1.47	2000
AST303	300	.080	1.16	1.89	1600
AST404	400	.085	1.33	2.36	1600
AST606	600	.095	1.60	3.30	1400
AST909	900	.105	1.90	4.56	1100
AST1212	1200	.105	2.15	5.51	900
AST1818	1800	.115	2.61	7.73	650

LEAD COVERED CABLE
For Aerial or Underground Use—Continued
Type “BPA” Cable
(Paper-Ribbon Insulated)

Replaces Type “APA”

Sheath. Lead Antimony.

Conductors. No. 22 A.W.G. double dry paper taped insulated, with color groups depending upon size.

Mutual Capacitance. A.C. testing .095 microfarad per mile of cable.

Conductor Resistance. Not exceeding 92 ohms per mile of cable at 68 degrees Fahrenheit.

Insulation Resistance. Not less than 500 megohm miles.

Dielectric Strength. Insulation of each conductor capable of withstanding a D.C. test potential of 500 volts.

Attenuation. 1.8 decibels per mile at 1000 cycles.

Code No. and Number of Pairs	Number of Pairs Guaranteed	Thickness Sheath Inches	Mean Outside Diameter Inches	Approximate Weight Pounds per Foot	Convenient Number of Feet on Reels
BPA6	5	.070	.39	.38	3500
BPA11	10	.070	.45	.47	3500
BPA16	15	.070	.52	.56	3500
BPA21	20	.070	.55	.62	3500
BPA26	25	.070	.58	.67	3500
BPA31	30	.070	.64	.77	3000
BPA41	40	.070	.70	.89	3000
BPA51	50	.075	.78	1.06	2500
BPA61	60	.075	.81	1.14	2500
BPA76	75	.075	.90	1.32	2500
BPA101	100	.080	1.00	1.62	2500
BPA152	150	.085	1.20	2.19	1600
BPA177	175	.085	1.26	2.39	1600
BPA202	200	.085	1.36	2.63	1600
BPA253	250	.090	1.49	3.16	1500
BPA303	300	.095	1.63	3.70	1400
BPA404	400	.105	1.87	4.78	1100
BPA606	600	.115	2.29	6.77	800

Type “CNB” Cable
(Paper-Ribbon Insulated)

Replaces Types “ANB” and “BNB”

Sheath. Lead Antimony.

Conductors. No. 19 A.W.G. single dry paper tape insulation, with color groups depending upon size.

Mutual Capacitance. A.C. testing .090 microfarad per mile of cable.

Conductor Resistance. Not exceeding 46 ohms per mile of cable, at 68 degrees Fahrenheit.

Insulation Resistance. Not less than 500 megohm miles.

Dielectric Strength. Insulation of each conductor capable of withstanding an a.c. test potential whose maximum instantaneous value is 700 volts.

Attenuation. 1.3 decibels per mile at 1000 cycles.

Code No. and Number of Pairs	Number of Pairs Guaranteed	Thickness Sheath Inches	Mean Outside Diameter Inches	Approximate Weight Pounds per Foot	Convenient Number of Feet on Reels
CNB6	5	.070	.44	.45	3500
CNB11	10	.070	.53	.60	3500
CNB16	15	.070	.61	.72	3500
CNB26	25	.070	.72	.93	3000
CNB51	50	.075	.95	1.46	2500
CNB76	75	.080	1.14	1.98	1800
CNB101	100	.085	1.30	2.48	1600
CNB152	150	.090	1.56	3.37	1400
CNB202	200	.095	1.78	4.25	1200
CNB303	300	.105	2.15	5.98	900
CNB404	400	.115	2.48	7.77	700
CNB455	450	.115	2.61	8.46	650

LEAD COVERED CABLE
For Aerial or Underground Use—Continued
Type “CSA” Cable
(Paper Pulp Insulated)

Replaces Types “ANA”, “ASA” and “BSA”

Sheath. Lead Antimony.

Conductors. No. 22 A.W.G. pulp insulation, with color groups depending upon size.

Stranding. Multiple-unit design 152 pairs and larger.

Mutual Capacitance. A.C. testing .090 microfarad per mile of cable.

Conductor Resistance. Not exceeding 92 ohms per mile of cable at 68 degrees Fahrenheit.

Insulation Resistance. Not less than 500 megohm miles.

Dielectric Strength. Insulation of each conductor capable of withstanding an a.c. test potential whose maximum instantaneous value is 500 volts.

Attenuation. 1.8 decibels per mile at 1000 cycles.

Code No. and Number of Pairs	Number of Pairs Guaranteed	Thickness Sheath Inches	Mean Outside Diameter Inches	Approximate Weight Pounds per Foot	Convenient Number of Feet on Reels
CSA11	10	.070	.44	.45	3500
CSA16	15	.070	.48	.52	3500
CSA26	25	.070	.58	.67	3500
CSA51	50	.070	.73	.95	3000
CSA76	75	.075	.87	1.27	2500
CSA101	100	.080	.99	1.58	2500
CSA152	150	.080	1.16	2.03	1600
CSA202	200	.085	1.33	2.55	1600
CSA303	300	.095	1.60	3.58	1400
CSA404	400	.095	1.78	4.28	1200
CSA606	600	.105	2.15	6.02	900
CSA909	900	.115	2.61	8.50	650

Type “CSM” Cable
(Paper Pulp Insulated)

Replaces Types “NM”, “SM” and “ASM”

Sheath. Lead Antimony.

Conductors. No. 24 A.W.G. pulp insulation, with color groups depending upon size.

Stranding. Multiple-unit design 152 pairs and larger.

Mutual Capacitance. A.C. testing .080 microfarad per mile of cable.

Conductor Resistance. Not exceeding 145 ohms per mile of cable, at 68 degrees Fahrenheit.

Insulation Resistance. Not less than 500 megohm miles.

Dielectric Strength. Insulation of each conductor capable of withstanding an a.c. test potential whose maximum instantaneous value is 500 volts.

Attenuation. 2.2 decibels per mile at 1000 cycles.

Code No. and Number of Pairs	Number of Pairs Guaranteed	Thickness Sheath Inches	Mean Outside Diameter Inches	Approximate Weight Pounds per Foot	Convenient Number of Feet on Reels
CSM11	10	.070	.39	.38	3500
CSM16	15	.070	.44	.45	3500
CSM26	25	.070	.52	.56	3500
CSM51	50	.070	.64	.77	3000
CSM76	75	.075	.76	1.02	2500
CSM101	100	.075	.85	1.20	2500
CSM152	150	.080	1.00	1.59	2500
CSM202	200	.080	1.14	1.91	1800
CSM303	300	.085	1.36	2.56	1600
CSM404	400	.090	1.56	3.22	1400
CSM606	600	.105	1.90	4.69	1100
CSM909	900	.115	2.29	6.51	900
CSM1212	1200	.115	2.61	7.97	650

LEAD COVERED CABLE—Continued
For Inside Construction

Type "FA" Cable
(Textile Insulated)

Replaces Type "F"

Sheath. Pure Lead.

Conductors. No. 22 A.W.G. tinned, double silk and single cotton insulation, covering on each pair colored white and red white.

Tracer Pair. One in outer layer colored blue and white.

Insulation Resistance. Not less than 500 megohm miles.

Conductor Resistance. Not exceeding 96 ohms per mile of cable, at 68 degrees Fahrenheit.

Dielectric Strength. Insulation of each conductor capable of withstanding an a.c. test potential whose maximum instantaneous value in 700 volts.

Code No. and Number of Pairs	Number of Pairs Guaranteed	Thickness Sheath Inches	Mean Outside Diameter Inches	Approximate Weight Pounds per Foot	Convenient Number of Feet on Reels
FA101	101	.063	1.00	1.42	2500
FA152	151	.063	1.19	1.86	1600
FA202	201	.094	1.41	2.93	1500
FA303	302	.125	1.75	4.68	1200
FA404	403	.125	1.97	5.62	1100
FA606	605	.125	2.38	7.45	700

Type "GA" Cable
(Textile Insulated)

Replaces Type "G"

Sheath. Pure Lead.

Conductors. No. 22 A.W.G. tinned, double silk and single cotton insulation, colored in accordance with a standard color scheme so that each pair is distinguishable from other pairs in the cable.

Conductor Resistance. Not exceeding 96 ohms per mile of cable at 68 degrees Fahrenheit.

Insulation Resistance. Not less than 500 megohm miles.

Dielectric Strength. Insulation of each conductor capable of withstanding an a.c. test potential whose maximum instantaneous value is 700 volts.

Code No. and Number of Pairs	Number of Pairs Guaranteed	Thickness Sheath Inches	Mean Outside Diameter Inches	Approximate Weight Pounds per Foot	Convenient Number of Feet on Reels
GA6	6	.047	.34	.25	3500
GA11	11	.047	.41	.32	3500
GA16	16	.047	.47	.39	3500
GA21	21	.047	.52	.45	3500
GA26	26	.047	.56	.51	3500
GA31	31	.047	.59	.56	3500
GA41	41	.047	.67	.67	3000
GA51	51	.063	.77	.94	2500
GA76	76	.063	.89	1.19	2500
GA101	101	.063	1.00	1.42	2500
GA152	151	.063	1.19	1.86	1600
GA202	201	.094	1.41	2.93	1500

LEAD COVERED CABLE
For Inside Construction—Continued

Type "AUA" Cable
(Textile Insulated)

Sheath. Pure Lead.

Conductors. No. 22 A.W.G. tinned, double cotton insulation, coated with cellulose acetate lacquer, colored in accordance with a standard color scheme so that each pair is distinguishable from other pairs in the cable.

Conductor Resistance. Not exceeding 96 ohms per mile of cable at 68 degrees Fahrenheit.

Insulation Resistance. Not less than 500 megohm miles.

Dielectric Strength. Insulation of each conductor capable of withstanding an a.c. test potential whose maximum instantaneous value is 700 volts.

Code No. and Guaranteed Number of Pairs	Thickness Sheath Inches	Mean Outside Diameter Inches	Approximate Weight Pounds per Foot	Convenient Number of Feet on Reels
AUA6	.047	.34	.25	3500
AUA11	.047	.41	.32	1000
AUA16	.047	.47	.39	1000
AUA21	.047	.52	.45	1000
AUA26	.047	.56	.51	1000
AUA31	.047	.59	.56	1000
AUA41	.047	.67	.67	3000
AUA51	.063	.77	.94	2500

Type "MFA" Cable
(Textile Insulated)

Replaces Type "LFA"

Sheath. Pure Lead.

Conductors. No. 22 A.W.G., tinned, enamel, double silk and single cotton insulation. Covering on each pair colored white and red-white.

Tracer Pair. One in outer layer colored blue and white.

Insulation Resistance. Not less than 500 megohm miles.

Conductor Resistance. Not exceeding 105 ohms per mile of cable, at 68 degrees Fahrenheit.

Dielectric Strength. Insulation of each conductor capable of withstanding an A.C. test potential whose maximum instantaneous value is 700 volts.

Code No. and No. of Pairs	Number of Pairs Guaranteed	Thickness Sheath Inches	Mean Outside Diameter Inches	Approximate Weight Pounds per Foot	Convenient Number of Feet on Reels
MFA101	101	.063	1.00	1.42	2500
MFA152	151	.063	1.19	1.86	1600
MFA202	201	.094	1.41	2.93	1500
MFA303	302	.125	1.75	4.68	1200
MFA404	403	.125	1.97	5.62	1100
MFA606	605	.125	2.38	7.45	700

LEAD COVERED CABLE
For Inside Construction—Continued

Type "MGA" Cable
(Textile Insulated)

Sheath. Pure Lead.

Conductors. No. 22 A.W.G., tinned, enamel, double silk and single cotton insulation, colored in accordance with a standard color scheme so that each pair is distinguishable from other pairs in the cable.

Conductor Resistance. Not exceeding 105 ohms per mile of cable, at 68 degrees Fahrenheit.

Insulation Resistance. Not less than 500 megohm miles.

Dielectric Strength. Insulation of each conductor capable of withstanding an A.C. test potential whose maximum instantaneous value is 700 volts.

Code No. and Number of Pairs	Number of Pairs Guaranteed	Thickness Sheath Inches	Mean Outside Diameter Inches	Approximate Weight Pounds per Foot	Convenient Number of Feet on Reels
MGA6	6	.047	.34	.25	3500
MGA11	11	.047	.41	.32	3500
MGA16	16	.047	.47	.39	3500
MGA21	21	.047	.52	.45	3500
MGA26	26	.047	.56	.51	3500
MGA31	31	.047	.59	.56	3500
MGA41	41	.047	.67	.67	3000
MGA51	51	.063	.77	.94	2500
MGA76	76	.063	.89	1.19	2500
MGA101	101	.063	1.00	1.42	2500
MGA152	151	.063	1.19	1.86	1600
MGA202	201	.094	1.41	2.93	1500

Type "NUA" Cable
(Textile Insulated)

Replaces Type "MUA"

Sheath. Pure Lead.

Conductors. No. 22 A.W.G. tinned, enamel, double cotton lacquered insulation, colored in accordance with standard color scheme so that each pair is distinguishable from other pairs in the cable.

Conductor Resistance. Not exceeding 105 ohms per mile of cable, at 68 degrees Fahrenheit.

Insulation Resistance. Not less than 500 megohm miles.

Dielectric Strength. Insulation of each conductor capable of withstanding an a.c. test potential whose maximum instantaneous value is 700 volts.

Code No. and Guaranteed Number of Pairs	Thickness Sheath Inches	Mean Outside Diameter Inches	Approximate Weight Pounds per Foot	Convenient Number of Feet on Reels
NUA6	.047	.34	.25	3500
NUA11	.047	.41	.32	1000
NUA16	.047	.47	.39	1000
NUA21	.047	.52	.45	1000
NUA26	.047	.56	.51	1000
NUA31	.047	.59	.56	1000
NUA41	.047	.67	.67	3000
NUA51	.063	.77	.94	2500

CABLE—SWITCHBOARD

The Western Electric switchboard cable having black enamel insulated conductors represents the highest developments in the art of switchboard cable manufacture. The cables listed below are made up of copper conductors which are tinned then black enamel insulated.

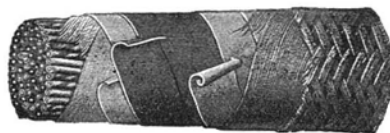

No. 6084

Switchboard cable (employing black enamel insulated conductors) is divided into two classes, depending upon the type of outer insulation.

1. The 1000, 1100 and 1200 coded series in which the conductors are provided with a double silk and single cotton insulation.
2. The 6000 coded series in which conductors are covered with two servings of cotton.

The cables are covered with a cotton braid and impregnated with a fireproofing paint.

In all types of switchboard cable, the outer insulation on each of the conductors is colored in accordance with a definite color scheme, so that they may be easily identified. For the purpose of reference, the various color combinations have been numbered as follows:

COLORS OF INSULATION ON CONDUCTORS

PAIRS			PAIRS		
Combination No.	Colors of Insulation:		Combination No.	Colors of Insulation:	
1	Blue	Paired with white	70	Blue-slate	Paired with red-white
2	Orange	Paired with white	71	Orange-white	Paired with red-white
3	Green	Paired with white	72	Orange-green	Paired with red-white
4	Brown	Paired with white	73	Orange-brown	Paired with red-white
5	Slate	Paired with white	74	Orange-slate	Paired with red-white
6	Blue-white	Paired with white	75	Green-white	Paired with red-white
7	Blue-orange	Paired with white	76	Green-brown	Paired with red-white
8	Blue-green	Paired with white	77	Green-slate	Paired with red-white
9	Blue-brown	Paired with white	78	Brown-white	Paired with red-white
10	Blue-slate	Paired with white	79	Brown-slate	Paired with red-white
11	Orange-white	Paired with white	80	Slate-white	Paired with red-white
12	Orange-green	Paired with white	81	Blue	Paired with black-white
13	Orange-brown	Paired with white	82	Orange	Paired with black-white
14	Orange-slate	Paired with white	83	Green	Paired with black-white
15	Green-white	Paired with white	84	Brown	Paired with black-white
16	Green-brown	Paired with white	85	Slate	Paired with black-white
17	Green-slate	Paired with white	86	Blue-white	Paired with black-white
18	Brown-white	Paired with white	87	Blue-orange	Paired with black-white
19	Brown-slate	Paired with white	88	Blue-green	Paired with black-white
20	Slate-white	Paired with white	89	Blue-brown	Paired with black-white
21	Blue	Paired with red	90	Blue-slate	Paired with black-white
22	Orange	Paired with red	91	Orange-white	Paired with black-white
23	Green	Paired with red	92	Orange-green	Paired with black-white
24	Brown	Paired with red	93	Orange-brown	Paired with black-white
25	Slate	Paired with red	94	Orange-slate	Paired with black-white
26	Blue-white	Paired with red	95	Green-white	Paired with black-white
27	Blue-orange	Paired with red	96	Green-brown	Paired with black-white
28	Blue-green	Paired with red	97	Green-slate	Paired with black-white
29	Blue-brown	Paired with red	98	Brown-white	Paired with black-white
30	Blue-slate	Paired with red	99	Brown-slate	Paired with black-white
31	Orange-white	Paired with red	100	Slate-white	Paired with black-white
32	Orange-green	Paired with red	101	Blue	Paired with red-black
33	Orange-brown	Paired with red	102	Orange	Paired with red-black
34	Orange-slate	Paired with red	103	Green	Paired with red-black
35	Green-white	Paired with red	104	Brown	Paired with red-black
36	Green-brown	Paired with red	105	Slate	Paired with red-black
37	Green-slate	Paired with red	106	Blue-white	Paired with red-black
38	Brown-white	Paired with red	107	Blue-orange	Paired with red-black
39	Brown-slate	Paired with red	108	Blue-green	Paired with red-black
40	Slate-white	Paired with red	109	Blue-brown	Paired with red-black
41	Blue	Paired with black	110	Blue-slate	Paired with red-black
42	Orange	Paired with black	111	Orange-white	Paired with red-black
43	Green	Paired with black	112	Orange-green	Paired with red-black
44	Brown	Paired with black	113	Orange-brown	Paired with red-black
45	Slate	Paired with black	114	Orange-slate	Paired with red-black
46	Blue-white	Paired with black	115	Green-white	Paired with red-black
47	Blue-orange	Paired with black	116	Green-brown	Paired with red-black
48	Blue-green	Paired with black	117	Green-slate	Paired with red-black
49	Blue-brown	Paired with black	118	Brown-white	Paired with red-black
50	Blue-slate	Paired with black	119	Brown-slate	Paired with red-black
51	Orange-white	Paired with black	120	Slate-white	Paired with red-black
52	Orange-green	Paired with black	121	Red-blue	Paired with white
53	Orange-brown	Paired with black	122	Red-orange	Paired with white
54	Orange-slate	Paired with black	123	Red-green	Paired with white
55	Green-white	Paired with black	124	Red-brown	Paired with white
56	Green-brown	Paired with black	125	Red-slate	Paired with white
57	Green-slate	Paired with black	126	Red-blue-white	Paired with white
58	Brown-white	Paired with black	127	Red-blue-orange	Paired with white
59	Brown-slate	Paired with black	128	Red-blue-green	Paired with white
60	Slate-white	Paired with black	129	Red-blue-brown	Paired with white
61	Blue	Paired with red-white	130	Red-blue-slate	Paired with white
62	Orange	Paired with red-white	131	Red-orange-white	Paired with white
63	Green	Paired with red-white	132	Red-orange-green	Paired with white
64	Brown	Paired with red-white	133	Red-orange-brown	Paired with white
65	Slate	Paired with red-white	134	Red-orange-slate	Paired with white
66	Blue-white	Paired with red-white	135	Red-green-white	Paired with white
67	Blue-orange	Paired with red-white	136	Red-green-brown	Paired with white
68	Blue-green	Paired with red-white	137	Red-green-slate	Paired with white
69	Blue-brown	Paired with red-white	138	Red-brown-white	Paired with white

CABLE—SWITCHBOARD—Continued

COLORS OF INSULATION ON CONDUCTORS—Continued

PAIRS			PAIRS		
Combination No.	Colors of Insulation:		Combination No.	Colors of Insulation:	
139	Red-brown-slate	Paired with white	160	Red-slate-white	Paired with red
140	Red-slate-white	Paired with white	161	Black-blue	Paired with red
141	Red-blue	Paired with red	162	Black-orange	Paired with red
142	Red-orange	Paired with red	163	Black-green	Paired with red
143	Red-green	Paired with red	164	Black-brown	Paired with red
144	Red-brown	Paired with red	165	Black-slate	Paired with red
145	Red-slate	Paired with red	166	Black-blue-white	Paired with red
146	Red-blue-white	Paired with red	167	Black-blue-orange	Paired with red
147	Red-blue-orange	Paired with red	168	Black-blue-green	Paired with red
148	Red-blue-green	Paired with red	169	Black-blue-brown	Paired with red
149	Red-blue-brown	Paired with red	170	Black-blue-slate	Paired with red
150	Red-blue-slate	Paired with red	171	Black-orange-white	Paired with red
151	Red-orange-white	Paired with red	172	Black-orange-green	Paired with red
152	Red-orange-green	Paired with red	173	Black-orange-brown	Paired with red
153	Red-orange-brown	Paired with red	174	Black-orange-slate	Paired with red
154	Red-orange-slate	Paired with red	175	Black-green-white	Paired with red
155	Red-green-white	Paired with red	176	Black-green-brown	Paired with red
156	Red-green-brown	Paired with red	177	Black-green-slate	Paired with red
157	Red-green-slate	Paired with red	178	Black-brown-white	Paired with red
158	Red-brown-white	Paired with red	179	Black-brown-slate	Paired with red
159	Red-brown-slate	Paired with red	180	Black-slate-white	Paired with red

SINGLES		SINGLES		SINGLES	
Combination No.	Colors of Insulation	Combination No.	Colors of Insulation	Combination No.	Colors of Insulation
1	Red-blue	21	Black-blue	41	Red-black-blue
2	Red-orange	22	Black-orange	42	Red-black-orange
3	Red-green	23	Black-green	43	Red-black-green
4	Red-brown	24	Black-brown	44	Red-black-brown
5	Red-slate	25	Black-slate	45	Red-black-slate
6	Red-blue-white	26	Black-blue-white	46	Red-black-blue-white
7	Red-blue-orange	27	Black-blue-orange	47	Red-black-blue-orange
8	Red-blue-green	28	Black-blue-green	48	Red-black-blue-green
9	Red-blue-brown	29	Black-blue-brown	49	Red-black-blue-brown
10	Red-blue-slate	30	Black-blue-slate	50	Red-black-blue-slate
11	Red-orange-white	31	Black-orange-white	51	Red-black-orange-white
12	Red-orange-green	32	Black-orange-green	52	Red-black-orange-green
13	Red-orange-brown	33	Black-orange-brown	53	Red-black-orange-brown
14	Red-orange-slate	34	Black-orange-slate	54	Red-black-orange-slate
15	Red-green-white	35	Black-green-white	55	Red-black-green-white
16	Red-green-brown	36	Black-green-brown	56	Red-black-green-brown
17	Red-green-slate	37	Black-green-slate	57	Red-black-green-slate
18	Red-brown-white	38	Black-brown-white	58	Red-black-brown-white
19	Red-brown-slate	39	Black-brown-slate	59	Red-black-brown-slate
20	Red-slate-white	40	Black-slate-white	60	Red-black-slate-white

SPARE PAIRS			SPARE SINGLES		
Combination No.	Colors of Insulation		Combination No.	Colors of Insulation	
1	White	Paired with red	1	Red-white	
2	White	Paired with black	2	Black-white	
3	Red	Paired with black	3	Red-black	
4	Red-white	Paired with white	4	Red-black-white	
5	Red-white	Paired with red			
6	Red-white	Paired with black			
7	Black-white	Paired with white			
8	Black-white	Paired with red			
9	Black-white	Paired with black			
10	Red-black	Paired with white			
11	Red-black	Paired with red			
12	Red-black	Paired with black			

GROUND WIRE			QUADS		
Combination No.	Color of Insulation		Combination No.	* Color of Insulation	
1	Black				

Combination No. (Quad No.)	Ring	First Pair Color of Insulation	Tip	Ring	Second Pair * Color of Insulation	Tip
1	Blue		Red-Blue	Novelty Black-Blue		Novelty Red-Blue
2	Orange		Red-Orange	Novelty Black-Orange		Novelty Red-Orange
3	Green		Red-Green	Novelty Black-Green		Novelty Red-Green
4	Brown		Red-Brown	Novelty Black-Brown		Novelty Red-Brown
5	Slate		Red-Slate	Novelty Black-Slate		Novelty Red-Slate
6	Blue-White		Red-Blue-White	Novelty Black-Blue-White		Novelty Red-Blue-White
7	Blue-Orange		Red-Blue-Orange	Novelty Black-Blue-Orange		Novelty Red-Blue-Orange
8	Blue-Green		Red-Blue-Green	Novelty Black-Blue-Green		Novelty Red-Blue-Green
9	Blue-Brown		Red-Blue-Brown	Novelty Black-Blue-Brown		Novelty Red-Blue-Brown
10	Blue-Slate		Red-Blue-Slate	Novelty Black-Blue-Slate		Novelty Red-Blue-Slate
11	Orange-White		Red-Orange-White	Novelty Black-Orange-White		Novelty Red-Orange-White
12	Orange-Green		Red-Orange-Green	Novelty Black-Orange-Green		Novelty Red-Orange-Green
13	Orange-Brown		Red-Orange-Brown	Novelty Black-Orange-Brown		Novelty Red-Orange-Brown

(Continued on page 25)

* Color listed as "Novelty Black" or "Novelty Red" consists of one ply of black or red yarn, respectively, twisted together with one ply of white yarn to form a single thread.

CABLE—SWITCHBOARD—Continued

Combination No. (Quad No.)	QUADS					
	First Pair			Second Pair		
	Color of Insulation	Ring	Tip	* Color of Insulation	Ring	Tip
14	Orange-Slate	Orange-Slate	Red-Orange-Slate	Novelty Black-Orange-Slate	Novelty Black-Orange-Slate	Novelty Red-Orange-Slate
15	Green-White	Green-White	Red-Green-White	Novelty Black-Green-White	Novelty Black-Green-White	Novelty Red-Green-White
16	Green-Brown	Green-Brown	Red-Green-Brown	Novelty Black-Green-Brown	Novelty Black-Green-Brown	Novelty Red-Green-Brown
17	Green-Slate	Green-Slate	Red-Green-Slate	Novelty Black-Green-Slate	Novelty Black-Green-Slate	Novelty Red-Green-Slate
18	Brown-White	Brown-White	Red-Brown-White	Novelty Black-Brown-White	Novelty Black-Brown-White	Novelty Red-Brown-White
19	Brown-Slate	Brown-Slate	Red-Brown-Slate	Novelty Black-Brown-Slate	Novelty Black-Brown-Slate	Novelty Red-Brown-Slate
20	Slate-White	Slate-White	Red-Slate-White	Novelty Black-Slate-White	Novelty Black-Slate-White	Novelty Red-Slate-White
Spare White	White	White	Red	Black	Black	Red-Black

*Color listed as "Novelty Black" or "Novelty Red" consists of one ply of black or red yarn, respectively, twisted together with one ply of white yarn to form a single thread.

DRY CORE—LEAD TAPED—BRAIDED—BLACK ENAMELED CONDUCTORS

Code No.	Conductors	Double Silk and Single Cotton Insulation Pairs			Singles			Dimensions (Inches)
		No.	Gauge	†Color	No.	Gauge	†Color	
1016	63	20	22	1-20	20	22	1-20	$\frac{23}{32} \times \frac{7}{16}$
1024	43	20	22	1-20	—	—	—	$\frac{5}{8} \times \frac{23}{64}$
1035	53	{ 20 5	{ 22 22	{ 1-20 121-125	—	—	—	$\frac{3}{4} \times \frac{13}{32}$
1050	33	10	22	1-10	10	22	1-10	$\frac{35}{64} \times \frac{23}{64}$
1060	75	{ 18 18	{ 22 22	{ 1-18 21-38	—	—	—	$\frac{13}{16} \times \frac{15}{32}$
1062	63	{ 15 15	{ 22 22	{ 1-15 21-35	—	—	—	$\frac{21}{32} \times \frac{31}{64}$
1066	103	{ 40 5 5	{ 22 22 22	{ 1-40 122-125 141-145	—	—	—	$\frac{3}{4}$ dia.
1069	205	100	22	1-100	—	—	—	$1\frac{1}{8}$ dia.
1070	83	{ 20 20	{ 22 22	{ 1-20 141-160	—	—	—	$\frac{27}{32} \times \frac{15}{32}$
1074	21	—	—	—	20	22	1-20	$\frac{3}{8}$ dia.
1079	23	10	22	1-10	—	—	—	$\frac{1}{2} \times \frac{5}{16}$
1084	63	20	22	1-20	20	22	1-20	$\frac{11\frac{1}{2}}{32} \times \frac{23}{64}$
1087	35	16	22	1-16	—	—	—	$\frac{21}{32} \times \frac{11}{32}$
1097	132	64	22	1-64	—	—	—	$1\frac{1}{8} \times \frac{5}{8}$
1100	83	{ 20 20	{ 24 24	{ 1-20 141-160	—	—	—	$\frac{21}{32} \times \frac{35}{64}$
1103	42	20	24	1-20	—	—	—	$\frac{9}{16} \times \frac{3}{8}$
1106	103	{ 20 20	{ 22 22	{ 1-20 141-160	20	22	21-40	$1 \times \frac{9}{16}$
1107	104	{ 20 19	{ 22 22	{ 1-20 141-159	{ 19 4	{ 22 16	{ 21-39 21-24	$1\frac{1}{2} \times \frac{9}{16}$
1115	64	20	19	1-20	20	22	1-20	$\frac{15}{16} \times \frac{7}{16}$
1116	43	20	19	1-20	—	—	—	$\frac{3}{4} \times \frac{23}{64}$
1117	83	{ 20 20	{ 22 19	{ 1-20 141-160	—	—	—	$\frac{31}{32} \times \frac{1}{2}$
1119	103	{ 20 5 5	{ 19 19 19	{ 21-40 121-125 141-145	—	—	—	$\frac{5}{64} \times \frac{5}{8}$
1121	53	{ 10 10	{ 19 22	{ 1-10 21-30	10	22	1-10	$\frac{3}{4} \times \frac{7}{16}$
1125	23	10	19	1-10	—	—	—	$\frac{9}{16} \times \frac{11}{32}$
1126	43	{ 10 10	{ 19 22	{ 1-10 11-20	—	—	—	$\frac{45}{64} \times \frac{13}{32}$
1127	33	10	19	1-10	10	22	1-10	$\frac{5}{8} \times \frac{3}{8}$
(k) 1182	13	6	22	(c)	—	—	—	$\frac{7}{16} \times \frac{9}{32}$
1183	53	{ 10 10	{ 22 22	{ 1-10 141-150	10	22	21-30	$\frac{3}{4} \times \frac{13}{32}$

† The numbers listed refer to the color combinations shown under the heading "Colors of Insulation on Conductors" page 23.

(c) Blue, orange, green, brown, slate and blue-white paired with singles, colors No. 41-46.

(k) Replaces No. 1081.

Note: Quantity shown under heading "Conductors" includes spares.

CABLE—SWITCHBOARD—Continued

Code No.	Conductors	Pairs			Singles			Dimensions (Inches)
		No.	Gauge	†Color	No.	Gauge	†Color	
1186	6	3	16	1-3	—	—	—	$1\frac{3}{32} \times 1\frac{19}{64}$
1187	12	6	16	1-6	—	—	—	$\frac{9}{16} \times 1\frac{11}{32}$
1188	16	8	16	1-8	—	—	—	$2\frac{1}{32} \times 2\frac{25}{64}$
1189	105	{ 20 20	{ 19 22	{ 1-20 21-40	20	22	1-20	1 x $\frac{9}{16}$
1200	12	6	19	1-6	—	—	—	$2\frac{3}{64} \times \frac{9}{32}$
1216	20	10	16	1-10	—	—	—	$2\frac{5}{32} \times \frac{7}{16}$
1232	83	{ 20 20	{ 22 22	{ 1-20 141-160	—	—	—	$1\frac{19}{32} \times 1\frac{13}{32}$
1236	63	20	24	1-20	20	24	1-20	$\frac{3}{4} \times \frac{3}{8}$
(f) 1237	(d) 312	20	22	(e)	20	22	1-20	1 $\frac{1}{16}$ dia.
		20	22	(e)	20	22	1-20	
		20	22	(e)	20	22	1-20	
		20	22	(e)	20	22	1-20	
		20	22	(e)	20	22	1-20	

† The numbers listed refer to the color combinations shown under the heading "Colors of Insulation of Conductors" page 23.

(d) One pair and one single may be defective.

(e) Nos. 1, 22, 3, 24, 5, 26, 7, 28, 9, 30, 11, 32, 13, 34, 15, 36, 17, 38, 19 and 40.

(f) Each group has a distinctive colored binder serving, brown, slate, blue, green and orange.

Note: Quantity shown under heading "Conductors" includes spares.

DRY CORE—LEAD TAPED—BRAIDED—BLACK ENAMELED CONDUCTORS

Code No.	Conductors	Pairs			Singles			Dimensions (Inches)
		No.	Gauge	†Color	No.	Gauge	†Color	
6016	63	20	22	1-20	20	22	1-20	$4\frac{9}{64} \times 2\frac{25}{64}$
6024	43	20	22	1-20	—	—	—	$3\frac{7}{64} \times 2\frac{23}{64}$
6035	53	{ 20 5	{ 22 22	{ 1-20 121-125	—	—	—	$\frac{5}{8} \times 1\frac{13}{32}$
6050	33	10	22	1-10	10	22	1-10	$3\frac{3}{64} \times 2\frac{1}{64}$
6060	75	{ 18 18	{ 22 22	{ 1-18 21-38	—	—	—	$2\frac{3}{32} \times 1\frac{15}{32}$
6062	63	{ 15 15 40	{ 22 22 22	{ 1-15 21-35 1-40	—	—	—	$4\frac{3}{64} \times \frac{7}{16}$
*6066	103	{ 5 5	{ 22 22	{ 121-125 141-145	—	—	—	$\frac{3}{4}$ dia.
*6069	205	100	22	1-100	—	—	—	1 $\frac{1}{8}$ dia.
6070	83	{ 20 20	{ 22 22	{ 1-20 141-160	—	—	—	$4\frac{9}{64} \times 1\frac{15}{32}$
*6074	21	—	—	—	20	22	1-20	$2\frac{3}{64}$ dia.
6079	23	10	22	1-10	—	—	—	$2\frac{9}{64} \times 1\frac{19}{64}$
6084	63	20	22	1-20	20	22	1-20	$1\frac{11}{32} \times 2\frac{23}{64}$
6087	35	16	22	1-16	—	—	—	$\frac{9}{16} \times 1\frac{11}{32}$
6097	132	64	22	1-64	—	—	—	$\frac{7}{8} \times \frac{5}{8}$
6100	83	{ 20 20	{ 24 24	{ 1-20 141-160	—	—	—	$1\frac{1}{16} \times 1\frac{15}{32}$
6102	103	{ 20 20	{ 24 24	{ 1-20 141-160	20	24	21-40	$4\frac{9}{64} \times 3\frac{1}{64}$
6103	42	20	24	1-20	—	—	—	$3\frac{5}{64} \times 2\frac{23}{64}$
6106	103	{ 20 20	{ 22 22	{ 1-20 141-160	20	22	21-40	$2\frac{5}{32} \times 3\frac{5}{64}$
6107	104	{ 20 19	{ 22 22	{ 1-20 141-159	{ 19 4	{ 22 16	{ 21-39 21-24	$1\frac{1}{32} \times \frac{9}{16}$
6115	64	20	19	1-20	20	22	1-20	$1\frac{15}{16} \times 1\frac{13}{32}$
6116	43	20	19	1-20	—	—	—	$2\frac{5}{32} \times 1\frac{13}{32}$
6117	83	{ 20 20 20	{ 19 22 19	{ 1-20 141-160 1-20	—	—	—	$1\frac{5}{16} \times \frac{7}{16}$
6119	103	{ 20 5 5	{ 19 19 19	{ 21-40 121-125 141-145	—	—	—	$1\frac{15}{16} \times 4\frac{5}{64}$

* Round shaped cables. All other cables are oval shaped.

† The numbers listed refer to the color combinations shown under the heading "Colors of Insulation of Conductors" page 23.

Note: Quantity shown under heading "Conductors" includes spares.

(Continued on page 27)

CABLE—SWITCHBOARD

DRY CORE—LEAD TAPED—BRAIDED—BLACK ENAMELED CONDUCTORS

Double Cotton Insulation (Continued)

Code No.	Conductors	Pairs			Singles			Dimensions (Inches)
		No.	Gauge	†Color	No.	Gauge	†Color	
6121	53	{10 10	19 22	{1-10 21-30	10	22	1-10	1 1/16 x 29/64
6125	23	{10 10	19 19	{1-10 1-10	—	—	—	3/16 x 1 1/32
6126	43	{10 10	19 22	{1-10 11-20	—	—	—	2 1/32 x 13/32
6127	33	{10 10	19 19	{1-10 1-10	10	22	1-10	37/64 x 3/8
6182	13	{6 6	22 22	{(D) (D)	—	—	—	3/8 x 1/4
6183	53	{10 10 10	22 22 19	{1-10 141-150 1-10	10	22	21-30	5/8 x 13/32
6184	63	{10 10 10	22 22 22	{51-60 141-150 1-10	—	—	—	27/32 x 1/2
6189	105	{20 20 20	19 22 22	{1-20 21-40 1-20	20	22	1-20	7/8 x 37/64
6191	93	{20 10	22 22	{1-20 121-130	30	22	21-50	23/32 x 33/64
6193	48	{15 15	22 22	{1-15 1-15	15	22	21-35	25/32 x 3/8
6196	43	{20 20	22 22	{(e) (e)	—	—	—	39/64 x 23/64
6198	42	{13 8	22 19	{(g) (h)	—	—	—	39/64 x 13/32
6199	50	{17 8	22 19	{(j) (h)	—	—	—	3/4 x 13/32
6201	63	{20 20	22 22	{(k) (k)	20	22	1-20	2 1/32 x 7/16
(y)6205	39	{12 12	22 22	{1-12 1-12	12	22	21-32	35/64 x 23/64
6215	32	{4 4	19 19	{1-4 1-4	20	16	1-20	3/4 x 13/32
6217	46	{5 5	19 19	{(t) (t)	{17 17	22 22	{1-17 21-37	5/8 x 3/8
6218	39	{5 5	19 19	{(t) (t)	{14 13	22 22	{1-14 21-33	37/64 x 1 1/32
6221	62	{15 15 10	19 19 24	{1-15 21-35 121-130	—	—	—	25/32 x 1 1/32
6222	103	{10 10 10	24 24 24	{151-160 41-50 71-80	20	24	41-60	49/64 x 1/2
6227	83	{20 20	24 24	{1-20 141-160	—	—	—	1 13/64 x 3/8
6233	123	{40 40	22 22	{1-40 1-40	40	22	1-40	7/8 x 39/64
6234	164	{40 40	22 22	{121-160 1-40	—	—	—	31/32 x 43/64
6235	205	{40 40	22 22	{1-40 121-160	40	22	1-40	57/64 dia.
(u) 6236	63	{20 20 20	24 22 22	{1-20 (v) (v)	20	24	1-20	3/4 x 3/8
(w)6237(x)312		{20 20 20 20	22 22 22 22	{(v) (v) (v) (v)	{20 20 20 20	22 22 22 22	{1-20 1-20 1-20 1-20	1 1/16 dia.

† The numbers listed refer to the color combinations shown under the heading "Colors of Insulation on Conductors" page 23.

(d) Blue, orange, green, brown, slate and blue-white paired with singles, colors No. 41-46.

(e) Nos. 1, 3, 5, 7, 9, 11, 13, 15, 17, 19, 141, 143, 145, 147, 149, 151, 153, 155, 157 and 159.

(g) Nos. 1 to 13 singles twisted with Nos. 21 to 33 singles respectively.

(h) Nos. 41 to 48 singles twisted with Nos. 51 to 58 singles respectively.

(j) Nos. 1 to 17 singles twisted with Nos. 21 to 37 singles respectively.

(k) Nos. 1, 22, 3, 24, 5, 26, 7, 28, 9, 30, 11, 32, 13, 34, 15, 36, 17, 38, 19, 40.

(t) Nos. 41 to 45 singles twisted with Nos. 51 to 55 singles respectively.

(u) Partially replaces No. 6120.

(v) Nos. 1, 22, 3, 24, 5, 26, 7, 28, 9, 30, 11, 32, 13, 34, 15, 36, 17, 38, 19 and 40.

(w) May be used in place of 5 No. 6201 cables. Each group has a distinctive colored binder serving, brown, slate, blue, green and orange.

(x) One pair and one single may be defective.

(y) Replaces No. 6204.

Note: Quantity shown under heading "Conductors" includes spares.

CABLE—SWITCHBOARD—Continued

Double Silk and Single Cotton Insulation

Code No.	Conductors	Pairs			Singles			Dimensions (Inches)
		No.	Gauge	†Color	No.	Gauge	†Color	
16C	63	20	22	1-20	20	22	1-20	$2\frac{5}{32} \times 7\frac{1}{16}$
70C	83	{20 20	{22 22	{1-20 141-160}	—	—	—	$4\frac{3}{64} \times 1\frac{15}{32}$
84C	63	20	22	1-20	20	22	1-20	$1\frac{11}{32} \times 1\frac{11}{32}$
230C	136	{60 6	{22 22	{1-60 (f)}	—	—	—	$5\frac{9}{64} \times 1\frac{19}{32}$
232C	83	{20 20	{22 22	{1-20 141-160}	—	—	—	$1\frac{19}{32} \times 3\frac{3}{8}$
236C	63	20	24	1-20	20	24	1-20	$\frac{3}{4} \times 3\frac{3}{8}$
238C	103	{10 10 20	{24 24 24	{121-130 151-160 51-70}	20	24	41-60	$6\frac{1}{64} \times 7\frac{1}{16}$
239C	103	{20 20	{22 22	{1-20 161-180}	20	22	1-20	$1\frac{19}{32} \times 3\frac{3}{8}$
(b)243C	312	100	22	1-20	100	22	1-20	—

† The numbers listed refer to the color combinations shown under the heading "Colors of Insulation on Conductors" page 23.

(b) Made up of 5 units, each unit containing 20 pairs and 20 singles. Each unit has a distinctive colored binder serving, brown, slate, blue, green and orange. Spare conductors are in the center of the cable.

(f) Black-white paired with white, black-white paired with red, black-white paired with black, black-orange paired with white, black-orange paired with red, black-orange paired with black.

WAXED CORE—NOT LEAD TAPED—BLACK ENAMELED CONDUCTORS

The following cables have tinned black enameled, single silk served and cotton braided conductors and wax cores. The cores are covered with a cotton braid which is impregnated with fireproofing paint.

Code No.	Conductors	Pairs			Diameter (Inches)
		No.	Gauge	†Color	
1450	6	3	20	(c)	$1\frac{9}{64}$
1451	12	6	20	(d)	$2\frac{5}{64}$
1452	16	8	20	(e)	$2\frac{9}{64}$
1453	22	11	20	(f)	$3\frac{1}{64}$
1454	20	10	16	1-10	$\frac{1}{2}$
1455	3	—	20	(g)	$1\frac{3}{64}$

† The numbers listed refer to the color combinations shown under the heading "Colors of Insulation on Conductors" page 23.

(c) Black paired with black-red; red with red-green; yellow with yellow-green.

(d) Same as first six pairs given under footnote (f).

(e) Same as first eight pairs given under footnote (f).

(f) Black paired with black-red

Red paired with red-green

Yellow paired with yellow-green

Brown paired with brown-red

Slate paired with slate-red

Black paired with red

Yellow paired with red

Brown paired with red

Slate paired with red

Black-red paired with red-green

Yellow-green paired with brown-red

(g) Yellow, yellow-green, red-green.

Note: Quantity shown under heading "Conductors" includes spares.

CABLE—SWITCHBOARD—Continued

Inter-phone Cable

The conductors are provided with single silk and single cotton insulation which is colored in such a way that each pair and each single wire can be identified. The cable is then impregnated with a wax compound and is covered with servings of paper and a heavy braiding, which is given a heavy coat of fireproofing paint.

Lead covered cables are not listed with separate code numbers. Any fireproofed type of cable may be ordered with a lead sheath.

Code No.	Con-ductors	Pairs			Singles			Covering	Approx. Diam. (Inches)
		No.	Gauge	†Color	No.	Gauge	†Color		
185B	4				4	22	1-4	Fireproofed Braid	.25
161B	8				7	22	1-7	Fireproofed Braid	.28
161B	8				7	22	1-7	Lead Sheath	.37
142B	8				8	22	1-8	Brown Cotton Braid	.32
162B	12				11	22	1-11	Fireproofed Braid	.32
162B	12				11	22	1-11	Lead Sheath	.41
164B	12	2	18	121-122	6	22	1-6	Fireproofed Braid	.35
134B	18	{ 6 2	{ 22 18	{ 1-6 121-122				Fireproofed Braid	.41
134B	18	{ 6 2	{ 22 18	{ 1-6 121-122				Lead Sheath	.50
155B	18	{ 6 2	{ 22 18	{ 1-6 121-122				Brown Cotton Braid	.40
141B	30	{ 12 2	{ 22 18	{ 1-12 121-122				Fireproofed Braid	.41
141B	30	{ 12 2	{ 22 18	{ 1-12 121-122				Lead Sheath	.50
156B	30	{ 12 2	{ 22 18	{ 1-12 121-122				Brown Cotton Braid	.43
157B	38	{ 16 2	{ 22 18	{ 1-16 121-122				Fireproofed Braid	.50
157B	38	{ 16 2	{ 22 18	{ 1-16 121-122				Lead Sheath	.59
158B	46	{ 20 2	{ 22 18	{ 1-20 121-122				Fireproofed Braid	.56
158B	46	{ 20 2	{ 22 18	{ 1-20 121-122				Lead Sheath	.65
136B	54	{ 24 2	{ 22 18	{ 1-24 121-122				Fireproofed Braid	.59
136B	54	{ 24 2	{ 22 18	{ 1-24 121-122				Lead Sheath	.68
140B	68	{ 31 2	{ 22 18	{ 1-31 121-122				Fireproofed Braid	.62
140B	68	{ 31 2	{ 22 18	{ 1-31 121-122				Lead Sheath	.71

Note: Quantity shown under heading "Conductors" includes spares.

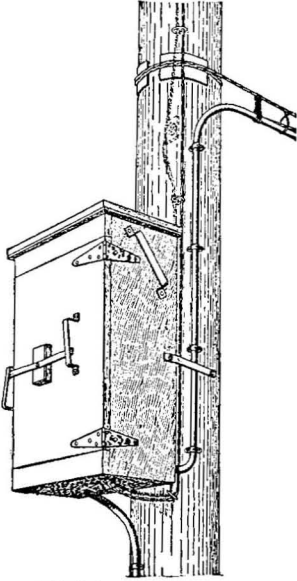
CABLE TERMINALS**General****"B" Type Cable Terminal**

Cable terminals used out-of-doors should include a means of effectively sealing the cable end in such a manner as to prevent the entrance of moisture into the cable core. Experience indicates that the most satisfactory results are obtained by the use of terminating chambers in which cable stubs are connected and sealed at the factory. It is then only necessary to splice the cable stub to the cable in the field and the usual rubber-covered wire pothead is avoided, thereby eliminating an expensive field operation. By this method, the connecting and potheading is accomplished in the factory with every facility for producing a perfect product and the best electrical and mechanical qualities are obtained.

Several styles of Western Electric cable terminals for out-door use may be obtained with cable stubs of No. 22 B. & S. gauge cable of suitable length, connected and potheaded in the terminals.

The selection of Cable Terminals for use at various points in the plant involves the provision of suitable protection against lightning and crosses with neighboring light and power circuits and also protection against the entrance of moisture into the cable core. Proper cross-connecting facilities should be provided where required and provision made for future changes and additions. The cable terminals, cable terminal boxes and accessory apparatus described in the succeeding pages offer these features in a number of combinations.

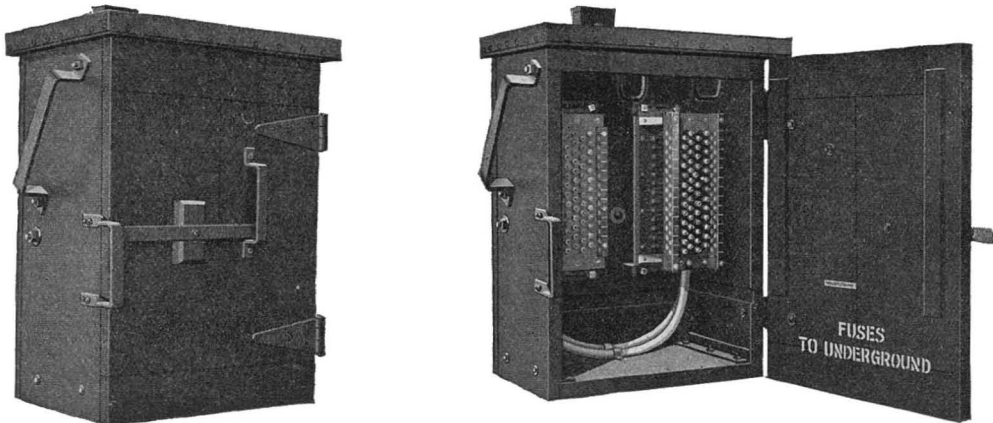
Type "B" Cable Terminals (Protected)**B26 Cable Terminal**

"B" Cable Terminals have been designed to supply a flexible form of terminal, adaptable for use at many points in a cable system, and having the highest electrical and mechanical qualities. Potheading in the field is eliminated through their use.

Each complete "B" Cable Terminal consists of a "B" Cable Terminal Box in which are assembled a cast iron "B" Fuse Chamber and a cast iron "B" Binding Post Chamber. These two items are fully described in connection with their separate listing. A cable stub is connected and potheaded in each chamber.

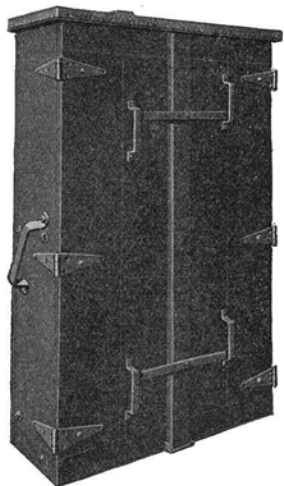
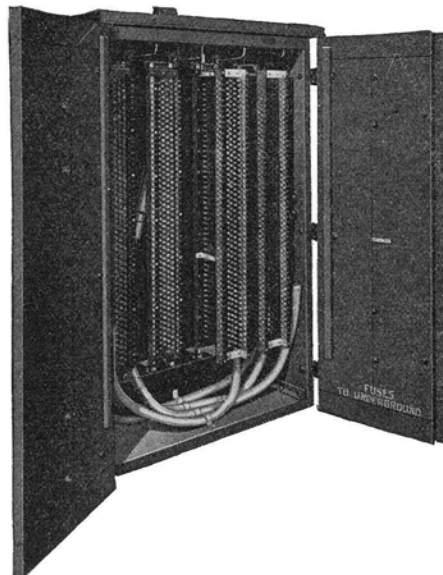
CABLE TERMINALS**Type "B" Cable Terminals (Protected)—Continued****B202 Cable Terminal. Closed View****B202 Cable Terminal. Open View**

The boxes are substantially constructed of wood with a sheet zinc covering on the top and are finished with green pole paint. The bottom of the box is removable. Suitable space is provided in the lower part of the boxes for the splicing of the terminating cables to the cable stubs which are attached to the sealed chambers. Holes in the bottom of the terminal box permit bridle wires or drops to be connected to the cable terminal and, where necessary, the No. 83A Protector Mounting may be mounted nearby to supply lightning protection for these lines.

1. At the junction of underground and aerial cable, at locations where fuse protection is required no potheading in the field is necessary with a complete "B" Cable Terminal. This terminal is designed for cross-connecting and provides fuse mountings.

2. Where underground and aerial cables are joined, at locations where fuse protection is required and open or drop wires are also connected to the cable lines, a "B" Cable Terminal may be used for cross-connecting the cables and No. 83A Protector Mountings placed on the pole to provide open space cut-outs for the separate lines.

3. When open or drop wires are connected to an underground cable, at locations where fuse protection is required a partially equipped "B" Cable Terminal Box having a fuse chamber may be used and open space cut-outs inserted in the lines by means of the No. 83A Protector Mounting placed on the pole.

4. Aerial cable may be joined to open or drop lines by means of a "B" Cable Terminal Box in which a "B" binding post chamber is used. Lightning protection may be provided, if needed, by the use of a No. 83A Protector Mounting mounted on the pole.

5. When it is desired to place a cross-connecting terminal at the point where aerial cable branches, or to cross-connect long sections of aerial cable, a "B" Cable Terminal Box may be used and equipped with two "B" Binding Post Chambers. This combination is a "BB" Binding Post Chamber described on page 32.

CABLE TERMINALS**Type "B" Cable Terminals (Protected)—Continued**

The listing of Type "B" Cable Terminals complete includes a terminal box, equipped with fuse chambers and binding post chambers, each of which is supplied with a cable stub attached and potheaded, but do not include the No. 7T Fuses, two of which are needed for each pair of wires and they should be ordered separately. Fuse chambers and binding post chambers may be ordered as separate items and are listed and described under their proper headings.

The B26 Cable Terminal will terminate both a 26 pair underground cable and a 26 pair aerial cable and provides for cross-connection. The other sizes have similar capacity ratings.

Pole seats may be used with the two smaller sizes of "B" Cable Terminals and these together with balconies for the large terminals can be obtained.

Code No.	Capacity Pairs	Cable Terminal Box No.	Includes	
			Equipped With	
B26	26	B26	1 B26A Fuse Chamber and 1 B26A Binding Post Chamber	
B51	51	B51	1 B51A Fuse Chamber and 1 B51A Binding Post Chamber	
B76	76	B76	1 B76A Fuse Chamber and 1 B76A Binding Post Chamber	
B101	101	B101	1 B101A Fuse Chamber and 1 B101A Binding Post Chamber	
B152	152	B152	2 B76B Fuse Chamber and 2 B76B Binding Post Chamber	
B202	202	B202	2 B101B Fuse Chamber and 2 B101B Binding Post Chamber	
B304	304	B304	2 B76B Fuse Chamber and 2 B76B Binding Post Chamber	
			2 B76C Fuse Chamber and 2 B76C Binding Post Chamber	
B404	404	B404	2 B101B Fuse Chamber and 2 B101B Binding Post Chamber	
			2 B101C Fuse Chamber and 2 B101C Binding Post Chamber	

Note. "B" Fuse Chambers do not include the No. 7T Fuses which must be ordered separately. See description of "B" Fuse Chambers.

Type "BB" Cable Terminals (Unprotected)

The Type "BB" Cable Terminal was designed for use in cross-connecting long sections of aerial cable and at points where aerial cables branch. It is also used for cross-connection between aerial and underground cable at locations where fuse protection is not required. They consist of a Cable Terminal Box and Binding Post Chambers and are arranged with a splicing chamber at the bottom of the box for splices.

Code No.	Capacity (Pairs)	Cable Terminal Box No.	Includes	
			Equipped With	
BB26	26	BB26	1 B26A and 1 BB26A Binding Post Chambers	
BB51	51	BB51	1 B51A and 1 BB51A Binding Post Chambers	
BB76	76	BB76	1 B76A and 1 BB76A Binding Post Chambers	
BB101	101	BB101	1 B101A and 1 BB101A Binding Post Chambers	
BB152	152	BB152	2 B76B and 2 BB76B Binding Post Chambers	
BB202	202	BB202	2 B101B and 2 BB101B Binding Post Chambers	
BB304	304	BB304	2 B76B and 2 BB76B Binding Post Chambers	
			2 B76C and 2 BB76C Binding Post Chambers	
BB404	404	BB404	2 B101B and 2 BB101B Binding Post Chambers	
			2 B101C and 2 BB101C Binding Post Chambers	

CABLE TERMINALS—Continued

Type “F” Cable Terminals (Unprotected)

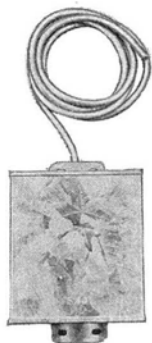

“F” Type Cable Terminal



“F” Type Cable Terminal (Open)

This type Cable Terminal is intended for terminating lead covered cable in outdoor distribution systems and consists of a galvanized sealing chamber equipped with terminals with cable stub and a slip cover.

It is equipped with a detachable mounting plate and is reversible so that it can be readily changed when a bottom stubbed terminal is desired.

The F-10, F-16 and F-26 Cable Terminals are 10, 16, and 26 pair terminals, respectively. The standard lengths of the cable stubs for each of the three sizes are 5' 6", 8' 0", 10' 0" and 12' 0". The desired lengths are to be specified in the order.

Entirely replaces the “C” type and 14 type Cable Terminals in corresponding sizes. The F-10 and F-16 Cable Terminals also replace the D-94850 and D-94851 Cable Terminals, respectively.

The overall dimensions of these Cable Terminals, not including the cable stubs are as follows:

Cable Terminal	Height	Overall Dimensions (Inches)	
		Width	Depth
F-10	8½	7½	4⅝
F-16	10⅝	7½	4⅝
F-26	15½	7½	4⅝

Type “EA” Cable Terminals

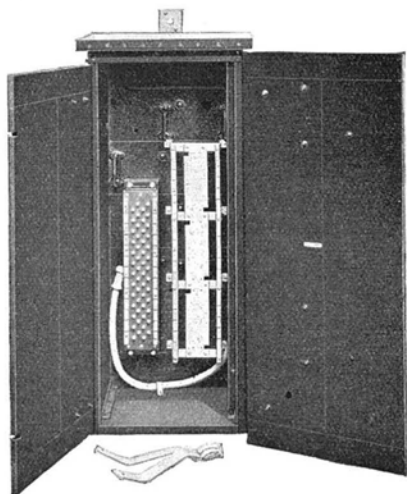

(Open)

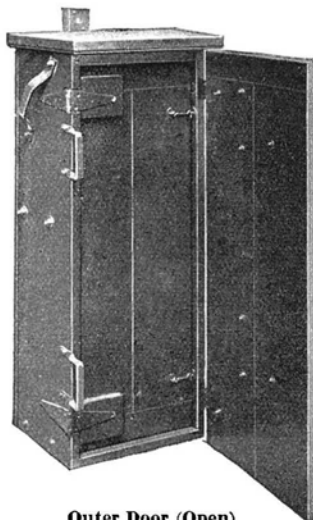

Outer Door (Open)

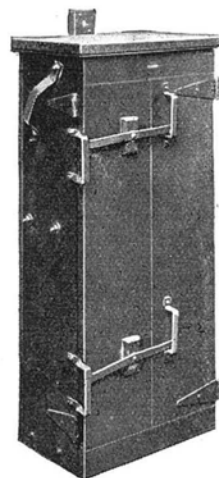

(Closed)

No. EA-26 Cable Terminal

The EA Type Cable Terminal is intended for use on toll lines at the junction of aerial or underground cables and open wire lines.

The EA-26 and EA-51 Cable Terminals provide open space cut-out protection for 26 pairs and 51 pairs of wires, respectively. Consists of an assembly of apparatus as follows:

Type	Capacity Pairs	Includes	Overall Dimensions (Inches)		
			Height	Width	Depth
EA-26	26	1 E-26 Cable Terminal Box 1 E-26 Binding Post Chamber 1 87-A Protector Mounting	50½	20⅝	17⅞
EA-51	51	1 E-51 Cable Terminal Box 1 E-51 Binding Post Chamber 2 87-A Protector Mountings	55½	34⅜	15⅝

Note. 84A protector mounting and 30 and 36 protector blocks are required for use in the EA Type Cable Terminals but must be ordered separately.

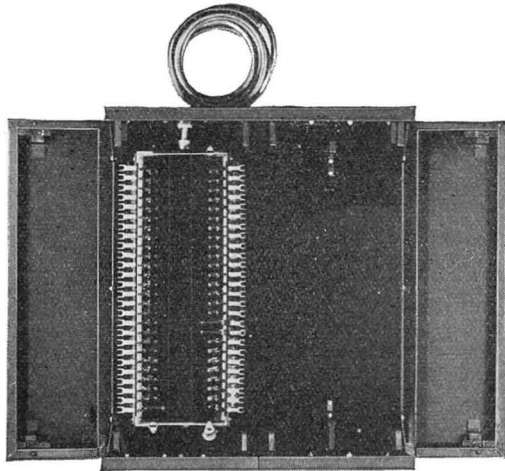
CABLE TERMINALS—Continued**TYPE "LA" CABLE TERMINALS (PROTECTED)**

No. LA-26 Cable Terminal
Open

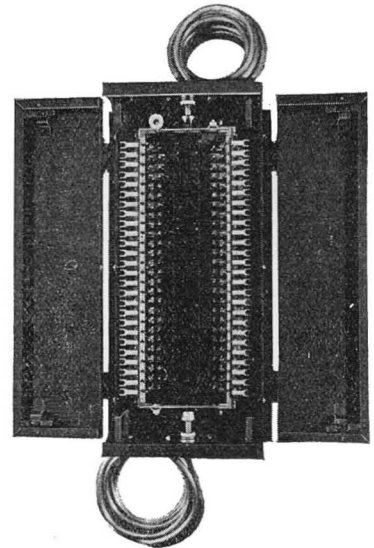

No. LB-26 Cable Terminal
Open

Protected Cable Terminals intended to provide a moisture-proof seal for lead covered cables terminating in buildings. Arranged for cross-connections in terminal.

"LA" Type Cable Terminals consist of an assembly of apparatus as follows:

Type	Capacity Pairs	Includes	Overall Dimensions (Inches)		
			Height	Width	Depth
LA-16	16	1 LA-16 Fuse Chamber 1 No. 83A Backboard 2 M16 Cable Terminal Sections 2 L16 Cable Terminal Sections	21 ³ / ₄	26 ¹ / ₄	8 ³ / ₁₆
LA-26	26	1 LA-26 Fuse Chamber 1 No. 83-B Backboard 2 M26 Cable Terminal Sections 2 L26 Cable Terminal Sections	29 ³ / ₈	26 ¹ / ₄	8 ³ / ₁₆
LA-51	51	1 LA-51 Fuse Chamber 1 No. 83-C Backboard 2 M51 Cable Terminal Sections 2 L-51 Cable Terminal Sections	48 ⁷ / ₈	26 ¹ / ₄	8 ³ / ₁₆

Type "LB" Cable Terminals (Protected)

Protected Cable Terminals intended to provide a moisture-proof seal for lead covered cables terminating in buildings. Not arranged for cross-connections in terminal.

"LB" Type Cable Terminals consist of an assembly of apparatus as follows:

Type	Capacity Pairs	Includes	Overall Dimensions (Inches)		
			Height	Width	Depth
LB-16	16	1 LB-16 Fuse Chamber 1 L-16 Cable Terminal Section 2 M-16 Cable Terminal Sections	21 ³ / ₄	14 ¹ / ₈	8 ³ / ₁₆
LB-26	26	1 LB-26 Fuse Chamber 1 L-26 Cable Terminal Section 2 M-26 Cable Terminal Sections	29 ³ / ₈	14 ¹ / ₈	8 ³ / ₁₆
LB-51	51	1 LB-51 Fuse Chamber 1 L-51 Cable Terminal Section 2 M-51 Cable Terminal Sections	48 ⁷ / ₈	14 ¹ / ₈	8 ³ / ₁₆

CABLE TERMINALS—Continued

No. 12 Type Cable Terminals (Unprotected)

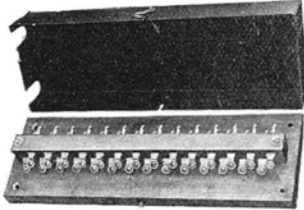

No. 12A Cable Terminal

The No. 12 Type Cable Terminal is for interior distribution, and consists of a wooden base and a black finished metal cover. They are equipped with terminals having soldering connections at one end and screw connections at the other. Cable forms may be brought in from either end

Code No.	Capacity Pairs	Overall Dimensions (Inches)
12A	13	11 ⁶ / ₁₆ x 4 ³ / ₁₆ x 1 ³ / ₁₆
12B	23	11 ⁶ / ₁₆ x 4 ³ / ₁₆ x 2 ³ / ₁₆
12C	33	11 ⁶ / ₁₆ x 4 ³ / ₁₆ x 3 ³ / ₁₆

No. 18 Type Cable Terminals (Protected)



No. 18E Cable Terminal, Open



No. 18E Cable Terminal, Closed

This is a protected terminal for open wire distribution from lead covered underground or aerial cable. The heavy base is slotted at the back, forming a bracket suitable for either pole or wall mounting and both the base and the metal hood are protected from corrosion by galvanizing. A spring device holds the cover when it is raised to the top of the terminal, a chain attached to the base prevents it being dropped or mislaid when removed.

Locknut spun wire binding posts for the line connections are mounted directly on the sides of the sealed chamber and extensions of the walls of the chamber provide fanning strips. This construction is compact and strong. Each cable terminal is provided with a heavy, binding post locknut for connecting the ground wire of the protectors.

The fuses and open space protectors provided are designed for protection against lightning and crosses with light and power circuits and represent the most modern design.

The fuses make contact with the terminals by means of a screw connection at one end and a locknut at the other. The line connections can be changed without removing the fuses.

The terminals, as furnished, are equipped with:

No. 7A Fuses (7 ampere, unless otherwise specified).

No. 1 Protector Blocks.

No. 2 Protector Blocks.

No. 3 Protector Mica.

A six-foot cable stub of No. 22 B. & S. gauge cable will be furnished properly connected and pot-headed within the terminal unless otherwise specified.

Code No.	Capacity (Pairs)	Length (Inches)	Diameter of Hood (Inches)
18A	10	19 ⁹ / ₃₂	8 ⁹ / ₁₆
18B	15	22 ¹ / ₃₂	8 ⁹ / ₁₆
18C	25	28 ²⁹ / ₃₂	8 ⁹ / ₁₆
18D	30	33 ¹ / ₃₂	8 ⁹ / ₁₆
18E	50	46 ²⁹ / ₃₂	8 ⁹ / ₁₆
18F	60	53 ²⁹ / ₃₂	8 ⁹ / ₁₆

CABLE TERMINALS—Continued**Type "B" Cable Terminal Boxes**

Code No.	Used with Type "B" Cable Terminals	Dimensions (Inches)		
		Height	Width	Depth
B26	B26	28 $\frac{1}{32}$	21 $\frac{3}{4}$	15 $\frac{5}{16}$
B51	B51	36 $\frac{31}{32}$	22 $\frac{3}{4}$	15 $\frac{5}{16}$
B76	B76	45 $\frac{7}{32}$	22 $\frac{3}{4}$	15 $\frac{5}{16}$
B101	B101	54 $\frac{13}{32}$	22 $\frac{3}{4}$	15 $\frac{5}{16}$
B152	B152	46 $\frac{7}{32}$	36 $\frac{3}{4}$	15 $\frac{5}{16}$
B202	B202	55 $\frac{7}{32}$	36 $\frac{3}{4}$	15 $\frac{5}{16}$
B304	B304	91 $\frac{1}{2}$	38 $\frac{1}{4}$	15 $\frac{5}{16}$
B404	B404	109 $\frac{1}{4}$	38 $\frac{1}{4}$	15 $\frac{5}{16}$

Type "BB" Cable Terminal Boxes

Code No.	Used with Type "BB" Cable Terminals	Approximate Dimensions (Inches)		
		Height	Width	Depth
BB26	BB26	28 $\frac{1}{32}$	21 $\frac{3}{4}$	15 $\frac{5}{16}$
BB51	BB51	36 $\frac{31}{32}$	22 $\frac{3}{4}$	15 $\frac{5}{16}$
BB76	BB76	45 $\frac{1}{32}$	22 $\frac{3}{4}$	15 $\frac{5}{16}$
BB101	BB101	54 $\frac{5}{32}$	22 $\frac{3}{4}$	15 $\frac{5}{16}$
BB152	BB152	46 $\frac{7}{32}$	36 $\frac{3}{4}$	15 $\frac{5}{16}$
BB202	BB202	55 $\frac{5}{32}$	36 $\frac{3}{4}$	15 $\frac{5}{16}$
BB304	BB304	91 $\frac{5}{16}$	38 $\frac{1}{4}$	15 $\frac{5}{16}$
BB404	BB404	109 $\frac{13}{16}$	38 $\frac{1}{4}$	15 $\frac{5}{16}$

Type E26 and E51 Cable Terminal Boxes

The E26 Cable Terminal Box consists of a wooden cable terminal box having a double door and arranged to mount one E26 binding post chamber and one No. 87A protector mounting. When equipped with an E26 binding post chamber and a No. 87A protector mounting it forms the EA26 cable terminal. Arranged for mounting on poles. Braces are provided for bracing the box to the pole and are arranged to be attached to the sides of the box by means of bolts and nuts which are furnished. The EA26 cable terminal is provided with distributing rings for holding cross connecting wires. Finished with green cable box paint unless otherwise specified.

The dimensions are the same as the EA26 Cable Terminal.

The E51 Cable Terminal Box is the same as the E26 Cable Terminal Box, except arranged to mount an E51 binding post chamber and two No. 87A protector mountings. It is provided with distributing rings for holding cross connecting wires. When so equipped it forms the EA51 cable terminal.

The dimensions are the same as the EA51 Cable Terminal.

CABLE TERMINALS—Continued

Type “GA”, “GB” and “GC” Cable Terminal Boxes

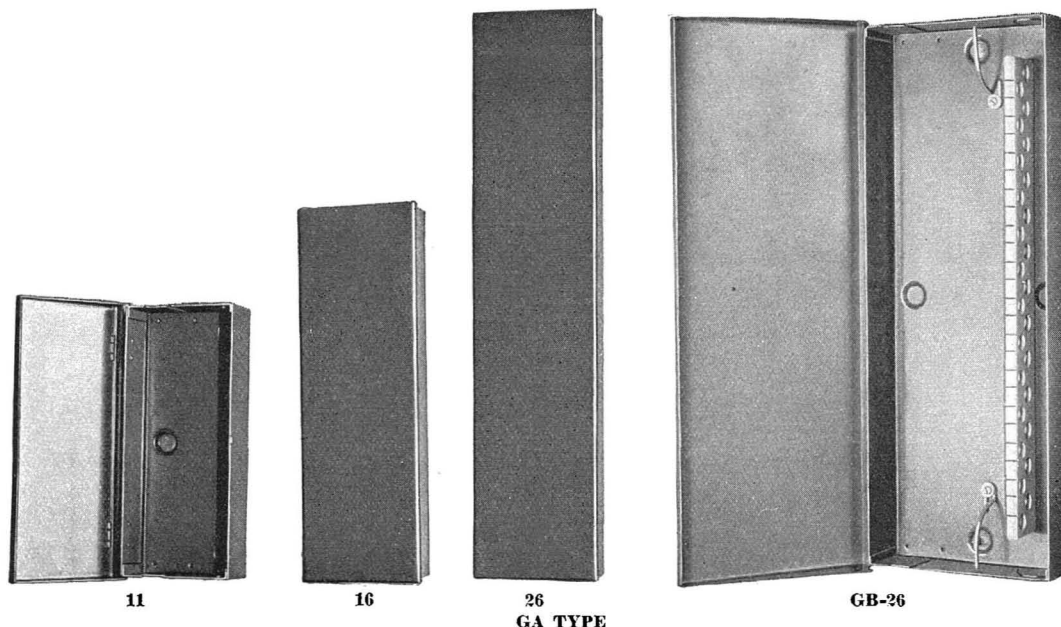

The “GA”, “GB” and “GC” Type Cable Terminal Boxes consist of a sheet metal box having a hinged cover. Knockouts are provided in both ends of the boxes for cable and wires. Screws are provided with the boxes for mounting binding post chambers and adapters.

Type “GA” Cable Terminal Boxes

Intended for use in housing binding post chambers or adapters for connecting blocks. Provided with holes for mounting two No. 8A distributing rings.

Type	Arranged For	Overall Dimensions (Inches)		
		Height	Width	Depth
GA11	1 G11 Binding Post Chamber or 1 No. 102B Adapter	10 ³ / ₁₆	4 ¹ / ₈	2 ¹ / ₂
GA16	1 G16 Binding Post Chamber or 1 No. 102C Adapter	13 ⁵ / ₁₆	4 ¹ / ₈	2 ¹ / ₂
GA26	1 G26 Binding Post Chamber or 1 No. 102D Adapter	19 ⁹ / ₁₆	4 ¹ / ₈	2 ¹ / ₂

Type “GB” Cable Terminal Boxes

Intended for use in housing binding post chambers or adapters for connecting blocks. Provides a more flexible wiring arrangement than the “GA” Type Box. The “GB” Type Box is provided with a fanning strip and two No. 8A distributing rings.

Type	Arranged For	Overall Dimensions (Inches)		
		Height	Width	Depth
GB11	1 G11 Binding Post Chamber or 1 No. 102B Adapter	10 ³ / ₁₆	6 ¹ / ₂	2 ¹ / ₂
GB16	1 G16 Binding Post Chamber or 1 No. 102C Adapter	13 ⁵ / ₁₆	6 ¹ / ₂	2 ¹ / ₂
GB26	1 G26 Binding Post Chamber or 1 No. 102D Adapter	19 ⁹ / ₁₆	7	2 ¹ / ₂

Type “GC” Cable Terminal Boxes

Intended for use in housing binding post chambers or adapters for connecting blocks. Provided with one No. 8A distributing ring.

Type	Arranged For	Overall Dimensions (Inches)		
		Height	Width	Depth
GC3Z	2 G11 or 16 Binding Post Chambers or 2 No. 102B or C Adapters or combination of any two	15 ³ / ₃₂	8 ¹⁵ / ₃₂	2 ¹ / ₂
GC5Z	2 G16 or G26 Binding Post Chambers or 2 No. 102C or D Adapters or combination of any two	21 ⁹ / ₃₂	8 ¹⁵ / ₃₂	2 ¹ / ₂

CABLE TERMINALS (Continued)

TYPE "H" CABLE TERMINAL SECTIONS

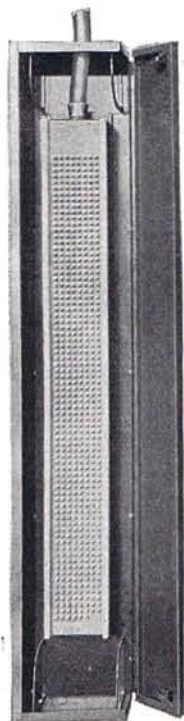

H303 Cable Terminal Section equipped with H Type Binding Post Chamber and 2 J303 Cable Terminal Sections. Door removed

Type	Use	— Overall Dimensions — (Inches)		
		Height	Width	Depth
H102	To provide cross connecting facilities in P.B.X. installations. Intended to house either 2 H51 binding post chambers or 2 82D backboards or 1 H51 binding post chamber and 1 82D backboard. Two J102 cable terminal sections are required for closing the sides of the cable terminal section.	29 $\frac{13}{32}$	14 $\frac{1}{2}$	6
H202	Intended for housing either 1 or 2 H51, H76 or H101 binding post chambers or No. 82A backboards. Two J202 cable terminal sections are required to close the ends of one or a group of H202 sections.	49 $\frac{7}{8}$	14 $\frac{1}{2}$	5 $\frac{3}{16}$
H303	Intended for housing either 1 H303 binding post chamber or 1 82B backboard. Two J303 cable terminal sections are required to close the ends of one or a group of H303 sections.	68	10 $\frac{1}{2}$	6 $\frac{11}{16}$

TYPE "J" CABLE TERMINAL SECTIONS

The "J" Type Cable Terminal Sections consist of a sheet metal end section arranged for closing the ends of one or a group of "H" Type Cable Terminal Sections. Provided with bolts and nuts for fastening to intermediate "H" type sections. A latch is provided at each end for locking the section in a closed position. These cable terminal sections are finished in olive green unless otherwise specified. Available in oak or walnut finishes.

Type	Arranged For	— Overall Dimensions — (Inches)		
		Height	Width	Depth
J102	Closing the sides of one or a group of H102 cable terminal sections.	29 $\frac{1}{4}$	5 $\frac{7}{8}$	1 $\frac{1}{8}$
J202	Closing the ends of one or a group of H202 cable terminal sections.	50	5 $\frac{7}{8}$	1 $\frac{3}{16}$
J303	Closing the ends of one or a group of H303 cable terminal sections.	68 $\frac{1}{8}$	6 $\frac{3}{4}$	1 $\frac{3}{16}$

TYPE K-606 CABLE TERMINAL SECTIONS

The K606 Cable Terminal Section was designed to support H303 Binding Post Chambers and their associated cables or No. 82B Backboards. Two No. 82C Backboards are required to cover the ends of one or a group of K606 Sections.

The K606 Cable Terminal Section consists of a metal framework for supporting Binding Post Chambers and Backboards. It is provided with distributing rings and rods for supporting wires and also facilities for attaching standard cable hooks. The overall dimensions are 12' x 2' 2 $\frac{3}{8}$ " x 1'.

Provided with sleeves, bolts and nuts for fastening sections together; also screws for mounting binding post chambers.

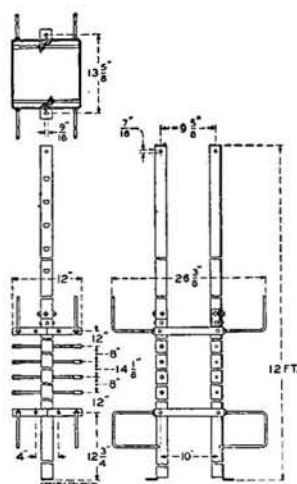

Dimensional Drawing of K606 Cable Terminal Section

CABLE TERMINALS—Continued

Type “L” Cable Terminal Sections

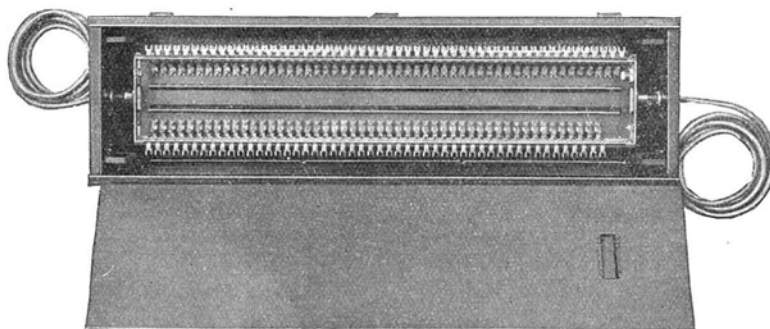

**LB51 Cable Terminal Section consisting of
L51 Cable Terminal Section Equipped with Two M51 Cable Terminal Sections and One LB51 Fuse Chamber**

The “L” Type Cable Terminal Sections consist of a sheet metal intermediate section provided with a door. Knockouts are provided in the top and bottom details for bringing in wires. Screws for mounting fuse chambers or backboards and bolts and nuts for fastening sections together are furnished with each section. These cable terminal sections are finished in olive green unless otherwise specified. Available in oak or walnut finishes.

Type	Use	Height	Overall Dimensions (Inches)	
			Width	Depth
L16	Intended for housing either 1 LA16 or LB16 fuse chamber or 1 No. 83A backboard. Two M16 cable terminal sections are required to close the ends of one or a group of L16 sections.	21¼	12⅛	8⅞
L26	Intended for housing either 1 LA26 or LB26 fuse chamber or 1 No. 83B backboard. Two M26 cable terminal sections are required to close the ends of one or a group of L26 sections.	28¾	12⅛	8⅞
L51	Intended for housing either 1 LA51 or LB51 fuse chamber or 1 No. 83C backboard. Two M51 cable terminal sections are required to close the ends of one or a group of L51 sections.	48¼	12⅛	8⅞

Type “M” Cable Terminal Sections

The “M” Type Cable Terminal Sections consist of a sheet metal end section arranged for closing the ends of one or a group of intermediate sections. Provided with bolts and nuts for fastening to intermediate sections. These cable terminal sections are finished in olive green unless otherwise specified. Available in oak or walnut finishes.

Type	Use	Height	Overall Dimensions (Inches)	
			Width	Depth
M16	At ends of one or a group of L16 cable terminal sections	20¼	7⅜	1⅝
M26	At ends of one or a group of L26 cable terminal sections	27¼	7⅜	1⅝
M51	At ends of one or a group of L51 cable terminal sections	47¼	7⅜	1⅝

CABLE TERMINALS—Continued**Type "B" Binding Post Chambers**

These sealed cable terminating chambers are designed primarily for use in the "B" Type Cable Terminals for terminating aerial cable, and consist in each case of a cast iron case having an insulating face plate in which binding posts are mounted. Fanning strips are provided upon the face plate for leading off the cross-connecting wires. The iron case is finished in black and is supplied with a No. 22 B. & S. Gauge Cable Stub, which is connected in the Chamber and pot-headed.

Code No.		Length of Cable Stub (Inches)	Used with Type "B" Terminal
B26A	Binding Post Chamber.....	25	B26
B51A	Binding Post Chamber.....	33	B51
B76A	Binding Post Chamber.....	36	B76
B76B	Binding Post Chamber.....	50	B152 and B304 (lower)
B76C	Binding Post Chamber.....	88	B304 (upper)
B101A	Binding Post Chamber.....	42	B101
B101B	Binding Post Chamber.....	55	B202 and B404 (lower)
B101C	Binding Post Chamber.....	100	B404 (upper)



B101 "B" Binding Post Chamber

Type "E" Binding Post Chambers

The "E" Type Binding Post Chamber consists of a cast iron chamber provided with an insulated panel with binding posts and a cable stub connected to the binding posts inside of a sealed chamber.

Code No.	Cable Stub	Length of Cable Stub (Inches)	Used with Type "E" Terminal
E26	26 pair 19 gauge lead covered	33	EA26
E51	51 pair 19 gauge lead covered	54	EA51



E51 Binding Post Chamber

CABLE TERMINALS—Continued

Type “G” Binding Post Chambers



G-26 Binding Post Chamber

The “G” Type Binding Post Chamber is intended to provide a moisture-proof seal for lead covered cables terminating in buildings. Arranged to mount in “GA”, “GB” and “GC” Type Cable Terminal Boxes.

Consists of a sheet metal sealing chamber having an insulating panel equipped with binding posts, nuts and washers. Equipped with a 6’, 12’ or 25’ cable stub. Furnished equipped with a 6’ cable stub unless otherwise specified.

The “G” Type Binding Post Chamber can be furnished without a cable stub connected if desired. It can also be obtained in pairs, one chamber connected at each end of a 50’ cable stub when so specified in the order.

Code No.	No. of Pairs of Binding Posts	Mounts in Cable Terminal Box
G-11	11	GA-11
		GB-11
		GC-32
G-16	16	GA-16
		GB-16
		GC-32
		GC-52
G-26	26	GA-26
		GB-26
		GC-52

Type “H” Binding Post Chambers



H-303 Binding Post Chamber

The “H” Type Binding Post Chamber is intended to provide a moisture-proof seal for lead covered cables terminating in buildings.

Each consists of a sheet metal sealing chamber having an insulating panel equipped with binding posts, nuts and washers.

The following binding post chambers are furnished either with a 12’ cable stub or without a cable stub. Equipped with a cable stub unless otherwise specified.

Code No.	Use	No. of Pairs of Binding Posts	Overall Dimensions (Inches)		
			Length	Width	Depth
H-51	Intended to mount in an H-101 or H-202 cable terminal section	51	21 ⁷ / ₈	4 ¹ / ₄	3 ⁵ / ₈
H-76	Intended to mount in an H-202 cable terminal section	76	29 ³ / ₈	4 ¹ / ₄	3 ⁵ / ₈
H-101	Intended to mount in an H-202 cable terminal section	101	37 ¹ / ₂	4 ¹ / ₄	3 ⁵ / ₈
H-303	Intended to mount in either an H-303 or K-606 cable terminal section	303	55 ³ / ₈	6 ⁵ / ₈	4 ⁷ / ₈

CABLE TERMINALS—Continued

Type “B” Fuse Chambers

Primarily for use in the Type “B” Cable Terminals for terminating underground cable. These chambers consist of a cast iron box, finished black and having an insulating face plate provided with threaded posts. Fuses are mounted by screwing one end of the fuse to the binding posts on the chamber face and are held in place at their outer ends by means of a suitable drilled supporting plate of insulating material. This construction effects a substantial saving in the box space required for the installation of the fuse equipment. Fanning strips are mounted on the fuse support plate.

The code numbers given in the table below include the iron fuse chamber complete with threaded posts, fuse support, fanning strips and with a 22 B. & S. Gauge Cable Stub connected and potheaded.

Code No.		Length of Cable Stub (Inches)	Used with Type “B” Terminal
B26A	Fuse Chamber.....	25	B26
B51A	Fuse Chamber.....	33	B51
B76A	Fuse Chamber.....	36	B76
B76B	Fuse Chamber.....	50	B152 and B304 (lower)
B76C	Fuse Chamber.....	88	B304 (upper)
B101A	Fuse Chamber.....	42	B101
B101B	Fuse Chamber.....	55	B202 and B404 (lower)
B101C	Fuse Chamber.....	100	B404 (upper)

Note. The “B” Type Fuse Chambers do not include the fuses, two of which are required for each line. For example, the B26 Fuse Chamber requires 52 No. 7T Fuses, the B51 Fuse Chamber 102 No. 7T Fuses, etc. The required number of fuses should be ordered separately.

Type “LA” and “LB” Fuse Chambers

The “LA” and “LB” Type Fuse Chambers are intended to provide a moisture-proof seal for exposed lead covered cables terminating in buildings.

Each consists essentially of a sealing chamber having a wooden back, metal ends, and sides and face plate made of insulating material. Arranged for but not equipped with Nos. 26 and 27 protector blocks and Nos. 7A and 60D or 60E fuses.

Recommended in place of No. 1079AP Protectors.

“LA” Type: Furnished equipped with a 10’ cable stub.

“LB” Type: Furnished equipped with two 10’ cable stubs.

Code No.	No. of Pairs	Use	Part of Cable Terminal	Overall Dimensions (Inches)		
				Height	Width	Depth
LA16	16	In L16 cable terminal section	LA16	17 ¹ / ₈	10 ¹ / ₁₆	5 ⁷ / ₈
LA26	26	In L26 cable terminal section	LA26	24 ⁵ / ₈	10 ¹ / ₁₆	5 ⁷ / ₈
LA51	51	In L51 cable terminal section	LA51	44 ¹ / ₈	10 ¹ / ₁₆	5 ⁷ / ₈
LB16	16	In L16 cable terminal section	LB16	17 ¹ / ₈	10 ¹ / ₁₆	5 ⁷ / ₈
LB26	26	In L26 cable terminal section	LB26	24 ⁵ / ₈	10 ¹ / ₁₆	5 ⁷ / ₈
LB51	51	In L51 cable terminal section	LB51	44 ¹ / ₈	10 ¹ / ₁₆	5 ⁷ / ₈



B101 “B” Fuse Chamber (with No. 7T Fuses in place)

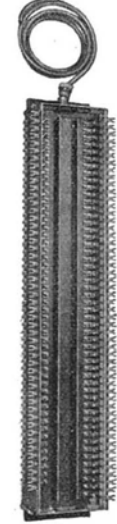

LA51 Fuse Chamber



LB16 Fuse Chamber

CABLE TERMINALS—Continued

Type 102 Adapters

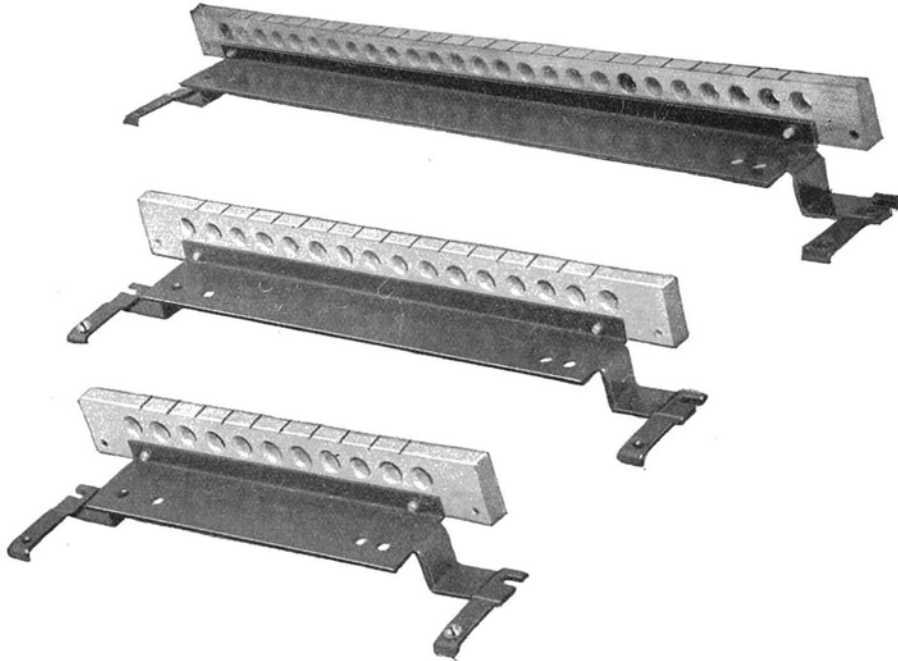

102 Type Adapters (11, 16, 26)

The 102 Type Adapters are intended for mounting No. 30 or No. 31 type connecting blocks in "GA", "GB" and "GC" type cable terminal boxes.

Consists of formed sheet metal mounting plates equipped with a fanning strip, mounting screws and nuts for attaching No. 30 or No. 31 type connecting blocks and a mounting screw for attaching a cable clamp.

Code No.	Mounts in Cable Terminal Box	Overall Dimensions (Inches)
102B	GA11 GB11 GC16	$9\frac{11}{16} \times 2\frac{23}{32} \times 1\frac{1}{8}$
102C	GA16 GB16 GC16 GC52	$12\frac{13}{16} \times 2\frac{23}{32} \times 1\frac{1}{8}$
102D	GA26 GB26 GC52	$19\frac{1}{16} \times 2\frac{23}{32} \times 1\frac{1}{8}$

COMBINED JACKS AND SIGNALS**Ball Type**

Code No.	Approximate Resistance (Ohms)	Used with Plug No.	Description
2C	240	47	Equipped with night bell contact which is closed when target is in operated position. Has single cut-off jack and is intended for use with non-multiple magneto switchboards. When plug is inserted one end of coil winding is disconnected from the line.
4C	240	110	Has night bell contact same as No. 2 Type. Jack arranged with local contact for cutting off signal and is intended for use with multiple magneto switchboards. When plug is inserted one end of coil winding is disconnected from the line.
7C	240	47	Intended for use with non-multiple magneto party lines where selective central office signalling is desired. One side of signal winding brought out to separate terminal for connecting to ground. Has a single cut-off jack. When plug is inserted one end of coil winding is disconnected from the line.

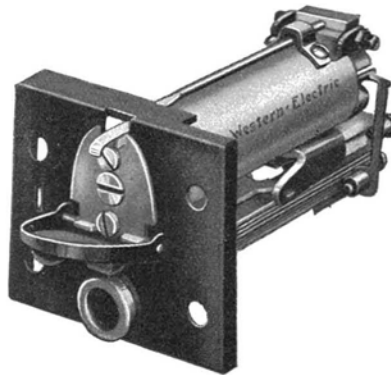
Shutter Type

No. 22 Type on No. 92B Mounting
Signal Operated

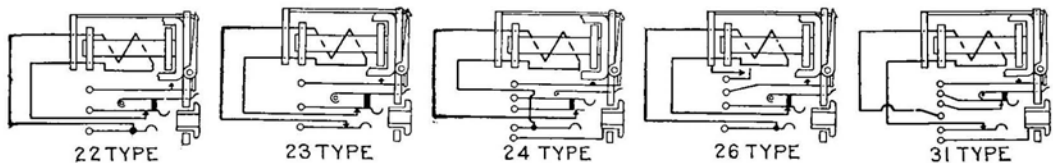

The Shutter Type combined jack and signal is used as a magneto line signal in switchboards where it is desirable to have the jack closely associated with its signal. This arrangement increases the ease and rapidity of operation. The signal is electrically operated and restored mechanically when the plug is inserted in the jack by the operator.

Code No.	Approximate Resistance (Ohms)	Used with Plug No.	Description	Ordinarily Used with Mountings No.
22C	350	47	Equipped with night bell contact, which is closed when shutter is in operated position. Has single cut-off jack and is intended for use with Non-Multiple Magneto Switchboards. When plug is inserted, one end of coil winding is disconnected from the line.	89B or 92B

COMBINED JACKS AND SIGNALS

Shutter Type—Continued

Code No.	Approximate Resistance (Ohms)	Used with Plug No.	Description	Ordinarily Used with Mountings No.
23C	350	47	Same as the No. 22 Type, except has double cut-off jacks. Intended for use with Non-Multiple Magneto Switchboards. When plug is inserted, both ends of coil winding are disconnected from the line.	89B 89D or 92B
24C	350	110	Has night bell contact, same as the No. 22 Type. Jack arranged with local contact for cutting off signal and is intended for use with Multiple Magneto Switchboards. When plug is inserted, one end of coil winding is disconnected from the line.	89C 92C or 101C
26C	350	47	Same as No. 22 Type except that it has on its armature a relay contact, which is made only during the time ringing current flows through the coil. This permits of code signals being received by a bell or buzzer wired in series with the contact. Has a single cut-off jack. Intended for use with Non-Multiple Magneto Switchboards. When plug is inserted one end of coil winding is disconnected from the line.	89B or 92B
31C	350	110	Equipped with night bell contact. Has double cut-off jacks. Intended for use with Multiple, Non-Multiple Magneto or Convertible Switchboards. When plug is inserted, both ends of coil winding are disconnected from the line. Sleeve is brought out to terminal in rear.	89C 92C or 101C

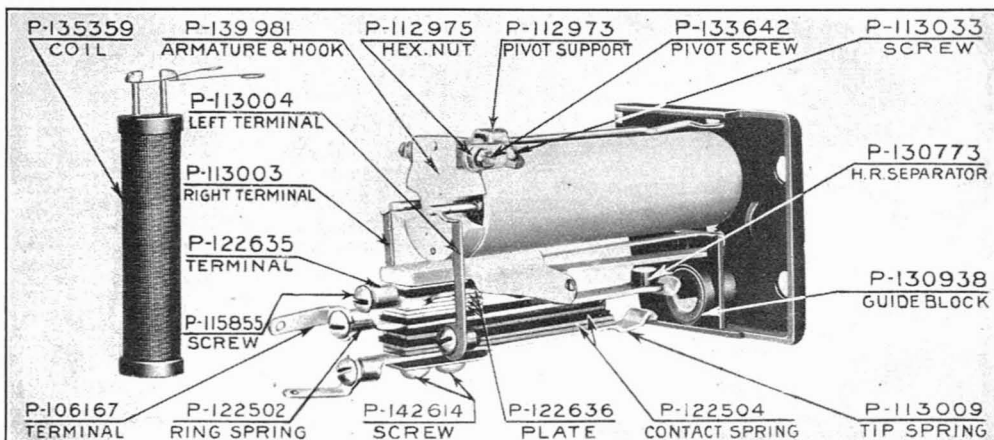
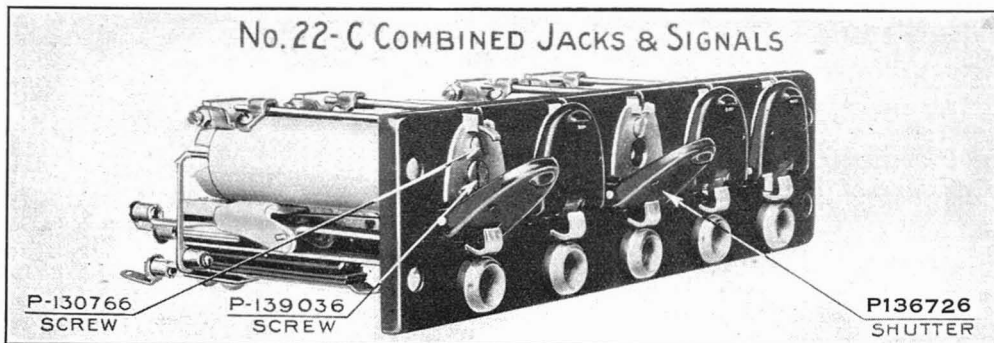

COMBINED JACKS AND SIGNALS—Continued**60 Type**

Code No.	Resistance	Mounting	Used With
60A	82	Single or 5 per strip.	No. 60A jack box.
60D	1000	Single or 5 per strip.	No. 60A jack box.

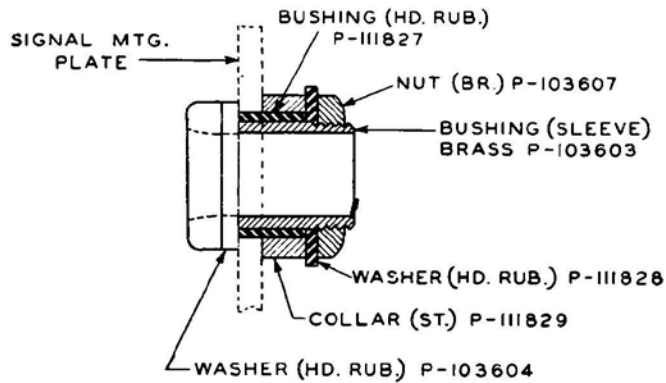

**Replacing Jack Sleeve for
Combined Jacks and Signals**

The above illustration outlines the parts necessary for replacing the sleeve assembly of the Combined Jacks and Signals.

CONDENSERS

GENERAL

Western Electric telephone condensers are of the tinfoil and paper type. The paper dielectric used in separating the tinfoil plates is prepared under rigid specifications from specially selected stock and its high and uniform quality contributes materially to the excellence of the product obtained. The following features of these condensers should be noted:

1. **High and Constant Insulation Resistance.** Not only are the tinfoil and paper units treated with a high grade paraffin wax, but the case in which the units are assembled is entirely filled with waterproofing compound and sealed, thus effectively preventing the entrance of moisture.

2. **High Dielectric Strength.** Each individual condenser is tested to the voltage given in the tables below.

3. **Standard in Size and Shape.** As all these condensers are rectangular in shape, they may be readily mounted occupying a minimum amount of space.

4. **Durable Terminals.** The terminal lugs are mounted on insulating bases, which, when assembled in the condenser are completely covered with moisture-proofing compound. The tinfoil plates are connected to the terminals by annealed flat leads which are also immersed in compound. Bending and heating of the terminals, such as may occur in installing and wiring, will not loosen the connection at the plate.

Condensers—Unmounted Type

These condensers are of the tinfoil and paper type. The paper dielectric used in separating the tinfoil plates is prepared under rigid specifications from specially selected stock and its high and uniform quality contributes materially to the excellence of the product obtained.

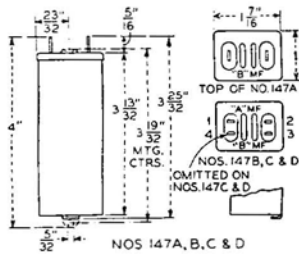

No. 147 Type

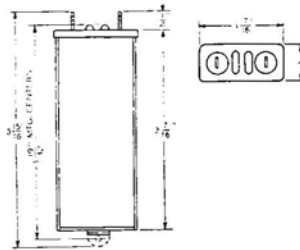

No. 149 Type

The Nos. 147 and 149 Type Condensers are equipped with mounting tabs at lower edge of condenser and may be mounted by means of this tab and a mounting strap.

Safe continuously applied voltage either DC or effective AC at 60 cycles or less and of an approximate sine wave, is 180 volts.

If No. 147 Type Condenser when substituted must fill space of No. 21 Type, order should specify P-409555 Adapter, and for the No. 149 Type Condenser, specify P-409556 Adapter.

Code No.	Capacity M.F.				Voltage Tested On	Used in Sets
	Max.	Stamped At		Min.		
147A	2.50	A ..	B 2.00	2.00	500 D.C.	General. 311A, 1312A, 1314A Sets. Replaces Nos. 21D, E and L Condensers
147B	{ 1.25	1.00	..	1.00	500 D.C.	General. Replaces No. 21BG Condenser
	{ 1.25	..	1.00	1.00		
*147C	{ 1.25	1.00	..	1.00	500 D.C.	Composite. Replaces No. 21AD Condenser
	{ 1.25	..	1.00	1.00		
*147D	{ 1.25	1.00	..	1.00	500 D.C.	Coil Racks. Replaces No. 21N Condenser
	{ .62	..	.5	.5		

* Values stamped at "A" are measured between terminals 1 and 2, values stamped at "B" are measured between terminals 1 and 3.

Code No.	Capacity M.F.			Voltage Tested On	Used in Sets
	Max.	Stamped On Condenser			
149A	1.25	1.	1.0	500 D.C.	General. 502, 1311A, 1312, 1314, 1330, 1331, 1332 Sets. Replaces No. 21F, K, W and BW Condensers
149B	.62	.5	.50	500 D.C.	General. Replaces Nos. 21AC and AS Condensers
149C	.13	.1	.10	500 D.C.	General. Replaces No. 21R Condenser
149D	.80	.65	.65	500 D.C.	General. Replaces No. 21BF Condenser

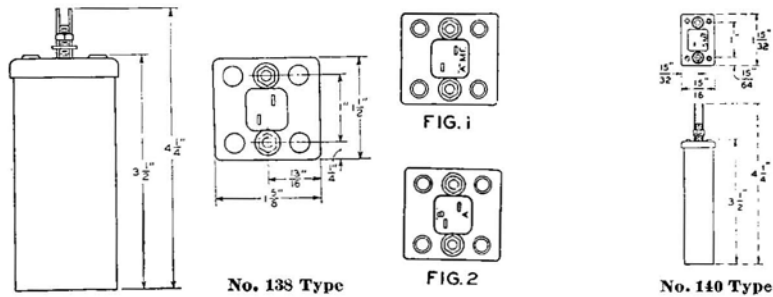
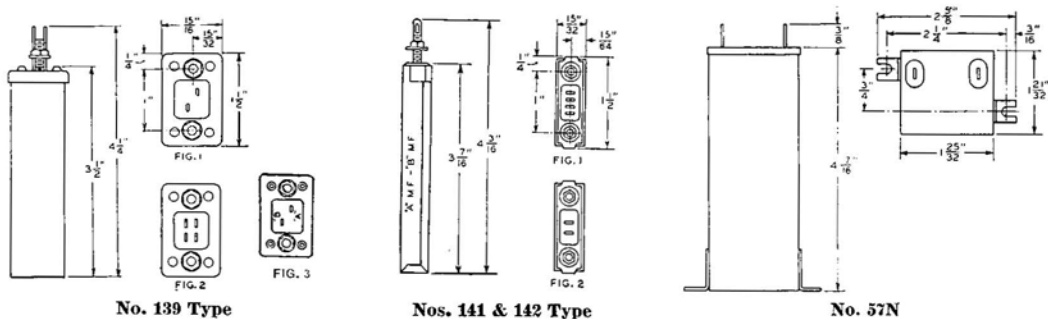
CONDENSERS—Continued**Condensers—Mounting Plate Type****UNMOUNTED TYPE**

The following condensers are for use on relay type mounting plates:

The No. 138 Type Condensers require No. 24 Type Brackets when mounted in place of No. 57 Type Condensers, and No. 27A Brackets when mounted in place of the Nos. 21AA, AU, BE, QA, QB, QC, QD, QE, QF, QG and QH Condensers. Furnished with two nuts and washers for mounting. Arranged to mount on $1\frac{3}{4}$ " vertical and horizontal centers on mounting plates. Safe continuously applied voltage either DC or effective AC at 60 cycles or less and of an approximate sine wave, is 300 volts.

The No. 139 Type Condensers require No. 24 Type Brackets when mounted in place of No. 57 or similar Type Condensers. Furnished with two nuts and washers for mounting. Arranged to mount on 1" horizontal, and $1\frac{3}{4}$ " vertical centers. Safe continuously applied voltage, 200 DC or 180 effective AC at 60 cycles or less and of an approximate sine wave.

The No. 140 Type Condensers are arranged to mount on 1" horizontal and $1\frac{3}{4}$ " vertical centers on mounting plates. Furnished with two nuts and washers for mounting. If the 140B Condenser must have the same mounting arrangement as 21AK Condenser, specify two P-127145 Adapters. Safe continuously applied voltage either DC or effective AC at 60 cycles or less and of an approximate sine wave, is 300 volts.

The No. 141 Type Condensers require No. 24 Type Brackets when mounted in place of No. 57 or similar Type Condensers. Arranged to mount on $\frac{1}{2}$ " horizontal and $1\frac{3}{4}$ " vertical centers. Furnished with two nuts and washers for mounting. Safe continuously applied voltage 200 DC or 180 effective AC at 60 cycles or less and of an approximate sine wave.

If the No. 141H Condenser must fill the space of the No. 21 Type Condensers, order should specify P-409556 Adapter.

If the No. 141J Condenser must fill the space of the No. 21S Condenser, order should specify two P-127145 Adapters.

If the No. 141QF Condenser must mount in the same position as the No. 21AM Condenser, order should specify two P-127145 Adapters.

The No. 142 Type Condensers require one No. 27A Bracket when mounted in place of the No. 21 or similar Type Condensers. Arranged to mount on $\frac{1}{2}$ " horizontal and $1\frac{3}{4}$ " vertical centers. Furnished with two nuts and washers for mounting. Safe continuously applied voltage, either DC or effective AC at 60 cycles or less and of an approximate sine wave, is 300 volts.

Condensers—Mounting Plate Type—Continued

Code No.	Fig. No.	Capacity M.F.				Tested On Voltage	Remarks
		Min.	Stamped On Condenser At		Max.		
			A	B			
57N	—	2.	—	—	—	500 D.C.	Maximum variation M.F. plus 35%
57QF	—	2.14	—	—	2.18	500 D.C.	—
138A	1	1.00	1.	—	1.25	1000 A.C.	Replaces No. 21AA Condenser except for "Additions and Maintenance Only" Replaces No. 57AF Condenser.
138B	—	1.25	1.25	—	1.57	1000 A.C.	Used in Railway Sets.
138QA	2	1.07	1.07	1.09	1.09	1000 A.C.	—
138QB	2	1.04	1.04	1.12	1.12	1000 A.C.	—
139A	1	2.00	2.	—	2.50	500 D.C.	Replaces No. 57A and No. 90B Condensers.
†139B	2	{ 2.00 .02	2. —	— .02	2.50 .03	500 D.C.	Replaces No. 90D Condenser.
†139C	2	{ 1.00 1.00	1. —	— 1.	1.25 1.25	500 D.C.	Replaces No. 21BE and No. 90A Condensers.
139QA	3	2.14	2.14	2.18	2.18	500 D.C.	Replaces Nos. 21QA, QB, QC, QD, QE, QF, QG, QH, ZA, ZB, ZC, ZD, ZE, ZF, ZG, ZH, No. 57K, BD and No. 90C Condensers.
139QB	3	2.10	2.10	2.16	2.16	500 D.C.	Replaces No. 21BE and No. 90E Condensers.
139QC	3	2.16	2.16	2.22	2.22	500 D.C.	Replaces No. 21BE Condenser.
139QD	3	2.08	2.08	2.24	2.24	500 D.C.	—
139QE	3	2.04	2.04	2.16	2.16	500 D.C.	—
139QF	3	2.16	2.16	2.28	2.28	500 D.C.	Replaces No. 21AU and No. 57BK Condensers.
140B	—	.62	—	—	.50	1000 A.C.	Replaces No. 21AK and No. 90F Condensers.
141A	2	1.00	1.	—	1.25	500 D.C.	Replaces No. 57B and No. 89H Condensers.
141D	2	.25	.25	—	.32	500 D.C.	Replaces No. 89E Condenser.
*141E	1	{ .25 .25	{ .25 —	— .25	{ .32 .32	500 D.C.	Replaces No. 21J Condenser.
*141H	1	{ .02 .02	{ .02 —	— .02	{ .03 .03	500 D.C.	Replaces No. 21AH and No. 89B
141J	2	.125	.125	—	.16	500 D.C.	Replaces No. 21S Condenser.
141QF	2	1.08	1.08	1.14	1.14	500 D.C.	Replaces No. 21AM Condenser.
141QP	2	.26	.26	.28	.28	500 D.C.	—
142B	2	.25	.25	—	.32	1000 A.C.	Replaces Nos. 21H, Y and AI Condensers.
142D	2	.05	.05	—	.06	1000 A.C.	Replaces No. 21U Condenser.

† Consists of two separate condensers insulated but not shielded from each other. These condensers should not be used bridged off or across two separate transmission circuits and should not be used in the same circuit where the effect of the capacity between the separate units will be detrimental to the transmission.

* Values stamped at "A" are measured between terminals 1 and 2 and values at "B" are measured between terminals 3 and 4. Consists of two separate condensers insulated but not shielded from each other. These condensers should not be used bridge off or across two separate transmission circuits and should not be used in the same circuit where the effect of the capacity between separate units will be detrimental to transmission.

CONDENSER MOUNTINGS

Condenser Adapters

P-127145—Galvanized iron, overall dimensions $1\frac{1}{32}'' \times \frac{1}{2}''$.

P-409555—Wood, overall dimensions $4\frac{3}{16}'' \times 1\frac{1}{16}''$.

P-409556—Wood, overall dimensions $4\frac{3}{16}'' \times 1\frac{1}{16}''$.

Condenser Brackets

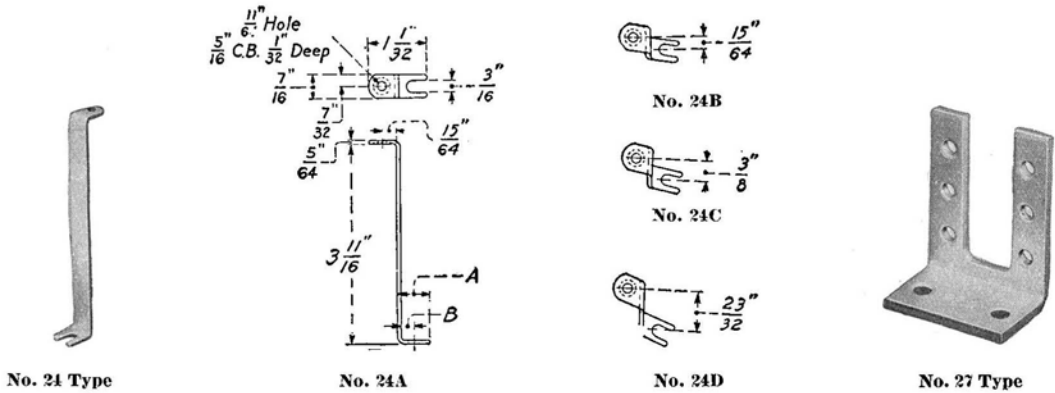

24A—Steel, aluminum finish, overall dimensions $3\frac{11}{16}'' \times \frac{7}{16}'' \times 1\frac{1}{32}''$.

24B—Steel offset, aluminum finish, overall dimensions $3\frac{11}{16}'' \times \frac{7}{16}'' \times 1\frac{1}{32}''$.

24C—Steel offset, aluminum finish, overall dimensions $3\frac{11}{16}'' \times \frac{7}{16}'' \times 1\frac{1}{32}''$.

24D—Steel offset, aluminum finish, overall dimensions $3\frac{11}{16}'' \times \frac{7}{16}'' \times 1\frac{1}{32}''$.

27A—Steel, aluminum finish, overall dimensions $1\frac{1}{2}'' \times 1\frac{1}{8}'' \times 1''$.

27B—Steel, aluminum finish, overall dimensions $1\frac{1}{2}'' \times 1\frac{5}{16}'' \times 1''$.

27C—Steel, aluminum finish, overall dimensions $1\frac{1}{2}'' \times 3\frac{3}{4}'' \times 1''$.

27D—Steel, aluminum finish, overall dimensions $1\frac{1}{2}'' \times 2\frac{7}{16}'' \times 1''$.

Condenser Straps

P43065—A straight galvanized iron strap, overall dimensions $4\frac{5}{16}'' \times \frac{1}{2}''$

P43121—A galvanized iron clamp, overall dimensions $5\frac{3}{16}'' \times \frac{9}{16}''$.

P48022—A straight galvanized iron strap for mounting two condensers, overall dimensions $9\frac{5}{8}'' \times \frac{1}{2}''$.

CONNECTING BLOCKS



No. 1A

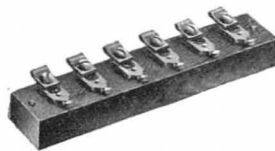

No. 8A

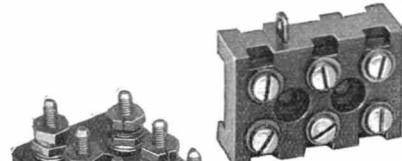

No. 12E



No. 11A

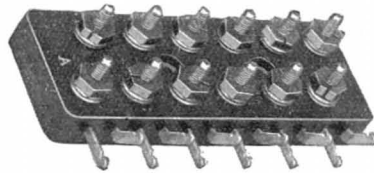

No. 31A

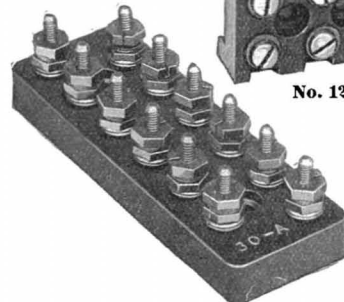

No. 30A

Code	No. of Connectors	Description	Size of Base, Ins.			Material Base
			Length	Width	Thickness	
1A	3	$2\frac{1}{32}$	$2\frac{1}{32}$	$1\frac{3}{32}$	Composition
8A	6	{ One screw and cord tip terminal on each connector.	5	1	$\frac{5}{8}$	Ebonized wood
11A	2	{ Two screw terminals on each connector. Opposite terminals are electrically connected.	$1\frac{1}{8}$	$1\frac{3}{32}$	$\frac{9}{16}$	Composition
(a) 11B	2					
(b) 11C	2					
12E	3	{ Two screw terminals on each connector. Has 3 slots in under side of base. Opposite terminals are electrically connected. Replaces Nos. 12C and D.	$1\frac{11}{16}$	$1\frac{3}{8}$	$1\frac{11}{16}$	Composition
(c) 12F	3					
18A	15	{ For use with No. 209 Type Relays. Adapted to mount on mounting plates of No. 823 or similar Type.	$2\frac{31}{64}$	$2\frac{1}{32}$	$1\frac{25}{32}$
18B	8	{ Same as 18A except for use with No. 215 Type Relays.	$2\frac{31}{64}$	$2\frac{1}{32}$	$1\frac{25}{32}$
18F	10	{ Same as 18A except for use with No. 228 Type Relays.	$2\frac{31}{64}$	$2\frac{1}{32}$	$1\frac{25}{32}$
26B	4	{ For use with No. 218B Relays. Adapted to mount on mounting plates $\frac{1}{32}$ " thick.	$3\frac{1}{8}$	$1\frac{7}{32}$	$2\frac{11}{16}$
30A	12	{ Binding posts have lock nuts, with posts spun over to prevent loss of lock nuts.	$4\frac{3}{16}$	$1\frac{1}{2}$	$1\frac{1}{2}$	Composition
30B	22		$7\frac{3}{16}$	$1\frac{1}{2}$	$1\frac{1}{2}$	Composition
30C	32		$10\frac{9}{16}$	$1\frac{1}{2}$	$1\frac{1}{2}$	Composition
30D	52		$16\frac{11}{16}$	$1\frac{1}{2}$	$1\frac{1}{2}$	Composition
31A	12		{ Each connector has one lock nut binding post and one soldering terminal, brought out on the side.	$4\frac{3}{16}$	$1\frac{1}{2}$	$1\frac{1}{2}$
31B	22	$7\frac{3}{16}$		$1\frac{1}{2}$	$1\frac{1}{2}$	Composition
31C	32	$10\frac{9}{16}$		$1\frac{1}{2}$	$1\frac{1}{2}$	Composition
31D	52	$16\frac{11}{16}$		$1\frac{1}{2}$	$1\frac{1}{2}$	Composition
33A	2	{ For use in providing a source of battery and ground for testing purposes at distributing frames, and in rear of switchboards. Arranged to be clamped on the side of the base of terminal strips and are adapted for bases either $\frac{5}{8}$ inch or $\frac{3}{4}$ inch. Engraved "24 V."		$2\frac{13}{32}$	$\frac{9}{16}$	$1\frac{19}{32}$
33B	2	{ Same as No. 33A except engraved "48 V."	$2\frac{13}{32}$	$\frac{9}{16}$	$1\frac{19}{32}$	Composition
35A	8	{ For grouping together the cord circuits of adjacent positions in No. 551 PBX Switchboard. Consists of a "B1" Type Key Base and mounting stud assembly.	$4\frac{9}{16}$	$1\frac{1}{32}$

(a) The No. 11B consists of a No. 11A equipped with a black finished metal cover.
 (b) The No. 11C is the same as No. 11B except that the under-surface of the top of the cover is provided with an insulating strip to protect the terminals from short circuits.
 (c) The No. 12F consists of a No. 12E equipped with a black finished metal cover.

CORDS**General**

Western Electric telephone cords are the result of more than fifty years experience in the manufacture of telephone apparatus. They are of the same high quality that has characterized all Western Electric telephone equipment and caused it to be recognized as standard by the leading telephone authorities throughout the world.

These cords are all of the tinsel alloy type and will be found to have exceptional wearing qualities.

Switchboard Cords**CONSTRUCTION**

The description of the steps taken in the manufacture of these tinsel cords which is given below, will show the care exercised in producing superior cords which are suitable for all classes of switchboard service. These steps are as follows:

1. Two metal ribbons are wound around a strong cotton thread to form a tinsel thread. This tinsel thread is of special manufacture and made under the Western Electric Company's own rigid specifications. The characteristic most strongly emphasized is freedom from noise after long service.

2. Six of the above tinsel threads are wound around a strong cotton twine to form a conductor, thus giving the conductor great flexibility.

3. Each conductor is covered with two servings (wrappings) of Tussah Floss Silk for the purpose of insulation.

4. These silk insulated conductors are then impregnated with an asphaltic moisture proofing compound. This compound is flexible, does not harden with age, and minimizes corrosion.

5. After this moisture-proofing is applied each conductor is further insulated and protected by means of a cotton braiding.

6. Two or three of these conductors are then twisted together to form the body of the cord.

7. In order that the external surface of the cord may be smooth, the spaces between the twisted conductors are filled with cotton twine.

8. The body of the cord is then given a tight serving of cotton to hold the conductors firmly in place.

9. The plug end of the cord is suitably reinforced to allow for the severe bending and handling which occurs at this point.

10. An outside braiding of glazed cotton is then applied over the entire length of the cord.

Long experience in actual service has shown that this is the most satisfactory method of cord construction yet devised, not only as regards wearing qualities, but also as to electrical and operating features.

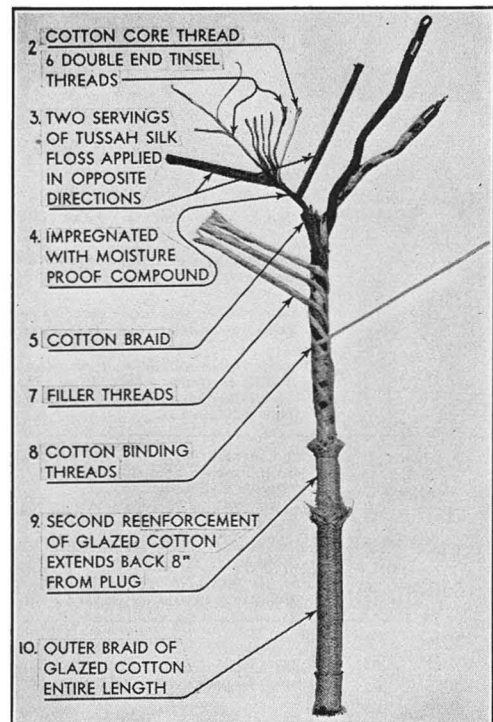

Switchboard Cords—Continued

ADVANTAGES

Under actual service conditions the following features of this type of cord have been proven conclusively:

1. Extremely long life.
2. The moisture-proofing feature makes their use possible in damp and humid climates for long periods without the necessity of making frequent changes.

Dampness from the operator's hands has practically no effect on these cords.

3. The resistance of each conductor is approximately 1 ohm (6 ft. cord).
4. The current carrying capacity of each conductor is 3 amperes which is much greater than is ever necessary in telephone service.
5. Cords having either white, red, green or black braiding can be supplied. If no color is specified, however, white cords will be furnished.

In ordering cords specify length desired. Lengths shown on illustrations are stock lengths.

If cords are desired equipped with the plugs listed, that fact should be mentioned in the order and the code number of the plug should be specified.

MOISTURE-PROOFED

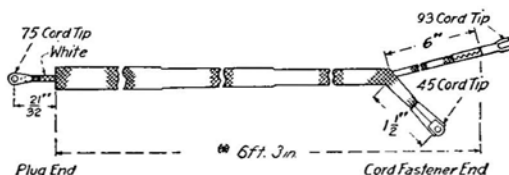

Code S1A S1A 1 Conductor

(*) 4 ft. cords can be furnished when specified.

Arranged for 116 Plug.

Replaces 511.

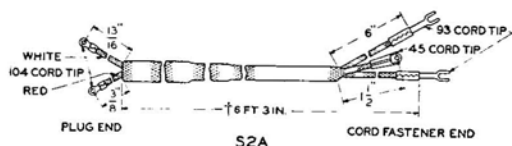

Code S2A S2A 2 Conductors

(†) 3 ft., 4 ft., or 8 ft. cords can be furnished when specified.

Arranged for 27, 32, 47, 53 and 65 Plugs.

Replaces 493.

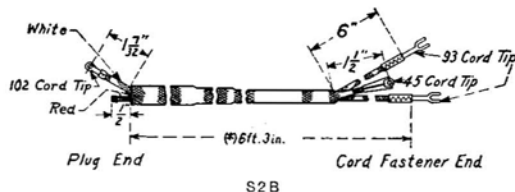

Code S2B S2B 2 Conductors

(*) 4 ft. or 8 ft. cords can be furnished when specified.

Arranged for 110 Plug.

Replaces 635.

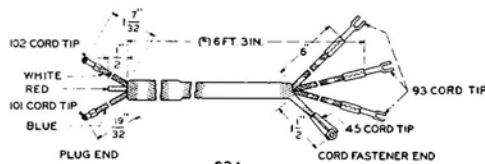

Code S3A S3A 3 Conductors

(*) 2 ft., 6 ft., or 8 ft. cords can be furnished when specified.

Arranged for 109 Plug.

Replaces 447 and S3E.

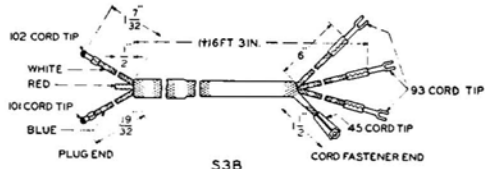

Code S3B S3B 3 Conductors

(†) 4 ft., 5 ft., or 8 ft. cords can be furnished when specified.

Arranged for 110 Plug.

Replaces 448.

Switchboard Cords—Continued

OPERATORS' TELEPHONE CORDS

These cords are designed for use in connection with switchboard operators' transmitter and receiver equipment.

Standard tinsel cords with especially treated brown cotton insulation.

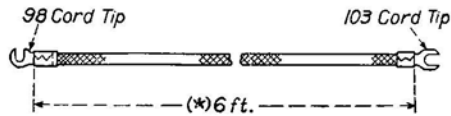

Transmitter End 330 1 Conductor

(*) 5 ft. cords can be furnished when specified. Intended for use on P.B.X. switchboard. Note: Shank of 98 Cord Tip insulated.

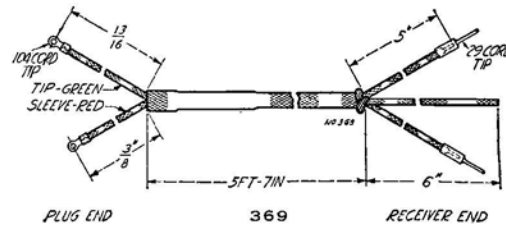

Code 369 2 Conductors

Arranged for 136 Plug. Intended for use with 128 Receiver in connection with Nos. 1200 or 1360 series switchboards when a suspended transmitter is used.

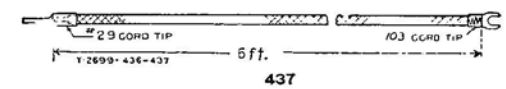

Code 437 1 Conductor

Intended for use with transmitter arms or suspended type transmitters. With 330 cord replaces No. 37. Replaces 25 and 27.

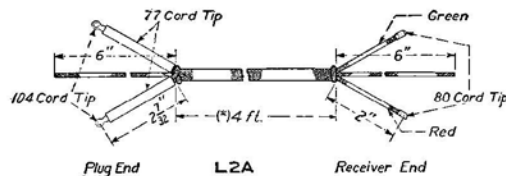

Code L2A 2 Conductors

(*) 5 ft. 6 in. cords can be furnished when specified. Arranged for 528 Receiver and 137 or similar type Plug. Recommended in place of L2E and L2G. Note: When ordered equipped with Plug, cord will be connected to sleeve terminals unless otherwise specified.

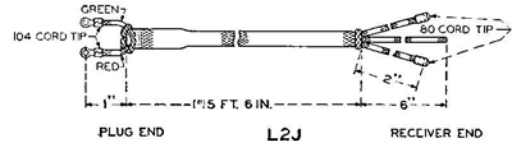

Code L2J 2 Conductors

(*) 4 ft. cords can be furnished when specified. Arranged for 528 Receiver and 148 Plug. Recommended in place of L2F.

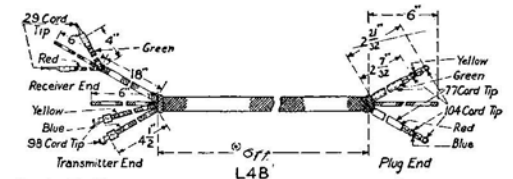

Code L4B 4 Conductors

(*) 6 ft. or 10 ft. cords can be furnished when specified. Arranged for 137 or similar type Plug, 128 Receiver and 234 Transmitter. Replaces 87. Note: Shanks of 98 Cord Tips insulated.

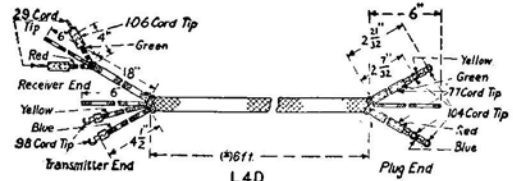

Code L4D 4 Conductors

(*) 6 ft. or 10 ft. cords can be furnished when specified. Arranged for 137 or similar type Plug, 128 Receiver and 234 Transmitter. Replaces 748. Note: Shanks of 98 Cord Tips insulated.

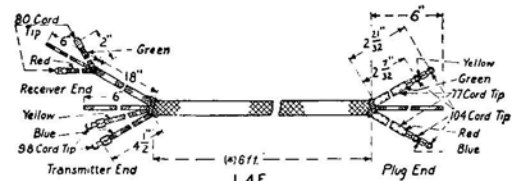

Code L4E 4 Conductors

(*) 6 ft. or 10 ft. cords can be furnished when specified. Arranged for 137 or similar type Plug, 528 Receiver and 234 Transmitter. Replaces 848. Note: Shanks of 98 Cord Tips insulated.

Switchboard Cords

OPERATORS' TELEPHONE CORDS—Continued

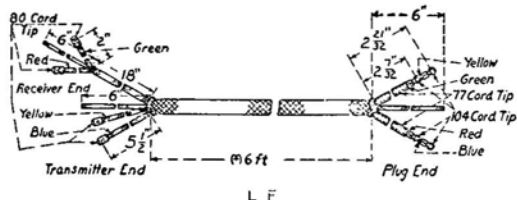

L F

Code LAF 4 Conductors

(*) 6 ft. or 10 ft. cords can be furnished when specified.

Arranged for 137 or similar type Plug, 528 Receiver and 396A Transmitter.

Recommended in place of the L4B, L4D and L4E.

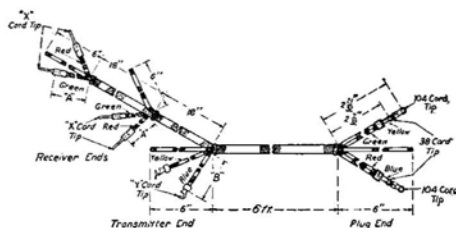

L6A

Intended for use as operator's parallel double head receiver and breast transmitter.

Code No.	Dimensions (Inches)		Cord Tip		Arranged For	
	A	B	X No.	Y No.	Receiver No.	Transmitter No.
(a) L6A	4	4 1/2	29	98	128A	234
L6C	2	5 1/2	80	80	528	396A

Each is arranged for a 137 Plug.

The L6A replaces the 864 cord.
(a)—Shanks of 98 Cord Tips insulated.

Miscellaneous Central Office Cords

The following miscellaneous Central Office Cords are standard tinsel cords with especially treated cotton insulation, moisture-proofed unless otherwise specified.

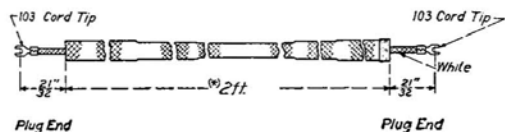

P1A

Code P1A Patching 1 Conductor

White.

(*) 1 ft., 4 ft., or 6 ft. cords can be furnished when specified.

Arranged for 116 Plug.

Replaces 510.

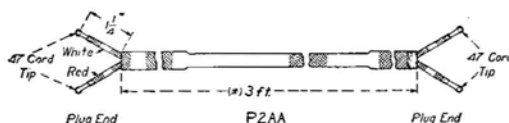

P2AA

Code P2AA Patching 2 Conductors
White.

(*) 1 ft., 2 ft., 4 ft., or 6 ft. cords can be furnished when specified.

Arranged for two 241 type Plugs (tip connections).
Replaces 855.

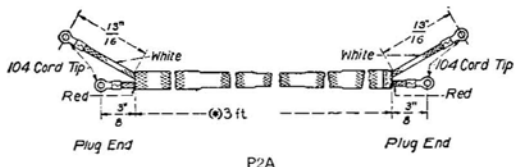

P2A

Code P2A Patching 2 Conductors

Red.

(*) 1 ft., 2 ft., 4 ft., or 6 ft. cords can be furnished when specified.

Arranged for 47 type Plug.

Replaces 516.



P2B

Code P2B Patching 2 Conductors

Green.

(*) 1 ft., 2 ft., 4 ft., or 6 ft. cords can be furnished when specified.

Arranged for 110 type Plug.

Replaces 515.

Miscellaneous Central Office Cords—Continued

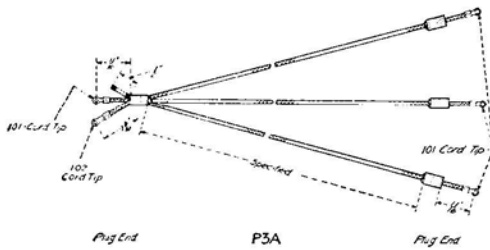

Code P3A (Not moisture-proofed) **3 Conductors**
Brown.

3 ft. standard length cord will be furnished unless otherwise specified.

Intended for use in emergency plugging-up to make a line busy.

Arranged for 110 Plug.

Note: One end of cord arranged for connections to the tip, ring and sleeve of a single plug and the other end for connections to the rings of three plugs.

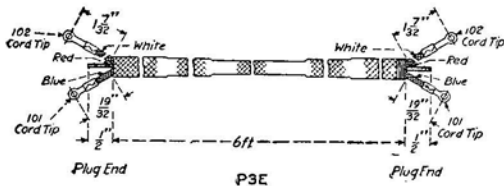

Code P3E Patching **3 Conductors**

White.

Arranged for 110 Plug.

Replaces 728.

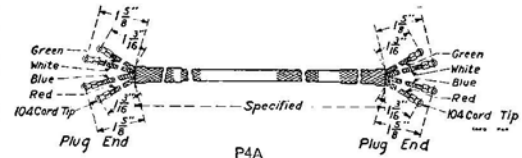

Code P4A Patching **4 Conductors**

White, red, green and black. White furnished unless otherwise specified.

Standard Lengths: 1 ft., 2 ft., 3 ft., 4 ft., or 6 ft.

2 ft. cords furnished unless otherwise specified.

Arranged for 154 Plug.

Replaces 659.

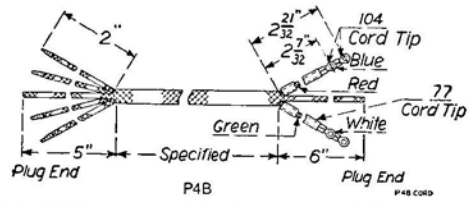

Code P4B Patching **4 Conductors**

Black.

Standard Length: 10 ft.

Arranged for 152 and 240B, or 240C Plugs.

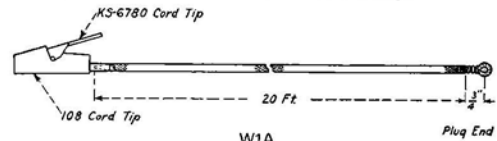

Code W1A For Service Observing **1 Conductor**

Green.

Standard Length: 20 ft.

Arranged for 144 Plug.

Replaces 524.

Telephone Set Cords

GENERAL

In ordering cords specify length desired. Lengths shown on illustrations are stock lengths.

STANDARD TINSEL CORDS

These cords are standard for regular telephones, and include deskstand cords, handset and handset mounting cords, receiver cords and transmitter cords for all types of equipment.

The conductors are composed of the same high grade tinsel described under Switchboard Cord Construction (Page 52), unless otherwise specified.

The following cords have the individual conductors insulated with two braidings of cotton. The required number of conductors are covered with a final braiding of brown silk or cotton as specified on the following pages.

Colored tracer threads are woven into the braiding of the individual conductors, so that each conductor may be easily identified.

MOISTURE-PROOFED TELEPHONE SET CORDS

This type of cord was originally designed for railway telephone service, where cords are subjected to more severe service conditions than are usually met with in ordinary telephone service. The design, however, has been improved and enlarged until we are now prepared to furnish moisture-proofed cords for practically all classes of telephone service.

WATER-PROOFED CORDS

These cords have the individual tinsel conductors covered with a double serving of cotton to keep the rubber away from the tinsel. The conductors are then covered with a high grade of rubber after which the braiding is applied. They are designed for use in connection with mine telephones, portable telephones, or other equipment used out-of-doors, underground, or wherever considerable moisture, dampness or gaseous fumes are present. These cords have a black cotton braiding.

Deskstand, Handset and Handset Mounting Connecting Cords

The following cords have standard tinsel conductors, unless otherwise specified.

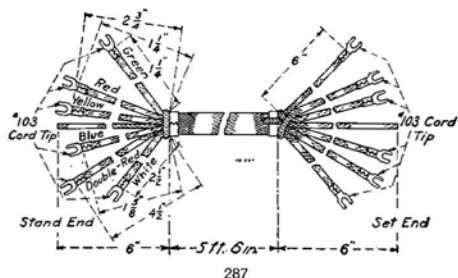

Code 287 (Moisture-proofed) **6 Conductors**
Brown Cotton Covered.
Intended for use with 40S Transmitter Arm.
Forms a part of 468 Cord.
Replaces 339.

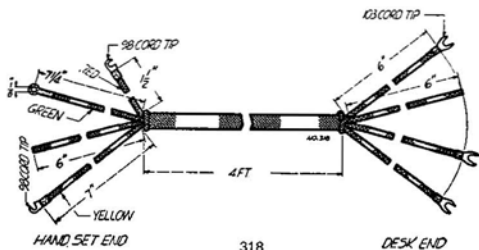

Code 318 **3 Conductors**
Brown Cotton Covered.
Intended for use with 1002AC Handset.

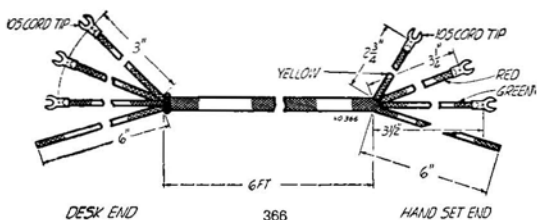

Code 366 **3 Conductors**
Black Cotton Covered.
Intended for use with 1001C Handset.

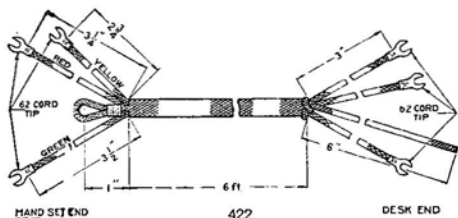

Code 422 **3 Conductors**
(Water-proofed Rubber Covered Conductors)
Black Cotton Covered.
Intended for use with 1001H Handset; also with 278 Type Subscriber Set with 1C Handset Handle.
Replaces 420.

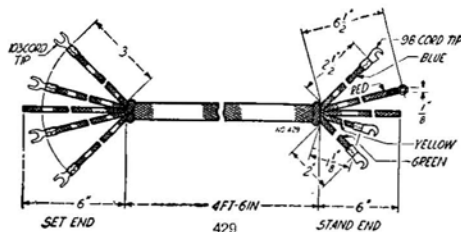

Code 429 **4 Conductors**
Gray Cotton Covered.
Intended for use with 1002D Handset.

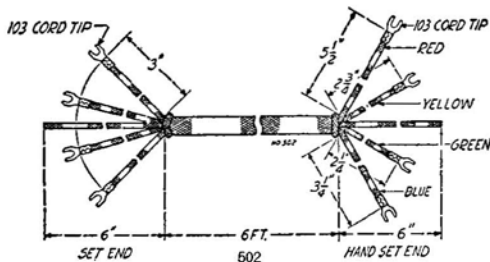

Code 502 **4 Conductors**
Gray Cotton Covered.
Intended for use with 1001J Handset. **6 Ft.**

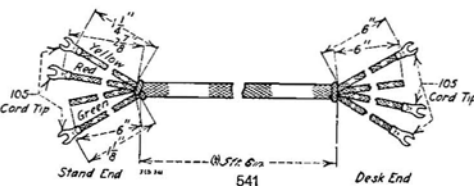

Code 541 **3 Conductors**
(Water-proofed Rubber Covered Conductors)
Brown Cotton Covered.
Intended for use with 40P Transmitter Arm in place of 550 Cord where a water-proofed cord is required.

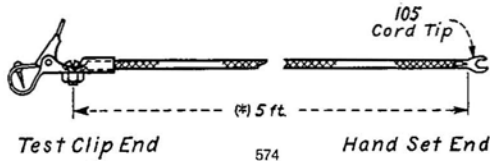

Code 574 **1 Conductor**
(Water-proofed Rubber Covered Conductors)

* 3 foot cords also available.
Black Glazed Cotton Covered.
Intended for use with 1001A Handset.
Note: Equipped with test clip.
Replaces 348.

Deskstand, Handset and Handset Mounting Connecting Cords—Continued

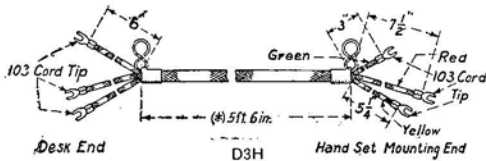

Code D3H Type **3 Conductors**

(*) 9 ft., 13 ft., or 25 ft. cords can be furnished when specified.

Intended for connecting B1 or D1 Handset Mountings to Subscriber Sets or Connecting Blocks. D3H9 is also for use with 51AL, 51CM, 51CN or 52AB Deskstands.

Code	Color	Outer Covering
D3H4	Ivory	Silk
D3H5	Gray	Silk
(a)D3H9	Brown	Cotton
D3H10	Dark Brown	Silk
D3H11	Gold	Silk

(a) Moisture-proofed.

D3H9 replaces D3A.

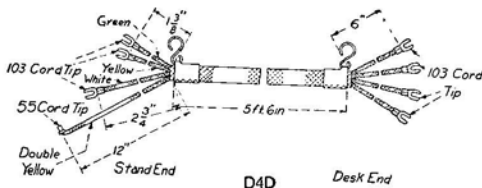

Code D4D (Moisture-proofed) **4 Conductors**

Brown Cotton Covered.

Intended for use with 20AH or 40AH Deskstands. Replaces 529.

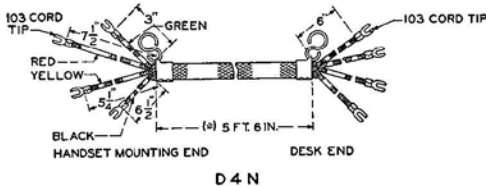

Code D4N Type **4 Conductors**

(*) 9 ft., 13 ft., or 25 ft. cords can be furnished when specified.

Intended for use with B1 Type Handset Mounting or 202 Type Hand Telephone Sets. D4N9 is also for use with 20AL, 20BS, 20BU, 20CF or 40AL, 40BS, 40BU, 40CF Deskstands.

Code	Color	Outer Covering
D4N4	Ivory	Silk
D4N5	Gray	Silk
D4N9	Brown	Cotton
D4N10	Dark Brown	Silk
D4N11	Gold	Silk

The D4N9 replaces the D4B.

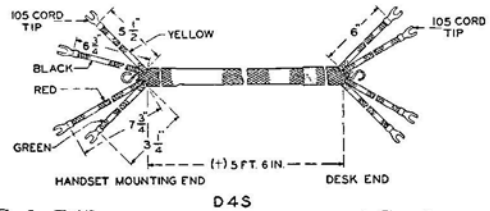

Code D4S **4 Conductors**
(Water-proofed Rubber Covered Conductors)
Cotton Covered.

(†) 9 ft., or 13 ft. cords can be furnished when specified.

Intended for use in place of D4N9 when a water-proofed cord is required. Replaces D4H.

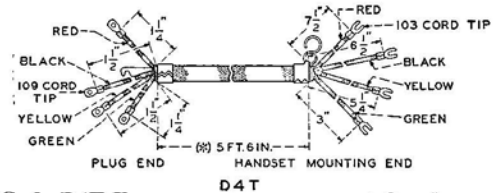

Code D4T Type **4 Conductors**

(*) 9 ft., 13 ft., or 25 ft. cords can be furnished when specified.

Intended for use with 202 Type Hand Telephone Sets for portable service. D4T9 is also for use with 120AL, 140AL, 151AL, or 152AB Deskstands.

Arranged for 283A Plug.

Code	Color	Outer Covering
D4T4	Ivory	Silk
D4T5	Gray	Silk
(a)D4T9	Brown	Cotton
D4T10	Dark Brown	Silk
D4T11	Gold	Silk

(a) Moisture-proofed.

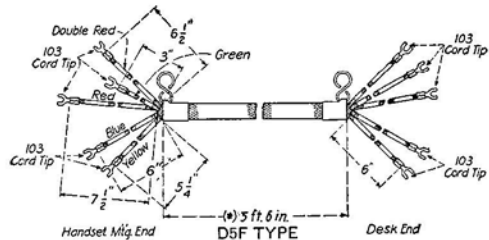

Code D5F Type **5 Conductors**

(*) 9 ft., or 13 ft. cords can be furnished when specified.

Intended for use with B2, D2 or similar type Handset Mountings. D5F9 is also for use with 40R, 40CN, 51C, or 51CN Deskstands.

Code	Color	Outer Covering
D5F4	Ivory	Silk
D5F5	Gray	Silk
(a)D5F9	Brown	Cotton
D5F10	Dark Brown	Silk
D5F11	Gold	Silk

(a) Moisture-proofed.

D5J recommended when a water-proofed cord is required.

D5F9 cord replaces the D5A.

Deskstand, Handset and Handset Mounting Connecting Cords—Continued

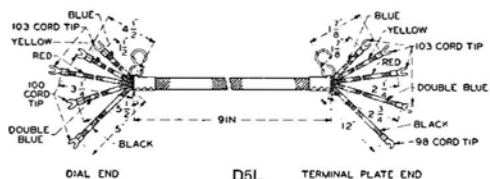

Code D5L **5 Conductors**

Brown Cotton Covered.

Intended for use with 151AL Deskstand.

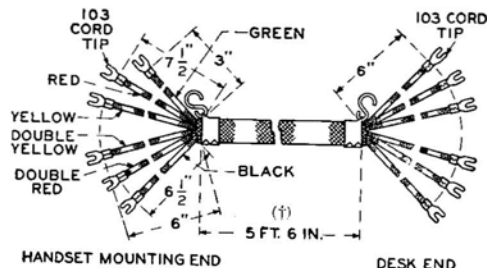

Code D6H Type **6 Conductors**

(†) Length 4 ft., but 9 ft. and 13 ft. cords can be furnished when specified except D6H9—Lengths 5 ft. 6 in., but 4 ft. 9 in. and 13 ft. cords can be furnished when specified.

Intended for use with 203 Type Hand Telephone Sets and B6 Type Handset Mountings. D6H9 is also for use with 151C Deskstand.

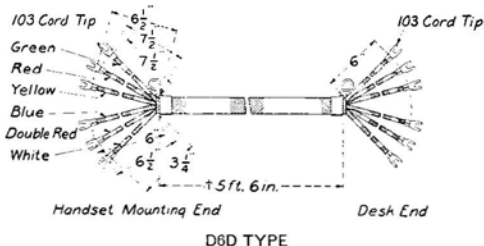

Code D6D Type **6 Conductors**

(†) 4 ft., 9 ft., 13 ft., or 25 ft. cords can be furnished when specified.

Intended for use with 206 or 207 Type Hand Telephone Sets. D6D9 is also for use with 20CN, 50CN, 151S, 151AL Deskstands.

Code	Color	Outer Covering
D6D4	Ivory	Silk
D6D5	Gray	Silk
D6D9	Brown	Cotton
D6D10	Dark Brown	Silk
D6D11	Gold	Silk

The D6D9 replaces the 287 Cord and the D6A Cord for use with Nos. 20CN or 40CN Deskstands.

Code	Color	Outer Covering
D6H4	Ivory	Silk
D6H5	Gray	Silk
(a)D6H9	Brown	Cotton
D6H10	Dark Brown	Silk
D6H11	Gold	Silk

(a) Moisture-proofed.

Specify D6J cord when a water-proofed (rubber covered conductor) cord is required.

Code D6J **6 Conductors**

(Water-proofed Rubber Covered Conductors)

Intended for use in place of D6H9 where a water-proofed cord is required.

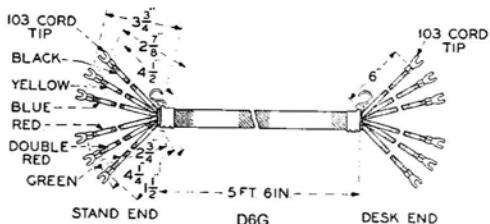

Code D6G (Moisture-proofed) **6 Conductors**

Brown Cotton Covered.

Intended for use with 151R Deskstand.

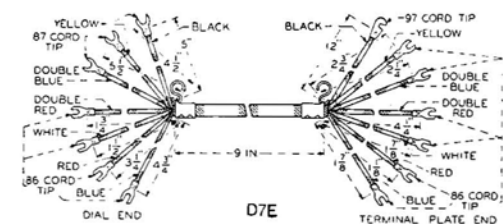

Code D7E (Moisture-proofed) **7 Conductors**

Brown Cotton Covered.

Intended for use with 151C Deskstand.

Conductors 22 A.W.G. Stranded Copper.

Deskstand, Handset and Handset Mounting Connecting Cords—Continued

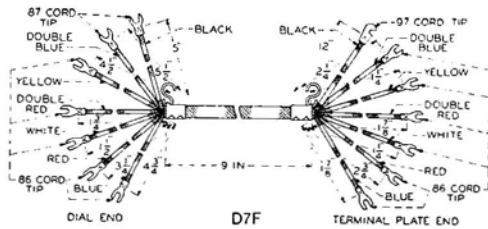

Code D7F (Moisture-proofed) **7 Conductors**
Brown Cotton Covered.
Intended for use with 151R Deskstand.
Conductors 22 A.W.G. Stranded Copper.

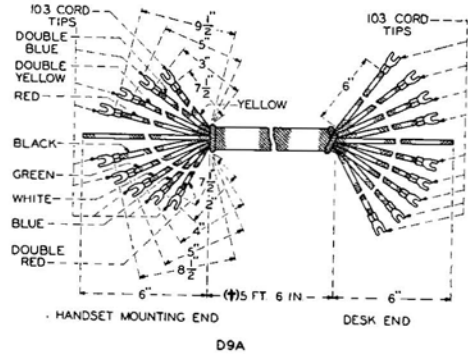

Code D9A Type **9 Conductors**
Intended for use with 205D, 205E, or 205F Type
Hand Telephone Sets.

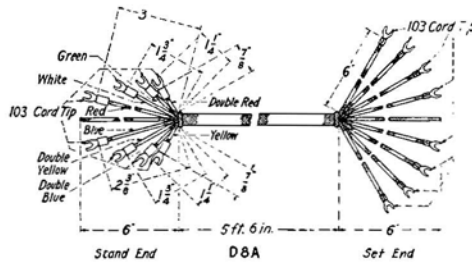

Code D8A (Moisture-proofed) **8 Conductors**
Intended for use with 50G Deskstand.

Code	Color	Outer Covering
D9A4	Ivory	Silk
D9A5	Gray	Silk
(a)D9A9	Brown	Cotton
D9A10	Dark Brown	Silk
D9A11	Gold	Silk
(a) Moisture-proofed.		

Note: Shanks of 103 Cord Tips on the Handset Mounting end are insulated to prevent crosses.

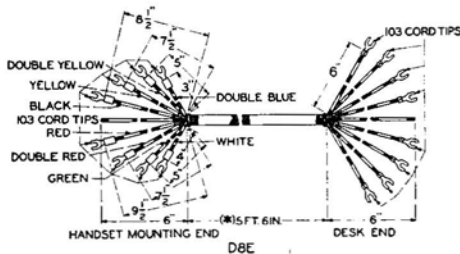

Code D8E Type **8 Conductors**
Intended for use with 205A, 205B or 205C Type
Hand Telephone Sets.

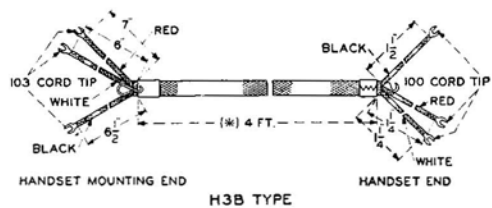

Code H3B Type **3 Conductors**
(*) 9 ft. cords can be furnished when specified.
Intended for use with E1B Type Handsets.

Code	Color	Outer Covering
D8E4	Ivory	Silk
D8E5	Gray	Silk
(a) D8E9	Brown	Cotton
D8E10	Dark Brown	Silk
D8E11	Gold	Silk
(a) Moisture-proofed.		

Code	Color	Outer Covering
H3B4	Ivory	Silk
H3B5	Gray	Silk
(a)H3B9	Brown	Cotton
H3B10	Dark Brown	Silk
H3B11	Gold	Silk
(a) Moisture-proofed.		

Deskstand, Handset and Handset Mounting

Connecting Cords—Continued

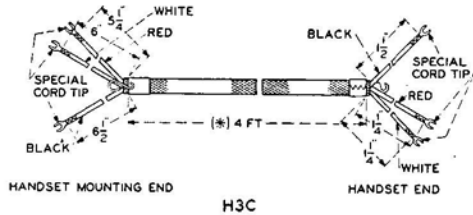

H3C

Code H3C **3 Conductors**

(Water-proofed Rubber Covered Conductors)

Brown Cotton Covered.

Intended for use in place of H3B9 where a water-proofed cord is required.

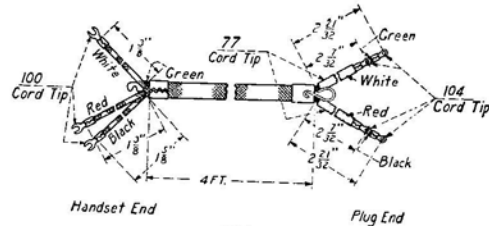

H4C

Code H4C **4 Conductors**

Brown Silk Covered.

Intended for use with E2A-3 Handsets.

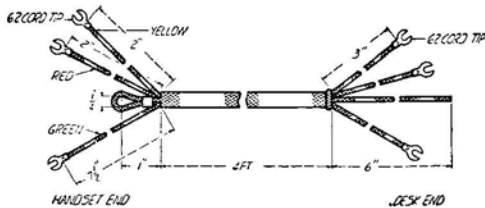

H3D

Code H3D **3 Conductors**

(Water-proofed Rubber Covered Conductors)

Black Cotton Covered.

Intended for use with 1001N Handset.

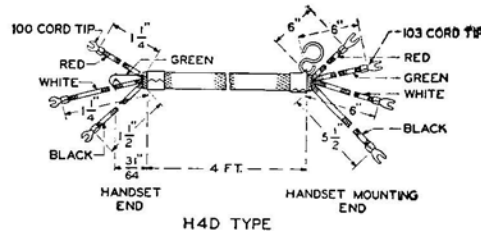

H4D TYPE

Code H4D Type **4 Conductors**

Intended for use with E2B or E2C Type Handsets.

Code	Color	Outer Covering
H4D4	Ivory	Silk
H4D5	Gray	Silk
(a)H4D9	Brown	Cotton
H4D10	Dark Brown	Silk
H4D11	Gold	Silk
(a) Moisture-proofed.		

Deskstand and Transmitter Arm Receiver Cords

The following cords have standard tinsel conductors.

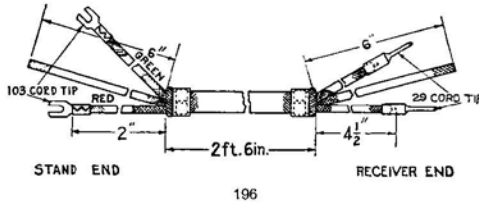

Code 196 2 Conductors

Brown Cotton Covered.

Forms a part of the 468 Cord.

Intended for use with 20CN Deskstand; also 40S, 40BS or 48B Transmitter Arms.

Replaces 49, 227, 294 and 315.

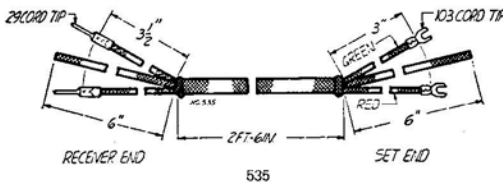

Code 535 2 Conductors

Gray Cotton Covered.

Intended for use with Receivers of such Deskstands as 1040AH, 1120AH and 1140AH; also 40P Transmitter Arm.

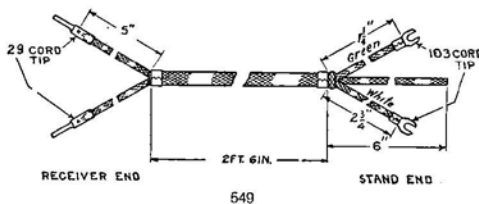

Code 549 2 Conductors

Brown Cotton Covered.

Forms a part of the 450 Cord.

Intended for use with 40CF Deskstand; also 40P Transmitter Arm.

Code 549B

Same as 549 Cord, except the shanks of the 103 Cord Tips are insulated.

Intended for use with 50 Type Deskstands.

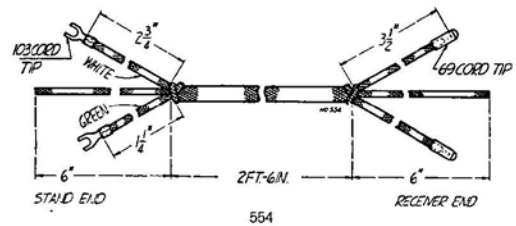

Code 554 (Moisture-proofed) 2 Conductors
Black and Maroon Cotton Covered.

Intended for use with Receivers of 1048 or 1148 Transmitter Arms; also 20AA and 20AB Deskstands with 186 Receivers.

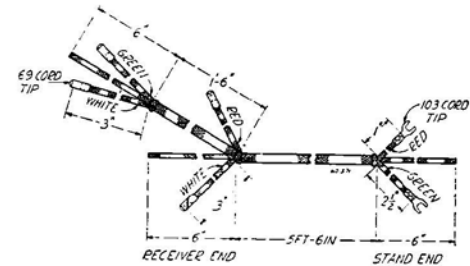

Code 571 2 Conductors

Brown Cotton Covered.

Intended for use with 1010A Headset (Series Connection.)

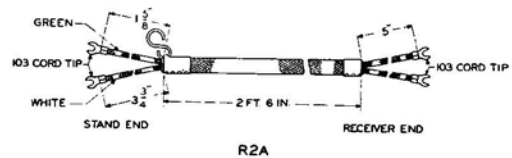

Code R2A 2 Conductors

Brown Cotton Covered.

Intended for use with 51C, 51AL or 51CN Deskstands with 144 Receivers; also 20CC Transmitter Arm.

Replaces 819 and R2G.

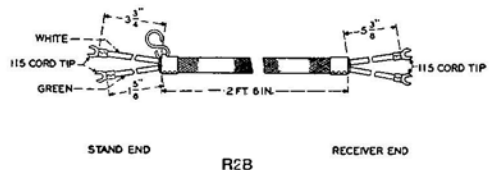

Code R2B 2 Conductors

(Water-proofed Rubber Covered Conductors)

Brown Cotton Covered.

Intended for use in place of the R2A Cord where a water-proofed cord is required.

Deskstand and Transmitter Arm Receiver

Cords—Continued

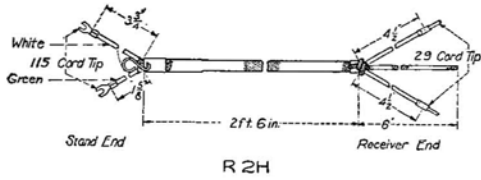

Code R2H **2 Conductors**

(Water-proofed Rubber Covered Conductors)

Brown Cotton Covered.

Intended for use in place of the R2J Cord when a water-proofed cord is required.

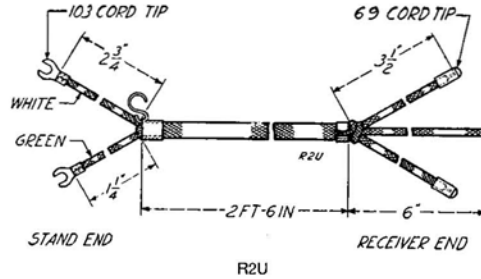

Code R2U (Moisture-proofed) **2 Conductors**

Black and Maroon Cotton Covered.

Intended for use with such Deskstands as 1020AB, 1120AB, 1042AB, 1142AB or 1042BR, and Transmitter Arms 1020C, 1120C, 1020D or 1020E.

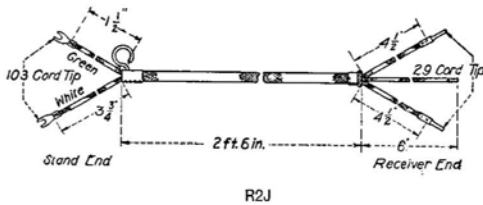

Code R2J **2 Conductors**

Brown Covered Cotton.

Intended for use with 122, 128, 146 or other types of Receivers requiring a 29 Cord Tip.

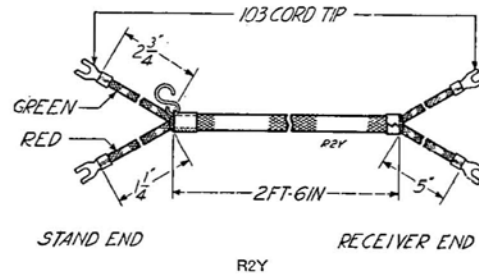

Code R2Y **2 Conductors**

Brown Cotton Covered.

Intended for use with 1040U, 1140CN or 1340CN Deskstands.

Replaces the 412.

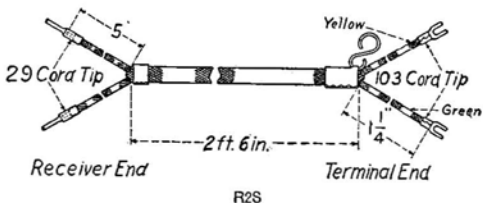

Code R2S **2 Conductors**

Brown Cotton Covered.

Intended for use with 20AH or 40AH Deskstands.

Replaces the 528.

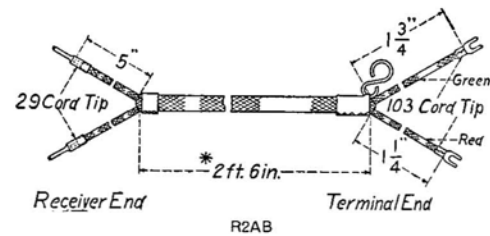

Code R2AB **2 Conductors**

Brown Cotton Covered.

(*) 5 ft. 6 in. cords can be furnished when specified.

Intended for use with 20CJ, 41CJ, 20CN or 40CN Deskstands.

Transmitter Cords for Deskstands and Transmitter Arms

The following cords have standard tinsel conductors.

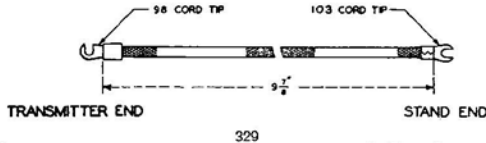

Code 329 1 Conductor
Brown Cotton Covered.
Shank of the 98 Cord Tip insulated.

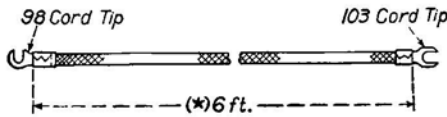

Code 330 1 Conductor
Brown Cotton Covered.
(*) 5 ft. cords can be furnished when specified.
Intended for use on P.B.X. Switchboards.
Shank of the 98 Cord Tip insulated.

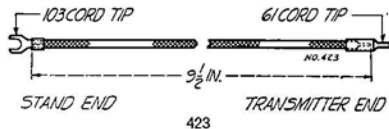

Code 423 (Moisture-proofed) 1 Conductor
Maroon Cotton Covered.
Intended for use with 20 Type Deskstands and non-insulated Transmitters requiring a short Cord Tip; also 48 Type Transmitter Arm.

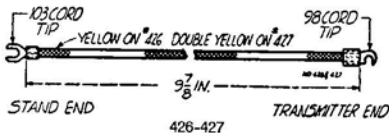

Code 426 (Moisture-proofed) 1 Conductor
Black Cotton Covered.
Intended for use in 20 Type Deskstands; also 20E or 48D Transmitter Arms.
Shank of the 98 Cord Tip insulated.

Code 427 (Moisture-proofed) 1 Conductor
Black Cotton Covered.

Intended for use with 42AB, 42BR, 20AL or 20PC Deskstands; also 20E or 48D Transmitter Arms.
Shank of the 98 Cord Tip insulated.

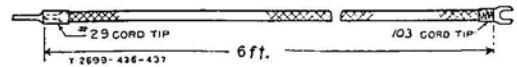

Code 437 1 Conductor
Brown Cotton Covered.

Intended for use with Transmitter Arms or suspended type Transmitters.
Replaces 25 and 27.

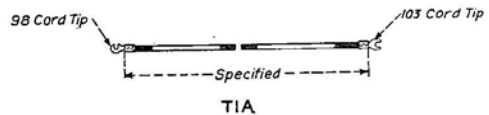

Code T1A (Moisture-proofed) 1 Conductor
Brown Cotton Covered.

Standard Lengths: 6 in., 8 in., 9 7/8 in., and 12 in. Cords will be furnished unless otherwise specified.

Replaces 547.

Recommended in place of 548. Used in 40R, 40U, 40CN, 41CJ or 44BG Deskstands; also 20CC, 40P, 40S, or 48B Transmitter Arms.

Transmitter Arm Connecting Cords

The following cords have standard tinsel conductors.

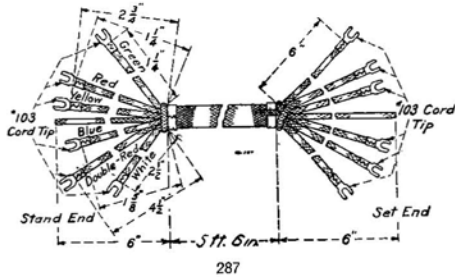

Code 287 (Moisture-proofed) **6 Conductors**
Brown Cotton Covered.
Intended for use with 40S Transmitter Arm.
Forms a part of 468 Cord.
Replaces 339.

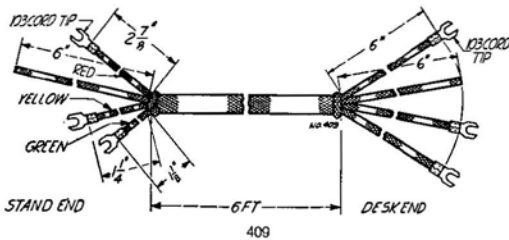

Code 409 (Moisture-proofed) **3 Conductors**
Black and Maroon Cotton Covered.
Intended for use with 48D Transmitter Arm.

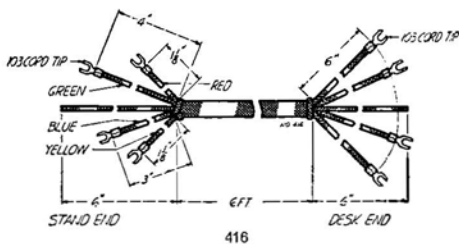

Code 416 (Moisture-proofed) **4 Conductors**
Black and Maroon Cotton Covered.
Intended for use with 20E Transmitter Arm.

Code 450 (Combination)

Consists of:

1-5 1/2 ft. 550 Cord.

1-2 1/2 ft. 549 Cord.

2-9 7/8 in. T1A Cords.

Intended for use with 40P Transmitter Arm.

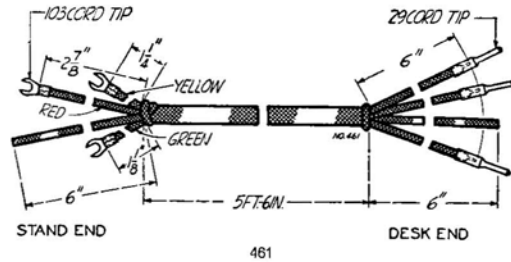

Code 461 (Moisture-proofed) **3 Conductors**
Brown Cotton Covered.
Intended for use with 1020 Type Deskstands.

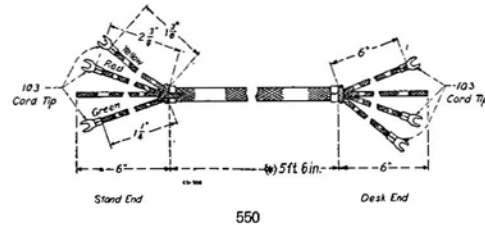

Code 550 (Moisture-proofed) **3 Conductors**
Brown Cotton Covered.

(*) 9 ft., 13 ft., or 25 ft. cords can be furnished when specified.

Forms a part of 450 Cord.

Intended for use with 40P Transmitter Arm.

541 cord recommended when a water-proofed cord is required.

Replaces 180.

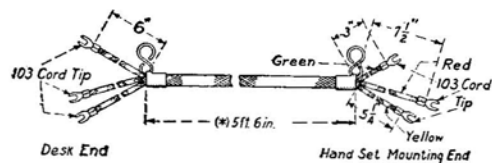

Code D3H Type **3 Conductors**

(*) 9 ft., 13 ft., or 25 ft. cords can be furnished when specified.

Intended for use with 20CC Transmitter Arm.

Code	Color	Outer Covering
D3H4	Ivory	Silk
D3H5	Gray	Silk
(a) D3H9	Brown	Cotton
D3H10	Dark Brown	Silk
D3H11	Gold	Silk

(a) Moisture-proofed.

Replaces D3A.

Wall Telephone Receiver Cords

The following cords have standard tinsel conductors.

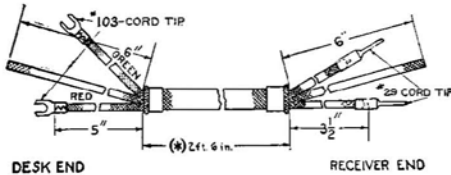

Code 10 2 Conductors
Brown Cotton Covered.
(*) 5 ft. 6 in. cords can be furnished when specified.
Intended for use with exposed Binding Post Receivers.
Replaces 3, 6, 13, 16, 57 and 245.

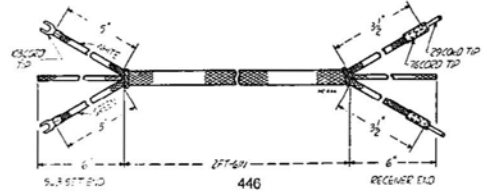

Code 446 (Moisture-proofed) 2 Conductors
Black and Maroon Cotton Covered.
Intended for use with 1293AB or 1293AK Telephone Sets.
Replaces 10 and 92 Cords where a moisture-proofed cord is required.

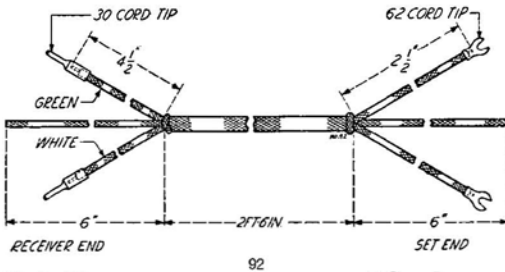

Code 92 2 Conductors
Brown Cotton Covered.
Intended for use with exposed Binding Post Receivers.

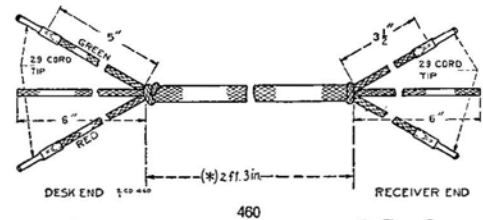

Code 460 2 Conductors
Brown Cotton Covered.
(*) 5 ft. 3 in. cords can be furnished when specified.
Intended for use with exposed Binding Post Receivers.
Replaces 454.

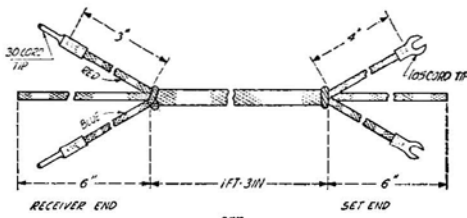

Code 357 2 Conductors
(Water-proofed Rubber Covered Conductors)
Black Cotton Covered.
Intended for use with Receiver of 1320A Telephone Set.

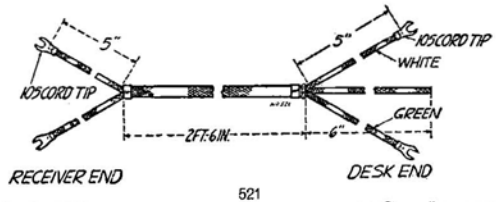

Code 521 2 Conductors
Brown Cotton Covered.
Intended for use with concealed Binding Post Receivers.
Replaces 419.

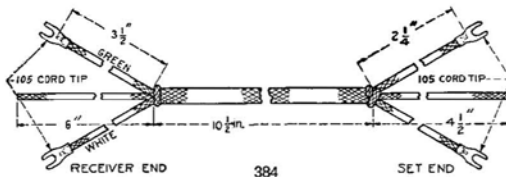

Code 384 2 Conductors
(Water-proofed Rubber Covered Conductors)
Black Cotton Covered.
Intended for use with 1336 or 1337 Telephone Sets.
Replaces 311.

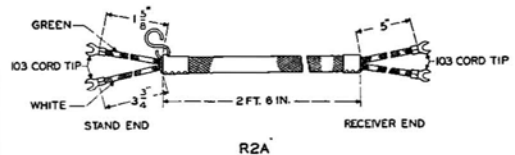

Code R2A 2 Conductors
Brown Cotton Covered.
Intended for use with 51C, 51AL or 51CN Deskstands with 144 Receivers; also 20CC Transmitter Arm.
Replaces 819 and R2G.

Wall Telephone Receiver Cords—Continued

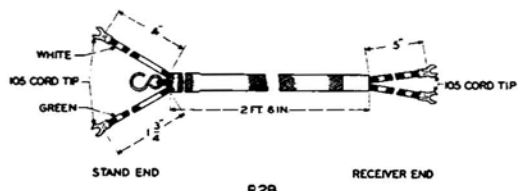

Code R2B (Water-proofed Rubber Covered Conductors) Black Cotton Covered. Intended for use in place of the R2A Cord where a water-proofed cord is required. **2 Conductors**



Code R2AD (Water-proofed) Black Cotton Covered. Conductors are of rubber covered 18A.W.G. stranded copper wire. Intended for use with 558 Receiver in the 1536E (Mine) Telephone Set. **2 Conductors**

Wall Telephone Transmitter Cords

The following cords have standard tinsel conductors.

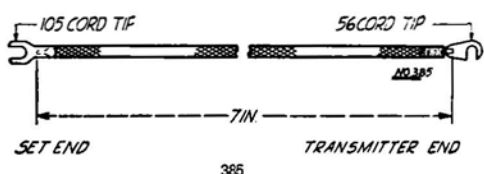

Code 385 (Water-proofed) Rubber and Black Cotton Covered. Intended for use with 601A Transmitter in the 1336F and 1336H Telephone Sets. **1 Conductor**

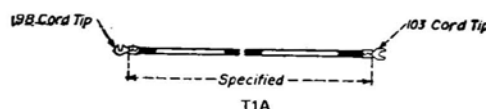

Code T1A (Moisture-proofed) Brown Cotton Covered. Standard Lengths: 6 in., 8 in., 9 7/8 in., and 12 in. 9 7/8 in. Cords will be furnished unless otherwise specified. Intended for use with insulated transmitters. Replaces 547. Recommended in place of 548. **1 Conductor**

Handset Transmitter and Receiver Cords

The following cords have standard tinsel conductors.

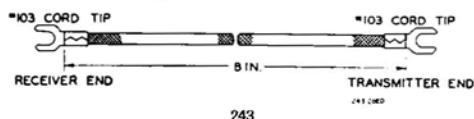

Code 243 Brown Cotton Covered. Intended for use with 1001A Handset. **1 Conductor**

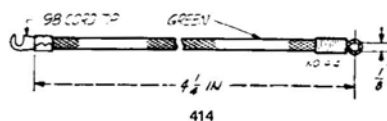

Code 414 Brown Cotton Covered. Intended for use with 1002AC Handset. **1 Conductor**

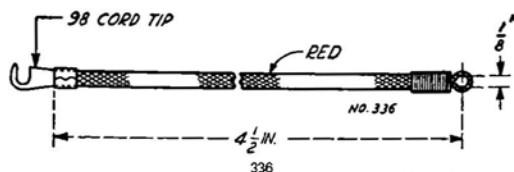

Code 336 Brown Cotton Covered. Intended for use with 1002C, 1002D and 1002E Handsets. **1 Conductor**

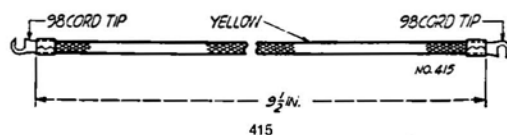

Code 415 Brown Cotton Covered. Intended for use with 1002AC Handset. **1 Conductor**

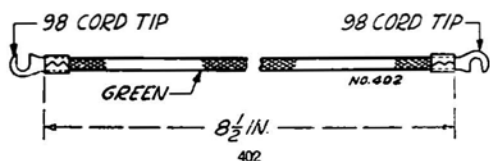

Code 402 Brown Cotton Covered. Intended for use with 1002D and 1002E Handsets. **1 Conductor**

Miscellaneous Test Set and Telephone Cords

The following cords have standard tinsel conductors unless otherwise specified.

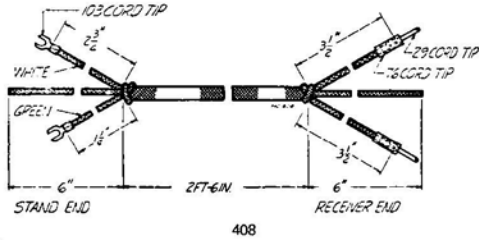

Code 408 (Moisture-proofed) **2 Conductors**
 Black and Maroon Cotton Covered.
 Intended for use in Headband Receivers.

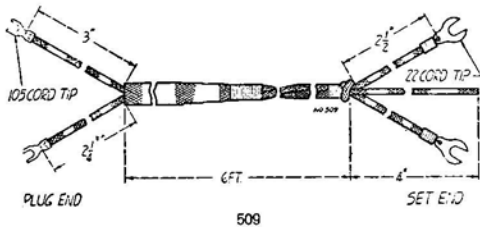

Code 509 **2 Conductors**
 (Water-proofed Rubber Covered Conductors)
 Black Glazed Cotton Covered.
 Intended for use with portable Telephone Sets such as 1330 or 1331 type.
 Arranged for 146 Plug.

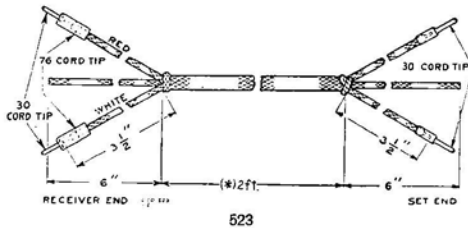

Code 523 (Water-proofed) **2 Conductors**
 Black Cotton Covered.
 (*) 2 1/2 ft. cords can be furnished when specified.
 Linemen's Receiver Cord, intended for use with 6 and 17 Type Test Sets.
 Replaces 15 and 522.

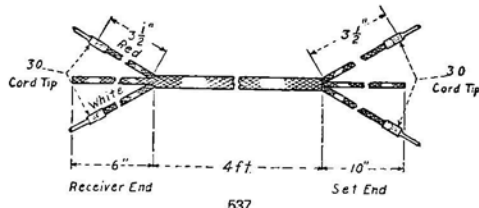

Code 537 **2 Conductors**
 (Water-proofed Rubber Covered Conductors)
 Black Cotton Covered.
 Receiver Cord intended for use with 19A Test Set.

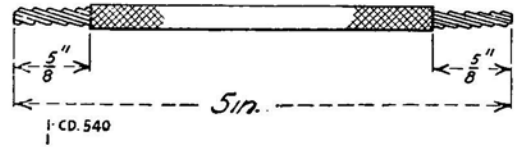

Code 540 **1 Conductor**
 Brown Cotton Covered.
 Stranded Copper Conductors.
 Intended to connect dry cells equipped with string or screw terminals.
 Replaces 338.

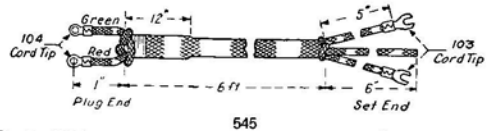

Code 545 **2 Conductors**
 Brown Cotton Covered.
 Intended for use with portable Subscriber Sets.
 Arranged for 148 Plug.

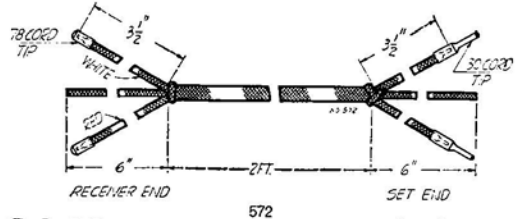

Code 572 **2 Conductors**
 (Water-proofed Rubber Covered Conductors)
 Black Cotton Covered.
 Intended for use with 515 Receiver and 1017 Type Test Set.

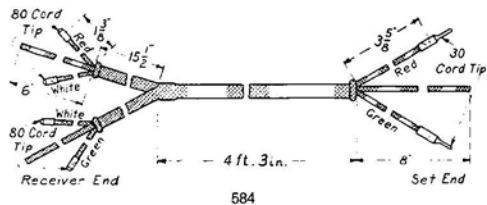

Code 584 **2 Conductors**
 (Water-proofed Rubber Covered Conductors)
 Black Cotton Covered.
 Receiver Cord arranged to connect 2 No. 528 Receivers in series.
 Intended for use with 19 Type Test Sets.

Miscellaneous Test Set and Telephone Cords—Cont'd

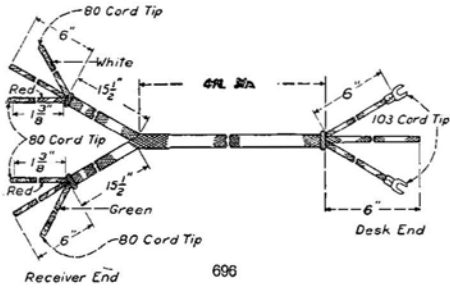

Code 696 2 Conductors
Brown Cotton Covered.
Receiver Cord with a third conductor introduced in receiver end to permit of connecting two receivers in series.
Arranged for 528 Type Receivers.

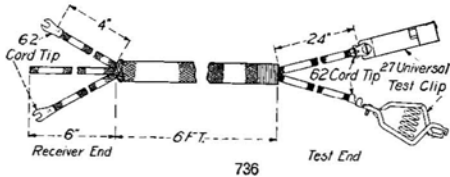

Code 736 2 Conductors
(Water-proofed Rubber Covered Conductors)
Beeswaxed Black Cotton Covered.
Intended for use with 17 Type Test Set on open wire lines.
Equipped with Test Clips.

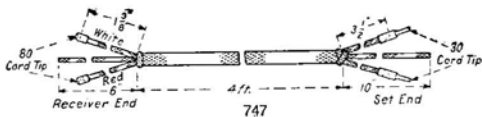

Code 747 2 Conductors
(Water-proofed Rubber Covered Conductors)
Black Cotton Covered.
Intended for use with 528 Receiver and 19C Test Set.
Arranged for 186 Plug.

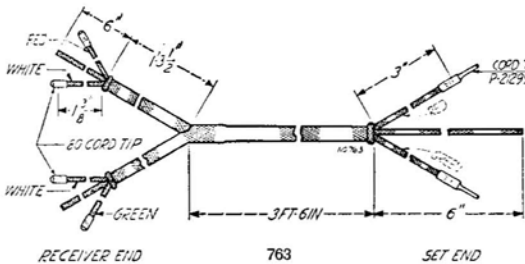

Code 763 2 Conductors
Black Cotton Covered.
Intended for use with 1002C or 1004A Headsets.

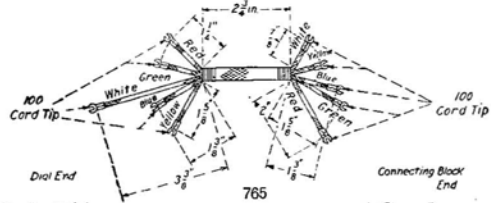

Code 765 5 Conductors
Brown Cotton Covered.
Forms a part of 6000A, 6000B, 6000C or 6000D Dial Mountings.

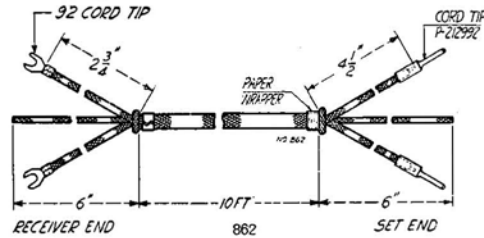

Code 862 2 Conductors
Brown Cotton Covered.
Intended for use with 560AW Receiver.

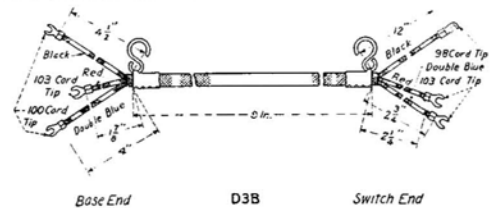

Code D3B 3 Conductors
Brown Cotton Covered.
Intended for connecting between switch and base in 51AL, 51CM, 51CN or 52AB Deskstands.
Replaces 816.



Code R2AJ 2 Conductors
Water-proofed Rubber Covered Cord with rubber covered No. 18 gauge stranded copper wire conductors.
Receiver Cord for use with 1526B Telephone Set.

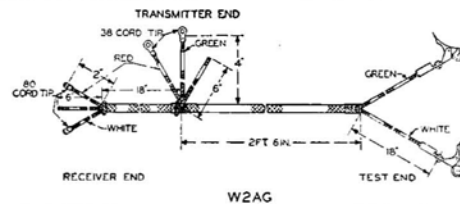

Code W2AG 2 Conductors
(Water-proofed Rubber Covered Conductors)
Black Cotton Covered.
Intended for use with 528 Receiver for testing lines at connecting boxes.
Equipped with test clips.
Recommended in place of 744 Cord.

CORD ACCESSORIES

Cord Fasteners

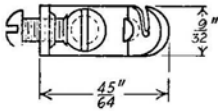

Code No.
9

Description

This cord fastener is made of tinned brass. The screw end is spun over. Used on cord shelves with all types of switchboard cords.

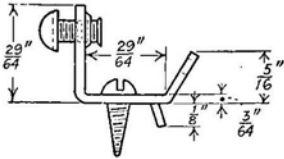

No. 9 Cord Fastener

Cord Hooks



No. 3 Cord Hook



No. 5



No. 7A, 3 per strip

Code No.

Description

- 3 Bright iron wire screw hook, overall length 1 5/8".
- 5 Brass: overall length 1 1/16".
- 6 Brass screw hook similar to No. 5 except that the hook end is bent out.

NO. 7 TYPE

The No. 7 Type Cord Hook is designed for placement on the rear edge of cord shelves and consists of a flat brass strip 1/16" thick x 3/4" wide. The hooks are punched out and formed on various spacings as listed below.

The mounting holes are located 3/16" from the top and bottom edge alternately at convenient distances from each other according to the length of the strip. When only two hooks per strip are ordered the mounting holes are located one above the other. Furnished complete with mounting screws.

These cord hooks are furnished with any number of hooks per strip from 2 to 32 and the number of hooks per strip desired must be specified in the order.

Code No.	Spacing of Hooks (Inches)	Maximum Number of Hooks per Strip
7A	2 7/32	14
7C	3/4	16

To Obtain Overall Length in Inches

- Multiply number of hooks per strip by spacing and add 1/2 inch.
- Multiply number of hooks per strip by spacing and add 1/2 inch.

NO. 9 TYPE

This is a black finished metal hook used for holding patching cords and operator's telephone set when not in use. Overall dimensions 3 1/2 x 3 13/32 x 3/4 inches.

CORD PULLEYS

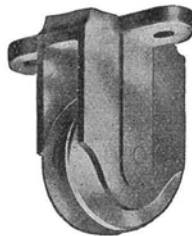

No. 106

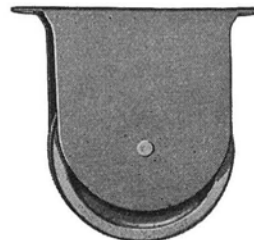

No. 112

Note. Both types listed may be used for switchboard or telephone cords.

Code No.

Description

- 106 Brass frame supporting a brass wheel 9/32" wide. The wheel rim surface is a sharp groove. The mounting lugs are at the side of the frame. Overall dimensions 1 3/16 x 7/8 x 1 1/2".
- 112 Steel frame supporting a brass wheel 1/4" wide. The rim of the wheel is a round groove. The steel frame is galvanized and the mounting lugs are at the ends. Overall dimensions 2 5/16 x 2 3/32 x 2 5/64".

CORD TIPS

All cord tips are made of brass

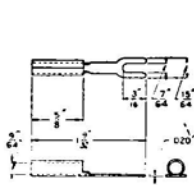

No. 8
Tinned

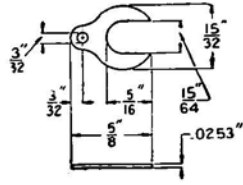

No. 22
Tinned

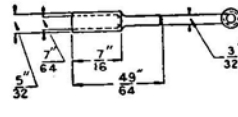

No. 29
Nickel Plated

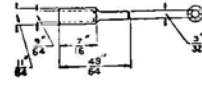

No. 30
Nickel Plated

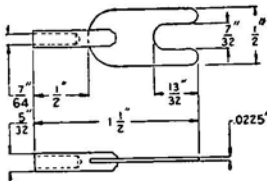

No. 35
Nickel Plated

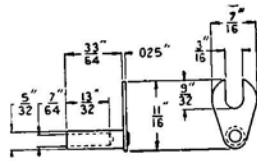

No. 37
Nickel Plated

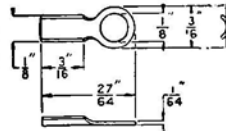

No. 38
Tinned

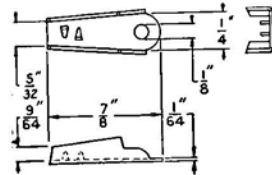

No. 45
Brass

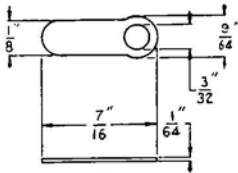

No. 47
Tinned

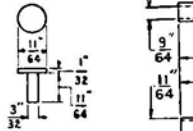

No. 55
Tinned

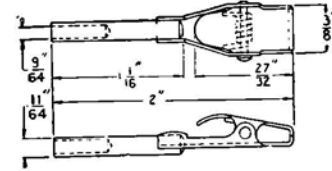

No. 59
Nickel Plated

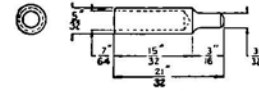

No. 61
Nickel Plated

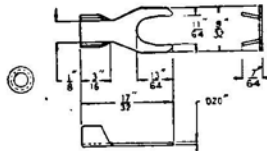

No. 62
Tinned

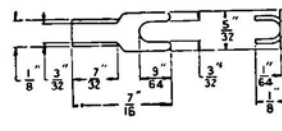

No. 70
Tinned

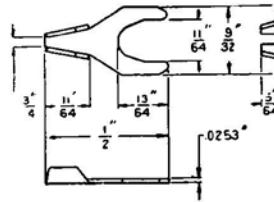

No. 72
Tinned

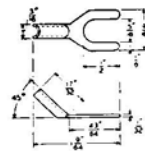

No. 74
Tinned

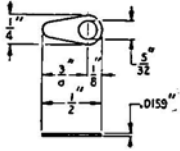

No. 75
Tinned



No. 76
Rubber



No. 78
Nickel Plated

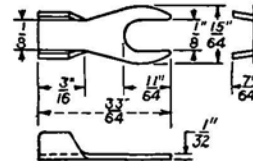

No. 79
Tinned

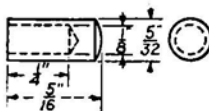

No. 80
Nickel Plated

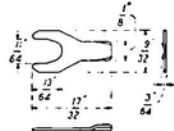

No. 85
Tinned



No. 86
Tinned

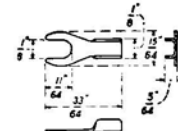

No. 87
Tinned

CORD TIPS—Continued

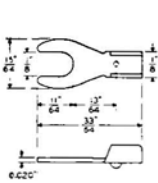
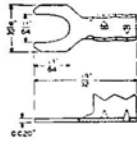
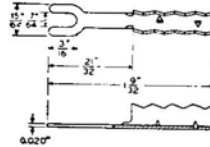
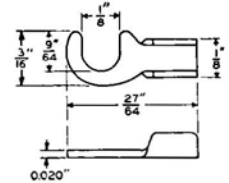
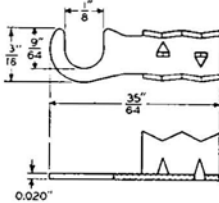
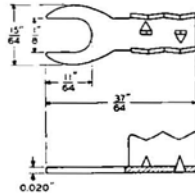
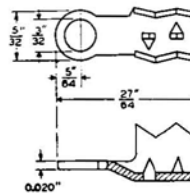
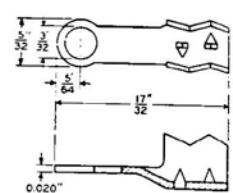
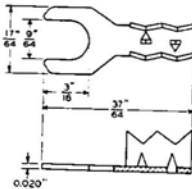
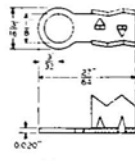
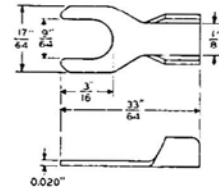
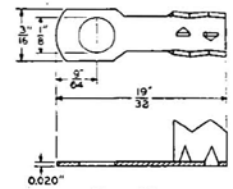
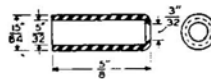
No. 91
TinnedNo. 92
Nickel FinishedNo. 93
Nickel FinishedNo. 97
TinnedNo. 98
Nickel FinishedNo. 100
Nickel FinishedNo. 101
Nickel FinishedNo. 102
Nickel FinishedNo. 103
Nickel FinishedNo. 104
Nickel FinishedNo. 105
TinnedNo. 109
Nickel FinishedNo. 106
Rubber

Cord Tips

Code
No.

- 8 Tinned. For use on switchboard cords in connection with Nos. 8 and 9 cord fasteners. Replaces No. 42.
- 22 Flat, tinned for fastening under binding post or screw. Slotted for No. 12 screw. Replaces No. 43.
- 29 Nickel plated. Ordinarily used on silk covered cords in connection with drilled binding posts. Replaces No. 10. Recommended in place of No. 31.
- 30 Nickel plated. Ordinarily used on worsted or cotton covered cords in connection with drilled binding posts. Replaces Nos. 13 and 20. Recommended in place of No. 31.
- 35 Nickel plated. For use in connection with bracket transmitters. Slotted for No. 12 screw.
- 37 Nickel plated, nickel silver tip with nickel plated brass shank; for use in connection with bracket transmitters. Slotted for No. 8 screw. Replaces No. 25.
- 38 Tinned, eyelet tip; for use on plug end of switchboard cords. Replaces No. 41.
- 45 Eyelet tip; for use on stay cord end of switchboard cords.

Code
No.

- 47 Tinned, eyelet tip; for use on plug end of switchboard cords. Replaces Nos. 23 and 27.
- 55 Tinned; for use with transmitter cords.
- 59 Nickel plated, brass spring tip with one-piece shank.
- 61 Nickel plated; for use with drilled binding posts where a short tip is required. Replaces No. 60.
- 62 Tinned. Slot beveled to admit either a No. 6 or No. 8 screw. Replaces Nos. 1, 53, 54 and 58.
- 70 Tinned; for use in connection with battery gauges.
- 72 Tinned; for fastening under binding post or screw. Ordinarily used on transposition leads in subscriber sets.
- 74 Open end tinned, with a soldering lug of semi-circular section bent up at an angle of 45 degrees. Intended for use as a connection between the ends of the bridle wires and the upper ends of the No. 51A Fuse, both of which are a part of the No. 93A Protector.
- 75 Tinned; for fastening under No. 116 plug connecting screw.
- 76 Semi-hard rubber sleeve intended to cover the exposed portion of the No. 30 cord tip.

CORD TIPS—Continued

<p>Code No. 78 Nickel plated; for drilled binding posts. Used on such cords as the No. 572. 79 Tinned; for fastening under binding post or screw. 80 Nickel plated; for use with high efficiency receivers. 85 Tinned; for fastening under binding post or screw. Slotted for Nos. 6 or 8 screw. 86 Tinned; for fastening under binding post or screw. Slotted for Nos. 6 or 8 screw. 87 Tinned; for fastening under binding post or screw. Slotted for No. 4 screw. 91 Tinned. Slotted for No. 4 screw. 92 Solderless, nickel finished; having two tangs for making contact with conductors on cords having tinsel conductors. Slotted for Nos. 6 or 8 screw. 93 Solderless, nickel finished; having two tangs for making contact with conductors on switchboard cords having tinsel conductors. Used in connection with Nos. 8 and 9 cord fasteners. 97 Tinned; for use on transmitter and hand set cords. Slotted for No. 4 screw. Partially replaces No. 56.</p>	<p>Code No. 98 Solderless, nickel-finished; having two tangs for making contact with tinsel conductor. For use on transmitter cords. Slotted for No. 4 screw. Partially replaces No. 56. 100 Solderless, nickel-finished; having two tangs for making contact with tinsel conductor. For use on hand set cords. Slotted for No. 4 screw. 101 Solderless nickel-finished; having two tangs for making contact with tinsel conductor. 102 For use on ring and tip conductors respectively of cords arranged for Nos. 109 and 110 type plugs. 103 Solderless nickel-finished; having two tangs for making contact with tinsel conductors. Slotted for No. 6 screw. 104 Solderless nickel-finished; having two tangs for making contact with tinsel conductor. For use on cords arranged for Nos. 47 and 137 type plugs. 105 Tinned; for use on station cords. Slotted for No. 6 screw. 106 Semi-hard rubber sleeve intended to cover the exposed portion of the No. 29 cord tip. 109 Solderless nickel-finished; having two tangs for making contact with tinsel conductor.</p>
---	--

CORD WEIGHTS

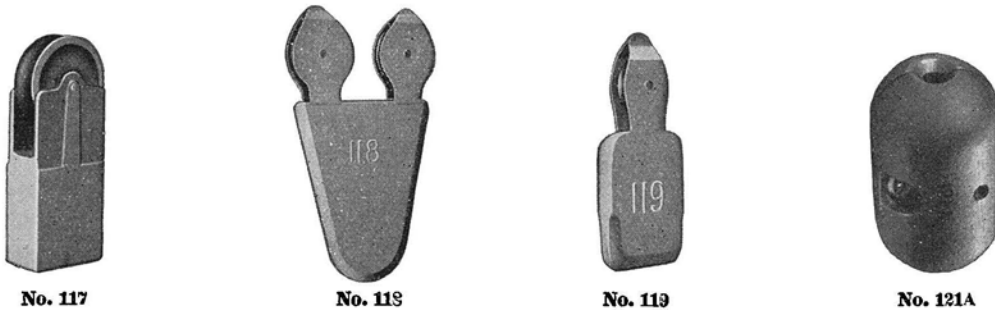

Code No.	Description	Use
117	18 oz. single pulley brass weight. Pulley wheel 1 1/2" wide. Overall dimensions 5/8 x 2 5/16 x 4 inches.	General
118	29 1/2 oz. double pulley iron weight, galvanized finish. Pulley wheel 1/4" wide; wheel space 2 3/4" centers. Overall dimensions 1 3/32 x 4 1/16 x 7 37/64 inches.	In switchboards when double length cord is required.
119	9 1/2 oz. single pulley, cast iron weight, galvanized finish. Pulley wheel 1/4" wide. Overall dimensions 1/16 x 2 3/16 x 4 1/16 inches. Replaces the No. 116 Cord Weight.	Used in Nos. 1240, 1962, 1948 and other types of switchboards.
120	12 1/2 oz. single pulley, cast iron weight. Pulley wheel 1/4 inch. Overall dimensions 1/16 x 2 5/8 x 4 27/32 inches.	Same as No. 119.
121A	325 grams, nickel finish weight. Overall dimensions 1 1/4 x 2 3/8 inches.	With jack testing plugs and gauges to clamp the cord near the heel of plug or gauge.

DESIGNATION STRIPS



Wood Type with Metal Face



Wood Type with Rubber Face



Wood Type with Celluloid Face



Metal Face

WOODEN TYPE WITH METAL FACE

These consist of a wooden mounting strip with a black finished No. 8 Type Designation Strip attached to the face and are for use in designating outgoing trunk jacks, etc.

Code No.	Width of Face, Ins.	Length		Used with Jack Mountings
		Overall	Face	
1C	$\frac{7}{16}$	$9\frac{13}{16}$	$9\frac{3}{16}$	Nos. 1, 2, 3, 21, 22, 34, 36, 46, 47, 62, 63, 75, 77, 84, 85
1G*	$\frac{1}{2}$			
6F	$\frac{3}{8}$	$8\frac{3}{8}$	$7\frac{23}{32}$	Nos. 18, 19, 20, 83, 102, 113
10E	$\frac{1}{2}$			
51A	1	$11\frac{9}{16}$	$11\frac{3}{16}$	Nos. 4, 5, 6, 7, 8, 35, 37, 45, 89, 115
62A	1			
				Nos. 108, 109, 110, 112
				Nos. 1, 2, 3, 21, 22, 34, 46, 47, 62, 63, 75, 77, 84, 85, 114, 141, 142, 143, 144

* Has a $\frac{1}{16}$ " Holly Strip mounted on top. The width of face as given above includes the holly strip.

WOODEN TYPE WITH CELLULOID FACE

These consist of wooden mounting strips with transparent celluloid face strips which are intended to cover a strip of printed figures.

Code No.	Width of Face, Ins.	Length		Used with Jack Mountings
		Overall	Face	
7A	$\frac{7}{16}$	$9\frac{13}{16}$	$9\frac{3}{16}$	Nos. 1, 2, 3, 21, 22, 34, 36, 46, 47, 62, 63, 75, 77, 84, 85
7B	$\frac{1}{4}$			
24A	$\frac{1}{16}$	$11\frac{1}{8}$	$10\frac{1}{2}$	Nos. 6, 7, 8, 35, 37, 45, 89, 115, 116
55A	$\frac{7}{16}$			
55B*	$\frac{1}{2}$	$11\frac{9}{16}$	$11\frac{3}{16}$	Nos. 108, 109, 110, 112

* Has a $\frac{1}{16}$ " Holly Strip mounted on top. The width of face as given above includes the holly strip.

WOODEN TYPE WITH RUBBER FACE

These consist of a wooden mounting strip with a hard rubber face which is milled and drilled for 20 Number Plates.

Code No.	Width	Overall	Face	Used with Jack Mountings	Number Plates
14A	$\frac{3}{8}$	$8\frac{3}{8}$	$7\frac{23}{32}$	Nos. 18, 19, 20, 83, 102, 113, 155	Nos. 6, 30 or 60
50A	$\frac{7}{16}$	$11\frac{9}{16}$	$11\frac{3}{16}$	Nos. 108, 109, 110, 112	Nos. 4, 31, 32 or 59

METAL TYPE

These consist of a black finish metal retaining strip. The No. 8 also has a transparent celluloid strip for protecting a strip of printed figures. Mounting screws are furnished.

The No. 90-A is intended to mount on Nos. 184 and 185 Jack Mountings and No. 262 Lamp Socket Mountings and is arranged to accommodate a designation card for each pair of jacks or lamps.

Code No.	Width, Ins.	Length
8G	$\frac{7}{16}$	Specified
8H	$\frac{3}{8}$	Specified
8K	$\frac{5}{8}$	$6\frac{1}{8}$ "
8L	$\frac{7}{16}$	Specified
8M	$\frac{3}{8}$	Specified
8P	$\frac{7}{16}$	$22\frac{13}{16}$ "
8R	$\frac{7}{16}$	$27\frac{3}{16}$ "
8U	$\frac{5}{8}$	Specified
43B	$\frac{39}{64}$	$1\frac{1}{2}$ "
43C	$\frac{39}{64}$	$1\frac{1}{4}$ "
43D	$\frac{3}{4}$	$1\frac{1}{4}$ "
90A	$\frac{7}{16}$	$15\frac{1}{16}$ "

DESK STANDS



No. 1040AL Deskstand

These desk stands are in the simplest form that desk stands have ever been produced. There are but three principal units exclusive of the transmitter and receiver, namely, the terminal plate and switchhook assembly, the base and stem assembly, and the base plate assembly. The switchhook lever acts directly upon the main spring of the switch, no intermediate parts being interposed to increase the possibility of trouble. The entire terminal plate and switchhook assembly may be withdrawn from the stem and base assembly for inspection without disconnecting the cords or interrupting the service in any way. This is accomplished by merely removing one screw from the bottom of the base plate.

The bottom and edges of the base plate are covered with felt.

The contact springs are nickel silver backed with stop springs.

All current carrying parts are insulated from the frame.

Because of the simplicity of design and the high quality of the apparatus and material used the cost of maintaining Western Electric desk stands is practically nothing.

Central and Local Battery

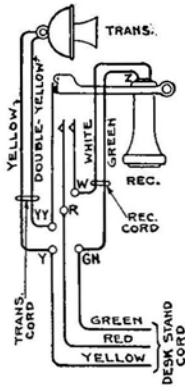

No. 1040AL



*No. 1051AL

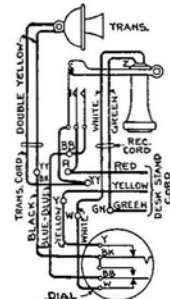

No. 1051AL

Code No.	Consist of					
	Deskstand	Transmitter	Receiver	Rec.	Cords Trans.	Deskstand
1040-AL	40-AL	323	144	450	Combination	550
				549	2 T1A	550
				2½ ft. long	9⅞ in. long	5½ ft. long

Use
Standard deskstand for central battery and local battery service.

Machine Switching

Code No.	Consists of						*Dial
	Deskstand	Transmitter	Receiver	Rec.	Cords Trans.	Deskstand	
1051-AL	51-AL	323	144	R2A	T1A	1 D3A	As Specified
				2½ ft. long	9⅞ in. long	5½ ft. long	
						1 D3B 9 in. long	

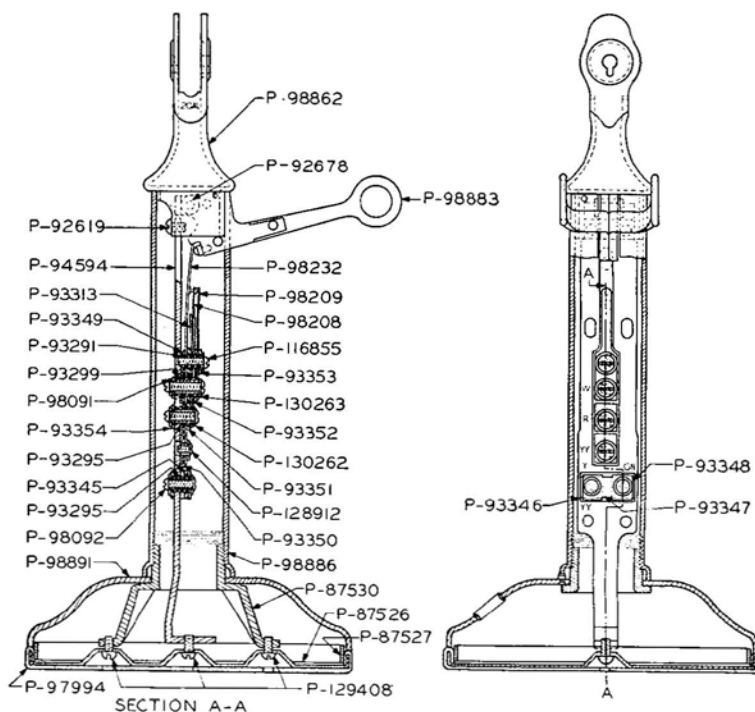
DESK STANDS—Continued**Replacement Parts**

NO. 20-AL DESK STAND

Piece No.	Part No.	Req.	Material	Name	Piece No.	Part No.	Req.	Material	Name
P87526	1	1	Steel	Base Plate	P93353	1	Rubber	Washer	
P87527	1	1	Steel	Clamp	P93354	4	Rubber	Washer	
P87530	1	1	Steel	Clamping Nut	P129408	3	Steel	R.H.M. Screw	
P92619	2	2	Steel	R.H.M. Screw	P94594	1	Steel	Terminal Plate	
P92678	1	1	Steel	Pivot	P97994	1	Felt	Cushion	
P116855	1	1	Brass	R.H.M. Screw	P98091	5	Steel	Washer	
P93291	1	1	Rubber	Bushing	P98092	4	Steel	R.H.M. Screw	
P93295	3	3	Rubber	Bushing	*P98862	1	Brass	Lug Holder	
P93299	1	1	Rubber	Bushing	*P98886	1	Brass	Handle	
P93313	1	1	Brass	Stop Spring	P128912	1	Brass	But. H.M. Screw	
P93345	1	1	Steel	Distance Piece	P98208	1		Contact Spring Assembly	
P93346	1	1	Rubber	Insulator	P98209	1		Contact Spring Assembly	
P93347	1	1	Rubber	Insulator	P98232	1		Contact Spring Assembly	
P93348	2	2	Brass	Clamp	*P98883	1		Hook Assembly	
P93349	1	1	Steel	Distance Piece	*P98891	1		Base Assembly	
P93350	1	1	Rubber	Insulator	P130262	3		Screw Bushing Assembly	
P93351	1	1	Rubber	Insulator	P130263	1		Screw Bushing Assembly	
P93352	1	1	Rubber	Insulator					

No. 40AL Desk Stand

* The parts for the 40AL Desk Stand are the same as the 20AL except for the following:

Lug Holder	P97337	Hook Assembly	P97343
Handle	P97363	Base Assembly	P97351

DESK STANDS

Replacement Parts—Continued

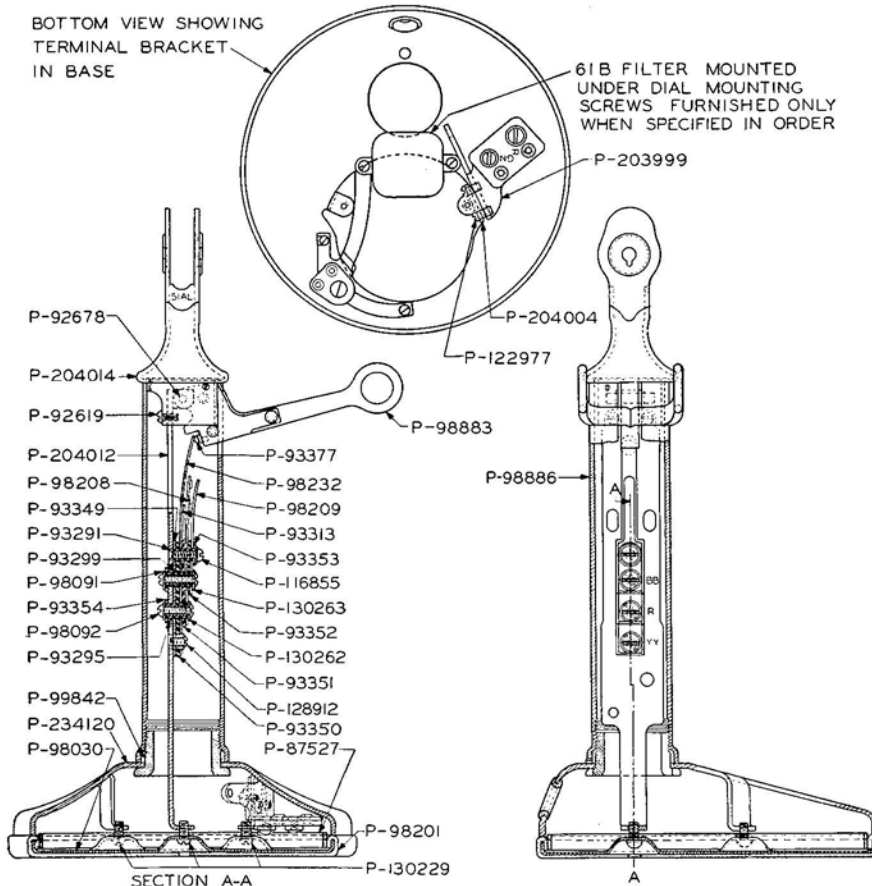

NO 51-AL DESK STAND

Piece Part No.	No. Req.	Material	Name	Piece Part No.	No. Req.	Material	Name
P87527	1	Steel	Clamp	P99842	1	Steel	Clamping Nut
P92619	2	Steel	R.H.M. Screw	P122977	2	Steel	R.H.M. Screw
P92678	1	Steel	Pivot	P128912	1	Brass	But. H.M. Screw
P116855	1	Brass	R.H.M. Screw	P130229	3	Steel	R.H.M. Screw
P93291	1	Rubber	Bushing	P204004	1	Steel	Clamping Plate
P93295	1	Rubber	Bushing	P204012	1	Steel	Terminal Plate
P93299	1	Rubber	Bushing	P204014	1	Brass	Lug Holder
P93313	1	Brass	Stop Spring		1		4H Type Dial (furnished when specified)
P93349	1	Steel	Distance Piece	P290076	1		Strap
P93350	1	Rubber	Insulator	P98208	1		Contact Spring Assembly
P93351	1	Rubber	Insulator	P98209	1		Contact Spring Assembly
P93352	1	Rubber	Insulator	P98232	1		Contact Spring Assembly
P93353	1	Rubber	Washer	P98883	1		Hook Assembly
P93354	2	Rubber	Washer	P234120	1		Base Assembly
P93377	1	Rubber	Hook Stop	P130262	1		Screw Bushing Assembly
P98030	1	Steel	Base Plate	P130263	1		Screw Bushing Assembly
P98091	3	Steel	Washer	P203999	1		Left Terminal Bracket Assembly
P98092	2	Steel	R.H.M. Screw				
P98201	1	Felt	Cushion				
P98886	1	Brass	Handle				

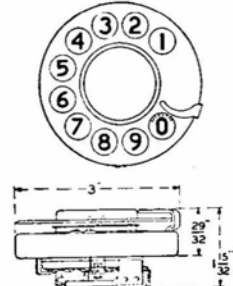
DIALS—MACHINE SWITCHING**4H Type Dials—Front and Rear Views****4HA**

Western Electric dials are reliable in operation and are designed to operate between very close speed limits.

These dials are designed to mount on Western Electric machine switching, desk stands, handset mountings, and wall type telephones; also in Western Electric dial mountings; also for switchmen's desks, trouble desks and local test desks in manual offices for connecting with dial offices.

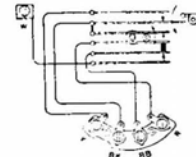
**4 HA****4H TYPE DIALS**

The 4H Type Dials are intended for use at subscriber stations, Private Branch Exchange switchboards and with repairmen's handsets.

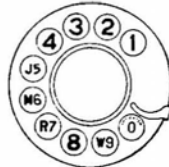
**4HB****4HD****4HE****4HH**

Mounts on C1, D1, E4 or similar type handset mountings, No. 51 or similar type desk stands, No. 553 or similar type subscriber sets or on repairmen's handset handles.

Also mounts on a 30A or similar type Dial Mounting by means of a No. 52B Dial Adapter.

The 4H Type Dial is provided with a finger wheel which when rotated causes a pair of contacts to make and break, thus permitting current impulses to flow over the line and operate the selecting mechanism and also causes another set of contacts to make the necessary changes in the station circuit in which the Dial is used.

The 4H Type Dial is equipped with No. 149 Type Number Plates as indicated below. These Number Plates may be removed for maintenance purposes. The following 4 Type Dials differ only in the Number Plates and colors as indicated.

Code No.	Color	Number Plate	Color of Characters		Replaces No.
			Numerals	Letters	
4HA-3	Black	149A	Black	Black	2HA-3 & 2AA
4HA-4	Ivory	149A	Black	Black	2HA-4
4HA-5	Gray	149A	Black	Black	2HA-5
4HA-6	Old Brass	149A	Black	Black	2HA-6
4HA-7	Statuary Bronze	149A	Black	Black	2HA-7

DIALS—MACHINE SWITCHING—Continued

Code No.	Color	Number Plate	Color of Characters		Replaces No
			Numerals	Letters	
4HA-8	Oxidized Silver	149A	Black	Black	2HA-8
4HA-11	Medium Gold	149A	Black	Black	—
4HA-12	Dark Gold	149A	Black	Black	—
4HB-3	Black	149B	Red	Black	2HB-3 & 2AB
4HB-4	Ivory	149B	Red	Black	2HB-4
4HB-5	Gray	149B	Red	Black	2HB-5
4HB-6	Old Brass	149B	Red	Black	2HB-6
4HB-7	Statuary Bronze	149B	Red	Black	2HB-7
4HB-8	Oxidized Silver	149B	Red	Black	2HB-8
4HB-11	Medium Gold	149B	Red	Black	—
4HB-12	Dark Gold	149B	Red	Black	—
4HD-3	Black	149D	Black	Black	2HD & 2AD
4HE-3	Black	149E	Black	(*)	2HE-3 & 2AE
4HE-4	Ivory	149E	Black	(*)	2HE-4
4HE-5	Gray	149E	Black	(*)	2HE-5
4HE-6	Old Brass	149E	Black	(*)	2HE-6
4HE-7	Statuary Bronze	149E	Black	(*)	2HE-7
4HE-8	Oxidized Silver	149E	Black	(*)	2HE-8
4HE-11	Medium Gold	149E	Black	(*)	—
4HE-12	Dark Gold	149E	Black	(*)	—
4HH-3	Black	149H	No Characters		2AH

(*) Word "Operator" is in black, other letters are in red.

4E TYPE DIAL

The 4E Type Dials are intended for use on switchmen's desks, trouble desks and local test desks in manual offices for connecting with dial offices.

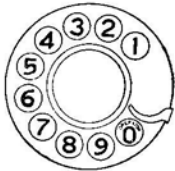

4EA

Code No.	Number Plate	Color of Characters		Replaces No.
		Numerals	Letters	
4EA	149A	Black	Black	2EA
4EB	149B	Red	Black	2EB
4ED	149D	Black	Black	2ED
4EE	149E	Black	(*)	2EE

(*) Word "Operator" is in black, other letters are in red.

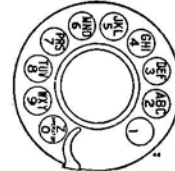

4EB

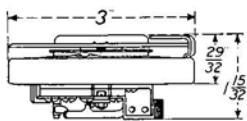

4E Type

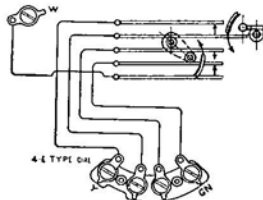

4E Type



4ED

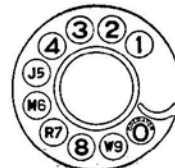

4EE

DIAL ADAPTERS

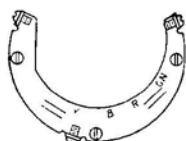

52B

Code No.
52B

Use and Description

For use with 2E or 4E Type Dials. For mounting Dials on Nos. 30, 32, 6000 or similar type Dial Mountings. Consists of black finished plates provided with machine screws for attaching Adapter to Dial and Adapter to Dial Mounting.

52C

For use with 2A or 4H Type Dials. For mounting Dials on Nos. 30, 32, 37, 39, 6000 or similar type Dial Mountings. Otherwise same as 52B.

DIAL MOUNTINGS

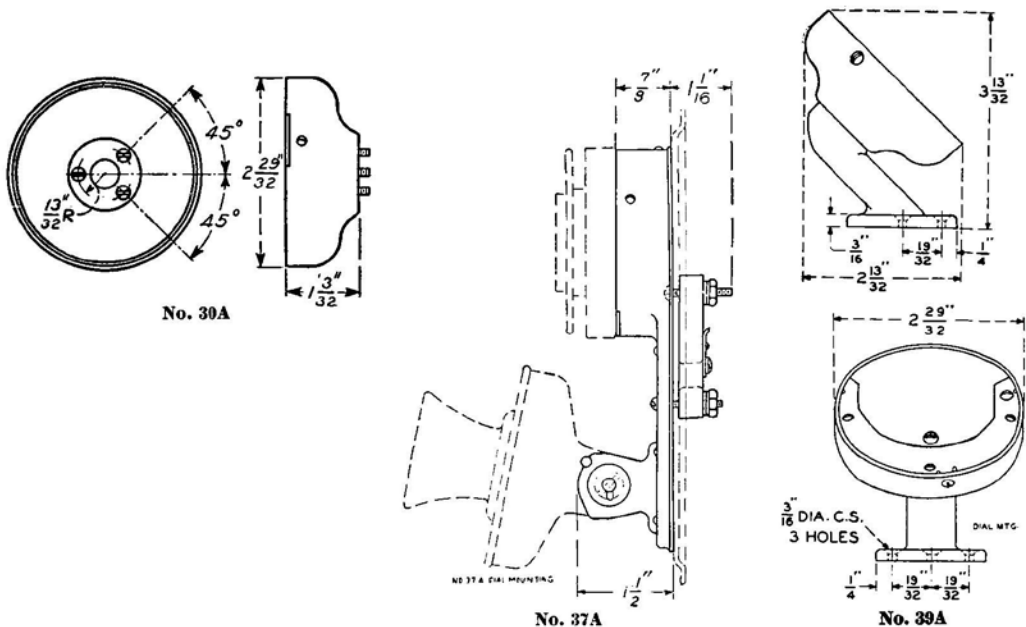

These Dial Mountings in connection with the No. 52 Type Dial Adapter are designed for mounting Western Electric No. 2 or 4 Type Dials.

By the use of these mountings manual telephones may be arranged for machine switching service. These mountings are made of metal and have a black finish.

Code No.

Use and Description

- 30A Intended to mount on wall type telephones. Three machine screws are furnished. Wood screws can be substituted if desired.
- 32A For use in conjunction with 52 Type Dial Adapters for mounting No. 2 or 4 Type Dials. Consists of the No. 30A Dial Mounting provided with a black finished base for mounting Dial in a vertical position on local test desks and P.B.X. switchboards. Furnished with mounting screws.
- 37A Used to convert for dial service certain manual subscriber sets of the Nos. 124, 293, 296, 333, 433, 533 and 633 types. Intended to mount 323 or similar type transmitter and a No. 4H Type Dial to which a No. 52C Dial Adapter has been attached. One M4J cord, a connecting block and mounting screws are furnished as part of this apparatus.
- 39A Intended for use with C1 Type handset mountings and Nos. 101 or 201 Type hand telephone sets for mounting 2H or 4H Type Dials. Consists of an offset pedestal to which is assembled a bell-shaped part on which a 52C Dial Adapter is mounted. Provided with mounting screws. Provided in colors as follows:

Code	Color	Code	Color
39A-3	Black	39A-7	Statuary Bronze
39A-4	Ivory	39A-8	Oxidized Silver
39A-5	Gray	39A-11	Medium Gold
39A-6	Old Brass	39A-12	Dark Gold

6000 Type Dial Mountings

The 6000 Type Dial Mountings are for use in conjunction with the 52B Dial Adapter for mounting 2E or 4E Type Dials. Provided with a connecting block which can be permanently attached to the mounting surface and with a cord which is used to connect the Dial to the spring of the 34 Type Dial Mounting which is a part of this equipment.

The 6000D and 6000E Dial Mountings are arranged to mount on a switchboard keyshelf or other horizontal surface. The 6000F is arranged to mount in a vertical position. The 6000D is provided with a locking screw to prevent removal without the use of a tool.

Code No.	Consists of			Use
	Dial Mounting	Connecting Block No.	Cord No.	
6000D	34D	25B	765	At unattended pay stations and unsupervised P.B.X. switchboards.
6000E	34E	25B	765	At central office and supervised P.B.X. switchboards.
6000F	34F	25B	821	On test sets. Recommended in place of 36A Dial Mounting.

Dial Number Plates

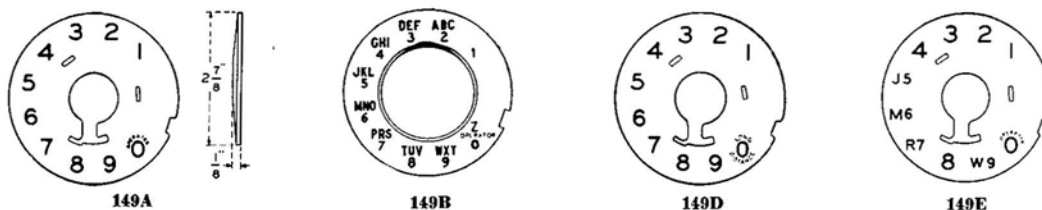

These Number Plates consist of a steel base coated with cellulose acetate lacquer. A small lug projecting from the back fits into a hole in the dial frame thereby insuring proper alignment of the Number Plate with regard to the finger wheel of the dial.

Code No.	Color of Characters	
	Numerals	Letters
149A	Black	Black
149B	Red	Black
149D	Black	Black
149E	Black	*
149H	No Characters	

* Word "Operator" is in black, other letters are in red.

147B NUMBER PLATE

Consists of a circular Number Plate equipped with three studs for mounting on a 56A Dial Adapter. The letters and characters are similar to those on the 149B Number Plate. The outside diameter is approximately 4 $\frac{3}{8}$ " and the thickness over the studs is approximately $\frac{5}{32}$ ".

Intended for use with a 56A Dial Adapter and a No. 2 or 4 Type Dial on a No. 50 Type Coin Collector in dial systems.

Dial Opening—Apparatus Blanks

The following Apparatus Blanks as described under the heading "Apparatus Blanks" are used to cover unequipped dial positions in various types of apparatus.

Nos. 50B, 50C Type, 50D, 50E, 50H Type, 50J Type.

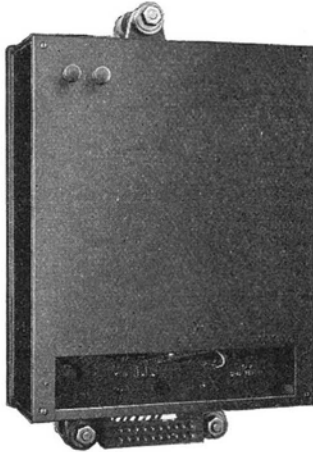
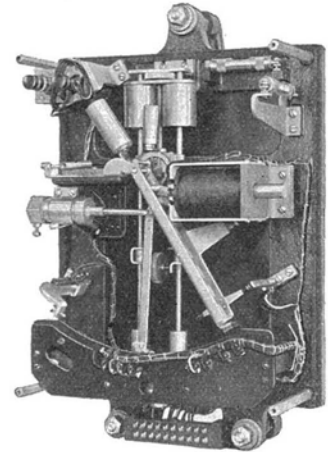
51C DIAL TESTER**With Cover****Cover Removed**

A pendulum type Dial Tester used for checking the pulse rate of dials. Operates on 48 volts D.C. in either manually or remotely controlled circuits, and passes a tone indication for the normal, sub-normal or above normal rates of dial speed to test-man or subscriber's station. Enclosed in a metal cover having a window for observing the contact arm when checking the speed and decrement loss of the pendulum.

It will check the speed of dials having the following limits:

Test Limits	Step-by-Step	Readjustment Limits
8 and 11 pulses per second		$9\frac{1}{2}$ and $10\frac{1}{2}$ pulses per second
11 and 13 pulses per second		11 and 13 pulses per second
	Panel Type	
16 and 20 pulses per second		17 and 19 pulses per second
8 and 11 pulses per second		$9\frac{1}{2}$ and $10\frac{1}{2}$ pulses per second

This Dial Tester is equipped with two spirit levels for setting the Tester in a true perpendicular position.

It is arranged to mount on a No. 16A Bracket which is not furnished and must be ordered separately.

DISTRIBUTING FRAMES

These distributing frames have been designed to meet the requirements of small central offices where simple and compact protective equipment is desired.

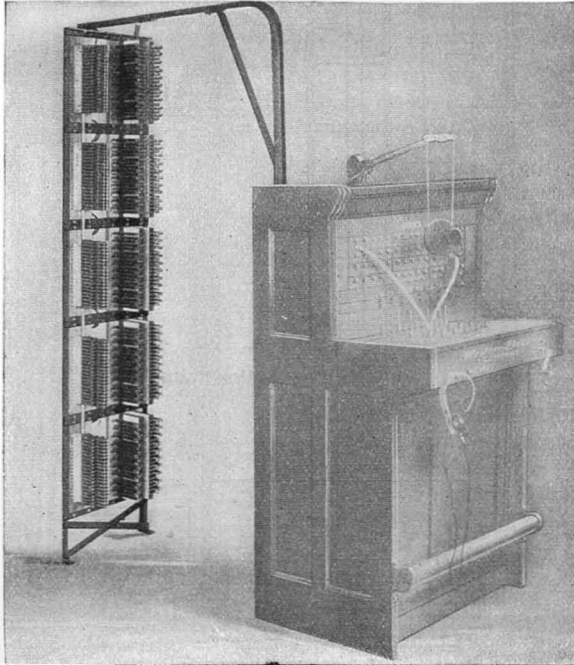

No. 1430 Type Main Distributing Frame

These frames are built in units of two verticals, one vertical for mounting the terminal apparatus of the outside lines, and the other vertical for mounting the terminal apparatus of the inside lines.

Facilities for cross connection between the inside and outside lines are provided by the distributing rings on the back of each protector group. These frames are designed to be supported by the switchboard sections.

Each unit will accommodate 100 metallic telephone lines by using the protector groups described and illustrated under "Protector Groups." The protector group equipment desired should be specified on each order.

These frames have the following important features:

1. Steel Framework. The framework is of steel, forming a rigid support for the apparatus. A rust resisting finish is applied.

2. Ease of Access. The framework is so constructed that cross connections and inspections can be easily made.

3. Unit Type. The framework is built in 100 line units and is so arranged that several units may be lined up to form a frame of larger capacity. It is only necessary to purchase enough frame to handle your present requirements, and later increase your frame capacity as the number of lines increases.

4. Universal Design. All of the vertical mountings are arranged so that our standard protector groups can be mounted. By the addition of a small steel supporting bracket, the No. 1430 Type Frame can be converted into the No. 1420 Wall Type Frame described later.

5. Minimum Floor Space. Due to their compact design, these frames occupy very little floor space.

Code No.	Used with Switchboards	Capacity		Protective Groups Used	
		Inside Lines	Outside Lines	Inside Lines	Outside Lines
1430F	No. 1240D.....	100	100-125	1435W	1435U or R
1420B	Any non-multiple switchboard.....	100	100-125	1435W	1435U or R

DISTRIBUTING FRAMES

NOS. 1430 and 1420 TYPES—Continued

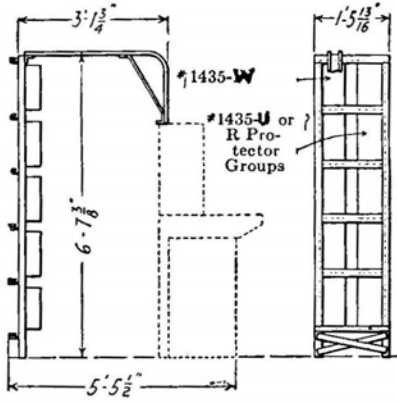

No. 1430F Distributing Frame

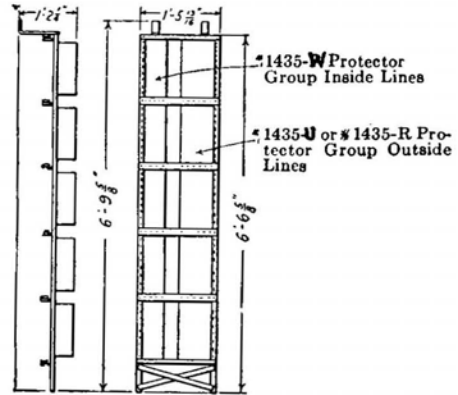

No. 1420B Distributing Frame

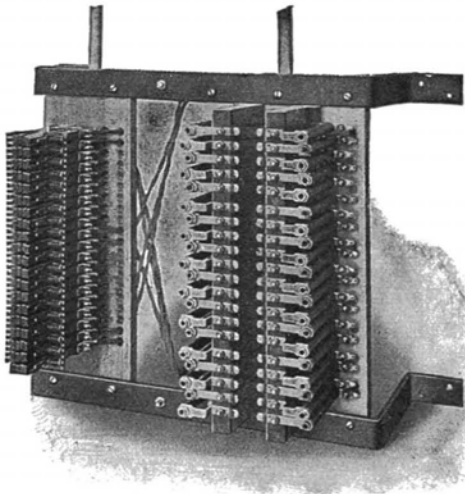

No. 1431A 20 Line Main Frame

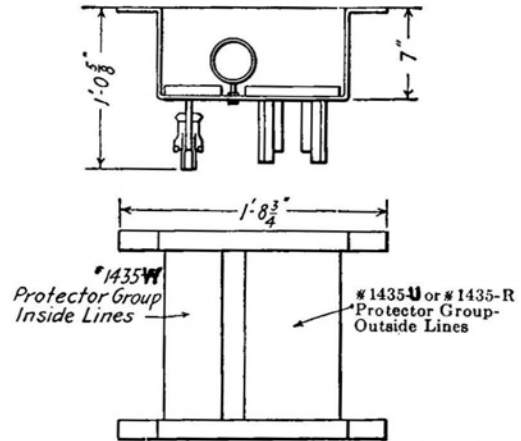

NO. 1431A 20 LINE MAIN FRAME

This frame has been designed to satisfy a demand for a small capacity, inexpensive, and yet sturdy distributing and protective equipment.

It is especially suitable for the small rural exchange owning and operating a No. 1800 or other switchboard, equipped for from 10 to 40 lines, with little prospect of immediate growth.

Where more than 20 lines are to be accommodated, two of these frames can be lined up, one above the other. Cross connection facilities are provided by rings on the back of the frame.

This frame is designed for mounting against the wall. The drilling is so arranged that our standard protector groups can be used.

In ordering this frame specify the protector groups desired. (See description of protector groups.)

Code No.	Used with	Capacity		Protector Groups Used	
		Inside Lines	Outside Lines	Inside Lines	Outside Lines
1431A	Any small switchboard.....	20	20-25	1435W	1435U or R

DISTRIBUTING FRAMES

NO. 1425 TYPE

This is a unit type frame, adapted for telephone central office or exchange protective apparatus where the Nos. 1420 or 1430 Type Frames are too small for present requirement or future growth.

Fuses. No provision is made for mounting on this frame abnormal current fuses. If it is considered necessary to equip certain lines with this type of protector, it is suggested that they be mounted elsewhere, such as on the wall or on a special frame constructed for the purpose.

Construction. This frame is rigidly constructed of steel angles and bar iron, and is made up in units of one vertical each, three verticals of this frame being shown in the accompanying illustration.

Each unit has a vertical bar which is arranged for mounting five No. 1435T Protector Groups which provide protectors of the carbon block and heat coil type for 100 magneto or central battery lines. Each protector group accommodates 20 lines.

This vertical protector bar is called the "vertical side" of the frame. The switchboard cables or inside lines are usually connected to these protectors.

Rubber covered distributing rings are placed conveniently, making it easy to run the jumper wires in a uniform, compact and neat manner, without going through more than one ring or making more than one turn.

The unit type of framework makes it possible, by lining up together a number of vertical units, to build a frame of any required capacity.

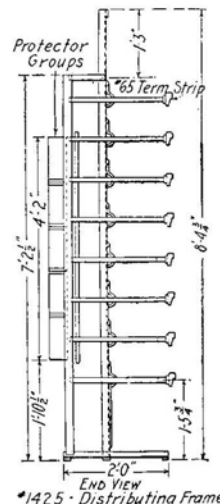

*1425 - Distributing Frame

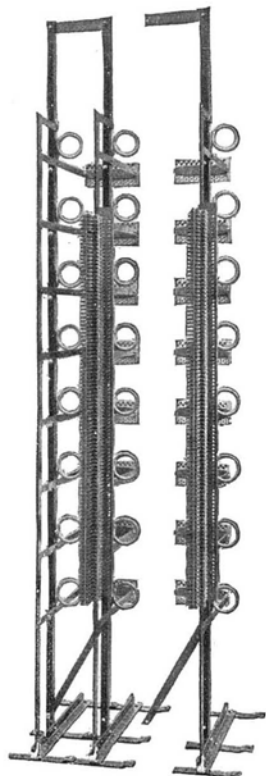

This shows two units of No. 1425C distributing frame lined up and bolted together. As many 100 line units as desired may be installed.

Two units are necessary at the beginning of the frame; one unit for each additional 100 lines.

This is one 100 line unit of No. 1425C distributing frame. The Code No. 1425C covers the steel framework, distributing rings and fanning strip, but does not cover the protector groups and No. 65 terminal strips. The terminal strips for terminating 20 pairs of outside cable may be ordered as follows:
 ----- No. 65 terminal strips. The carbon, mica and heat coil protector may be ordered as follows:
 ----- No. 1435T Protector groups each accommodating 20 inside or switchboard pairs. These protector groups are suitable for both Central Battery and magneto lines.

Initial Equipment. For initial equipment at least two units or verticals must be ordered and installed (which provide space for a maximum of 200 inside lines and 160 outside lines), as the No. 65 Terminal Strips to which the outside lines connect are mounted horizontally between adjacent vertical units, thus requiring at least two verticals to support a row of them. Eight of these terminal strips providing terminal facilities for 160 outside lines can be mounted between any two adjacent vertical units of the frame.

For Example:

1. 1425C Frame provides space for 100 protectors (or 100 inside lines) and no outside lines.
2. 1425C Frames provide space for 200 protectors (or 200 inside lines—*see note) and 160 outside lines.
3. 1425C Frames provide space for 300 protectors (or 300 inside lines—*see note) and 320 outside lines.

***Note.** It is not customary to equip the first vertical unit with protectors, but to mount on it the required terminal equipment for miscellaneous inside circuits. The No. 65 or similar type terminal strips can be mounted on the vertical side of these frames for this purpose. In ordering terminal strips for use on this frame, however, so specify on the order, so that proper mounting details may also be furnished.

INFORMATION

Code No.

*1425C

"Vertical Side"
Inside Lines

Magneto or central battery lines—No. 1435T
Misc. inside circuits—No. 53 Terminal Strip

Protector Groups Used

"Horizontal Side"
Outside Lines

No. 65 Terminal Strips

* This Code number includes one vertical unit of this frame and distributing rings only. The protector groups and terminals must be ordered separately.

DISTRIBUTING RINGS



No. 8A



No. 1



No. 3

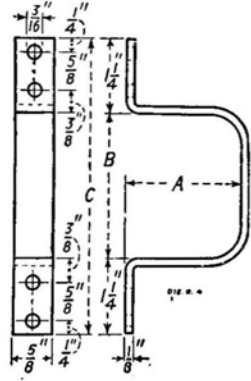

No. 4

Code No.	Dimensions Inches	
	Outside	Inside
1	3 7/8	2 7/8
2	4 7/8	3 7/8
3	4	3

Description and Use
Steel with hard rubber covering for distributing frames.

Code No.	Dimensions Inches		
	A	B	C
4A	1 7/8	2 3/8	4 7/8
4B	2 7/8	3 5/8	6 1/8
4C	2 7/8	5 5/8	8 7/8
6A			

Description and Use
Steel with black finish for No. 23 Cable Terminals.

Metal hook covered with black insulating material for step-by-step machine switching selector frames with distributing terminal assemblies.

Code No.	Dimensions (Overall) Inches	
	A	B
8A	2 11/16	1 5/16

Description and Use
Metal support intended for use in "GA", "GB" or "GC" Type Cable Terminal Boxes. Provided with mounting screw and washer.

DROPS

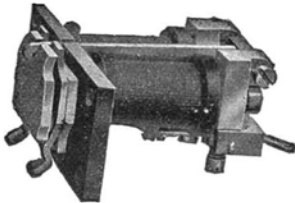

No. 4A Drop

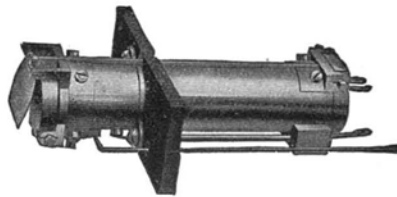

No. 22A Drop

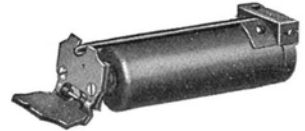

No. 56A Drop

The No. 4 Type Drops are equipped with two electromagnet spools each.
The Nos. 22, 35 and 56 Types are single spool drops with tubular iron shells and are cross-talk proof.
The Nos. 4, 35 and 56 Drops must be restored manually.
The No. 22 Drop is restored electrically and has two windings, one for operating and one for electrical restoration.
The No. 35 Type Drop is equipped with two windings, one front and one back in order that it may be used in selective signaling. When so used the middle of the winding (and one side of the associated ringing generators) is grounded.

All drops will operate on alternating ringing current.

All drops are equipped with night bell contacts. These contacts remain closed until the drop is restored.

Code No.	No. of Windings	Approximate Resistance (Ohms)	Finish of Shutters	Mounting Centers (Inches)	Overall Dimensions (Inches)			Used with Drop Mountings
					High	Wide	Deep	
4A	1	90	Black	1 3/8	(1 1/64)	1 5/16	2 3/8	{ 2, 57, 58, 60, 65, 68 }
4C	1	1000	Black	1 3/8				
22A	2	{ 700 45	Line Restoring	Aluminum	1 3/8	1 11/32	1 1/2	5 5/32
35A	2	285			Black	1 1/4	(1 1/64)	1 3/16
35C	2	{ 10.5 11.3	Inner	Black	1 1/4			
56A	1	525	Black	1	(3 1/32)	3 1/32	3 37/64	{ 2, 53, 56, 57, 58, 64, 68, 69, 83, 84 }
56B	1	670						
56M	1	20						

DROPS

Piece Parts for Nos. 4A, 4C and 22A Drops

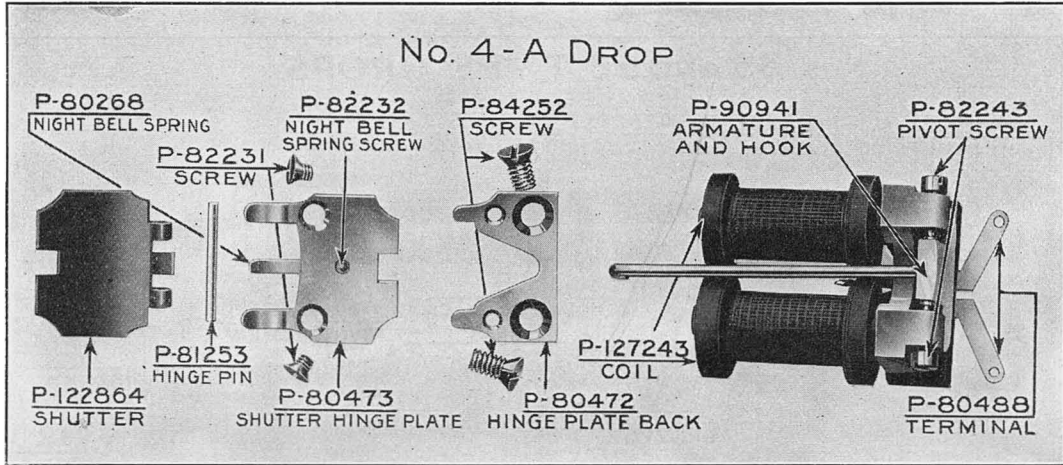

Note. Coil for 4C Drop—P-127245. Armature for 4A and 4C Drops P-81273

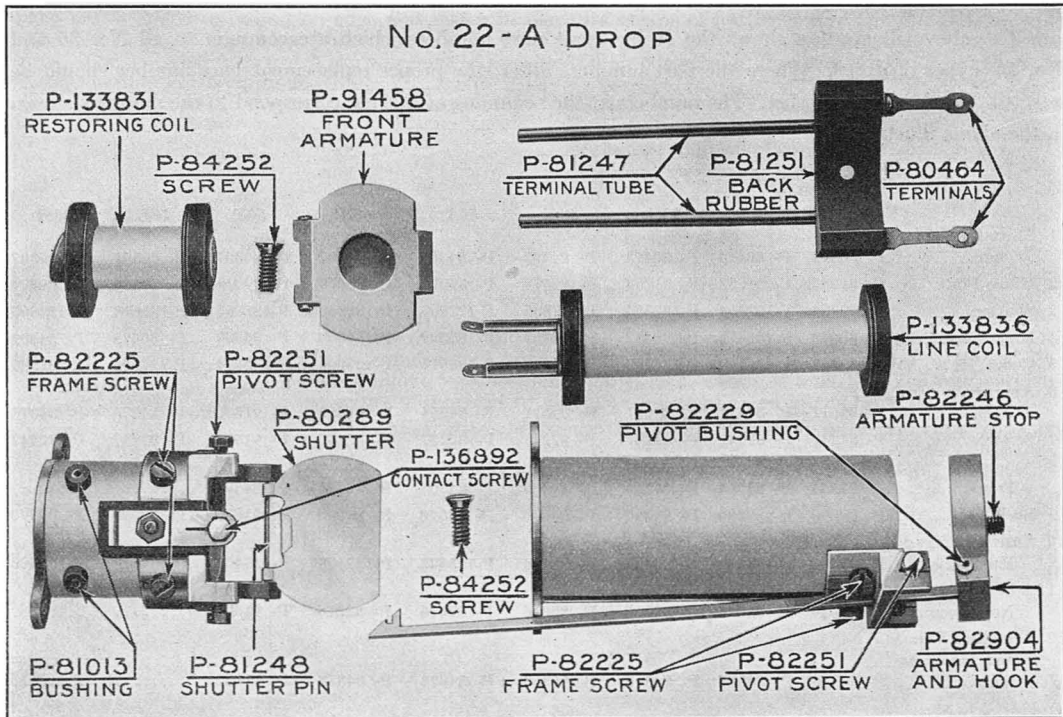

DROPS

Replacement Parts for Nos. 35 and 56 Type Drops

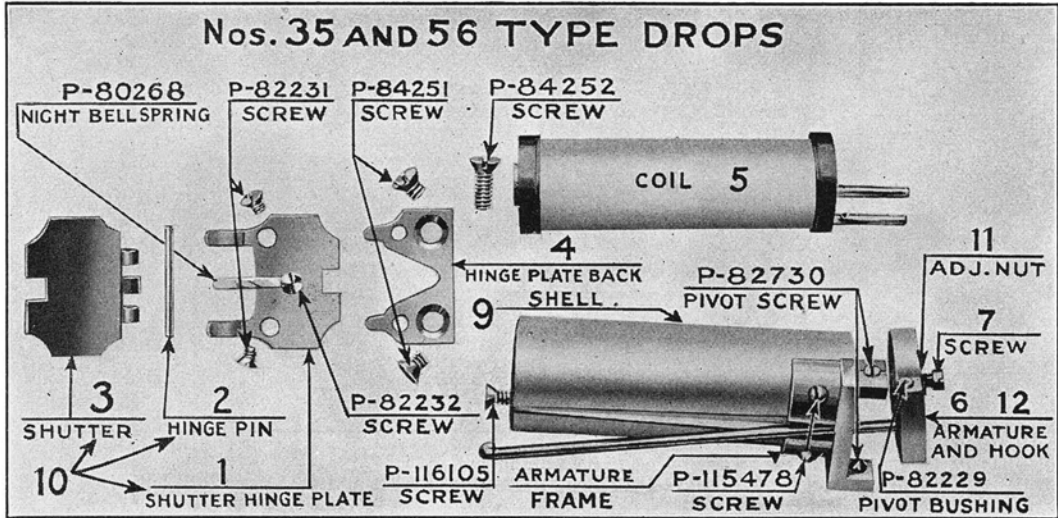

The above illustration shows the replacement part numbers which are common to all No. 35 and No. 56 Types of drops. Where the part numbers differ, the proper replacement part number should be selected from the following list. The numbers at the beginning of this list correspond to the numbers shown in the above illustration.

	35A	35B	35C	35E	56A	56B	56F	56L	56M
1 Shutter Hinge Plate.....	P- 80473	P- 80473	P- 80473	P- 84307	P- 84307	P- 84307	P- 84307	P- 84307	P- 84307
2 Hinge Pin.....	P- 81253	P- 81253	P- 81253	P- 89079	P- 89079	P- 89079	P- 89079	P- 89079	P- 89079
3 Shutter.....	P-122864	P-122864	P-122864	P-122865	P-122865	P-122865	P-122865	P-131618	P-122865
4 Hinge Plate Back	P- 80472	P- 80472	P- 80472	P- 84309	P- 84309	P- 84309	P- 84309	P- 80472	P- 84309
5 Coil.....	P-132448	P-132449	P-132450	P-126668	P-132514	P-127006	P-132514	P-127006	P-201389
6 Armature and Hook.....	P- 89611	P- 89611	P- 89611	P- 89611	P- 84654	P- 84654	P- 91342	P- 84878	P- 84878
7 Screw.....	P- 82247	P- 82247	P- 82247	P- 82247	P- 82247	P- 82247	P- 91349	P- 82247	P- 82247
8 Armature and Frame.....	P- 81254	P- 81254	P- 81254	P- 84306	P- 84306	P- 84306	P- 84306
9 Shell.....	P- 89090	P- 89090	P- 89090	P- 89090	P- 89090	P- 89090	P- 91633	P- 89090	P- 89090
10 Shutter Hinge Plate Assem....	P-123409	P-123409	P-123409	P-123408	P-123408	P-123408	P-123408	P-131619	P-123408
11 Adj. Screw and Nut Assem....	P- 82016	P- 82016	P- 82016	P- 82016	P- 82016	P- 82016	P- 91384
12 Armature Frame and Hook Assem.....	P- 84915	P- 84915	P- 84915	P- 91369	P- 84878	P- 84878	P- 91352

DROP MOUNTINGS



No. 58 Drop Mounting

All Drop Mountings are of metal construction with black finished faces.

Code No.	Number per Strip	Centers Inches	Size of Plate Inches	For Drops Number	Used on Switchboards Number
2	10	1 $\frac{3}{8}$	15 x 1	4, 35, 56	101, 102, 1006, 1010, 1011
56	20	1 $\frac{1}{8}$	24 $\frac{3}{16}$ x 1	56	9, 1800
58	15	1 $\frac{3}{8}$	21 $\frac{3}{4}$ x 1	4, 35, 56	105, 1005

Drop Spaces

Wooden strips with ebonized face arranged to mount interchangeably with Drop Mountings as listed below. Intended for use in place of Drop Mountings when a switchboard is not fully equipped.

Code No.	Size of Face Inches	Corresponding Drop Mountings
2	15 x 1	2
7	24 $\frac{3}{16}$ x 2 $\frac{3}{32}$	56

FANNING STRIPS AND FUSES

Fanning Strips

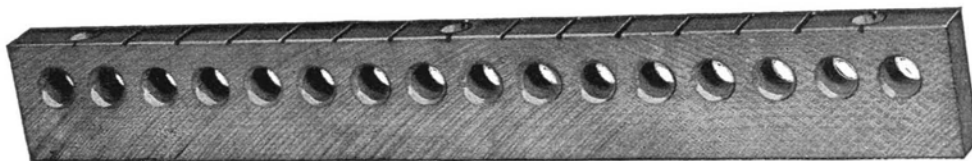

No. 15A

Made from well seasoned maple. The dimensions are 1 $\frac{1}{16}$ x $\frac{1}{2}$ inches with lengths as given below. They are designed to mount on edge and fasten in place by means of flat head screws. The outside edge is finished black, so that white characters may be painted upon this surface for identification of the various wires. The holes through which the wires are to pass have their edges carefully chamfered in order that the insulation may not be injured.

Code No.	Replaces	Capacity Pairs	Length Ins.	Used with Connecting Block	Protector
10		13	22 $\frac{5}{8}$	1079
15A	2 and 7	16	10 $\frac{7}{16}$	30C and 31C
15B	4, 9	26	16 $\frac{1}{16}$	30D and 31D

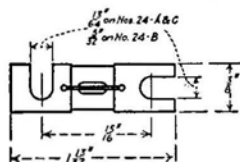

No. 24 Type Fuse

Code No.	Rated Capacity Amperes	Operates in Less than One Minute on Amperes	Terminals	
			Finish	Slotted for Screw No.
24A	1/2	1	Tinned	10
	1 1/3	2	Tinned	10
	1/2	1	Copper	6
24B	1 1/3	2	Copper	6
	2	3	Copper	6
	3	4	Copper	6
24C	2	3	Copper	10

FUSES

Non-Alarm Type

These phenol fibre fuses will mount on 1 inch centers by means of Fuse Posts or individual porcelain mounting as in the No. 62D Protector. The overall dimensions are: length 11 $\frac{3}{32}$ inch, width $\frac{3}{8}$ inch. The current carrying capacities and operating current values are given in the table below.

In ordering it is necessary that both the code number and rated capacity be given.

FUSES—Continued

Indicator Alarm Type

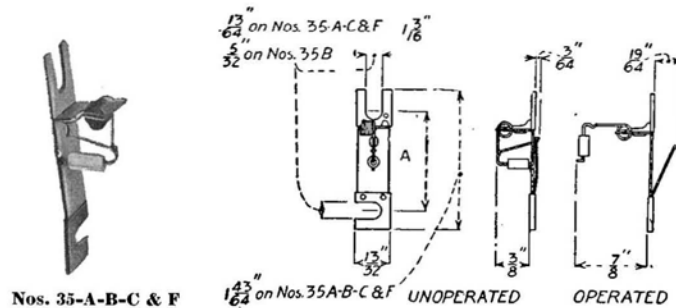

These phenol fibre fuses have the fuse wire so mounted that one end is fastened to a coiled spring and the other to a flat spring on the opposite side of the base. The terminal ends have a copper tinned finish.

When the fuse operates, the coiled spring causes a glass bead to be brought into a prominent position where it acts as a visible indication of the blown fuse. The mounting of the fuse may be so arranged as to cause the flat spring on the bottom of the fuse to make contact with an alarm circuit when the fuse wire is broken.

No. 35 Type Fuses may be mounted as in the No. 62C Protector or by means of Fuse Posts. They operate on currents fifty per cent in excess of those for which they are rated.

When ordering, both the code number and rated capacity should be specified.

Code No.	Rated Amperes	Operates on		Color of Bead	Slotted For Screw	"A" Mounting Centers Inches
		Amperes	In Less Than			
35A	1 1/3	2	1 1/2 min.	White	No. 10	1 1/4
35B	1 1/3	2	1 1/2 min.	White	No. 6	1 1/4
35C	2	3	3 min.	Orange	No. 10	1 1/4
35D	1 1/2	2	1 1/2 min.	White	No. 6	1 3/16
35E	3	4	5 min.	White	No. 6	1 3/16
35F	1/2	3/4	1 1/2 min.	Red	No. 10	1 1/4
35G	3	4 1/2	5 min.	Blue	No. 6	1 1/4
35H	5	6 1/2	5 min.	Green	No. 6	1 1/4
*35J	1/2	3/4	1 1/2 min.	Red	No. 10	1 1/4

* For use in circuits using 100 to 160 volts. Fuse wire is enclosed in glass tube to prevent side flash.

Dummy Fuses

These fuses are composed of black insulating material and are for use on fuse panels not equipped with fuses.

Code No.	Fuses Used In Place of	Overall Dimensions Inches
63A	35A, B, C or F	1 3/64 x 1 3/32 x 3/64
64A	24 or 44 Type	1 3/8 x 1 3/32 x 3/64

Tubular Fuses



These fibre shell type Fuses are carefully made from especially selected materials. The use of lead fuse wire prevents the possibility of overheating the shell. These Fuses will carry their rated currents indefinitely without injury and will act reliably on one and one-half times their rated current values. Fuses of the same code number and rated capacity will give consistent performance as to rated and operating current values.

Code No.	Rated Capacity Amperes	Used with
7A	1 to 8 as specified	Nos. 77, 1074A, 1075A and 1078A Protectors.
7T	7	"B" Cable Terminals and Fuse Chambers.
11C	7	Nos. 58AP and 1079AP Protectors.
11D	7	No. 25 Protector Mounting (No. 12 Type Protector.)

PORCELAIN SHELL FUSES

In certain cases where lines are exposed to high potential crosses, it is advisable to insert a Fuse in the drop wire near the crossarm in addition to the No. 60AP Protector installed at the telephone station. In such cases the No. 47 Type is recommended; the porcelain shell used on this type of Fuse will break upon the passage of a large current or upon the continued flow of smaller current. The wires in which the Fuses are inserted will fall apart as the shells break, and the line end of the wire, being close to the crossarm, will not come in contact with objects on the ground. These Fuses operate on one and one-half times their rated capacity.



No. 47A

Code No.	Capacity
47A	7 amperes
47B	14 amperes

60 Type Fuses



No. 60A

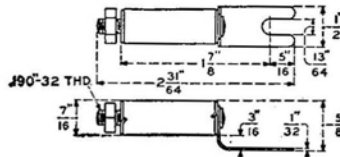

Dimensional Drawing, No. 60A

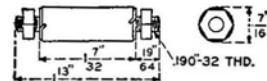

Dimensional Drawing, No. 60D, E & F



No. 60D, E & F

The 60 Type Fuse is a tubular Fuse having the fuse element enclosed in a sleeve of insulating material.

The 60A and D Types at a normal room temperature of 68° Fahrenheit will carry a current of .350 amperes for three hours and will operate in less than 210 seconds with a current of .500 amperes.

The 60E Type at a normal room temperature of 68° Fahrenheit will carry a current of 1.25 amperes for three hours and will operate in less than 210 seconds with a current of 1.80 amperes.

The 60F Type at a normal room temperature of 68° Fahrenheit will carry a current of .179 amperes for three hours and will operate in less than 60 seconds with a current of .267 amperes.

Code No.	Color of Shell	Protector Mounting	Used with
60A	Red	16 & 88	58AP or 1079AP Protectors
60D	Red	..	"LA" or "LB" Type Fuse Chambers
60E	Black	..	"LA" or "LB" Cable Terminals
60F	Red	..	Power Ringing Circuits

Glass Shell Fuses



No. 55A

This Glass Tube Type Fuse is equipped at both ends with tinned caps to which the fuse element is attached. Designed to mount in the No. 9A Fuse Block. Overall length of Fuse is 2 11/64 inches.

Code No.	Will Carry		Will Blow On	
	Amperes	For Minutes	Amperes	In Less Than
55A	.400	..	.800
62B	.250	15	.375	210 seconds

Fuse Blocks

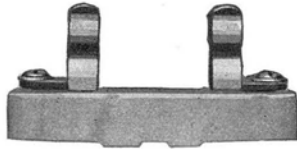

No. 9A Fuse Block

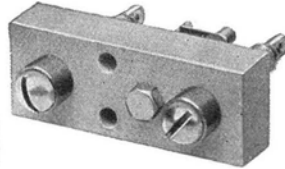

No. 12 Type

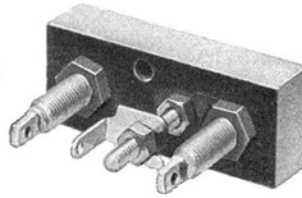

No. 13A

NO. 9A TYPE

A porcelain Block provided with clips for holding one No. 55A Fuse.

NO. 12 AND NO. 13 TYPES

The 12 and 13 Type Fuse Blocks are Blocks of insulating material equipped with two Fuse Posts. They are arranged for use on 7/32" Mounting Plates. To permit insertion and removal of Fuses, the following clearances are necessary between the centers of the Fuse Posts and the adjacent surface of the apparatus.

When Mounted Vertically (Top Post for Transverse Slot of Fuse)

7/8" to Left of Post
3/4" above Top Post

When Mounted Horizontally (Right Post for Transverse Slot of Fuse)

3/4" to Right of Post
1/8" above Posts

The No. 12 Type is equipped with an alarm stud and terminal. When mounted either horizontally or vertically will mount on 13/16" centers when placed side by side or 2 1/16" centers when placed end to end. Screws for mounting are provided.

The No. 13A Fuse when mounted either horizontally or vertically will mount on 1/2" centers when placed side by side or 1 1/16" centers when placed end to end. Provided with insulating bushings and washers.

Code No.	Equipped with Fuse Post Nos.	Arranged for Fuses
12C	{ 1-5E 1-5F }	35A, 35C, 35F, or 35J
12D	{ 1-6C 1 Modified 6C }	35B, 35G, or 35H
13A	5E	24A, or 24C

Fuse Chambers

For information regarding Fuse Chambers refer to Page 42 under "Cable Terminals".

Fuse Posts



No. 2A



No. 5A



No. 7A

These Fuse Posts are made of brass and have the head of the screw used for clamping the Fuse in place finished to correspond with the finish of the Fuse end.

Fuses up to and including 1 1/3 ampere capacity are supplied with tinned terminals; Fuses of 2 or 3 amperes capacity have copper terminals.

The Nos. 5 and 6 Type Fuses will mount on 1/2" centers except Nos. 5D, 5F and 6D which mount on 9/16" centers.

Code No.	—Overall Dimensions, Inches—			Finish	Screw No.	Used With Fuse No.
	Length	Width	Depth			
1C	1 9/16	5/16	5/8	Tinned Brass	6	Nos. 24 and 35 Types
2A	1 1/2	3/8	1/4	Nickel Dip	8	Nos. 24 and 35 Types
5A	2	3/8	..	Nickel Dip	..	Nos. 24 and 35 Types
5B	2	3/8	..	Brass	..	Nos. 24 and 35 Types
5C	2 3/4	3/8	..	Nickel Dip	..	Nos. 24 and 35 Types
*5D	2	3/8	..	Nickel Dip	..	Nos. 24 and 35 Types
5E	1 5/8	3/8	..	Nickel Dip	..	Nos. 24 and 35 Types
*5F	1 5/8	3/8	..	Nickel Dip	..	Nos. 24 and 35 Types
6	2	3/8	..	Brass	..	Nos. 24 and 35 Types
6B	2	3/8	..	Nickel Dip	..	Nos. 24 and 35 Types
6C	1 5/8	3/8	..	Nickel Dip	..	Nos. 24 and 35 Types
*6D	2 3/4	3/8	..	Nickel Dip	..	Nos. 24 and 35 Types
7A	1 15/64	3/8	1/8	Tinned Brass	6	Nos. 24 and 35 Types
7B	1 15/64	3/8	1/8	Tinned Brass	6	Nos. 24 and 35 Types

* Provided with a clip to prevent engagement of the transversely slotted ends of No. 35 Type Fuses.

GAUGES

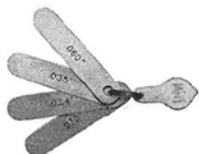

38B Gauge



No. 106A Gauge Cover at Right

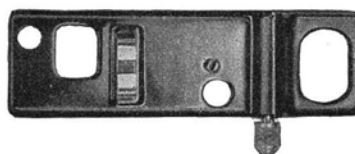

Code No.	Description and Use		
27	For determining when the parts of the No. 109 Type Plugs have reached the limit of wear.		
33	A steel gauge for gauging the sleeves of No. 49 Jacks. The gauge plug P-97443 is detachable from the handle and may be ordered separately if desired.		
35	Dry battery gauge for testing dry batteries in transmitter pole changer and coin collector service. Provided with a 20 ohm winding for transmitter service when testing three cells in series and a 5 ohm winding for single cell in pole changer service. Equipped with two 18" No. 361 Cords.		
37B	Intended for use in adjusting ringers and loud ringing bells on common battery non-polarized ringing lines (individual, 2-party selective, 4-party semi-selective and 10-party divided code ringing). Consists of three thickness gauges .012, .024 and .035 inches held together by a brass ring.		
38B	Intended for use in adjusting ringers and loud ringing bells on common battery non-polarized and polarized ringing lines. Consists of four thickness gauges .012, .024, .035 and .060 inches held together by a brass ring.		
43	Consists of one .012 inch thickness gauge and one .016 inch thickness gauge held together by a brass ring. Intended for gauging the air gap between the armature stop pin and the core of Nos. 2 and 38 Type Ringers respectively.		
66D	Consists of the following gauges assembled on a holding ring. Intended for use in adjusting the armature travel of relays.		
1-67A	.015"	1-67H	.004"
1-67B	.020"	1-67J	.008"
1-67C	.025"	1-67K	.005"
1-67D	.030"	1-67L	.006"
1-67E	.035"	1-67M	.010"
1-67F	.040"	1-67N	.023"
1-67G	.003"	1-67P	.045"
70D	Consists of a nickel silver frame on one side of which is a scale having equally spaced graduations. For use in gauging the tension of relay springs in which the tension does not exceed 50 grams. Scale 50-0-50 grams. Scale graduations 5 grams. Replaces No. 70.		
70E	Consists of a nickel silver frame on one side of which is a scale having equally spaced graduations. For use in gauging the tension of relay springs in which the tension is above 50 grams. Scale 150-0-150. Scale graduations 12.5 grams. Replaces 70B.		
70F	Consists of a nickel silver frame on one side of which is a scale having equally spaced graduations. For use in gauging the tension of relay springs in which the tension is 10 grams or less. Scale 10-0-10. Scale graduations 1 gram. Replaces 70C.		
70G	Consists of a nickel silver frame on one side of which is a scale having equally spaced graduations. For use in measuring the tension of ringer biasing springs. Scale 50-0-50. Scale graduations 5 grams.		
95A	Consists of a steel gauge equipped with a wooden handle for gauging the back contact air gap on certain relays of the Nos. 114 and 198 Types.		
99A	For use in adjusting the armature or air gaps of "B" and "G" Type Relays. Consists of the following gauges assembled on a holding ring:		
100A	.005"	100H	.040"
100B	.010"	101A	.030"
100C	.015"	101B	.035"
100D	.020"	101C	.040"
100E	.025"	101D	.050"
100F	.030"	101E	.060"
100G	.035"		
106A	Represents a jack with a sleeve worn to the limit of wear and is provided with a moveable anvil, shaped and located to represent a tip spring of a jack. The anvil which is pivoted, has a pointer attached to read against a scale. The scale has red and black lines which will show whether the plug is correct, needs straightening or should be discarded. Overall dimensions are 4 ²⁷ / ₃₂ " long, 2 ¹ / ₁₆ " wide, and 1 ³ / ₂ " thick. When gauge is to be mounted on repair table it requires 2 No. 23A Brackets for mounting, which must be ordered separately.		
111A	Same as 106A except arranged for testing 110 Plugs.		
113A	For use in testing 92 Jacks. Consists of a plug equipped with a plug shell and arranged for cord connection same as in the 109 Plug. In conjunction with a cord and a 121A cord weight, tests for possible cut-outs in service.		
114A	Same as 113A except designed to test for springs so close to the jack sleeve center line as to butt with a plug in service.		
115A	Same as 113A except designed to test for possible crosses in service between the springs of the jack when plug is inserted.		

GONGS

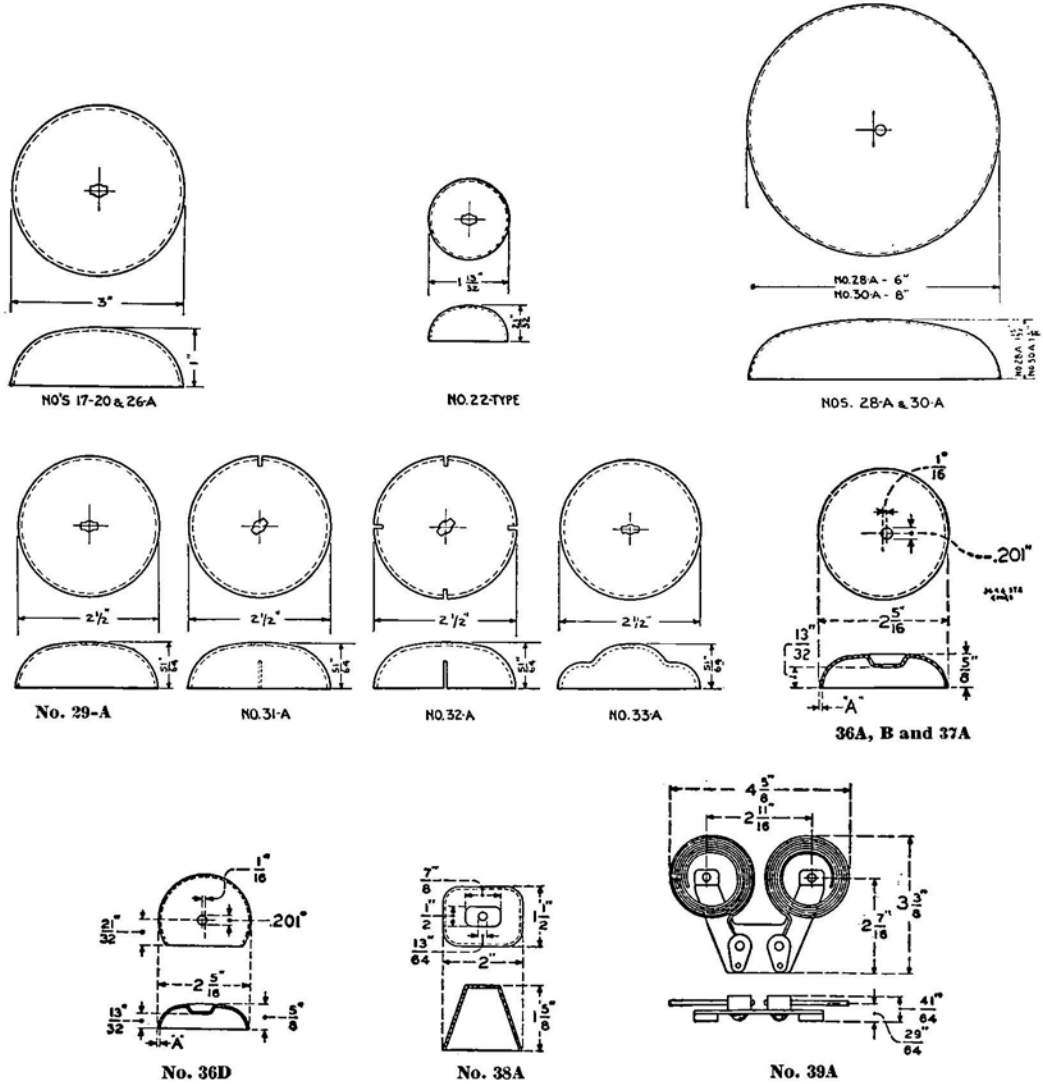

Western Electric standard 2 1/2 and 3 inch Gongs have mounting screw holes which are slotted for engaging the projections on the Gong Posts of standard ringers, thus making it impossible for telephone users to inadvertently put the ringer out of adjustment by turning the Gongs with the fingers (a frequent source of ringer trouble). These Gongs may also be used on Gong Posts which are not provided with projections for engaging the "wing" holes.

All Gongs here listed are formed from sheet metal.

Code No.	Description	Principal Use
3	Metal, nickel plated— 2" x 1 1/2" x 1 5/8"	Cow Gong—on standard ringers to give different tone.
10	Metal, nickel plated— 2 3/32" diam. 1 1/16" deep	Tea Gong—on standard ringers to give different tone.
20	Brass, special black finish	Finished to resist the action of moisture and fumes. For use in No. 1336 Type Mine Telephones and other places where similar service conditions are encountered.

GONGS—Continued

Code No.	Description	Principal Use
22A	Brass, nickel plated	For use on No. 40 Type Ringers. Each of these Gongs has a different tone.
22C	Brass, nickel plated	
22D	Steel, nickel plated	
22E	Brass, nickel plated	
22F	Steel, nickel plated	
26A	Brass, black finish	Standard 3 inch Gong for magneto telephones.
28A	Steel, hot dipped galvanized	No. 392 Type Extension Sets. Mounting screw hole drilled slightly off center to permit of adjustment.
29A	Brass, black finish	Standard 2½ inch Gong for general telephone use.
29C	Oxidized brass finish	In 533, 534, 553 and 554 Type Subscriber Sets using the 68A, H, J, AA, 72A, G and AC Ringers.
31A	Brass, black finish	Differ from the No. 29A in that they have different tones. Intended for use where a number of telephones are placed close to each other.
32A	Brass, black finish	
33A	Bell metal, black finish	
31C	Brass, unfinished	Alternative for 29C.
32C	Brass, unfinished	
33C	Bell metal, unfinished	
*36A	Brass, unfinished— Dim. A (Page 94) .045 in.	With 78A Ringer, in 584 Type Desk Set Box.
*36B	Aluminum, unfinished Dim. A (Page 94) .064 in.	Ordinarily used with the 584 Type Subscriber Set where a high pitched signal is desired.
*36D	Aluminum, unfinished Dim. A (Page 94) .064 in.	Ordinarily used with the 584 Type Subscriber Set where a highly damped signal is desired.
37A	Brass, unfinished Dim. A (Page 94) .064 in.	With 78A Ringer, in 584 Type Desk Set Box.
38A	Bell metal, black finish	Ordinarily used with 295 and 495 Subscriber Sets. Intended for use where a low pitched signal is desired particularly for certain partially deaf subscribers.
*39A	Steel, wire, blued finish	Ordinarily used with 584 Type Subscriber Sets. Intended for use where a pleasing tone signal of the "cathedral" type is desired.

* The four combinations of Gongs coded 36A, 36B, 36D and 39A constitute a set of four distinctive tone Gongs for use where two or more telephones are located close to each other.

Gong Mountings

Code No.	Description
7	Brass—Consists of a pair of Gong Posts or Gong Post Extenders together with two No. 6—32 x 5/16 in. R.H.M. Screws.

HAND GENERATORS

Western Electric Hand Generators are correct in both mechanical and electrical design and the materials used and manufacturing processes employed are such that their high efficiency is retained indefinitely. A few of the important features are as follows:

All parts are accurately machined and fitted and the bearings are of such size that no trouble due to the armature scraping on the pole pieces will be encountered even after years of service. The gears are accurately cut so that smooth, noiseless operation is obtained.

All metal parts are given a protective finish and the armature winding is moisture-proofed.

The magnets are made from steel which was developed especially for this purpose and the heat treatment employed is such that their strength is retained indefinitely.

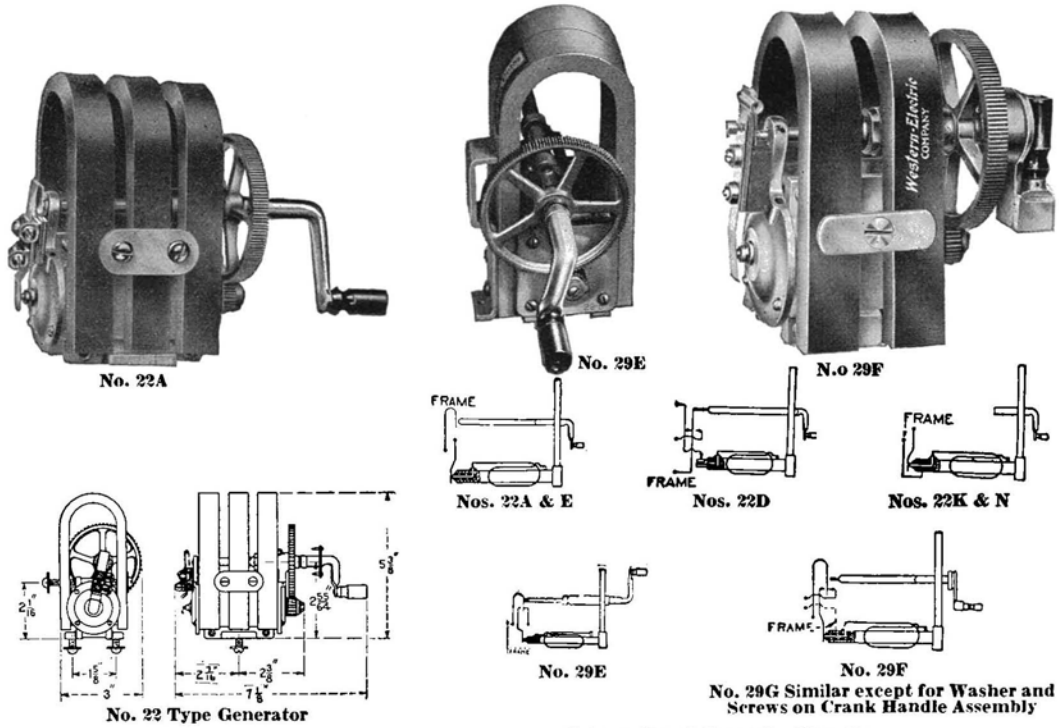

Schematics of Generator Circuits

NO. 22 TYPE GENERATORS

The No. 22 Type Generator is used on lightly loaded magneto lines and may be obtained either for alternating or pulsating current.

These Generators have three magnets except the No. 22E, which has only two.

With a non-inductive load of 2660 ohms and an armature speed of 1,000 R.P.M. (except No. 22N which is tested at 1,050 R.P.M.) will give voltages as shown below.

Code No.	Voltage	Generator Circuit	Principal Use and Description
22A	60 A.C.	Open	Telephones and small switchboards.
22D	43 P.C.	Closed	Telephones and small switchboards.
22E	42 A.C.	Open	Telephones. Same as 22A except that only two magnets are used. For use on lightly loaded four-party selective lines.
22K	60 A.C.	Open	Small switchboards where key is employed to open circuit or test sets.
22N	65 A.C.	Open	Small switchboards where key is employed to open circuit or test sets.

NO. 29 TYPE GENERATORS

The No. 29 Type Generators are used where light weight is essential as in linemen's test sets, and portable telephones.

The 29E Generator will ring fifty 2,500 ohm bells through 1,000 ohms resistance and five bells through 16,000 ohms resistance.

The 29F and 29G Generators will give 60 volts A.C. with a non-inductive load of 2,500 ohms and an armature speed of 1,025 R.P.M.

Code No.	Voltage	Generator Circuit	Principal Use and Description
29E	65 A.C.	Open	Has back contact. Used in portable telephones.
29F	60 A.C.	Open	Portable telephones and No. 1017 Type Test Sets. Has folding handle.
29G	60 A.C.	Open	Similar to No. 29F. Used in No. 1526B Telephone Set.

HAND GENERATORS—Continued



No. 48A

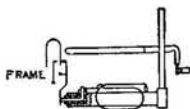

Nos. 48A, C & G

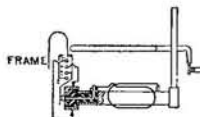

No. 48B

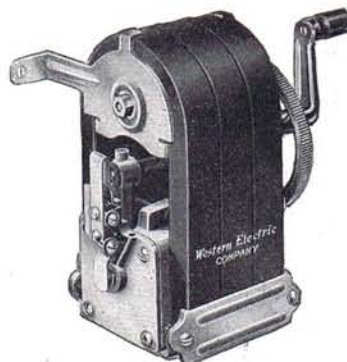

No. 50A

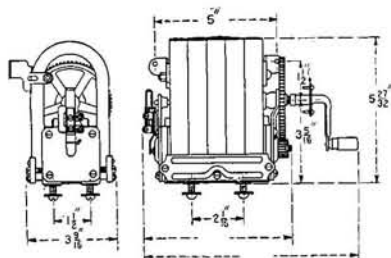

No. 48 Type Generator

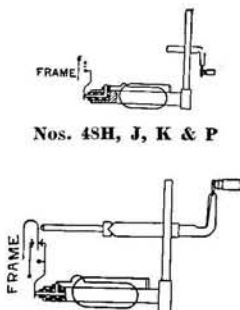

Nos. 48H, J, K & P

No. 50A
Schematics of Generator Circuits

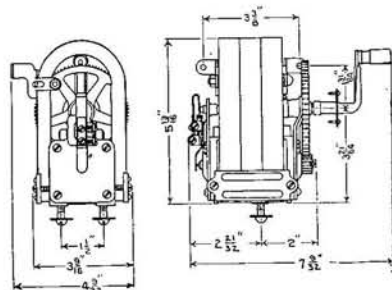

No. 50 Type Generator

NO. 48 TYPE GENERATORS

The No. 48 Type is our most powerful Hand Generator and is used in telephones for heavily loaded line service.

With a non-inductive load of 1,500 ohms and an armature speed of 1025 R.P.M., these Generators will give 80 volts A.C. No. 48B also gives 56 volts positive and negative pulsating current under the same conditions.

Code No.	Voltage	Normal Condition of Generator Circuit	Principal Use and Description
48A	80 A.C.	Open	Standard for telephones intended for use on heavily loaded lines. Telephones designed for "secret" signalling.
48B	80 A.C. & 56 P.C.	Open	
48C	80 A.C.	Open	Mine telephones. All parts are treated to resist the action of moisture and fumes.
48H	80 A.C.	Closed	Switchboards.

NO. 50 TYPE GENERATORS

The No. 50 Type delivers 60 volts A.C. under a 1,500 ohm non-inductive load (after being short-circuited for 1/2 minute) and an armature speed of 1025 R.P.M.

Code No.	Voltage	Normal Condition of Generator Circuit	Principal Use and Description
50A	60 A.C.	Open	For telephones for use on medium loaded lines. Same as the 50A, except that a shorter crank is provided and the rear mounting bracket is omitted. Intended for use in telephones in which a mounting bracket forms a part of the telephone.
50F	60 A.C.	Open	

NO. 51 TYPE GENERATORS

The No. 51A Generator is similar to the 48C Generator, except that the contact springs are enclosed in a protective compartment.

Code No.	Voltage	Normal Condition of Generator Circuit	Principal Use and Description
51A	80 A.C.	Open	In 536E Subscriber Set in Mine Telephones. All parts are treated to resist moisture and fumes.

HAND GENERATOR REPLACEMENT PARTS

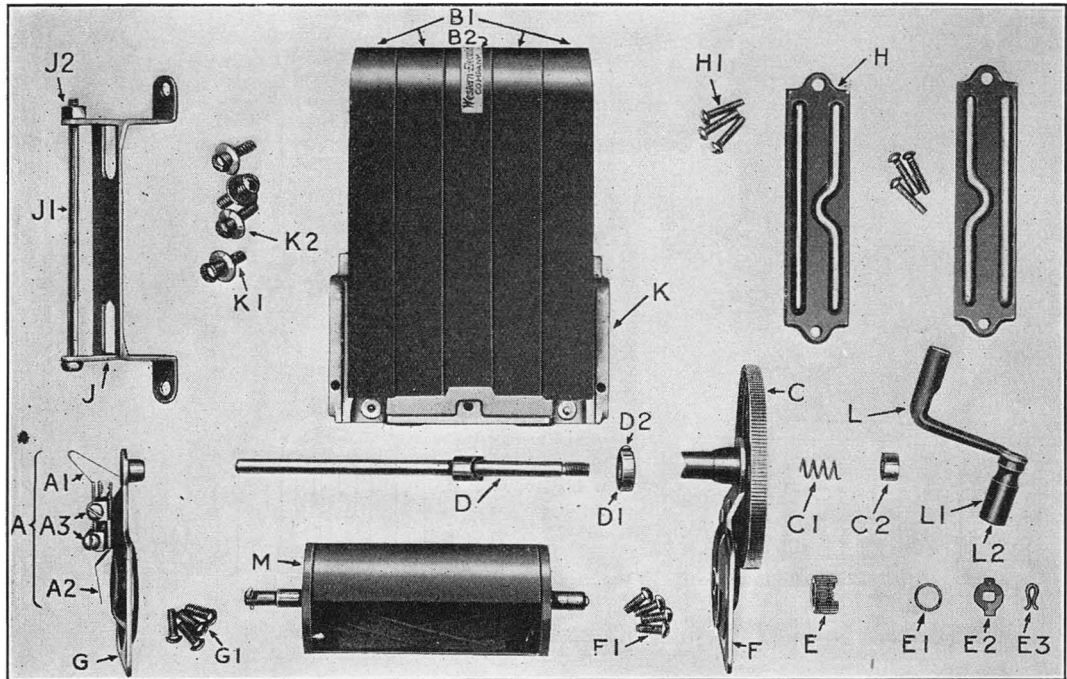

Part	Name of Part	22A	22D	22E	22K	22N	29B	29E	29F	48A	48B
A	Contact Spring Assembly	*	*	*	*	*	*	*	*	*	*
A-1	Shaft Contact Spring	P- 46968	P- 44597	P- 46968			P- 20800	P-113335	P-113335	P-101468	P-106102
A-2	Armature Contact Spring	P- 46969	P- 44596	P- 46969	P- 46969	P- 46969		P-122967	P-122967	P-103130	P-106099
A-3	But. H. M. Screw	P-122193	P-116353	P-122193	P-122193	P-122193		P-122982	P-106222	P-106222	P-106222
B-1	End Magnet	P- 18383	P- 18383	xP- 18383	P- 18383	P- 207127	xP- 21365	xP-128889	xP-121728	P-106117	P-106117
B-2	Center Magnet	P-136786	P-136786	†P-136786	P-136786	P-207128	†P-136787	†P-136789	†P-136788	P-136790	P-136790
C	Gear and Sleeve	P-139879	P-139885	†P-139879	P-139879	P-139883	P-139883	P-139891	P-139891	P-139889	P-139889
C-1	Main Shaft Spring	P-141097	P- 19671	P-141097			P- 10293	P-135611	P-135611	P- 18377	P- 18377
C-2	Shaft Nut or Coupling	P- 18378	P-139870	P- 18378			P- 19420	P-149750	P-101492	P-101492	P-101492
D	Shaft	P-139882	P-139860	P-139882			P- 19464	P-139862	P-139862	P-139864	P-139864
D-1	Shaft Nut or Collar	P- 18379	P- 20087	P- 18379	P- 18379	P- 18379	P- 18379	P-113451	P-113451	P-113451	P-113451
D-2	Shaft Collar Screw							P-138680	P-138681	P- 21140	P- 21140
E	Pinion	P- 21624	P- 21624	P- 21624	P- 21624	P- 21624	P- 21624	P-122957	P-121699	P-101493	P-101493
E-1	Pinion Spring	P- 18375	P- 18375	P- 18375	P- 18375	P- 18375	P- 18375	P- 18375	P- 42972	P- 42972	P- 42972
E-2	Pinion Washer							P-122964	P-103717		
E-3	& Pinion Cap. Cotter pin or R. H. M. Screw	P- 21625	P- 21625	P- 21625	P- 21625	P- 21625	P- 21625	P-110666	P- 42977	P- 42977	P- 42977
F	Bearing Bracket	P- 18366	P- 18366	P- 18366	P- 18366	P- 18366	P- 18366	P-122979	P-108955	P-108254	P-108254
F-1	R. H. M. Screw	P- 18366	P- 18366	P- 18366	P- 18366	P- 18366	P- 18366	P-124481	P-131593	P-106290	P-106290
G	Bearing Bracket	P-146134	P-146134	P-146134	P-146134	P-146134	P-146134	P-124482	P- 41140	P- 41140	P- 41140
G-1	R. H. M. Screws	P-18367	P- 20094	P-18367	P-18367	P-18367	P- 20037	P-124480	P-131592	P-106289	P-106143
H	Clamping Plate	P-146134	P-146134	P-146134	P-146134	P-146134	P-146134	P-124483	P-124482	P- 41140	P- 41140
H-1	R. H. M. Screw	P- 5863	P- 5863	P- 5863	P- 5863	P- 5863	P-113358			P-111330	P-111330
J	Mt. Bracket	P- 41383	P- 41383	P- 41383	P- 41383	P- 41383	P- 46983			P- 30443	P- 30443
J-1	R. H. M. Screw								P-121710	P-121753	P-121753
J-2	Nut								P-121774	P- 42986	P- 42986
K	Pole Piece	P- 18414	P- 18414	P- 18414	P- 18414	P- 18414	P- 21364	P-140483	P-121771	P-101556	P-101556
K-1	Mounting Screw								P-131600	P-108260	P-108260
L	Lower	P- 22779	P- 22779	P- 22779	P- 22779	P- 22779	P- 48704			P- 22779	P- 22779
L-1	Upper	P- 14943	P- 14943	P- 14943	P- 14943	P- 14943	P- 48703				
M	Washer	P-131379	P-131379	P-131379	P-18680	P-18680				P-131379	P-131379
L	Crank Assembly	P-158949	P-158949	P-158949	P-158946	P-158946	P-143244	P-135306	P-143244	P-158950	P-158950
L-1	Crank Handle	P- 18372	P- 18372	P- 18372	P- 18372	P- 18372	P- 18372	P- 18372	P- 18372	P- 18372	P- 18372
M	Armature	P- 44621	P- 44625	P- 44621	P- 44621	P- 44629	P- 44712	P-121693	P-121693	P-156430	P-156430

x These are left-hand magnets.

† These are right-hand magnets.

* Order as follows: Example: 1 Contact Spring Assembly for No. 48A Generator.

HAND GENERATOR AND BOXES

Hand Generator Replacement Parts (Continued)

Part	Name of Part	48C	48G	48H	48J	48K	48P	48R	48S	50A & F	51A
A	Contact Spring Assembly.....	*	*	*	*	*	*	*	*	*	*
A-1	Shaft Contact Spring.....	P-101468	P-101468	P-101468	P-101468	P-101468	P-217635
A-2	Armature Contact Spring.....	P-103130	P-103130	P-103130	P-103130	P-103130	P-103130	P-103130	P-103130	P-103130	P-217631
A-3	But. H. M. Screw.....	P-106222	P-106222	P-106222	P-106222	P-106222	P-106222	P-106222	P-106222	P-106222	P-121833
B-1	End Magnet.....	P-107912	P-106117	P-106117	P-106117	P-106117	P-106117	P-106117	P-107912	P-106117	P-106117
B-2	Center Magnet.....	P-136791	P-136790	P-136790	P-136790	P-136790	P-136790	P-136790	P-136791	P-136793	P-136790
C	Gear and Sleeve.....	P-139889	P-139889	P-139900	P-139900	P-139900	P-139900	P-139889	P-139889	P-139889	P-139889
C-1	Main Shaft Spring.....	P- 18377	P- 18377	P- 18377	P- 18377	P-141097	P- 18377
C-2	Shaft Nut or Coupling.....	P-101492	P-101492	P-158815	P-158815	P-101492	P-101492
D	Shaft.....	P-139864	P-139864	P-139874	P-139874	P-139866	P-139864
D-1	Shaft Nut or Collar.....	P-113451	P-113451	P-113451	P-113451	P-113451	P-113451
D-2	Shaft Collar Screw.....	P- 21140	P- 21140	P- 21140	P- 21140	P- 21140	P- 21140
E	Pinion.....	P-101493	P-101493	P-101493	P-101493	P-101493	P-101493	P-101493	P-101493	P-101493	P-101493
E-1	Pinion Spring.....	P- 42972	P- 42972	P- 42972	P- 42972	P- 42972	P- 42972	P- 42972	P- 42972	P- 42972	P- 42972
E-2	Pinion Washer and Pinion Cap.....	P-107916	P- 42977	P- 42977	P- 42977	P- 42977	P- 42977	P- 42977	P-107916	P- 42977	P-107916
E-3	Cotter pin or R. H. M. Screw.....	P-108254	P-108254	P-108254	P-108254	P-108254	P-108254	P-108254	P-108254	P-108254	P-108254
F	Bearing Bracket.....	P-106290	P-106290	P-103899	P-103899	P-122083	P-122083	P-106290	P-106290	P-106290	P-106290
F-1	R. H. M. Screws.....	P- 41140	P- 41140	P- 41140	P- 41140	P- 41140	P- 41140	P- 41140	P- 41140	P- 41140	P- 41140
G	Bearing Bracket.....	P-106143	P-106289	P-106289	P-103898	P-122085	P-122085	P-106289	P-106289	P-106289
G-1	R. H. M. Screws.....	P- 41140	P- 41140	P- 41140	P- 41140	P- 41140	P- 41140	P- 41140	P- 41140	P- 41140
H	Clamping Plate.....	P-107914	P-111330	P-111330	P-111330	P-111330	P-111330	P-111330	P-107914	P-113427	P-107914
H-1	R. H. M. Screw.....	P-107905	P- 30443	P- 30443	P- 30443	P- 30443	P- 30443	P- 30443	P-107905	P- 30443	P-107905
J	Mounting Bracket.....	P-106176	P-106840	P-106176	P-106176	P-106840
J-1	R. H. M. Screw.....	P-106177	P-106839	P-121753	P-106177	P-106177	P-106839	P-121753	P-121753	P-113428	P-121753
J-2	Nut.....	P-107906	P- 42986	P- 42986	P- 42986	P- 42986	P- 42986	P- 42986	P- 42986	P-113429	P-107906
K	Pole Piece.....	P-101556	P-101556	P-101556	P-101556	P-101556	P-101556	P-101556	P-101556	P-101556	P-101556
K-1	Mounting Screws.....	P-108261	P-108260	P-108260	P-108260	P-108260	P-108260	P-108260	P-108261	P-113410	P-108261
K-2	Washer.....	P-107908	P- 22779	P- 22779	P- 22779	P- 22779	P- 22779	P- 22779	P-131380	P- 22779	P-107908
L	Crank Assembly.....	P-131379	P-131379	P-131379	P-131379	P-131379	P-131379	P-131379	P-131379	P-131379	P-131379
L-1	Crank Handle.....	P-158948	P-158947	P-158947	P-158947	P-158947	P-131286	P-158950	P-158950	xP-158950	P-158950
M	Armature.....	P- 18372	P- 18372	P- 18372	P- 18372	P- 18372	P- 18372	P- 18372	P- 18372	P- 18372	P- 18372
		P-156431	P-156430	P-156430	P-156430	P-156430	P-156430	P-156430	P-156431	P-155522	P-156431

* Order as follows: Example: 1 Contact Spring Assembly for No. 48C Generator.
 † 50A P-113428 50F P-140909.
 x 50A P-158950 50F P-158949.

Hand Generator Boxes

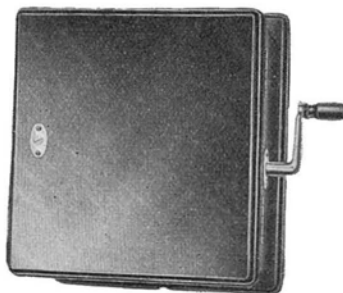

No. 299F

A hand generator box consists of a generator mounted in an oak cabinet having a hinged cover. The leads from the generator are connected to terminals mounted close to the inside edge of the box.

Code No.	Generator	Current	Dimensions of Box, Inches		
			Width	Depth	Length
299F	48A	Alternating.....	8	6	9
299G	48B	Alternating and pulsating.....	8	6	9
303G	50A	Alternating.....	6¾	5½	8⅞

HAND SETS

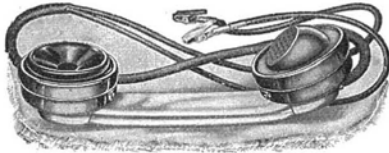

No. 1001A

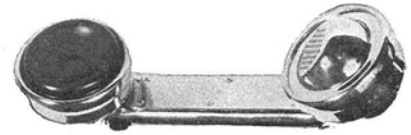

No. 1001C Hand Set

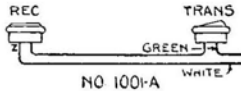

NO 1001-A

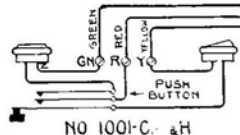

NO 1001-C & H

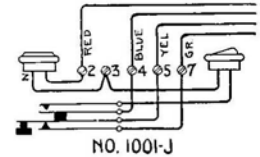

NO. 1001-J

No. 1001 Type

The No. 1001 Type Hand Sets were originally intended for the use of linemen and are designed to withstand the rough handling, incidental to such service. This design proved to be so satisfactory that it is now used extensively for a number of different purposes, as described below.

The handles are made of brass tubing with drawn brass end pieces and the transmitters and receivers are provided with drawn brass cases equipped with screw clamping rings, thereby making an instrument that is extremely rugged.

The Nos. 1001C and H Hand Sets are provided with a push button switch which is connected so that these hand sets function the same as the No. 1020AL Desk Stand. In view of this, they may be used in connection with our regular magneto and central battery desk set boxes in place of a desk stand, in cases where the service conditions are such that a hand set is required.

Code No.	Transmitter	Receiver	Cords		Push Button Spring Combination	Principal Use
			Code No.	Length		
1001A	244	131	243	8 ins.	None	Used by linemen as a test set on central battery lines. The cord is equipped with spring connection clips.
			2-574	5 ft.		
			(waterproof)			
1001C	285	131	366	6 ft.	2 make	Used with Nos. 1330 and 1331 Portable Magneto Telephones.
			(waterproof)			
1001H	244	131	422	5 ft. 2 ins.	2 make	Used with No. 1375B Portable Magneto Telephone.
			(waterproof)			
1001J	244	131	502	6 ft.	1 make and 1 break	Used with desk Interphones. No. 1 System.

Note 1. See "Hand Set Hangers" and No. 141A Switch Hook.

Note 2. Further data on above hand set transmitters and receivers are listed under their respective headings.

Note 3. For a hand set wired similar to the No. 1001A Type, but having a cut-out button, the Nos. 1001C or H Types may be used, making line connections by means of the green and yellow tracer conductors of the hand set cord only.

HAND SETS—Continued

No. 1002 Type

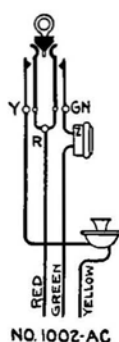
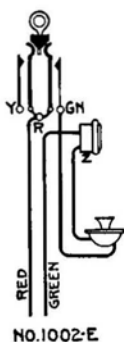
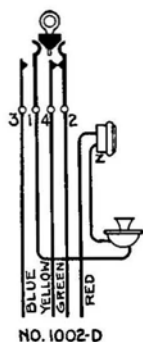

The transmitter and receiver of the No. 1002 Type Hand Sets are mounted on a nickel plated tubular brass frame, equipped with a hard rubber handle. A switch mounted within the frame, is actuated by a plunger which terminates in a ring by which the Hand Set is suspended, when not in use. When the Hand Set is removed from the hook, the switch is automatically closed. These Hand Sets function the same as certain desk stands, and may be used in place of desk stands if required. A hook (No. 141A Switchhook) is furnished with each Hand Set.

Code No.	Transmitter	Receiver	Code No.	Length	Cords		Code No.	Length	Switch Combination
					No.	Length			
1002D	267	141	336	14 ins.	414	8½ ins.	429	4 ft. 6 ins. (4 conductors)	1 make and 1 break
1002E	267	141	336	14 ins.	402	8½ ins.	430	4 ft. 6 ins. (2 conductors)	1 make contact
1002AC	267	141	415	9½ ins.	414	4¼ ins.	318	4 ft. (3 conductors)	2 make

“E” Type

The “E” Type Hand Sets listed below are finished in black. These Sets are also available, however, finished in ivory, gray, old brass, statuary bronze, oxidized silver, medium gold and dark gold. The dash (—) number part of the code indicates the color and should be specified on the order. Representative dash (—) numbers used to designate these colors are as follows:

Black.....	—3	Statuary Bronze.....	— 7
Ivory.....	—4	Oxidized Silver.....	— 8
Gray.....	—5	Medium Gold.....	—11
Old Brass.....	—6	Dark Gold.....	—12



E1B TYPE

The No. E1B Type Hand Set is intended for use with C1, D1 or similar type Handset Mountings as station Hand Telephone Sets.

Code No.	Transmitter	Receiver	Code	Cord Length	Hand Set Handle
E1B-3	395B-3	557B-3	*H3B9	4 ft.	E13

* If an E1B-3 Hand Set is desired equipped with a water-proof cord in place of the H3B9 cord, order should specify H3C water-proof cord.

E2A TYPE

The No. E2A Type Hand Set is intended for use in central offices and in P.B.X. systems.

Code No.	Transmitter	Receiver	Code	Cord Length	Equipped with Plug	Handset Handle
E2A-3	395B-3	557B-3	H4C	4 ft.	137	E23

HAND SETS—Continued**E2B TYPE**

The No. E2B Type Hand Set is a four conductor Hand Set intended for use on anti-sidetone local battery talking-common battery signaling subscriber sets in manual or dial systems. Forms a part of the 206 Type Hand Telephone Set.

Code No.	Transmitter	Receiver	Code	Cord	Length	Handset Handle
E2B-3	395B-3	574A-3	H4D9		4 ft.	E23

Handset Hangers

Code No.	Description
1B	Mounts on a vertical surface for holding a No. 1001 Type Hand Set when not in use. The Hand Set is suspended by its receiver, which fits into a recess in the hanger. Cast brass; black finish. Overall dimensions, $3\frac{1}{8}$ inches wide, $2\frac{1}{2}$ inches deep, and $3\frac{3}{8}$ inches high.
1C	Same as the No. 1B, except that it is equipped with rubber studs and a spring, so arranged as to prevent the Hand Set from swaying. Used principally on steamships.
4A	Black finished hook arranged for supporting an E1B or E2 Type Hand Set and a black finished bumper plate into which is fastened a linoleum pad. Intended to mount on the face of P.B.X. switchboards, order turrets, etc.
5A	Consists of a No. 4A Handset Hanger provided with a reversible mounting bracket. Intended to mount on either the right or left end panel of P.B.X. switchboards. Bumper plate must be mounted accordingly.

Handset Mountings

The following Handset Mountings are for use with E1B, E2B or similar type Hand Sets and form a part of the 200 Type Hand Telephone Sets listed elsewhere in this catalog.

The Handset Mountings described below are finished in black. They are available, however, in ivory, gray, old brass, statuary bronze, oxidized silver, medium gold and dark gold. The dash (—) number part of the code indicates the color and should be specified on the order. Representative dash (—) numbers used to designate these colors are as follows:

Black	—3	Statuary Bronze	—7
Ivory	—4	Oxidized Silver	—8
Gray	—5	Medium Gold	—11
Old Brass	—6	Dark Gold	—12

Handset Mountings—Continued

C1 TYPE

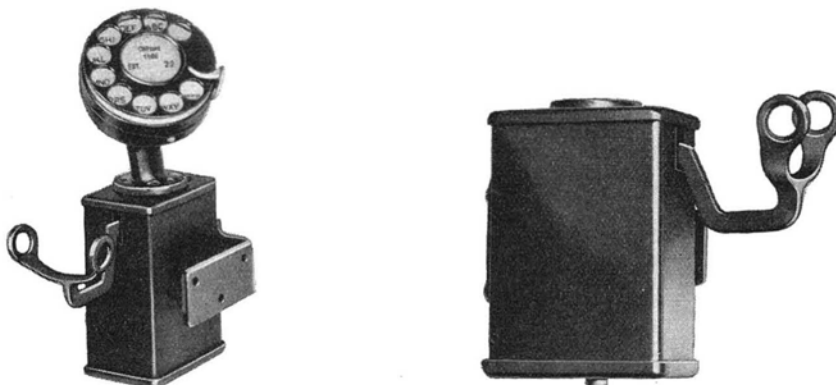

C1 Type Handset Mountings with and without dial

The C1 Type Handset Mounting is intended for use with the E1B Type Hand Set at anti-sidetone common battery manual or dial stations. Forms a part of the 201 Type Hand Telephone Set. It is used when it is desirable that the Mounting be attached to a vertical surface. (The hand set is suspended by its receiver.) Provided with an adjustable bracket by means of which it may be attached to either side of a desk.

The reversible mounting bracket is adjustable to four lengths:

$\frac{3}{16}$ " $\frac{1}{2}$ " $1\frac{3}{16}$ " or $1\frac{1}{8}$ "

C1-3 (black finished) Handset Mountings will be furnished unless otherwise specified.

D1 TYPE



D1 Type Handset Mounting (Dial Mounted)

The D1 Type Handset Mounting is intended for use with the E1B Type Hand Sets at anti-sidetone common battery manual or dial stations. Forms a part of the 202 Type Hand Telephone Set.

D1-3 (black finished) Handset Mountings will be furnished unless otherwise specified

HANDSET MOUNTINGS—Continued**D5 Type**

The D5 Type Handset Mounting is intended for use with the E2B Type Hand Set at anti-sidetone local battery talking-common battery signaling manual or dial stations. Forms a part of the 206 Type Hand Telephone Set.

D5-3 (black finished) Handset Mountings will be furnished unless otherwise specified.

D6 Type

The D6 Type Handset Mounting is intended for use with the E1B Type Hand Set at anti-sidetone, two-party selective message rate, party on tip stations in dial systems. Forms a part of the 203 Type Hand Telephone Set.

D6-3 (black finished) Handset Mountings will be furnished unless otherwise specified.

E4 Type

E4 Type Handset Mounting

The E4 Type Handset Mounting is intended for use with the E1B Type Hand Set in 750A Private Branch Exchange Systems.

E4-3 (black finished) Handset Mountings will be furnished unless otherwise specified.

HANDSET MOUNTINGS—Continued

Replacement Parts

C1 HANDSET MOUNTING

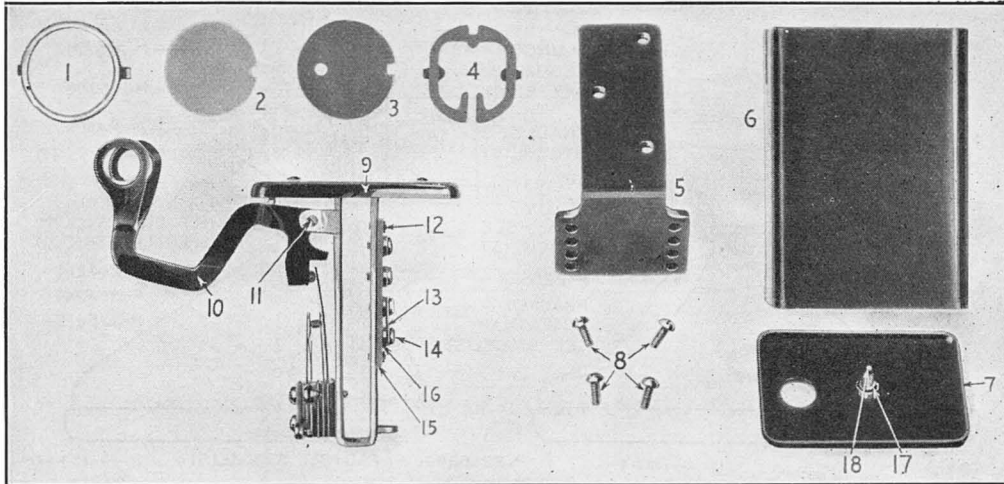

Parts List for C1 Handset Mounting

Part	Name	Part No.	Part	Name	Part No.
1	Card Holder Frame.....	P-220057	10	{ Switchhook.....	P-223587
2	Celluloid Window.....	P-137593		{ Rubber Stop.....	P-93377
3	Card Retainer.....	P-164442	11	Pin.....	P-223578
4	Reinforcing Ring.....	P-172045	12	.088" x 1/4" Long Tubular Rivet.....	
5	Bracket.....	P-223588	13	Strap.....	P-223595
6	Case.....	P-238829	14	Button H.M. Screw.....	P-146320
7	Bottom Plate.....	P-223586	15	Terminal Strip.....	P-223598
8	R.H.M. Screw.....	P-98663	16	Screw Bushing.....	P-204003
9	Cover and Terminal Plate Assembly...	P-290061	17	Spring.....	P-215578
			18	Fil. H.M. Screw.....	P-223580

Note: When the C1 Type Handset Mounting is used in manual systems the card holder illustrated in the cut is required, but not furnished unless specified. When used in dial systems one No. 39A dial mounting is required. This also is not furnished unless specified. For associated equipment for various classes of service, see "Hand Telephone Sets".

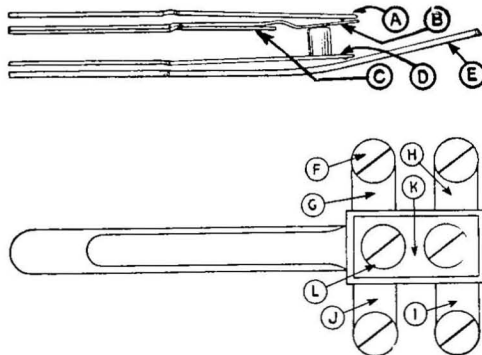

**SPRING ASSEMBLY FOR
C1 TYPE HANDSET MOUNTING**

Parts List for C1 Type Handset Mounting Spring Assembly

Part	Name	Part No.	Part	Name	Part No.
A	Contact Spring.....	P-223600	I	Terminal.....	P-223862
B	Contact Spring.....	P-223601	J	Terminal.....	P-223860
C	Contact Spring.....	P-223603	K	Clamping Plate.....	P-223576
D	Contact Spring.....	P-223602	L	R.H.M. Screw.....	P-118282
E	Contact Spring.....	P-223599		Rubber Bushing.....	P-223581
F	Button H.M. Screw.....	P-128913		Rubber Stud.....	P-223582
G	Terminal.....	P-223863		Insulator (3/16" thick).....	P-223574
H	Terminal.....	P-223861		Insulator (3/16" thick).....	P-223575

For complete Contact Spring Assembly specify P-290060.

HANDSET MOUNTINGS

Replacement Parts—Continued

D TYPE HANDSET MOUNTING

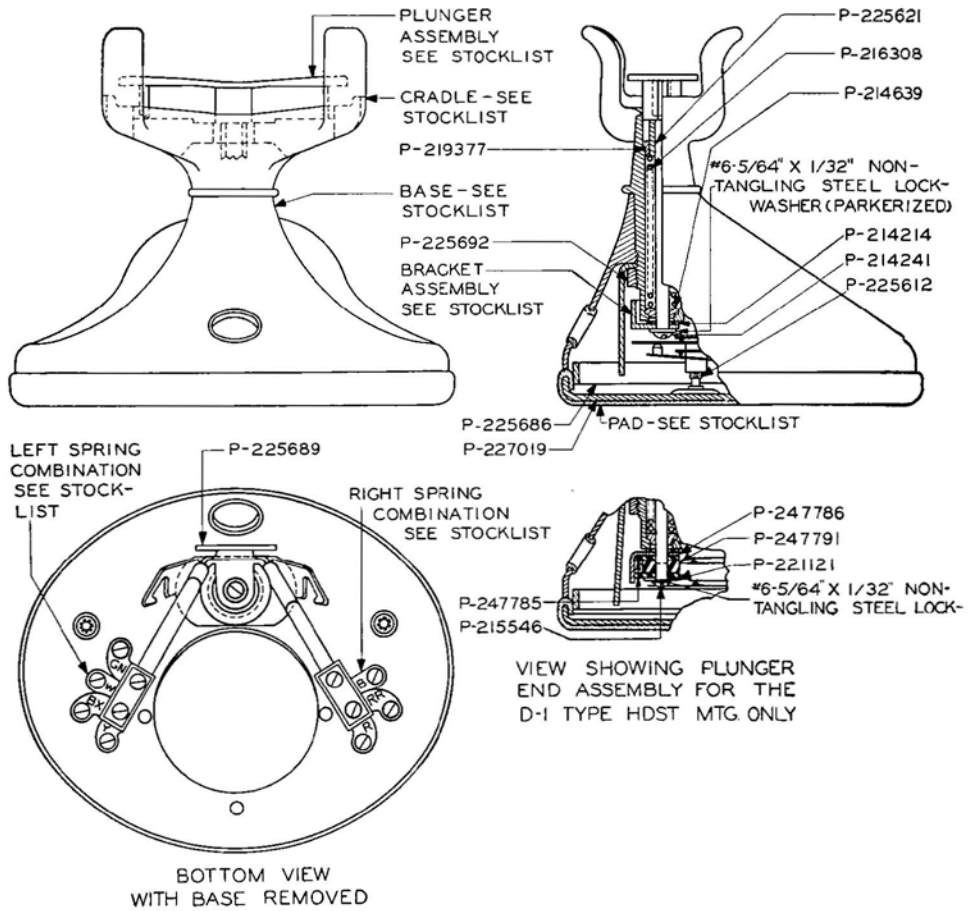

SPRING COMBINATIONS D-1 TYPE HANDSET MOUNTING

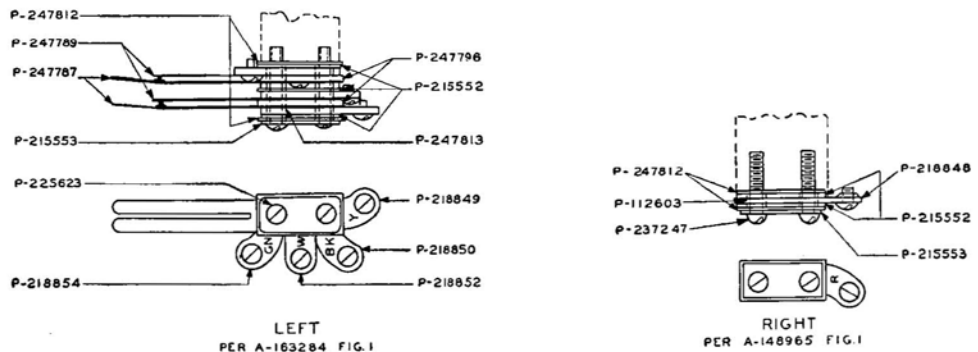

HANDSET MOUNTINGS

Replacement Parts—Continued

SPRING COMBINATIONS D5 TYPE HANDSET MOUNTING

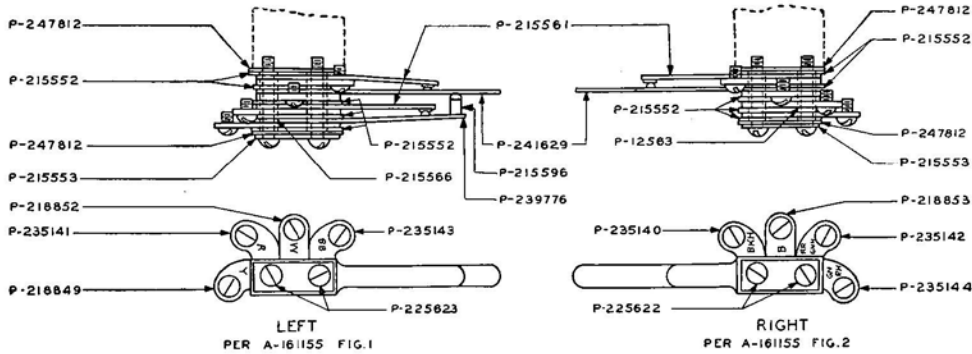

SPRING COMBINATIONS D6 TYPE HANDSET MOUNTING

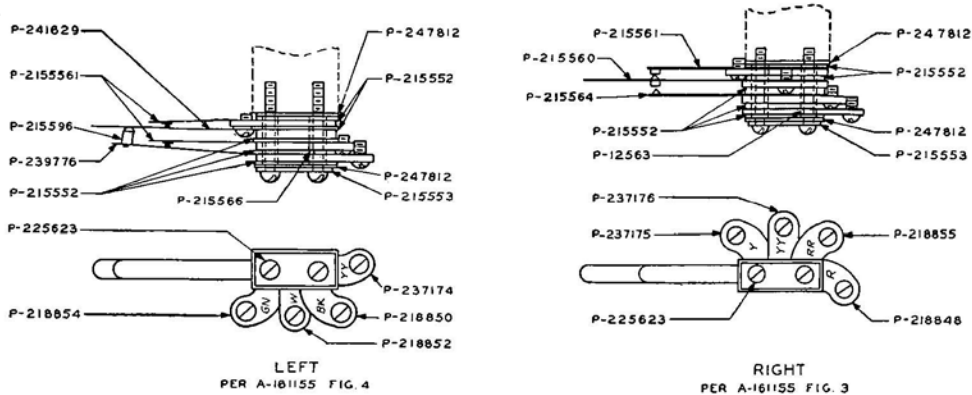

Parts list for "D" Type Handset Mountings

Name	D1-3		D5-3		D6-3	
	No. Reqd.	Piece Part	No. Reqd.	Piece Part	No. Reqd.	Piece Part
Button H.M. Screw	2	P-237247
Pad	1	P-236451	1	P-236451	1	P-236451
Cradle	1	P-233129	1	P-233129	1	P-233129
Base Plate	1	P-227019	1	P-227019	1	P-227019
Ring Nut	1	P-225692	1	P-225692	1	P-225692
Bracket	1	P-225689	1	P-225689	1	P-225689
Clamp	1	P-225686	1	P-225686	1	P-225686
Button H.M. Screw	2	P-225623	2	P-225623	4	P-225623
Button H.M. Screw	2	P-225622
Bushing	1	P-225621	1	P-225621	1	P-225621
Fil. H.M. Screw	2	P-225612	2	P-225612	2	P-225612
Bushing	1	P-219377	1	P-219377	1	P-219377
Spring	1	P-216308	1	P-216308	1	P-216308
Stop	1	P-215596	1	P-215596
Bushing	2	P-215566	2	P-215566
Contact Spring	3	P-215561	3	P-215561
Contact Spring	1	P-239776	1	P-239776
Insulator	5+	P-215552	10+	P-215552	10+	P-215552
Clamp Plate	2	P-215553	2	P-215553	2	P-215553
Bushing	1	P-214639	1	P-214639	1	P-214639
Button H.M. Screw	1	P-214241	1	P-214241
Washer	1	P-214214	1	P-214214	1	P-214214
Bushing	2	P-112603	2	P-12563	2	P-12563

HANDSET MOUNTINGS

Replacement Parts—Continued

Name	D1-3		D5-3		D6-3	
	No. Reqd.	Piece Part	No. Reqd.	Piece Part	No. Reqd.	Piece Part
Insulator.....	4	P-247812	4	P-247812	4	P-247812
Washer.....	1	P-221121
Base.....	1	P-224757	1	P-235160	1	P-236883
Plunger Assembly.....	1	P-239627	1	P-239627	1	P-239627
Operating Plate.....	2	P-247785
Bracket.....	1	P-247786
Contact Spring.....	2	P-247787	2	P-241629	1	P-215564
Contact Spring.....	2	P-247789	1	P-215560
Contact Spring.....	1	P-241629
Separator.....	1	P-247791
Insulator.....	2	P-247796
Button H.M. Screw.....	1	P-215546
Bushing.....	2	P-247813
Lock Washer (Parkerized).....	1	..	1	..	1	..
Terminal.....	1	P-218854	1	P-235144	1	P-237176
Terminal.....	1	P-218852	1	P-235143	1	P-237175
Terminal.....	1	P-218850	1	P-235142	1	P-237174
Terminal.....	1	P-218849	1	P-235141	1	P-218855
Terminal.....	1	P-218848	1	P-235140	1	P-218854
Terminal.....	1	P-218853	1	P-218852
Terminal.....	1	P-218852	1	P-218850
Terminal.....	1	P-218849	1	P-218848
Bracket.....	1	P-225688	1	P-225688
Base Plate Assembly.....	1	*P-290092	1	*P-290092	1	*P-290092

* This assembly is stocked as a spare part carried in Merchandise Stock.

For complete Left and Right Spring Assemblies specify as follows:

- D1 Type—Right Spring Combination—A-148965 Fig. 1
- D1 Type—Left Spring Combination—A-163284 Fig. 1
- D5 Type—Right Spring Combination—A-161155 Fig. 2
- D5 Type—Left Spring Combination—A-161155 Fig. 1
- D6 Type—Right Spring Combination—A-161155 Fig. 3
- D6 Type—Left Spring Combination—A-161155 Fig. 4

E4 TYPE HANDSET MOUNTINGS

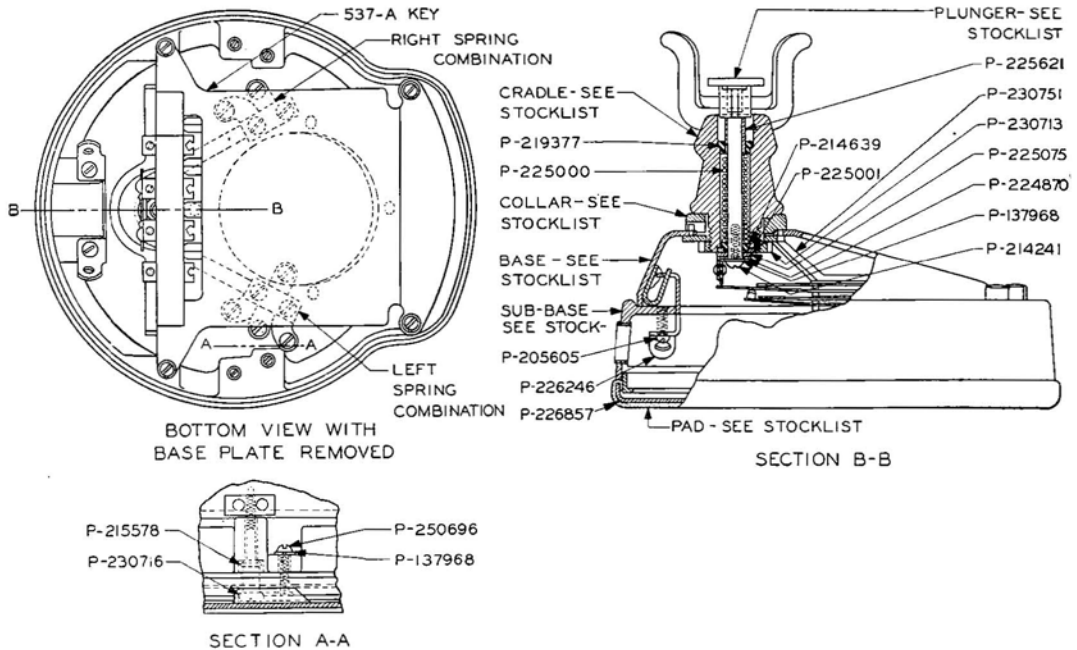

HANDSET MOUNTINGS

Replacement Parts—Continued

SPRING COMBINATIONS E-4 TYPE HANDSET MOUNTING

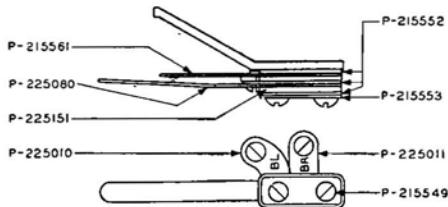

LEFT
PER A-148808 FIG. 1

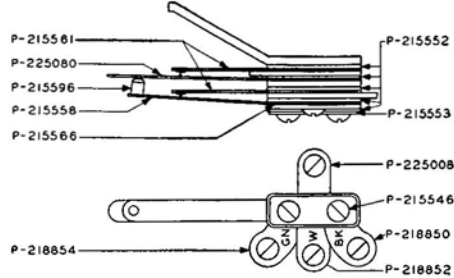

RIGHT
PER A-148808 FIG. 2

Parts List E4 Type Handset Mounting

E4-3			E4-3		
Name	No. Reqd.	Piece Part	Name	No. Reqd.	Piece Part
Pad.....	1	P-225266	Clamp.....	1	P-225084
Base.....	1	P-225017	Bushing.....	1	P-225621
Collar.....	1	P-224860	Hinge Bracket.....	1	P-226246
Cradle.....	1	P-224835	Mounting Bracket.....	1	P-230751
Base Plate Assembly.....	1	*P-290077	Bushing.....	1	P-219377
Spring.....	2	P-215578	Bushing.....	1	P-214639
R.H.M. Screw.....	2	P-250696	Washer.....	1	P-225075
Stud.....	1	P-215596	Lock Washer.....	3	P-137968
Base Plate.....	1	P-226857	Button H.M. Screw.....	1	P-214241
Ring Nut.....	1	P-230713	R.H.M. Screw.....	2	P-205605
Spring.....	1	P-225000	Circuit Label.....	1	P-244668
Washer.....	1	P-225901	Sub Base.....	1	P-231572
Contact Spring.....	2	P-225080	Plunger.....	1	P-226226
Contact Spring.....	3	P-215561	Terminal Assembly.....	1	P-218850
Contact Spring.....	1	P-215558	Terminal Assembly.....	1	P-218852
Insulator.....	8	P-215552	Terminal Assembly.....	i	P-218854
Bushing.....	2	P-215566	Terminal Assembly.....	1	P-225010
Bushing.....	2	P-225151	Terminal Assembly.....	1	P-225011
Clamping Plate.....	2	P-215553	Terminal Assembly.....	1	P-225008
Button H.M. Screw.....	2	P-215546	537-A Key.....	1	
Button H.M. Screw.....	2	P-215549	Bracket Assembly.....	1	P-224870
Fil. H.M. Screw.....	2	P-230716			

* This assembly is stocked as a spare part carried in Merchandise Stock.

For complete Right Spring Assembly specify A-148808 Fig. 1

For complete Left Spring Assembly specify A-148808 Fig. 2

HANDSET MOUNTING APPARATUS BLANKS

50H TYPE

The 50H Type Apparatus Blank is designed for use with "B" and "E" Type Handset Mountings when they are for use in manual service. Does not form a part of the Handset Mounting and must be ordered separately. Furnished in different finishes to correspond with Handset Mountings. Black finish furnished unless otherwise specified.

50J TYPE

The 50J Type Apparatus Blank is similar to the 50H Type except that it is designed for the "D" Type Handset Mounting.

HANDSET MOUNTINGS

Apparatus Blanks—Continued

REPLACEMENT PARTS

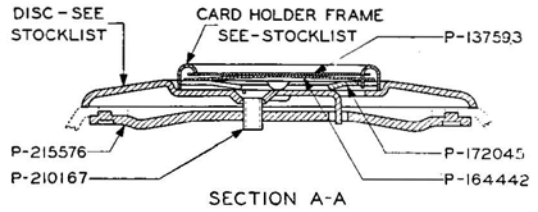
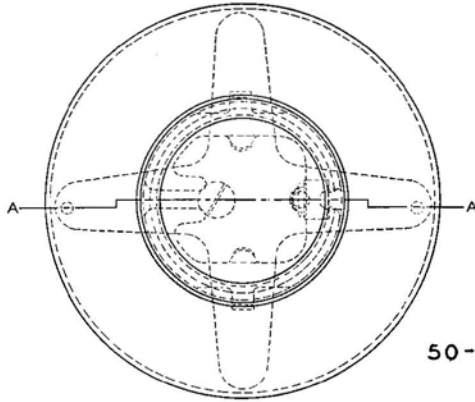

50-H APPARATUS BLANK

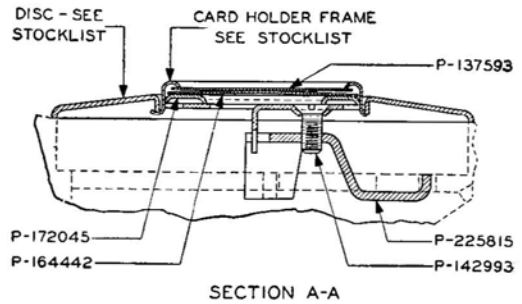
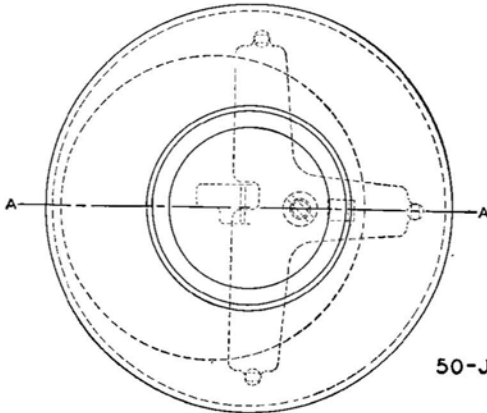

50-J APPARATUS BLANK

50H-3

50J-3

Name	No. Reqd.	Piece Part
Clamping Plate.....	1	P-215576
Disc.....	1	P-215591
F.H.M. Screw.....	1	P-210167
Card Holder Frame.....	1	P-220057
Reinforcing Ring.....	1	P-172045
Card Retainer.....	1	P-164442
Window.....	1	P-137593

Name	No. Reqd.	Piece Part
Clamping Plate.....	1	P-225815
Disc.....	1	P-225816
F.H.M. Screw.....	1	P-142993
Card Holder Frame.....	1	P-220057
Reinforcing Ring.....	1	P-172045
Card Retainer.....	1	P-164442
Window.....	1	P-137593

All parts listed black finished.

HAND TELEPHONE SETS



201A-3 Hand Telephone Set



202A-3 Hand Telephone Set



202B-3 Hand Telephone Set

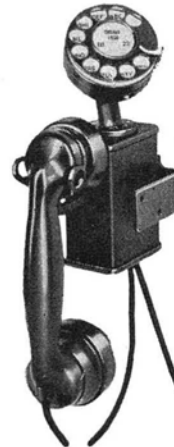

201B-3 Hand Telephone Set

The following Hand Telephone Sets are of the anti-sidetone type and are arranged for use with the anti-sidetone subscriber sets shown on pages 205 to 209. For information relative to water-proofed hand set cords associated with these Hand Telephone Sets, see "Hand Sets" pages 100 to 102.

All of the Hand Telephone Sets listed below are finished in black. These Sets are also available, however, finished in ivory, gray, old brass, statuary bronze, oxidized silver, medium gold and dark gold. The dash (—) number part of the code indicates the color and should be specified on the order. Representative dash (—) numbers used to designate these colors are as follows:

Black	—3	Statuary Bronze	—7
Ivory	—4	Oxidized Silver	—8
Gray	—5	Medium Gold	—11
Old Brass	—6	Dark Gold	—12

Example: If a 202B Hand Telephone Set with statuary bronze finish is desired, it should be ordered thus:

1—202B-7 Hand Telephone Set

HAND TELEPHONE SETS—Continued

NO. 201 TYPE

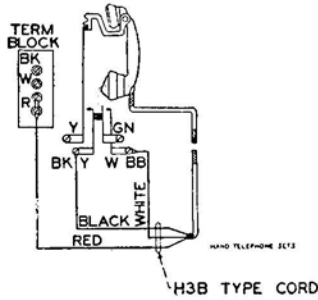

Manual Service
No. 201A

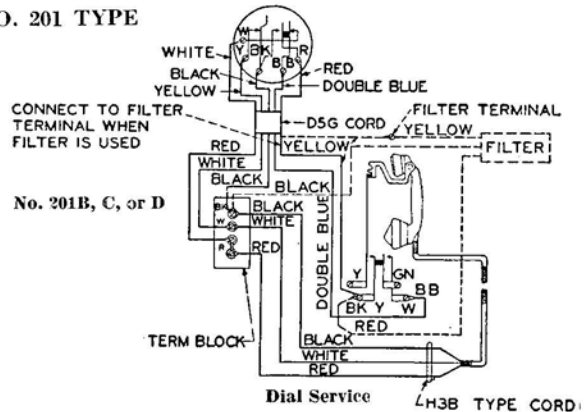

No. 201B, C, or D

Dial Service
H3B TYPE CORD

The No. 201 Type Hand Telephone Set is designed for general use at anti-sidetone common battery manual and dial stations.

The No. 201A is intended for use at manual stations.

The No. 201B, 201C and 201D Types are intended for use at dial stations. When specified in the order, these Sets will be furnished equipped with a No. 61G Filter to suppress dialing induction into radio receiving sets.

Code No.	Hand Set Mtg.	Dial No.	Consists of Dial Mtg.		Cords	Hand Set	Replaces
*201A-3	C1-3	—	—	—	—	E1B-3	101A-3
201B-3	C1-3	4HA-3	39A-3	—	D5G	E1B-3	101B-3
201C-3	C1-3	4HB-3	39A-3	—	D5G	E1B-3	101C-3
201D-3	C1-3	4HE-3	39A-3	—	D5G	E1B-3	101D-3

* Equipped with card holder.

NO. 202 TYPE

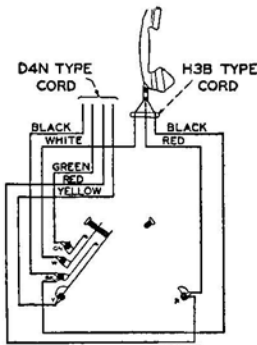

Manual Service

No. 202A

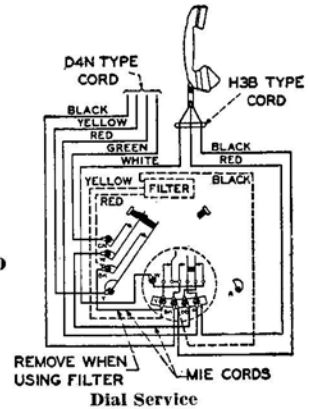

No. 202B, C, or D

The No. 202 Type Hand Telephone Set provides the same service as the 201 Type, the difference in the two types being in the handset mounting.

The No. 202A is intended for use in anti-sidetone common battery manual stations.

The Nos. 202B, 202C and 202D Types are intended for use in anti-sidetone common battery dial stations. When specified in the order these Hand Telephone Sets will be furnished equipped with a No. 61H Filter to suppress dialing induction into radio receiving sets.

Code No.	Hand Set Mtg.	Dial No.	App. Blank No.	Consists of		Hand Set	Recommended in Place of
202A-3	D1-3	—	50J-3	(a) Cords	†D4N-9	†E1B-3	102A-3
202B-3	D1-3	4HA-3	—	†One D4N-9	*Two MIE	†E1B-3	102B-3
202C-3	D1-3	4HB-3	—	†One D4N-9	*Two MIE	†E1B-3	102C-3
202D-3	D1-3	4HE-3	—	†One D4N-9	*Two MIE	†E1B-3	102D-3

* 5½ inches long.

† When specified in the order will be furnished equipped with a D4S water-proof cord instead of the D4N-9 cord. For information relative to water-proof hand set cords, see information on "Hand Sets".

(a) When specified in the order will be furnished equipped with a D4T type cord of corresponding color assembled with a No. 283A type plug (D4T-9 cord and No. 283A-3 plug furnished unless otherwise specified) instead of the corresponding D4N type cord.

HAND TELEPHONE SETS—Continued

NO. 203 TYPE

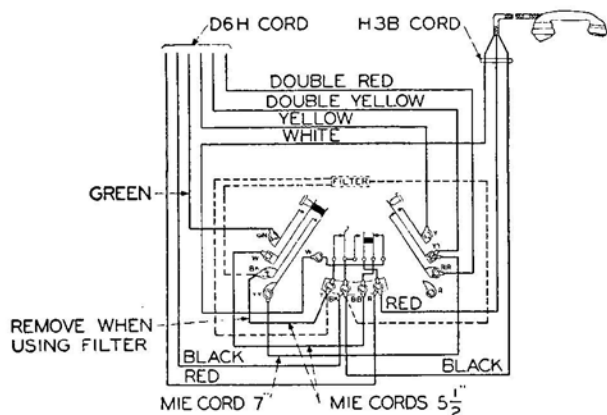

The No. 203 Type Hand Telephone Set is designed for use at anti-sidetone two-party selective message rate, party on tip stations in dial systems.

When specified in the order these Hand Telephone Sets will be furnished equipped with a No. 61H Filter to suppress dialing induction into radio receiving sets.

Code No.	Hand Set Mtg.	Dial No.	Consists of			Recommended in Place of
			Cords	Hand Set		
203A-3	D6-3	4HA-3	†One D6H-9	*Three M1E	E1B-3	103A-3
203B-3	D6-3	4HB-3	†One D6H-9	*Three M1E	E1B-3	103B-3
203C-3	D6-3	4HE-3	†One D6H-9	*Three M1E	E1B-3	103C-3

* One 7 inches long and two 5 1/2 inches long.

† When specified in the order will be furnished equipped with a D6J waterproof cord instead of the D6H-9 cord. For information relative to waterproof hand set cords, see information on "Hand Sets".

NO. 205 TYPE

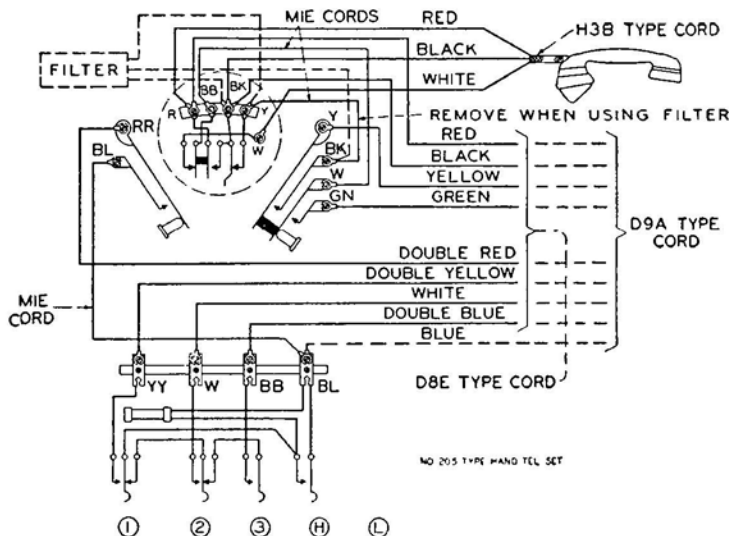

The No. 205 Type Hand Telephone Set is designed for use with anti-sidetone subscriber sets in No. 750A Private Branch Exchange systems.

When specified in the order these Hand Telephone Sets will be furnished equipped with a No. 61J Filter to suppress dialing induction into radio receiving sets.

The No. 205A, 205B and 205C Types are intended for use at key stations not arranged for routing central office trunk calls.

The No. 205D, 205E and 205F Types are intended for use at key stations arranged for routing central office trunk calls to and from keyless stations.

Code No.	Hand Set Mtg.	Dial No.	Consists of			Recommended in Place of
			†Cords	Hand Set		
205A-3	E4-3	4HA-3	One D8E-9	*Three M1E	E1B-3	105A-3
205B-3	E4-3	4HB-3	One D8E-9	*Three M1E	E1B-3	105B-3
205C-3	E4-3	4HE-3	One D8E-9	*Three M1E	E1B-3	105C-3
205D-3	E4-3	4HA-3	One D9A-9	*Three M1E	E1B-3	105D-3
205E-3	E4-3	4HB-3	One D9A-9	*Three M1E	E1B-3	105E-3
205F-3	E4-3	4HE-3	One D9A-9	*Three M1E	E1B-3	105F-3

* 5 1/2 inches long.

† When specified in the order will be furnished equipped with a D8F type cord of corresponding color assembled with a No. 274A type plug (274A-3 plug furnished unless otherwise specified) instead of the corresponding D8E type cord.

HAND TELEPHONE SETS—Continued

NO. 206 TYPE

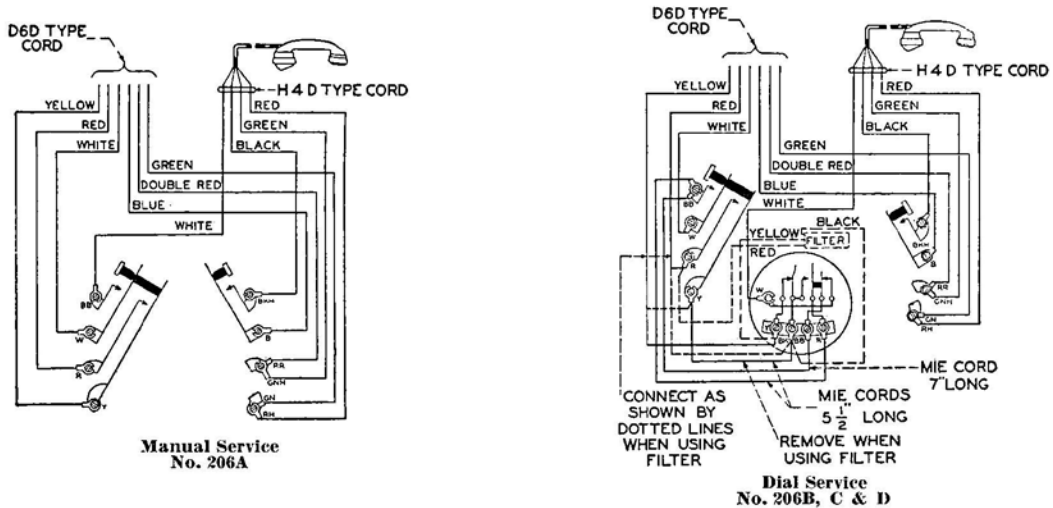

The No. 206 Type Hand Telephone Set is designed for use at anti-sidetone local battery talking-common battery signaling subscriber stations in manual or dial systems.

The No. 206A Type is intended for use in manual systems.

The No. 206B, 206C and 206D Types are intended for use in dial systems. When specified in the order these Sets will be furnished equipped with a No. 61H Filter to suppress dialing induction into radio receiving sets.

Code No.	Hand Set Mtg.	Dial No.	App. Blank No.	Consists of		Hand Set
				Cords		
206A-3	D5-3	—	50J-3	D6D-9		E2B-3
206B-3	D5-3	4HA-3	—	D6D-9	*Three M1E	E2B-3
206C-3	D5-3	4HB-3	—	D6D-9	*Three M1E	E2B-3
206D-3	D5-3	4HE-3	—	D6D-9	*Three M1E	E2B-3

* One 7 inches long and two 5½ inches long.

Head Bands (Receivers)

Code No.	Description
1B	Consists of a wire Head Band with olive drab textile covering, equipped with adjustable yokes for holding two No. 528 Receivers (less the No. 11A Head Band ordinarily furnished), also for holding two No. 509 Receivers.
1C	Similar to No. 1B. Intended for use with two No. 128W Receivers or 1010A or B Headsets (565A and B Receivers).
3D	Imitation leather covered wire Head Band of flat cross section for use with a single receiver in train dispatching service. Used in place of No. 3A Head Band with No. 528 Receiver in conjunction with No. 52AB Desk Stand. Recommended in place of No. 7A.
11A	A single wire Head Band arranged to hold one No. 128 or No. 528 Receiver. Made of one piece nickel finished piano wire. A No. 1466 Pad is furnished as part of this Head Band but is not assembled to it. Replaces the No. 3A Head Band.

HEAT COILS AND HOWLERS

Heat Coils

NO. 76 TYPE



No. 76A Heat Coil



No. 40 Type Heat Coil

The No. 76A Heat Coil is used in the No. 1168 Type, No. 1169A, No. 1268 Type and No. 1269A Protectors and in the Nos. 1435P, 1435H and 1435T Protector Groups for protecting central office equipment against sneak currents. It consists of a black hard rubber shell. When a current greater than that for which it is designed passes through the winding, the solder melts and allows a spring on the protector mounting to press the pin against a contact, thus grounding the line. Replaces No. 73A.

Code No.	Approx. Resistance	Will Operate in 210 Sec. on Amperes	For Use As
40	Brass Dummy
72A	Composition Dummy
76A	3.45 ohms	.54	Heat Coil

NO. 74 TYPE



No. 74 Type Heat Coil

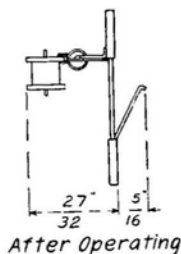
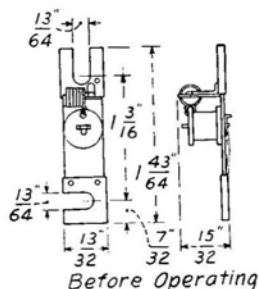

NO. 74-B,D,E&G

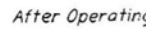
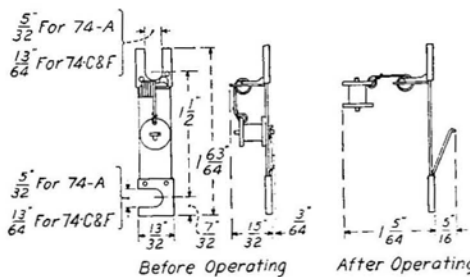

NO. 74-A,C&F

These heat coils are designed to act on small current values at which fuses will not give reliable operation. They are similar in mechanical construction to the No. 35 Type Fuses, differing in that a heat coil is used in place of a fuse wire. The spool of the coil is soldered to the alarm spring with low melting solder and the indicator spring is hooked into a hole in the upper spoolhead. When excessive current passes through the winding, the heat generated melts the solder, allowing the alarm spring to actuate the alarm and the indicator spring causes the spool to fly up, thereby giving a visible indication of the operated coil.

Fuse posts may be used in mounting the No. 74 Type Heat Coils. They will carry continuously one half their operating current.

Code No.	Rated Resistance		Will Operate in 210 Sec. On Current of (Amperes)	Size of Mounting Screw Required
	Max.	Min.		
74A	21.0	19.0	.18	No. 6
74B	4.1	3.7	.40	No. 10
74C	8.0	6.5	.265	No. 10
74D	4.7	4.4	.34	No. 10
74E	8.0	6.5	.265	No. 10
74G	57	53	.110	No. 10

Howlers

NO. 1 TYPE

The No. 1C Howlers are equipped with a bi-polar magnet structure of the same general construction as in Western Electric receivers. They are wound to 1,000 ohms resistance. The diaphragm of the howler may be accurately adjusted in relation to the pole pieces by rotating the front half of the case. When the correct position is obtained the case may be locked in position by means of a ring nut. For Morse calling in signal circuit.

Code No.	Description	Overall Dimensions, Ins.
1C	Mounted on a wooden base	6 1/4 x 6 x 3 15/16



No. 1C Howler

INDUCTION COILS

Western Electric Induction Coils are designed to obtain extremely high transmission efficiency. One of the important features is that the entire winding is included in the effective flux area. In other words, the entire winding is contributed to the efficiency of the Induction Coil; there being no dead sections of the winding to reduce its efficiency through the introduction of direct current resistance.

As a result of several years' research work, we have adopted a new core material which consists of a special steel alloy, used in the form of thin strips. This new material permits of greater transmission efficiency than was heretofore possible with any Induction Coil core material known to the telephone art.

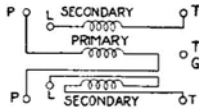
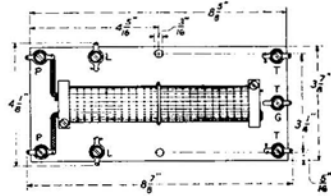

No. 10

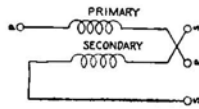

No. 13

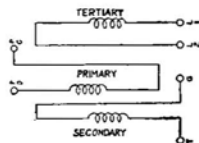
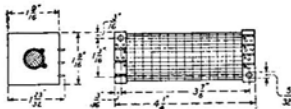

No. 23

Code No.	Description	Resistance (Ohms)			
		Primary	Secondary	Tertiary	
10	Intended for use in local and toll magneto switchboards.	(P-P)	.41 (L-T)	85.5	—

13	Intended for use in local battery subscriber sets	(P-P)	1.4 (S-S)	17.0	—
----	---	-------	-----------	------	---

23	Intended for use in Nos. 9 and 10 common battery switchboards and associated desks and Nos. 1 and 4 private branch switchboards and magneto switchboards.	(PC-PD)10.0 (T-G)	57.3 (L1-L2)	230.0	—
----	---	-------------------	--------------	-------	---

INDUCTION COILS—Continued

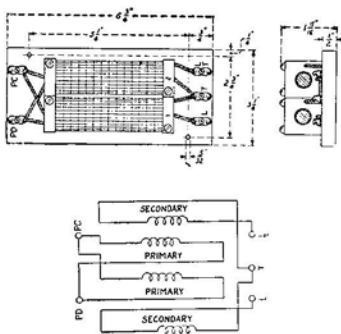
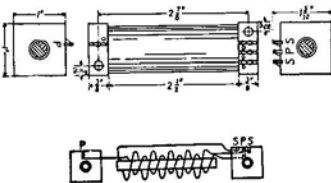
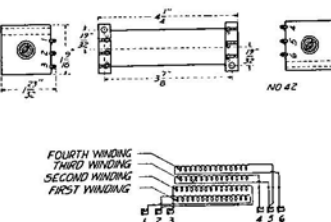
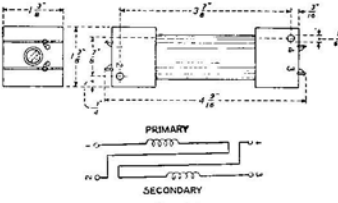
Code No.	Description	Resistance (Ohms)		
		Primary	Secondary	Tertiary
 <p>No. 24</p>	<p>24 Intended for use in No. 1 common battery switchboards and Nos. 1 and 2 toll switchboards and associated desks. Consists of two Induction Coils mounted side by side on a wooden base together with five terminals....</p>	(PC-PD) 8.2	(L-T)125.0 (T-LT)475.0	—
<p>31 Same as No. 13 except that it is treated to resist the action of moisture and fumes. Intended for use in Nos. 1336 and 1536 Type Mine Telephones.....</p>	(P-P) 1.4	(S-S) 17.0	—	
 <p>No. 32</p>	<p>32 Intended for use in magneto portable telephone sets and magneto Railway Train Dispatching Telephone Sets exposed to moisture or to weather. Used in No. 1526B Telephone Sets...</p>	(P-P) 0.38	(S-S) 37.0	—
 <p>No. 42</p>	<p>42 Designed for use in Nos. 501 A and 501B Desk Set Boxes and No. 1317 B U Telephone Sets.....</p>	First Winding	(1-2) .41 ohms	
		Second Winding	(2-3) 7.5 ohms	
		Third Winding	(4-5) 31.0 ohms	
		Fourth Winding	(5-6) 290.0 ohms	
 <p>No. 46</p>	<p>46 For use in common battery subscriber sets and in No. 506 type switchboards.</p>	(1-2) 14.7	(3-4) 9.5	—

INDUCTION COILS—Continued

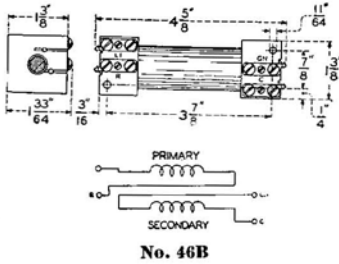

No. 46B

Code No.	Description	Resistance (Ohms)		
		Primary	Secondary	Tertiary
46B	Intended for use in common battery subscriber sets....	(L1-R) 14.7	(GN-C) 9.5	—

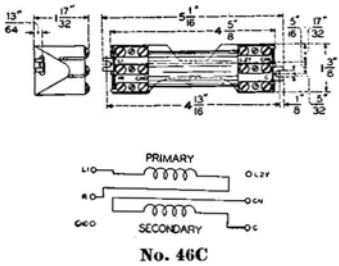

No. 46C

46C	Intended for use in No. 584 Type Subscriber Sets.....	(L1-R) 14.7	(GN-C) 9.5	—
-----	---	-------------	------------	---

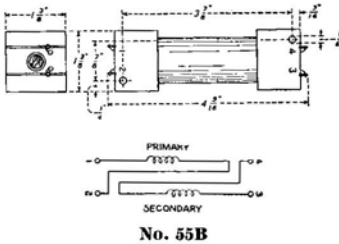

No. 55B

55B	Moisture-proofed Induction Coil. For use in subscriber sets. Recommended in place of No. 55...	(L1-R) 14.7	(GN-C) 9.5	—
-----	--	-------------	------------	---

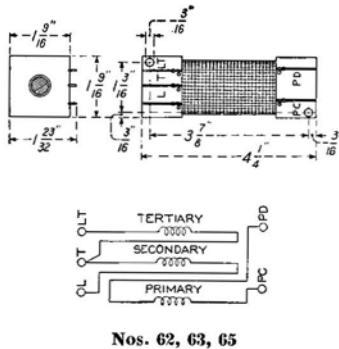

Nos. 62, 63, 65

62	Intended for use in "A" operator's anti-sidetone telephone circuit and "B" operator's telephone circuit.	(PC-PD)1.32	(L-T) 8.8	(T-LT) 325.0
63	Intended for use in P.B.X. attendant's anti-sidetone telephone circuit and "A" operator's telephone circuit.	(PC-PD) 2.3	(L-T) 25.0	(T-LT)450.0
65	Intended for use in toll operator's anti-sidetone telephone circuit and "B" operator's telephone circuit....	(PC-PD)1.32	(L-T) 9.9	(T-LT)500.0

INDUCTION COILS—Continued

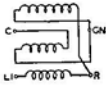
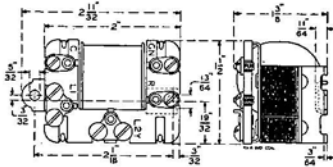

No. 101

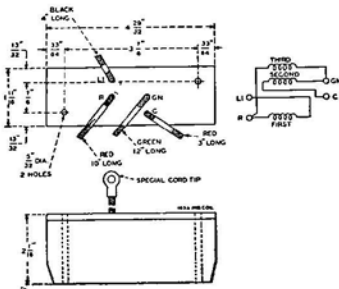

No. 103A

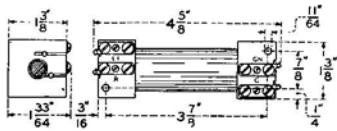

No. 146B

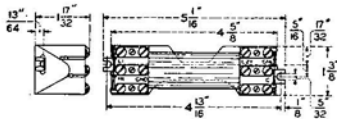

No. 146C

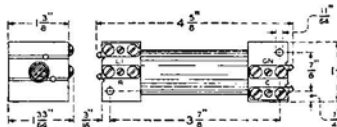

No. 155B

Code No.	Description	Resistance (Ohms)		
		Primary	Secondary	Tertiary
101	Intended for use in anti-sidetone subscriber sets.....	(L1-R) 22.0	(GN-C) 19.0	(R-GN) 75.0

103A	Potted anti-sidetone coil. Intended for use in 629A subscriber set. Electrically the same as the 146B coil.....	(L1-R) 14.7	(GN-C) 9.5	(GN-R) 53.5
------	---	-------------	------------	-------------

146B	Intended for use in anti-sidetone common battery subscriber sets.....	(L1-R) 14.7	(GN-C) 9.5	(GN-R) 53.5
------	---	-------------	------------	-------------

146C	Intended for use in anti-sidetone common battery subscriber sets.....	(L1-R) 14.7	(GN-C) 9.5	(GN-R) 53.5
------	---	-------------	------------	-------------

155B	Moisture resisting Induction Coil. Intended for use in anti-sidetone subscriber sets.....	(L1-R) 14.7	(GN-C) 9.5	(GN-R) 53.5
------	---	-------------	------------	-------------

INTERRUPTERS (Pole Changers)

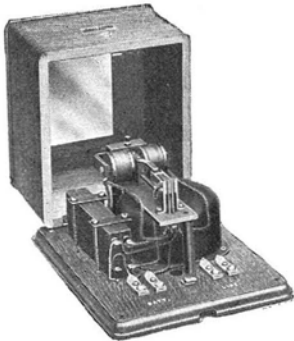

No. 62A Open

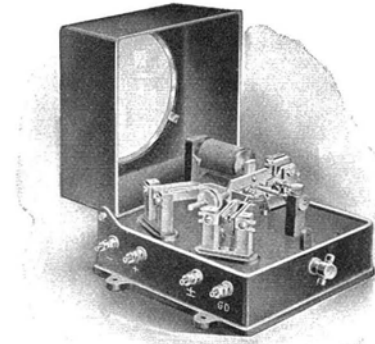

No. 84J Open

The Western Electric Interrupters listed below are suitable for private branch exchange service and for use with magneto switchboards and central battery equipments. They are a convenient means of obtaining alternating or pulsating current, or both, from a direct current source of energy.

The types and the various models differ in mechanical construction and circuit arrangement to suit (a) the source of current used to drive the vibrating element; (b) the source of energy used for producing ringing current and (c) the kind of current output necessary for ringing. These three points are covered in the description of each model. The Interrupters may be mounted horizontally or vertically.

NO. 62A TYPE

This is a ringing transformer or Interrupter for furnishing alternating ringing current. All the current needed for operating the Interrupter and for ringing is supplied by a single battery of from four to eight dry cells. The alternating current is of approximately forty volts.

The outfit is designed for ringing a small number of telephone bells on a low resistance line and is suited to private branch exchange service such as is required in connection with the No. 1801 P.B.X. Switchboard when serving a number of stations in the same building.

This Interrupter starts quickly, and is therefore adapted for code ringing. As it operates only when a push button or local contact on a ringing key is closed, it is economical, requiring energy only while actually ringing.

NO. 84 TYPE

No. 84 Type Interrupters act as electrically operated Pole Changers, producing alternating current for ringing purposes from a source of direct current. They have been thoroughly tested by wide application and extended service in the operating field.

The Nos. 84F and 84G Interrupters are for use in central battery offices. The Nos. 84H and 84J are designed for magneto exchanges.

Each No. 84 Type Interrupter is mounted on the top of a metal case, 8 inches square at the base, in which the condensers, resistances, and a switching key for starting and stopping the machine are mounted. A metal cover with a glass window is hinged on this case and protects the moving parts. A circuit label is pasted on the inside of the cover. These Interrupters occupy a small amount of space, are easy to install, have their adjustable parts readily accessible, and require a minimum amount of maintenance.

The following is a short description of the three Interrupters most generally used.

Code No.	
84F	Designed to operate from a 24-volt storage battery. The ringing current is derived from a 100-volt battery of dry cells. When used with a No. 56A Repeating Coil will produce approximately 95 volts A.C. for use with superimposed ringing and approximately 100 volts for A.C. ringing. Interrupter Springs equipped with platinum and tungsten contacts.
84H	The operating coil is wound for current from an Edison Type S-502 cell. Dry cells are used for supplying ringing current which is alternating only, at 85 volts, when a 100-volt dry cell battery is used. Interrupter Springs equipped with platinum and platinum iridium contacts. Recommended for use in place of the No. 84D.
84J	Designed to operate from an operating coil wound for two cells of Edison Type S-502 batteries. With a ringing battery of 100 volts, produces 56 volts positive and negative pulsating and 80 volts alternating current. Interrupter Springs equipped with platinum and platinum iridium contacts. Recommended for use in place of the No. 84E.

NO. 156B

The No. 156B Interrupter is intended for use in small offices with a source of 135 cycle current for ringing on toll lines; operates on 24-volt battery. Arranged to mount on 19" Relay Racks.

Consists of the following apparatus: 1 Vibrator with Platinum Contacts; 1 18K Resistance; 1 No. 57B Condenser; 1 No. 57AG Condenser; 1 No. 57H Condenser; 4 No. 57QF Condensers; 4 No. 57QH Condensers; 1 No. 71H Retardation Coil; 1 No. 71K Retardation Coil; 1 No. 71R Retardation Coil; 1 No. 84A Repeating Coil; 1 No. 149D Relay; 1 No. 159B Terminal Strip. A No. 91C Gauge is also furnished.

INTERRUPTERS—Continued

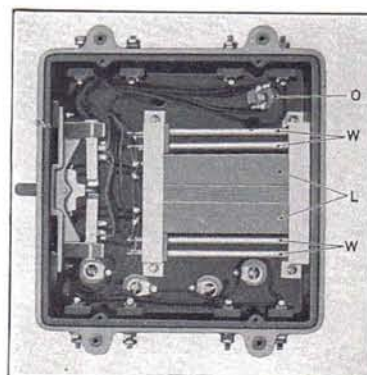
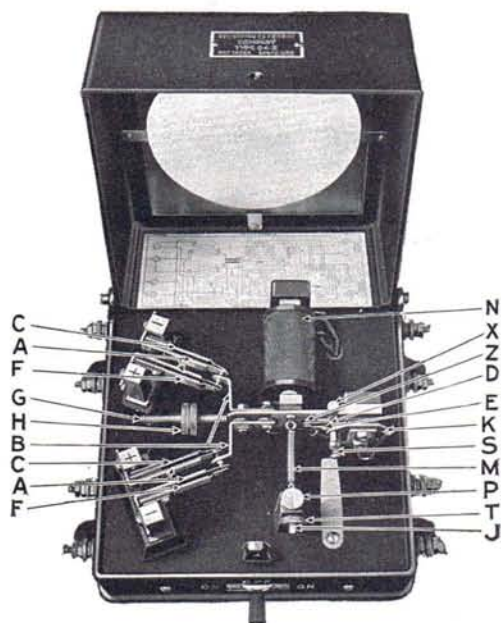

Bottom View

Types 84A, C, D, E, F, G, H and J Interrupters

PIECE PART LIST

When ordering give piece part number indicated in column under type of Interrupter for which new piece part is wanted.

Name	84A	84C	84D	84E	84F	84G	84H	84J
A Inner Ringing Spring.....	P- 46665	P- 46665	P-103970	P-106359	P-169848	P-169848	P-103970	P-106359
B Vibrator Arm.....	P- 46651	P- 46651	P- 46651	P- 46651	P-169847	P-169847	P-222397	P-222397
C Back Ringing Spring.....	P- 46667	P- 46667	P-106356	P-106356
D Inner Magnet Spring.....	P- 46668	P- 46668	P- 46668	P- 46668	P-119853	P-119853	P- 46668	P- 46668
E Outer Magnet Spring.....	P- 46669	P- 46669	P- 46669	P- 46669	P-119851	P-119851	P- 46669	P- 46669
F Front Ringing Spring.....	P- 46666	P- 46666	P-106358	P-106358
G Armature Arm.....	P- 46673	P- 46673	P-103975	P- 46673	P-119865	P-119865	P-222396	P-222396
H Weight Nut.....	P- 46650	P- 46650	P-103972	P-103972	P- 46650	P- 46650	P-222391	P- 46650
J Spiral Spring Adjusting Screw	P- 46648	P- 46648	P- 46648	P- 46648	P- 46648	P- 46648
K Adjusting Plate (Assembly)...	P- 46656	P- 46656	P- 46656	P- 46656	P-237712	P-237712
L Condenser.....	No. 21J	No. 21J	No. 21J	No. 21J	No. 21E	No. 21E	No. 21J	No. 21J
M Spiral Spring.....	P-106011	P-106011	P-106011	P-106011	P-106011	P-106011
N Magnet Coils.....	P-132829	P-128185	P-133769	P-132828	P-132829	P-128185	P-133769	P-132828
O Resistance Across Contacts...	No. 21B	No. 21B	Spl. No. 21 P-103977	Spl. No. 21 A-38625	No. 21B	No. 21B	P-103977	Spl. No. 21 D- 11595
P Spring Adjusting Screw Lock Nut.....	P-123818	P-123818	P-123818	P-123818	P-123818	P-123818
R Stiffening Spring.....	P- 46620	P- 46620
S Magnet Spring Adjusting Screw.....	P- 39625	P- 39625	P- 39625	P- 39625	P- 39625	P- 39625	P- 39625	P- 39625
T Spring Adjusting Screw Nut...	P- 46649	P- 46649	P- 46649	P- 46649	P- 46649	P- 46649
U Contact Spring Adjusting Clamp.....	P-119819	P-119819
V Adjusting Clamp Screw.....	P-119856	P-119856
W Resistance in Series with Con- denser.....	No. 18AC	No. 18AC	No. 18AC	No. 18AC	No. 18AC	No. 18AC
X Pivot Screw.....	P- 46651	P- 46651	P- 46651	P- 46651	P- 46651	P- 46651
Y Reed.....	P-117480	P-117480
Z Bumper Pin.....	P- 48913	P- 48913	P- 48913	P- 48913	P-117489	P-117489

JACKS

Singly Mounted—Welded Frame Jacks

The following singly mounted, electrically welded frame type jacks replace the corresponding punched frame types as indicated in the code number listings. The terminals of the jacks are regularly arranged to accommodate two No. 19 B & S gauge wires unless otherwise specified. Mounting screws are furnished.

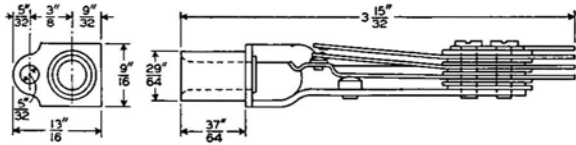

Fig. 1

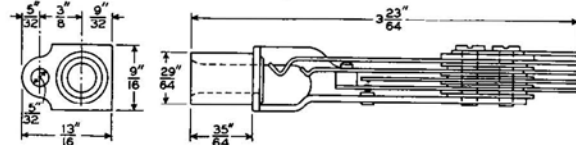

Fig. 2

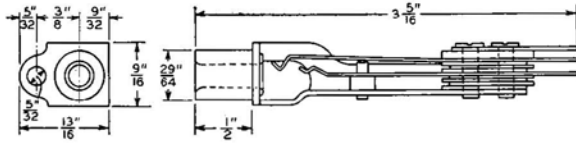

Fig. 3

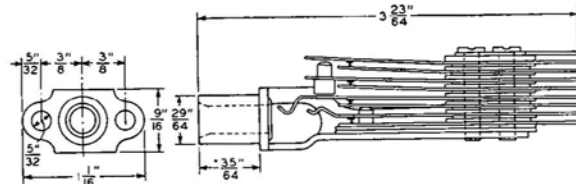

Fig. 4



No. 215 Jack

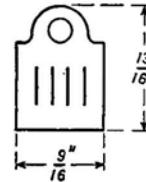

Fig. A

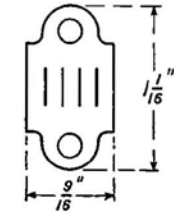
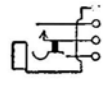
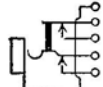

Fig. B



No. 215



No. 216

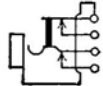

No. 217
220, 235

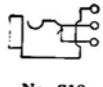

No. 218
219, 231



No. 221

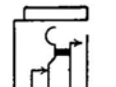

No. 225
No. 234



No. 226



No. 227



No. 230, 233



No. 232

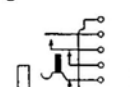

No. 236



No. 237



No. 240

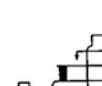

No. 241



No. 242



No. 243

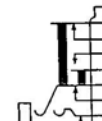

No. 245



No. 246, 238



No. 248, 239



No. 249



No. 267

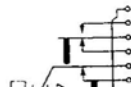

No. 280



No. 281

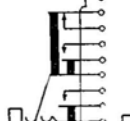

No. 284

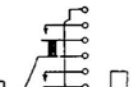

No. 285

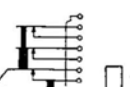

No. 289



No. 290



No. 291

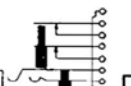

No. 293

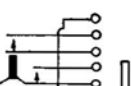

No. 297A



No. 300A

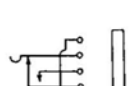

No. 303A

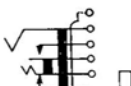

No. 360A



No. 361C



No. 387B & D

JACKS

Singly Mounted—Welded Frame—Continued

Code letters A, B, C and D of the code numbers of jacks listed below indicate the number of mounting lugs (single or double) and their arrangement with respect to the plane of the springs (horizontal or vertical) as illustrated in figures A, B, C and D on the preceding page.

JACKS FOR USE WITH PLUGS Nos. 47, 116, 137, 144, 151, 153D, 154, 217, 220, 221, 241 AND 246

Code No.	Dimen- sions Page 122 Fig. No.	Mounting Centers, Inches		Re- places Jack No.	Code No.	Dimen- sions Page 122 Fig. No.	Mounting Centers, Inches		Re- places Jack No.
		Horizontal	Vertical				Horizontal	Vertical	
(a) 215A	1	5/8	7/8	215	(h) 227C	2	5/8	*	206
(a) 215B	1	5/8	1 1/8	...	(j) 230A	1	5/8	7/8	...
(a) 215C	1	7/8	5/8	...	(j) 230C	1	7/8	5/8	146
(b) 216A	1	5/8	7/8	216	(j) 231A	1	5/8	7/8	...
(b) 216B	1	5/8	1 1/8	...	(j) 231B	1	5/8	1 1/8	...
(b) 216C	1	7/8	5/8	204	(j) 231C	1	7/8	5/8	147
(b) 217A	1	5/8	5/8	217	(j) 231D	1	1 1/8	5/8	168
(b) 217C	1	7/8	5/8	209	232A	1	5/8	7/8	...
(c) (b) 217E	1	5/8	7/8	...	232B	1	5/8	1 1/8	...
218A	1	5/8	7/8	218	232C	1	7/8	5/8	148
218B	1	5/8	1 1/8	...	232D	1	1 1/8	5/8	169
218C	1	7/8	5/8	...	(k) 232E	1	5/8	7/8	...
(d) 218E	1	5/8	7/8	...	233A	1	5/8	7/8	...
219A	1	5/8	7/8	219	233B	1	5/8	1 1/8	...
219B	1	5/8	1 1/8	...	233C	1	7/8	5/8	149
219C	1	7/8	5/8	155	233D	1	1 1/8	5/8	170
219D	1	1 1/8	5/8	175	(L) 234A	1	5/8	7/8	...
220A	1	5/8	7/8	220	(L) 234C	1	7/8	5/8	151
220C	1	7/8	5/8	154	(L) 234D	1	1 1/8	5/8	172
220D	1	1 1/8	5/8	176	(j) 235A	1	5/8	7/8	...
221A	1	5/8	7/8	221	(j) 235C	1	7/8	5/8	153
221B	1	5/8	1 1/8	...	(j) 235D	1	1 1/8	5/8	174
221C	1	7/8	5/8	152	236A	1	2 3/8	7/8	...
221D	1	1 1/8	5/8	173	(m) 236B	1	2 3/8	1 1/8	...
(e) 223A	1	5/8	7/8	223	236C	1	7/8	5/8	189
(e) 223B	1	5/8	1 1/8	...	236D	1	1 1/8	5/8	188
(f) 225A	1	5/8	*	225	237A	1	5/8	7/8	...
(f) 225B	1	5/8	1 1/8	...	237C	1	7/8	5/8	185
(f) 225C	1	5/8	*	156	(n) 281A	2	5/8	7/8	...
(f) 225D	1	5/8	1 1/8	177	(n) 297A	1	5/8	7/8	...
(g) (f) 225E	1	5/8	*	229A	303A	1	5/8	7/8	...
(a) 226A	1	5/8	*	226	(o) 303AK	1	5/8	7/8	...
(a) 226C	1	5/8	*	...	361C	1	7/8	5/8	...
(h) 227A	2	5/8	*	227					

- (*) Vertical center 5/8" when mounted in double horizontal rows with lugs in opposite directions and 1/8" when mounted in double horizontal rows with lugs in the same direction.
- (a) The terminal of the tip springs is arranged to accommodate two No. 16 B & S gauge wires.
- (b) The terminal of the tip spring and the terminal of the spring which makes contact with it are arranged to accommodate two No. 16 B & S gauge wires.
- (c) Same as No. 217A Jack except it has a nickel-silver sleeve.
- (d) Same as the No. 218A Jack except equipped with platinum contacts.
- (e) Same as the No. 221 type except the terminal of the tip spring is arranged to accommodate two No. 16 B & S gauge wires.
- (f) The terminals of all springs are arranged to accommodate two No. 16 B & S gauge wires.
- (g) Same as the No. 225A Jack except equipped with platinum contacts.
- (h) The terminals of the tip and ring springs are arranged to accommodate two No. 16 B & S gauge wires.
- (j) Local contacts not designed for use in talking circuits.
- (k) The same as the No. 232A Jack except equipped with platinum contacts.
- (L) Normally closed contacts are not designed for use in talking circuits.
- (m) Cannot be used with Nos. 137, 152, 154, 209, 217, 218, 220, 241, 246 and 249 Plugs.
- (n) Heavily insulated jacks.
- (o) Same as No. 303A Jack except equipped with platinum contacts.

JACKS

Singly Mounted—Welded Frame—Continued

JACKS FOR USE WITH No. 109 TYPE PLUG

Code No.	Dimensions Page 122 Fig. No.	—Mounting Centers, Inches—		Replaces Jack No.
		Horizontal	Vertical	
246A	3	$\frac{5}{8}$	$\frac{7}{8}$	126
246B	3	$\frac{5}{8}$	$1\frac{1}{8}$...
(a) 246E	3	$\frac{5}{8}$	$\frac{7}{8}$...
248A	3	$\frac{5}{8}$	$\frac{7}{8}$	134
248B	3	$\frac{5}{8}$	$1\frac{1}{8}$...
248D	3	$1\frac{1}{8}$	$\frac{5}{8}$...
(b) 248E	3	$\frac{5}{8}$	$\frac{7}{8}$...
249A	3	$\frac{5}{8}$	$\frac{7}{8}$	143
249B	3	$\frac{5}{8}$	$1\frac{1}{8}$...

(a) Same as the No. 246A Jack except equipped with nickel-silver sleeve.

(b) Same as the No. 248A Jack except equipped with nickel-silver sleeve.

JACKS FOR USE WITH Nos. 110, 150, 184, 202 AND 213 TYPE PLUGS

Code No.	Dimen- sions Page 122 Fig. No.	Mounting Centers, Inches		Re- places Jack No.	Code No.	Dimen- sions Page 122 Fig. No.	Mounting Centers, Inches		Re- places Jack No.
		Horizontal	Vertical				Horizontal	Vertical	
238A	2	$\frac{5}{8}$	$\frac{7}{8}$	159	243B	2	$\frac{3}{4}$	$1\frac{1}{8}$	184
238B	2	$\frac{5}{8}$	$1\frac{1}{8}$	178	245A	2	$\frac{29}{32}$	$\frac{7}{8}$...
238C	2	$\frac{7}{8}$	$\frac{5}{8}$	274	245B	2	$\frac{29}{32}$	$1\frac{1}{8}$...
238D	2	$1\frac{1}{8}$	$\frac{5}{8}$...	245C	2	$\frac{29}{32}$	$\frac{5}{8}$...
(a) 238E	2	$\frac{5}{8}$	$1\frac{1}{8}$...	(d) 267A	2	$1\frac{1}{16}$	$\frac{5}{8}$...
239A	2	$\frac{5}{8}$	$\frac{7}{8}$	160	280A	2	$\frac{7}{8}$	$\frac{7}{8}$...
239B	2	$\frac{5}{8}$	$1\frac{1}{8}$	179	280B	2	$\frac{7}{8}$	$1\frac{1}{8}$...
239C	2	$\frac{7}{8}$	$\frac{5}{8}$	260	280C	2	$\frac{7}{8}$	$\frac{5}{8}$...
239D	2	$1\frac{1}{8}$	$\frac{5}{8}$...	284A	2	1	$\frac{7}{8}$...
(b) 239E	2	$\frac{5}{8}$	$\frac{7}{8}$...	284B	2	1	$1\frac{1}{8}$...
240A	2	$\frac{3}{4}$	$\frac{7}{8}$	161	285A	2	$\frac{13}{16}$	$\frac{7}{8}$...
240B	2	$\frac{3}{4}$	$1\frac{1}{8}$	180	285B	2	$\frac{13}{16}$	$1\frac{1}{8}$...
240C	2	$\frac{7}{8}$	$\frac{5}{8}$...	285C	2	$\frac{7}{8}$	$\frac{5}{8}$...
241A	2	$\frac{3}{4}$	$\frac{7}{8}$	162	289B	4	$\frac{15}{16}$	$1\frac{1}{8}$...
241B	2	$\frac{3}{4}$	$1\frac{1}{8}$	181	290B	4	$\frac{15}{16}$	$1\frac{1}{8}$...
241C	2	$\frac{7}{8}$	$\frac{5}{8}$...	291B	2	1	$1\frac{1}{8}$...
241D	2	$1\frac{1}{8}$	$\frac{5}{8}$...	293B	2	$\frac{15}{16}$	$1\frac{1}{8}$...
242A	2	$\frac{3}{4}$	$\frac{7}{8}$	163	300A	2	$\frac{5}{8}$	$\frac{7}{8}$	282
242B	2	$\frac{3}{4}$	$1\frac{1}{8}$	182	360A	2	$\frac{23}{32}$	$\frac{7}{8}$...
242C	2	$\frac{7}{8}$	$\frac{5}{8}$	259	387B	2	$\frac{13}{16}$	$1\frac{1}{8}$...
(c) 242CK	2	$\frac{7}{8}$	$\frac{5}{8}$...	387D	2	$1\frac{1}{8}$	$\frac{5}{8}$...
243A	2	$\frac{3}{4}$	$\frac{7}{8}$	165					

(a) Same as the No. 238B except equipped with a nickel-silver sleeve.

(b) Same as the No. 239A except equipped with a nickel-silver sleeve.

(c) Equipped with platinum contacts.

(d) Heavily insulated jack.

JACKS (Continued)

Singly Mounted—Miscellaneous Types

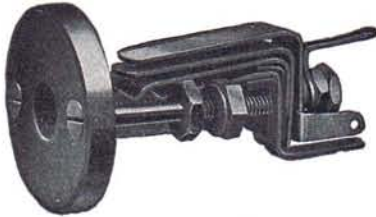

No. 77 Jack



No. 389A-3 Jack

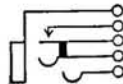

No. 77

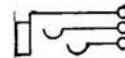

No. 78

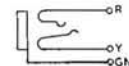

No. 389A-3

Code No.

Description

- 77 Operator's telephone set. Makes one separate contact when a No. 148 Plug is inserted; has tip, ring and sleeve terminals.
- 78 Same as No. 77 Jack, except that the make contact is omitted. Diameter of mounting plate $1\frac{1}{16}$ inches.
- 389A-3 This jack is intended for use in locations where it is desirable to move a telephone from place to place. The No. 273A-3 Plug is used with this jack; it is provided with tip, ring and sleeve connections. The cover is $1\frac{1}{16}$ inches square and 1 inch deep, and is finished black. The base and cover are slotted to allow wires to be brought in from wire moulding.



No. 200 Jack

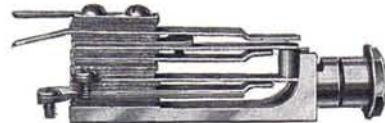

No. 224 Jack

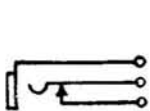

No. 200

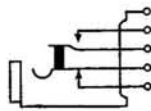

No. 203

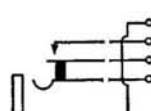

No. 208



No. 224

The Nos. 200, 203, 208 and 224 are fibre insulated jacks having micanite bushings. They will mount on any thickness of wood from $\frac{3}{4}$ to $\frac{7}{8}$ inch, the jack shank being threaded and the jack held in place by means of a nickel finished nut.

Code No.	Mounting Centers, Inches		Used with Plugs	Used in Jack Boxes
	Horizontal	Vertical		
200	$1\frac{5}{16}$	1	1A, 47 & 116
203	$1\frac{5}{16}$	$1\frac{1}{4}$	1A, 47 & 116
208	$1\frac{5}{16}$	$1\frac{1}{8}$	1A, 47 & 116	385, 386 & 389
224	$1\frac{5}{16}$	$1\frac{1}{2}$	1A, 47 & 116	385, 386 & 389

JACKS

Singly Mounted—Miscellaneous Type—Continued

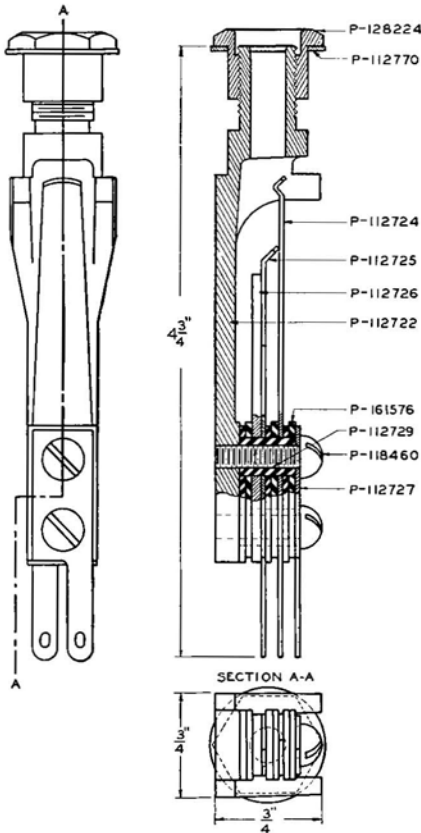

No. 200 Jack

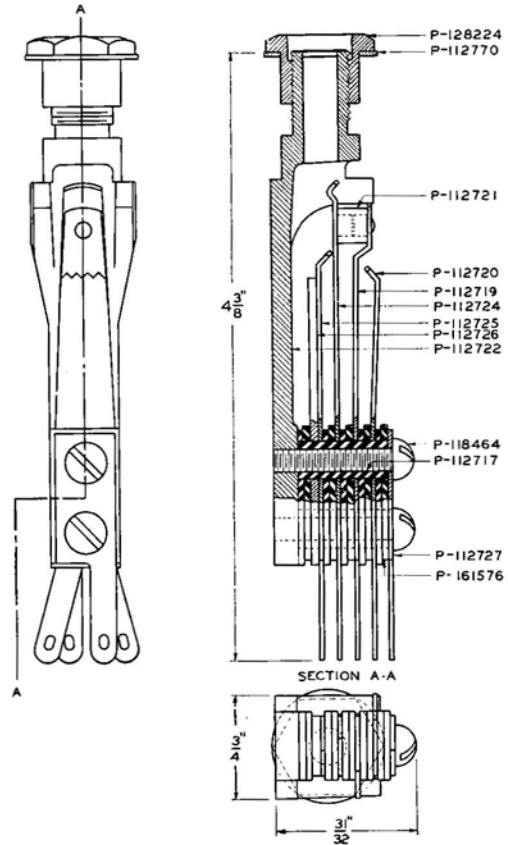

No. 203 Jack

Replacement Parts

No. 200 Jack			
Piece Part No.	No. Req.	Material	Name
P128224	1	Brass	Sleeve Nut
P112770	1	Brass	Washer
P112724	1	Ger. Silver	Tip Spring
P112725	1	Ger. Silver	Contact Spring
P112726	1	Brass	Stop Spring
P112722	1	Brass	Frame
P161576	6 & As Req.	Phenol Fibre	Insulator
P112729	2	Micanite	Bushing
P118460	2	Brass	R.H.M. Screw
P112727	1	Ger. Silver	Terminal

No. 203 Jack			
Piece Part No.	No. Req.	Material	Name
P128224	1	Brass	Sleeve Nut
P112770	1	Brass	Washer
P112721	1	Micanite	Bushing
P112720	1	Ger. Silver	Contact Spring
P112719	1		Contact Spring & Stud
P112724	1	Ger. Silver	Tip Spring
P112725	1	Ger. Silver	Contact Spring
P112726	1	Brass	Stop Spring
P112722	1	Brass	Frame
P118464	2	Brass	R.H.M. Screw
P112717	2	Micanite	Bushing
P112727	1	Ger. Silver	Terminal
P161576	10 & As Req.	Phenol Fibre	Insulator

JACKS

Singly Mounted—Miscellaneous Type—Continued

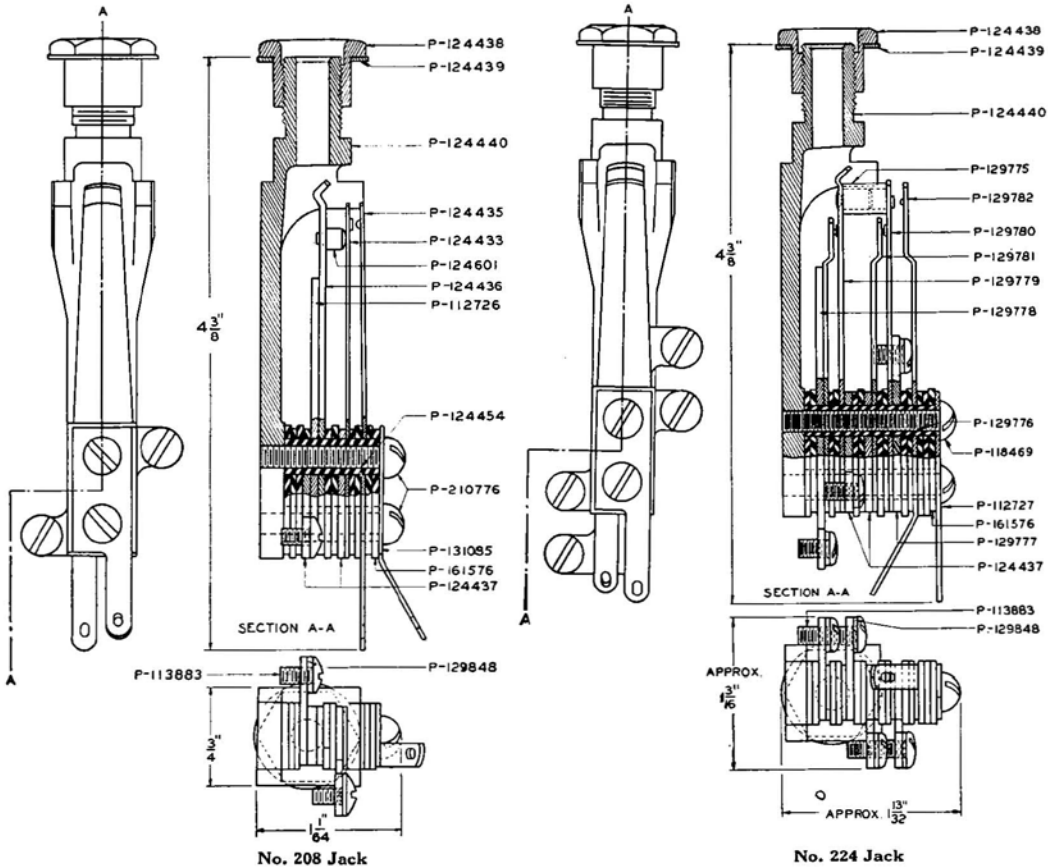

Replacement Parts

No. 208 Jack				No. 224 Jack			
Piece Part No.	No. Req.	Material	Name	Piece Part No.	No. Req.	Material	Name
P124438	1	Brass	Sleeve Nut	P124438	1	Brass	Sleeve Nut
P124439	1	Brass	Washer	P124439	1	Brass	Washer
P124440	1	Brass	Frame	P124440	1	Brass	Frame
P124435	1		Contact Spring	P129775	1	Micanite	Bushing (Separator)
P124433	1		Contact Spring	P129782	1		Contact Spring
P124601	1	Hd. Rubber	Separator	P129780	1		Contact Spring
P124436	1	Nickel Silver	Tip Spring	P129781	2		Contact Spring
P112726	1	Brass	Stop Spring	P129779	1		Tip Spring
P124454	2	Micanite	Bushing	P129778	1	Brass	Terminal
P210776	2	Steel	R.H.M. Screw	P129776	2	Micanite	Bushing
P131035	1	Nickel Silver	Terminal	P118469	2	Brass	R.H.M. Screw
P161576	9 & As Req.	Phenol Fibre	Insulator	P112727	1	Ger. Silver	Terminal
P124437	2	Brass	Terminal	P161576	13	Phenol Fibre	Insulator
P129848	2	Brass	Washer	P129777	1	Brass	Terminal
P113883	2	Brass	Button H.M. Screw	P124437	2	Brass	Terminal
				P113883	4	Brass	Button H.M. Screw
				P129848	4	Brass	Washer

JACKS—Continued

For Mounting in Strips



No. 110 Jack Mounting with No. 141 Jack

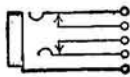

No. 50

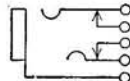

No. 141



No. 229



No. 295



No. 92

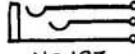

No. 193



No. 275

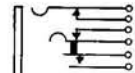

No. 308

These jacks are designed for mounting in groups in jack mountings, a few of which are listed under "Jack Mountings." In ordering, the code number of the jack and the code number of the jack mountings should be given as well as the total number of jacks and mountings required.

The number of jacks to be mounted per strip should be specified and the numbering desired, as they will otherwise be furnished unnumbered.

These jacks are not supplied unmounted.

Code No.	Used with Plug No.	Used with Jack Mounting	No. per Strip
49	110	1-2-34-77	5, 10 and 20
50	110	1-2-34-77	5 and 10
92	109	18-19-113	10 and 20
141	110	109-110-112	10 and 20
193*	110	{ 117-118-119 120-122-123 125-127 }	10 and 20
229	109	145	10
275	110	{ 109-110-112 115-116-136 137 }	10 and 20
295	110	{ 107-108-109-110 112-115-116-131 136 or 137 }	10 and 20
308	110	{ 109-110-116-131 136-137 }	10 and 20

* The No. 119 Tool is designed for extracting and replacing the sleeve of the No. 193 Jack.

JACK BOXES**No. 60A JACK BOX**

The No. 60A Jack Box, as shown above, equipped with ten No. 60A or No. 60D Combined Jack and Signals is for use at way stations where it is desired to connect a single telephone set to one of several telephone lines. Incoming calls are indicated visually by means of drop signals and also, if desired, announced audibly by a buzzer.

The operator's telephone set is put into circuit by inserting a plug into the jack indicated by the fallen shutter. The signal is restored automatically to its original position by this operation.

In addition to the combined jack and signals, the jack box contains a ringing key, buzzer, terminal plate, and a solid plug attached to the box by a cord.

The cabinet is made of brass finished in black and is 10" long, 7½" high, and 7½" deep.

The No. 60A Combined Jack and Signals have a low resistance of 82 ohms for use on train lines and the signals should be connected in multiple with the ringer in the selector set as shown for Signal 5 of the schematic. Whenever the selector is operated to its local ringing position, the No. 60CG Ringer in the selector set and the associated signal in the jack box will both be operated.

The No. 60D Combined Jack and Signals have a resistance of 1000 ohms and should be connected directly to a local or block line as shown for Signal 1 in the schematic. In this case the signal will be operated directly by a hand generator or a ringing interrupter over the line wires and the buzzer in the local circuit of the signal contact will follow the code ringing.

The winding of each signal is brought out to two separate terminals on the terminal plate in the top of the box so that the signals may be connected to the local circuit of the selector sets on train and message lines that are part of the phantom circuit. The connections from the train and message wires to the jack springs are open when the plug is not in the jack and thus cause no interference on the phantom circuits.

The ringing key has three positions. The normal position is for incoming calls and the talking position. When the key handle is operated down to the "R" position, the outgoing ringing circuit is completed through the jack springs of the jack in which the plug is inserted to the corresponding line. Also the circuit to the operator's telephone set is opened. When the key handle is operated to the "C" position, the code ringing circuit to the buzzer is opened. The key is locking in the "C" position and non-locking in the "R" position.

Provision is made in the wiring so that on lines, where ringing is not desired, this may be accomplished by disconnecting the black wires from the bottom terminal in the jack spring pileup associated with that line.

When less than full capacity of ten combined jacks and signals is required, the unequipped positions are fitted with No. 70A Apparatus Blanks. However, in all cases, the jack box is furnished completely wired for ten combined jacks and signals.

**No. 345A Jack Box****No. 385A Jack Box**

JACK BOXES (Continued)

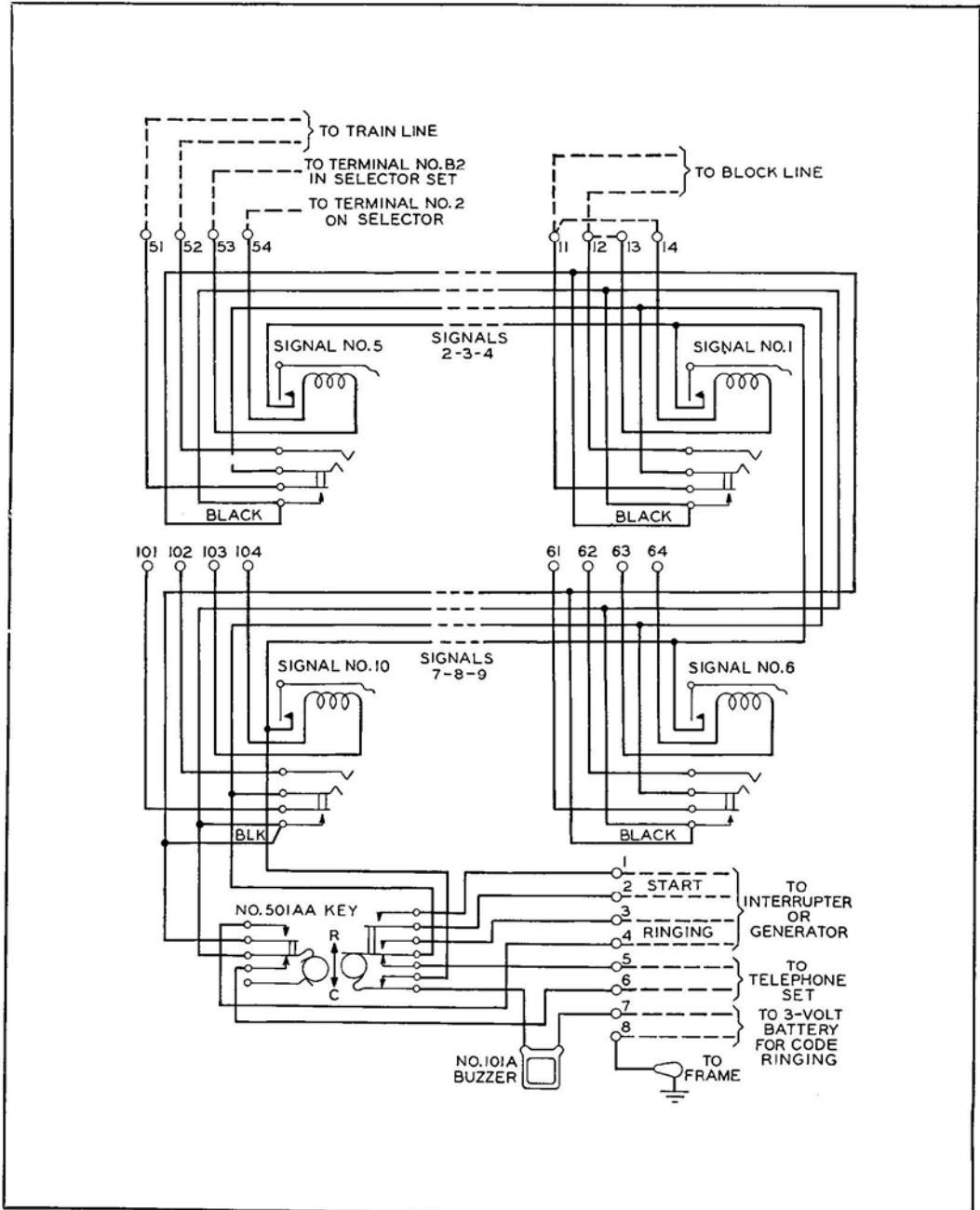

Schematic of No. 60A Jack Box

JACK BOXES—Continued

NO. 345A JACK BOX

Oak box primarily for use in train dispatching circuits at dispatcher's office and is so arranged that two headsets can be connected to the line at the same time.

Equipped with one No. 30 Jack Mounting, two No. 237C Jacks and two No. 221C Jacks.

Approximate dimensions, length 5½", width 4¾", height 2".

Jack Boxes—Cordless

Oak boxes with nickel trimming for miscellaneous purposes. Each box is equipped with hinge cover and a No. 1A Plug attached by means of a dummy cord. The No. 389 Type is split and hinged on a line midway between the upper and lower jack levels.

Telephone Jack Boxes Nos. 385A, B, 386A, B, C, and 389A are so arranged that one telephone line can be terminated in each jack. A telephone set can be connected to any of these lines by inserting the plug in the proper jack.

Telegraph Jack Boxes Nos. 385C, D, 386D, E, F, and 389B are so arranged that one telegraph line can be looped through each jack. Resonator set can be connected to any of these lines by inserting the plug in the proper jack. When this is done, the calling set is disconnected.

Code No.	Line Equipment	Capacity	Equipped with Jacks	Service	Dimensions, Inches		
					Width	Height	Depth
*385A	2	3	208	Telephone	4½	2¾	6¼
385B	3	3	208	Telephone	4½	2¾	6¼
*385C	2	3	224	Telegraph	4½	2¾	6¼
385D	3	3	224	Telegraph	4½	2¾	6¼
*386A	4	6	208	Telephone	7½	2¾	6¼
*386B	5	6	208	Telephone	7½	2¾	6¼
386C	6	6	208	Telephone	7½	2¾	6¼
*386D	4	6	224	Telegraph	7½	2¾	6¼
386E	5	6	224	Telegraph	7½	2¾	6¼
386F	6	6	224	Telegraph	7½	2¾	6¼
389A	12	12	208	Telephone	7½	4¾	6¼
389B	12	12	224	Telegraph	7½	4¾	6¼

* No. 17C Apparatus Blank, illustrated in the center jack position on the cut of the No. 385A Jack Box, is furnished in all unequipped positions.

Jack Fasteners

These Fasteners serve the purpose of holding either jack mountings or lamp socket mountings in place on the switchboard frame. They are made of brass.

The No. 103 Tool listed under "Tools" should be used in placing and removing Fasteners.



No. 16



No. 19

Code No.	Used On
15	No. 49 Jack Sections, Nos. 9C and 109A Switchboards having slotted stile strips.
16	No. 92 Jack Sections having drilled stile strips.
19	Nos. 49 and 193 Jack Sections having drilled stile strips on 1 inch centers.
21	No. 49 Jack Sections having stile strips drilled on ¾ inch centers.
25	No. 5 Toll Test Board to clamp Nos. 184 and 185 Jack Mountings and No. 262 Lamp Socket Mountings on relay racks.

JACK MOUNTINGS

For central battery exchanges it is customary to have the multiple jack strips in each panel separated into groups of five rows by thin white holly strips. Each group consists of one hundred jacks numbered 0 to 99. Each strip has 20 jacks and is divided into four smaller groups (each having five jacks) by a distinctive mark so that an operator may readily choose the proper jack. It is also usual to furnish these Jack Mountings with a groove on the lower edge for marking the jacks for various purposes such as signifying that several adjoining jacks are connected to one private exchange, etc.

In ordering, specify the number of jacks and the Code No., the Code No. of the Jack Mounting with the number per strip, together with the numbering desired. If the holly strips are to be attached to the upper edge of any of the Jack Mountings, the order should specify which ones.

The No. 80 Jack Mounting is so designed that the twin plug of an operator's head set may be inserted in each pair of jacks. Mountings will be furnished unnumbered unless otherwise specified.

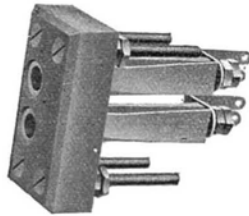

No. 80 with No. 99 Jacks

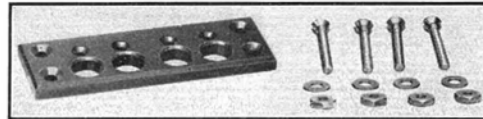

No. 199A Jack Mounting

Code No.	Used with Mounting Jack No.	Ordinarily Used with Plug No.	No. of Jacks per Strip	Mounting Face, Dimensions, Ins.	
				Length	Width
80	99 or 234	137	2	2 3/8	1 1/4
114	49	110	20	9 5/16	7/16
128	219C or similar Jack	47	10	6 21/32	1 1/4
129		47	20	6 21/32	2 1/8
130	236C	47	10	6 21/32	1 1/4
135		47	30	21 3/4	1 3/8
143	238A	110	10	9 3/16	1
184	218 or similar type	47	24	16 15/16	1 1/4
185			48	16 13/16	2 1/8
189A	240A	110	10	11 3/16	1 5/8
199A	364 or 396	47 or 137	4	3 3/4	1 1/4

NO. 148 JACK MOUNTING

This ebony finished wood box is primarily designed for mounting a No. 218A or similar type jack on the side of a desk. Two wood screws with washers are provided for fastening it in place. The overall dimensions are length 5 inches, width 2 5/16 inches and depth 1 21/32 inches.

JACK SPACES



No. 63A Jack Space



No. 101A Jack Space

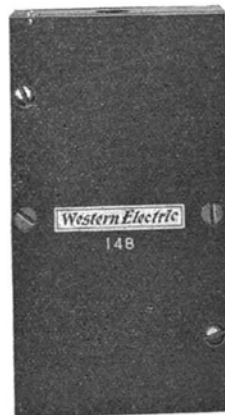

No. 148 Jack Mounting

Code No.	Width of Face, Ins.	Finish	Remarks
1M	2 7/32	Mahogany	Equipped with 1/16" Holly Strip (included in dimension given).
1AK	3/16	Insulator for use between No. 114 Jack Mounting and No. 102 Lamp Socket Mounting when equipped with No. 30 Lamp Sockets.
62A	1/8	Dull Black Fibre	Intended for use with No. 184 or No. 185 Jack Mountings and No. 262 Lamp Socket Mountings on relay rack.
62B	1/4	" " "	
62C	3/8	" " "	Recommended in place of two No. 101A wherever practicable.
63A	1/2	" " "	
63B	5/8	" " "	Recommended in place of two No. 112C.
63C	1 1/4	" " "	
63D	2 1/8	" " "	Intended to mount in place of Nos. 133, 134 and 135 Jack Mountings in Nos. 105A and B Switchboards.
101A	1 1/16	" " "	
101AB	7/8	" " "	
112AG	3/4	" " "	
127A	11/16	" " "	
127C	1/4	" " "	
127F	7/16	" " "	
127N	1 1/4	" " "	
159A	1/16	" " "	
164A	5/8	" " "	

KEYS



Singly Mounted Type

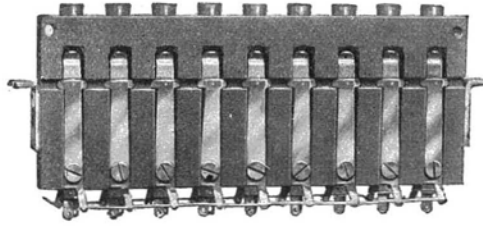

Group Mounted Type

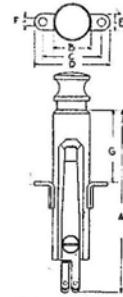

Dimensional Drawing

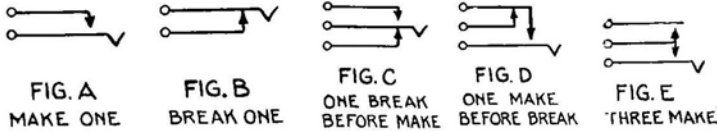

The above contact spring arrangements represent the normal or unoperated contact spring positions of the keys listed below.

Singly Mounted Type Keys

LOCKING TYPE

(Button locks up when depressed to operated position)

Code No.	No. of Springs	Spring Arrangement	Dimensions, Inches (See Dimension Cut)								
			A	B	C	D	E	F	*G		
92B	6	2 sets Fig. C	3 ³ / ₃₂	2 ¹ / ₃₂	1 ¹ / ₃₂	1 ⁵ / ₁₆	3 ¹ / ₃₂	5 ¹ / ₃₂	1 ¹ / ₁₆	7 ¹ / ₈	1 ¹ / ₄
92D	9	3 sets Fig. C									
92H	8	1 set Fig. A—2 sets Fig. C									
92N	3	1 set Fig. C									
92P	2	1 set Fig. A									
424B	6	3 sets Fig. A	3 ⁷ / ₃₂	2 ¹ / ₃₂	1 ¹ / ₃₂	1 ⁵ / ₁₆	3 ¹ / ₃₂	5 ¹ / ₃₂	1 ¹ / ₁₆	7 ¹ / ₈	1 ¹ / ₄

NON-LOCKING TYPE

(Regular Push Button Operation)

Code No.	No. of Springs	Spring Arrangement	Dimensions, Inches (See Dimension Cut)								
			A	B	C	D	E	F	*G		
92A	6	2 sets Fig. C	3 ³ / ₃₂	2 ¹ / ₃₂	1 ¹ / ₃₂	1 ⁵ / ₁₆	3 ¹ / ₃₂	5 ¹ / ₃₂	1 ¹ / ₁₆	7 ¹ / ₈	1 ¹ / ₄
92J	6	1 set Fig. A									
92W	6	2 sets Fig. B									
92Y	4	2 sets Fig. D									
188A	4	2 sets Fig. A									
188D	6	2 sets Fig. A	3 ⁷ / ₃₂	9 ¹ / ₁₆	1 ⁵ / ₁₆	1 ⁷ / ₃₂	3 ¹ / ₃₂	5 ¹ / ₃₂	1 ¹ / ₁₆	7 ¹ / ₈	1 ¹ / ₄
188E	4	2 sets Fig. C	3 ⁷ / ₃₂	9 ¹ / ₁₆	1 ⁵ / ₁₆	1 ⁷ / ₃₂	3 ¹ / ₃₂	5 ¹ / ₃₂	1 ¹ / ₁₆	7 ¹ / ₈	1 ¹ / ₄
424A	6	3 sets Fig. A	3 ⁷ / ₃₂	2 ¹ / ₃₂	1 ¹ / ₃₂	1 ⁵ / ₁₆	3 ¹ / ₃₂	5 ¹ / ₃₂	1 ¹ / ₁₆	7 ¹ / ₈	1 ¹ / ₄
464A	2	1 set Fig. B	3 ³ / ₃₂	1 ¹ / ₂	7 ¹ / ₈	1 ⁵ / ₃₂	3 ¹ / ₃₂	5 ¹ / ₃₂	9 ¹ / ₆₄	1 ⁵ / ₁₆	1 ¹ / ₄
464B	2	1 set Fig. A									

Group Mounted Type Keys

These are group mounted type, push-button, order wire keys for use with various key mountings. The keys are equipped with colored plunger buttons as noted. Key mountings are listed elsewhere.

LOCKING TYPE

Code No.	Color	No. of Springs	Spring Arrangement	Key Mounting Code Numbers
248A	Black	2	1 set Fig. C	211, 212, 232, 260, 299 & 320

NON-LOCKING TYPE

69A	Red	4	2 sets Fig. A	233, 235, 303, 304, 312, 315, 323, 324, 341
492A	Red or Black	2	1 set Fig. A	342, 343, 344 and 346

* Arranged for thickness of shelf as indicated.

KEYS—Continued

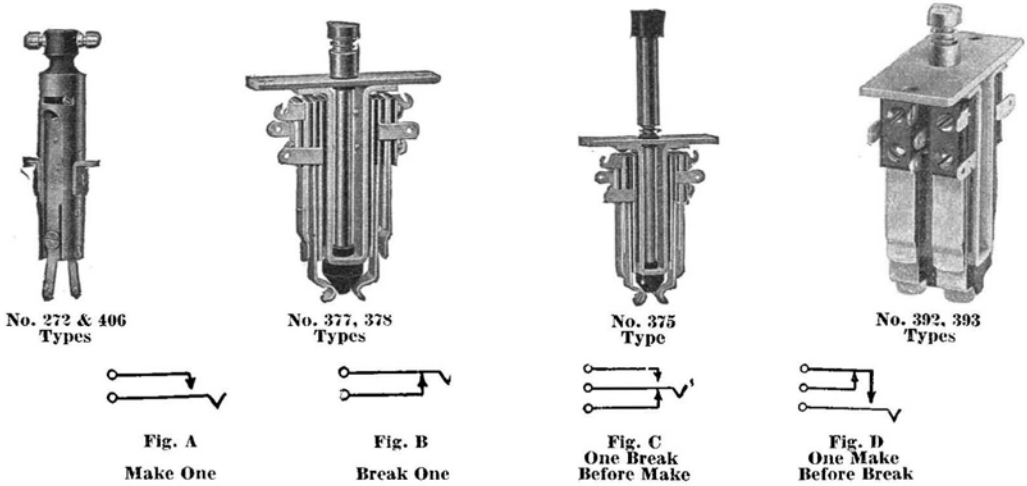

The above contact spring arrangements represent the normal or unoperated spring positions of the keys listed below.

Keys Equipped with Rotating Cams

Singly mounted metal shell keys having hard rubber rotating cam which when operated, breaks and makes contacts and locks in its operated position, otherwise having same construction as No. 92 Type Keys.

Code No.	No. of Springs	Contact Spring Arrangement	Key Shelf Mounting
272A	6	2 sets Fig. C	1/16, 7/8 or 1 1/4 inch as spec.
272C	9	3 sets Fig. C	
272D	12	4 sets Fig. C	
272F	6	2 sets Fig. C	
272G	3	1 set Fig. C	1/16, 7/8 or 1 1/4 inch as spec.
406A	2	1 set Fig. B	
406C	4	2 sets Fig. A	3/8, 1/16, 7/8 or 1 1/4 inch as spec.
406J	6	2 sets Fig. D	
406P	4	1 set Fig. B—1 set Fig. A	

Rotating Button Type Keys

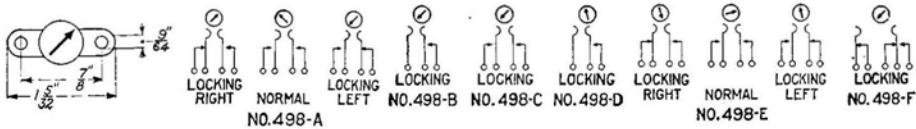

Single mounted rotating type keys. Buttons of Nos. 498A, 498E and 498H are arranged to rotate 180 degrees. The others are arranged to rotate 90 degrees to the right only. Each button is engraved with an arrow to indicate its rotated position. The color of each button is red with the exception of the No. 498F Button which is black. Otherwise having same construction as above No. 272 Type Keys.

Code Nos. 498A, 498B, 498C, 498D, 498E, 498F.

Plunger Type Keys

FOR USE WITH KEY LEVERS

The following plunger type keys each have but one plunger rod for its operation. The No. 375A Key is a push button type. All other keys listed below are locking or non-locking in operation according to the type of key lever used. (Key levers are listed elsewhere.)

Code No.	No. of Springs	Spring Arrangement	Code No.	No. of Springs	Spring Arrangement
375A	6	2 sets Fig. C	392F	24	8 sets Fig. C
377A	4	2 sets Fig. A	393A	9	3 sets Fig. C
378A	6	2 sets Fig. C	393D	10	4 sets Fig. B—1 set Fig. A
392A	12	4 sets Fig. C	490A	2	1 set Fig. C
392D	14	4 sets Fig. C—1 set Fig. B	511A	20	10 sets Fig. A
			511B	30	10 sets Fig. C

KEYS—Continued

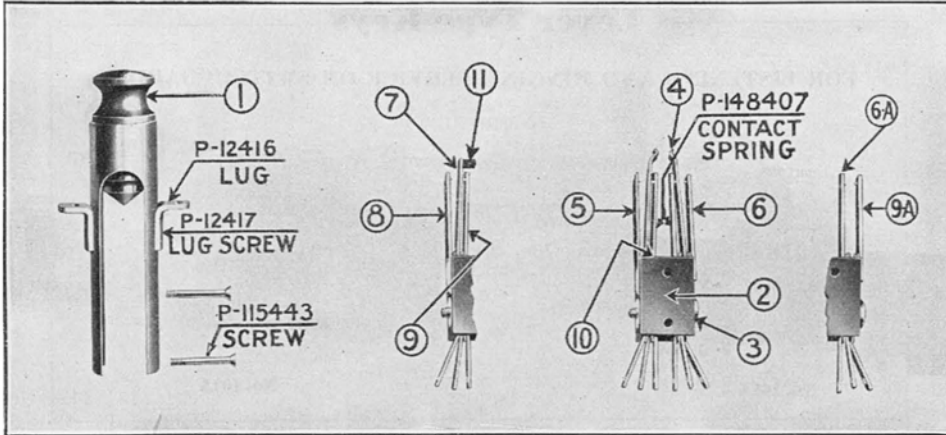

**Replacement Parts for Push Button and Rotary Lever Keys
Nos. 92, 188, 272, 406, 424 and 464 Types**

Key No.	(1) Plunger or Cam		(2) Spring Mounting Block	(3) Mounting Block Screw	(4) Plunger Springs	(5) (6) & (8A) Contact Springs with Mounting Block Screw Head (3) at Right	
	Black	Red				(5)	(6) & (8A)
92A	P-143908	P-166912	P-163582	P- 19297	P-148403	P-148698	P-149565
92B	P-143909	P-166906	P-163582	P- 19297	P-148403	P-148698	P-149565
92D	P-143909	P-166906	P-163585	P-111381	P-148403	P-148675	P-149565
92J	P-143908	P-166912	P-163582	P- 19297	P-149572	P-148535
92R	P-143908	P-166912	P-163589	P-147982	P- 39347	P-142468
92T	P-143908	P-166912	P-163582	P-113884	P-149572	P-149565
92Y	P-143908	P-166912	P-163582	P- 19297	P-148253	P-148698	P-149565
188D	P- 42188	P-166918	P-163595	P- 19297	P-149332	P-149335	P-148698
188E	P-163928	P-166922	P-163595	P- 16583	P-147930	P-147931	P-147932
272A	*P-131698	*P-167372	P-163582	P-113884	P-147881	P-148338	P-148372
272C	*P-131698	P-167372	P-163585	P-111381	P-147881	P-148675	P-148372
272D	*P-131698	*P-167372	P-163585	P-111944	P-147881	P-148675
272F	*P-131699	*P-166926	P-163584	P-129761	P-147881	P-148338	P-148338
272G	*P-131698	*P-167372	P-163582	P- 19297	P-147881	P-148338
406A	*P-131698	*P-167372	P-163582	P- 16583	P-148536	P-147887
406C	*P-131699	*P-166926	P-163582	*P-113884	P-149170	P-148338	P-148372
421A	P-143908	P-166912	P-163589	P- 29620	P-148235	P-148673	P-149565
421B	P-143909	P-166906	P-163589	P- 29620	P-148235	P-149566	P-149565
421C	P-143909	P-166906	P-163589	P-111381	P-148235	P-148656	P-147902
421D	P-143908	P-166912	P-163589	P-107721	P-148235	P-149416	P-149416
461A	P-100050	P-165497	P-163595	P-100172	P-149198	P-148485
461B	P-100050	P-165497	P-163595	P-121480	P-148336	P-100009

Key No.	(7) (8) (9) and (9A) Contact Springs (With Mounting Block Screw Head (3) at Right)		(10) Hard Rubber Insulators		(11) Separator
	(7)	(8)	Large	Small	
92A	P-109716	P-109717
92B	P-109716	P-109717
92D	P-148699	P-148535	P-162422	P-162420	P-113755
92J	P-163471	P-162422	P-162420	P- 23975
92R	P-142469	P-162430	P-162422	P-162420	P-142472
92T	P-163471	P-148535	P-162422	P-162420	P- 23975
92Y	P-109716	P-109717
188D	P-109716	P-109717
188E	P-109716	P-109717
272A	P-109716	P-109717
272C	P-147893	P-148698	P-162422	P-162420	P-107684
272D	P-147894	P-148698	P-162422	P-162420	P-107684
272F	P-129760	P-129759
272G	P-109716	P-109717
406A	P-109716	P-109717
406C	P-109716	P-109717
421A	P-148693	P-148537	P-162422	P-162420	P- 34308
421B	P-148693	P-148537	P-162422	P-162420	P- 34308
421C	P-148693	P-148537	P-162422	P-162420	P- 34308
421D	P-149120	P-149513	P-162422	P-162420	P- 34308
461A	P-109716	P-109717
461B	P-109716	P-109717

* Note. The following parts are not included with the above cams, but must be ordered separately:
 Cam Stud P-131696 Cam Stud Nut P-131697 Stop Pin P-32819

KEYS—Continued

Lever Type Keys

FOR LISTENING AND RINGING SERVICE ON SWITCHBOARDS

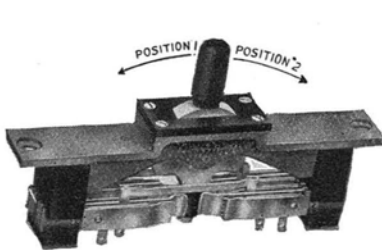

No. 104A

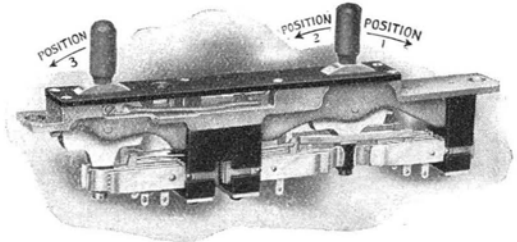

No. 102A

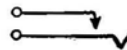

Fig. A
Make One

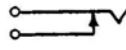

Fig. B
Break One

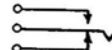

Fig. C
One Break
Before Make

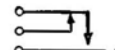

Fig. D
One Make
Before Break

The above contact spring arrangements represent the normal or unoperated contact spring positions.

Single Lever Type

Size of top 1½ x ¾ inches

Code No.	No. of Contacts	Contact Spring Arrangement		Corresponding Key Space Code No.
		Position 1	Position 2	
LOCKING IN BOTH POSITIONS				
136A, *136B	12	2 sets Fig. C	2 sets Fig. C	104B
155A	12	2 sets Fig. C	104B
COMBINED LOCKING AND NON-LOCKING				
*104A	10	2 sets Fig. C	2 sets Fig. A	104B
184B	12	2 sets Fig. C	2 sets Fig. C	104B
*264A	14	2 sets Fig. C	2 sets Fig. C and 1 set Fig. A	104E

Double Lever Type

Size of top 5¼ x ¾ inches

Code No.	No. of Contacts	Contact Spring Arrangement			Corresponding Key Space Code No.
		Position 1 Non-Locking	Position 2 Locking	Position 3 Non-Locking	
†*102A	16	2 sets Fig. C	2 sets Fig. A	2 sets Fig. C	102B
†*110A	18	2 sets Fig. C	3 sets Fig. A	2 sets Fig. C	102B
156A	18	2 sets Fig. C	3 sets Fig. A	2 sets Fig. C	102B
256B	18	2 sets Fig. C	2 sets Fig. A and 1 set Fig. B	2 sets Fig. C	102B

Note. * These keys have common strap wire connections between main springs.
 † These keys equipped with indicators to show which ringing lever was last operated.

KEYS AND PARTS FOR SINGLE AND DOUBLE LEVER TYPE KEYS

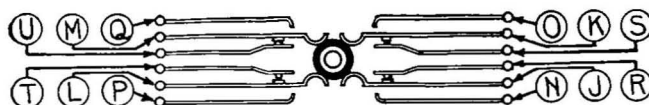
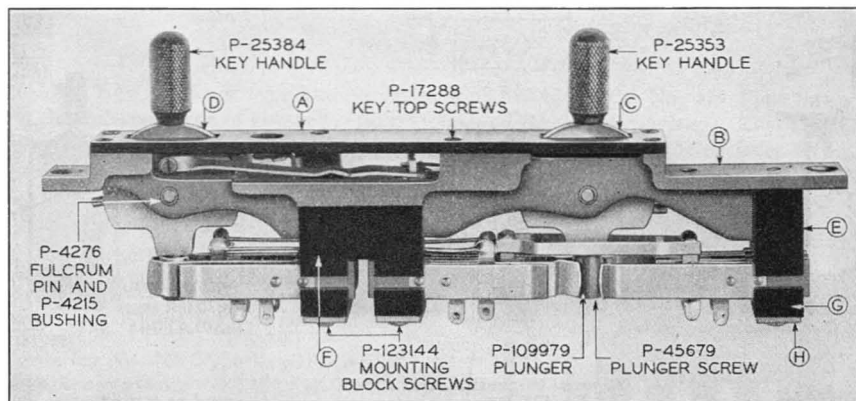

Symbol Key No.	A Key Top Plate	B Key Base	C Lever Assembly	D Lever Assembly	E Spring Mounting Block	F Spring Mounting Block	G Spring Clamp Block	H Spring Clamp Plate	I Spring Separator
102A, B, C	P-163323	P-122755	P- 25363	P- 25360	P- 4252	P- 4305	P- 4254	P-112188
103A	P-163323	P-122756	P- 25360	P- 25360	P- 4305	P-112188
104A	P-112730	P-122757	P- 25355	P- 4252	P- 4252	P- 4254	P-112188	P- 4264
110A	P-163323	P-122755	P- 25363	P- 25360	P- 33686	P- 4305	P- 33688	P-112188
110D	P-163324	P-122755	P- 25363	P- 25360	P- 33547	P- 4305	P- 33548	P- 5802
115A	P-122730	P-122757	P- 25354	P- 4252	P-112188	P- 4264
118A, B	P-122734	P-122762	P- 25354	P- 16739	P- 4254	P-112188
121A	P-122737	P-122762	P- 25356	P- 4252	P- 4254	P-112188
123A	P-122737	P-122762	P- 25354	P- 16739	P-112188
131A	P-122737	P-122762	P- 25355	P- 4252	P- 16739	P- 4254	P-112188
135A, B	P-122730	P-122757	P- 25362	P- 4252	P- 4252	P- 4254	P-112188	P- 4264
136A	P-122730	P-122757	P- 23358	P- 4252	P- 4252	P- 4254	P-112188	P- 4264
150A	P-122731	P-122761	P- 25358	P- 33547	P- 4252	P- 33548	P- 5802
155A	P-122730	P-122757	P- 25356	P- 4252	P-112188
156A	P-122733	P-122762	P- 25355	P- 25354	P- 33686	P- 4305	P- 33688	P-112188	P- 33495
161A	P-122737	P-122762	P- 25355	P- 33686	P- 16739	P- 33688	P-112188
165A	P-122733	P-122762	P- 25354	P- 25354	P- 4305	P-112188
177A	P-122730	P-122757	P- 25355	P- 33686	P- 4252	P- 33688	P-112188	P- 4264 P-103845
178A	P-122731	P-122761	P- 25355	P- 33547	P- 4252	P- 33548	P- 5802	P- 4264
184A, B	P-122730	P-122757	P- 25355	P- 4252	P- 4252	P- 4254	P-112188	P- 4264
196A	P-122731	P-122761	P- 25358	P- 33547	P- 4252	P- 33548	P- 5802
198A	P-122730	P-122757	P- 25358	P- 33686	P- 4252	P- 33688	P-112188
247A	P-122730	P-122757	P- 25358	P- 33686	P- 4252	P- 33548	P-112188
249A	P-122730	P-122757	P- 25358	P- 33686	P- 4252	P- 33688	P-112188	P- 33495
256B	P-122733	P-122762	P- 25355	P- 25354	P- 33686	P- 4305	P- 33688	P-112188
264A	P-122731	P-122761	P- 25355	P- 33547	P- 4252	P- 33548	P- 5802
369A	P-122730	P-122757	P- 25358	P- 33686	P- 4252	P- 33688	P-112188	P- 4264
415A	P-122731	P-122766	P- 25358	P-129820	P-129820	P-129821	P- 8216

CONTACT SPRING PARTS

Symbol Key	Plunger Springs				Main Contact Springs							
	J	K	L	M	N	O	P	Q	R	S	T	U
104A	P-148505	P-148505	P-148508	P-148686	P-129033	P-129034	P- 17132	P- 17131	P-129032	P-129031
115A	P-148508	P-148686	P- 17132	P- 17131	P-129031	P-129032
135A, B	P-148507	P-148507	P-148508	P-148686	P- 17131	P- 17132	P- 17132	P- 17131	P-129032	P-129031	P-129032	P-129031
136A	P-131275	P-131276	P-131275	P-131276	P-129033	P-129034	P-129033	P-129033	P-131273	P-131274	P-131274	P-131273
150A	P-131275	P-131276	P-131275	P-131276	P-129033	P-129034	P-129034	P-129033	P-148444	P-148445	P-131274	P-131273
155A	P-131275	P-131276	P-129033	P-129034	P-131273	P-131274
156A	P-148123	P-148122	P-148508	P-148686	P-129033	P-129034	P- 17132	P- 17131	P-148365	P-148366	P-129031	P-129032
177A	P-147931	P-148505	P-148508	P-148686	P-129033	P-129034	P- 17132	P- 17131	P-148365	P-148366	P-129032	P-129031
178A	P-148123	P-148122	P-148508	P-148686	P-148367	P-148436	P- 17132	P- 17131	P-148365	P-148366	P-129031	P-129032
181A, B	P-148506	P-148506	P-148508	P-148686	P-129033	P-129034	P- 17132	P- 17131	P-131273	P-131274	P-129032	P-129031
196A	P-147937	P-147938	P-147937	P-147938	P-129033	P-129034	P-129034	P-129033	P-148361	P-148360	P- 33494	P-148361
198A	P-148122	P-148433	P-131275	P-131276	P-129033	P-129034	P-129034	P-129033	P-148365	P-148366	P-131274	P-131273
247A	P-148422	P-148513	P-131275	P-131276	P-129033	P-129034	P-129034	P-129033	P-148365	P-148366	P-131274	P-131273
249A	P-148122	P-148123	P-148122	P-148123	P- 17133	P-129034	P-129034	P-129033	P-148365	P-148366	P-148366	P-148365
264A	P-148506	P-148506	P-148508	P-148686	P-129034	P-129033	P- 17132	P- 17131	P-148444	P-148443	P-153484	P-153483
369A	P-148422	P-148513	P-148122	P-148513	P-129033	P-129034	P-129034	P-129033	P-148365	P-148366	P-148366	P-148365
415A	P-148511	P-148512	P-148512	P-148511	P-148368	P-148371	P-148371	P-148368	P-148494	P-148493	P-1312.4	P-131273

KEYS

Lever Type—Continued

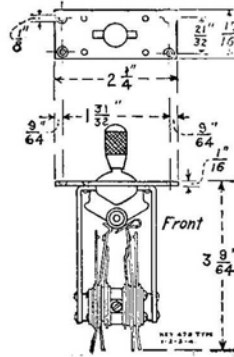
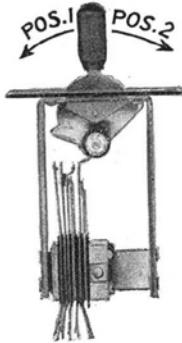

General Dimensions of No. 479 Type

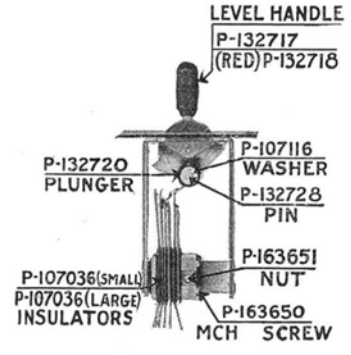

Replacement Parts

Keys have black finished metal tops. Four No. 4 Oval Head Wood Screws are furnished with each key for mounting.

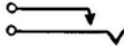

Fig. A
Make One

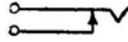

Fig. B
Break One

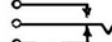

Fig. C
One Break
Before Make

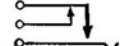

Fig. D
One Make
Before Break

The above contact spring arrangements represent the normal or unoperated contact spring position of the keys listed below.

Lever Type Keys—No. 479

LOCKING TYPE

Locking in one or both positions

Code No.	No. of Contacts	Contact Spring Arrangement							
		Position 1 Figures				Position 2 Figures			
		A	B	C	D	A	B	C	D
479B	10	2	2
479F	5	1	1
479G	8	2	2
479H	12	2	2
479K	12	2	2	..
479AP	5	1	1	..
479AU	12	4	..
479AW	20	2	..	2	..	2	..	2	..
479AY	6	2
479BN	24	4	4	..

NON-LOCKING TYPE

Non-Locking in one or both positions

Code No.	No. of Contacts	A	B	C	D	A	B	C	D
479AD	6	2
479BD	8	2	2
479CG	14	1	..	2	2	..
479CS	12	2	2	..

COMBINATION LOCKING AND NON-LOCKING TYPES

Code No.	No. of Contacts	Locking				Non-Locking			
		A	B	C	D	A	B	C	D
479D	14	2	1	1	..	2	..
479E	12	2	1	..	2	..
479T	8	1	1	..
479AK	12	2	2	..
479CH	16	1	1	2	2	..
479CM	12	..	2	1	2
479FC	14	..	1	2	2	..

KEYS

Lever Type Keys—Continued

NO. 501 TYPE

The No. 501 Key is a lever type key similar in construction to the No. 479 Type but arranged for mounting in the universal type of keyshelf; also may be used for general purposes. Keys are equipped with black handles and may be obtained with various spring combinations. Moving lever forward operates rear set of springs and vice versa. Mounting screws are furnished.

NO. 510 TYPE

The No. 510 Type Keys are for use in Western Electric switchboards employing Harmonic Ringing Systems.

Replaces No. 468 Type Key for new and additional equipments.

When ordering No. 468 Type Keys for replacement purposes the code number of the key now used should be given. This number is stamped on the frame of each key. Our factory will then either make shipment, or suggest a suitable No. 510 Type Key if advisable. Consists of four-party restoring type harmonic ringing key unit and a lever key unit mounted in a base $7\frac{3}{16}$ inches long having a hard rubber key top $5\frac{1}{4} \times .840$ inches.

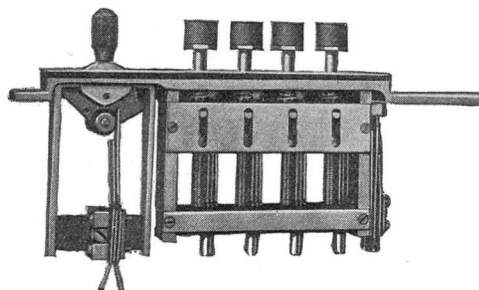

No. 510 Type Key

Code No.

Description

510A For use as a one-way, individual, four-party manual ringing key with listening combination arranged for circuits with flashing recall on both cords.

Mounted Type Keys

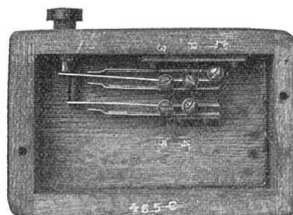

No. 465C. Bottom View

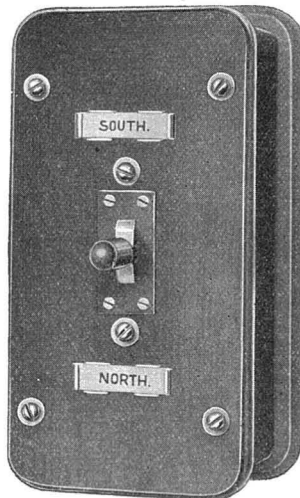

No. 6000B

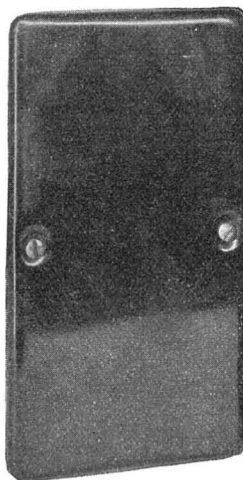

No. 6017E—Cover Removed

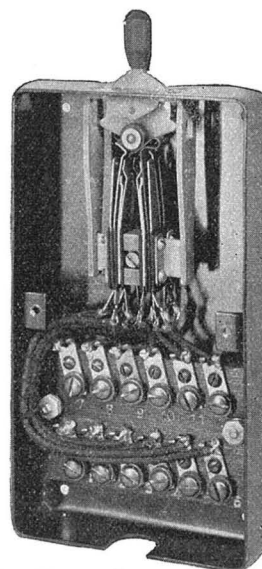

KEYS

Mounted Type Keys—Continued

Code No.	Description
465A	Push button type key mounted in oak box. Size of box $4\frac{11}{16} \times 3\frac{1}{16} \times 1\frac{13}{32}$ inches. Non-locking. Makes three and breaks one contact when operated.
465C	Non-locking. Makes two and breaks one contact when operated. Similar to No. 465A.
465D	Non-locking. Makes one and breaks one contact when operated. Similar to No. 465A.
465E	Non-locking. Makes three and breaks two contacts when operated. Similar to No. 465A.

NO. 6000 TYPE

6000A	Wooden box equipped with one No. 377A Key and one No. 6A Key Lever. Size of box (including key lever) $4\frac{3}{4} \times 3\frac{5}{8} \times 1\frac{13}{16}$ inches. Locking. Makes two contacts when operated. For use in dispatcher's telephone circuits.
6000B	Wooden box (No. 334 Key Mounting) equipped with one No. 136B Key. Size of box $6\frac{1}{4} \times 3\frac{5}{16} \times 2\frac{7}{16}$ inches. Locking in both positions. Makes two and breaks two contacts in both positions when operated. For use in railroad service for connecting a telephone to any one of three separate lines.

NO. 6017 TYPE

The No. 6017 Type Key consists of a key unit, equipped with a P-132717 Hard Rubber Handle, and connecting block, mounted in a black finished metal box. Overall dimensions: length $7\frac{1}{2}$ inches; width $3\frac{3}{16}$ inches; depth $1\frac{3}{16}$ inches.

A red, white or black colored lever handle may be obtained. Unless otherwise specified in the order the standard color of the handle noted below will be furnished.

The No. 6017 Type Keys replace the No. 6002 Type of corresponding code letter.

Code No.	Key Unit No.	Lever Handle	Spring Combination	Intended for Use as
6017-A	2-BF	Red	Locking-Locking	Switching key to connect a telephone instrument on either one or both of two lines.
6017B	2-GP	Black	Locking	Switching key to connect a telephone instrument on either one of two lines.
6017C	2-F	Black	Non-Locking	Ringing key at substations.
6017D	2-CL	Black	Locking	Switching key. Makes three and breaks three contacts (acts same as a 3 pole, double throw switch).
6017E	2-GR	Black	Locking-Locking	Switching key. Makes two and breaks two contacts when the lever is thrown to the left or to the right.

No. 6021 Type Push Button Keys

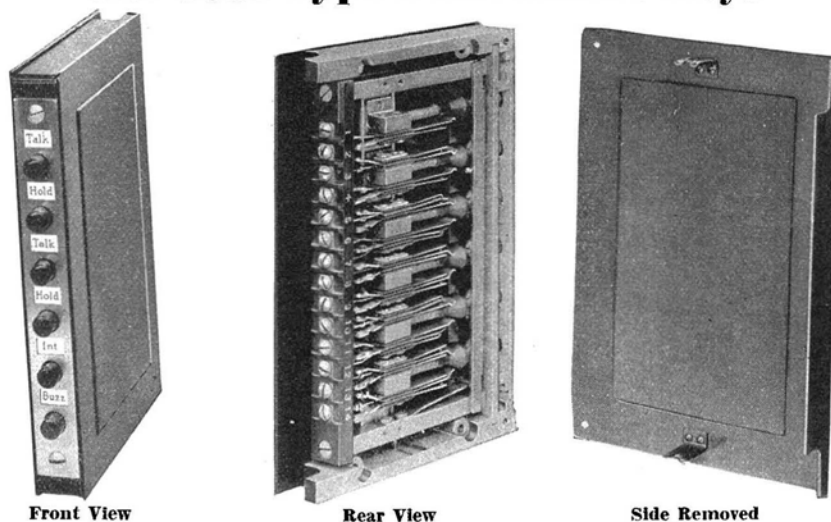

KEYS

No. 6021 Type—Continued

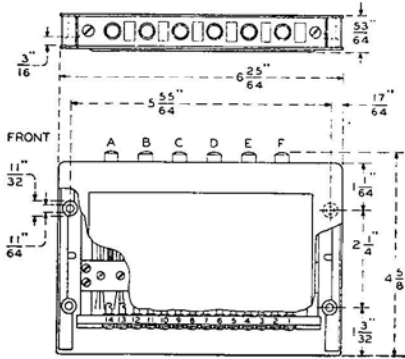

Dimensional Drawing

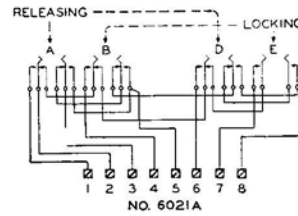

NO. 6021A

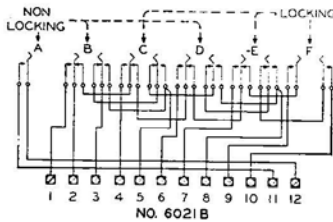

NO. 6021B

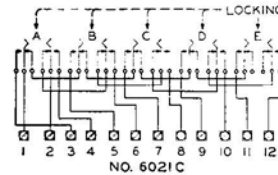

NO. 6021C

The No. 6021 Type Keys are intended for use at subscriber stations in connection with various station wiring arrangements. Each key consists of a key unit enclosed in a black finished metal box and is equipped with push buttons as indicated below and a terminal strip to which the contact springs are strapped for outside connection. Designation card frame is provided above each button.

The locking push buttons when depressed release any locked button and remain locked in the operated position. The releasing push buttons when depressed release any locked button and return to normal position. The non-locking push buttons do not release any locked button and return to normal position.

The box may be reversed with respect to the key unit in order to permit mounting on either the right or left side of a desk or table. The box has a snap-on cover and is provided with two holes for cable entrance.

The overall dimension of the 6021 Type Key is length $6\frac{25}{64}$ "; width $5\frac{55}{64}$ "; depth $4\frac{5}{8}$ ".

Code No.	Push Buttons						Replaces No.
	A	B	C	D	E	F	
*6021A-3	Red	Black	—	Red	Black	—	6009A
*6021B-3	Yellow	Red	Black	Red	Black	Black	6009B
6021C-3	Black	Black	Black	Black	Black	—	6009C

* Equipped with platinum contacts.

KEYS—Continued

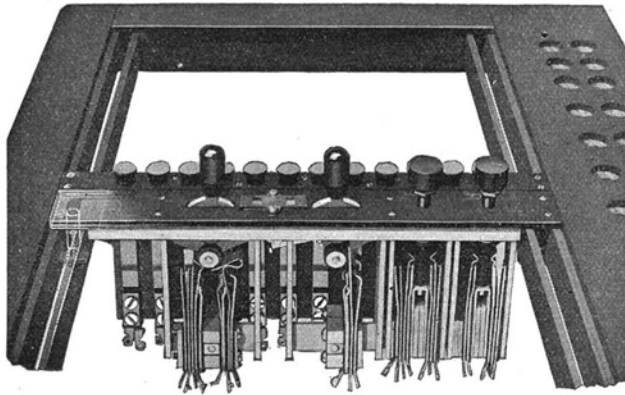

A2 and A3 type keys in universal key shelf

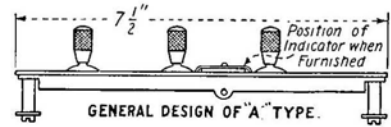

GENERAL DESIGN OF "A" TYPE.

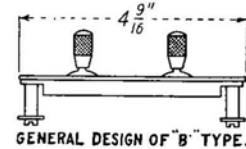

GENERAL DESIGN OF "B" TYPE.

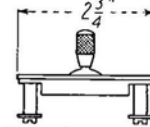

GENERAL DESIGN OF "C" TYPE.

UNIVERSAL TYPE KEYS

Universal type keys are arranged to mount in a Universal type keyshelf, which, instead of being drilled and tapped for a definite location for each key, is provided with two mounting slots running lengthwise of the keyshelf and registering with a mounting stud at each end of the key as shown in the illustration above.

In coding these Universal keys they have been divided into three types according to the length of the base: A type, 7½ inches; B type, 4¾ inches; C type, 2¾ inches.

All of these types of keys are made in a variety of models mounting lever key units, and push button key units in varying numbers and combinations.

Key units are supplied mounted with or without indicators which show the last key operated. The units are manufactured in non-locking form and the lever units in both locking and non-locking arrangements.

Universal type keys of the same length base will mount in any keyshelf designed for that length of key and apparatus blanks can be supplied either to take the place of keys at non-equipped positions in the switchboard, or to fill the space remaining in the Universal keyshelf after the required keys have been placed in it.

Several hundred forms of the Universal key are available, and it is, therefore, not practicable to list them all in this catalog. For detailed information regarding these keys refer to our Distributor.

The Universal type keys shown below are not complete or comprehensive and are not intended to be a guide in the selection of the actual keys required, but will serve for identification of Universal key types referred to in switchboard specifications or proposals.

Western Electric equipment using this type of key will be found to contain complete information for obtaining replacement, and in placing orders for this purpose, or for extension to the existing equipment, the customer should refer to the code number, which is stamped upon the keys already in service, or to the information given in the drawings accompanying the equipment.

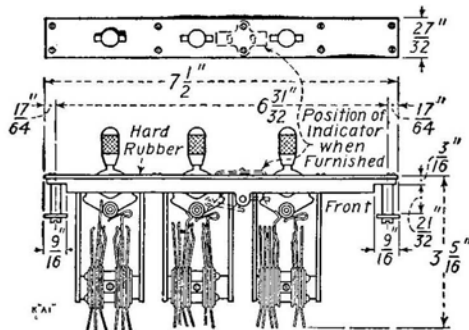

General Design and Dimensions of "A1A" Type

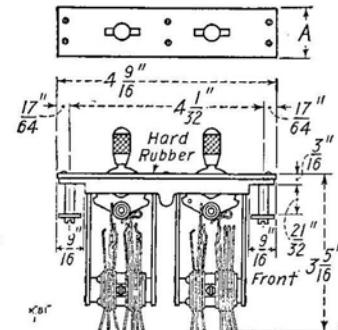

General Design and Dimensions of B-1C Type

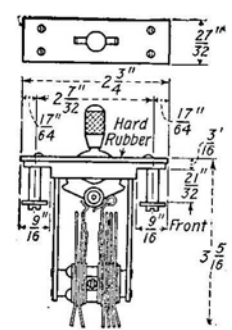

General Design and Dimensions of C-1A Type

Key Levers



No. 6A

Code No.	Operated Position of Lever	Description
6A	Vertical	Used with lever type keys. Black handle, metal parts nickel plated. Locking.
14A	Horizontal	Otherwise same as No. 6A.
23A		This is a double throw lever, locking in all positions and is used with lever type keys. When the lever is in the vertical position, all contacts are open; when the lever is thrown to the left the inner contacts are closed, and when the lever is thrown to the right the outer contacts are closed.



No. 23A

KEY MOUNTINGS

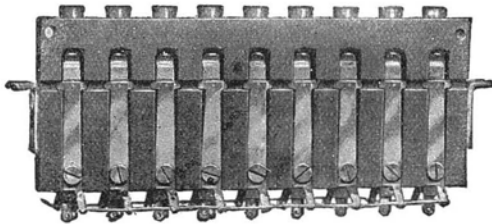

Side View of No. 69A Keys Mounted in a Typical Key Mounting

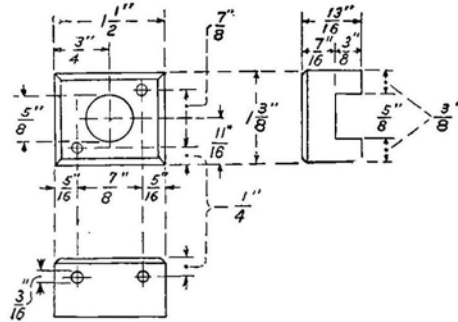

No. 360 Key Mounting

A complete line of Mountings arranged for use with any of our standard keys are manufactured; further information will be supplied upon request.

Also refer to listings under "Group Mounted Type" Keys.

Code No.	No. of Keys per Strip	Size of Top Inches	Keys Used With
235	10	$9\frac{3}{16} \times \frac{1}{2}$	69A
320	20	$10\frac{1}{2} \times \frac{7}{16}$	248A
338	10	$7\frac{23}{32} \times \frac{3}{8}$	490A
339	20	$7\frac{23}{32} \times \frac{3}{8}$	490A
340	10	$9\frac{3}{16} \times 1$	92 & 424 Types
342	20	$9\frac{3}{16} \times \frac{7}{16}$	492A
343	20	$9\frac{3}{16} \times \frac{1}{2}$	492A
344	4	$7\frac{23}{32} \times \frac{7}{16}$	492A
376	10	$11\frac{3}{16} \times \frac{1}{2}$	69A
378	5	$7\frac{23}{32} \times 2\frac{1}{4}$	{5-377A 5-1B Number Plates

The following Key Mountings are made of black finished wood and are for mounting push buttons $\frac{5}{8}$ inch in diameter and not over $\frac{3}{4}$ inch long, for use in signalling between substation extensions.

Code No.	Push Buttons per Mounting	Dimensions, Inches
360	1	$1\frac{1}{2} \times 1\frac{3}{8}$
361	2	$2\frac{3}{4} \times 1\frac{3}{8}$

Key Spaces

These are intended for use in place of keys where the full equipment of keys for which the keyshelf is arranged is not installed or to fill in space between two keys. Key Spaces can be furnished which correspond to our standard keys in respect to the size and finish of the top.

The following list represents a few of the most commonly used Key Spaces.

Code No.	Size of Top Inches	Corresponding Key	Code No.	Size of Top Inches	Corresponding Key
A5A	$7\frac{1}{2} \times \frac{3}{32}$	A1 Type	A27A	$7\frac{1}{2} \times \frac{27}{32}$	A1 Type
A6A	$7\frac{1}{2} \times \frac{3}{16}$	A1 Type	B33A	$4\frac{9}{16} \times \frac{11}{32}$	B1 Type
A12A	$7\frac{1}{2} \times \frac{3}{8}$	A1 Type	C27A	$2\frac{3}{4} \times \frac{27}{32}$	C Type
A13A	$7\frac{1}{2} \times \frac{13}{32}$	A1 Type	E24A	$11\frac{1}{16} \times \frac{3}{4}$	E Type
A21A	$7\frac{1}{2} \times 2\frac{1}{32}$	A1 Type			

Key Units

NO. 2 TYPE

We have available No. 2 Type Key Units which are the same in operation as the No. 479 Type Keys described on the preceding pages of this catalog, except that they are arranged for rear of panel mounting instead of face of panel mounting, the face plate as shown on the No. 479 Type Keys being omitted. For further information regarding these Key Units write our nearest distributor.

LAMPS



No. 2

The manufacture of switchboard Lamps is a highly refined and specialized art. The Western Electric Company has been active in this field for many years and the problems involved have been studied continuously and extensively in its Research and Engineering Laboratories. Methods of manufacture and special treatments for filaments have been perfected which give the Lamps long life, uniform quality and high illuminating power. A bright, dependable signal can only be obtained by the use of a Lamp of the best quality. Western Electric Lamps represent the latest development of the art and will give the highest class of service.

The following switchboard Lamps are $1\frac{3}{4}$ inches in length and .3075 inch (approximately $\frac{5}{16}$) in diameter. The bulb is made from clear glass and is tipless.

Every Lamp is tested for current consumption and for illuminating power.

Carbon Filament Lamps

These Lamps are intended for use with Nos. 12, 30, 34 or similar type lamp sockets.

Code No.	Voltage	— Current Consumption —		Code No.	Voltage	— Current Consumption —	
		Minimum Amperes	Maximum Amperes			Minimum Amperes	Maximum Amperes
2C	15	.103	.120	2K	30	.09	.12
2E	20	.09	.12	2R	18	.09	.12
2F	12	.105	.120	2T	40	.034	.046
2G	24	.075	.115	2U	24	.035	.0475
2J	24	.018	.033	2W	18	.035	.045
				2Y	48	*.025	*.035

* Current at 40 volts.

Tungsten Filament Lamps

These Lamps are intended for use with Nos. 12, 30, 34 or similar type lamp sockets.

Code No.	Voltage	— Current Consumption —			Code No.	Voltage	— Current Consumption —		
		Minimum Amperes	Maximum Amperes	Replaces			Minimum Amperes	Maximum Amperes	Replaces
A1	24	.033	.045	..	E3	6	.12	.16	2N
A2	24	.075	.105	..	F1	4	.17	.21	2A
B2	18	.036	.048	..	F2	4	.27	.31	2B
C2	36	.032	.044	..	G1	8	.085	.10	2P
E1	6	.033	.045	..	H1	16	.27	.31	2D
E2	6	.27	.31	2H	J1	10	.23	.27	2L

The No. 2 Lamps are now standard for use in the No. 16 Type Lamp Sockets instead of the No. 4 Lamps previously used. To permit of this, an adapter has been designed which may be inserted into the mounting through the lamp cap opening. The No. 2 Type Lamp together with a sufficient number of adapters should be ordered when replacements of No. 4 Type Lamps are to be made. In ordering specify:

Lamp Socket Adapter per D-12279

LAMP CAPS



No. 2C

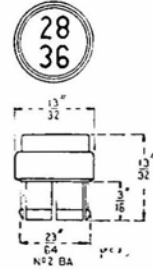
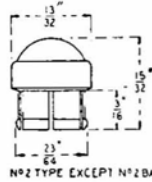

The lenses of Western Electric Lamp Caps are thick and substantial, being made from specially selected and treated glass. These lenses are held firmly in place in the cap cases by spinning the edges over the lenses. The cases are slotted to give a spring fit for the cap in a socket.

NOS. 2 AND 72 TYPE—USED WITH NOS. 12 AND 13 LAMP SOCKETS
DIAMETER $\frac{13}{32}$ INCH

Code No.	Symbol	Color	Code No.	Symbol	Color
2A	⊖	White opalescent	2AF	⊕	White opalescent
2B	⊙	White opalescent	2AG	⊗	White opalescent
2C	⊕	White opalescent	2AH	⊖	White opalescent
2D	⊙	White opalescent	2AJ	⊖	White opalescent
2E	⊖	White opalescent	2AK	⊖	White opalescent
2F	⊙	White opalescent	2AL	⊙	Green opalescent
2G	⊕	White opalescent	2AM	⊖	White opalescent
2H	⊖	Red opalescent	2AN	⊖	White opalescent
2J	⊗	White opalescent	2AP	⊗	White opalescent
2K	⊖	White opalescent	2AS	⊖	White opalescent
2L	⊖	Green opalescent	2AT	⊖	White opalescent
2M	⊕	White opalescent	2AU	⊕	White opalescent
2N	⊙	Red opalescent	2AW	⊕	White opalescent
2P	⊙	Jeweled red	2AY	⊖	White opalescent
2R	⊙	Jeweled blue	2AZ	⊕	Red opalescent
2S	⊙	Jeweled green	2BA*	⊕	White opalescent
2T	⊕	Red opalescent	2BC	⊖	White opalescent
2U	⊖	Amberopalescent	2BD	⊖	White opalescent
2W	⊖	Blue opalescent	2BE	⊕	Green opalescent
2Y	⊙	Green opalescent	2BF	⊖	White opalescent
2Z	⊖	White opalescent	2BG	⊖	Green opalescent
2AA	⊖	Red opalescent	2BH	⊖	Green opalescent
2AB	⊖	White opalescent	2BJ	⊖	White opalescent
2AC	⊙	Red opalescent	2BN	⊖	Clear
2AE	⊖	Red opalescent	2BP	⊙	Clear Amber

* Numbered as specified in order. Lens has flat top.

LAMP CAPS—Continued

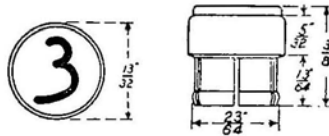

No. 72 Type (Translucent Numbers On Black Background Except Nos. 72L, M and N, Which Have White, Red and Green Backgrounds With Black Characters)

Used with Nos. 12 and 13 Type Lamp Sockets:

Code No....	72A	72B	72C	72D	72E	72F	72G	72H	72J	72K	72L	72M	72N
Symbol....	0	1	2	3	4	5	6	7	8	9	*	*	*



* Characters as specified in order. One, two, or three characters will be arranged on one line, four characters on two lines.

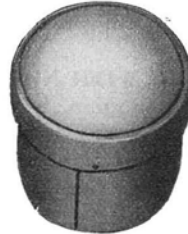

No. 4A

**NO. 4 TYPE—USED WITH NOS. 16, 32, 33 AND 34 LAMP SOCKETS
OVERALL DIAMETER 37/64 INCH**

Used in the No. 34 Lamp Socket for all such special cases as pilot signals, fire alarms, supervisor's signals, and for other classes of work in which the mounting of a large signal is desirable.

Code No.	Symbol	Color	Code No.	Symbol	Color
4A	○	White opalescent	4D	○	Red
4B	⊗	Jeweled red	4F	○	Green
4C	⊗	Jeweled green	4G	⊕	White opalescent



No. 8 Type, Except Nos. 8C, BA, BB and BD

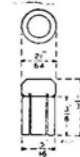

Nos. 8C, BA, BB and BD

NO. 8 TYPE—USED WITH NO. 30 LAMP SOCKET, OVERALL DIAMETER 2 1/64 INCH

Code No.	Symbol	Color	Code No.	Symbol	Color
8A	○	White opalescent	8Y	⊗	Green opalescent
8B		Clear	8AA	⊖	Red opalescent
8D	○	Red opalescent	8AC	⊗	Red opalescent
8E	⊙	White opalescent	8AS	⊖	Green opalescent
8F	⊙	White opalescent	8AU	⊕	White opalescent
8G	⊖	White opalescent	8AY	⊕	White opalescent
8H	⊖	White opalescent	8BC	⊙	White opalescent
8J	⊕	White opalescent	*8BD	⬤	White opalescent
8L	○	Green opalescent			

* White opalescent painted black except for raised bar across the face.

Lamp Sockets



No. 13

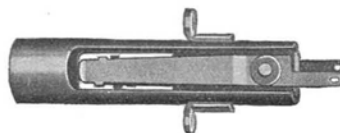

No. 34

Mounted Singly

These sockets are made of brass and are supplied with nickel silver springs, which are insulated with hard rubber. They mount individually and can, therefore, be ordered entirely separate from their mountings. The springs are insulated from the frame. The lamp mounts close to the lens of the lamp cap, giving the greatest possible amount of useful illumination.

Code No.	Used with Lamp No.	Used with Lamp Cap No.	Used with (Thickness of Shelf in Inches)
13	2	2 & 72	$\frac{7}{8}$ inch
34	2	4	$\frac{7}{8}$, 1, $1\frac{3}{16}$, $1\frac{1}{4}$, $1\frac{3}{16}$ inches
41A	2	2 & 72	$\frac{5}{8}$ inch

Mounted in Strips

These sockets are made of brass, and have nickel silver springs with hard rubber insulation. They are equipped in mountings containing 5, 10 or 20 sockets per strip and will not be supplied as a separate item, but must be ordered in connection with lamp socket mountings. (See description under Lamp Socket Mountings.)

Code No.	Used with Lamp No.	Used with Lamp Cap No.	Suitable for Lamp Socket Mounting No.
30	2 Type	8	102, 118, 123, 125

Lamp Socket Mountings

In ordering, specify the number of lamp sockets and the code number, together with the code number of the lamp socket mounting. The proper number of lamp sockets should be ordered to fully equip the mountings.

Lamp socket mountings when equipped with No. 12 Lamp Sockets may have numberings stamped on the face of the strip, if desired, but will be furnished unnumbered unless otherwise specified in the order.

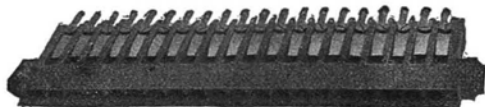

No. 12 Lamp Socket with No. 102 Mounting



No. 12 Lamp Socket with No. 136 Mounting



No. 12 Lamp Socket with No. 137 Mounting

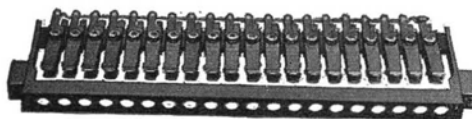

No. 30 Lamp Socket with No. 102 Mounting

Not Arranged for Number Plates

Code No.	Arranged for Lamp Sockets Nos.	No. per Strip	Face Dimensions, Ins.		Will Mount with Jack Mountings Nos.	Type of Switchboard Used with
			Length	Width		
**102	12 and 30	20	$9\frac{3}{16}$	$\frac{3}{16}$	118 and 120	No. 1
105	12 and 30	10	$7\frac{21}{32}$	$\frac{3}{16}$	64 and 86	
**123	12 and 30	20	$10\frac{1}{2}$	$\frac{3}{16}$	115	No. 9
**125	12 and 30	10	$10\frac{1}{2}$	$\frac{3}{16}$	116 and 115	
136	12	10	$11\frac{3}{16}$	$\frac{3}{16}$	108, 109 and 110	No. 1962, No. 10
137	12	20	$11\frac{3}{16}$	$\frac{3}{16}$	108 and 112	No. 1962, No. 10
***138U	12	12	$6\frac{7}{8}$	$\frac{1}{2}$		

** The mounting is made of hard rubber when supplied with No. 12 Lamp Sockets and is of metal when used for No. 30 Lamp Sockets.

*** Mounts with "A3" Keys.



No. 122 with No. 12 Lamp Socket



No. 134 with No. 12 Lamp Socket

Arranged for Number Plates

Code No.	Arranged for Lamp Sockets Nos.	No. per Strip	Face Dimensions, Ins.		Arranged for Plates Nos.	Will Mount with Jack Mountings Nos.	Type of Switchboard Used with
			Length	Width			
122	12	10	$9\frac{3}{16}$	$\frac{3}{16}$	31A, 59B	1, 2, 21	No. 1
132	12	10	$10\frac{1}{2}$	$\frac{3}{16}$	31A, 59B	116	No. 9
134	12	10	$7\frac{23}{32}$	$\frac{3}{16}$	60D, 108A	18, 19	No. 1

LINE POLES

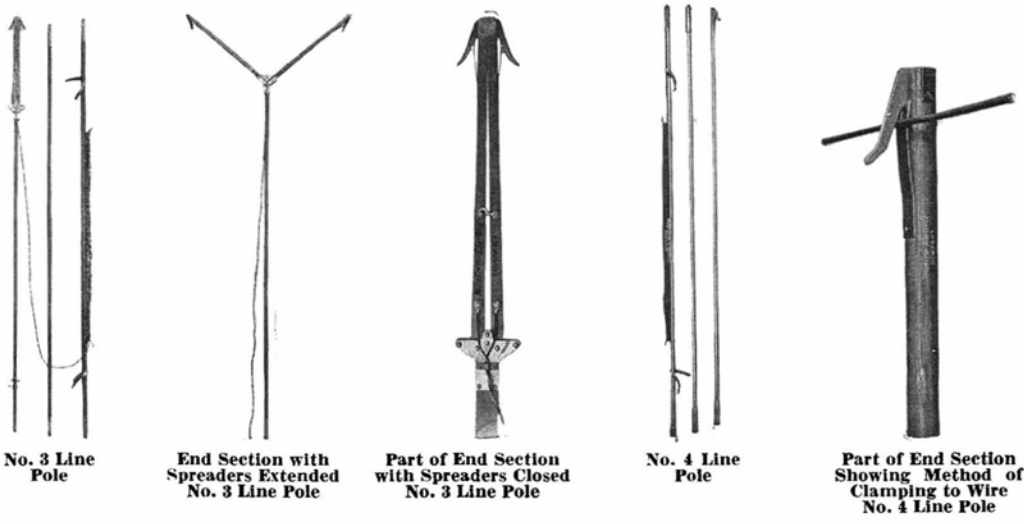

No. 3 Line Pole

End Section with Spreaders Extended No. 3 Line Pole

Part of End Section with Spreaders Closed No. 3 Line Pole

No. 4 Line Pole

Part of End Section Showing Method of Clamping to Wire No. 4 Line Pole

The line poles here listed are intended primarily for connecting portable telephones to open wire lines. They are made of hardwood and are in three sections, each approximately 6 feet in length. The joints are made of seamless brass tubing and are arranged so that the sections are securely locked together when the line pole is in use. The poles are so designed that the middle joint may be omitted if desired, thereby reducing the length of the line pole from 18 to 12 feet.

Contact with the line wires is made by means of a connecting clamp which consists of a metal hook equipped with a spring. When the hook engages the line wire the spring forces the wire into contact with the hook and at the same time scrapes the wire slightly so that a good contact is obtained.

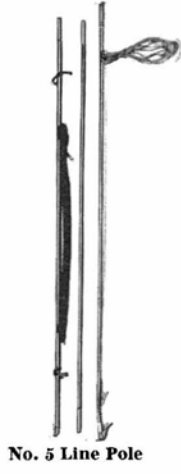

No. 5 Line Pole

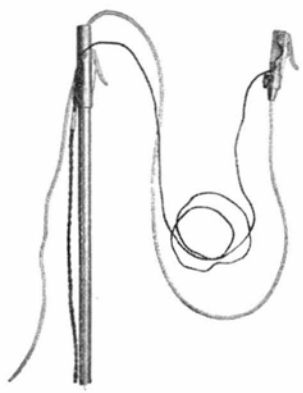

Part of End Section Showing Free Clamp. No. 5 Line Pole

Code No.	For Making Contact with	Cord	Description
3	2 metallic conductors.	100 feet of M2J two conductor cord. For use with 1330-E, 1331-E, 1332-A & E Telephones.	The top section is equipped with two arms hinged at the lower end. These are each equipped with a connecting clamp and are of such length that they will span wires spaced up to 2 feet horizontally.
4	1 metallic conductor (grounded line)	100 feet of M1A one conductor cord. For use with 1314-A Telephones.	The top section has one connecting clamp only.
5	2 metallic conductors.	100 feet of M2K two conductor cord. For use with 1330-E, 1331-E, 1332-A & E Telephones.	The top section is equipped with two connecting clamps. One of these is fixed to the pole and the other free but under control of the user by means of a long cord. This is intended for making connections between two line wires spaced up to 5½ feet, either horizontally or vertically.

MESSAGE REGISTERS AND COUNTERS

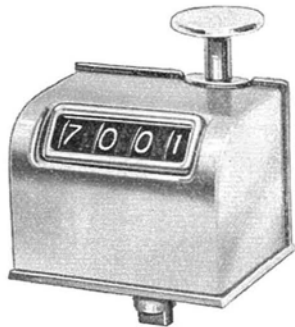

No. 10A



No. 12004

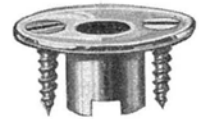

No. 12005

Manually Operated Counters

This mechanically operated, nickel-finished message register is primarily designed for making traffic peg counts. It is 1 7/8 x 1 1/4 inches at the base, and mounts in a socket which is flush in the top of the switchboard keyshelf or the socket can be supplied mounted in a portable mahogany finished base (2 3/4 x 2 1/4 inches). The mechanism is strong and compact. The plunger being on the top of the case, is easily located by the operator and its action when depressed clearly indicates when the register has counted. The numbers appear in white on a black background and are easily read. The counter is of the cumulative type, registering up to 9,999 and then repeating, and it cannot be reset. This non-resetting feature increases the accuracy of readings through the elimination of errors in setting and also saves time in operating.

Code No.	Description
10A	Message register (counter only).
12004	Portable base for No. 10-A Message Register.

Code No.	Description
12005	Flush socket for permanently mounting No. 10-A Message Register.

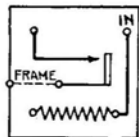

FIG. 1

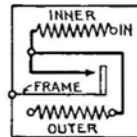
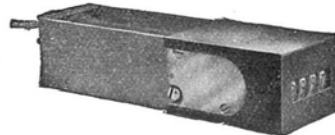

FIG. 2



No. 5L

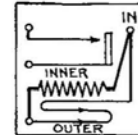

FIG. 3

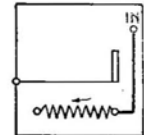

FIG. 4

Electrically Operated Registers

Electrically operated counters, primarily designed for use in connection with special central office circuits, and usually operated by means of a push button key mounted in the switchboard keyshelf.

The Nos. 5H and 5AC are designed for use in making peg counts, and the No. 5L is designed for association with an individual subscriber's line, and when so used is controlled by the switchboard operator to register the number of calls over that line.

The Nos. 5H and 5L may be arranged so as to give simultaneous peg count service and individual line call registering.

These message registers mount on steel mounting plates as listed under the heading of "Mounting Plates." The overall dimensions are 5 7/8 inches long (including terminals), 1 3/16 inches high and 1 1/2 inches wide.

Code No.	Windings	Rated Resistance (Ohms)	Operates On	Non-Operate On	Wiring Fig. No.
5H	Single	.27	1.4 amps.	1.25 amps.	Fig. 1 (Frame Connection)
5L	{ Inner	37.5	*25.5 volts	23.9 volts	Fig. 2
	{ Outer	463.			
5M	Single	280.	.036 amp.	.032 amp.	Fig. 1 (No Frame Connection)
5S	Single	5.	.313 amp.	.271 amp.	Fig. 4
5T	Single	1000.	.028 amp.	.023 amp.	Fig. 4
5U	Single	1000.	.028 amp.	.023 amp.	Fig. 1 (Frame Connection)
5AA	Single	6000.	.012 amp.	.0108 amp.	Fig. 4
5AC	{ Inductive	355.	**.065 amp.	**.055 amp.	Fig. 3
	{ Non-Inductive	600.			
	{ Combined	223.			

Notes. * With both windings in series. ** Through primary and secondary in multiple.

MOUNTING PLATES

The term "Mounting Plates" refers in general to a milled steel plate arranged for mounting relays, resistances, condensers and message registers. These Mounting Plates must not be confused with mountings for drops, keys, lamp sockets, etc., which are listed elsewhere under their respective titles.

Plates of different capacities and sizes other than those listed can be furnished; also plates arranged for mounting combinations of relays, resistances, etc., information on which will be furnished upon request.



Punched Frame Type



Drilled Plate Type

Mounting Plates for Relays

These Plates are available in punched frame and drilled plate types. All punched frame types are equipped with dust-proof covers and are recommended when individual relay covers are not furnished or where the relays are to be mounted in an exposed location.

Punched Frame Type—Relay Mounting

Galvanized finished metal plates $1\frac{3}{32}$ inches in width, with black finished dust-proof covers $3\frac{1}{2}$ inches in depth.

Code No.	Relays per Plate	Mounting Centers	Length, Inches	Arranged for Relays	Will Mount Interchangeably with Mtg. Plates
*737A	20	$\frac{3}{4}$	19	A, E, or F Types	600 Type
*737B	10	$1\frac{1}{2}$	19	A, E, F, or R Types	600 Type
737C	20	$\frac{3}{4}$	19	A, E, or F Types	600 Type
745A	24	$\frac{3}{4}$	$21\frac{5}{8}$	A, E, or F Types	606, 607 and 756
†745B	18	1	$21\frac{5}{8}$	A, E, F, or R Types	606, 607 and 756
750A	24	$\frac{3}{4}$	23	A, E, or F Types	602 Type
‡750C	20	1	23	A, E, F, or R Types	602 Type
‡750F	20	1	23	A, E, F, or R Types	602 Type

* Provided with battery and ground clips.

** May be ordered equipped with Nos. 25 or 26 Terminal Punchings. Replaces No. 737D.

† May be ordered equipped with Nos. 25 or 26 Terminal Punchings. Replaces No. 745E.

‡ The Nos. 750C and 750F are of the same construction except that the No. 750C has cover pulls and the No. 750F has no cover pulls.

The following Mounting Plates are black finished metal plates designed to mount Nos. 209 or 215 Type Relays and their associated No. 18 Type Connecting Blocks.

Code No.	Relays per Strip	Dimensions, Ins.	Mtg. Centers Inches	
823A	1	$2\frac{3}{32} \times 4\frac{1}{4} \times 7\frac{3}{32}$	—	Mounts vertically
823B	1			
884K	5	$19 \times 3\frac{15}{32} \times 7\frac{1}{32}$	$3\frac{1}{2}$	Mounts horizontally

MOUNTING PLATES—Continued

Drilled Plate Type—Relay Mounting

Black finished steel plates $\frac{1}{32}$ inch thick, not equipped with covers unless otherwise indicated. When ordering, specify the exact code number of relays to be mounted, as each position must be drilled for the particular relay specified.

Code No.	Relays per Plate	Mounting, Inches			May be Ordered Drilled for Relays
		Centers	Length	Width	
600A	10	$1\frac{3}{4}$	19	$1\frac{23}{32}$	Nos. 89, 101, 105, 108, 114, 118, 124, 163, 172, 174 and 198
606A	10	$1\frac{3}{4}$	$21\frac{5}{8}$	$1\frac{23}{32}$	Same as 600A
606S	16	$1\frac{1}{4}$	$21\frac{3}{8}$	$1\frac{23}{32}$	Nos. B, G, H, or J Types of Relays
606T	15	$1\frac{11}{32}$	$21\frac{5}{8}$	$1\frac{23}{32}$	B, G, H or J Types of Relays
*609B	12	$1\frac{3}{4}$	23	$1\frac{23}{32}$	Same as specified 600A
609K	17	$1\frac{1}{4}$	23	$1\frac{23}{32}$	Drilled as specified
627C	19	$1\frac{1}{4}$	26	$1\frac{23}{32}$	Drilled as specified
677Y	15	$1\frac{5}{8}$	27	$1\frac{23}{32}$	Same as specified for 600A. Has cover
677AB	22	1	27	$1\frac{23}{32}$	Nos. A or E Type Relays. Has cover
823A	1	..	$4\frac{1}{4}$	$2\frac{23}{32}$	Nos. 209A or 215A Relays—Mounts vertically
823B	1	..	$4\frac{1}{4}$	$2\frac{23}{32}$	Nos. 209A or 215A Relays—Mounts horizontally
829D	8	$1\frac{1}{4}$	$14\frac{1}{8}$	$1\frac{23}{32}$	Drilled as specified

* Recommended in place of No. 609A.

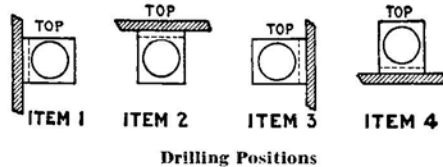
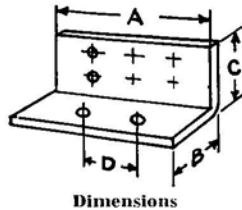

ANGLE TYPE—RELAY MOUNTING

Black Finished $\frac{1}{8}$ -Inch Steel

In ordering this angle type relay mounting plate, it is necessary to give the exact code numbers of both the mounting plate and relay to be mounted, also in which one of four positions the relay is to be mounted by specifying the particular item number shown above.

These plates are for all types of relays that come within the plate dimensions.

Code No.	No. of Relays	Dimensions, Inches			
		A	B	C	D
628A	1	$1\frac{23}{32}$	$1\frac{23}{32}$	$2\frac{23}{32}$	$1\frac{1}{4}$
628D	2	$1\frac{23}{32}$	$1\frac{25}{32}$	$2\frac{23}{32}$	$1\frac{1}{4}$
628E	3	$1\frac{23}{32}$	$1\frac{25}{32}$	$3\frac{1}{4}$	$1\frac{1}{4}$

Mounting Plates for Resistances

RELAY RACK TYPE

$1\frac{23}{32}$ Inches Wide

Code No.	Resistances per Plate	Mounting Centers	Length Inches	Mounts Resistances
601A	10	$1\frac{3}{4}$	19	Nos. 18 or 19 Types
601B	20	$\frac{7}{8}$	19	
*601C	40	$\frac{7}{16}$	19	
644A	20	$\frac{7}{16}$	$10\frac{3}{4}$	

* Recommended in place of No. 601D.

MOUNTING PLATES—Continued

Mounting Plates for Resistances—Angle Type

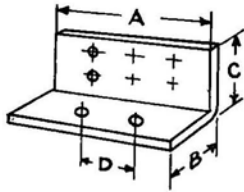

Dimensions

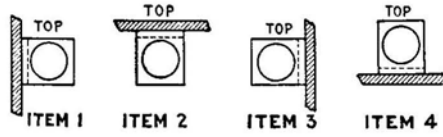

Drilling Positions

ANGLE TYPE

Black Finished— $\frac{1}{8}$ -Inch Steel

In ordering this angle type resistance mounting plate, it is necessary to give the exact code numbers of both the mounting plate and resistance to be mounted, also in which one of four positions the resistance is to be mounted by specifying the particular item number as shown above.

Code No.	No. of Resistances	Centers	Dimensions, Inches				For Resistances
			A	B	C	D	
*629A	5	$\frac{7}{16}$	$1\frac{23}{32}$	$1\frac{11}{16}$	$2\frac{23}{32}$	$1\frac{1}{4}$	19 Type
629C	8	$\frac{5}{8}$	$1\frac{23}{32}$	$1\frac{1}{8}$	$2\frac{23}{32}$	$1\frac{1}{4}$	1 Type
682A	$1\frac{23}{32}$	$1\frac{1}{8}$	$1\frac{1}{8}$	$\frac{21}{32}$	19 Type
**690F	8	$\frac{7}{16}$	$1\frac{23}{32}$	$1\frac{11}{16}$	4	$1\frac{1}{4}$	18 or 19 Type

* Recommended in place of No. 629B.

** Recommended in place of No. 873A.



Mounting Plates for Message Registers

RELAY RACK TYPE

Black Finished Steel Mounting Plates $\frac{3}{8}$ Inch Thick and $1\frac{1}{4}$ Inch Wide

Code No.	Registers per Strip	Mounting, Inches		Drilled for Message Registers
		Centers	Length	
*628A	1	No. 5 Type as required
671B	10	$1\frac{5}{8}$	19	No. 5H
671C	10	$1\frac{5}{8}$	19	Nos. 5L, 5S and 5T
785A	15	$1\frac{5}{8}$	27	No. 5 Type as required

* Angle tip mounting plate. Order for drilling positions as described under relay angle mounting plates.

Miscellaneous Mounting Plates

Code No.	Type	Dimensions, Inches	Use
937A	Drilled	$3 \times 14\frac{1}{4} \times \frac{1}{8}$	To mount 5 No. 221 Type Relays or No. 98A Repeating Coils, one No. 18 or No. 19 Type Resistances and two No. 34 Lamp Sockets.
943B	Drilled	$2\frac{7}{32} \times 19 \times \frac{7}{16}$	Used in pairs to mount 4 No. 77 Retardation Coils per pair.
943G	Drilled	$2\frac{7}{32} \times 19 \times \frac{7}{16}$	Used in pairs to mount ten Nos. 101, 102, 104 or 602 Type Balancing Networks per pair.
943K	Drilled	$2\frac{7}{32} \times 19 \times \frac{7}{16}$	Used in pairs to mount twenty No. 57N or similar Type Condensers per pair.

NUMBER PLATES



No. 1B



No. 5B



No. 23C

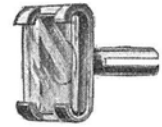

No. 30A

Code No.	Description	Size, Inches	Used in
*1B	White ivory with engraved black numbers; 1/4 inch high.	5/8 dia.	Wooden stile casings and panel numbers.
*5B	Hard rubber, black face, with white engraved characters 1/8 inch high.	1/2 x 5/16	110 Jack Mounting.
*12B	White ivory, black engraved characters; 5/32 inch high.	3/8 diam.	Plug shelves and key shelves to designate plugs and keys.
*21B	Hard rubber, black face with white engraved characters; 5/32 inch high.	1 1/16 x 3/16	135 Jack Mounting.
*23A	Aluminum plates with engraved black characters; 5/32 inch high. Escutcheon pins furnished for mounting. (1/4 inch figures when specified.)	25/32 diam.	Flat iron stile casings.
*23C			
*23D	Aluminum plate with engraved black characters; 5/32 inch high. Machine screws furnished for mountings.	25/32 diam.	Stile Strips.
**30A	Metal holders with a celluloid cover; furnished with numbers printed on paper sheets of 0 to 511, inclusive, etc., as specified in order.	3/8 x 1/4 1/16 x 3/16	Nos. 2, 6 and 17 Jack Mountings and Nos. 2C, 50A, 50B Designation Strips.
**31A			
59B	Hard rubber. Black face with white characters.	7/16 x 5/16	2 and 34 Jack Mountings.



No. 60D

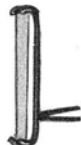

No. 108A



No. 128B

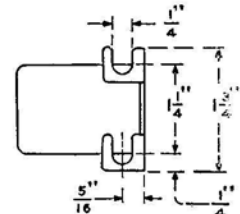

Dimensional Drawing of No. 146A

Code No.	Description	Size, Inches	Used in
*60D	Hard rubber, black face with white numbers; 1/8 inch high.	3/8 x 1/4	19 Jack Mounting.
*107B	Aluminum disc with a dull, satin finish and black characters; 1/4 inch high. Furnished with escutcheon pin for mounting.	1 1/32 diam.	Used on stile casings.
**108A	Metal number plate arranged to hold a strip of printed figures, black finish. Numbers are furnished as printed sheets of 0 to 511, inclusive, etc.	25/32 x 15/64	19 Jack Mountings.
126A	Marked "Out of Service."		Used in No. 50 Type Coin Collectors.
*127A	Metal, satin aluminum finish, black characters.	1 13/32 x 25/32	No. 4 Toll Test Boards.
128B	Metal, black finish, paper card with celluloid covering.	2 23/64 x 1 3/4	Face of transmitters.
146A	Metal plates.	1 3/4 x 1 3/4	On relay racks to designate bay.
146B	Metal plates.	1 1/4 x 1 3/4	On relay racks to designate bay.

*Engraved as specified in order.

**Numbers from 0 to 9727, inclusive, are furnished on printed sheets, 512 numbers to a sheet. Sheets desired must be specified in order.

For number plates for machine switching, telephone dials, see listing of "Dial Number Plates."

PLUGS

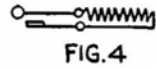
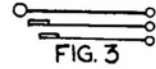
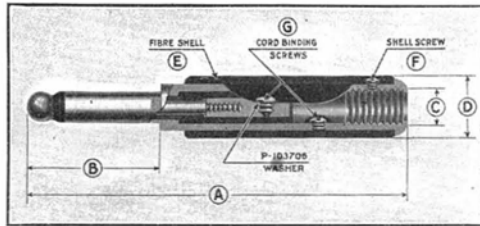
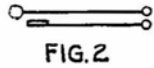
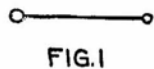
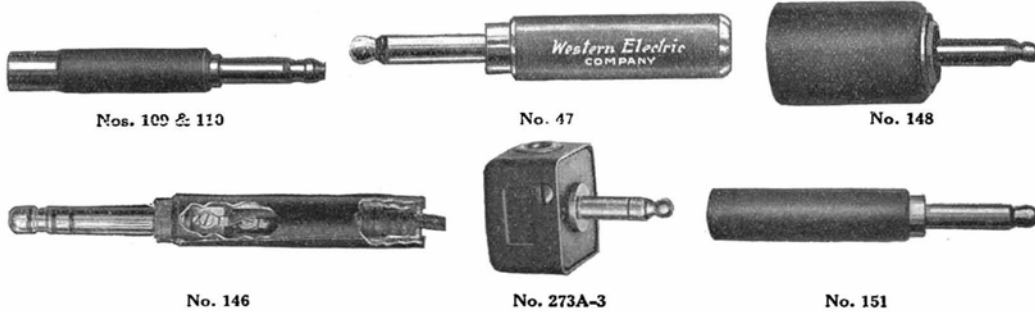

Dimensions and Replacement Parts

Code No.	Conductors	Dimensions				Used with Jack Nos.	Used with Cords	Notes	Replacement Parts (See Cut)		
		A	B	C	D				E	F	G
1A	Fig. 1	3 3/8	1 3/8	3/8	3/8	Same as for 47A Plug	511	{Shell Frame Fully Insulated	P-146711	P- 82233	P- 84662
3A	Fig. 2	3 3/8	1 3/8	3/8	3/8	Same as for 47A Plug	536		P-147704	P-162652	P-162653 & 4
47A	Fig. 2	3 3/8	1 3/8	3/8	3/8	225-227, 230-237, 281, 297, 303A, 309, 327, 353, 355, 361, 364	P2A, W2F, P1B, P2T, 768	{47A has Red Shell 47B has Black Shell	P- 81385	P- 82233	P- 82239
47B									P-110576	P- 82233	P- 82239
109	Fig. 3	3 1/2	1 3/4	3/8	3/8	92, 292, 246, 248, 249, 323, 358A, 49, 60, 70, 141, 259, 260, 274, 275, and Types 238-245, 267, 280, 284, 285, 289-291, 293, 295, 300, 308, 324, 326, 347, 358B, 359, 360, 362, 363, 365	S3A, S3B, P2B, W3C, W2C, S2B, S1B, P1C, P3E	*Has Red Shell	P- 81319	P- 81212	P- 82341
110	Fig. 3	3 3/8	1 3/4	3/8	3/4	Same as for 47 Plug	510, 511, 513, 519	*Has Red Shell	P- 81385	P- 82233	P- 84662
116	Fig. 1	3 3/8	1 3/8	3/8	3/8	Same as for 47 Plug	99, 162	Red Shell	P- 81335	P- 82233	P- 82239
136	Fig. 2	3 3/8	1 3/8	3/8	3/8	Same as for 47 Plug	369	Has Cord Bushing	P- 81335	P- 82233	P- 84662
144	Fig. 1	3 3/8	1 3/8	3/8	3/8	Same as for 47 Plug	W1A		P- 81200	P- 81299	P- 82341
145	Fig. 2	3 1/2	1 3/4	3/8	3/8	186	658, S2D		P- 143217	P-124071	P-127343
146	Fig. 2	3 1/2	1 3/4	3/8	3/8	Same as for 110 Plug	509	1330, 1331 Tel.	P-141633	P-124071	
150	3 3/8	1 3/4	3/8	3/8	Same as for 47 Plug	Nonrequired	For plugging out signals in lines in trouble	P-141307	P-123581	
151	3 3/8	1 3/4	3/8	3/8	Same as for 47 Plug	Nonrequired				
153A	Fig. 4	4 1/4	1 3/8	3/8	3/4	Same as for 47 Plug	Nonrequired	See Note 1	P-143232		
153B									P-143233	P- 81299	
153C									P-143234		
165	2 1/4	1 3/8	3/8	3/8	Same as for 47 & 116	S9B	See Note 2	P-113070	P-81299	P-82341
192	Fig. 3	3 3/8	1 3/4	3/8	3/4	Same as No. 110		Rubber lined Brass Shell	P-203388	P- 82233	P- 82239
221	Fig. 2	3 3/8	1 3/8	3/8	3/8	Same as for 47	{Same as for 47	Has large red insulating shell	P-238714	P-299033	
273A-3	Fig. 3	1 3/8	1	77, 78, 190		Replaces 148	P-218570	P-235305	P-82341
309	Fig. 3	3 3/8	1 3/8	3/8	3/8	Same as No. 109	Same as No. 109	Has Red Shell	P-218570	P-235305	P-82341
310	Fig. 3	3 3/8	1 3/8	3/8	3/8	Same as No. 110	Same as No. 110	Has Red Shell	P-218716	P-235303	P-82341

Note 1. The No. 153 Type Plug has a resistance unit connected so that when the plug is inserted in a jack the resistance unit is bridged across the tip and sleeve spring. The resistance unit will carry 1/10 ampere continuously without injury. The values are as follows: No. 153A Plug, 400 ohms. No. 153B Plug, 600 ohms. No. 153C Plug, 800 ohms. Used in Morse circuits for limiting the amount of battery current.

Note 2. No. 166 is a wooden dummy for opening jacks which use the Nos. 47 or 116 Plug.

* The following shells can be furnished for the Nos. 109, 110, 116, 309 and 310 Plugs when specified on order:

Plug No.	Gray Shell	Black Shell
109	P- 90065	P- 91143
110	P-107882	P-107872
116	P-110576
309	P-237244	P-237243
310	P-237246	P-237245

PLUGS—Continued

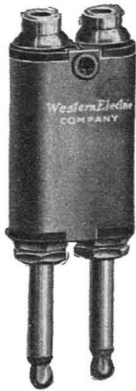

No. 137

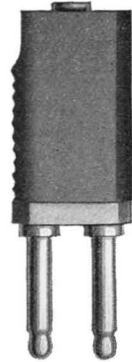
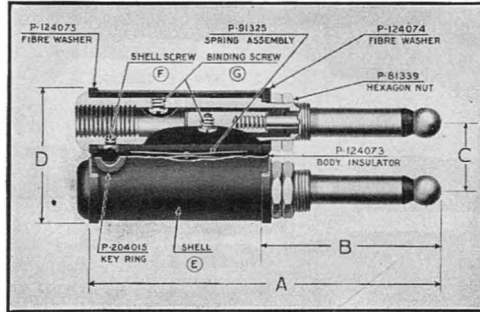

No. 241

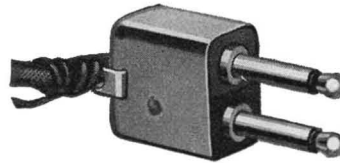

No. 246A

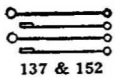

137 & 152

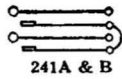

241A & B

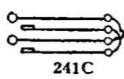

241C

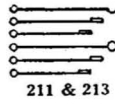

211 & 213

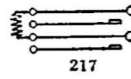

217

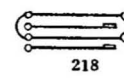

218

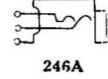

246A

Circuit Arrangements

TWIN PLUGS

When an operator's headset is to be used at a switchboard, it is convenient to wire two adjacent jacks for providing the necessary connections into the switchboard circuit and to use a twin plug in these two associated jacks in order that the necessity for the operator handling two separate plugs may be avoided. This practice is now standard and the Nos. 30, 78, and 80 Jack Mountings are designed for use with jacks so mounted that a twin plug may be inserted only in those jacks which are to be used together. These plugs include a self-adjusting or flexible feature which allows sufficient movement of each plug in the shell to take up any slight off-centering present in the jacks.

Code No.	Conductors (Each Plug)	Dimensions				Used with Jack Nos.	Used with Cords	Used for	Replacement Parts (See Cut)		
		A	B	C	D				E	F	G
137	2	3 1/16	1 3/16	5/8	1 15/64	99, 215-237, 281, 297	87, 371, 555, 562, 565, 745, 748, 749, 848, L2E, L3E, L3F, P4C.	Standard operator's head telephone	P-124076	P-124071	P-82239
152	2	3 5/16	1 3/16	{ 39/64 to 41/64 }	1 1/4	Same as 137	87, 550, 568, W2G, 674	Same as No. 137 but has ridges in shell to identify one side from other	P-142984	P-124071	P-82239
154	2	3 15/16	1 13/64	5/8	1 3/64	99, 236A, 236C, 236D, and Types 215 to 221 incl., 223, 225, 226, 227, 230 to 235 incl., 237, 281 and 297	S2G, S4A	Grooved to mark proper way of inserting plug in jack	P-211353	P-82233	P-82239
186	2	1 27/32	2 1/2	7/16	1 19/64	19C Test Set	747	19C Test Set	P-205776	P-158989
211	3	3 7/32	1 3/64	7/16	1 15/64	P-163952	P-81299	P-82341
213	3	3 7/32	1 3/64	1 1/16	1 3/16	49, 50, 70, 141, 259, 260, 274, 275, 295, 238-245	P-164090	P-81299	P-82341
217D	2	4 13/16	1 3/16	5/8	1 3/64	99, 215, 216, 217, 218, 223, 225, 226, 227 and 281 Types	See Note 1	P-167708	P-82233	P-82239
241A } 241B } 241C }	2	3 17/32	1 13/64	5/8	1 3/16	99, 297, and similar types	520, W3D, P3G, 855, P2T (See Note 2)	Black Shell Red Shell Black Shell Operator's Telephone Set	P-206009 } P-206010 } P-206009 }	P-229777
246A	2	2 11/16	1 3/16	5/8	1 5/16	215 or similar type	L4A	P-212688	P-82239

Note 1. The No. 217D has a resistance bridged across the tip springs.

Note 2. The No. 241 Type Plug has brass flanges of the two plugs electrically connected to the two plug sleeves; the tips are separately insulated.

PLUGS, PLUG SEATS AND PLUG TROUBLE CAPS



No. 13 Plug Seat

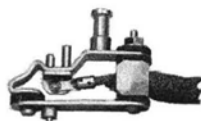

No. 252A Plug

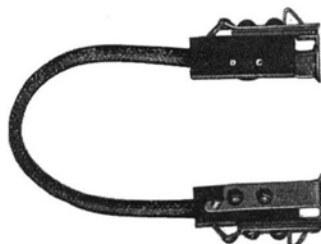

No. 135 Plug



No. 1A Trouble Cap

Test Plugs

Code No.	No. of Conductors	Ordinarily Used with Cords Nos.	Use	Notes
135	2	No. 76 Heat Coils and Nos. 89, 1168 and 1169 Type Protectors.	This plug is used at the protectors to reverse the polarity of a subscriber's line on which there is a ground on the ring side; the subscriber is given temporary service by battery feed over the tip side of the line.
234	4	838 839 841 842	No. 36 or similar type terminal strips.	Used in making connections with terminal strips on intermediate distributing frames. Replaces No. 132.
240A	4	Test jacks on Nos. 192, 193, 197 and 198 Type Switches having a corresponding number of springs. Nos. 348, 349A, 350A, 356A and 357A.	
252A	4	W4N W4P	Main distributing frames in manual and dial offices.	Intended for use with W4N and W4P Cords as Test Plugs in connection with protectors at main frames. Has "T" stamped on both sides of Plug. Replaces 206 and 225 Plugs.
252B	4	W4N W4P	Same as 252A.	Same as 252A, except that it has "R" stamped on both sides of Plug.

Plug Seats

These red fibre plug seats are furnished complete with No. 4 Round Head Wood Screws, 1/2 inch long, for mounting.

Code No.	Mount on Center, Ins.	Used with Plug Nos.
12	3/4	110
13	3/4	109
15	29/32	47
16	43-141
17	133

Plug Trouble Caps

Split fibre tubes, 1 inch long, which will slip over plugs. They are used as temporary markers for cord circuits in which there is trouble.

Code No.	Color	Used with Plug Nos.
1A	Black	109
1B	Red	109
2A	Black	47 and 110
2B	Red	47 and 110

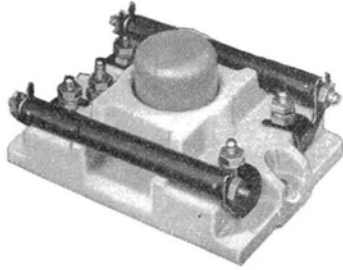
PROTECTORS

No. 98A Protector

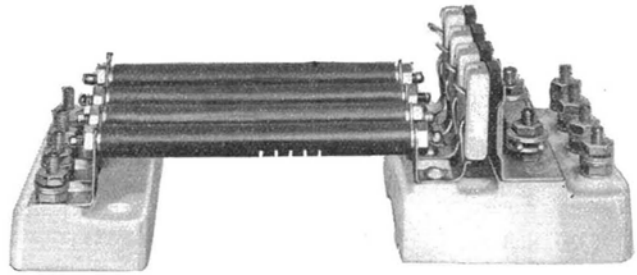

No. 1079AP Protector

Telephone Set Protection

Protection of central office and magneto telephone sets against lightning and abnormal electric currents is an important feature of telephone practice. The Protector must be simple in construction so that the parts can be easily replaced when necessary, and reliable in operation in order that it may give the desired protection when needed. Western Electric fuses act at one and one-half times their rated current values and open space cut-out Protectors will discharge across their air-gaps at a definite voltage value because of the accurate manufacture of the Protector Blocks.

The wide application of carbon block cut-out (air-gap) Protectors makes particularly important the use of Protector Blocks requiring minimum attention for renewal and cleaning. The following types of Protectors are designed to reduce maintenance and give the highest grade of protective service. Each Protector has a porcelain base and is equipped with our new design Nos. 26 and 27 Protector Blocks. These Blocks embody several advances in construction and operation as described in detail under "Protector Blocks."

Code No.	Line Protection	Consists of—			Protects Central Battery and Magneto Telephones Against
		Protector Mountings	Protector Blocks	Fuses	
62C	1-Wire	1 No. 50C	{ 1 No. 35A } { (1½ amp.) }	Abnormal currents.
62D	1-Wire	1 No. 22B	{ 1 No. 24A } { (1½ amp.) }	Abnormal currents.
76AP	2-Wire	{ 1 No. 29B } { Brass Cap P-143604 }	{ 2 No. 26 } { 2 No. 27 }	{ Same as 58AP, less Nos. 16 } { and 48 Protector Mountings } { and fuses. }
98A	2-Wire	{ 2 No. 26 } { 2 No. 27 }	2 No. 11C	{ High potential (lightning) and } { abnormal current. Replaces } { 58AP. }
**1079AP	4-Wire	{ 1 No. 79A } { 1 No. 80A }	{ 4 No. 26 } { 4 No. 27 }	{ 4 No. 11C } { (7 amp.) }	{ High potential (lightning) and } { abnormal currents for group } { mounting. Fuses mount on } { ⅜" center. Common con- } { necting ground strips are } { furnished for interconnect- } { ing two or more units. }

** Four No. 60A Fuses and one No. 80 Protector Mounting may be used with the No. 1079AP Protector as a sneak current arrester for private branch exchange protection.

PROTECTORS—Continued

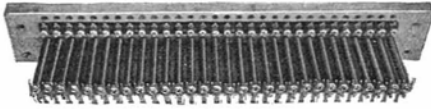

No. 1078A Protector

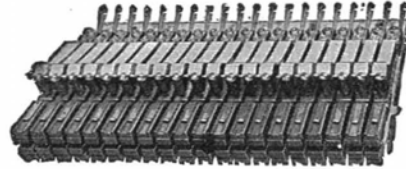

20 No. 1269A

Telephone Exchange Protection

These Protectors are designed for central battery and local battery exchange protection against high potential (lightning), abnormal and sneak currents, in accordance with the type selected.

NO. 1078 TYPE PROTECTOR

The No. 1078A Protector consists of a fuse mounting so designed that the fuses are mounted on $\frac{1}{16}$ inch centers. It is supplied in standard lengths of 42, 62, 82 and 102 Protectors per strip. The base of the Protector Mounting is designed to act as a fanning strip.

In ordering, the number of Protectors per strip should be specified, and if they are to be mounted on a distributing frame, sufficient information for the drilling desired should be given. If the frame is one which we have furnished and installed, the name of the exchange and the location of the Protectors on the frame will be sufficient.

Code No. **Consists of**
 1078A 1 No. 7A Fuse (7 ampere) and No. 78A Protector Mounting. (For one wire protection.) Specify number of Protectors per strip required.

NO. 1177A AND B TYPE PROTECTORS

The No. 1177A and B Type Protectors are high potential and sneak current arresters designed to mount on "B" Type main distributing frames in common battery offices. The No. 1177A Protectors are furnished only in lengths of 101 Protectors per strip on $\frac{3}{8}$ inch centers. The No. 1177B Protectors are furnished only in lengths of 51 Protectors per strip on $\frac{3}{8}$ inch centers.

Code No.	Protector Mounting	Consists of Protector Blocks	Heat Coils
1177A	1 No. 77A	2 No. 28, 2 No. 29	2 No. 76A
1177B	1 No. 77B	2 No. 28, 2 No. 29	2 No. 76A

NO. 1268 AND NO. 1269 TYPE PROTECTORS

Each Protector provides for one pair of wires. The No. 1268 Type Protector terminals are so arranged that the line wires may be connected directly at one side of the Protector and jumpers, extending to a switchboard cable terminal block connected to the terminals on the other side of the mounting. These units are used on Type "B" main distributing frames.

The No. 1269 Type is similar to the No. 1268, except that the terminals are arranged for connecting the switchboard cable wires directly to one side, jumpers being used from the other side of the Protector to an outside line terminal block. These units are used on Type "A" main distributing frames.

The Nos. 1268 and 1269 Type Protectors may be mounted on walls or partitions by means of the No. 736A Mounting Plate. Where required, one or more of these mounting plates should be ordered as indicated under "Protector Mounting Plates."

Code No.	Furnished Only in Strips	Protector Mounting	Consists of Protector Blocks	Heat Coils
1268A	20 Protectors	1 No. 68A	2 No. 26, 2 No. 27	2 No. 76A
1268B	23 Protectors	1 No. 68B	2 No. 26, 2 No. 27	2 No. 76A
1269A	20 Protectors	1 No. 69A	2 No. 26, 2 No. 27	2 No. 76A

PROTECTORS—Continued**Large Carbon Block Protector**

The No. 86B (Large Carbon Block) Protector consists of a porcelain base having two-line terminals and one ground terminal, three large carbon blocks (which are so placed as to form a high voltage protector) and a metal cover. It is designed to protect telephone lines against high potential and abnormal currents.

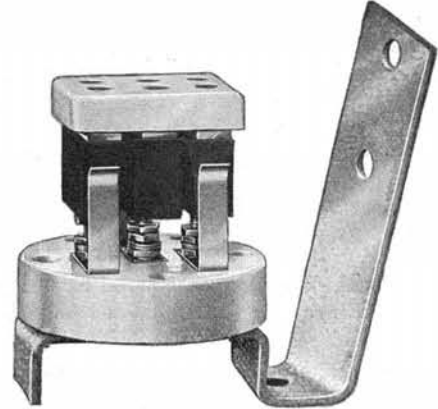
**No. 86B Protector, Cover Removed****Protector Blocks**

Code No.	Description	Used with Protector Micas
3	Plain carbon block with fuse metal	No. 1 and No. 6
4	Plain carbon block without fuse metal	No. 1 and No. 6

NO. 9 TYPE

The No. 9 Protector Block is a paraffined wood dummy which is used in place of the No. 1 and No. 2 Protector Blocks when the open-space cutout is to be made non-operative.

Code No.	Description
9	Paraffined wood dummy

NO. 15 TYPE

The No. 15 Protector Block is a paraffined wood dummy which is used in place of the Nos. 11 and 12.

Code No.	Description
15	Paraffined wood dummy

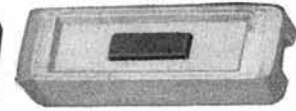
**No. 19****No. 20****No. 26****No. 27****NOS. 19, 20 AND 25 TYPES**

The Nos. 19 and 20 Protector Blocks are used together and form an open-space cutout suitable for protection against high potential due to lightning. A mica separator is placed between the blocks to secure the necessary air gap, the No. 10 Protector Mica usually being used for this purpose; when a higher breakdown voltage is desired the No. 11 Mica which is twice as thick may be used, thereby raising the voltage necessary to produce an arc across the air gap to approximately double the usual value. An open space cutout having a fusible metal plug in one side may be obtained by using the Nos. 20 and 25 Protector Blocks and a mica separator.

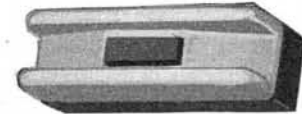
**Nos. 26 and 27
(Full Size)****No. 10
Protector Mica**

Code No.	Description	Used with Protectors
19	Plain copper block with two pins	60B and 80A
20	Grooved copper block with two bushings	60B and 80A
25	Plain copper block with two pins and fuse metal	Used in place of No. 19 Protector Block when fuse metal is desired.

NOS. 26 AND 27 TYPES

The Nos. 26 and 27 Protector Blocks are of new design and embody several advances in construction which greatly reduce maintenance costs and provide better telephone service through fewer interruptions of operation. They are used together without a separator (protector mica) and form an open space cutout which will afford the highest grade of protection against high potentials due to lightning. The two blocks differ in construction as follows:

The No. 26 Protector Block is a solid piece of hard non-dusting carbon. The face of the block is especially ground to present a smooth surface. The No. 26 Protector Block is mounted on the ground side of the protector mounting.

The No. 27 Protector Block consists of a porcelain frame with a countersunk hard carbon plug which is fastened in place with low temperature fusing cement. The surface of the frame which bears against the No. 26 Block, when assembled in a mounting, is finished by grinding. The air gap between the carbon insert in the No. 27 Block and the face of the No. 26 Block is held to close limits by this grinding process and the consistent operation of the cutouts at the proper voltage is thereby insured.

Ordinary lightning discharges will cause an arc across the air gap between the carbon blocks but will not heat them sufficiently to melt the cement used for holding the carbon plug in place. A cross with an

PROTECTOR BLOCKS—Continued

NOS. 26 AND 27 TYPES

electric light or power line, however, will cause a discharge or repeated discharges of such duration that the heating of the carbon insert of the No. 27 Blocks will melt the cement holding it in place and allow the mounting spring to push it into direct contact with the No. 26 Block, thus permanently grounding the line.

Code No.	Description	Used with Protectors
26	Carbon block	Nos. 12AP, 58AP, 60AP, 76AP, 1079AP, 1268A and 1269A. No. 83A Protector Mounting.
27	Porcelain frame with carbon insert	Same as No. 26, except No. 83A Protector Mounting.
28	Carbon block	For use with 29 Block.
29	Porcelain frame with carbon insert	Central Office protectors on 3/8 inch centers.
30	Porcelain frame with carbon insert	83A Protector Mounting.

The Nos. 26 and 27 Protector Blocks are interchangeable with the old combinations of Nos. 1 and 2 Protector Blocks and No. 3 Protector Mica both at subscribers' stations and central offices, and are therefore available for improving protective equipment already in service. This practice will result in fewer visits of the trouble man. All orders for replacements of Nos. 1 and 2 Protector Blocks and No. 3 Protector Micas should specify the Nos. 26 and 27 Protector Blocks; no separator (protector mica) is needed for the new design of block.

In addition to the above replacements, tests on cable protection have shown that Nos. 26 and 30 Protector Blocks require less attention and replacement due to grounded blocks than the Nos. 19 and 20 Blocks with the regulation .010-inch mica separators; therefore, the Nos. 26 and 30 Protector Blocks can be used advantageously wherever metal (Nos. 19 and 20) blocks are now used.

PROTECTOR MICAS

Code No.	Used with Protector Blocks	Used with Protectors
10	Nos. 19 and 20	Nos. 60B and 80A
*11	Nos. 19 and 20	No. 17B

* No. 11 Mica is twice as thick as the No. 10.

**PROTECTOR GROUPS
For Distributing Frames**

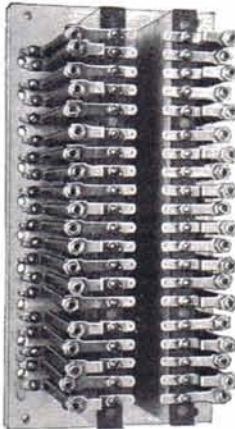

No. 1435U



No. 1269A Protector



No. 1435R & Y

These protector groups may be used for either central battery or magneto telephone lines and are intended to mount on various types of distributing frames and cabinets listed elsewhere in this catalog.

They consist of a mounting of proper size, for attaching to the frame, on which the protector apparatus as listed below is assembled:

Code No.	Protects	Consists of	Used with Distributing Frame No.
1435U	20 metallic outside lines against abnormal current.	20 protectors equipped with No. 7A Fuses and mounted on a base which serves as a fanning strip.	1420B 1430D, E, F 1431A
1435R	25 metallic outside lines where fuse protection is unnecessary.	A terminal strip mounted on a base which serves as a fanning strip.	
1435Y	20 metallic outside lines where fuse protection is unnecessary.	A terminal strip mounted on a base which serves as a fanning strip.	1420B 1430D, E, F 1431A
1435W	20 metallic inside lines against high potential and sneak currents.	20 No. 1269A Protectors mounted on a base which serves as a fanning strip.	
1435T	20 metallic inside lines against high potential and sneak currents.	20 No. 1269A Protectors.	1425C

PROTECTOR MOUNTINGS



No. 48B
Protector Mounting



No. 93A Protector Mounting



No. 83A Protector Mounting

Code No.	Description
16	Part of No. 58AP Protector, also used as part of mounting for No. 60A Fuse.
22B	A porcelain base equipped with clips and screws for holding a No. 24A Fuse. Part of the No. 62D Protector.
29B	For use in mounting protective apparatus of the Nos. 58, 74, 76 or 79 Type Protectors.
48B	An asbestos pad 8 x 4 $\frac{3}{8}$ inches for use with the No. 58 Type Protectors.
50C	A porcelain base equipped with clips and screws for holding a No. 35A Fuse. Part of the No. 62C Protector.
68A	For use in mounting protective apparatus of No. 1168 Type Protectors. Furnished only in one length, 20 per strip. Arranged to mount on "B" Type Distributing Frames and No. 736A Mounting Plates.
68B	Same as No. 68A except furnished in only one length, 23 per strip.
69A	For use in mounting protective apparatus of No. 1169 Type Protectors. Arranged to mount on "A" Type Distributing Frames and No. 736A Mounting Plates. Furnished only in one length, 20 per strip.
77A	For mounting protective apparatus of (101) No. 1077A or No. 1177A Protectors.
77B	For mounting protective apparatus of (51) No. 1177B Protectors.
78A	For mounting protective apparatus of No. 1078A Protectors.
83A	Designed to protect drop wires between the overhead lines and the subscriber's telephone set from lightning. This Protector Mounting consists of an iron box approximately 8 $\frac{3}{4}$ x 3 $\frac{1}{2}$ x 2 $\frac{1}{2}$ inches with a hinged cover having a No. 84A Protector Mounting within it. Arranged for pole mounting. Intended to be equipped with Nos. 26 and 30 Protector Blocks for cable protection for five pairs of wires. The box mounts directly underneath the crossarms on the poles. Two mounting lugs are provided for this purpose.
84B	Terminal block and springs for use as a replacement part in the No. 84A Protector Mounting. Furnished with mounting screws and washers.
86A	Galvanized metal box approximately 10 x 5 $\frac{3}{16}$ x 3 $\frac{1}{4}$ inches overall having a sliding cover with a locking screw. For housing No. 58 Type Protectors in outside installations. Replaces the No. 82A.
87A	Consists of a metal mounting strip equipped with metal mounting brackets and wooden fanning strips. Will mount six No. 84A Protector Mountings. Intended for use in EA26 and EU26 Cable Terminals. Furnished with screws for mounting the Protector Mountings and also for mounting the assembly in the Cable Terminal.
93A	Consists of a galvanized metal box having a slip cover with locking screws and two screws for mounting the Protector in the box. The cover includes a shield of insulating material which protects the line terminals from gases expelled during fuse operation. Intended for use in housing the No. 98A Protector in outdoor installations. When equipped with a No. 98A Protector entirely replaces the No. 1086A Protector. Overall dimensions 7 $\frac{3}{4}$ x 5 $\frac{7}{8}$ x 2 $\frac{3}{16}$ inches.

PROTECTOR MOUNTINGS—Continued

Mounting Plate for Protectors

The No. 736A Mounting Plate is used with the Nos. 1268 and 1269 Type Protectors when they are to be mounted on flat surfaces such as walls and partitions. It consists of a supporting bar $\frac{1}{4} \times 1\frac{1}{2}$ inches equipped with angle brackets adapted to fasten to cross strips on the wall, etc., and can be supplied in lengths suitable for use with protectors for from 20 to 243 lines. These mounting plates progress in capacity arranged for 20 or 23 and 40 or 43, etc., protectors each. When ordering, give the code number for the mounting plate and the number of protectors to be mounted per plate.

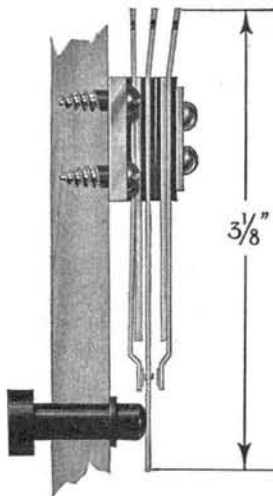

No. 1006A Push Button

Push Buttons

These push buttons are suitable for general telephone use, but are primarily intended for use in magneto telephones for "central office selective signalling" service. Other uses will be suggested by the descriptive matter in this catalog under "Definition of Terms."

The springs are of nickel silver and are backed up with brass stop springs. The ends of the springs are notched and tinned in order to permit wires being readily soldered to them. The button is made of hard rubber.

Note. The No. 465 Type Keys consist of push buttons mounted in small wooden boxes suitable for use in connection with telephone apparatus.

Code No.	Spring Combination	Buttons Furnished for Woodwork Thickness	Principal Use
1002A	Five springs arranged for one break two make contacts.	$\frac{13}{32}$, $\frac{1}{2}$ or $\frac{9}{16}$ inch as specified.	Used in magneto telephones for central office signalling.
1004A	Six springs arranged for two break-make contacts.*	$\frac{1}{2}$ in.	Used in magneto telephones for "signalling central secretly."
1006A	Three springs arranged for one break-make contact.	$\frac{13}{32}$, $\frac{1}{2}$ or $\frac{9}{16}$ inch as specified.**	Used in magneto telephones for "central office signalling."

* The No. 1004A is in effect two No. 1006A Push Buttons.

** A button for $\frac{13}{32}$ inch wood will be furnished in cases when orders do not specify the thickness of the woodwork with which the push button is desired for use.

RECEIVERS**Central Battery and Local Battery Service**

FOR WALL TELEPHONES AND DESK STANDS

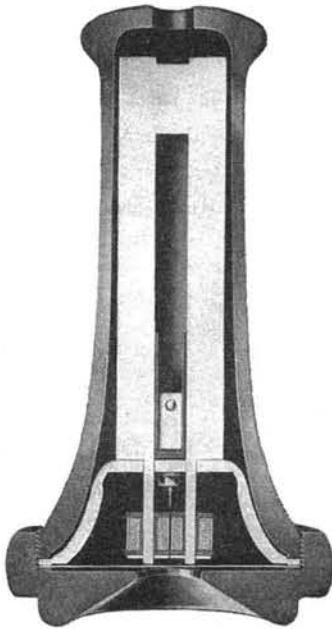

Cross Section, No. 144 Receiver



No. 144 and No. 171 Receiver



No. 146A Receiver

THE NO. 144 RECEIVER is intended for use on telephones and desk stands for standard central battery and local battery service. This Receiver weighs thirteen ounces and will operate any of our Nos. 140 and 143 Type Switch Hooks and the Switch Hooks of our standard desk stands. Equipped with binding posts that will take either pin (No. 29 Type) or flat (No. 62 Type) Cord Tips.

THE NO. 146A WATCH CASE TYPE RECEIVER is intended principally for use in multiple with the regular Receiver furnished on a desk stand or telephone. Equipped with a cut-in switch. Will fit the No. 1A Receiver Holder which is designed for use on desk stands. It is principally used on telephones installed in noisy locations or where the telephone user has defective hearing.

THE NO. 171 RECEIVER is a bi-polar Receiver not provided with a permanent magnet. This Receiver in view of its light weight ($5\frac{1}{2}$ ounces) is suitable only for use with the No. 143M Switch Hook and No. 1020AH Desk Stand. Equipped with binding posts that will take either pin (No. 29 Type) or flat (No. 62 Type) Cord Tips.

THE NO. 558 RECEIVER is similar to the No. 144 except that it is provided with a special cord bushing which secures the cord and prevents it from turning, greatly reducing the breaking of the conductors at that point.

THE NO. 567A RECEIVER is a high efficiency Receiver with permalloy diaphragm and cores.

Code No.	Resistance Ohms	Approximate Impedance	Use	Replaces
144	33	215 Ohms at 800 cycles	Standard desk stands and telephone sets.	144AW
146A	640	2000 Ohms at 800 cycles	In multiple with the regular hand Receiver on desk stands in connection with the No. 1A Receiver Holder.	146AW
*171	41		In series central battery service.	
558	84	215 Ohms at 800 cycles	With 1536E Telephone Set in mines where explosive gases are present. One R2AD Cord is furnished as a part of this Receiver.	558W
567A	...	240 Ohms at 800 cycles (damped)	With 634BB Subscriber Set.	

* Repair parts for No. 171 Outer Shell, Cap and Diaphragm: Outer Shell P-92613, Cap P-91614, Diaphragm P-95114.

RECEIVERS—Continued

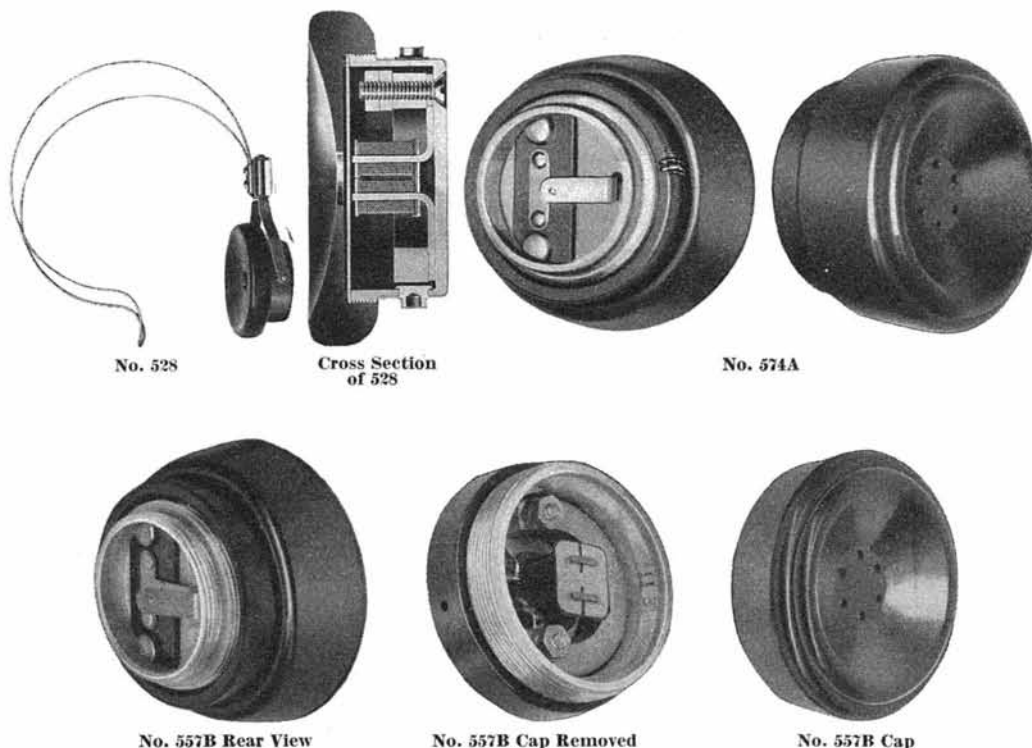

FOR HAND SETS, TELEPHONE SETS AND TEST SETS

Code No.	Resistance Ohms	Approximate Impedance	Finish	Used With
131	71	{ 240 Ohms } { at 800 cycles }	Black	{ No. 1001 Type Hand Sets. Replaces } { No. 131W and 131BW }
141	70	—	Nickel plated	{ No. 1002 Type Hand Sets. Replaces } { No. 141W. }
515	45	—	Black	{ No. 1017 Type Test Sets. Replaces } { No. 515W. }
528	56	{ 260 ohms } { at 800 cycles }	Black	{ Operators' telephone sets. Cords hav- } { ing No. 80 Cord Tips at Receiver } { end. Furnished with head band. } { Replaces No. 528BW. }
557B-3	30	{ 130 ohms } { at 800 cycles }	*Black	E1B and E2A Hand Sets.
**562A	60		Black	{ No. 1526B Portable Telephone Set. } { Also on telephone lines paralleling } { high tension transmission lines. }
574A-3	—	{ 245 ohms } { at 800 cycles } { (damped) }	*Black	E2B Hand Set.

* Also available in ivory, gray, old brass, statuary bronze, oxidized silver, medium gold and dark gold.

** Repair parts for No. 562A Outer Shell, Cap and Diaphragm: Outer Shell P-220285, Cap P-220278, Diaphragm P-98387.

Receivers—Continued

REPLACEMENT PARTS

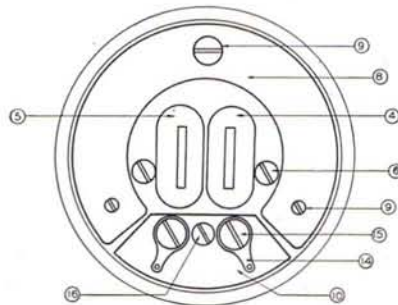
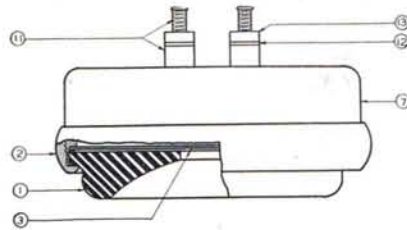

Fig. 1

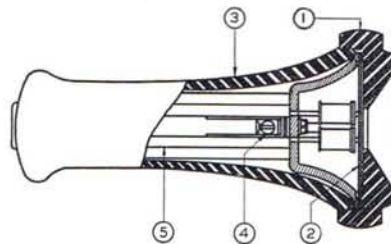

Fig. 2

Symbol	Name of Piece Part	Receiver Code Nos.	Symbol	Name of Piece Part	Receiver Code Nos.
		131			131
		(See Fig. 1)		Receiver Block (Continued)	(See Fig. 1)
1	Cap.....	P-81496	14	Terminal Lugs.....	P-81500
2	Ring Nut.....	P-98439	15	Terminal Lug Machine Screws	P-82027
3	Diaphragm.....	P-81525	16	Round Head Machine Screw	P-82029
4	Right Coil.....	P-95265			144
5	Left Coil.....	P-95276			(See Fig. 2)
6	Core Screws.....	P-98336	1	Receiver Cap.....	P-98948
7	Case.....	P-98956	2	Diaphragm.....	P-95114
8	Magnets.....	P-81488 (2)	3	Case.....	P-220224
		P-81489 (1)	4	Machine Screw.....	P-93799
9	Magnet Machine Screws.....	P-68568 (2)	5	Inner Unit.....	P-94436
		P-82028 (1)			567A
	Receiver Block.....	P-81499			(See Fig. 2)
10	Binding Post Block.....	P-81498	1	Receiver Cap.....	P-222159
11	Binding Post.....	P-81497	2	Diaphragm.....	P-229505
12	Washers.....	P-132152	3	Case.....	P-229508
13	Nuts.....	P-82275	4	Machine Screw.....	
			5	Inner Unit.....	P-229510

RECEIVERS
Replacement Parts
(Continued)

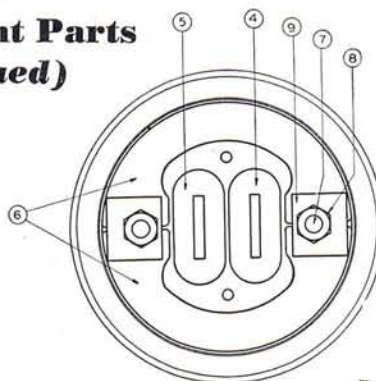
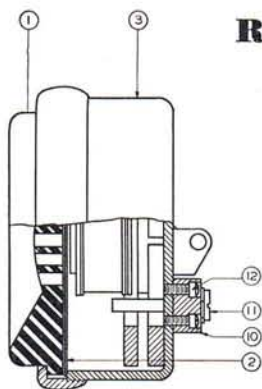

Fig. 3

Receiver Code
No. 141
(See Fig. 3)

Symbol	Name of Piece Part	Receiver Code
1	Receiver Cap.....	P-88295
2	Diaphragm.....	P-95114
3	Case.....	P-220340
4	Right Coil.....	P-80972
5	Left Coil.....	P-80724
6	Magnets.....	P-87383
7	Magnet Machine Screws.....	P-88287
8	Magnet Machine Screw Nuts.....	P-87115
9	Magnet Clamp.....	P-87410
	Receiver Block Assembly	
10	Binding Post Block.....	P-88291
11	Binding Post Screw.....	P-88285
12	Round Head Machine Screws.....	P-88286
13	Terminal Cap.....

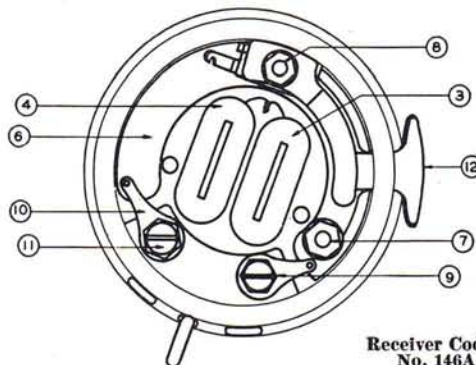
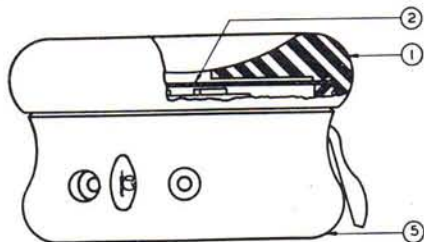

Fig. 4

Receiver Code
No. 146A
(See Fig. 4)

Symbol	Name of Piece Part	Receiver Code
1	Receiver Cap.....	P-94545
2	Diaphragm.....	P-95225
3	Right Coil.....	P-90692
4	Left Coil.....	P-90693
5	Case.....	P-99373
6	Magnets.....	P-95254 (2)
		P-95255
7	Magnet Machine Screw.....	P-99354
	Washer.....	P-91042
	Nuts.....	P-99355
8	Magnet Machine Screw.....	P-99353
	Washers.....	*P-103705
	Nuts.....	†P-137521
	Receiver Block Assembly	P-92609
9	Binding Post (Nut).....	P-95788
10	Terminal Lugs.....	P-97285
11	Terminal Lug Machine Screws.....	P-82324
12	Switch Lever.....	P-99351

* Brass.

† Phenol Fibre.

RECEIVERS

Replacement Parts—Continued

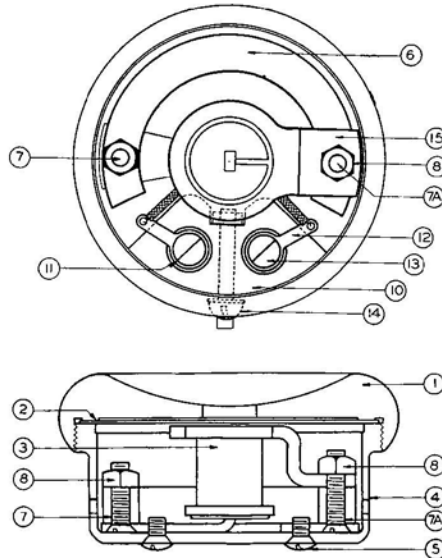

Fig. 5

Sym- bol	Name of Piece Part	Receiver Code Nos.	
		515 (See Fig. 5)	528 (See Fig. 5)
1	Receiver Cap.....	P-94545	P-213314
2	Diaphragm.....	P-95225	P-98387
3	{ Right Coil..... Left Coil..... }	P-207461	P-230412 P-230411
4	Case.....	P-215905	P-98949
5	Case Screws.....	P-97053
6	Magnet.....	P-97064	P-99862
7	Magnet Machine Screws.....	P-97055	P-99541
7A	Magnet Machine Screws.....	P-97056	P-99541
8	Magnet Machine Screw Nuts.....	P-132958	P-98752
9	Receiver Block Assembly.....	P-132958
10	Binding Post Block.....	P-98974	P-233887
11	Binding Posts.....	P-98358
12	Terminal Lugs.....	P-97062	P-229679
13	Terminal Lug Machine Screws.....	P-93540	P-99794
14	Round Head Machine Screw.....	P-98975	P-99540
	Nut.....	P-92609	P-99100
		*P-99101
15	Ring Pole Piece.....	P-97066
	* Locking Nut.		

RECEIVERS

Replacement Parts—Continued

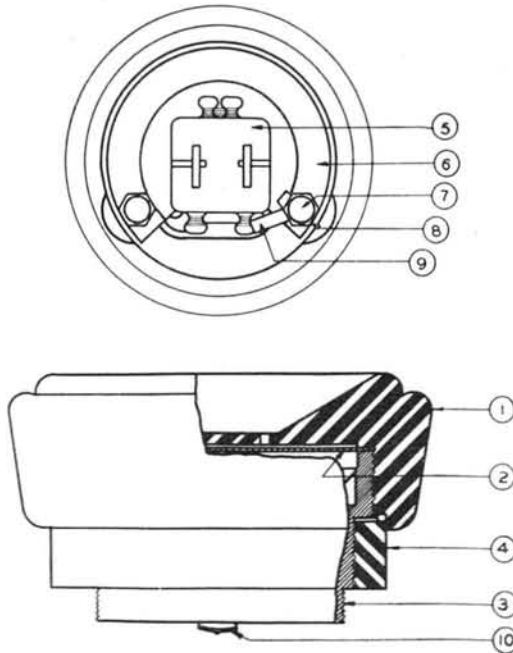

Fig. 6

Sym- bol	Name of Piece Part	Receiver Code Nos. 557B-3 and 574A-3 (See Fig. 6)
1	Cap.....	* P-235970
2	Diaphragm.....	P-98387
3	Case.....	P-225809
4	Lock Ring.....	P-208591
	Coil Assembly.....	** P-225096
5	Right Coil.....	P-208678
	Left Coil.....	P-208679
6	Magnet.....	P-208692
7	Magnet Machine Screws.....	P-225807
8	Magnet Machine Screw Nuts.....	P-98752
9	Terminal Lug.....	P-225810
10	Contact Spring.....	P-225805

* P-235971 for the 574A-3
** P-225097 for the 574A-3

Receiver Holder

NO. 1 TYPE

- 1A This is designed for use on No. 1040 Type Desk Stands for holding a No. 146AW Receiver, in cases where this receiver is connected in multiple with the regular desk stand receiver. It is designed so that the receiver may be easily removed but is normally held so firmly that it will not be dislodged accidentally or rattle. This receiver holder is so arranged that it can be mounted by means of the screw which holds the transmitter in place. It has a black finish.

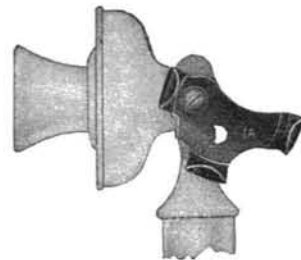

No. 1A Receiver Holder

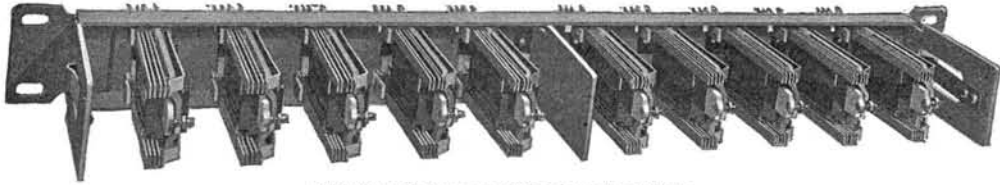
RELAYS

"E" Type Relays on 737B Mounting Plate

Relay Types

The relay is an essential and important piece of telephone equipment and the correct design of this class of apparatus, not only materially affects the quality of service rendered by the entire telephone plant, but also the expense incurred in securing that service. The increasing use of central battery equipments necessitate relays suitable for operation on direct, pulsating, and alternating current in circuits not only calling for a wide variety of spring arrangements and combinations, but also for slow acting as well as fast acting types. Relays of high impedance and those of low impedance have very definite fields of application and polarized relays are necessary for accomplishing certain results. To meet these varying conditions, the Western Electric Company has developed a number of relay types; each type being supplied with the character of windings and arrangement of contacts to meet the requirements of the circuits in which it is to be placed. It is impracticable to catalog them all here, the main types only being described. Further details will be supplied upon request.

Flat Type Relays

The expense of installation, operation and maintenance are reduced to a minimum by the use of standardized forms of apparatus. After careful analysis of the circuit conditions under which relays are most commonly used, the "Flat Type Relay" form of construction has been evolved which lends itself readily to a great variety of slight changes through winding modifications and contact arrangements, producing a relay ideally suited to a multiplicity of applications and requirements. The advantages of Flat Type Relays are briefly indicated below.

1. **Efficiency of Operation.** Each relay requires the minimum amount of current consistent with the conditions under which it operates. These conditions cover the contact pressures necessary both during operation and in its non-operative position, the speed or time of operation and the requirements as to high or low impedance which its position in the circuit makes necessary. High efficiency is attained through a careful choice of materials and the correct proportioning of the parts.
2. **Permanent and Easy Adjustments.** All Flat Type Relays have their spring contacts and armature air gaps at the front end of the relay where they are clearly visible while being adjusted when in place on their mountings. The adjustments are permanent over long periods of service, being maintained under widely varied conditions of heat, cold and humidity.
3. **Insulation of Contact Springs.** "Phenol Fibre" is used for spring insulation. This material in addition to having the high dielectric strength of hard rubber has the advantage of not being affected by heat, moisture or deterioration like rubber.
4. **Self Cleaning Contacts.** All contacts are so mounted that their surfaces are in a vertical plane, allowing dust to fall out of, rather than settle on, the contacts. Maintenance is reduced by this construction and difficulties due to poor contacts avoided.
5. **Armature Suspension.** A flat, reed type spring is used for armature suspension in all Flat Type Relays. This feature of design secures a continuous and unvarying magnetic path between the armature and the core. By the selection of suitable springs, extremely sensitive relays are obtained with this type of construction.
6. **Durability of Parts.** All steel parts are galvanized. The special alloy steels used are not only the best material, electrically, for the parts in which they are utilized, but are mechanically strong materials from which small parts having great strength may be made. The spoolheads are of Phenol Fibre and the windings are highly insulated. All windings will carry continuously without injury currents greater than required for operation.
7. **Small Size and Ease of Mountings.** Compact in design, these relays are light in weight and occupy a small amount of space. Their terminals are all at one end and conveniently arranged for making soldered connections. Mounting plates for placing groups of relays under common dust-proof covers and also mounting plates for use when individual cross-talk proof covers are required on each relay are listed elsewhere, as all flat type relays are insulated from their mountings and are fastened in place by means of two screws; their stability and ruggedness when mounted reduces maintenance costs.

RELAYS

Flat Type Relays—Continued

The "A," "B," "E," "H," and "G" Type Relays are all of the Flat Type form of construction and can be supplied to meet a great variety of circuit conditions.

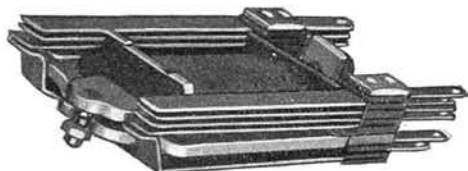

"A," "E," & "H" Type Relay

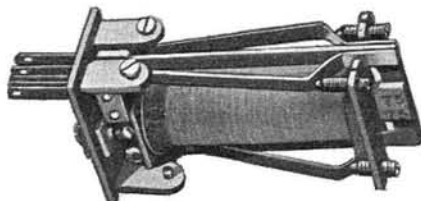

"B" & "G" Type Relay with Cover Removed

"A" TYPE RELAYS

The "A" Type Relays are designed for use as line and cut-off relays only. These relays will mount on 3/4 and 7/8 inch horizontal and 1 3/4 vertical centers. Intended to mount on mounting plates provided with dust-proof metal covers.

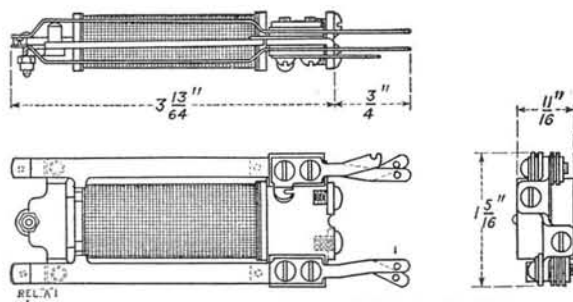

NOS. A2 & A43 ALSO GENERAL DESIGN AND DIMENSIONS OF "A" TYPE

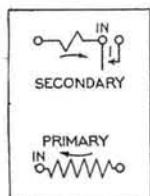

FIG. 1
A-1

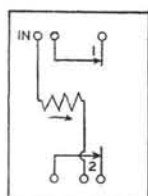

FIG. 2
A-2

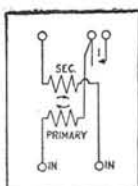

FIG. 31
A-25

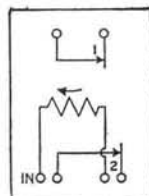

FIG. 27
A-26

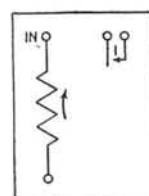

FIG. 5
A-50

Schematics Showing Windings

Code No.	Windings	Rated Resistance (Ohms)	Operate (Ampere)	Release (Ampere)	Non-Operate (Ampere)
A-1	{ Primary Secondary	{ 1000 1000	.0058	.0024
A-2	Single	34	.060
A-25	{ Primary Secondary	{ 1000 1000	.0058	.0024
A-26	Single	34	.047
A-50	Single	34	.040	.020

RELAYS

Flat Type Relays—Continued

“E” TYPE RELAYS

The “E” Type Relays are designed for heavy duty, all-around purpose telephone relays. The relays are designed for two sets of contact springs which may be duplicates or may differ in contact arrangement, making it possible, in many cases, to use one of these relays where two or more of another style would be required. May be mounted in groups on punched type mounting plates (see listings elsewhere) which are provided with common dust-proof metal covers on 1 3/4 inch vertical and 3/4 inch or 1 inch horizontal centers (depending upon the number of contact springs). When an individual dust-proof cover for each relay is desired the E1 Relay Cover should be specified. In this case the relay will mount on 1 1/4 inch horizontal centers and 1 3/4 inch vertical centers.

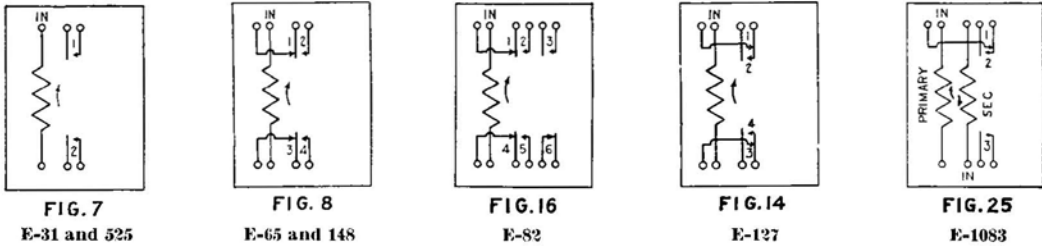
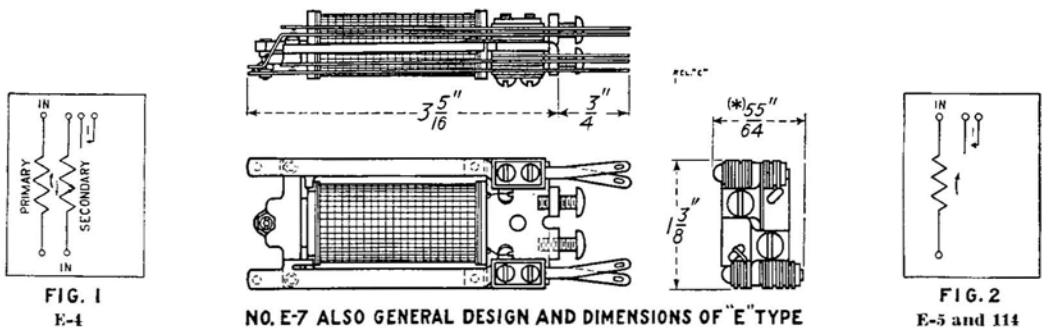

Schematics

Code No.	Windings	Rated Resistance (Ohms)	Operate (Ampere)	Release (Ampere)	Non-Operate (Ampere)
E-4	Primary	250	.0131
	Secondary	700	.008006
E-5	Single	1000	.008	.003
E-31	Single	500	.012
E-65	Single	1000	.013
E-82	Single	34	.070
E-114	Single	500	.0099	.0032
E-127	Single	500	.018
E-148	Single	350	.018
E-216	Single	500	.022
E-370	Single	500	.018
E-525	Single	220	.020
E-1083	Primary	650	.016
	Secondary	1000	.028

RELAYS

Flat Type Relays—Continued

“H” TYPE RELAYS

The relays of the “H” Type are similar to the “E” Relays, except that they have a higher impedance at talking frequencies due to the laminated construction of their cores. They are each equipped with a cross-talk proof cover and will mount on 1¼ inch horizontal and 1¾ inch vertical centers.

“B” TYPE RELAYS

“B” Type Relays differ from the above “A,” “E,” and “H” Types in that they are provided with a micrometer screw adjustment feature which permits of extremely accurate adjustments being made. They are used as supervising relays in switchboard cord circuits and in other places where a sensitive, highly efficient and reliable relay is required. When used as a series supervisory relay, the transmission loss is very low. These relays have superior “flashing” ability and will operate in a line having as high as 1,000 ohms resistance.

“B” Type Relays are provided with individual covers, each having a removable cap which may be placed in position without affecting the adjustment of the relay. The individual covers are dust-proof and cross-talk proof on all “B” Type Supervisory Relays. For purposes in which the cross-talk shielding is not required, dust-proof covers are supplied. These relays may be mounted on 1¼ inch horizontal and 1¾ inch vertical centers.

The use of a supervisory relay of the “B” Type secures the operating advantages which are obtained through sensitive adjustment and small operating current low transmission loss, and reduced maintenance.

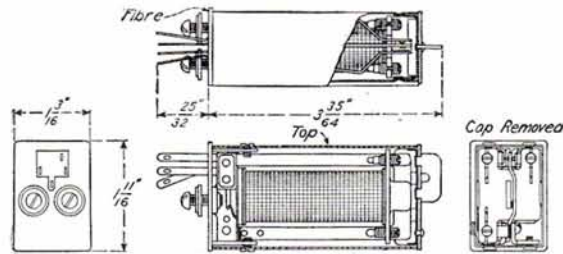

B) ALSO GENERAL DESIGN & DIMENSIONS OF 'B' TYPE

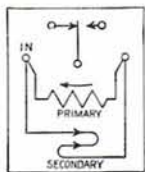

FIG. 3
B-3

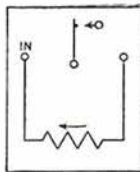

FIG. 5
B-10

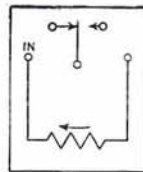

FIG. 6
B-22&46

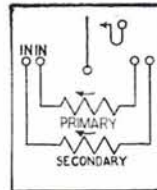

FIG. 30.
B-105

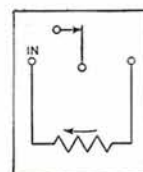

FIG. 4
B-223

Schematics

Code No.	Windings	Rated Resistance (Ohms)	Operate (Ampere)	Release (Ampere)
B-3	{ Primary Secondary Combined	{ 16.4 31 10.7	.015	.005
B-10	Single	1.7	.022	.002
B-22	Single	96	.016
B-46	Single	220	.0023	.0009
B-105	{ Primary Secondary	{ 27 5000	{ .013 .0015	{0005
B-223	Single	1000	.006	.0035

RELAYS

Flat Type Relays—Continued

“G” TYPE RELAYS

The relays of the “G” Type are similar to the “B” Type relays except that they have a higher impedance at talking frequencies due to the laminated construction of their cores. Each relay is equipped with a cross-talk proof shell with removable cap and will mount on 1¼ inch horizontal and 1¾ inch vertical centers.

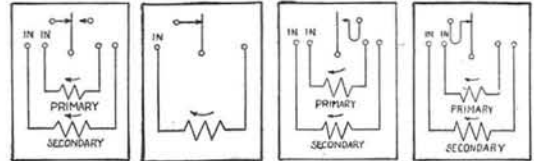
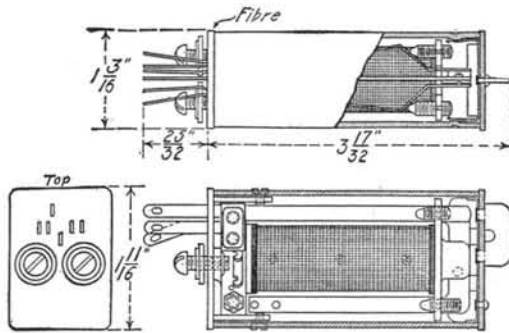

FIG. 7 G-1
FIG. 1 G-28 and 32
FIG. 14 G-29
FIG. 15 G-41

SCHEMATICS

NO. G-3 ALSO GENERAL DESIGN AND DIMENSIONS OF “G” TYPE

Code No.	Windings	Rated Resistance (Ohms)	Operate (Ampere)	Release (Ampere)
G-1	{ Primary Secondary	{ 75 75 }	.010	.005
G-28	Single	365	.0037	.001
G-29	{ Primary Secondary	{ 500 3500 }	.0022 .0025	.0003
G-32	Single	900	.003	.0008
G-41	{ Primary Secondary	{ 250 250 }	.0104	.0066

“J” TYPE RELAYS

“J” Type Relays are designed for use with alternating current and are otherwise similar to the “B” Type Relays but having different core, spoolhead and adjusting plate characteristics. Each relay is equipped with a metal dustproof cover with removable cap and will mount on 1¼ inch horizontal and 1¾ inch vertical centers.

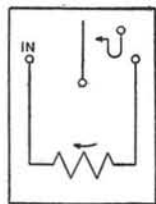

FIG. 3
J-3 and 20

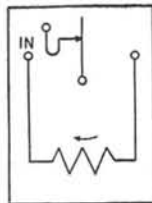

FIG. 6
J-15

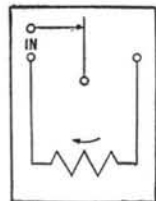
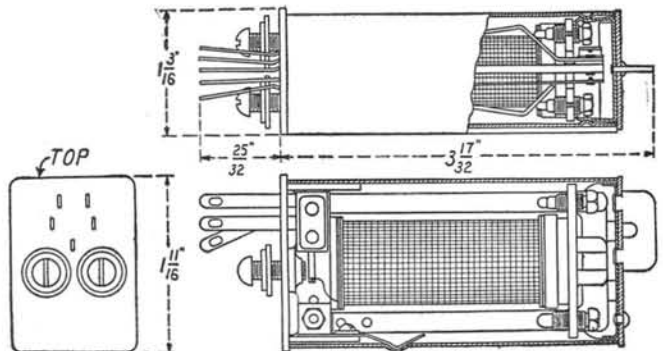

FIG. 7
J-11



NO. J-1 ALSO GENERAL DESIGN AND DIMENSIONS OF “J” TYPE

RELAYS

Flat Type Relays

“J” TYPE RELAYS—(Continued)

Code No.	Windings	Rated Resistance (Ohms)	A.C. Volts	Operate Amperes	A.C. Volts	Non-Operate Amperes
J-3	Single	1090	—	.006	—	—
J-11	Single	1090	—	.006	—	—
J-15	Single	1600	—	.004	—	—
J-20	Single	1600	—	.004	—	—

“R” TYPE RELAYS

The “R” Type Relays are similar to the “E” Type except that the core, although having the same cross-sectional area, is of a semi-elliptical shape which affords a greater winding space and permits of a shorter length of turn than is possible on the “E” Type Core. Insulated from the mounting plate.

These relays mount on drilled type mounting plates on 1 3/4 inch vertical centers and 1 inch horizontal centers unless provided with individual dust-proof covers, in which case they mount on 1 1/4 inch horizontal centers. Will also mount on punched type mounting plates, except where the horizontal mounting centers of the relay exceed 1 inch.

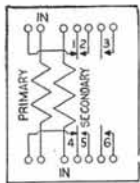

FIG. 36
R-49

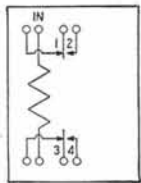
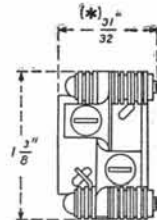
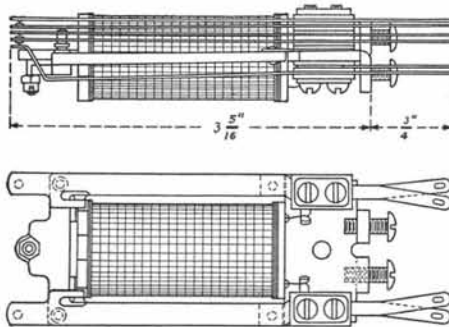

FIG. 48
R-286



NO. R-7 ALSO GENERAL DESIGN AND DIMENSIONS OF “R” TYPE

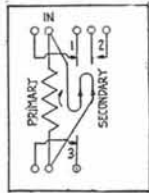

FIG. 215
R-503

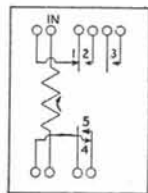

FIG. 94
R-852

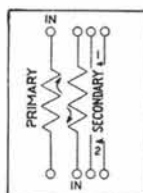

FIG. 89
R-913

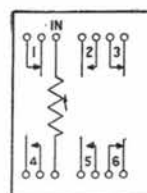

FIG. 151
R-966

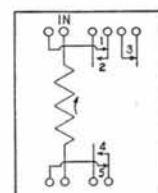

FIG. 307
R-1333

Schematics

Code No.	Windings	Rated Resistance (Ohms)	Operate (Ampere)	Release (Ampere)	Non-Operate (Ampere)
R-49	{ Primary	225	.055
R-286	{ Secondary	275	.056
	Single	275	.019
R-503	{ Primary	2100	.0175
	{ Secondary N.I.	2800			
	{ Combined	1200			
R-851	Single	365	.028017
R-852	Single	1200	.0107
R-913	{ Primary	550	.0185010
	{ Secondary	550	.0415020
R-966	Single	155	.057021
R-1333	Single	50	.064

RELAYS—Continued

NO. 85 TYPE RELAYS

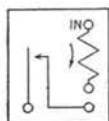

Schematic, Nos. 85M, N & P Relays

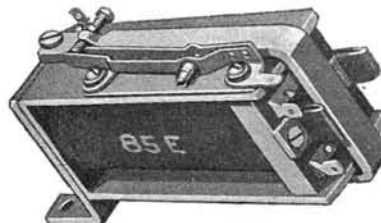

No. 85 Type Relay

The No. 85 Type Relays are slow acting and operate on either alternating or direct current. They are used in subscriber sets as indicated below. Mount singly in a vertical position.

Code No.	Rated Resistance (Ohms)	Operates through Resistance (Ohms)	Used
85M	2040	**18000	In four-party selective subscriber sets. In four-party selective subscriber sets. In 634FR and 653FR subscriber sets.
85N	2040	* 5000	
85P	5700	* 5000	

Note. * Non-inductive, in series with a 1/2 mf condenser on 60 volts A.C., 16 2/3 cycles and non-operate through 8,000 non-inductive resistance in series with a 1/2 mf condenser on 60 volts A.C., 16 2/3 cycles.

** Non-inductive, on 90 volts A.C., 16 2/3 cycles.

NO. 114 TYPE RELAYS

Relays of the No. 114 Type operate on direct current and have one or two operating windings. They are provided with cross-talk proof shells. One contact is made and one broken when the relay is operated.

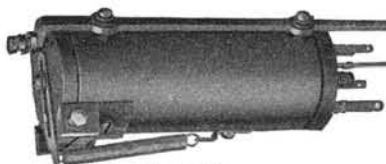

No. 114 Type

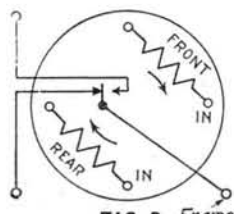

FIG. 2
No. 114B

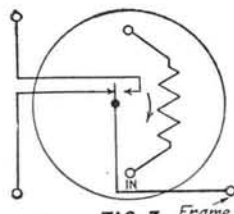

FIG. 3
No. 114G
No. 114AU

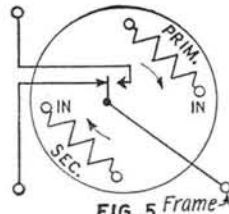

FIG. 5
No. 114K

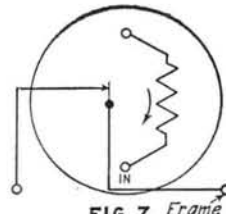

FIG. 7
No. 114AK

Code No.	Windings	Rated Resistance (Ohms)	Operate (Ampere)	Non-Operate (Ampere)
114B	{ Front Rear	{ 97 97	*.010	*.009
114G	Single	520	.006	.0055
114K	{ Primary Secondary	{ 72 33	.016 **	.0145
(a) 114AK	Single	188	(b)	(c)
114AU	Single	520	.029	.026

Notes. * Through both windings in series aiding.

** Holds on .034 ampere.

(a) Intended for use as tripping relay in machine ringing circuits.

(b) Operates on 100 volts A.C. at 19 1/6 cycles superimposed on 18 volts D.C. Operates in series with 940 ohm non-inductive resistance.

(c) Non-operates in series with 1130 ohms non-inductive resistance.

RELAYS—Continued

NO. 149 AND NO. 178 TYPE RELAYS

The No. 149 Type Relays are slow-release cut-off relays. Equipped with dust-proof metal covers and will mount on $1\frac{23}{32}$ inch centers.

The No. 178 Type Relays are similar in design to the No. 149 Types and in addition are designed for slow operation. Will mount on $1\frac{23}{32}$ inch centers.

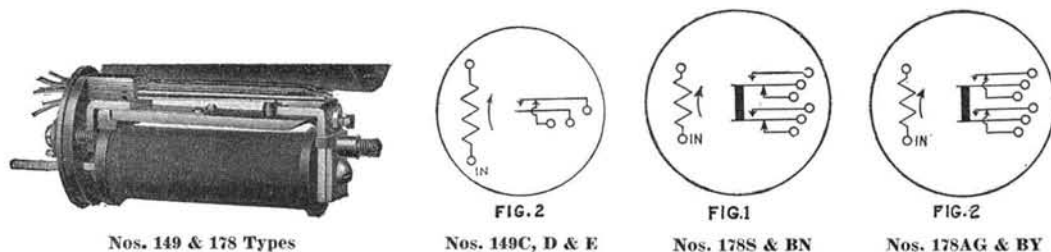

Code No.	Windings	Rated Resistance (Ohms)	Operate (Amperes)	Non-Operate (Ampere)	Release (Ampere)
149C	Single	99	.017005
149D	Single	485	.010003
149E	Single	9.5	.100	.060
178S	Single	320	.056	.048
178AG	Single	320	.030002
178BN	Single	1050	.030	.020
178BY	Single	2000	.00750006

NO. 196 TYPE RELAYS

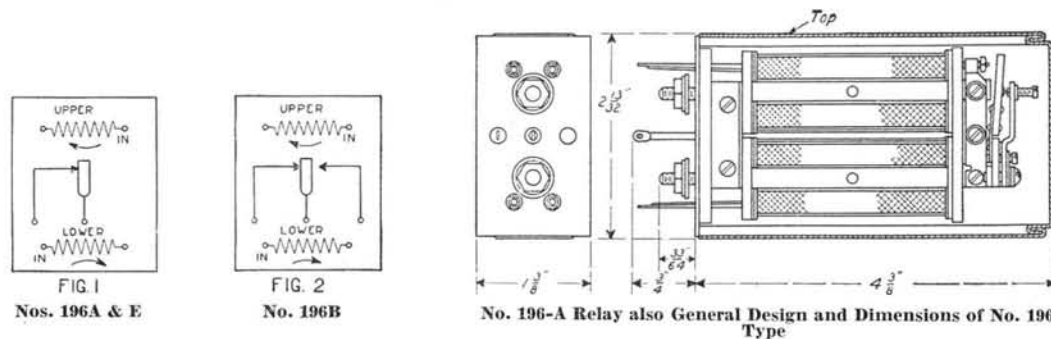

The No. 196 Type Relays are return pole piece Relays and are equipped with dust-proof covers. They have a rectangular laminated "U" shaped core provided with two form wound coils. Will mount on $2\frac{7}{16}$ inch vertical and $1\frac{1}{16}$ inch horizontal centers.

Code No.	Windings	Rated Resistance (Ohms)	Operate (Ampere)	Release (Ampere)
196A	Upper	1600	*.001	Open circuit
	Lower	1600		
196B	Upper	1600	*.001	Open circuit
	Lower	1600		
196E	Upper	240	*.0023	Open circuit
	Lower	240		

Note. * Through both windings in series

RELAYS—Continued**NO. 215 TYPE**

The No. 215 Type Relays are polarized relays equipped with reed type armatures and dust-proof covers. They mount on No. 823 or similar type Mounting Plates through the medium of No. 18B Connecting Blocks. They are insulated from the mounting plates and will mount mechanically on $2\frac{3}{4}$ -inch vertical and horizontal centers but due to their sensitiveness to magnetic interference the mounting centers with respect to other relays or any other magnetic apparatus should be given special consideration in each case.

Code No.	Windings	Resistance (Ohms)	Operating Ampere
215A	Parallel	85 each	(*)
215FA	Single	595	†

Note:

* For reliable operation in telegraph circuits, should receive an operating current of not less than .015 amp. through both windings in series aiding, but the relay is adjusted to operate at a speed not greater than 60 times per minute on current reversals of .002 amp.

† For reliable operation for general use, should receive an operating current of not less than .00083 ampere, but the relay is adjusted to operate at a speed of approximately 60 times per minute on current reversals of .0005 ampere.

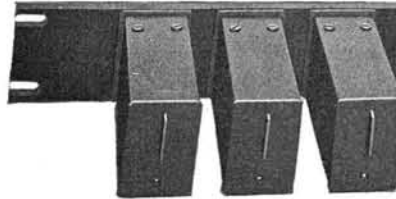
Relay Covers**Relay Covers (on Mounting Plate)****E1 RELAY COVER**

The E1 Relay Cover is an individual dust cover for "E" Type Relays when used on mounting plates without the regular mounting plate cover. Has a black finish and is furnished with a support which attaches to the relay and holds the cover in place. The minimum centers on which the "E" Type Relays will mount when equipped with these covers are $1\frac{1}{4}$ inches horizontal and $1\frac{3}{4}$ inches vertical.

E2 RELAY COVER

The E2 Relay Cover has a removable cap, which when removed gives access to the contacts for examination, otherwise same as E1 Relay Cover.

R1 RELAY COVER

The R1 Relay Cover is an individual dust-proof cover for "R" Type Relays when used on mounting plates without the regular mounting plate cover. Has a black finish and is furnished with a support which attaches to the relay and holds the cover in place. The minimum centers on which "R" Type Relays will mount when equipped with these covers are $1\frac{1}{4}$ inch horizontal and $1\frac{3}{4}$ inch vertical.

R2 RELAY COVER

The R2 Relay Cover is similar to the R1.

The "R" Type Relays will mount on $1\frac{3}{8}$ inch horizontal, and $1\frac{3}{4}$ inch vertical centers when equipped with these covers.

REPEATING COILS



No. 20A

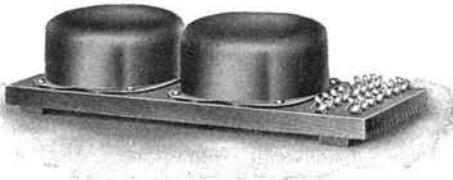

No. 25A



No. 26A

NO. 20 TYPE

The No. 20 Type Coils are intended for use in operator's telephone set for busy test. The No. 20E is for use at positions equipped with machine ringing trunks provided with mechanical locking keys. The No. 20G and H are for use in "B" operators' anti-side tone set.

Code No.	No. of Coils	No. of Windings Each Coil	Winding Resistances, Ohms			Impedance Ratio	Dimensions, Inches	
			Primary	Secondary	Tertiary		Wood Base	Coil
20A	1	2	277	40	360	1 to 45	5 ⁷ / ₁₆ x 1 ¹ / ₄
20E	1	2	215	29	365	3 ¹ / ₄ x 1 ⁵ / ₃₂
20G	1	2	277	40	3 ¹ / ₄ x 1 ⁵ / ₃₂
20H	1	2	215	29	3 ¹ / ₄ x 1 ⁵ / ₃₂

NOS. 25 AND 26 TYPES

The following Coils are intended for use in the regular cord circuits and incoming trunk circuits of central battery switchboards.

The No. 25A has terminals for both Coils at one end of wood base.

The No. 26A is equivalent to one-half of No. 25A.

Code No.	No. of Coils	No. of Windings Each Coil	Winding Resistances Ohms		Impedance Ratio	Dimensions, Inches Wood Base
			Primary	Secondary		
25A	2	4	2 of 21	2 of 21	1 to 1	10 ³ / ₄ x 4
26A	1	4	2 of 21	2 of 21	1 to 1	10 ³ / ₄ x 4



No. 49A Repeating Coil

NO. 49A TYPE

The No. 49A Coil is intended for use in graduated howler circuit of the No. 12 Local Test Desk and trouble positions of local switchboards. Taps are brought out on the secondary winding, dividing the winding in sections to obtain various resistances.

Code No.	No. of Coils	No. of Windings Each Coil	Winding Resistances Ohms		Impedance Ratio	Dimensions, Inches Coil
			Primary	Secondary		
49A	1	2	1.65	31	1 to 15	3 ⁵ / ₈ x 1 ³ / ₈

REPEATING COILS—Continued



No. 50A

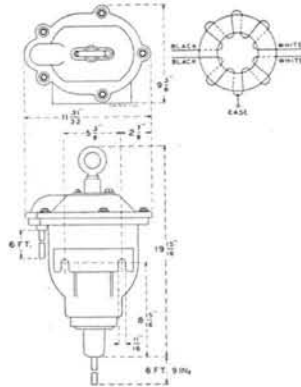

Wiring Diagram No. 50A

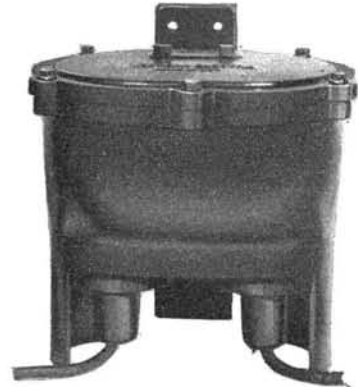

No. 121A

NOS. 50A AND 121A TYPES

The Nos. 50A and 121A Types are intended for use in telephone systems operated in connection with high voltage transmission lines.

50A Consists of two windings on a steel core which are insulated from each other and the line winding is insulated from the case to withstand high potential surges of 25,000 volts for one minute. The average D.C. resistance of the subscriber set winding is 31 ohms and of the line winding is 37 ohms. The impedance ratio between the subscriber set winding and the line winding is 1 to 1. The Coil is enclosed in a cast iron case with two porcelain bushings (large bushing P-143586, small bushing P-143585), for bringing out the leads from each winding. Case is furnished with six-foot leads. Dimensions of case 19 $\frac{5}{16}$ inches x 11 $\frac{31}{64}$ inches x 9 $\frac{3}{16}$ inches.

121A Similar to the No. 50A Coil except physical dimensions and dielectric strength. This Coil is designed to withstand a potential of 25,000 volts between the windings and between windings and case for a period of one minute.

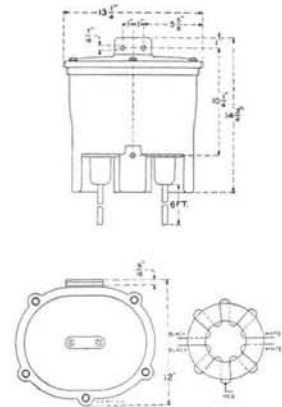

Wiring Diagram No. 121A

Phantom and Simplex Coils

The following Coils are intended for use in cord circuits and phantom and simplex circuits.

The Nos. 75 and 76A Types have two coils mounted on a wood base.

The No. 77A is a phantom terminating Repeating Coil equivalent to one-half the No. 76A.

The No. 78A is equivalent to one-half the No. 76A.

The No. 78A also consists of two resistance units enclosed in shell; each unit is non-inductively wound and is adjusted to have approximately the same D.C. resistance as the corresponding Repeating Coil windings. Intended for use at intermediate stations on phantom lines where one side of phantom circuit is terminated, the phantom circuit and the other side circuit going through.

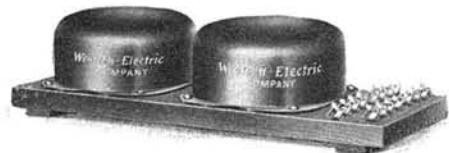

No. 76A Repeating Coil

Code No.	No. of Coils	No. of Windings Each Coil	Winding Resistances		Impedance Ratio	Dimensions, Inches	
			Primary	Secondary		Wood Base	Coil
75A	2	4	2 of 22	2 of 23	1 to 1	10 $\frac{3}{4}$ x 4
75B	2	4	2 of 21	2 of 14	1 to 1.62	10 $\frac{3}{4}$ x 4
75G	2	4	2 of 19	2 of 64	2.66 to 1	10 $\frac{3}{4}$ x 4
76A	2	4	2 of 20	2 of 21	1 to 1	10 $\frac{3}{4}$ x 4
77A	1	4	2 of 20	2 of 21	1 to 1	6 x 4
*78A	-	4	2 of 21	2 of 21	1 to 1	10 $\frac{3}{4}$ x 4
83B	1	4	2 of 22	2 of 23	1 to 1	2 $\frac{3}{16}$ x 4 $\frac{3}{16}$ x
102A	1	4	2 of 22	2 of 23	1 to 1	4 $\frac{3}{16}$ x 3 $\frac{7}{8}$

* Has two resistance units. See above notes.

NO. 94 TYPE

The following Coil is intended for use in magneto cord circuits to prevent ringing through

Code No.	No. of Coils	No. of Windings Each Coil	Winding Resistances		Impedance Ratio	Dimensions, Inches
			Primary	Secondary		
94E	1	4	2 of 20	2 of 20	1 to 1	11 $\frac{1}{16}$ x 5

RESISTANCES



No. 1



No. 18



No. 19

To meet changing conditions many types of Western Electric Resistances have been developed to meet varying circuit requirements. It is impractical to catalog them all here, the main types only being described. Further details on other types of Resistances will be supplied upon request.

NO. 1 TYPE

These Resistances are small, compact units having one winding on a brass core and are assembled with fibre heads. A brass shell protects the winding from injury. They are mounted by means of a round head machine screw passing through the core. The overall dimensions are: diameter $1\frac{1}{2}$ of an inch, length $1\frac{1}{4}$ inches. A mounting screw is furnished with the Resistance.

INDUCTIVELY WOUND

Code No.	Resistance, Ohms	Code No.	Resistance, Ohms	Code No.	Resistance, Ohms	Code No.	Resistance, Ohms	Code No.	Resistance, Ohms	Code No.	Resistance, Ohms	Code No.	Resistance, Ohms
1A	400	1C	500	1E	300	1G	3000	1J	20	1N	700	1R	250
1B	2500	1D	60	1F	1000	1H	200	1K	30	1P	5	1T	350
												1AN	120

NON-INDUCTIVE WINDINGS

Code No.	Resistance, Ohms	Code No.	Resistance, Ohms	Code No.	Resistance, Ohms	Code No.	Resistance, Ohms	Code No.	Resistance, Ohms	Code No.	Resistance, Ohms	Code No.	Resistance, Ohms
1L	100	1AF	22.0	1AS	*711	1BH	565	1CE	971	1DC	250	1DH	182.6
1W	2000	1AG	1000.0	1AT	606	1BU	663	1CL	1226	1DE	190	1DJ	2141.0
1AD	8.5	1AK	2.4	1AU	371	1BW	1917	1CY	482	1DF	337	1DR	4000.0
1AE	14.0	1AL	1	1BD	*1575	1CD	398	1DB	5000	1DG	1295		

* These Resistances have impregnated windings.

NO. 18 TYPE

Resistances of the No. 18 Type have a micanite core upon which a single winding is placed. The winding is protected by a covering of sheet mica. The ends of the winding are soldered to tinned terminal posts which are also used for mounting the unit. Each terminal post is provided with winding washers and a hexagonal nut.

The overall dimensions are: length $4\frac{3}{16}$ inches, width, $1\frac{3}{16}$ inches, thickness, $\frac{3}{8}$ inch.

The resistance values do not vary more than plus or minus 5 per cent from those rated in the table below. In some cases as noted, the resistance is held to even closer limits. Each resistance will dissipate six watts continuously without injury from heating.

The mounting plates listed elsewhere under the heading of "Mounting Plates," provide for assembling these resistances in compact groups and when so mounted the terminals are conveniently located for making soldered connections.

Code No.	Resistance Ohms	Code No.	Resistance Ohms	Code No.	Resistance Ohms	Code No.	Resistance Ohms	Code No.	Resistance Ohms	Code No.	Resistance Ohms	Code No.	Resistance Ohms
18A	37	18Q	110	18AG	226	(b) 18BD	580	18CJ	5	(b) 18DS	1700		
18B	40	18R	10	18AH	320	(b) 18BE	20	18CK	440	18EA	9000		
18C	83	18S	20	18AJ	400	(b) 18BF	284	18CN	800	18EC	6000		
18D	120	18T	50	18AK	60	(b) 18BG	400	(b) 18CR	2000	(b) 18EE	128		
18E	140	18U	100	18AL	4	(b) 18BH	1000	(d) 18CU	.8	(b) 18EF	2500		
18F	150	18Y	90	18AM	250	18BJ	1200	18CW	1.6	18EM	8600		
18G	200	18Z	67	18AN	350	(b) 18BK	1300	(b) 18DA	1510	18ES	4800		
18H	210	18AA	95	(b) 18AP	500	18BL	750	18DB	3000	(a) 18EU	500		
18J	30	18AB	45	18AR	380	(b) 18BM	1000	(b) 18DC	325	18EW	5000		
18K	80	18AC	500	18AT	1600	(b) 18BR	60	(b) 18DG	426	18FC	4000		
18L	170	18AD	240	(b) 18AW	40	(b) 18BT	200	18DH	700	(c) 18FF	43.2		
18M	53	18AE	600	18AY	2.4	(b) 18BU	300	(b) 18DJ	15	18FG	8030		
18N	180	18AF	300	18BA	2000	(b) 18BV	100	(a) 18DP	18.75	(b) 18FL	620		
18P	130												

NO. 19 TYPE

These resistances are similar in construction to the No. 18 Type and may be mounted on $\frac{7}{16}$ inch horizontal centers and $1\frac{3}{4}$ inch vertical centers. They differ from the No. 18 Type in that two windings are provided and the end of each winding soldered to a center terminal. The two outside terminals are used as mounting posts. The resistance values do not vary more than plus or minus 5 per cent from those rated below and in some cases, as noted, the variation is held to closer limits.

Code No.	Resistance Ohms	Code No.	Resistance Ohms	Code No.	Resistance Ohms	Code No.	Resistance Ohms
19A	37 and 37	19AN	260 and 260	(b) 19DG	133 and 770	(b) 19GB	80 and 85
19B	40 and 40	19AP	180 and 180	(c) 19DM	.2 and .4	(b) 19GC	75 and 110
19C	40 and 83	19AW	2.5 and 2.5	(f) 19DN	100 and 100	(b) 19GH	425 and 425
19D	83 and 83	19BA	900 and 900	19DP	.25 and .5	19GJ	300 and 500
19I	40 and 120	19BB	300 and 2300	19DR	1 and 2	19GL	300 and 300
19K	100 and 100	19BC	50 and 300	19DT	150 and 300	19GM	400 and 1000
19S	60 and 90	19BE	30 and 90	19DY	500 and 500	(c) 19KG	160 and 2990
19T	25 and 25	19BG	200 and 400	(b) 19EA	115 and 115	(c) 19KH	286 and 1325
19Z	120 and 120	19BJ	350 and 350	19EB	20 and 330	(c) 19KJ	467 and 512
19AD	150 and 150	19BL	1 and 1	19EC	650 and 1600	(c) 19KL	269 and 1490
19AH	240 and 240	(b) 19CA	185 and 770	19EW	800 and 800	19KM	84 and 6350
19AJ	200 and 200	19CN	100 and 200	(b) 19GA	400 and 600	(c) 19KN	146 and 651
19AM	50 and 50						

Note (a) Resistance value does not vary more than plus or minus $\frac{1}{2}$ %.

Note (b) Resistance value does not vary more than plus or minus 1%.

Note (c) Resistance value does not vary more than plus or minus 2%.

Note (d) Resistance value does not vary more than plus or minus 3%.

Note (e) Resistance value does not vary more than plus or minus 10%.

Note (f) The two parts are balanced for resistance within 1% of each other.

RESISTANCES—Continued

NO. 5 TYPE



No. 5

Resistances of the No. 5 Type have a single winding on a wooden spool. A threaded stud with a hexagonal nut is supplied for mounting. The overall dimensions are: diameter $1\frac{1}{16}$ inches and length $3\frac{1}{4}$ inches.

Code No.	Resistance (Ohms)	Code No.	Resistance Ohms
5G	10000	5K	750
5J	600	5M	2500

NO. 21 TYPE

The No. 21 Type have a single winding. The core is of brass with fibre heads. Equipped with wood screw for mounting. Resistance value does not vary more than plus or minus 5 per cent.

Code No. 21A has an approximate resistance of 6000 ohms; No. 21B has approximate resistance of 5000 ohms.

NO. 31A TYPE

An enamelled steel tube resistance mounted on a maple base 4 inches in length and 2 inches wide. The overall height is $1\frac{3}{4}$ inches. Two screw terminals are provided. 1200 ohms resistance.

NO. 34 TYPE



No. 34A Resistance

Variable resistance windings of this type are brought out at several points and a screw terminal provided for connecting at each point. The core is of brass with a fibre head. The insulation will stand 500 volts A.C. between the winding and the core. A No. 10 Round Head Iron Wood Screw 3 inches long is furnished for mounting.

Approximate dimensions: diameter, $2\frac{1}{16}$ inches, length overall $2\frac{3}{4}$ inches.

Terminal No.	34A	34B	34C	34G	34H
1	200	100	4	2900	320
2	400	200	8	2500	160
3	800	400	16	2200	80
4	1600	800	32	1700	40
5	3200	1600	64	1300	20
6	4600	500	900	10
7	6400	1000	700	..
8	12800	1500
Approximate total resistance (ohms) ..	30000	3100	3124	12200	630

NO. 36 TYPE

These resistances have four windings connected in series and brought out at four terminals. They are intended for use as artificial lines.

Code No.	Resistance (ohms)	
	1-3 and 2-4 (each)	1-2 and 3-4 (each)
36F	91	1071
36G	213	577
36J	742	367
36K	1330	336

NO. 38 TYPE

These resistances consist of a single carbon filament winding placed in a spiral groove on a cylindrical lavite core. Each end is fitted with a brass cap which serves both as a mounting lug and as a terminal. The lavite spool is covered, after winding, with insulating and moisture-proofing compound. The overall dimensions are: length, 3 inches; diameter, $\frac{23}{32}$ inch.



No. 38 Type

Code No.	Resistance Ohms	Code No.	Resistance Ohms	Code No.	Resistance Ohms	Code No.	Resistance Ohms
38A	48000	38H	10200	38T	70000	38AG	36500
38B	12000	38K	14200	38U	72500	38AH	25500
38C	15000	38L	17000	38W	100000	38AM	6440
38D	50000	38N	24000	38Y	4000	38AN	4580
38E	20000	38P	27240	38AA	10000	38AP	11060
38F	5330	38R	37500	38AB	30000	38AR	75000
38G	7300	38S	52500	38AC	7500		

RESISTANCE LAMPS

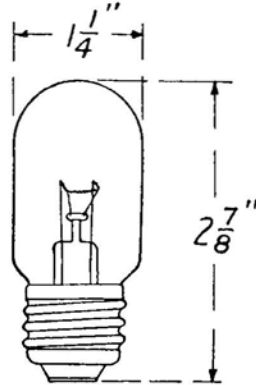

NO. 8 TYPE RESISTANCE LAMP

The No. 8 Type Resistance Lamps have a tungsten filament and are equipped with a medium screw base. The bulb is tubular in shape and is tipless. They are intended for use in ringing and battery supply leads for protective purposes.

The current limits at different voltages are given below and are subject in all cases to variations of plus or minus 15 per cent.

Code No.	Current at listed voltages (amperes)													
	125 V.	120 V.	100 V.	72 V.	70 V.	60 V.	45 V.	30 V.	24 V.	20 V.	15 V.	10 V.	6 V.	5 V.
8A	*.370	*.196	*.138
8B	.089064034
8C	.130095048
8D	.222163085
8E220176086
8F680530350
8G529379178
8H325212120
8J830	.700390

* Plus or minus 5%.

These Lamps are recommended in place of the No. 6 Type.

RETARDATION COILS

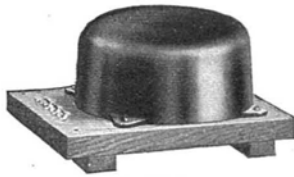

No. 5AA

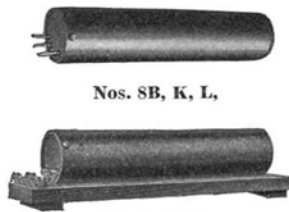

Nos. 8B, K, L,

Nos. 8 C, M



No. 5AF

NO. 5 TYPE

Code No.	No. of Windings	Resistance (Ohms)	Use	Size of Coil or Base (Inches)
5A	2	20.5 (each)	As balancing coil in connection with duplex sets. In standard composite sets. In phantoming magneto subscribers' circuits.	5½ x 5½
5C	2	250 (each)		7½ x 3½
5W	1	146		6 x 4
5AA	2	74 (each)		11 x 8½
5AF	4	330 (total)		3⅞ x 3⅞

NO. 8 TYPE

8B	2	85 (each)	No. 8C unmounted	9½ x 1⅞
8C	2	85 (each)	Mounted	10¾ x 2
8K	2	35 (each)	Unmounted	9½ x 1⅞
8L	2	175 (each)	Unmounted	9½ x 1⅞
8M	2	165 (each)	Mounted	10¾ x 2
8R	1	100	Mounted—For use in Morse Generator Taps	9½ x 2¾



No. 12G



Nos. 12A, 12L and 12S



No. 12M

NO. 12 TYPE

Code No.	No. of Windings	Resistance (Ohms)	Use	Size of Coil or Base (Inches)
12A	1	165	{ Operator's telephone circuit in Nos. 1, 9 and 10 Switchboards and Nos. 101 and 102 Private Exchanges.	6 x 1¾
12E	1	230		6 x 1¾
12G	1	2.3	{ Nos. 1312A and 6023A Telephone Sets. Has a movable core for varying impedance.	3⅓ x 1 x 1⅓
12L	1	400		high
12M	1	2.3	Operator's telephone circuit No. 4 P.B.X.	6 x 1¾
12S	1	100	Nos. 1314A and E Telephone Sets.	3¼ x 1
12AB	1	165	{ Operator's telephone circuit in No. 550 P.B.X. Battery supply leads. 24 volt Operator's Telephone Set.	6 x 1¾
12AC	1	24		4¼ x 1⅞
12AD	1	140	{ Loud Speaking installations for Central Offices. In attendant's battery supply circuit of No. 2 Order Turret arranged for 18 volt operation.	4¼ x 1⅞
12AE	1	400		{ In attendant's battery supply circuit of No. 2 Order Turret.

RETARDATION COILS—Continued



No. 44 Type



Nos. 46M, N, P, W and Y



No. 47

NO. 44 TYPE

Code No.	No. of Windings	Resistance (Ohms)	Use	Size of Base (Inches)
44D	2 on each coil	83 each winding	Toll cord circuits	10 $\frac{3}{4}$ x 4
44F	4 on each coil	330 each coil—4 windings in series	A phantom circuit retardation coil	11 $\frac{3}{4}$ x 4 $\frac{3}{16}$
44K	2 on each coil	145 each winding	Linemens' signaling circuits	10 $\frac{3}{4}$ x 4

NOS. 46 AND 47 TYPES

The Nos. 46 and 47 Types of Retardation Coils are designed for general use in switchboard circuits. The No. 46 Types are arranged for front connections and are equipped with mounting lugs at one end for mounting on 1 $\frac{3}{32}$ inch centers by means of two screws. The overall dimensions are 3 $\frac{7}{8}$ inches long by 1 inch in diameter. The terminals project out $\frac{5}{16}$ of an inch.

The No. 47 Type differs from the No. 46 Type only in that they are arranged to mount on mounting plates. The overall dimensions are 4 $\frac{9}{16}$ inches long by 1 inch in diameter. The terminals project out $\frac{13}{16}$ of an inch.

Code No.	Code No.	No. of Windings	Resistance (Ohms)	Code No.	Code No.	No. of Windings	Resistance (Ohms)
46A	47A	1	600	46M	47M	2	125 (each)
46B	47B	1	150	46N	47N	2	100 (each)
46C	47C	1	200	46P	47P	2	500 (each)
46D	47D	1	250	46S	47S	1	40
46F	47F	1	500	46W	2	200 (each)
46G	47G	1	750	46Y	47Y	2	1000 (each)
46H	47H	1	350	46AA	2	20 (each)
46L	47L	1	400	47AC	1	2000
				47AD	2	875 (each)



No. 48A Retardation Coil



No. 54



No. 60 Type

NO. 48 TYPE

Code No.	No. of Windings	Resistance (Ohms)	Use	Size of Base (Inches)
48A	2 in series	100 (total)	Grounded composite circuits	6 x 4

NO. 54 TYPE

Arranged to mount on mounting plates. Enclosed in cross-talk proof shell. The shell is 4 $\frac{7}{8}$ inches long and $\frac{1}{2}$ inch diameter. The two mounting holes are on 1 $\frac{27}{32}$ inch centers.

Code No.	No. of Windings	Resistance (Ohms)	Use
54A	3	{ 1300 (inner) 85 (outer front) 85 (outer rear)	Combined battery feed and holding coil for No. 550 P.B.X. Switchboards.
54B	2	{ 400 (inner) 40 (outer)	Operator's telephone set in No. 550 P.B.X. Switchboards.
54D	2	85 (each)	In No. 505B Cordless and 550C P.B.X. Switchboards as a battery feed coil.
54R	1	165	Operator's telephone circuits.

RETARDATION COILS—Continued**NO. 60 TYPE**

Code No.	No. of Windings	Resistance (Ohms)		Use
		Max.	Min.	
60A	2	{ .23 .39	{ .19 .31	Intended for use with the Nos. 84F and 84G Interrupters to limit the noise in the battery due to the operation of the interrupter. Used with the Nos. 84F and 84G Interrupters to limit the inductive noise in the switchboard wiring and cable.
60B	2	{ 5.8 10.2	{ 4.8 8.4	

} 10½ x 3¼

NO. 71 TYPE

Code No.	No. of Windings	Approx. Resistance each winding (Ohms)	Use
71A	2	186.0	Telephone Repeater Equipments.
71B	2	0.9	Battery supply coil in Telephone Repeater Equipments.
71K	2	1.0	With 135 cycle ringing equipment.
71R	1	14.8	In the 156B Interrupter.
71S	2	1.5	Battery supply coils in telephone repeaters.

NO. 77A

The No. 77A Retard Coil is the same as the No. 5AA except that it is not mounted on a wooden base. It is intended for use in composite sets mounted on relay racks.

NO. 82G

This is a toroidal type coil enclosed in a sheet metal case arranged for relay rack mounting. Overall dimensions: Base, 3 x 1⅞ inches, height 3⅜ inches. The resistance of the winding is 3.5 ohms. Intended for use in telephone repeater equipments.

NO. 83A

A shell type coil enclosed in a cross-talk proof case furnished with two lugs for mounting. Has two windings of approximately 320 ohms each. Intended for use in the plate battery feed circuit of No. 1A Carrier Panel.

NO. 91 TYPE

Code No.	No. of Windings	Approximate Resistance of each winding (ohms)	Use
91A	2	0.9	Telephone repeater circuits.
91C	2	209	With composite ringer equipment.
91AY	2	180	In side circuits.

NO. 93 TYPE

The No. 93 Type is a toroidal type coil enclosed in a cross-talk proof case and is intended for use in basic networks.

Overall dimensions: Base 2⅜ x 2⅛ inches, height 3¼ inches.

Code No.	No. of Windings	Approximate Resistance (Ohms) of Windings
93A	2	11 (each)
93B	2	7 (each)

RETARDATION COILS—Continued

NO. 94 TYPE

Toroidal type coils enclosed in sheet metal cases provided with mounting lugs.

Code No.	No. of Windings	Approx. Resistance of Each Winding (Ohms)	Overall Dimensions Inches	Use
94A	2	160	$3\frac{3}{4} \times 1\frac{7}{16} \times 3\frac{3}{16}$	In low pass filter of the No. 21 Type 130 volt Repeater for phantom and physical circuits.
94E	1	322	$3\frac{3}{16} \times 1\frac{7}{16} \times 3\frac{3}{16}$	{ In low pass filters in telephone repeater sets. { In low pass filters in telephone repeater sets. { In side circuit at repeater installations.
94F	1	70		
94G	2	7.5		

NO. 105D

A toroidal type coil enclosed in a cross-talk proof case arranged for mounting on relay rack mounting plates. It has one winding of 29.2 ohms. Overall dimensions: Base, $2\frac{9}{16} \times 4\frac{3}{16}$ inches; height, $4\frac{7}{32}$ inches.

NO. 110A

A toroidal type coil enclosed in a cross-talk proof case arranged for mounting on mounting plates. It has two windings the approximate resistance of each being 83 ohms.

Intended for use with telephone repeaters.

Overall dimensions: Base, $2\frac{9}{16} \times 4\frac{13}{16}$ inches; height, $4\frac{7}{32}$ inches.



No. 116 Type Retard Coil



No. 135A Retard Coil

NO. 116A

A solenoidal type coil wound on a non-magnetic core. Has one winding of approximately 2.6 ohms resistance. Is intended for use in eliminating high frequency interference produced by pole changers, inter-rupters, ringing machines, etc., in telephone offices.

Overall dimensions: Diameter, $2\frac{3}{8}$ inches; height, $1\frac{1}{16}$ inches.

NO. 135A

A shell type coil enclosed in a cross-talk proof case arranged for mounting on mounting plates. Intended for use in voice frequency signaling equipment. Has two equal windings wound over a permalloy core. Approximate D.C. resistance of each winding is 175 ohms.

NOS. 148A AND 148B

High impedance shell type coils enclosed in metal cases. Have two windings arranged to mount on mounting plates. Recommended in place of the No. 75 Type Retardation Coils of corresponding code letter.

Code No.	Approx. Resistance of Each Winding Ohms
148A	3700
148B	2313

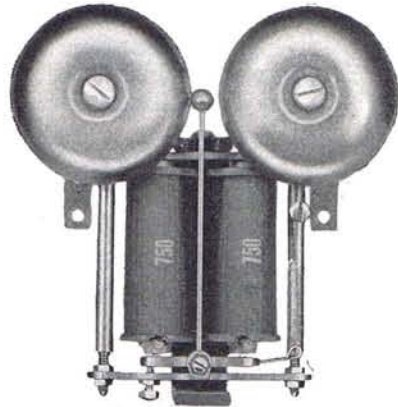
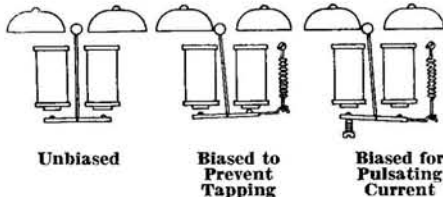
RINGERS**No. 8 Type Ringer****No. 78A Ringer****Unbiased****Biased to
Prevent
Tapping****Biased for
Pulsating
Current**

Western Electric Company ringers are wound with black enamel wire of Western Electric manufacture and are designed to give maximum ringing efficiency and at the same time offer high impedance to voice currents.

The gong posts are designed for engaging slotted gongs thereby assuring permanent gong adjustment.

Ringers (except harmonic ringers) are divided into two classes, namely: lock-nut adjustment and screw adjustment. In the screw type the position of the armature is adjusted with regard to the pole pieces, by means of a screw driver; and the position of the gongs is adjusted by means of an eccentric screw. These ringers are used in practically all the magneto telephones.

In the lock-nut type of adjustment a small wrench (for example: the No. 129 Tool) is used to alter the position of the armature with regard to the pole pieces and the eccentric screw form of gong adjustment is not employed. Ringers employing the lock-nut method of adjustment are used on central battery telephones.

All ringers employing the single screw form of adjustment are provided with screw terminals, whereas those employing the lock-nut adjustment have soldering terminals.

The ringers that are equipped with a biasing spring and armature stop screw or screws are intended primarily for use on pulsating (PC) or superimposed current (SC). However, such ringers are frequently operated on alternating current (AC) particularly in central battery systems.

Ringers equipped with a bias spring but without armature stop screws are intended for use on alternating current where it is desired to render the ringer less sensitive so that it will not tap, due to inductive disturbances, also to prevent operation on pulsating current.

Ringers which are not equipped with biasing springs are suitable for use only on alternating current.

RINGERS—Continued

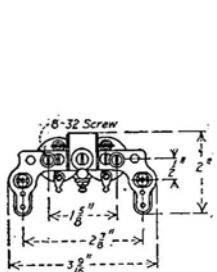

No. 8 Type Ringer.
Also Nos. 42 and 52
Types

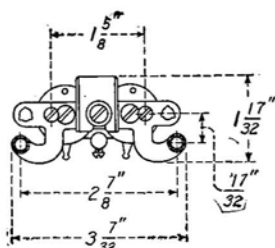

Nos. 68 & 72 Type Ringers

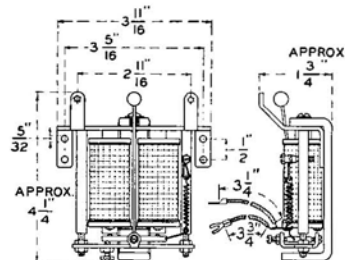
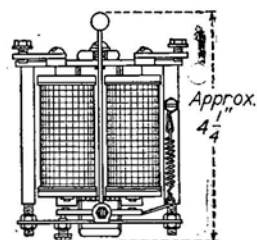
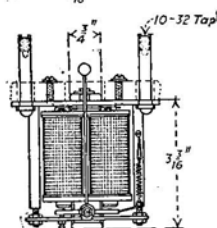

No. 78A & JA Ringers

NOS. 8, 42, 52, 68 AND 72 TYPES

Code No.	Ringer Code No.	Consists of—		Current Adjusted For	Biasing Feature	Type of Armature Air Gap Adjustment	Gong Posts—Woodwork Thickness	
		Re-sistance (Ohms)	Gong Code No. & Finish				Length	Thickness
8AG	8A	*1400	29A black	AC	Spring & Screw	Lock Nut	1 5/16	3/8
52AG	52A	**1000 and 3000	29A black	PC or SC	Spring & Screw	Lock Nut	1 3/64	9/16
††68JA	—	4300	—	AC	Spring & Screw	Lock Nut
(e)†72AG	72A	**1000 and 3000	29C unfinished	PC or SC	Spring & Screw	Lock Nut

Notes:

* The No. 8A Ringer was formerly wound to 1000 ohms resistance instead of 1400 ohms. The 1000 ohm and 1400 ohm ringers have the same impedance and may be used interchangeably in service.

** One spool of the Nos. 52 and 72 Type Ringers has a 3000 ohm supplementary non-inductive winding over the regular winding. The two windings are connected in series and the junction brought out to an extra terminal on the spool head for use in connection with an extension bell. These are the equivalent of using a 3000 ohm non-inductive resistance coil in series with a 1000 ohm, No. 8 Type Ringer.

† Offers high impedance to noise frequencies. Recommended in place of No. 8J.

(e) Recommended in place of No. 42A.

‡ The Nos. 68 and 72 Types are similar to the Nos. 8 and 42 Types respectively, of corresponding code letters, except arranged to mount 2 1/2 inch gongs having eccentric holes, in an inverted position, such as No. 29C.

NO. 78 TYPE

The No. 78 Type Ringers are similar to the No. 68 Type except arranged for use in Nos. 584 and 684 Type Subscriber Sets with Nos. 36, 37 and similar type Gongs.

Code No.	Approx. Resistance (Ohms)	Approx. Inductance at 900 Cycles (Henries)	Approx. Overall Dimensions
78A	1500	4	4 1/4 x 3 11/16 x 1 3/4
78JA	4300	30	4 1/4 x 3 11/16 x 1 3/4

RINGERS—Continued



No. 38 Type

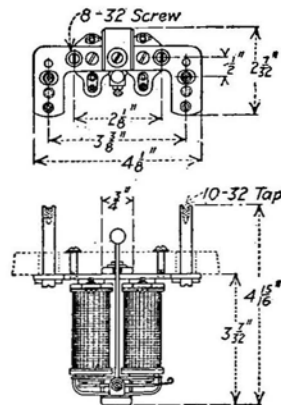
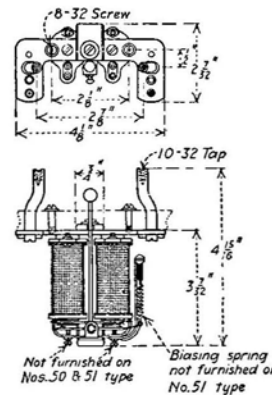

No. 51 Type

Nos. 38 and 45 Type Ringers
Also General Dimensions
of No. 47 Type
(with Biasing Spring)Nos. 49, 50 and 51 Type
Ringers

NOS. 38, 45, 47, 49, 50, 51 AND 53 TYPES

Code No.	Ringer Code No.	Type of Armature Air Gap Adjustment	Resistance (Ohms)	Biasing Feature	Current Adjusted For	Gong Posts		Gongs	
						Length	Woodwork Thickness	Code No. & Finish	Diameter Inches
38AG	38A	Single Screw	1000	None	AC	1 ³⁷ / ₆₄	5/8	26A black	3
38BG	38B	Single Screw	2500	None	AC	1 ³⁷ / ₆₄	5/8	26A black	3
38FG	38F	Single Screw	1600	None	AC	1 ³⁷ / ₆₄	5/8	26A black	3
45BG	*45B	Single Screw	2500	None	AC	1 ⁴³ / ₆₄	—	20 black	3
47BG	47B	Single Screw	2500	Spring	AC	1 ⁴³ / ₆₄	5/8	26A black	3
49BG	**49B	Single Screw	2500	Spring & Screw	PC	1 ⁴³ / ₆₄	5/8	29A black	2 1/2
51AG	**51A	Single Screw	1020	None	AC	1 ⁴³ / ₆₄	5/8	29A black	2 1/2
51BG	**51B	Single Screw	2500	None	AC	1 ⁴³ / ₆₄	5/8	29A black	2 1/2
51FG	**51F	Single Screw	1600	None	AC	1 ⁴³ / ₆₄	5/8	29A black	2 1/2
53AG	53A	Single Screw	1020	None	AC	1 ⁹ / ₁₆	5/8	29A black	2 1/2
53BG	53B	Single Screw	2500	None	AC	1 ⁹ / ₁₆	5/8	29A black	2 1/2
53FG	53F	Single Screw	1620	None	AC	1 ⁹ / ₁₆	5/8	29A black	2 1/2

* Treated to resist the action of moisture and fumes. Used in mine telephones.

** The Nos. 49, 50 and 51 Type Ringers have bent gong posts which permit of their use in woodwork drilled for ringers having three inch gongs; for example drilled for the No. 38 Type Ringer.

RINGERS—Continued

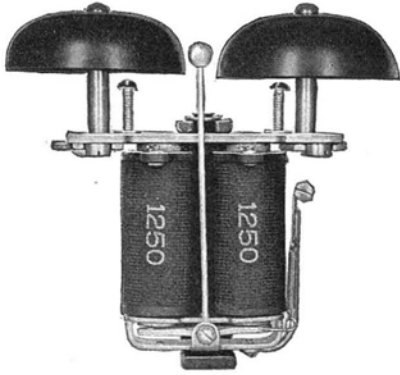

No. 54 Type

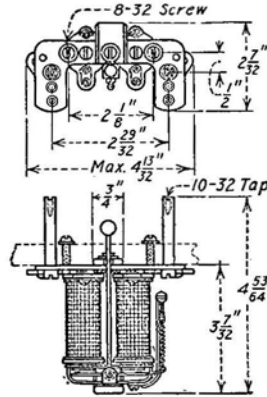

No. 55 Type Ringers also General Dimensions of Nos. 53 and 54 Types

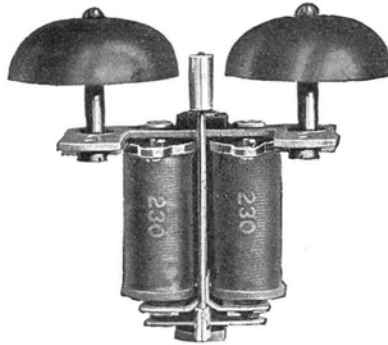

No. 41SG Ringer

NOS. 54 AND 55 TYPES

Code No.	Ringer Code No.	Armature Adjustment	Re-sistance (Ohms)	Biasing Feature	For Current	Gong Posts (Ins.) Drilling		Gongs and Finish	Diameter Ins.
54BG	54B	Single Screw	2500	Spring & Screw	PC	1 ⁹ / ₁₆	5 ⁸ / ₈	29A black	2 ¹ / ₂
55BG	55B	Single Screw	2500	Spring	AC	1 ⁹ / ₁₆	5 ⁸ / ₈	29A black	2 ¹ / ₂
55FG	55F	Single Screw	1600	Spring	AC	1 ⁹ / ₁₆	5 ⁸ / ₈	29A black	2 ¹ / ₂

HARMONIC RINGERS

41RG	41R	None	1800	None	16 ² / ₃ cycles	1 ⁹ / ₁₆	5 ⁸ / ₈	29A black	2 ¹ / ₂
41SG	41S	None	460	None	33 ¹ / ₃ cycles	1 ⁹ / ₁₆	5 ⁸ / ₈	29A black	2 ¹ / ₂
41TG	41T	None	285	None	50 cycles	1 ⁹ / ₁₆	5 ⁸ / ₈	29A black	2 ¹ / ₂
41UG	41U	None	200	None	66 ² / ₃ cycles	1 ⁹ / ₁₆	5 ⁸ / ₈	29A black	2 ¹ / ₂
41YG	41Y	None	285	None	60 cycles	1 ⁹ / ₁₆	5 ⁸ / ₈	29A black	2 ¹ / ₂

RINGERS—Continued

Ringer Indicators

GENERAL NOTES ON RINGERS

In all cases the length of the gong post is measured from the top of the heel iron to the surface on which the gong rests. This surface is $\frac{3}{64}$ inch lower than the lugs which project through the slots in the gong. Spacers to adapt the ringers to $\frac{3}{8}$ or $\frac{1}{2}$ inch woodwork will be furnished if specified in order. In ordering, specify whether ringer is to be mounted in a wooden or metal type of set.

RINGER INDICATOR

Code No. 1A—A manually restored indicator, consisting of a metal frame with a slide which is arranged to engage the clapper rod of a ringer.

Operation of ringer exposes a white surface on the frame.

Standard method of wording orders: 1—1A Ringer Indicator.

Replacement Parts of Ringers

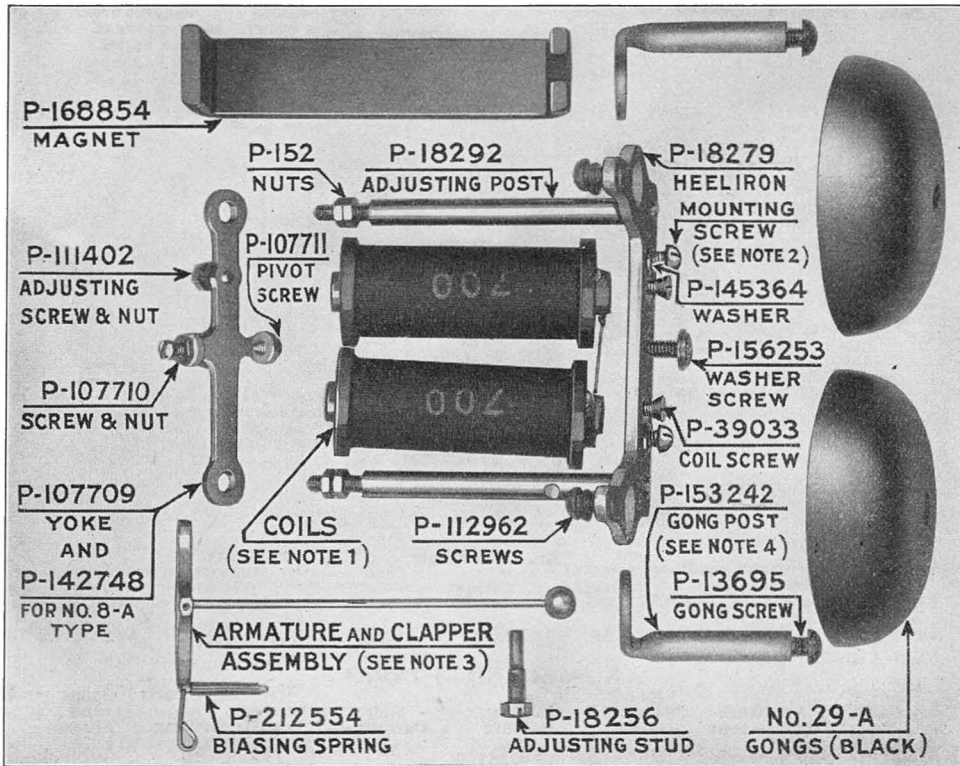

	Ringer Nos.		
	8AG	42AG	52AG
Coils (Note 1)	P-214148 (700 ohms)	P-218234 (500 ohms) P-214153 (500-3000 ohms)	P-127418 (500 ohms) P-214154 (500-3000 ohms)
Mounting Screw (Note 2)	P-145367	P-145366	P-145369
Armature and Clapper Assembly (Note 3)	P-146329	P-146329	P-146328
Gong Post (Note 4)	P-153242	P-153242	P-156829

Gongs for various type ringers are listed with the code numbers.

RINGERS

Replacement Parts—Continued

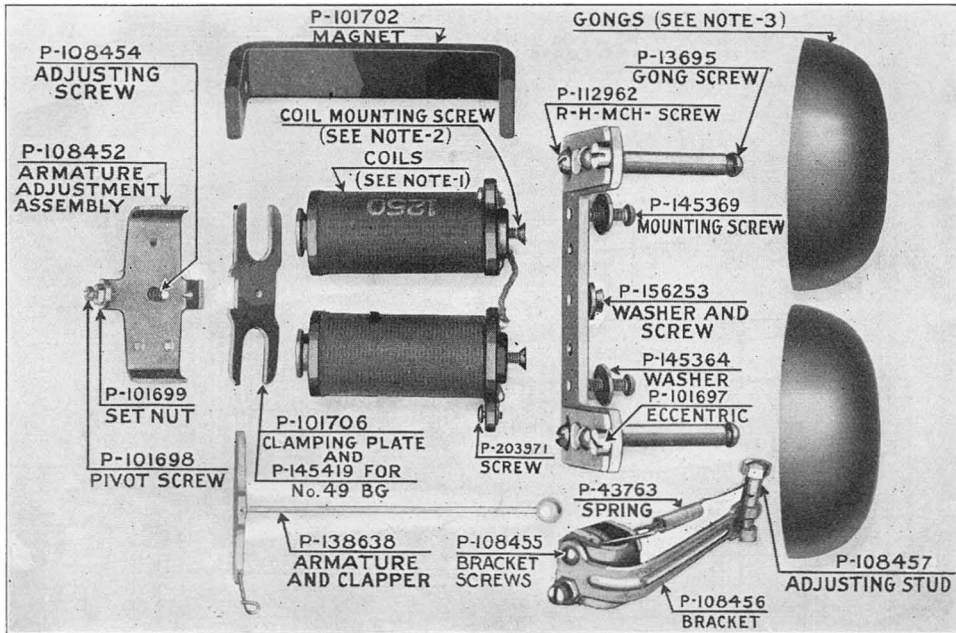

Repair parts for the Nos. 38, 47, 50, 51, 53 and 55 Type Ringers are the same as shown above with the following exceptions:

Description	Ringer	Ringer	
Coils (Note 1)	38AG	38BG	
	47AG	47BG	
	51AG	49BG	
	53AG	50BG	P-133727
		51BG	
		53BG	
		54BG	
		55BG	P-214145
			(1250 ohms)
	51JG	P-127280	
		(25 ohms)	
Coil Mounting Screw (Note 2)	38 Type	47, 49 Types	
	51 Type	P-38973	
	53 Type		50, 54 Types
35 Type P-109804		55 Type	

Gongs (Note 3) for various type ringers are listed with the code numbers.

Gong Post Assembly—38BG Ringer—P205284.

RINGERS

Replacement Parts—Continued

No. 45 BG Ringer

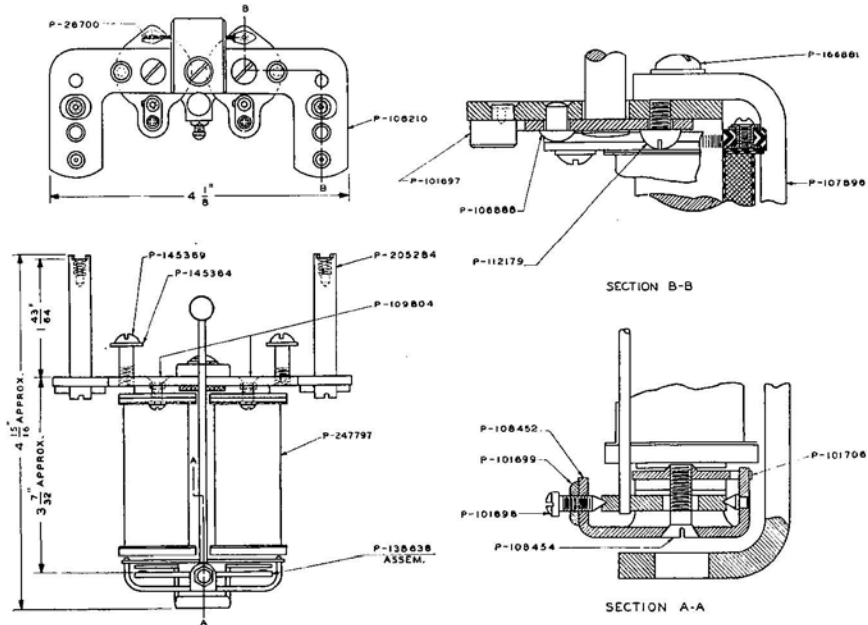

Piece Part	No. Required	Material	Name
P-108452	1	—	Armature Adj. Assem.
P-138638	1	—	Clapper & Arm. Assem.
P-205284	2	—	Gong Post Assem.
P-247797	2	—	Coil Assem.
P-26700	1	—	Conductor, 1½" long
P-101697	2	Brass	Eccentric
P-101698	1	Brass	Pivot Screw
P-101699	1	Brass	Hex. Nut
P-101706	1	Brass	Clamping Plate
P-106888	2	Iron	Rivet
P-166881	1	Iron	Washer H. M. Screw
P-108210	1	Steel	Heel Iron
P-108454	1	Brass	F. H. Mach. Screw
P-109804	2	Iron	F. H. Mach. Screw
P-112179	2	Brass	R. H. Mach. Screw
P-107896	1	—	Magnet

* Part of P-205284.

Gongs for various type ringers are listed with the code numbers.

RINGERS

Replacement Parts—Continued

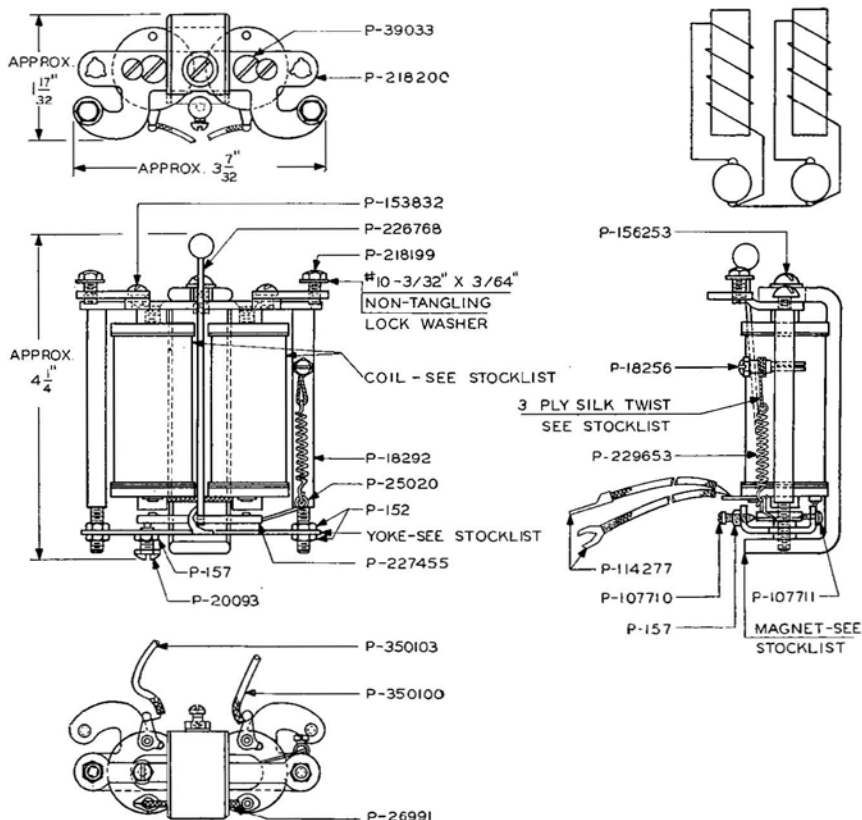

No. 68JA Ringer

Piece Part	No. Required	Name
P-39033	2	F.H.M. Screw
P-218200	1	Heel Iron
P-350103	1	Cord Conductor 6 1/2" long
P-350100	1	Cord Conductor 6 1/2" long
P-114277	2	72 Cord Tips
P-18292	2	Adjusting Post
P-152	4	Hex. Nut
P-157	2	Hex. Nut
P-20093	1	Adjusting Screw
P-156253	1	Washer H.M. Screw
P-26991	1	Sleeve Conductor 1 3/8" long
P-18256	1	Adjusting Stud
P-107710	1	Pivot Screw
P-107711	1	Pivot Screw
	1	3-Ply Spun Brown Twist 3 1/2" long
P-229653	1	Biasing Spring
P-238288	1	Magnet
P-107709	1	Yoke
P-25020	1	Hook
P-227455	1	Armature Assembly
P-238287	2	Coil
P-226768	1	Clapper Assembly

Gongs for various type ringers are listed with the code numbers.

RINGERS

Replacement Parts—Continued

Nos. 78JA Ringers

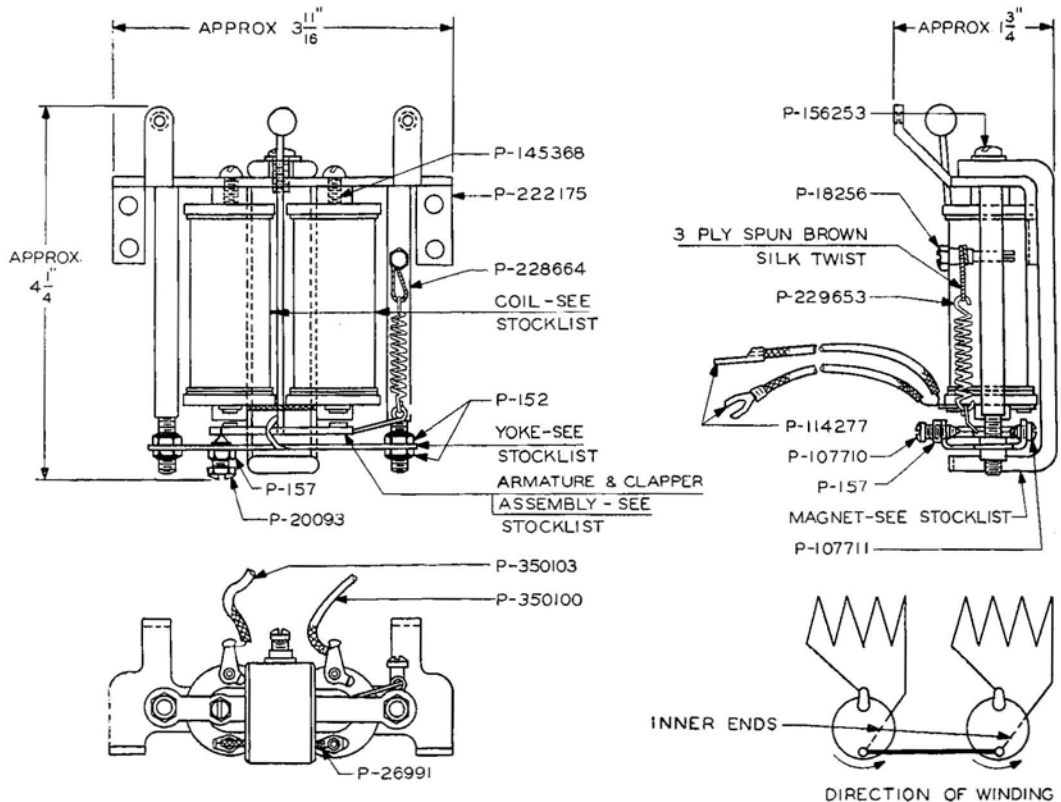

Piece Part	No. Required	Name
P-145368	2	R.H.M. Screw
P-222175	1	Heel Iron Gong Mounting
P-350100	1	Cord Conductor Black 4 3/4" long
P-350103	1	Cord Conductor Red 5 1/4" long
P-114277	2	72 Cord Tip
P-228664	2	Adjust. Post
P-152	4	Hex. Nut
P-157	2	Hex. Nut
P-20093	1	Adjust. Screw
P-156253	1	Washer H.M. Screw
P-26991	1	Sleeve Conductor 1 3/8" long
P-18256	1	Adjust. Stud
P-107710	1	Pivot Screw
P-107711	1	Pivot Screw
P-229653	1	3-Ply Spun Brown Twist 3 1/2" long
P-238288	1	Biasing Spring
P-107709	1	Magnet
P-238287	2	Yoke
P-227456	1	Coil
		Armature and Clapper Assembly

Gongs for various type ringers are listed with the code numbers.

SIGNALS



No. 4E, No. 2 Mounting



No. 34A shown in the operated position



No. 32A



No. 42A Signal on No. 79 Mounting

NO. 4 TYPE

The No. 4 Type Signal has two coils. When operated, an aluminum signal is lifted into a visible position, it being covered by the mounting when unoperated. The aluminum signal target is supplied numbered in black as per order but will be supplied unnumbered unless otherwise specified. The No. 4A and No. 4E have a local contact which is closed when the signal is operated. The No. 4J is not provided with a local contact; the armature of the No. 4J is provided with a counterweight to balance the target.

This type is used principally as a line signal in private branch exchanges employing magnetic signals and operating on a central battery basis. Mounts on $1\frac{3}{8}$ inch centers.

Code No.	Resistance (Ohms)	Used with Signal Mounting
4A	98	} Nos. 2, 3, 94A, 95A
4E	500	
4J	400	

NO. 32 TYPE

The face of the No. 32 Type Signal is entirely black in the unoperated positions. When operated, a target is lifted into position so as to register white in the slots in the signal face, thus giving visible indication of operation. These signals have no local contacts. Mounts on $1\frac{1}{16}$ inch centers.

The Nos. 32B and 32C have a single winding; the No. 32A has two windings, one inner inductive winding of 50 ohms and an outer non-inductive winding of 100 ohms. The resistance value given in the table below is for both windings in parallel.

Code No.	Resistance (Ohms)
32A	33
32B	50
32C	525

NO. 34 TYPE

The No. 34 Type Signal has one coil with a single winding. When operated, an aluminum target is displayed as shown in the illustration. In the unoperated position, the opening in the signal face is not filled by the target. The signals will be furnished unnumbered unless otherwise specified, but, if so ordered, they will be supplied with black numbers on the aluminum target. When so desired, No. 129 Type Number Plates may be used with these signals and the number on the target omitted.

Each No. 34 Type Signal has a single local contact which is closed in the operated position.

These signals are used as line signals in the No. 9 Switchboard and in the trunk circuits of the old No. 105 Magneto Switchboard. They will mount on $1\frac{1}{8}$ inch horizontal and $1\frac{3}{8}$ inch vertical centers.

Code No.	Resistance (Ohms)	Used with Signal Mounting
34A	86	} Nos. 34, 60, 61, 62, 96, 97
34B	300	
34C	900	
34D	525	

NO. 41 TYPE

The No. 41 Type Signal is similar in general construction to the No. 34 Type. The coil has two parallel windings; the resistance given below is the value of each individual winding. These signals will mount on $1\frac{5}{16}$ inch horizontal and $1\frac{3}{8}$ inch vertical centers. Numbered in black on the aluminum target when so specified in order but otherwise furnished unnumbered.

Each No. 41 Type Signal is provided with a cross-talk proof shell.

This type signal has a local contact, both sides of which are brought out to terminals. The No. 41A Signal has this contact normally open; the No. 41B is arranged so that the contact is closed when the signal is in the unoperated position.

These signals are used in the cord circuits of the No. 9 Switchboards.

Code No.	Resistance (Ohms)	Used with Signal Mounting
41A	30 (each)	} No. 60
41B	100 (each)	

NO. 42A TYPE

The No. 42 Type Signal has one coil with a single winding. There are no local contacts. The illustration shows all but three of the signals in the No. 79 Mounting in their unoperated position. The aluminum target is lifted into place when the signal is operated as shown in the cut. A designation strip on the mounting is used for numbering the signals.

The mounting centers are: horizontal, $\frac{7}{16}$ inch; vertical, $\frac{7}{8}$ inch.

The No. 42 Type is used as a busy signal with multiple toll line jacks; they mount in the same centers as the jacks.

Code No.	Resistance (Ohms)	Used with Signal Mounting
42A	100	Nos. 75, 77, 78, 79, 82, 83, 105

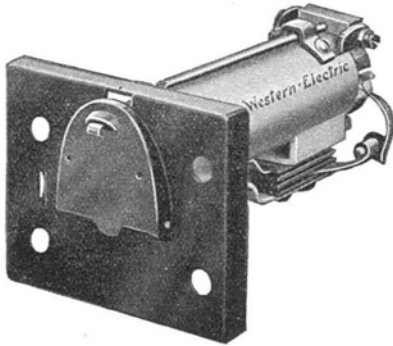
SUPERVISORY SIGNALS AND SIGNAL MOUNTINGS

No. 34C Supervisory Signal
Shutter Restored
(on No. 93A Mounting)

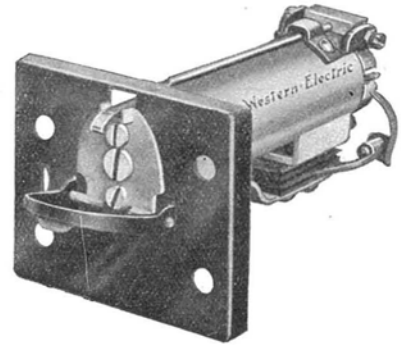

No. 34C Supervisory Signal
Shutter Operated

Supervisory Signals

Code No.	Approximate Resistance Ohms	Description	Mountings No.
34C	330	A manually restored, electrically operated shutter type magneto supervisory signal, to be used in connection with No. 22 Type Combined Jack and Signal or as a line signal.	90A, B, C, 93A, 99A

Note. For replacement parts, refer to No. 22 Type "Combined Jack and Signal" shown elsewhere.

SIGNAL MOUNTINGS

The following Mountings are those commonly used with the various classes of signals as listed. They are metal Mountings with black finish faces.

Code No.	For Signals	No. of Signals per Strip	Size of Plate, Inches
61	34 & 35 Types	20	24 $\frac{9}{16}$ x 1 $\frac{3}{8}$
95A	(Mounts 3 No. 56 Drops and 7 No. 4 Type Signals)		13 $\frac{3}{16}$ x 1 $\frac{3}{8}$
97	34 Type	15	21 $\frac{3}{4}$ x 1 $\frac{3}{8}$

FOR COMBINED JACKS AND SIGNALS

80B	2, 3, 6, 7, 8, 9, 12	1	1 $\frac{1}{8}$ x 2 $\frac{1}{4}$
80C	4, 5, 11	1	1 $\frac{1}{8}$ x 2 $\frac{1}{4}$
80E	9D	1	1 $\frac{1}{8}$ x 2 $\frac{1}{4}$
81E	2, 3, 6, 7, 8, 9, 12	5	6 $\frac{23}{32}$ x 1 $\frac{3}{4}$
88B	2, 3, 6, 7, 8, 9, 12	10	11 $\frac{31}{32}$ x 1 $\frac{7}{8}$
89B	22, 23, 26, 27	5	6 $\frac{23}{32}$ x 1 $\frac{3}{4}$
92B	22, 23, 26, 27	1	1 $\frac{1}{8}$ x 2 $\frac{1}{4}$
92C	24, 31	1	1 $\frac{1}{8}$ x 2 $\frac{1}{4}$

FOR SUPERVISORY SIGNALS

80D	10, 13	1	1 $\frac{1}{8}$ x 2 $\frac{1}{4}$
90C	34C	5	6 $\frac{23}{32}$ x 1 $\frac{3}{4}$

Signal Plugs



Nos. 1, 2, 3 and 4 Type Signal Plug

The Nos. 1, 2, 3 and 4 Types are metal plugs which are inserted in a jack to designate a change of number, line temporarily disconnected, line arranged for calling only, or similar purposes.

Heads are covered with pigment lacquer finishes. The white heads of the Nos. 1A and 3A may be written upon.



Nos. 5 and 6 Type Signal Plug

FOR NO. 49 AND NO. 193 JACKS

Code No.	Color of Head	Dimensions, Inches	
		Diameter of Head	Overall Length
1A	White	$\frac{27}{64}$	$\frac{35}{64}$
2B	Red	$\frac{23}{64}$	
2D	Black	$\frac{23}{64}$	
2E	Yellow	$\frac{23}{64}$	
2H	Light Green	$\frac{23}{64}$	

FOR NO. 92 JACKS

Code No.	Color of Head	Dimensions, Inches	
		Diameter of Head	Overall Length
3A	White	$\frac{23}{64}$	$\frac{33}{64}$
4B	Red	$\frac{5}{16}$	
4D	Black	$\frac{5}{16}$	
4E	Yellow	$\frac{5}{16}$	
4H	Light Green	$\frac{5}{16}$	

The Nos. 5 and 6 Type Signal Plugs are used as line markers for indicating lines in trouble, spare jacks, etc. The metal shank is slotted in two directions and the head has a white celluloid face which may be written upon. The sides of the plug head are colored as indicated in the table.

The No. 7A Signal Plug has black finish face and is engraved with one or two letters, $\frac{5}{32}$ in. high, or three letters, $\frac{1}{8}$ in. high as per order. Engraving is filled white.

Code No.	Color of Face	Color of Side Head	Length of Side Head	Overall Length	Diameter Inches
FOR NO. 49 AND NO. 193 JACKS					
5A	White	Red	$\frac{1}{2}$	$1\frac{1}{32}$	$\frac{11}{32}$
5B	White	White	$\frac{1}{2}$	$1\frac{3}{32}$	$\frac{11}{32}$
5C	White	Blue	$\frac{1}{2}$	$1\frac{3}{32}$	$\frac{11}{32}$
7A	Black	$2\frac{1}{32}$	$\frac{11}{32}$
FOR NO. 92 JACKS					
6A	White	Red	$\frac{1}{2}$	$1\frac{1}{32}$	$\frac{11}{32}$
6B	White	White	$\frac{1}{2}$	$1\frac{3}{32}$	$\frac{11}{32}$
6C	White	Blue	$\frac{1}{2}$	$1\frac{3}{32}$	$\frac{11}{32}$

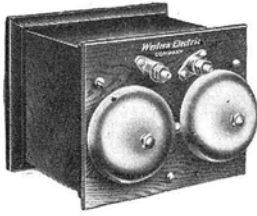
SUBSCRIBER SETS**Extension Bells**

**Nos. 43 & 127 Type
Extension Bells**

**FOR ALTERNATING, PULSATING AND
HARMONIC CURRENT**

These Subscriber Sets are intended for auxiliary use as Extension Bells in connection with wall, desk and transmitter arm telephones or for use instead of regular ringers furnished in the telephone. The resistance of the extension bells should be the same as that of the ringers used on the same line.

NO. 43 TYPE

This subscriber set consists of a ringer mounted on the cover of a box. The standard finish is golden oak.

Code No.	Ringer	Approx. Resistance Ohms	Gongs	Dimensions Inches	Operating Current
43F	6A	1400	29A	5 $\frac{5}{8}$ x 5 $\frac{7}{8}$ x 4 $\frac{5}{8}$	AC biased to prevent tapping.

NO. 127 TYPE

These Subscriber Sets consist of a ringer mounted on the cover of a box. Approximate overall dimensions 6 $\frac{1}{2}$ " wide x 5 $\frac{7}{8}$ " high x 4 $\frac{1}{8}$ " deep. The standard finish is golden oak.

Code No.	Ringer	Approx. Resistance Ohms	Gongs	Condensers	Operating Current
127A	6A	*1400	29A	21F	AC biased to prevent tapping.
127E	38A	1020	26A	—	AC not biased.
127F	38B	2500	26A	—	AC not biased.
127G	38F	1620	26A	—	AC not biased.

* The No. 6A Ringer (D.C. resistance 1400 ohms) has the same impedance as the older types of 1000 ohm ringers and are therefore interchangeable in service.

Note. Each set is equipped with No. 2A Binding Posts for making line connections.

NO. 342 TYPE—LOUD RINGING

These Subscriber Sets (Extension Bells) consist of the No. 392 Type set, described below, mounted on a No. 152A Backboard, which protects the bell from falling water and other substances. For illustration see "Backboards."

Code No.	Subscriber Set Used
342G	392G
342H	392H
342J	392A
342K	392B

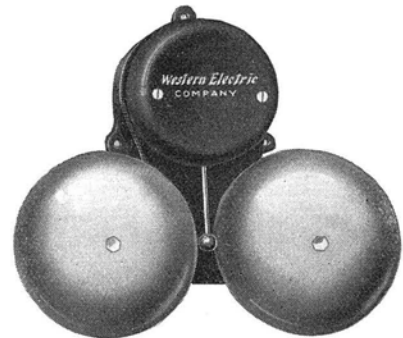

No. 392 Type

NO. 392 TYPE—LOUD RINGING

The No. 392 Loud Ringing Subscriber Set is used extensively in factories, mines, and warehouses in connection with police telephones and other places where the ordinary telephone ringer is inadequate either due to excessive local noises or to the fact that the service conditions are such that the bells must be capable of being heard at a considerable distance.

In addition to their use in connection with telephones, these loud ringing subscriber sets are used in school, factory, police, mine, etc. signalling systems. For this service they have the advantage over direct current bells in that no battery is required. See Hand Generator Boxes.

SUBSCRIBER SETS

Extension Bells

NO. 392 TYPE—LOUD RINGING—(Continued)

The windings of the No. 392 Type Bells are moisture-proofed and all metal parts are given a protective finish. These bells may be used on magneto telephone lines and in signalling systems as normally furnished, that is, without a condenser, but if they are to be bridged across a central battery telephone line a condenser as specified below, must be connected in series with the ringer.

The base is arranged for mounting a Condenser and the wiring is so arranged that a condenser may be easily connected in series with the ringer.

If a condenser is desired it should be so specified on the order.

The Nos. 392-A, B, G and H Subscriber Sets will be equipped with a biasing arrangement if specified in the order.

Code No.	Approx. Resistance Ohms	Diam. of Gongs Inches	Operating Current	Condensers Used	Replaces
392A	1000	6 (28A)	AC not biased	147A or 149A	292T & 292AD
392B	2500	6 (28A)	AC not biased	149D	292U & 292AC
392E	1600	6 (28A)	AC not biased	147A
392G	1000	8 (23A)	AC not biased	147A	292AB
392H	2500	8 (23A)	AC not biased	149D
392K	4500	6 (28A)	Pulsating biased	None	392D
*392L	2500	6 (28A)	AC biased	149D	392C & 392J

* Equipped with condenser.

NOS. 392 AND 342 TYPE SUBSCRIBER SETS—BIASING ATTACHMENTS

The Nos. 392 and 342 Type Subscriber Sets which are furnished unbiased may be equipped with the biasing attachment listed below thereby making them suitable for use on pulsating current. A screw driver and pliers are the only tools required for installing this attachment.

Code No.
D-76014

Biasing attachment for Nos. 392 and 342 Type Subscriber Sets.

NO. 584 TYPE

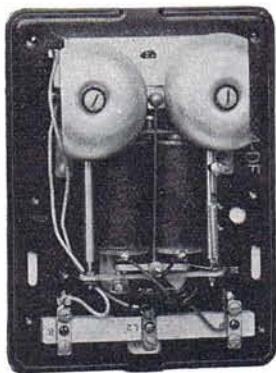

No. 584 DE-open



No. 584 DE-closed

Code No.	Ringer	Approx. Resistance Ohms	Gongs	Condensers Used	Replaces
584DE	78JA	4300	36A & 37A	1149B	43AD, 534DE & 584DD
584DF	78A	1500	36A & 37A	1149A	43AC, 534D, DC & DF

The following 584 Type Subscriber Sets are intended for use on non-polarized ringing lines and are biased to prevent tapping.

Code	Use
584DE	Intended for use as an Extension Ringer where a high impedance ringer is required.
584DF	Intended for use as an Extension Ringer where a low impedance ringer is required.

SUBSCRIBER SETS
Extension Bells—Continued
Replacement Parts for No. 392 Subscriber Sets

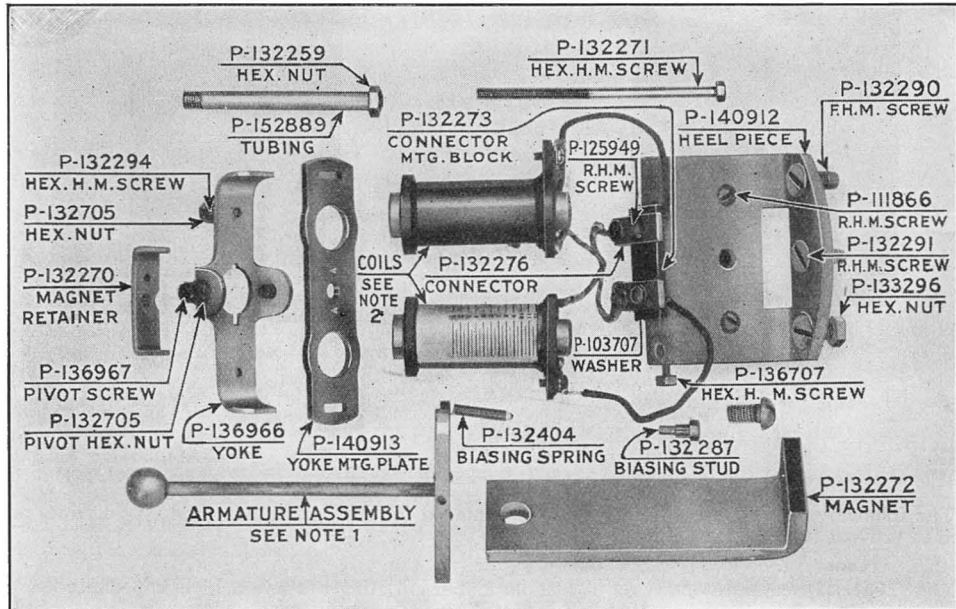
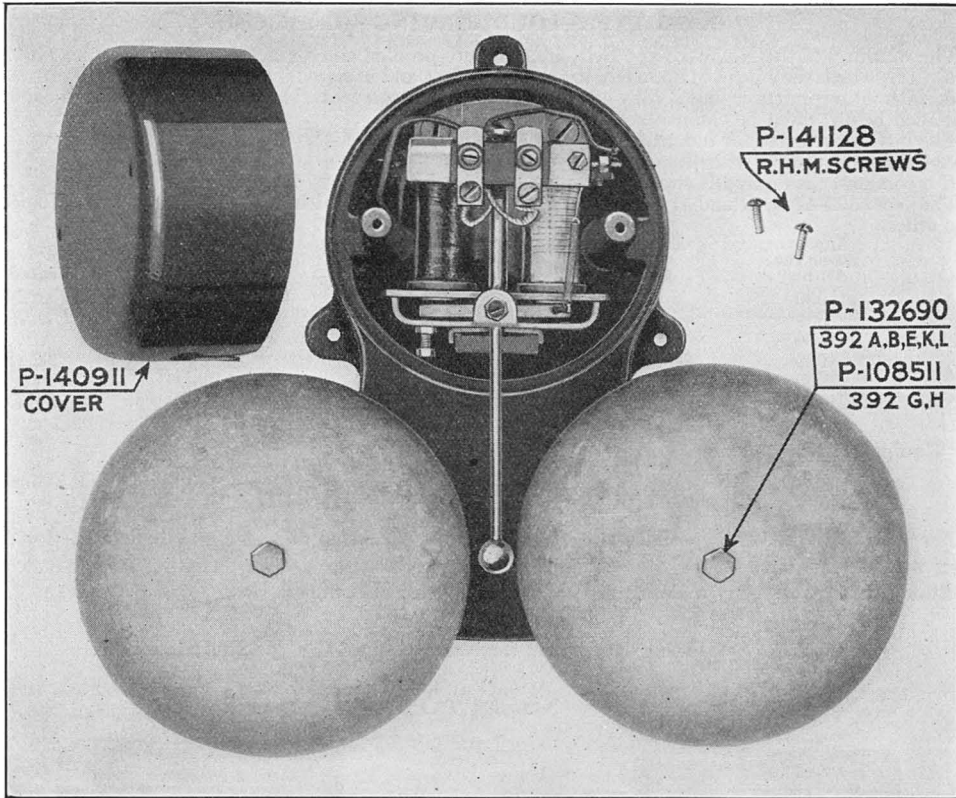

Coil and Armature Parts

Note 1. Armature assembly:	392A	392B	392E	392G	392H	392K	392L
	P-140919	P-140919	P-140919	P-140917	P-140917	P-140919	P-140919
Note 2. Ringer Coils:	P-145236	P-145237	P-145238	P-145236	P-145237	P-237182	P-145237

SUBSCRIBER SETS—Continued
Desk Set Boxes

MAGNETO

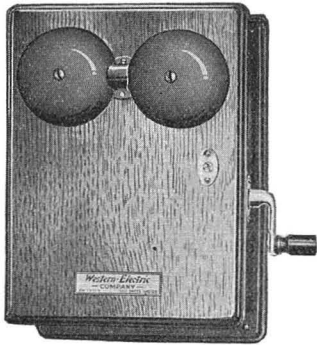

Nos. 300 and 315 Type Desk Set Boxes

The following desk set boxes, with the exception of the No. 315J, are equipped with ringers to operate on alternating current for code ringing service between the central office and the telephones and for code ringing between the telephones. The No. 315J is equipped with a pulsating current type ringer for four-party selective signalling from the central office and is also arranged for signalling the central office only.

The Nos. 300 and 315 type Desk Set Boxes may be used with the following apparatus or its equivalent:

- 1040AL Desk Stand
- 1020CC Transmitter Arm
- 1048 Type Transmitter Arms
- 1001C and H Hand Sets
- 1002AC Hand Set

These desk set boxes form a part of the Nos. 6003 and 6004 Type Telephones sets.

No. 300 and No. 315 Type Desk Set Boxes

NO. 300 TYPE WITH NO. 48 TYPE GENERATORS

Code No.	Composed of		Resistance	Condenser No.	For Ringing Service	Used on Lines as Regards Load
	Generator No.	Ringer No.				
300K	48A	38BG	2500	Code	Heavily
300L	48A	38FG	1600	Code	Medium
300M	48A	38FG	1600	21W	Code	Medium
300N	48A	38BG	2500	21W	Code	Heavily
NO. 300 TYPE WITH NO. 50 TYPE GENERATORS						
300AA	50A	38BG	2500	Code	Heavily
300AB	50A	38FG	1600	Code	Medium
NO. 315 TYPE WITH NO. 22 TYPE GENERATORS						
315E	22E	52AG	1000-3000	Code	Lightly
315H	22A	38AG	1020	Code	Lightly
315J	22E	49BG	2500	Four Party Selective	Lightly

Note. In addition to the above apparatus all of these sets are equipped with No. 13 Induction Coils and No. 29A Ringer Gongs.

REPLACEMENT PARTS FOR Nos. 300 AND 315 TYPE DESK SET BOXES

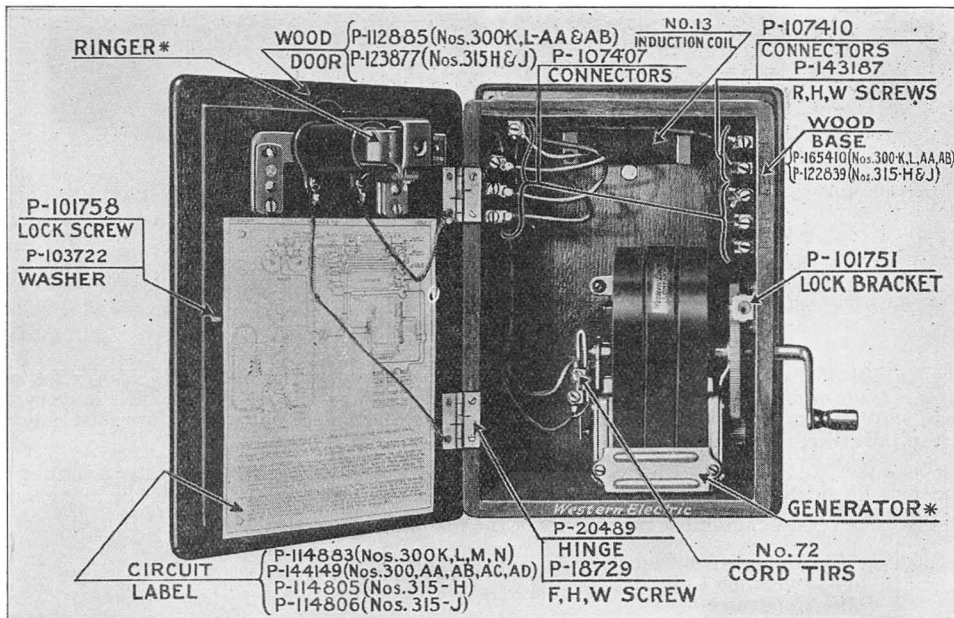

* **Note.** The ringer, generator, etc., are given in the above code number listings and their repair parts are shown elsewhere under their respective headings.

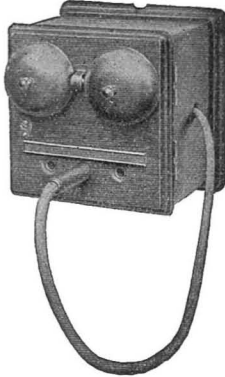
SUBSCRIBER SETS—Continued**CUT-IN STATIONS****For Magneto Bridging Service****No. 319 Type**

Used at an intermediate station in a toll line for the reception of signals and to cut off the line in either direction.

The No. 319 Type Cut-In Station, as listed below, is used with a separate local battery telephone which is wired to the plug. When the plug is not in any of the three jacks, the bell in the cut-in station box is bridged across the toll line and receives signals.

By inserting the plug in the middle jack, the operator places the telephone set in the "bridged" position and disconnects the ringer from the line. The direction from which the call is coming may then be ascertained and the plug removed from the center jack and inserted in either the right or left hand jack, as desired. With the plug in the right hand or left hand jack, the telephone set is connected to the line in that direction and cuts off the line in the other direction, at the same time placing the ringer across the disconnected portion of the circuit. A conversation may thus be held over the line in either direction and signals received from the end of the line not in the talking circuit.

Unbiased ringers are used in these sets.

The overall dimensions are: base, 7½" square and depth through bells approximately 6 inches. Woodwork, oak, gongs, black.

Code No.	Description
319E	1020 ohm ringers
319F	1620 ohm ringers
319G	2500 ohm ringers

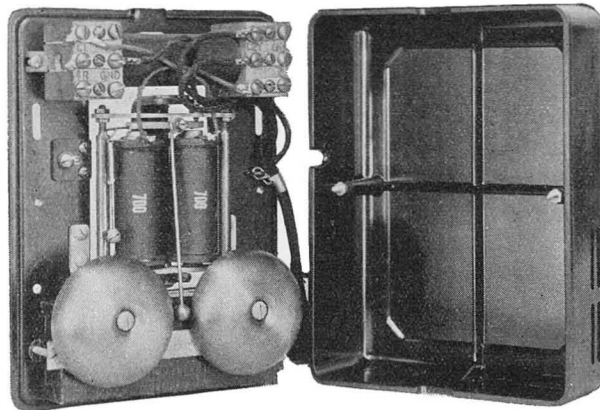
No. 584 Type**No. 584 Type Subscriber Set**

The No. 584A-3 Type is a small central battery Subscriber Set measuring overall 7 $\frac{3}{32}$ x 5 $\frac{1}{32}$ x 2 $\frac{3}{32}$ inches. The cover is made of molded bakelite and is finished in black. These Sets are also available in ivory, gray, old brass, statuary bronze, oxidized silver, medium gold and dark gold, but will be furnished only when specified in the order.

Replaces the No. 534A Subscriber Set and may be used with desk stands, transmitter arms and hand telephone sets for sidetone single and two-party selective A.C. service.

The No. 584A Type Subscriber Set consists of the following apparatus:

1	78A Ringer (1500 Ohms)	1	36A Gong
1	46C Induction Coil	1	37A Gong
1	149A Condenser		

Note: The No. 584A Type Subscriber Set may be converted for anti-sidetone service. For further information consult our nearest distributor.

SUBSCRIBER SETS

Anti-Sidetone

The Common Battery Subscriber Sets shown below are of the anti-sidetone type and have been developed by the Western Electric Company to improve transmission. The essential feature of this apparatus consists in the use of an anti-sidetone circuit whereby the sidetone is reduced by means of a third winding on the induction coil which winding includes a balancing resistance. On the average loop the transmitting improvement due to increase in talking volume obtained by this circuit and by using handset instruments averages about 3 db. The improvement in reception afforded by this circuit due to the reduction of the room noise in the telephone receiver results in an effective receiving gain which varies from 1 to 3 db., depending on the circuit conditions, battery supply and the amount of room noise present. The overall transmission improvement obtained by the use of these anti-sidetone sets at both ends of the connection is equivalent to that resulting from a reduction of trunk loss of from 3 to 10 db., depending on the instruments, circuit and room noise conditions. Inasmuch as the best results are obtained from a high battery supply, this new apparatus is most effective in short loops. Short loops being more or less common to congested areas in which the room noise level is liable to be very high, it is expected that the new sets will be of greater service in these areas.

New station equipments employing the anti-sidetone features have not been developed for all classes of service to date and we are including only those sets which are available at the present time. For information on Subscriber Sets for classes of service other than described below, write our nearest distributor.

It should be noted that the code numbers of these sets correspond with those of the old sidetone type for various classes of service, except that 100 has been added; i.e., No. 584C Subscriber Set (Sidetone) is No. 684C Subscriber Set (Anti-sidetone).

NO. 634 TYPE

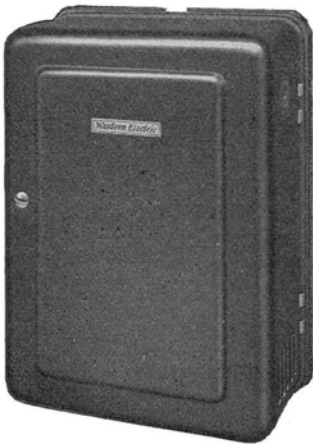

No. 634 Type Subscriber Set

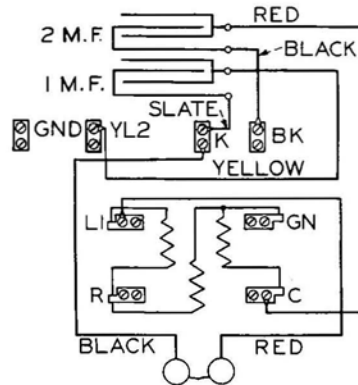

Wiring diagram for No. 634 E F G H

The following No. 634 Subscriber Sets are of the anti-sidetone type and are intended for use in existing two-party or four-party harmonic ringing systems. These sets are contained in metal boxes finished in black. Consists of apparatus as shown below.

Code No.	Ringer	Gongs	Condenser	Induction Coil	Remarks
634E	41S (33 $\frac{1}{3}$ cycles)	(*)	194A	146B	Replaces No. 534E
634F	41T (50 cycles)	(*)	194A	146B	Replaces No. 534F
634G	41U (66 $\frac{2}{3}$ cycles)	(*)	194A	146B	Replaces No. 534G
634H	41R (16 $\frac{2}{3}$ cycles)	(*)	194A	146B	Replaces No. 534H

(*) Two No. 29A or 29B Gongs.

Two No. 31A, 32A, or 33A Gongs will be furnished when specified.

SUBSCRIBER SETS

Anti-Sidetone—Continued

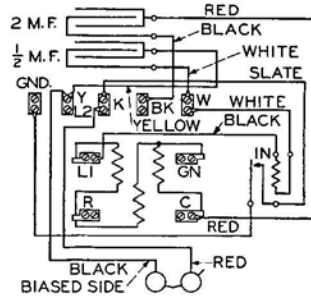

Wiring Diagram No. 634AR

The No. 634AR Anti-sidetone Subscriber Sets are intended for use in four-party selective ringing service in dial systems. Consists of apparatus as shown below.

No.	Ringer	Gongs	Condenser	Induction Coil	Relay	Remarks
634AR	72A	†2-29C	194B	146B	85N	Replaces No. 534AR

† Two No. 31C, 32C, or 33C Gongs will be furnished when specified.

Local Battery Anti-Sidetone Subscriber Sets

FOR USE IN COMMON BATTERY CENTRAL OFFICE AREAS

There has been made available a local battery anti-sidetone station equipment which is suitable for use in long central office loops, long P.B.X. extensions, foreign exchange lines, etc., where better transmission is desired than is afforded by the old type equipment. The new Subscriber Sets described below provide appreciable effective gains compared with sets using both the No. 13 and 46 Coils and proposed common battery anti-sidetone sets. These improvements are due to the use of the No. 62 induction coil, local batteries and special receivers which are further described in this catalog.

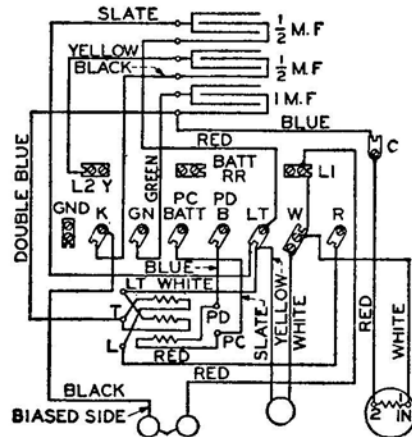

Wiring diagram No. 634BB Subscriber Set

NO. 634BB SUBSCRIBER SET

The No. 634BB Subscriber Set is an anti-sidetone common battery set with enclosed gongs, metal case finished in black. Intended for use in long subscriber loops, and P.B.X. extensions in either manual or dial systems. Consists of apparatus as shown below.

Code No.	Ringer	Gongs	Condenser	Induction Coil	Resistance	Retardation Coil
634BB	68JA	2-29C	1-149A 2-149B	62	63H	54S

LOCAL BATTERY SUBSCRIBER SETS

Anti-Sidetone—Continued

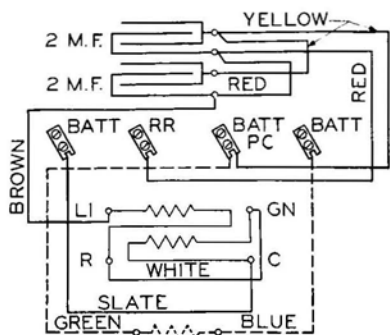

Wiring Diagram No. 634BD Subscriber Set

NO. 634BD SUBSCRIBER SET

The No. 634BD Subscriber Set is an anti-sidetone common battery desk set with enclosed gongs, metal case finished in black. Intended for use with 653BB Subscriber Sets, in long subscriber loops and P.B.X. extensions in either manual or dial systems. Consists of apparatus as shown below.

Code No.	Condenser	Induction Coil
634BD	2-147A	46

NO. 653BB SUBSCRIBER SET

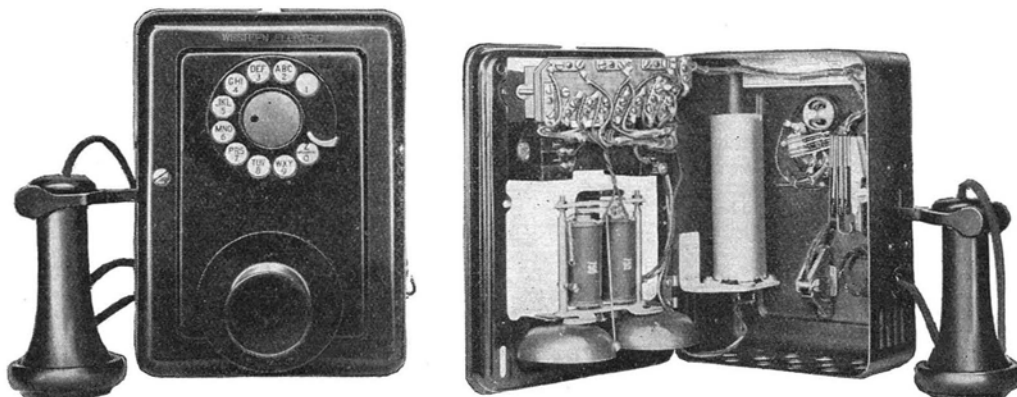

The No. 653BB Subscriber Set is an anti-sidetone common battery wall set with enclosed gongs, for use in long subscriber loops and P.B.X. extensions. It has a metal case finished in black. Intended for use in manual or dial systems. For dial service it uses a 4H type dial which is not furnished unless specified. When specified on the order this set will be furnished equipped with a 61D filter to suppress dialing induction in the radio receiving sets. For manual dialing it requires a 50B apparatus blank which is not furnished unless specified. Leads will be connected for manual service unless sets are ordered equipped with dials. A writing shelf can be provided with this set by using a 146A backboard. Consists of apparatus as shown below.

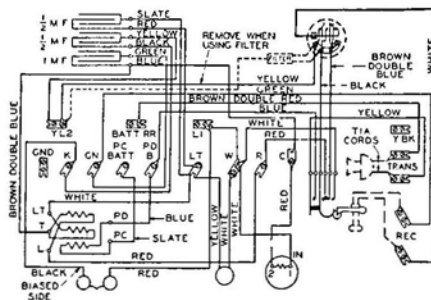

Wiring diagram No. 653BB Subscriber Set

Code No.	Ringer	Gongs	Con- denser	Induc- tion Coil	Switch- hook	Trans. Bracket	Cords	Resist- ance	Retard. Coil	Trans- mitter	Re- ceiver
653BB	68J	*2-29C	1-49A 1-49B	62	40AL	7A	2-T1A 9-7/8" long	63H	54S	+337	+567A

* Two No. 31C, 32C or 33C Gongs will be furnished in place of the 29C type when specified.

+ Not furnished with equipment. Must be ordered separately.

SUBSCRIBER SETS

Anti-Sidetone Type—Continued

NO. 684C SUBSCRIBER SET

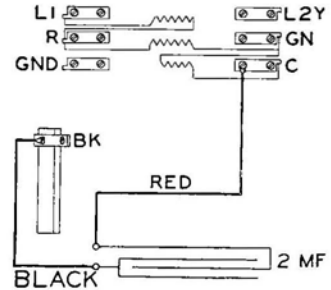
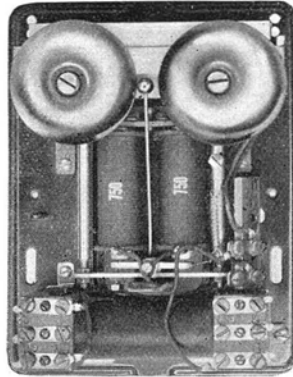
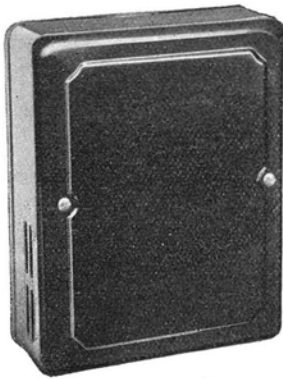

Wiring Diagram No. 684C

No. 684C—Closed and Open Views

The No. 684C Subscriber Set is a common battery desk type set without a ringer. Cover and base finished in black. Dimensions overall approximately $7\frac{1}{4}'' \times 5\frac{9}{16}'' \times 2\frac{5}{32}''$. Intended for use in either dial or manual service in anti-sidetone station equipment. Consists of apparatus as shown below.

Code No.	Condenser	Induction Coil	Remarks
684C	147A	101A or 146C	Replaces No. 584C

NO. 684BA SUBSCRIBER SET

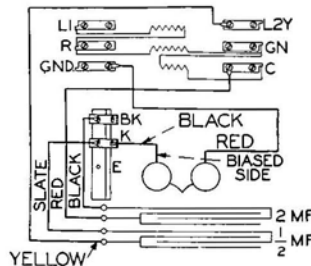

Wiring Diagram No. 684BA

The No. 684BA Subscriber Set is a small black finished anti-sidetone common battery desk type set with a metal base for mounting apparatus, and a removable molded cover. Intended for use in two-party selective or four-party semi-selective flat rate service in dial areas subject to inductive interference. Consists of apparatus as shown below.

Code No.	Ringer	Gongs	Condenser	Induction Coil	Remarks
684BA	78JA	*1-36A 1-37A	194B	146C	Replaces No. 534BA

* Two No. 36B, 36D, or one 39A Gongs will be furnished when specified.

SUBSCRIBER SETS
Anti-Sidetone Type—Continued

NO. 684BC SUBSCRIBER SET

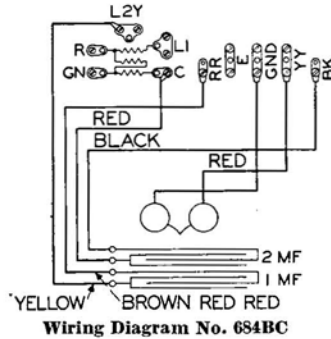

The No. 684BC Subscriber Set is a common battery desk type set (anti-sidetone) with enclosed gongs. Cover and base finished in black. Intended for use in either manual or dial service for two-party selective message rate service, developed for use in areas which are subject to inductive interference from power sources. Consists of apparatus as shown below.

Code No.	Ringer	Gongs	Condenser	Induction Coil	Remarks
684BC	78A	1-36A 1-37A	194A	101A	Replaces No. 554C and 584BC

No. 629A Subscriber Set

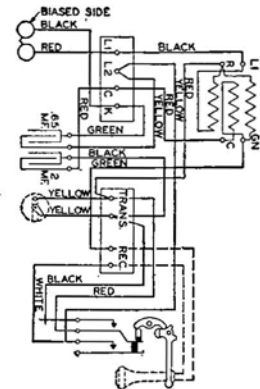
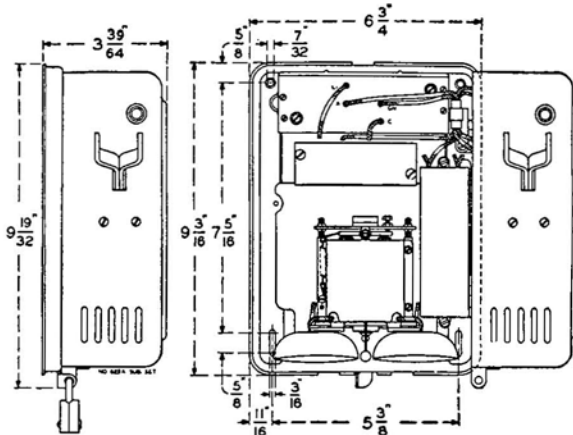

The No. 629A Subscriber Set is intended for use at locations where explosive gases might be present and accordingly embodies certain protective features. It is an anti-sidetone common battery wall type set having a black metal base and cover. It is furnished equipped with a padlock and all combinations are alike unless a special combination is specified.

The Set contains the following apparatus:

- | | |
|------------------|-----------------------|
| 1 68LD Ringer | 1 103A Induction Coil |
| 1 199A Condenser | 1 152A Switch Hook |
| 2 29D Gongs | |

The following apparatus is required but must be ordered separately:

- | | |
|---|-----------------------|
| 1 No. 337 Transmitter Unit | 1 P-213073 Mouthpiece |
| 1 No. 558 Receiver (includes R2AD Cord) | 4 P-204520 Screws |

SUBSCRIBER SETS—Continued

REPLACEMENT PARTS FOR NOS. 634-E, F, G, H, AR, BB AND BD SUBSCRIBER SETS

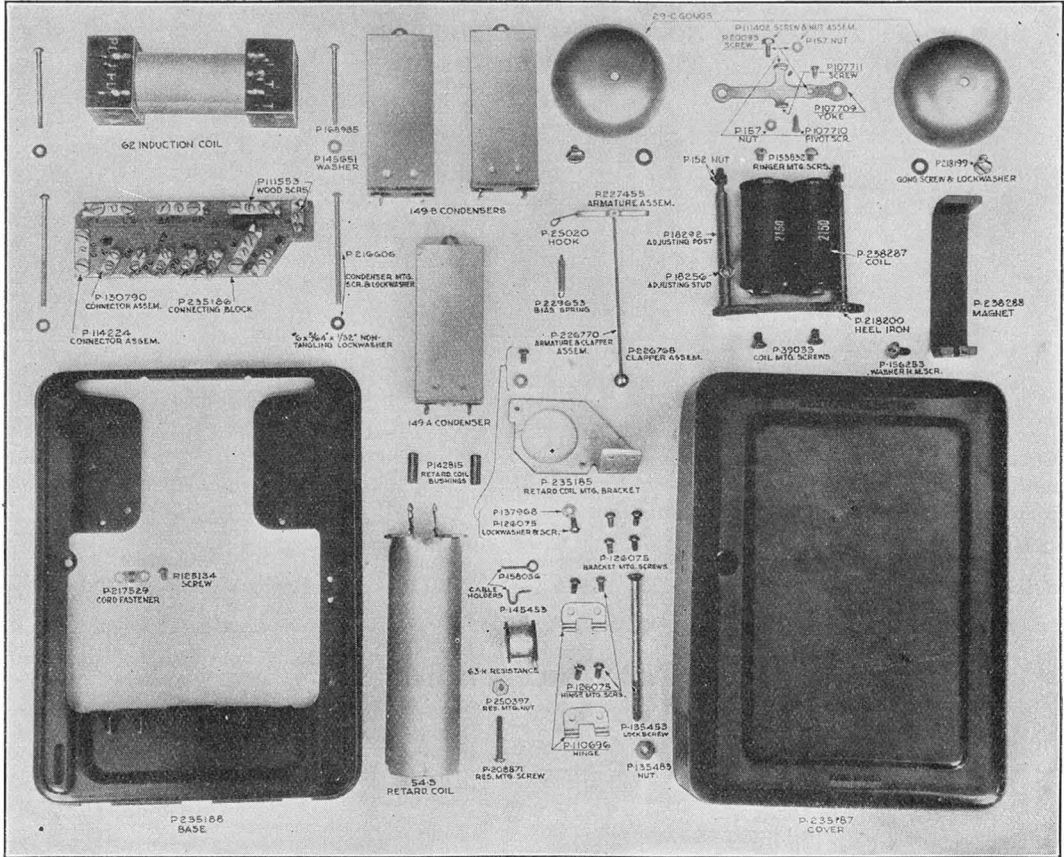

(Illustration shows parts for the 634-BB Subset)

Code No.	Piece Part or Apparatus
Note 1—Mounting screw for connector assemblies for:	
634-E, F, G, H, AR	P-238802
634-BD	P-111553
Note 2—Condenser mounting screw for:	
634-BD	P-204906
634-E, F, G, H, AR	P-135550
Note 3—Connecting block for:	
634-E, F, H, H, AR	P-236285
634-BD	P-235704
Note 4—The No. 29C Gong is regularly furnished for the 634-BB and AR subsets and 29-A for the 634-E, F, G, H subsets. If different tone gongs are required, the numbers 31-C, 32-C and 33-C gongs may be used for the 634-BB and AR subsets and 31-A, 32-A and 33-A gongs for the 634-E, F, G, H subsets.	
†Spacer for:	
634-E, F, G, H, AR	P-168123
†Circuit label for:	
634-BB	P-244517
634-E, F, G, H	P-244513
†Relay for:	
634-AR	85-N Relay
Note 5—Ringer for:	
634-E	41-S Ringer
634-F	41-T Ringer
634-G	41-U Ringer

Spare Parts for Ringers Used on the Nos. 634-E, F, G, H and AR Subscriber Sets

Note 1—Heel plate for:	
41-S, T, U, R (634-E, F, G, H)	P-109750
Note 2—Gong post for:	
41-S, T, U, R (634-E, F, G, H)	P-153016
Note 3—Magnet for:	
634-AR (72-A Ringer)	P-168854
41-S, T, U, R (634-E, F, G, H)	P-106993
Note 4—Yoke for:	
634-AR (72-A Ringer)	P-218369
Note 5—Coil for:	
634-AR (72-A Ringer)	P-235619 and P-243585
41-S (634-E)	P-133725
41-U (634-G)	P-132435
41-T (634-F)	P-214151
41-R (634-H)	P-214152
† Parts not shown in illustration.	

Code No.	Piece Part or Apparatus
Note 6—Condenser for:	
634-E, F, G, H 194-A Condenser	634-BD 147-A Condenser
634-AR	194-B Condenser
Note 7—Hinge and relay mounting screw for:	
634-AR	P-124482
† Parts not shown in illustration.	
Note 8—Ringer mounting screw for:	
634-E, F, G, H	P-217477
Note 9—Induction Coil mounting screw for:	
634-E, F, G, H, AR, BD	P-136734
Note 10—Cover for:	
634-E, F, G, H, AR, BD	P-166338
Note 11—Base for:	
634-E, F, G, H, AR	P-153830
634-BD	P-230431
Note 12—Connector assemblies for:	
634-BD	P-114224
634-E, F, G, H, AR	P-218870
Note 13—Induction coil for:	
634-E, F, G, H, AR	146-B Induction Coil
634-BD	46-B Induction Coil
† Mounting bracket for:	
634-BD	P-235705
† Mounting bracket screws for:	
634-BD	P-351132

Note 6—Clapper assembly for 41-S, T, U, R (634-E, F, G, H)	
See A-149011	
† For	Heel plate mounting screw P-43759
41-S, T, U, R	Pivot rivet P-106888
(634-E, F, G, H)	Eccentric screw P-106975
	Armature mounting nuts P-106992
	Core assembly P-158559
† Armature assembly for:	
41-T, U (634-F, G)	P-109792
41-S (634-E)	P-109794
41-R (634-H)	P-109793
Note 7—Ringer mounting screws for:	
41-S, T, U, R	P-166881
† Ringer spacer for: 41-S, T, U, R	P-108230
† Terminal screw for: 41-S, T, U, R	P-203971

SUBSCRIBER SETS—Continued

REPLACEMENT PARTS FOR NOS. 684-C AND BA SUBSCRIBER SETS

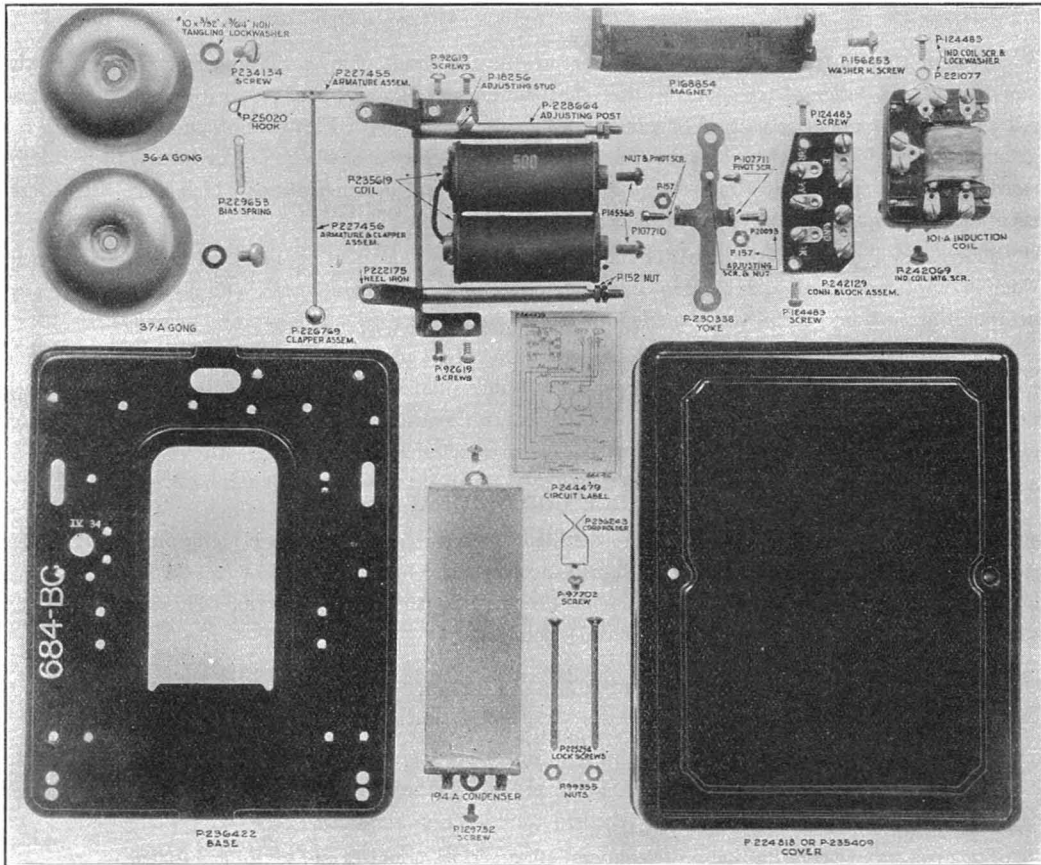

(Illustration shows parts for 684-BC Subset)

Code No.	Piece Part or Apparatus
Note 1—Condenser for:	
684-BA	194-B Condenser
684-C	147-A Condenser
Note 2—Cord holder for:	
684-BA	P-222194
Note 3—Cord holder mounting screw for:	
684-BA	P-129732
Note 4—Induction coil for:	
684-BA, C	146-C Induction Coil
Note 5—Ringer for:	
684-BA	78-JA Ringer
Note 6—Condenser Mounting Screw for:	
684-C	P-166781
†Condenser strap for:	
684-C	P-225255
Note 7—Connecting block for:	
684-C, BA	P-236421

Code No.	Piece Part or Apparatus
Note 8—Connecting block mounting screws for:	
684-C, BA	P-111553
Note 9—Base for:	
684-C, BA	P-242205
Note 10—Circuit label for:	
684-C	P-244467
684-BA	P-244757
†Terminal for:	
684-BA, C	P-231008
†Mounting screws for terminal:	
684-BA, C	P-111553
Note 11—The Nos. 36-A and 37-A Gongs are regularly furnished. If different sound gongs are required the 36-B, 36-D and 36-A gongs may be used.	
†Parts not shown in illustration.	

Spare Parts for Ringers Used on the 684-BA Subscriber Set

Note 1—Coil for:	
78-JA Ringer	P-238287
Note 2—Yoke for:	
78-JA Ringer	P-107709

Note 3—Magnet for:	
78-JA Ringer	P-238288

SWITCHBOARDS**Telephone Switchboards and Systems**

Western Electric telephone switchboards represent the result of over fifty years experience in the manufacture and design of telephone central office equipment. By virtue of its position as the largest as well as the oldest manufacturer of telephone equipment, the Western Electric Company has been a big factor in the development of the telephone art to its present degree of perfection. As a result their switchboard equipment incorporates material, apparatus, circuits and design features which have been found essential for the successful operation of modern telephone systems.

These switchboards are the result of continuous efforts by this great organization to build equipment which is simple in operation, durable in construction, economical in maintenance, and highest in efficiency, incorporating such new features as experience suggests and modern telephone practice demands.

The smaller switchboards are fully described and will be found adequate to meet the requirement of every non-multiple central office. The larger central offices must of necessity be designed to care for the individual requirements of each exchange area. Western Electric engineers are equipped to make studies and recommend correct central office equipments for any part of the world.

AUDIBLE CODE SIGNALING

To enable the switchboard operator to distinguish various code rings on bridging lines an "audible code signaling" feature can be provided. This is accomplished by using No. 6 or No. 26 Type Combined Jacks and Signals, having a local contact which is closed during the ringing interval. This contact operates a local alarm bell circuit, which repeats the codes sounded.

CENTRAL OFFICE SELECTIVE SIGNALING

This signifies that the subscriber can signal the central office without ringing the other bells on a rural line, or signal the other parties on the line without operating the switchboard signal. For this service the No. 7 or No. 27 Type Combined Jacks and Signals are used, permitting one side of the signal winding to be connected to ground. Push button type telephones are used on these lines.

For diagram and information on telephones, see descriptive matter under "Magneto Telephone" sets.

COMBINED JACK AND SIGNAL

This is the term given to the Western Electric line signal where the jack is mounted immediately under its associated signal. These signals are automatically restored when the answering plug is inserted.

CORD CIRCUIT, COMBINATION

This type of cord circuit is so designed that one cord of the pair may be used on either central battery or magneto lines, the other cord being used for one class of service only. The latter may be either central battery or magneto, depending upon the class of service involved.

CORD CIRCUIT, UNIVERSAL

This type of cord circuit is so designed that each of the two connecting cords is adapted for making connections with either magneto or central battery lines. The circuit automatically adapts itself to either class of service by the operation of relays which form a part of the circuit. The circuit may be used for connecting two magneto lines and two central battery lines or one magneto line and one central battery line.

CORD CIRCUIT, JACK LISTENING TYPE

In this type of cord circuit the operator can listen in on a line by inserting the plug of the listening cord into a listening jack. One of these listening jacks is associated with each pair of connecting cords. Plugging in the listening cord bridges the operator's telephone set across the line.

SWITCHBOARDS**Telephone Switchboards and Systems**

(Continued)

CORD CIRCUIT, KEY LISTENING TYPE

In this type of cord circuit the operator can listen in on a line by merely operating the listening key handle of a cord circuit key. One of the keys is associated with each pair of cords and the corresponding supervisory drop.

CORD CIRCUIT, NON-HANG-UP TYPE

In this type of cord circuit it is possible under all conditions for both subscribers, at the completion of a conversation, to operate the clearing-out signal on the operator's cord circuits.

CORD CIRCUIT, NON-RING-THROUGH TYPE

This type of cord circuit is so equipped that it is impossible for any subscriber in "ringing-off" to ring any of the bells on the connected line.

CORD CIRCUIT, NON-HANG-UP NON-RING-THROUGH TYPE

This type of cord circuit includes the features of the non-hang-up and the non-ring-through circuits.

LINES WITH LINE RELAYS

In central battery private exchanges and private branch exchange switchboards, it is necessary to use line relays in order to operate lines that have over 30 ohms resistance. This corresponds approximately to an 800 foot line of No. 22 or a 1600 foot line of No. 19 B. & S. gauge copper wire.

REPEATING COILS IN MAGNETO SWITCHBOARDS

These are sometimes used at the switchboard end of a grounded circuit to eliminate noise when connecting metallic circuits. They are also used in cord circuits to provide the "non-hang-up, non-ring-through" feature. Repeating coils are also used in connection with cord circuits to correct noisy or unbalanced lines.

RINGERS USED AS SWITCHBOARD LINE SIGNALS

Ringers are slightly more sensitive than drops or signals, and are sometimes used on extremely long lines. They are also used sometimes where audible code signaling is desired. The Western Electric audible code signaling drop provides this feature without the sacrifice of the additional space required in which to mount ringers.

RINGER INDICATORS

These are provided on the ringers used in place of signals or drops where the operator is not constantly at the switchboard. They indicate which line has been calling by means of a sliding shutter actuated by the motion of the clapper.

RINGING, ONE WAY

This provides for ringing on the calling (front or nearest the operator) cords only.

RINGING, TWO WAY

This provides for ringing on the calling (front or nearest the operator) and also upon the answering (back or farthest from the operator) cords.

RINGING KEYS, INDIVIDUAL, FOR PARTY LINES

In this case the various parties on the party line can be signaled selectively by means of the cord circuit key associated with each cord circuit.

RINGING KEYS, MASTER, FOR PARTY LINES

In this case, the various parties on the party line can be signaled selectively, only when a master ringing key is operated in conjunction with a cord circuit key. There is one master key for each operator's position.

SWITCHBOARDS**Telephone Switchboards and Systems**

(Continued)

RINGING COMBINATIONS

For further information on classes of ringing service see preceding pages of telephone terms.

Single party, one-way or two-way ringing provides for ringing one telephone only over the calling cord or over the calling or answering cord, respectively.

Two-party, one-way, selective individual or selective master key (divided circuit) provides for ringing one of two parties on the same line selectively over the calling cord only.

Two-party, two-way, selective individual or selective master key (divided circuit) provides for ringing one of two parties on the same line selectively over either calling or answering cord.

Four-party, one-way, pulsating individual or pulsating master key provides for signaling one of four parties on the same line selectively, over the calling cord only, by means of positive or negative pulsating current over either side of the line to ground.

Four-party, two-way, pulsating individual or pulsating master key provides the same service as the preceding combination except that ringing current can be sent out over either calling or answering cord.

Four-party, two-way, harmonic individual or harmonic master key provides for the same service as the preceding combination except that ringing current can be sent out over either calling or answering cord.

Eight-party, one-way, harmonic individual or harmonic master key provides for the same service as the corresponding four-party combination except that any one of the eight parties on the same line can be signaled selectively over the calling cord only.

Eight-party, two-way, harmonic master key provides for the same service as the corresponding eight-party combination except that any one of the eight parties on the same line can be signaled selectively over either calling or answering cord.

SUPERVISORY SIGNAL, MAGNETO

This signal, also known as a clearing-out drop, consists of a drop bridged across each cord circuit to indicate when a conversation has been completed. The current for operating this drop is furnished by the ring-off signal from the subscriber's telephone set generator.

SUPERVISORY SIGNAL, CENTRAL BATTERY

This consists of a lamp associated with each cord of the cord circuit. This lamp lights when a conversation is completed and the subscriber hangs up his receiver. It remains lighted until the connection is taken down. When making a connection, the lamp on the calling cord remains lighted until the called-for subscriber answers.

SUPERVISION, SINGLE

This term is used to describe a telephone switchboard cord circuit having only one "clearing-out" or "ring-off" drop.

SUPERVISION, DOUBLE

This term is used to describe a cord circuit having two "clearing-out" or "ring-off" drops or two supervisory lamps, one per cord. (For diagrams see description of No. 1200 Type Switchboards.)

THROUGH TOLL LINES

These toll lines are those that loop through an intermediate office. For example, when a toll line connects A and C, and passes through an intermediate office B, code signaling is employed. A and C are called with one ring, and B with two rings.

By means of "cutoff" jacks at B, the one line is made to act as three. That is, either as a through circuit between A and C, or as two local circuits; one between A and B and the second between C and B.

TRANSFER CIRCUITS

These are used where a switchboard consists of two or more positions and a number of the subscriber line jacks are out of the reach of any one operator. The transfer circuits provide a means of extending the cord circuits to the positions in which the jacks appear.

TRUNK, RECORDING TOLL

This is a trunk circuit between the local switchboard and the toll switchboard that makes it possible for subscribers desiring toll connections to get in direct communication with the recording toll operator. When it is known that it will take some time to complete the toll call, the operator tells the subscriber to hang up and can then call him back to the line over the trunk.

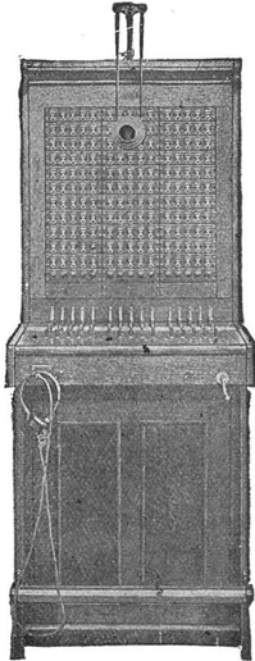
SWITCHBOARDS—MAGNETO NON-MULTIPLE

Front View

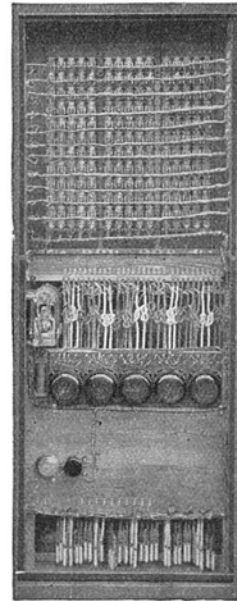

Rear View

No. 1240D Switchboard

CAPACITY 165 LINES 15 CORD CIRCUITS

This standard efficient magneto switchboard has been giving universal satisfaction in all parts of the United States and foreign countries. Designed by the largest corps of telephone engineers in the world and equipped with reliable, efficient apparatus, it has met with the approval of operating companies requiring magneto switchboards that insure a long life of service, coupled with economical operating and maintenance.

Where more than 165 lines are required several sections may be lined up with good results. This has been done in numerous cases and the desired capacity obtained without any complications. All of the apparatus used in this switchboard has been proven reliable and efficient in operation by many years of service, it being economical to maintain and exempt from repairs to an exceptional degree.

The operation of the No. 1240D Switchboard is simple and easily performed, for the line jacks are so grouped as to be within easy reach of the operator, reducing that work to a minimum.

THE FRAMEWORK

The lumber used in the construction of the cabinet is red oak, thoroughly seasoned and kiln dried to prevent warping or cracking. All joints in the woodwork are tongued and grooved and securely fastened with the best quality of glue, no butt joints being used. Steel angles are installed inside of the cabinet at the corners giving additional strength to the cabinet.

The exterior of the cabinet is given a dull golden oak finish which is very serviceable. As an added precaution against warping, cracking or decay the interior surfaces are coated with shellac.

The steel framework which supports the face equipment is copper plated as a protection against corrosion or rust, also insuring a positive ground connection for the apparatus. This framework is fastened to the cabinet in a secure manner which insures a permanent, rigid support for the drops and jacks in the face of the board. The front panel and the rear door are removable, which permits easy access to all of the equipment.

The keyshelf is twenty-four (24) inches wide allowing ample space for the operator. The keys are mounted upon cold drawn galvanized steel bars, which are supported at either end by steel reinforcing details and fastened to these bars with machine screws. Thus a perfect, rigid alignment is obtained for the keyboard equipment as the machine screws do not loosen by the operation of the keys.

SWITCHBOARDS—MAGNETO NON-MULTIPLE**No. 1240D Switchboard—Continued**

The cordshelf, upon which the cord terminals are mounted, is located where inspection or repairs can be made conveniently. All terminals are plainly marked.

An apparatus and terminal board is mounted in the rear of the switchboard on which are mounted the repeating coils, night alarm bell, and large screw terminals where all power wiring such as power ringing, transmitter battery, night alarm battery, monitor tops, etc., are terminated.

THE LINE CIRCUITS

The line circuits are equipped with the efficient No. 22C Combined Jack and Signal mounted five per strip, consisting of the well known shutter type drop and cut-off jack which have been standard equipment on Western Electric magneto switchboards for many years. The drops are self-restoring upon insertion of the plug in the jack, positive in action and will not stick. Removable number plates with large characters are mounted on the shutters of the drops. The night alarm springs are insulated from the jack springs and the design insures reliable operation of the night alarm circuit.

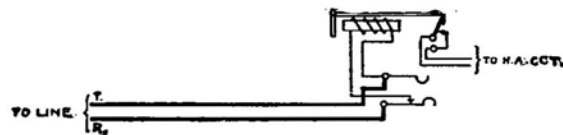

Line Circuit No. 1240-D Switchboard

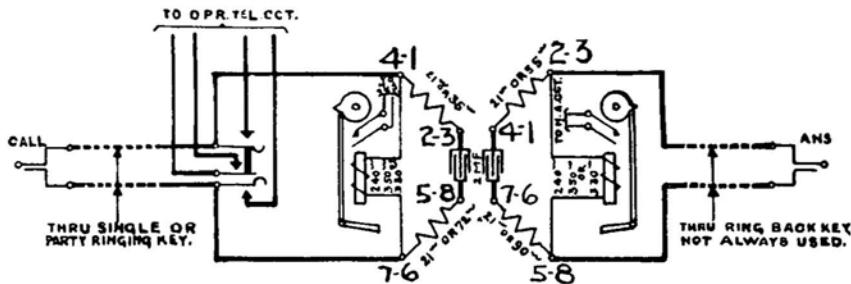
Non-Ring Through Non-Hang Up Double Supervision Cord Circuit
No. 1240 Switchboard**THE CORD CIRCUITS**

The local cable in this switchboard is so arranged that any of the various standard type of cord circuits may be equipped as follows:

Single supervision, without repeating coil.

Single supervision, with repeating coil and cutout key (cords Nos. 1 to 5).

Double supervision, "non-ring through," "non-hang-up" with repeating coil.

Double supervision, practically "non-ring through," "non-hang-up" without repeating coil.

The supervisory (ring off) signals are of the manually restored shutter type drops equipped with number plates having large characters easily distinguishable by the operator. The cords are installed in accordance with the standard distinctive color scheme, each pair alternating red, white and green in the order named. This is a great help to the operator in locating cord pairs to take down connection corresponding to the "ring off" drop which has been operated, also reducing the possibility of error to a minimum.

The keys are of the type and design that have been giving service for years in the largest switchboards. They are so arranged that the springs are easily accessible for inspection when the keyshelf is open. These springs are constructed of metal having the proper resiliency which will insure good contact both in the normal and operated positions. They are positive in action and designed for long life service.

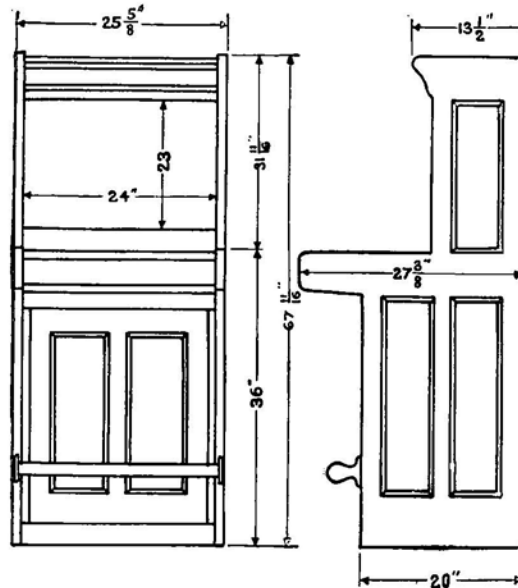
SWITCHBOARDS—MAGNETO NON-MULTIPLE

Dimensions No. 1240-D Switchboard

No. 1240D Switchboard—Continued**OTHER CIRCUITS**

The ringing circuit is equipped with a powerful five bar hand generator. The local wiring is universal in that any of the following ringing combinations may be equipped as required:

Single party, two way	Four party, two way, pulsating master key
Two party, one way selective, individual key	Four party, one way, harmonic, individual key
Two party, two way, master key	Four party, two way, harmonic, master key
Four party, one way, pulsating, individual key	Eight party, two way, harmonic, master key.

The operator's telephone circuit is furnished with the standard receiver and transmitter known the world over for their high transmission efficiency. Ordinarily the suspended type transmitter is used, although the chest type instrument can be used if desired as the wiring is in place for either type.

The night alarm circuit is equipped with a reliable loud ringing vibrating bell operated with dry batteries and a night alarm key for cutting the bell off or on as required. This key, together with the operator's telephone jacks and ringing generator crank, are located conveniently in the front of the keyshelf rail.

All of the following features are provided for and may be included without difficulty either before or after the switchboard is placed in service:

Audible code ringing on subscribers	Buzzer equipment in positional ringing circuit (single or two-party)
Through toll lines	Telephone switching key for connecting two positions together
Monitoring or transmitter cut-out	Plug ended switching trunks from toll switchboard operator
Call wire circuits	
Duplicate set of operator telephone jacks for student operator	
Jack ended interposition trunks with lamp signal	

Battery current for the operator's telephone circuit is supplied from three dry cells or five Edison primary batteries and for the night alarm circuit from five dry cells or eight Edison primary batteries.

CABLE

The standard method of running the line cables is through the top of the switchboard, which is the best method, since the cables are kept off of the floor away from moisture or mechanical injury. However, if local conditions are such that it is advisable to bring the line cables in at the bottom of the section they will be furnished accordingly.

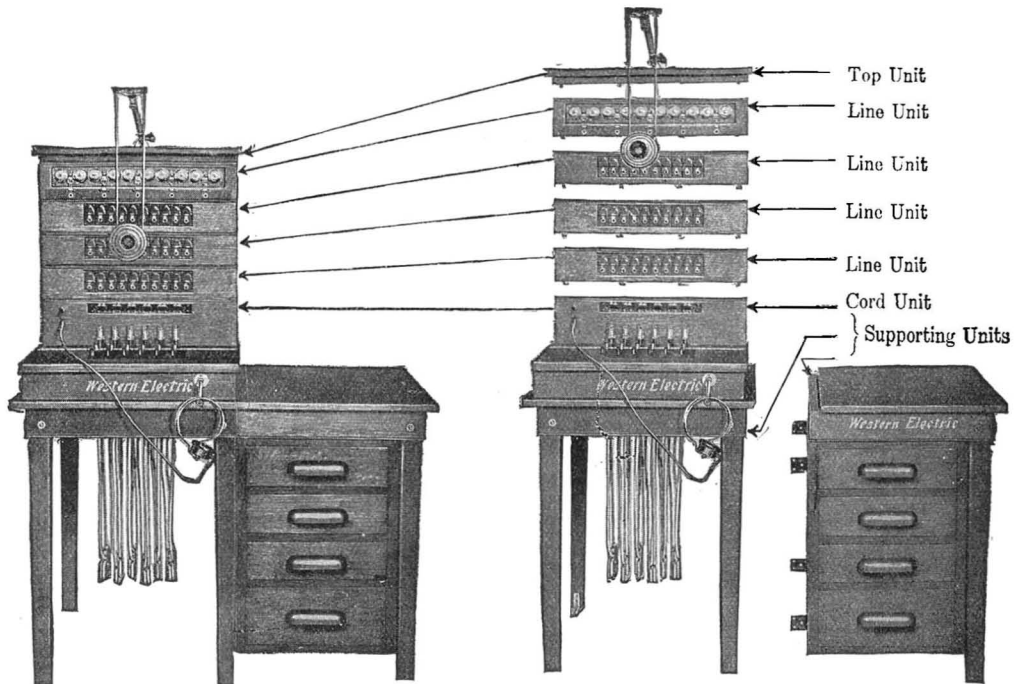
SWITCHBOARDS—MAGNETO NON-MULTIPLE

Method of assembling No. 1800 Switchboard to 35 line capacity

No. 1800 Sectional Unit Type Switchboard

The unit or sectional type construction for the small switchboard was introduced by the Western Electric Company a number of years ago, and since that time has been supplying the demand of discriminating buyers for a small switchboard that would meet their traffic requirements and eliminate the necessity of buying an "oversize switchboard."

The capacity of the No. 1800 Unit Type Switchboard is from 10 to 50 lines. While 50 lines has been set as an arbitrary maximum it is safe to assume that with a normally low calling rate as many as 70 or 80 lines can be handled conveniently. While the No. 1800 Unit Type Switchboard is small in size (floor space required only 2 feet x 2½ feet), this does not mean that this board receives less consideration or care in manufacture than a larger switchboard, for the same quality of material, skilled workmanship and rigid inspection are applied to all of the Western Electric products regardless of size. Red oak lumber, which has been kiln-dried, thoroughly seasoned and given a dark rubbed finish, is used in the construction of the units. The inside of the units have been specially treated to preserve wood and prevent warping or cracking.

To meet various requirements, there are different types of base or supporting units, cord units, line units and top units. To assemble a switchboard of 10 lines capacity for example it is only necessary to select units as follows:

1 Supporting Unit	1 Line Unit
1 Cord Unit	1 Top Unit

These units are easily assembled into a complete switchboard which presents a neat, compact and serviceable appearance and can be arranged to meet any service condition. Line units can be added at any time.

All of the apparatus and terminals associated with the operator's cord and telephone circuits are mounted in the cord unit.

The circuits used are very simple. A diagram of each circuit is pasted to the inside of the rear doors for convenient reference. The back of each unit is hinged and when open, all of the wiring and equipment are easily accessible.

The switchboard is especially recommended for small, rapidly growing telephone exchanges where the ultimate capacity cannot be definitely determined.

SWITCHBOARDS—MAGNETO NON-MULTIPLE**No. 1800 Sectional Unit Type Switchboard—Continued****No. D-3 Supporting Unit****No. D-4 Supporting Unit****SUPPORTING UNITS**

The Nos. D-1 and D-2 Supporting Units are special heavy brackets for use in mounting the No. 1800 Type Switchboard in a convenient location on the wall. These brackets mount on a one inch polished red oak board which is fastened securely to the wall before the brackets are attached. One bracket in each of the Nos. D-1 and D-2 types is hinged to permit the swinging of the switchboard to a position at a right angle with the wall upon which it is mounted which makes the apparatus easily accessible. The No. D-1 Unit has the hinged bracket at the right and the No. D-2 Unit at the left.

The No. D-3 Supporting Unit. Consists of a rigid skeleton table upon which the cord line units can be mounted.

The No. D-4 Supporting Unit. Consists of a tier of drawers designed for mounting next to the skeleton table unit No. D-3. The combination of the two units (Nos. D-3 & D-4) makes a very neat, compact, complete and sanitary switchboard support.

The No. D-5 Supporting Unit. Is an extension writing panel which is always required in connection with cord units Nos. CA-1, CB-1, and CA-5 when mounted on supporting unit No. D-3. This is necessary since the cord circuits in the Nos. CA-1, CB-1 and CA-5 Units are not equipped with keys and the keyshelf is not as wide as the units in which keys are used in the cord circuits.

THE LINE UNITS

The line units are made in different types arranged to meet any possible line condition. Copper bars are used for mounting the combined drops and jacks in the face of the unit, and special drilled steel mounting plates for the ringer indicators, which insure perfect rigid alignment for the face equipment. The corners of the unit are neatly mortised together and reinforced on the inside with substantial steel brackets. The finished unit presents a very neat, compact and serviceable appearance.

The following units are equipped with ringers (bells) and jacks. The bells are equipped with an indicator which shows which bell has rung. A very convenient arrangement where the operator is not always at the switchboard.

Code No. of Unit	Code No. of Ringer	Resistance of Ringer in Ohms	Code No. of Jacks
BA-7	40BG	2500	168
BB-7	40FG	1600	168
BC-7	40AG	1000	168

The following units are equipped with self-restoring shutter type combined jacks and signals.

Code No. of Unit	Code No. Combined Jack and Signal	Resistance in Ohms
BA-12	22C	330
BA-13	26C	330

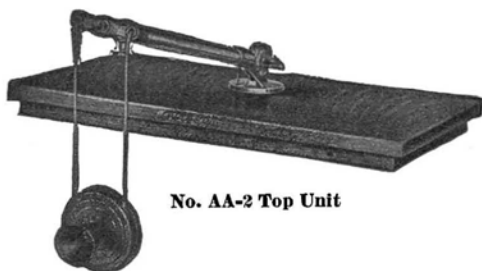
SWITCHBOARDS—MAGNETO NON-MULTIPLE

No. AA-2 Top Unit



No. AA-1 Top Unit

No. 1800 Sectional Unit Type—Continued

These units are made in two types to meet the various conditions described below:

The No. AA-1 Unit is merely a "cover" for the line units and is intended for use when the cord circuits are arranged for a handset or desk set.

The No. AA-2 Unit is similar to the No. AA-1 except that it is arranged for use with a suspended type transmitter. A No. 232-W Transmitter and No. 19-D Transmitter Arm are furnished with this unit.

THE CORD UNITS

These units are made up in different types to meet the operating requirements of any small magneto exchange.

The cord and operator's telephone circuit apparatus is all mounted in the cord unit. All connections to the line units are made under screw terminals and the only tool required for this work is a screw driver. The keyshelf is hinged and all terminals are accessible. The rear doors of the cord and line units are hinged, and when opened all of the wiring and apparatus is easily accessible. The circuits used are simple and a diagram of the circuit is pasted on the inside of the rear door of each unit.

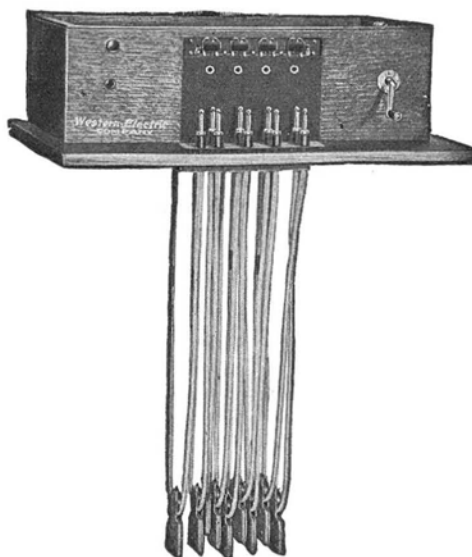

No. CA-1 Cord Unit. This unit is equipped with 4 cord circuits arranged with ring off drops and listening jacks, the two left-hand circuits being wired for repeating coils which may be easily added if desired.

The operation of this unit is as nearly "fool-proof" as it is possible to make a switchboard. The 4 cord circuits can each be considered as being the same as a single length of cord with a plug on both ends and no other connection with the switchboard except the "ring off drop" and the "listening in jack" which are "bridged" across the line. The ring off drop operates when the subscribers have completed their conversation and "ring off." The "listening in jack" provides means for the operator to supervise the connections.

SWITCHBOARDS—MAGNETO NON-MULTIPLE**No. 1800 Sectional Unit Type—Continued**

The operator's telephone set consists of a hand telephone set having the transmitter and receiver connected together as one unit.

The additional single cord at the left is the operator's talking, ringing and listening cord. With this cord the operator answers the calling party, finds out who is to be called and rings them. The connection is then established with any one of the other cord circuits and left up until the ring off drop operates. Interference with a connection, after it is once established, is reduced to a minimum.

No. CB-1 Cord Unit. This unit is the same as the CA-1 Unit except that the operator's telephone circuit is arranged for a suspended type transmitter.

The No. CA-2 Unit is equipped with four cord circuits, the two left-hand cords of which are wired for repeating coils (repeating coils are not furnished unless specified) and is the same as the CA-1 Unit except that No. 156-A Two Lever Key is used in the cord circuit for ringing, listening and talking and is wired for ringing on both the front and rear cords. This unit is equipped with a suspended transmitter.

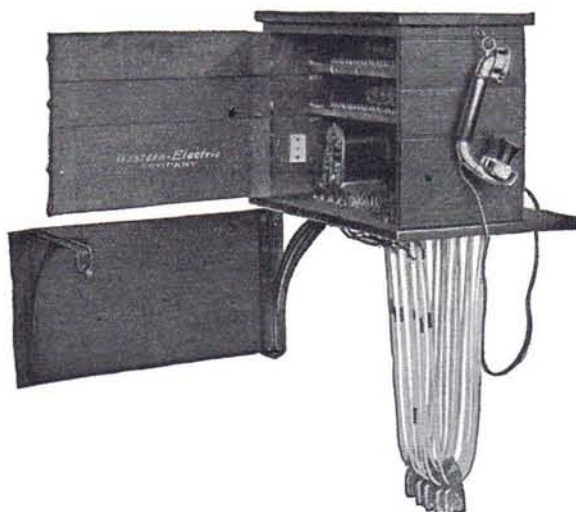

Rear View of 20-line Wall Type No. 1800 Switchboard

The No. CB-2 Unit is the same as the No. CA-2 except that it is arranged for the use of a handset or a desk telephone in operator's telephone circuit.

The No. CA-6 Unit is the same as the No. CA-2 Unit except that it is arranged for six cord circuits instead of four, and is provided with a suspended transmitter.

The No. CB-6 Unit is the same as the No. CA-6 except the telephone circuit is arranged for use with hand set or desk telephone.

The units assembled into a wall type switchboard present a very neat and compact appearance. All of the wiring, terminals and apparatus are easily accessible when the switchboard is swung out and the rear doors opened for inspection. A convenient switchboard for use when the central office is located in a residence.

SWITCHBOARDS—MAGNETO NON-MULTIPLE

No. 1800 Sectional Unit Type—Continued

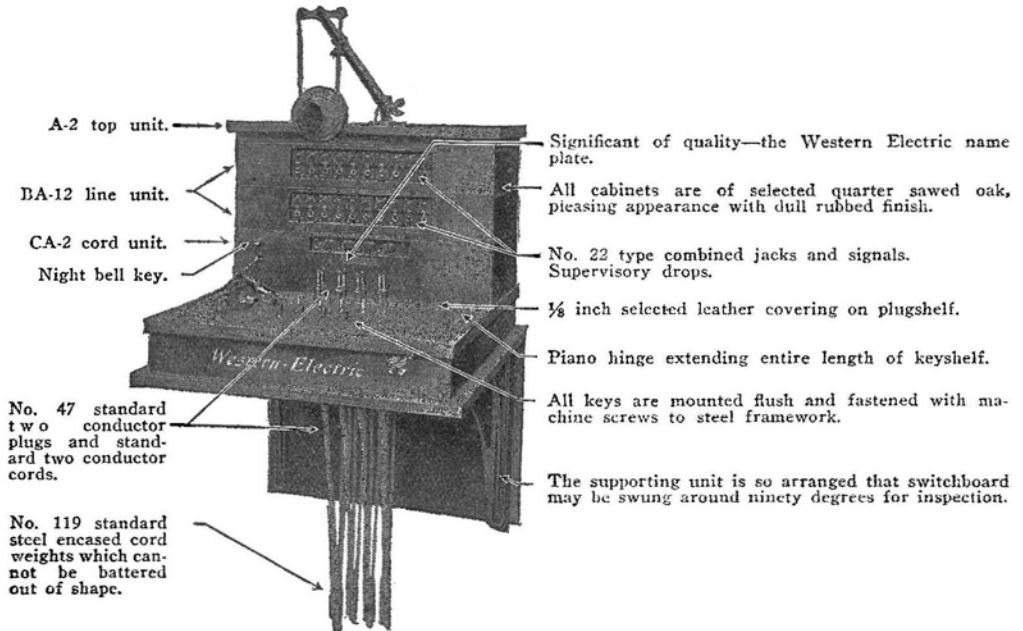

No. 1800 Sectional Switchboard

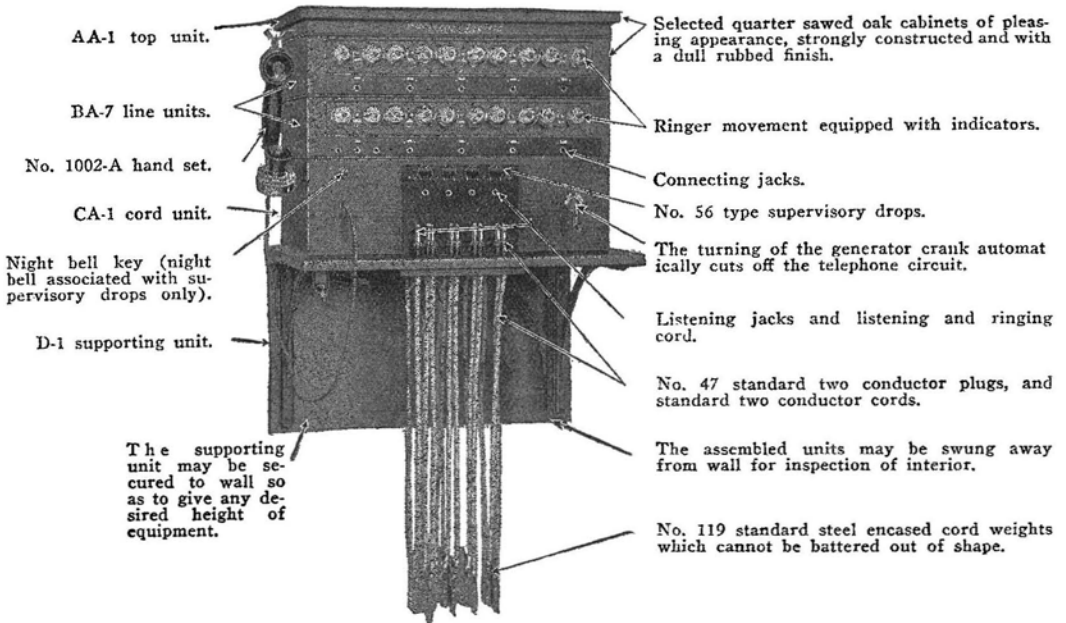

No. 1800 Sectional Switchboard

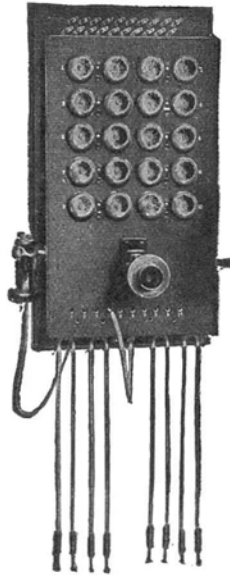
**SWITCHBOARDS—MAGNETO NON-MULTIPLE
WALL****No. 1012 Switchboard****No. 1012 “Ringer Type”**

This switchboard is intended for use on exchanges having 10 lines or less, and where the number of calls does not warrant having a regular telephone operator in attendance. It has been installed by numerous rural companies who desire a switching station established in the country in which cases it is installed in a farmer's home and the calls are answered by members of the family. Being equipped with ringers, constant attendance at the switchboard is not necessary as the bells can be heard at some distance from the board. In addition to this ringer indicators are supplied with each ringer which gives a visible signal showing which bell has been ringing.

The cabinet is well constructed of thoroughly seasoned, quarter sawed oak, which is given a durable light finish. The front is hinged and the apparatus and wiring is within easy reach for inspection or maintenance.

Equipment. Each line is provided with a jack and a 1000 ohm ringer, although 1600 or 2500 ohm ringers can be furnished if required. Four-cord circuits, with a listening in jack bridged across the tip and ring, and a listening cord are provided for handling the calls, no supervisory or ring off signals being provided. A powerful five-bar hand generator is furnished for ringing purposes. The operator's telephone set consists of the regular long distance transmitter and receiver.

Operation. Subscribers are called by ringing with the hand generator over the listening cord with which the operator answers calls and listens in for supervisory purposes. Connections are made with the other cords, without the use of keys.

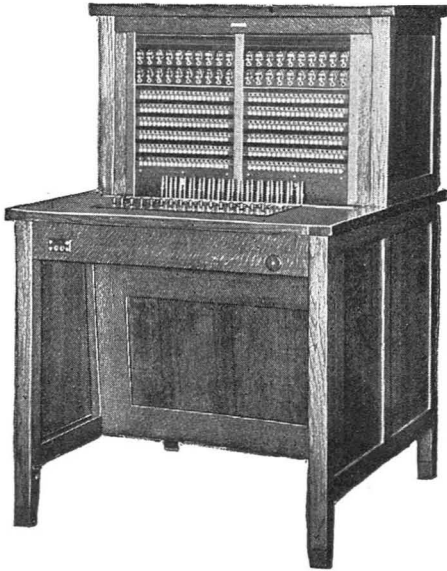
SWITCHBOARDS—CENTRAL BATTERY**Non-Multiple****No. 1948 "Sanitary Type" Switchboard**

Capacity

240 Central Battery Lines

40 Toll or Rural Lines

20 Transfer Trunks

No. 1948 "Sanitary Type"

The No. 1948 Switchboard is designed to provide the small telephone companies who desire central battery service with modern efficient and reliable equipment. It is built along the lines of the modern office desk, having square lines generally, square legs (metal capped at bottom) and a clearance underneath for cleaning purposes, hence the term "Sanitary Type" and is the Western Electric Company's latest departure from old methods of small switchboard manufacture. Meeting the demands of exacting buyers as it does is evidence of the confidence enjoyed by this company in the development of a much needed small central battery switchboard which is easy to operate, economical to maintain and constructed of the same materials which enter into the construction of the larger boards upon which the Western Electric Company's reputation for quality products is built and maintained.

The Framework. The cabinet is constructed of durable red oak lumber, which has been kiln dried and thoroughly seasoned to prevent warping and cracking and provided with a dull rubbed dark finish. Each section is a unit by itself, although several sections can be lined up together as the end panels are removable. The keyshelf is a convenient height (30 inches) allowing the use of an ordinary chair for the operator.

The equipment, relays, resistances, retard coils, etc., associated with the various circuits are mounted on a swinging relay gate presenting a neat, compact appearance when closed and bringing the apparatus and wiring within easy reach when open.

SWITCHBOARDS—CENTRAL BATTERY
Non-Multiple
No. 1948 Sanitary Type—Continued

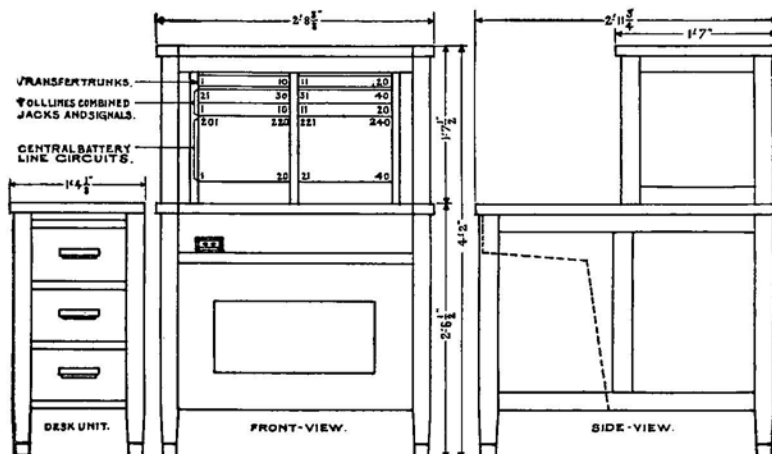
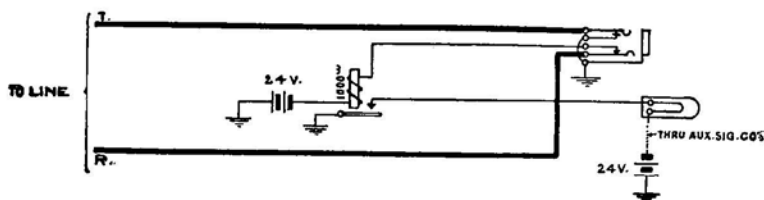

DIAGRAM SHOWING DIMENSIONS OF NO. 1948 SWITCHBOARD.

The Line Circuits. The line circuits are as simple as is consistent with modern practice. They are equipped with flat type relays which require a small mounting space and are especially adapted for use in a self-contained switchboard of this type. These relays consume a comparatively small amount of current resulting in economy in storage battery equipment.



LINE CIRCUIT 1948 SWITCHBOARD.

The Cord Circuits. The local cables which contain all of the wiring inside of the switchboard are universally wired, and can be equipped to include any of the features listed below:—

- (a) Subscribers central battery cord circuits.
- (b) Rural universal, with or without repeating coils and cutout keys. Repeating coils and cutout keys not equipped unless specified. Cutout keys are used for cutting the repeating coil in or out of the cord circuit as required.
- (c) Ringing combination for either central battery or universal cord circuit.
 - Single party, two-way.
 - Two party, two-way, master key.
 - Four party, two-way, master key (pulsating).
 - Four party, two-way, master key (harmonic).
 - Eight party, two-way, master key (harmonic).

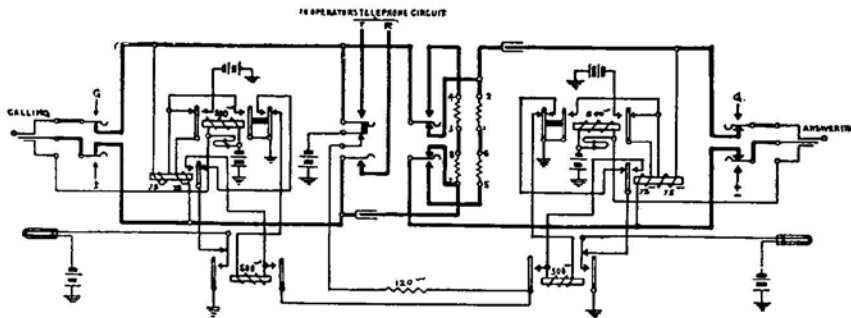
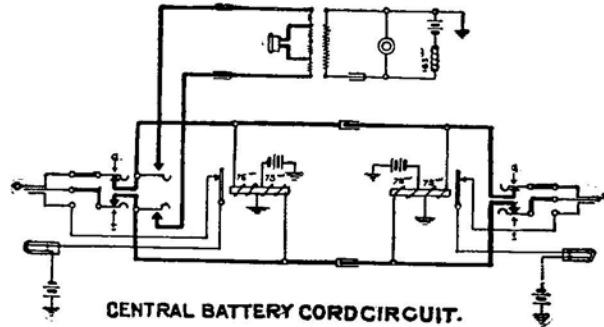
SWITCHBOARDS—CENTRAL BATTERY**Non-Multiple****No. 1948 Sanitary Type—Continued**

UNIVERSAL CORD CIRCUIT WITH REPEATING COIL AND CUT OUT KEY.

Power Plant. The proper battery supply for this switchboard is obtained from storage batteries. Since the storage battery is a very important part of the telephone system and the satisfactory operation depends upon a reliable battery supply, it is imperative that great care be exercised in the selection of this unit. In figuring the size of the charging machine and storage battery consideration should be given to the source of power supply with regard to its reliability. In ordinary cases provide not less than 36 hours reserve and up to 72 hours in cases of questionable power.

The size of batteries may be determined on the basis of the following example of calculation:

1000 total local and rural connections per 24-hour day.
 .015 current in ampere hours per call (based on call of ordinary duration).

5000	
1000	
15,000	

15,000 current in ampere hours for calls in 24 hours.

Since the rating of the storage battery is computed on an 8-hour capacity it is necessary to divide the ampere hour rating for 24 hours by 3 hours in order to determine the ampere rating of the battery required.

Thus	15,000 current in ampere hours for calls in 24 hours divided by 3-hour capacity
Equals	1.875 ampere = ampere rating for battery 24 hours
Plus	.1875 10% safety factor
Equals	2.0625 battery rating (basis 8-hour discharge rate)

2	
4.1250 ampere rating for battery 48-hour supply (nearest battery E. S. B. Co.'s Type ET couple, 4½ amp.).	

The charging medium required would be a 5 ampere D.C. motor-generator or a rectifier delivering this current at 30 volts. If it is desired to operate an interrupter ringing outfit from the storage battery the size of the latter should be increased from 1½ to 3 amperes, depending on the amount of ringing to be done.

SWITCHBOARDS—PRIVATE BRANCH EXCHANGE

No. 1801

Sectional Unit Type

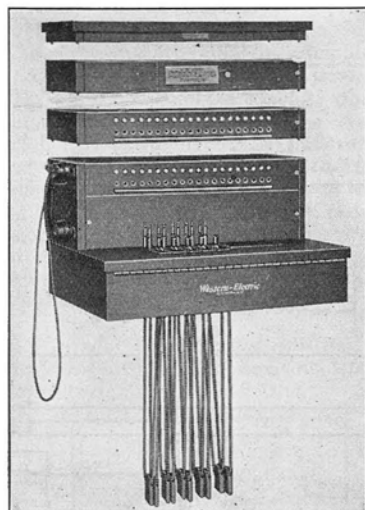

**No. 1801 Switchboard
Showing Method of Enlarging**

The Western Electric 1801 P.B.X. is a manual, central battery system utilizing a small single position, non-multiple switchboard of the sectional unit type. It is especially suitable for use in:

Medium size industrial plants	Hospitals and sanitariums
Department stores	Hotels
Apartment buildings	Prisons
Schools	Public buildings

The 1801 P. B. X. may be used with either a dial or a manual central battery central office. It is flexible and economical in operation, particularly suited to locations where the final capacity cannot be determined initially and is readily adaptable to the diversified line and traffic conditions encountered on private branch exchanges.

GENERAL DESCRIPTION

The units which comprise the 1801 P.B.X. can be assembled in the same way as those of a sectional bookcase.

The names of these units and their usual positions in the switchboard assembly are as follows:

Top Unit	Line Units
Incoming Call Transfer Key Unit	Cord Unit
Simultaneous Talking and Ringing Unit	Supporting Unit
Line Relay Unit	

With the exception of the top, cord and supporting units, the units may be mounted interchangeably. The number and kind to be used will depend upon the requirements of each installation. Additions may be made at any time without the necessity of extensive wiring changes. This simplifies building up the board.

The equipment units are compact and strongly constructed. The wood may be either oak in dull red oak finish, or birch in mahogany finish. When assembled, the units are fastened to each other with a single screw at each end. The face panels are hinged, providing ready access to the apparatus and wiring and when closed are held securely in place by means of thumb screw locks. The rear of each unit is permanently closed. This arrangement permits the switchboard to be mounted on the wall in a stationary position.

Screw terminals are used for terminating the incoming station lines and the central office trunk circuit leads and for the necessary wiring between units.

Station line and trunk pairs may be brought into the units by means of switchboard or lead covered cable or ordinary twisted pair station wiring.

SWITCHBOARDS—PRIVATE BRANCH EXCHANGE

Sectional Unit Type—Continued

CIRCUIT FEATURES

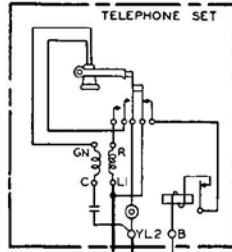

NOTES—
 A—"M" WIRING AND APPARATUS WHEN LINE RELAY IS USED, OTHERWISE "N" WIRING
 B—"Z" WIRING WHEN SIMULTANEOUS RINGING AND TALKING IS USED, OTHERWISE "W" WIRING

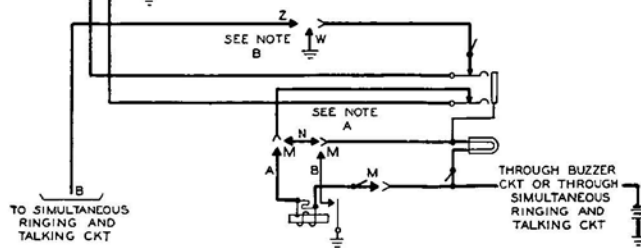

Station Line Circuit—"System C"

The circuits of the 1801 Switchboard are so designed as to reduce operating procedure and maintenance to a minimum.

Cord Circuits. The cord circuits are of the repeating coil type and are arranged for station line lamp supervision. A relay in the cord circuit functions as the repeating coil.

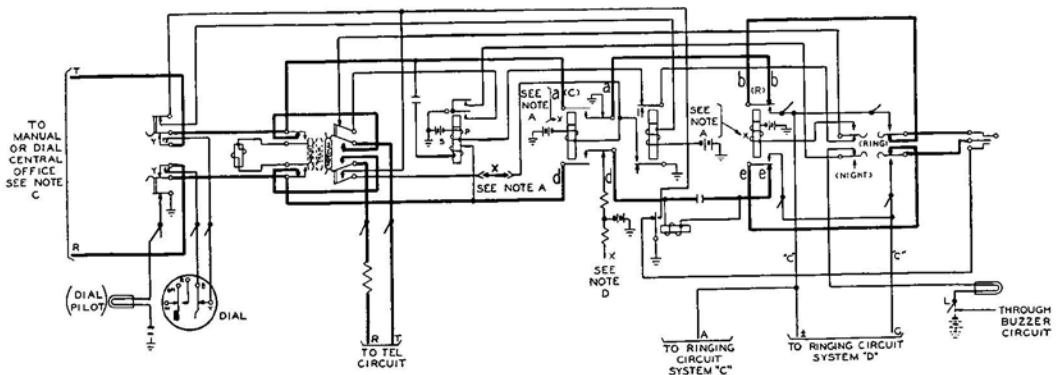

NOTES—
 A- USE "X" APPARATUS AND OMIT "X" WIRING WHEN SYSTEM "C" IS REQUIRED USE "X" APPARATUS AND "X" WIRING WHEN SYSTEM "D" IS REQUIRED AND IS TO BE ARRANGED FOR SIMULTANEOUS RINGING AND TALKING, OTHERWISE OMIT "X" APPARATUS AND LOOP LEADS "22", "D", "D" AND "66" AT POSITIONS OF RELAYS (C) AND (R)

B- "C" LEADS ARE RUN IN SEPARATE CABLE.
 C- THE TIP WINDING OF THE 1000^Ω/1000^Ω LINE RELAY IN THE MANUAL CENTRAL OFFICE LINE CIRCUIT SHOULD BE SHORT CIRCUITED WHEN CONNECTED TO THIS TRUNK
 D- ONE RESISTANCE PER TWO TRUNK CIRCUITS.

**Trunk Circuit
 To Manual C.O.—"System C"
 To Manual or Dial C.O.—"System D"**

SWITCHBOARDS—PRIVATE BRANCH EXCHANGE**Sectional Unit Type—Continued**

Trunk Circuits. The trunks which connect the P.B.X. to a central office are cord ended. This makes it unnecessary to use a cord circuit for connecting a trunk to a station line. A lamp is associated with each trunk cord to indicate incoming trunk calls.

Line Relay Circuit. A Line Relay Unit is available for use when stations are located at a considerable distance from the switchboard.

Dial Service. A dial may be used by the attendant in originating and completing outgoing trunk calls when trunks are connected to a dial central office.

Group Ringing and Talking. Means are provided whereby the attendant may ring simultaneously a group of forty station lines and then talk simultaneously to this same group of lines. Cord circuits are not required for this simultaneous ringing and talking service but connections are made directly between the attendants' telephone set and the station lines through the wiring of the buzzer and line circuits. The lines to be equipped for this service should be specified by the customer.

Incoming Call Transfer. An incoming call transfer key is provided and so wired that when operated all incoming calls from all station lines will be answered by a predetermined station line. This service is usually provided when the switchboard is unattended and avoids the necessity of going to the P.B.X. to answer the call. No intercommunication between station lines is possible with this arrangement. The incoming call transfer unit is provided for this purpose and is similar in construction to the simultaneous ringing and talking unit.

Facilities for Night Service. Incoming central office calls for night service are directly connected through the trunk cord to the station lines other than the line connected to the incoming call transfer unit.

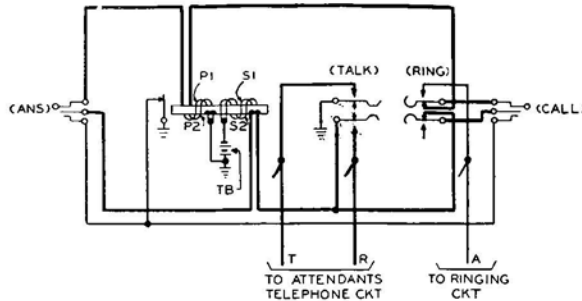

Cord Circuit—"System C"

EQUIPMENT ARRANGEMENTS

The following four equipment arrangements are available:

System A—Communication between attendant and stations.

System B—Communication between attendant and stations.
Intercommunication between stations.

System C—Communication between attendant and stations.
Intercommunication between stations.
Trunk lines to a Central Battery Central Office.
Direct Current Ringing.

System D—Similar to System C except that station bells are rung with alternating current and the trunks of System D may be connected into either a Dial or a Manual Central Battery Central Office.

POWER REQUIREMENTS

Since the quality of service obtained from a P.B.X. is affected materially by the efficiency of the power supply, power equipment designed particularly for this kind of service should be selected.

For talking, signaling and direct current ringing, the 1801 P.B.X. requires a 20-28 volt, single battery supply. The 20 cycle alternating current ringing current required for System D may be obtained from a source outside the P.B.X. or at the P.B.X. by the use of a hand generator.

A description of power apparatus under the heading, "Supplementary Equipment," pages 235-6, is given in order to enable the user to select the equipment best suited to render satisfactory service in the operation of the 1801 P.B.X. Consideration is given to the need for maintaining at low levels the ringing and talking current introduced between cords and reducing to a minimum the charging generator noise on circuits.

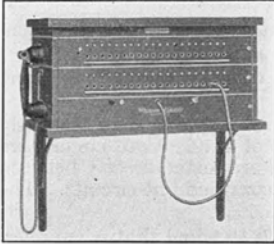
SWITCHBOARDS—PRIVATE BRANCH EXCHANGE**Sectional Unit Type—Continued****SYSTEM A**

No. 1801 P.B.X. Switchboard.
System A Wall Mounted

System A provides for communication between the switchboard and stations only. There are no facilities for intercommunication between stations or for connections to a central office.

Direct current is used for ringing the station line bells. The same battery is used for ringing, signaling and talking current.

System A is a three wire system. There are two wires individual to each station and a third wire common to all stations. When a station is rung, ringing current passes out over the tip side of the line through the bell in the telephone and back over the third wire.

Since the operator is a party to all conversations, no facilities for supervision are required.

The illustration at left shows an assembly of System A. Additional equipment units and supplementary apparatus may be had and installed as required. The equipment available for use with System A is as follows:

Equipment Units	Supplementary Apparatus	
Line Units	HA-1	Attendant's Handset E1B3
	HB-1	Attendant's Desk Stand 1040AL
	HC-1	
	HD-1	
*Cord Unit	JU -1	
Station Line Relay Unit	HA-2	Additional Line Circuit equipment.
Incoming Call Trans. Key	HB-6	Additional Line Relay Circuit equipment.
Simultaneous Ringing and Talking Key	HA-9	Battery and Charging Rectifier.

* Includes Top Unit and Supporting Brackets.

Complete description of these units will be found on pages 234-5 under the heading, "Description of Units," and on pages 235-6 under the heading, "Supplementary Equipment."

SYSTEM B

This system provides for communication between the attendant and stations and intercommunication between stations. Five pairs of connecting cords with ringing and listening keys are provided for the cord circuits.

The same battery is used to provide direct current for ringing, signaling and talking. System B is a three wire system. A third wire common to all stations is used in addition to the two wires individual to each station. When a station is rung, ringing current passes out over the tip side of the line through the bell in the telephone and back over the third wire.

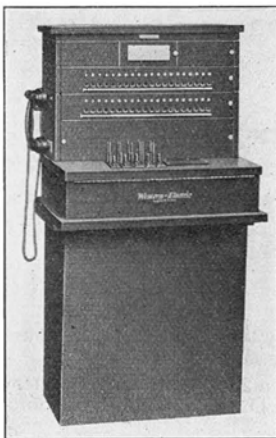

No. 1801 P.B.X. Switchboard.
System B Wall Mounted with
Cord Casing

As soon as a connection is set up, the line lamps of the connected lines become supervisory lamps; remaining dark as long as the parties have their receivers off the hooks, and lighting when they hang them up.

The cord unit of System B is universally wired so that the board may be converted to System C or D for trunk service with only minor modifications.

Illustration at left shows an assembly of System B. Other units and supplementary apparatus may be used, if desired. The equipment which may be used with System B is as follows:

Equipment Units	Supplementary Apparatus	
Line Units	HA-1	Attendant's Handset E1B3
	HB-1	Attendant's Desk Stand 1040AL
	HC-1	
	HD-1	
*Cord Unit	JU -2	Additional Station Line position equipment
Station Line Relay Unit	HA-2	Additional Line Relay equipment
Incoming Call Trans. Key	HB-6	Battery and charging rectifier

(Continued on next page)

SWITCHBOARDS—PRIVATE BRANCH EXCHANGE
Sectional Unit Type—Continued

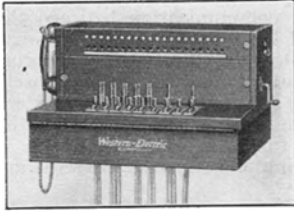

No. 1801 P.B.X. Switchboard,
 System B Wall Mounted Cord
 Casing Omitted

Equipment Units

Simultaneous Ringing and Talking Key	HA-9
Cord casing and supporting brackets	K-2
Cord casing without brackets	K-5
Desk and supporting brackets	K-3
Supporting Brackets (Desk)	K-4
Supporting Brackets (Wall)	K-6

* Top unit included.

Complete descriptions of these units will be found on pages 234-5 under the heading, "Description of Units," and on pages 235-6 under "Supplementary Equipment."

SYSTEM C

System C provides for communication between the attendant and stations and for intercommunication between stations. In addition this system may be equipped with two plug ended trunks for connection into a manual central battery central office. Five pairs of connecting cords with ringing and listening keys are provided for the cord circuits.

A battery is used to provide direct current ringing and talking current. This system, like Systems A and B, is a three-wire system. A third wire common to all stations is used in addition to the two wires individual to each station. When a station is rung, ringing current passes out over the tip side of the line through the bell in the telephone and back over the third wire.

The cord unit for System C is universally wired so that a change-over to alternating current ringing can be made with minor modifications.

When a connection is set up, the line lamps associated with the connected lines become supervisory lamps, remaining dark as long as the connection is up and lighting when the circuit is broken.

The trunk circuits are provided with holding, ringing and listening keys and the operator's telephone circuit and station line telephone sets are equipped with induction coils. The holding key enables the operator to hold a trunk connection while she converses with the party called or until the party wanted can be connected. The induction coils insure good transmission on trunk connections.

The trunk circuits are connected to a regular subscriber's line circuit at the central office. When a trunk is plugged into a station line on which the receiver has been removed from its hook, the central office operator will receive the usual signal. The private branch exchange attendant can signal the central office operator by means of the holding key.

To signal the P.B.X. operator, the central office operator rings out on a line to which a trunk is connected. This lights the trunk lamp at the P.B.X., which remains lighted until the listening key is operated. Talking current is obtained from the central office on trunk connections except when the holding key is operated. Then current is used from the local battery at the P.B.X.

Trunks may be set up for night service so that central office calls can be answered or originated by the particular station lines which are connected to the trunks.

A night key is provided to prevent the battery current from flowing when trunks are set up for night service.

The equipment which may be used in System C is as follows:

Equipment Units	Supplementary Apparatus
Line Units	HA-1 Attendant's Handset E1B3
	HB-1 Attendant's Desk Stand 1040AL
	HC-1 Station Telephone Set 1533M
	HD-1
*Cord Units without trunks	JU -3 Additional Line Relay equipment
Cord Units with trunks	JU-3T Additional Station Line Position equipment
Station Line Relay Unit	HA-2 Battery and charging equipment
Incoming Call Transfer Key	HB-6
Simultaneous Ringing and Talking Key	HA-9
Desk and Supporting Units	K-3
Supporting Brackets (Wall)	K-6
Supporting Brackets (Desk)	K-4
Cord Casing and Supporting Brackets	K-2
Cord Casing without Brackets	K-5

* Top Unit included.

Any of the units and supplementary apparatus listed may be used.

Complete description of these units will be found on pages 234-5 under the heading, "Description of Units," and on pages 235-6 under the heading, "Supplementary Equipment."

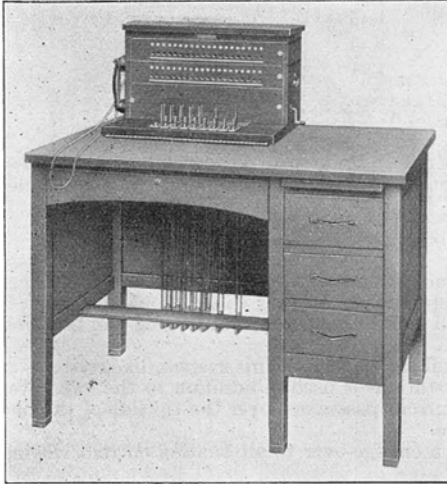
SWITCHBOARDS—PRIVATE BRANCH EXCHANGE**Sectional Unit Type—Continued****SYSTEM D**

No. 1801 P.B.X. Switchboard. System D Desk Mounted

System D provides for communication between the attendant and stations, and intercommunication between stations. It differs from System C in that alternating current is used for ringing and a two wire line circuit is used.

Five pairs of connecting cords with ringing and listening keys are provided for the cord circuit. A dial for the use of the attendant will be furnished when specified.

The direct current talking and signaling currents are supplied by battery.

A ringing interrupter can be supplied for furnishing alternating ringing current. This System may be equipped with two plug ended trunks for connection into a manual central battery central office.

When a connection is set up, the line lamps associated with the connected lines becomes supervisory lamps remaining dark as long as the connection is up and lighting only when the circuit is broken.

The trunk circuits are provided with holding, ringing and listening keys and the operator's telephone circuit and the station line telephone sets are equipped with induction coils. The holding key enables the operator to hold a trunk connection while she converses with the party desired or until the party wanted can be connected. The induction coils insure good transmission on trunk connections.

When trunk circuits are equipped they are connected to a regular subscriber's line circuit at the central office. When a trunk is plugged into a line on which the receiver has been removed from the hook, the central office operator

will receive a signal in the usual manner. The private exchange attendant also can signal the central office operator by means of the holding key.

To signal the P.B.X. operator, the central office operator rings out on the line in the usual manner. This action lights the trunk lamp which remains lighted until the listening key is operated. Talking current is obtained from the central office on trunk connections except when the holding key is operated. Then current from the local battery is used.

A night key is provided to prevent the battery current from flowing when trunks are set up for night connection.

Trunks may be set up for night service so that a station line to which a trunk is connected can originate or receive central office calls.

The cord units for System D include an emergency Hand Generator (No. 22A) which is used when the board is not equipped with long line relays or for simultaneous ringing and talking. When either or both of these features are included in the board, the No. 48A Hand Generator is furnished.

System D is universally wired so that, if necessary, the switchboard can be converted with a minimum of inconvenience to direct current ringing.

Illustration above shows an assembly of System D, mounted on a flat top desk. The following is a complete list of the items which may be used in System D:

Line Units	Equipment Units	Supplementary Apparatus	
	HA-1	Attendant's Handset	E1B3
	HB-1	Attendant's Desk Stand	1040AL
	HC-1	Station Telephone Sets	1553A
	HD-1		1553B
*Cord Units without trunks	JU-4		
Cord Units with trunks	JU-4T	Additional Line Relay Equipment.	
Station Line Relay Unit	HA-2	Additional Station Line Position equipment.	
Incoming Call Transfer Key Unit	HB-6	Battery and charging equipment.	
Simultaneous Ringing and Talking Key Unit	HA-9		
Desk and Supporting Unit	K-3	Dial equipment	
Supporting Brackets (Wall)	K-6		
Supporting Brackets (Desk)	K-4		
Cord Casing and Supporting Brackets	K-2		
Cord Casing without Brackets	K-5		

* Top Unit included.

Any of the units and supplementary apparatus listed may be added as required.

Complete description of these units will be found on pages 234-5 under the heading, "Description of Units," and on pages 235-6 under the heading, "Supplementary Equipment."

SWITCHBOARDS—PRIVATE BRANCH EXCHANGE**Sectional Unit Type—Continued****Equipment List and Capacities**

With the exception of the supporting units and brackets, which are of metal, the units contained in the following table will be furnished in oak or mahogany finish, as specified.

	Units per P.B.X.	Number of Circuits Wired Equip'd		System A	System B	System C	System D
Cord Unit Consisting of: Attendant's Telephone Circuit Station Line Circuits	1	1 20	1 20	JU-1	JU-2		
Attendant's Telephone Circuit Station Line Circuits Cord Circuits		1 20 5	1 20 5				
Attendant's Telephone Circuit Station Line Circuits Cord Circuits Trunk Circuits (Note C)		1 20 5 2 or 2	1 20 5 0 or 2			JU-3 or JU-3T	JU-4 or JU-4T
Station Line Units	5	20 20 20 20	5 10 15 20	HA-1 HB-1 HC-1 HD-1	HA-1 HB-1 HC-1 HD-1	HA-1 HB-1 HC-1 HD-1	HA-1 HB-1 HC-1 HD-1
Station Line Relay Unit	1	5	2	HA-2	HA-2	HA-2	HA-2
Incoming Call Transfer Key Unit	1	1	1	HB-6	HB-6	HB-6	HB-6
Simultaneous Ringing and Talking Key Unit	3	1	1	HA-9	HA-9	HA-9	HA-9
Cord Casing & Supporting Brackets or	1				K-2	K-2	K-2
Cord Casing without Brackets	1				K-5	K-5	K-5
Desk & Supporting Brackets or	1				K-3	K-3	K-3
Supporting Brackets (Desk)	1				K-4	K-4	K-4
Supporting Brackets (Wall)	1			K-6	K-6	K-6	K-6
Ringling, Talking & Signaling Power Supply				Note A	Note A	Note A	Note B
Attendant's Handset Attendant's Desk Stand				E1B3 1040AL	E1B3 1040AL	E1B3 1040AL	E1B3 1040AL

Note A—The talking, signaling and ringing power equipment for Systems A, B and C should consist of a rectifier charging a 24 volt battery. For further description of Power Equipment, see page 236.

Note B—The talking and signaling power equipment for System D is similar to that described under Note A. Power for ringing is taken directly from a continuous alternating current supply. See page 236 for further description of power equipment.

Note C—System C Cord Units—Trunks arranged for operation with manual central battery central office only.

System D Cord Units—Trunks arranged for operation with dial or manual central battery central office.

PRIVATE BRANCH EXCHANGE**Section Unit Type—Continued**

DESCRIPTION OF UNITS*

K-2 Cord Casing (Systems B, C and D). A wooden casing for covering the cords when the switchboard assembly is mounted on a wall. Furnished in either oak or mahogany finish. A set of two metal shelf brackets included.

K-3 Desk and Supporting Brackets (Systems B, C and D). Consists of a flat top desk and K-4 Supporting Brackets for mounting the switchboard assembly. The cords which are suspended from the cord unit are accommodated in a well in the top of the desk.

K-4 Supporting Brackets (Systems B, C and D). Two metal brackets for mounting the 1801 switchboard on a desk.

K-5 Cord Casing without Brackets (Systems B, C and D). The K-5 Cord Casing is similar to the K-2 Cord Casing except that Supporting Brackets are not included.

K-6 Supporting Shelf Brackets (Systems B, C and D). Two metal brackets for use in mounting the switchboard assembly on the wall.

EQUIPMENT UNITS



HD1 Line Unit

Line Units (Systems A, B, C and D). The line units are wired for a capacity of 20 station lines. Jack and lamp positions are equipped in multiples of five. The blank positions are provided with apparatus blanks and may be equipped when desired.

Unit	Wired	Equipped
HA-1	20	5
HB-1	20	10
HC-1	20	15
HD-1	20	20

* See chart on the previous page as handy reference to normally required number of units with associated apparatus and capacity of units in each respective system.

HA-2 Line Relay Unit (Systems A, B, C and D). The Line Relay Unit is wired for a capacity of 5-line relays for use with lines to remotely located stations. Two line relay circuits are equipped and mounting plates are furnished for the three unequipped positions. The blank positions can be equipped as required.

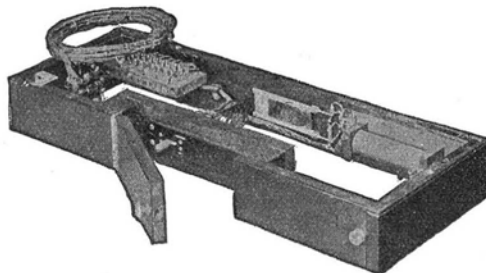

No. HB-6 Incoming Call Transfer Unit (Open and Closed Views)

HB-6 Incoming Call Transfer Key Unit (Systems A, B, C and D). The incoming call transfer key unit, which is used when the switchboard is unattended and station line calls are to be answered at a predetermined station line position, is wired and equipped for one incoming call transfer key circuit.



No. HA-9 Simultaneous Ringing and Talking Unit, Open



No. HA-9 Simultaneous Ringing and Talking Unit, Closed

HA-9 Simultaneous Ringing and Talking Key Unit (Systems A, B, C and D). This unit is wired and equipped for simultaneous ringing and talking by the attendant on a group of as many as 40 station lines. A maximum of three units may be provided although only one can be operated at a time. The station lines to be assigned to each grouping circuit will be as specified by the customer.

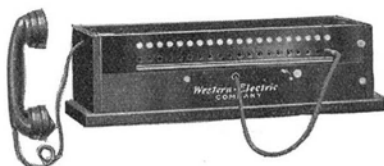
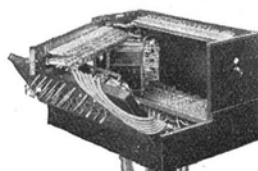
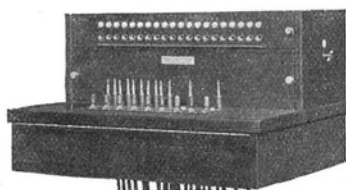
PRIVATE BRANCH EXCHANGE**Section Unit Type—Description of Units—Continued****CORD UNITS****JU-1 Cord Unit****JU-3 Cord Unit. Closed View, and Open Showing Gate**

JU-1 Cord Unit (System A). The cord unit for use with System A is wired and equipped for 20 station lines, cord and telephone circuit, buzzer, talking and ringing supply circuits and provision for cross connection to the line units, the line relay unit, the incoming call transfer unit and the simultaneously ringing and talking key unit. This unit includes Top Unit and Supporting Brackets for wall mounting.

JU-2 Cord Unit (System B). The JU-2 cord unit for System B is wired and equipped for 20 station line circuits, five cord circuits, one buzzer circuit, attendant's telephone circuit and direct current ringing circuit.

Terminals are provided for cross connection of wiring between the cord unit and the adjacent line units, simultaneous ringing and talking key unit, incoming call transfer key unit and the line relay unit.

JU-3T Cord Unit (System C). The JU-3T Cord Unit for System C is wired and equipped for 20 station line circuits, five cord circuits, one buzzer circuit, attendant's telephone circuit, direct current ringing circuit and two trunk circuits.

Terminals are provided for cross connection of wiring between the cord unit and the adjacent line units, simultaneous ringing and talking key unit, incoming call transfer key unit and the line relay unit.

JU-3 Cord Unit (System C). The JU-3 Cord Unit is similar to the JU-3T Cord Unit except that the two trunk circuits are unequipped. Apparatus blanks are provided for the unequipped positions. The equipment for the trunk circuits can be ordered and installed when required.

JU-4T Cord Unit (System D). The JU-4T Cord Unit for System D is wired and equipped for 20 station line circuits, five cord circuits, one buzzer circuit, attendant's telephone circuit, alternating current ringing circuit and two trunk circuits.

Terminals are provided for cross connection of wiring between the cord unit and the adjacent line units, simultaneous ringing and talking key unit, incoming call transfer key unit and the line relay unit.

JU-4 Cord Unit (System D). The JU-4 Cord Unit is similar to the JU-4T Cord Unit except that the two trunk circuits are unequipped. Apparatus blanks are provided for the unequipped positions. The equipment for the trunk circuits can be ordered and installed when needed.

SUPPLEMENTARY EQUIPMENT

The following miscellaneous equipment and apparatus is required in connection with the regular units of the 1801 P.B.X. Switchboard in order to provide a properly connected system and to provide for the various optional circuit features. The equipment for these optional features is usually mounted locally. The following items will be furnished only when specified in the order.

Jacks and Lamps (Station Line) (Systems A, B, C and D)

For one or more station line circuits. Equipment includes the jack, lamp socket, lamp and lamp cap. Added when required to the partially equipped HA-1, HB-1 and HC-1 Line Units.

Line Relays (Systems A, B, C and D)

From one to three line relays may be added to the partially equipped HA-2 Line Relay Unit. The necessary mounting plates are furnished initially with the Line Relay Unit.

Trunk Circuit Equipment—Two Trunks (Less Dial) for System D without Simultaneous Ringing and Talking Unit

This item covers the relays, condenser, cord, keys, retardation coil and lamps required to equip two central office trunks in the cord unit for System D.

Trunk Circuit Equipment—Two Trunks (Less Dial) for System D with Simultaneous Ringing and Talking Unit and System C with or without Simultaneous Ringing and Talking Unit

This item covers equipment required to equip two central office trunk circuits in the cord unit in System D with simultaneous ringing and talking and System C with or without simultaneous ringing and talking key circuit.

SWITCHBOARDS—PRIVATE BRANCH EXCHANGE**Section Unit Type—Description of Units—
Supplementary Equipment—Continued****Attendant's Telephone Sets (Systems A, B, C and D).**

Two operators' telephone sets are available. These are the 1040AL Desk Stand, illustrated on page 75, and the E1B3 Handset, illustrated on page 101. The latter includes a 4A handset hanger, mounting screws and pad.

Dial Equipment (System D).

This equipment includes the dial mounting, dial adapter, dial, dial key, lamp, lamp socket, lamp cap and associated equipment required to dial over the trunks in System D.

A complete set of tools is furnished with each cord unit for purpose of adjustment and maintenance.

Generators for A.C. Ringing (System D).

When the simultaneous ringing and talking unit is provided, a continuously operated source of ringing supply capable of delivering a 20 cycle alternating current of a minimum of one-tenth ampere at 75 volts is required to ring the maximum load of 40 stations.

When the simultaneous ringing and talking feature is omitted practically any commercial type of 20-cycle alternating current ringing supply will be satisfactory if it does not introduce objectionable noise on the battery, and the peak ringing voltage does not exceed 165 volts.

Storage Battery (Systems A, B, C and D).

The battery should be a storage battery with a minimum capacity of about 18 ampere hours (at the $\frac{1}{2}$ ampere rate) and should consist of sufficient cells (11 or 12) to provide a voltage at all times of 20-28 volts at the P.B.X.

In order to reduce cross-talk and direct current ringing introduction between cords to a low value, it is recommended that the entire battery have not more than $\frac{1}{2}$ ohm resistance.

Charging Equipment (Systems A, B, C and D).

A small battery charger of the full wave type is recommended. A charger of this type with a suitable choke coil to smooth out the wave, can be operated across the battery feeding talking current without introducing output hum into the talking circuits.

SUMMARY

In design and construction the 1801 Switchboard provides a telephone system capable of fulfilling every need of the small private branch exchange, with or without connections to a central office.

In this Board, extreme versatility has been achieved without the sacrifice of simplicity. Whether for dial or manual operation, it may be installed originally by the use of a few interchangeable units and then be expanded economically to greater capacity or for more diversified service by the use of only the additional units required—each step being taken with a minimum of inconvenience and without discarding the equipment already in use.

SWITCHBOARDS—PRIVATE EXCHANGE

No. 551 Type PBX Switchboard

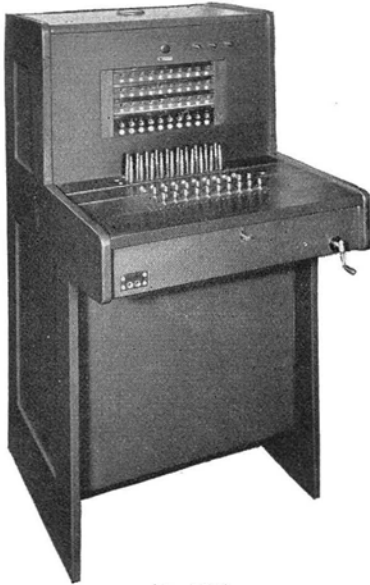

No. 551A

NO. 551A PBX

General

The No. 551A PBX Switchboard is of the single position, non-multiple type and is arranged for operation with either a manual or a dial central office and may be operated on battery obtained over cable pairs from a central office. Ringing current is usually obtained from the central office. This PBX employs circuits identical with those which were used in the No. 550C, 30 line PBX. The framework however is an improved type designed to facilitate the maintenance of the board.

This switchboard may be obtained in either oak-natural finish or in mahogany with a mahogany-walnut finish. The lumber is kiln dried and thoroughly seasoned to prevent warping and cracking.

Capacity

The capacity of the No. 551A PBX is as follows:

Station Line Circuits.....	40
Trunk Circuits.....	10
Cord Circuits.....	10

Provision is made so that ten of the station line circuits may be equipped with line relays when the conductor resistance of certain of the station lines is high.

Any desired number of station lines, trunks and cord circuits within the capacity of the board can be equipped as specified. Complete switchboards with definite amounts of equipment to meet average conditions are listed below.

	List No. 1	List No. 2	List No. 3	List No. 4
Station Line Circuits regular.....			10	20
Station Line Circuits arranged for but not equipped with line relays.....	10	10	10	10
Trunk Circuits.....	4	5	6	8
Cord Circuits.....	5	6	8	10

Although this switchboard is usually furnished as a single unit, two switchboards may be lined up together by placing them end to end without removing the end panels.

Framework

The framework for the switchboard is arranged with a hinged gate upon which all of the relay equipment is mounted. The gate extends only to the height of the cord shelf so that the cords may be tested, and if necessary changed, without opening the gate.

The terminal strips on which the station line and trunk circuits are terminated are so located that they are fully exposed for maintenance purposes when the rear door is removed from the switchboard.

The keyshelf, lockrail and front panel are covered with black phenol fibre. The plug rail is covered with black semi-hard rubber.

SWITCHBOARDS—PRIVATE EXCHANGE

No. 551 Type PBX Switchboard—Continued

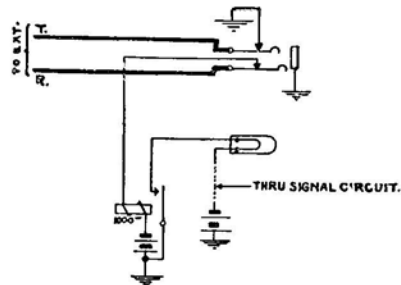

Line Circuit of Nos. 551A and B Switchboards

Line Circuits

The station line circuits are terminated on strip mounted jacks. Lamp signals are directly associated with these jacks. Connections are established between these lines or between a line and trunk by means of cords arranged for double supervision on calls between station lines and for through supervision on outgoing and incoming calls completed over central office trunks.

Trunk Circuits

Trunk circuits are terminated on individually mounted jacks. Lamp signals are directly associated with these jacks.

Cord Circuits

The cord circuits embody all of the features required for the successful operation of the private branch exchange. Each cord circuit is arranged for dialing by the operator from the board and through dialing from any station on the private branch exchange to the machine switching exchange. This through dialing is accomplished by the operator throwing the "Night and Through Dial" key.

Dial Circuit

Provision is made for a dial should there be need for one.

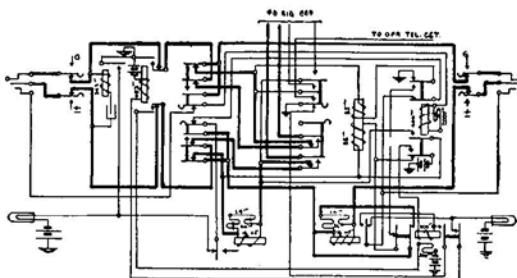

Cord Circuit of Nos. 551A and B Boards

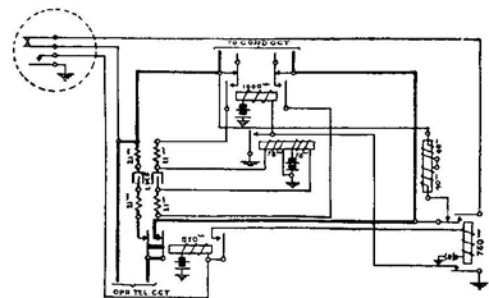

Dialing Circuit of Nos. 551A and B Boards

**SWITCHBOARDS—PRIVATE
EXCHANGE**

No. 551B PBX

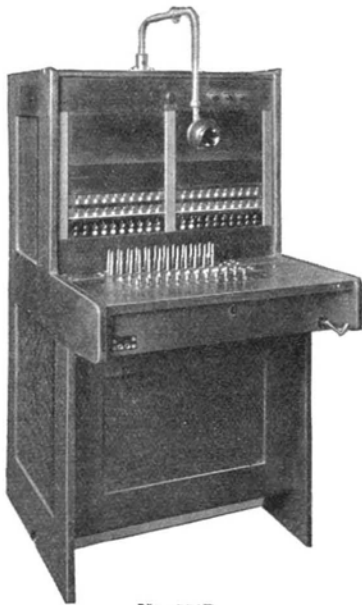

No. 551B

The No. 551B PBX is similar to the No. 551A except in regard to the capacity. The No. 551B has a larger capacity as shown below:

Station Line Circuits.....	320
Trunk Circuits.....	15
Cord Circuits.....	15

Provision is made so that 20 of the station line circuits may be equipped with line relays when the conductor resistance of certain of the station lines is high.

This switchboard has a maximum capacity of 320 lines but may be had with a capacity of 80 lines, the different capacities being arranged for by the use of different local cables.

Should there be a need for a capacity greater than the maximum of one section it is possible to line up two or more sections and bolt them together without removing the sides.

Complete switchboards with definite amounts of equipment to meet average conditions are given in the following table:

List 1—Equipped for 40 lines, 6 trunks and 10 cord circuits

	Wiring	Equip.
Station Line Circuits, regular.....	60	20
Station Line Circuits arranged for but not equipped with line relays.....	20	20
Trunk Circuits.....	15	6
Cord Circuits.....	15	10

List 2—Equipped for 40 lines, 8 trunks and 12 cord circuits

Station Line Circuits, regular.....	60	20
Station Line Circuits arranged for but not equipped with line relays.....	20	20
Trunk Circuits.....	15	8
Cord Circuits.....	15	12

List 3—Equipped for 40 lines, 10 trunks and 15 cord circuits

Station Line Circuits, regular.....	60	20
Station Line Circuits arranged for but not equipped with line relays.....	20	20
Trunk Circuits.....	15	10
Cord Circuits.....	15	15

List 4—Equipped for 120 lines, 8 trunks and 10 cord circuits

Station Line Circuits, regular.....	300	100
Station Line Circuits arranged for but not equipped with line relays.....	20	20
Trunk Circuits.....	15	8
Cord Circuits.....	15	10

List 5—Equipped for 140 lines, 10 trunks and 15 cord circuits

Station Line Circuits, regular.....	300	120
Station Line Circuits arranged for but not equipped with line relays.....	20	20
Trunk Circuits.....	15	10
Cord Circuits.....	15	15

SWITCHBOARDS—PRIVATE EXCHANGE CORDLESS TYPE

No. 506 Type Cordless PBX Switchboard



No. 506A

General

The No. 506 Type Switchboards are single position turrets of the cordless type, all connections being made by the operation of keys.

The circuits are arranged for local manual service and for operation into either manual or machine switching central offices. The wiring and equipment are the same for all systems.

Through dialing to a central office from stations may be provided for by equipping the station telephone set with a dial. The through dial connection is established to the central office by operating a station key and a trunk key in the same connecting circuit. When the PBX is unattended a through connection to the central office (either manual or dial) may be left set up for a certain station line.

A desk stand is provided for the use of the attendant and, when required, a dial is furnished with the desk stand so that connections may be made to a dial central office.

Ordinarily the ringing supply is obtained from the central office. Where the ringing current is not obtained from this source, a hand generator is used for ringing the stations. It also serves as an emergency ringing supply in case of a central office ringing supply failure.

The talking battery is obtained over cable pairs from the central office for local connections and over the trunk conductors on trunk connections. One cable pair is provided in each PBX for battery supply.

Capacity

	Code No.	
	506A	506B
Positions.....	1	1
Trunk Circuits.....	3	5
Connecting Circuits.....	5	5
Station Line Circuits.....	7	12
Attendants Telephone Circuit.....	1	1
Ringing and Buzzer Circuit.....	1	1

Framework and Finish

The framework consists of a wooden base upon which is mounted a wooden key front and all of the relay equipment associated with the switchboard. The key front is mounted in a vertical position near the forward edge of the base and is hinged at the bottom so that it may be dropped down in order to facilitate maintenance. Two triangular shaped gusset plates are mounted on the base and serve as a support for the apparatus mounting plates. A removable wooden cover which slides on metal runners fastened to the base is provided to protect the apparatus and wiring and to facilitate maintenance.

The Nos. 506A & B Boards may be obtained in oak-natural finish or in mahogany with a mahogany-walnut finish.

MAGNETO CORDLESS SWITCHBOARD—10 LINE

The 10 line cordless magneto switchboard is intended for use in an area where the Telephone Company's central office is a magneto exchange or where the conditions are such that power cannot be supplied over cable pairs from central office. This type of switchboard is simple and economical in operation and will provide for the needs of an isolated factory or institution desiring intra-department communication.

This cordless magneto board is equipped with 10 magneto station lines, any of which may be connected to the magneto office for trunking purposes. Five simultaneous connections are provided between lines by keys. There is one operator's telephone circuit, one ringing circuit and a night alarm circuit. The trunks from the central office terminate on drops. This enables central to recall the PBX operator at any time.

The cabinet is furnished in quarter-sawed white oak with a light finish, unless otherwise specified. This board is similar in appearance to the No. 506 type, a cut of which is shown above.

SWITCHBOARDS—PRIVATE BRANCH EXCHANGE

No. 750-A, a Dial System for Residence, Club or Similar Service

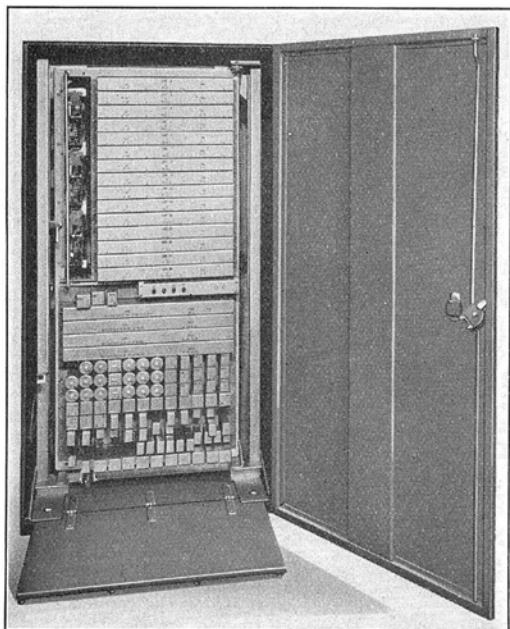

The terminal strips, fuse panel and power equipment are arranged behind the relay gate

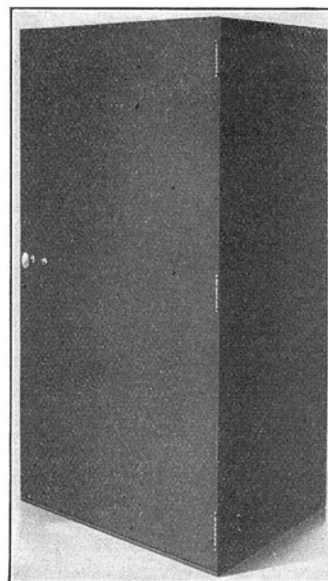

The cabinet which encloses the switching apparatus and power equipment is comparatively small in size and may be installed in a closet or other out-of-the-way place

In the past, a residence requiring local telephone service between rooms, in addition to central office service, installed a manual cord or cordless type P. B. X. or a push button intercommunicating system.

The manual P. B. X. required an attendant to establish all connections. The push button intercommunicating system requires that all lines and central office trunks be terminated at push buttons on a panel at every telephone.

To overcome these disadvantages, Western Electric offers a new development, the No. 750-A Private Branch Exchange employing dial operation. This is a small telephone exchange designed to give complete private telephone service by the dial system to a residence, club or small business institution requiring not more than 15 station lines or extensions and three trunks to central office.

The telephones may be had in either desk or wall type as shown, and in a variety of colors. They are equipped, depending upon the type of service they are to perform, with or without operating keys.

Suitable for Large Residences, Estates, Country Clubs and Similar Locations. The No. 750-A Private Branch Exchange is suited admirably for the large residence or estate with rooms and buildings located at considerable distances apart. Such establishments will find this Western Electric equipment the ideal means for reaching the various departments of the household rapidly and easily.

The golf or country club, with its many centers of activity, can use this system to advantage.

Small industrial organizations will find this dial telephone system the ideal method for inter-departmental communication.

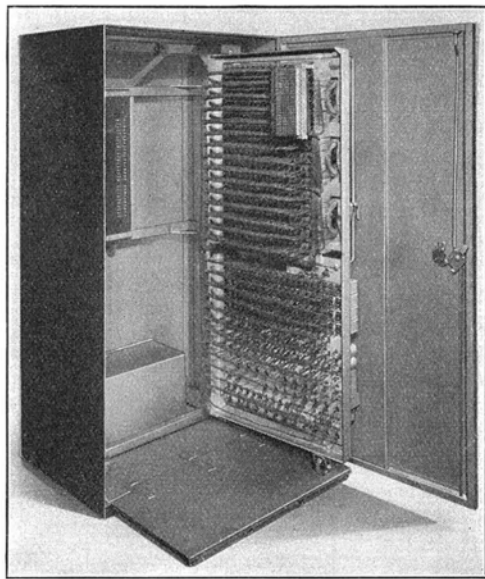
SWITCHBOARDS—PRIVATE BRANCH EXCHANGE**No. 750A—Continued**

When the cabinet door is opened, the steel platform on which the caster of the relay gate rolls may be lowered into position

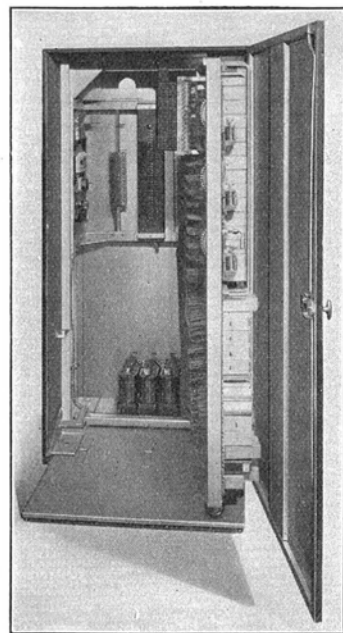

The relay gate is swung open easily, making all parts inside the cabinet quickly accessible. Neat appearance of interior and exterior of cabinet is impressive

Switchboard Capacities. The switchboard may be had in either one of two capacities. One unit consists of 8 station lines, 2 link circuits, and 2 trunk circuits to central office. The larger unit consists of 15 station lines, 3 link circuits and 3 trunk circuits to central office. With the first unit, two local calls and two central office connections can be established at one time. With the second, three local and three central office connections can be established simultaneously.

ASSEMBLY AND ARRANGEMENT OF SWITCHING APPARATUS

The complete switching mechanism and the power equipment are enclosed in a steel cabinet, the dimensions of which are 5' x 2' 7" x 1' 10". The relays are mounted on a hinged rack or gate and may be swung out readily for inspection. This gate rides on a rubber tired roller or caster which rolls on a strongly constructed steel platform. The latter lowers into position after the cabinet door is opened. The terminal strips, fuse panel and power equipment are easily accessible when the gate is swung open.

While all stations are designed for outside as well as intra-house service, some may be confined entirely to the latter if desired.

One or more stations used for outside service may be arranged so that they will connect to a trunk, even though the latter is in use, in the event that an emergency call must be made.

This flexibility of service is obtained by simple wiring changes made at the terminal strips.

Western Electric relays and selectors are employed to perform the switching functions rather than selector and connectors of the step-by-step type.

SWITCHBOARDS—PRIVATE BRANCH EXCHANGE**No. 750A—Continued****POWER SUPPLY**

The P. B. X. operates on 16 to 21 volts D.C., furnished by four batteries connected in series. The batteries may be charged through a cable pair from the central office or by means of a local Rectox charger. Each battery is provided with colored balls to indicate the specific gravity of the electrolyte. These indications simplify maintenance considerably.

NEWLY DESIGNED HANDSET

A handset, with a dial and five keys mounted in its base has been especially designed for this P. B. X. The present set is a distinct improvement in appearance and operation over similar equipment available



A handset, with a dial and five keys mounted in its base, has been especially designed for this P. B. X. System

A wall set with dial and separate key box may be used as well as a standard handset or desk stand

in the past. The keys which are lettered or numbered to correspond to the trunk connection provide an efficient means of making or answering central office calls. The dial is used to make all intra-house calls as well as calls through a dial central office.

Operating Procedure. The operation of the exchange is simple. A party within the system wishing to call any other party within the system lifts the receiver or handset and dials the desired number. If the called station is busy he receives a busy signal; if idle he hears the familiar ring-back tone. The switching equipment is at all times under the control of the calling party and will return to normal automatically as soon as the receiver is replaced.

A call to central office is initiated by lifting the receiver or handset and pressing one of the trunk keys. If the trunk associated with the particular key depressed is already in use, a busy signal is returned. The procedure is repeated with other trunk keys until an idle trunk is found. If the central office is manual, an operator answers; if panel or step-by-step, a dial tone is heard and the calling station dials the number just as if the station were connected permanently to a central office.

An incoming call to a key station within the private exchange system is announced by the ringing of one or more bells in selected locations about the house. Indicators, conveniently located, show by means of lamps with colored caps upon which of the trunks the incoming call is waiting.

The trunk keys located in the base of the telephone set are colored to correspond with the color of these lamp caps. They are also lettered or numbered. By lifting the receiver and depressing the key correspondingly colored, connection is made with the calling central office.

SWITCHBOARDS—PRIVATE BRANCH EXCHANGE**No. 750A—Continued**

Stations arranged for direct central office service have six-wire circuits and employ telephone sets equipped with keys. Stations used primarily for intra-house service employ two-wire circuits and do not require keys. Stand and handsets, wall sets or desk stands are used at these latter locations.

In order that outside service may be given to the two-wire intra-house stations a small transfer key box is provided at a master key station. By this arrangement any one of three keyless stations may be connected to a central office.

Designed and Constructed to Require Little Attention. The circuits and all operating parts of this exchange have been kept as simple as possible. The system is designed to give continuously efficient service with little need for maintenance and care.



For indicating trunks, a rectangular lamp box, instead of the round one, is preferred for some installations

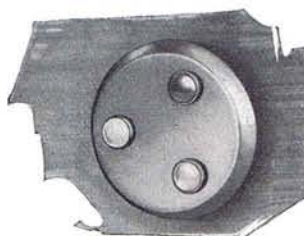

Indicators, conveniently located, show by means of lamps with colored caps upon which of the trunks the incoming call is waiting



In order that outside service may be given to the two-wire intra-house stations a small transfer key box is provided at a master key station

Appearance Suitable for Fine Residences and Estates. The neat appearance and dependable operation of this equipment make the No. 750-A dial type P. B. X. a system worthy of the name Western Electric. The cabinet which encloses the switching apparatus and power equipment is finished in olive green and because of its small size may be installed in a small closet, alcove or similar out-of-the-way space. The door is provided with a lock and key and a handle of brushed brass.

As mentioned, each handset can be furnished in any one of a selected list of colors. The lamp indicator and the transfer key cabinet are finished in keeping with the other equipment.

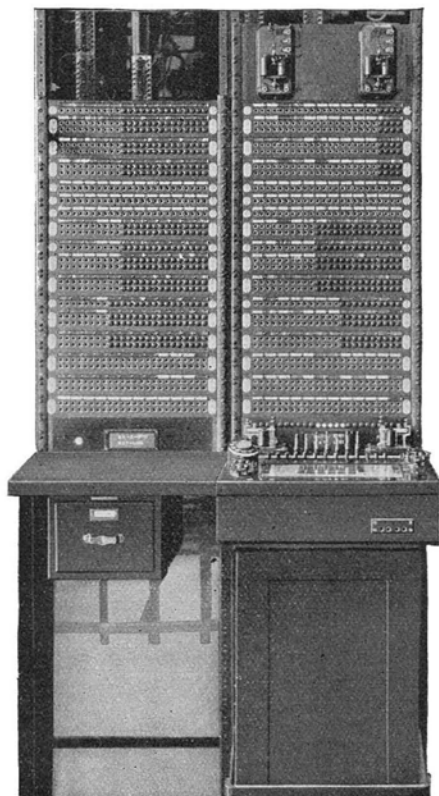
SWITCHBOARDS**TOLL AND TELEGRAPH TEST****NOS. 5, 9 AND 16 TYPES****No. 5 Toll Test Board**

readily accessible to trouble location and measuring tests. A number of arrangements of jack circuits can be provided to meet the requirements of various types of toll circuits in addition to several types of testing facilities providing means of properly maintaining and testing these line circuits.

No. 9 Telegraph Test Board

The No. 9 Telegraph Test Board is similar in construction to the No. 5 Toll Test Board except that it is arranged to provide testing and patching facilities for telegraph lines and their associated telegraph inside plant equipment by means of jacks. These jacks are wired in the telegraph circuits in such a manner that the line repeater and subscriber's equipment may be interchanged by patching and are readily accessible to measurement tests and communication.

No. 16 Toll Test Board

The No. 16 Toll Test Board provides all the jack appearances and testing equipment normally required for testing, patching and maintenance of a limited number of toll and telegraph lines and their associated inside plant equipment. This toll test board may, therefore, be used instead of toll test board No. 5 and telegraph test board No. 9 in smaller offices where it is desirable to concentrate these facilities in one or more bays in this same type of test board.

For further information regarding the above test-boards consult our nearest distributor.

General

The Western Electric Company is prepared to furnish toll and telegraph test board equipment which can be arranged for testing and patching toll and telegraph lines and associated equipment.

These test boards consist essentially of two parts, a lower and an upper unit.

The lower unit consists of a framework upon which is mounted a keyshelf, rear equipment and cordshelf, together with associated apparatus and wiring for testing circuits. These lower units are known as voltmeter test units, Wheatstone bridge units, telegraph test units and combined volt milliammeter, Wheatstone bridge and signal test unit. It is not necessary, however, that each bay be equipped with a lower unit. Where desired a blank writing shelf may be provided. The lower unit mounts on the relay rack framework.

The upper unit consists of a framework upon which is mounted the terminal strips for connecting to outside equipment, apparatus mounting board, piling rail and jack field equipment. Upper units may be obtained in various combinations of jack field equipment to meet requirements.

No. 5 Toll Test Board

The No. 5 Toll Test Board provides testing and patching facilities for toll lines and their associated telephone inside plant equipment by means of jacks. These jacks are wired to the lines in such a manner that the lines or equipment may be interchanged by patching and are

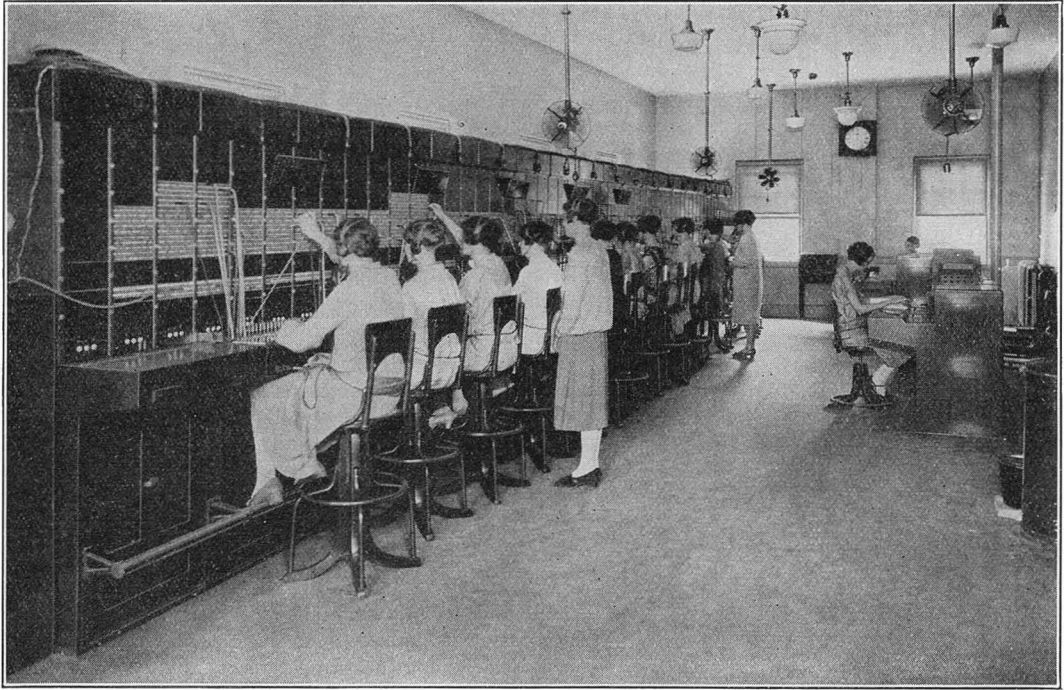
SWITCHBOARDS—CENTRAL BATTERY MULTIPLE

No. 11 Multiple Switchboard in Operation

GENERAL

The idea of using a multiple of the subscribers' lines to speed up telephone service was originated by the Western Electric Company. This practice has been applied to the manufacture of switchboards for a number of years. Flexibility is provided as each operator has every line in the exchange within her reach, thus permitting any line to be called from any position of the switchboard.

The layout of a multiple switchboard warrants careful study. Consideration must be given to the requirements of future growth, the installation of additional equipment as well as other important details. The No. 11 Multiple Switchboard, which is a central office, central battery, manual system board, was designed with these facts in mind.

The design of this board facilitates additions and rearrangements. The upper and lower units are separate, making it possible to meet changing conditions with a minimum outlay of time and expense.

Description of Features

All circuits used in Western Electric switchboards, chief operator's, wire chief's and other desks are thoroughly standardized and represent the ideas of engineers and traffic experts thoroughly versed in the telephone switchboard art. All circuits are designed for dependability and clean-cut operation. All apparatus is of the most modern type employing materials and designs conceived or selected by and worked

SWITCHBOARDS—CENTRAL BATTERY MULTIPLE

(Continued)

out by the largest and most proficient body of telephone engineers in the world operating as one organization unit.

Of particular interest in these days of using mechanical and electrical devices to decrease manual effort, at the same time insuring better and more expeditious results, are the automatic features which the Western Electric Company has selected for the cord circuits of its central battery multiple switchboards. The principal features that increase the operating efficiency, in most cases from 25 to 30%, are those involving automatic ringing and automatic listening as outlined below.

Automatic listening non-interfering answering—is desirable from an operating standpoint as it eliminates opening and closing the cord circuit listening key, after the answering cord has been inserted, to obtain the number desired from the calling party. With automatic listening the operator is in direct communication with the calling subscriber the instant the answering plug is inserted in the jack, provided the call has not been taken by another operator. When the calling plug is inserted in the called subscriber's line, the operator is automatically disconnected.

Automatic or machine ringing controlled by common keys—relieves the operator of any responsibility regarding the ringing with the exception of setting the ringing key to select the proper current where selective ringing other than two-party jack per station is used. Ringing current supplied over the calling cord flows out over the line as soon as the calling plug is inserted in the called subscriber's line jack and the setting key operated. The ringing circuit is interrupted at regular intervals allowing the bell to ring two seconds and remain silent four seconds. This operation continues until the called subscriber answers or the cord is taken down by the operator. The economy effected in the saving of the operator's time fully warrants the installation of this feature. Machine ringing switchboards are arranged for manual ringing on toll and rural lines.

If desired, these boards can be had with all lines arranged for manual ringing control, the advantage of which is the smaller equipment cost. Manual ringing is always under the control of the operator.

Automatic ringing tone to calling subscriber—is a light, yet distinct, ringing tone which is carried back over the answering cord to the calling subscriber's telephone. This allows the calling subscriber to "hear" his party being rung and to know that his call is getting all the attention possible.

Automatic ringing cut-off of machine ringing the instant a call is answered—is essential as it eliminates the possibility of making angry subscribers by ringing them in their ears. The ringing current is positively disconnected the instant the receiver is removed from the called telephone either during the silent or ringing interval.

Automatic flashing recall—feature has become so popular with telephone users and telephone companies that it is considered indispensable in the modern "feature" switchboard. The flashing recall feature provides a persistent signal, demanding instant attention, by flashing the cord circuit supervisory lamp. A calling subscriber after completing one conversation and desiring to call another number, may do so by merely depressing the switchhook and releasing it, which will start the flashing recall and intermittently flash the supervisory lamp in the cord circuit insuring immediate attention by the operator who handled the previous connection. This feature raises the quality of service to the public and makes satisfied subscribers.

Listening-in for supervisory purposes—provides a means whereby the operator can talk to a calling subscriber after the connection has been put up. This is an advantage in clearing up confusing service conditions that are the result of a misunderstanding or misinterpretation.

SWITCHBOARDS—CENTRAL BATTERY MULTIPLE

(Continued)



Operating Room Showing Main Switchboard and Chief Operator's Desk

Switchboard Construction

The switchboard is built up of separate sections. Each section consists of an upper unit and a lower unit as described below.

Upper Unit—The upper framework is arranged in either one-position or three-position lengths consisting of either three or nine $8\frac{1}{2}$ " panels, respectively. The vertical jack opening for face equipment is $2' 7\frac{1}{16}$ " for the single position unit and $2' 11\frac{3}{16}$ " for the three-position.

The single position upper unit has a removable door. The three-position has rear roller curtains which operate easily and allow free access to the back section. These units are provided with a multiple shelf which is equipped with a fire protection panel in the front only. They are arranged for knockdown shipment.

Lower Unit—The lower unit can be removed from one position and placed in another part of the board at any time. These units are a single position section in all cases and of a width to correspond with the three panel upper unit. They are shipped equipped and wired.

Space is provided in the rear of the lower unit for fuse panels, terminal strips, cord circuit relays and repeating coils, and cable brackets for the incoming trunk and miscellaneous cables. The location of the switchboard cable in this position does not interfere with the removal of the lower unit.

The end panels as well as the front panels that conceal the cords are removable.

SWITCHBOARDS—CENTRAL BATTERY MULTIPLE

(Continued)

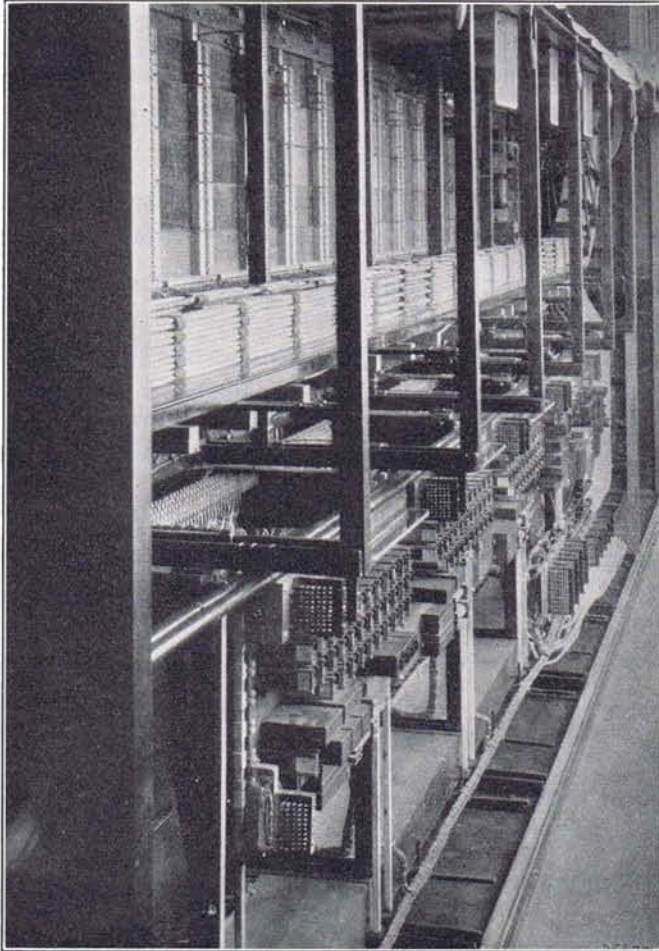
**Rear View of No. 11 Multiple Switchboard.**

A rigid steel skeleton constructed of steel angles and bars securely riveted and bolted together constitutes the structure of the framework. This framework is coated with aluminum paint. Selected birch thoroughly seasoned and kiln dried to prevent warping and cracking is used for the cabinet enclosing the steel framework. All exposed wooden surfaces are given a durable rich mahogany finish and the inner wooden surfaces are coated with shellac as protection against the effects of moisture.

Cold drawn galvanized steel is used for the stile strips which support the face equipment, the key mounting bars that hold the keys in place in the keyshelf, and the relay mounting supports to which the relay mounting plates are attached. Piano type hinges extending the full length of the key shelves are used on all boards.

SWITCHBOARDS—CENTRAL BATTERY MULTIPLE

(Continued)

Each line-up of switchboard requires a cable turning section at one end to enclose the cables entering the switchboard.

The relays, resistances, retardation coils, condensers, etc., associated with the cord, operator's telephone, supervisor's and night alarm circuits are mounted in the rear of the board. The line relays and the line auxiliary signal circuit are mounted on a separate relay rack.

Provision is made for fusing all positional circuits in the rear of the sections. The line, trunk and other miscellaneous circuits are fused on a fuse board mounted on the relay rack.

The piling rail and keyshelf are covered with durable non-reflecting phenol fibre. The plug shelf is covered with hard rubber.

Capacity

The capacity of this switchboard is variable depending upon the requirements of a specific installation. Each job is engineered according to the conditions which prevail wherein the board is to be installed. These boards are suitable for offices having from 300 to 10,400 subscribers' lines. Where it is expected that the switchboard will reach a maximum of 4000 lines or more, the subscribers' line multiple is installed on an eight (8) panel basis and the toll and rural line multiple arranged on a six (6) panel basis. Boards installed in offices that will not exceed a capacity of 3000 lines have all multiple arranged on a six panel basis.

The 4000 line capacity board is provided with either 360 toll lines or 720 outgoing trunks.

The cord circuit capacities of the lower units are as follows:

Local Positions.....	17
Inward Toll Position.....	16
Outward Toll Position.....	10

Separate Trunk, Trouble and End positions can be provided to meet the requirements at the time of installation.

Information pertaining to the installation of this switchboard will be furnished upon request.

Distributing Frames

A main distributing frame is essential with any switchboard but in a multiple central office the importance of a properly designed main frame is manifold. Consideration must be given to the proper protection of all lines, accessibility of all terminals for the purpose of making cross connections, provision for future growth, and strength and durability.

The Western Electric design of main frames takes all these factors into consideration. The framework proper is rigidly constructed of steel and finished with aluminum paint. The protectors afford uniform protection to all lines while all terminals of both protectors and terminal strips are strong and accessible.

Intermediate distributing frames are not required with the No. 11 Switchboard.

SWITCHBOARDS—CENTRAL BATTERY MULTIPLE

(Continued)

Relay Rack

The relays for the line circuits are mounted on a separate relay rack associated with the main distributing frame.

Western Electric relay racks are constructed of steel bars, I-beams and angles, carefully designed to provide ample strength and preserve alignment. All metal work is given an aluminum finish.

Chief Operator's and Other Similar Desks

As providing suitable equipment for a chief operator enabling her to receive and originate calls with the subscribers it is customary to provide a chief operator's desk. In the case of large exchanges information desks and sometimes service observing desks are frequently desired.

The grade and finish of this equipment matches that of the switchboard with which it is used.

Testing Equipment

The Western Electric Company always recommends the adoption of testing equipment enabling a wire chief to keep an accurate check on the conditions of all line and switchboard circuits as well as insuring the prompt detection and location of all circuit troubles.

This equipment assumes different forms—i.e., a comprehensive type of wire chief's desk or a simple form of wire chief's turret suitable for mounting on a commercial desk as dictated by the desires of the telephone company.

Power Plant

A power plant for a multiple switchboard comprises—motor generator or rectifier charging equipment—power board—storage battery—ringing equipment—conduit and wiring, representing the heart of the entire exchange. Careful attention is given to ample capacity of all units as providing for the ultimate needs of the switchboard as well as the immediate needs.

All units for the Power Plant of a Western Electric switchboard are selected for efficiency and ability to perform satisfactorily for the entire period of expected life.

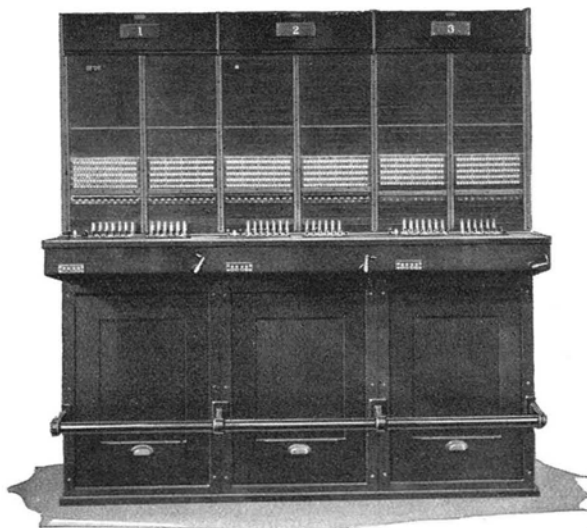
SWITCHBOARDS—CENTRAL BATTERY MULTIPLE**No. 12D Switchboard**

The No. 12D Switchboard can be made up of one or more sections

General. The Western Electric No. 12D Switchboard was developed to meet an increasing demand for a small central battery switchboard which could be installed at a low initial cost in exchanges which are now operating on a magneto or a non-multiple basis. It is adaptable particularly where the original installation consists of only a few positions and the estimated growth will be slow.

In the No. 12D Switchboard the engineers have specified the use of manual cord circuits. The reasons for this are obvious. Feature cord circuits are expensive in their first cost and are difficult to maintain due to the multiplicity of apparatus required.

With switchboards of this size, experience has proved that there is not sufficient gain in efficiency from a traffic standpoint to warrant the expense required for the inclusion of complicated feature cord circuits.

Capacity. The capacity of the No. 12D Switchboard is 600 central battery and 60 magneto lines, or 800 central battery and 80 magneto lines; depending upon whether a three or a four panel multiple layout is used.

DESCRIPTION OF SWITCHBOARDS

The No. 12D may serve entirely as a local board in full tributary offices, or as a combined local and toll board in partial tributaries or small toll centers. Where used as a local board in full tributary offices, all positions are equipped alike. Where used as a combined local and toll board in partial tributaries or in a small toll center, toll sections may be equipped as required.

Provision is made for single, two-party and four-party selective one or two-way ringing, employing either an individual cord circuit or a master ringing key.

The simplified arrangement and the small number of units which make up the equipment result in a low initial installation cost as well as minimum maintenance expense.

Features.

The principle features of the No. 12D Switchboard are:

1. Specially designed central battery subscribers' lines, eliminating the use of line and cut-off relays.
2. A fixed floor plan layout, of which a compact arrangement of the equipment is a part. By following this layout, the necessity for special technical treatment which is normally required for each installation, will be avoided. In addition, the plan permits the installation of as many as five positions in a room approximately 16' x 16'. This makes the equipment adaptable particularly in central offices located in a private residence.

3. Relatively few operating units to require adjustment. This feature results in more simple maintenance facilities.

SWITCHBOARDS—CENTRAL BATTERY MULTIPLE**No. 12D—Continued**

Switchboard Construction. Each section is an independent unit and consists of one operator's position. The framework is rigidly constructed of steel with all joints welded. This framework is coated with aluminum, rust-proof paint. Selected mahogany, thoroughly seasoned and kiln dried to prevent warping or cracking is used. The cabinet work is finished in walnut.

All wood joints are tongue and groove, thoroughly glued. All exposed surfaces are given a rich, durable finish, while the inner surfaces are coated with shellac in order to protect them against moisture.

The stile strips, which support the face equipment; the key mounting bars that hold the keys in place in the key shelf; and the relay mounting supports to which the relay mounting plates are attached are made of cold-drawn galvanized steel. Piano hinges extending the full length of the key shelves are used.

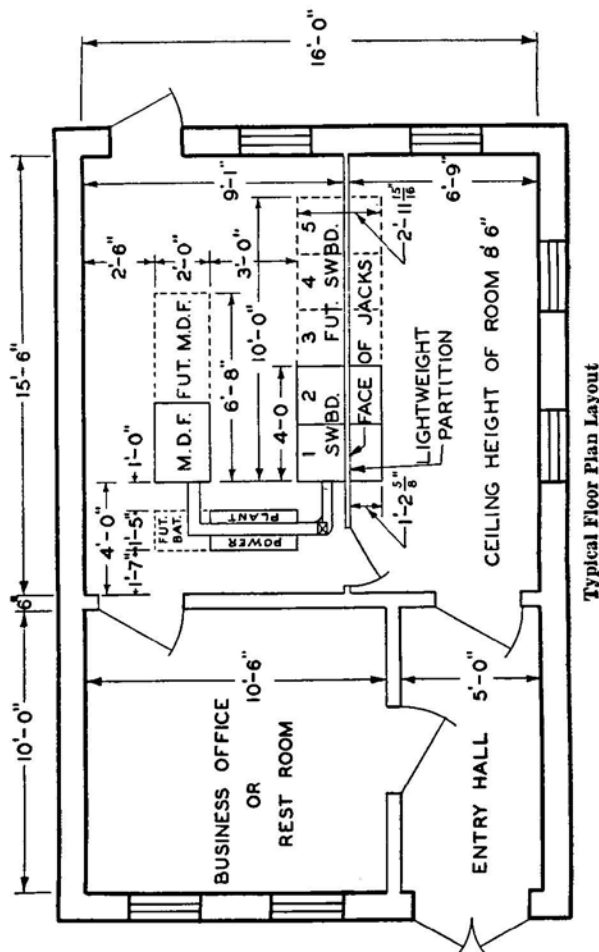

The end panels and the front panels that conceal the cords are removable. Removable rear doors allow free access to the back of the section.

The plug shelf is covered with durable, non-glare, semi-hard rubber. The piling rail and lamp rail are covered with black phenol fibre.

Positional Equipment. The No. 12D Switchboard is available in two types of positions; namely, toll, and combination local and rural.

The toll position is wired for and equipped with eight universal two-way ringing cord circuits, employing a master key where party line ringing is desired; and is arranged to accommodate a calculagraph at the right of the section.

SWITCHBOARDS—CENTRAL BATTERY MULTIPLE

No. 12D—Continued

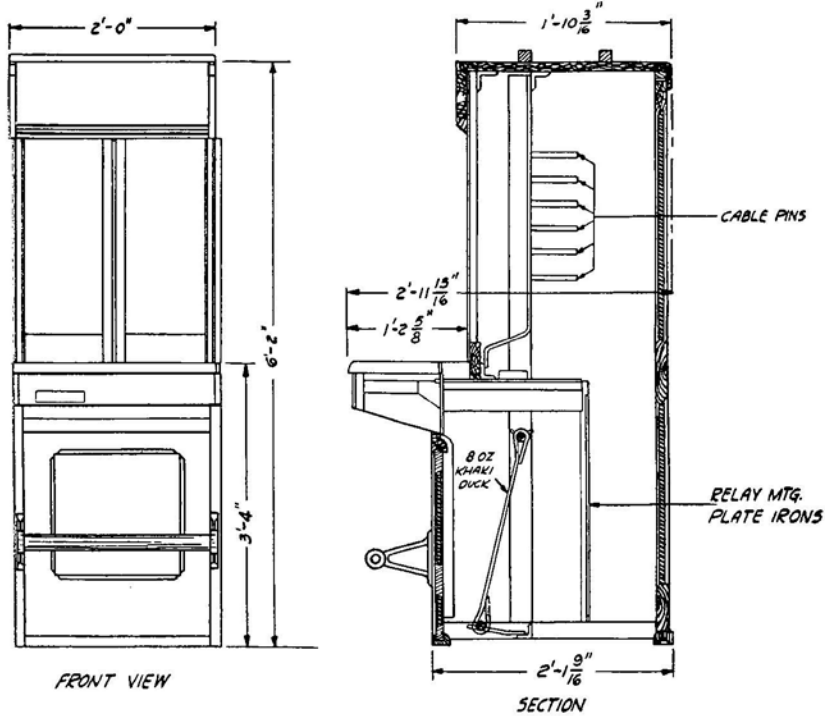

Dimensional Views of No. 12D Switchboard

The combined local and rural position is wired for 15 universal cord circuits using individual single party ringing keys or either individual party line ringing keys or a master key for party line ringing. Provision is made for coin collect keys although this feature is not ordinarily furnished. Normally thirteen pairs in each position are equipped. The first and fifteenth pairs are unequipped, in order to provide two cord circuits for future expansion.

CIRCUITS

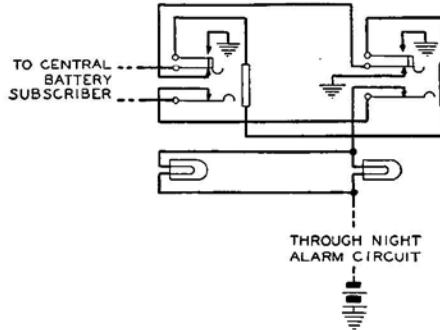

Central Battery Line Circuit

Central Battery Lines. The central battery subscriber lines in this board differ from those used in a number of other boards. This is due to the development of a new lamp, adaptable to a large voltage range, which will not burn out on a zero loop and which will give satisfactory illumination on a line having a resistance up to 800 ohms. Because of this lamp, it is possible to connect the line lamp in series with the line. The use of this lamp eliminates the usual line and cut-off relays.

SWITCHBOARDS—CENTRAL BATTERY MULTIPLE

No. 12D—Continued

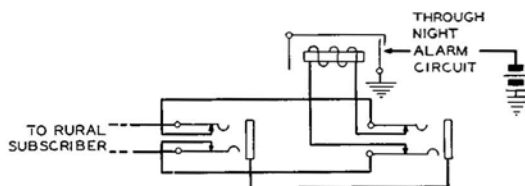

Magneto Line Circuit

Magneto Line. The magneto lines, which may be used interchangeably for toll, rural or ringdown trunks, are of the ringdown type; employing manually restored drops and cut-off jacks. These lines are arranged to be multipled throughout the switchboard.

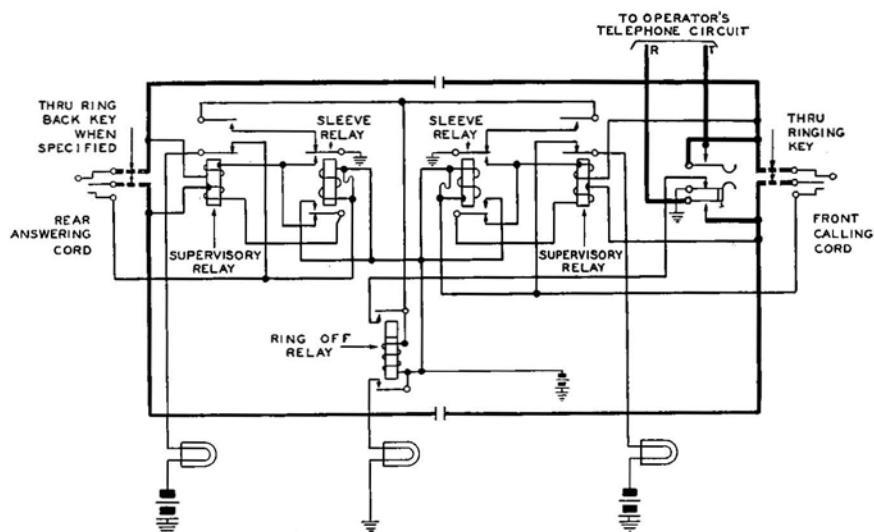

Universal Cord Circuit

Cord Circuits. The cord circuits are of the bridged-impedance, universal type which adapt themselves automatically to permit connections between two central battery, two magneto, or a magneto and a central battery line. They are of the manual ringing and listening type, and are arranged for full lamp supervision. Supervision on central battery connections is provided by the regular supervisory lamp associated with the answering and calling cord. Supervision on magneto connections is provided by a third lamp common to both cords. The cords are arranged for 48 volt transmission.

Miscellaneous. Any arrangement in which the line lamps on central battery lines are in series with the line, has always made the operation of a night alarm difficult, since the line leakage on a large number of lines connected in parallel may be sufficient at times to operate the alarm unintentionally. For the No. 12D board, however, this difficulty has been overcome by the use of a patented "Wheatstone Bridge" night alarm circuit. The usual night alarm release key is included in this circuit.

The operator's telephone circuit, in addition to its anti-sidetone feature provides for high impedance monitoring on all calls when the position monitoring key associated with this circuit is operated in conjunction with the cord circuit listening key.

A voltmeter test unit is mounted on a panel arranged for mounting in the switchboard jack field and can be furnished when desired. By means of the test circuit with which the panel is wired, the usual Ballistic test and tests for ground, crosses, insulation resistance, etc., can be made.

There is also available, and likewise assembled on a panel for mounting in the switchboard jack field, a test circuit consisting of several test jacks, test resistances and associated cords for patching and control purposes.

By means of this test circuit the following tests can be made:

Operate test of supervisory relays.
Release test of supervisory relays.
Operate test of sleeve relay.
Non-operate test of sleeve relay.

Operate test of magneto line drop.
Test of night alarm feature.
DC continuity test of cord circuit.

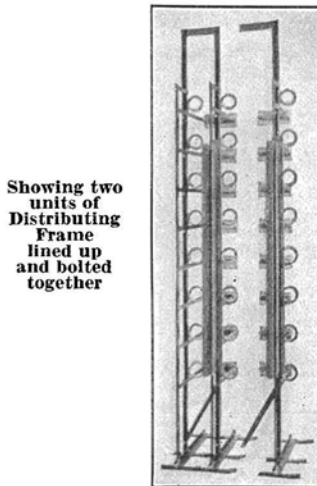
SWITCHBOARDS—CENTRAL BATTERY MULTIPLE**No. 12D—Continued**

Showing two units of Distributing Frame lined up and bolted together

One 100 line unit of Distributing Frame

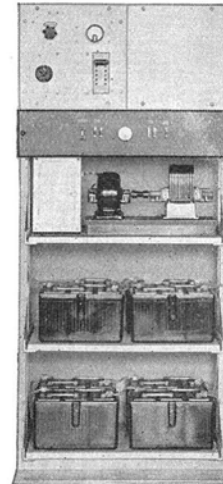

Front view of power equipment showing small motor driven magneto generator and one rectifier

MAIN DISTRIBUTING FRAME

The Main Distributing Frame is of the unit type arranged for floor mounting, and is especially adapted for small telephone central offices. The frame is rigidly constructed of steel bars and angles, securely bolted or welded together and is so designed that single verticals may be added as desired. The verticals are mounted on 8-inch centers.

Each unit is arranged on the vertical side for mounting 100 unit type Western Electric protectors on $\frac{1}{2}$ -inch centers. The horizontal side is arranged for eight shelves on which are mounted, between adjacent verticals, the required number of Western Electric No. 65 or similar type terminal strips.

The lines from the switchboard terminate on the protectors and the outside lines on terminal strips.

Rubber covered distributing rings are placed conveniently, thereby facilitating the running of jumper wires in a uniform, compact, and neat manner, without going through more than one ring or requiring more than one turn.

POWER PLANT

The power plant of the No. 12D Central Office equipment consists essentially of a 23-cell storage battery, charging indicator and one or two tungar rectifiers (for charging). There is also a small motor driven magneto generator, or a suitable wall mounted interrupter, for the ringing supply. Provision is made to include a second set of batteries for emergency purposes. Under normal conditions, the battery voltage will remain within the limit of 44 to 54 volts, with extreme limits of 40 to 56 volts.

The rectifier is controlled manually, and should be adjusted to supply the daily office load plus the losses of the battery, during the 24 hours of the day. A voltmeter is provided for reading the voltages of the battery.

The rectifier in addition to having a plug and jack arrangement for changing transformer taps, is equipped with a rheostat to permit close adjustment of the output.

Should the main power supply fail at any time, ringing current may be obtained from the hand generators which are standard equipment on the switchboard.

The following table gives the reserve in hours which will be obtained from one 50 or one 100 ampere hour battery or from two 100 ampere hour batteries in parallel:

Busy Hour Amperes	One 50 Ampere Hour Battery	One 100 Ampere Hour Battery	Two 100 Ampere Hour Batteries
2	28.0	53.0	—
3	17.5	33.5	—
4	12.5	24.5	53.0
5	9.0	18.5	41.5
6	7.5	15.0	33.5
7	6.3	12.5	28.0
8	5.3	10.5	24.5

In the above reserve figures, consideration has been given to the reduction of the battery capacity due to aging.

SWITCH HOOKS

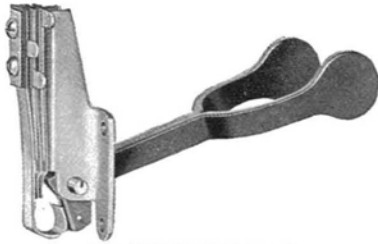

No. 143Y Switch Hook

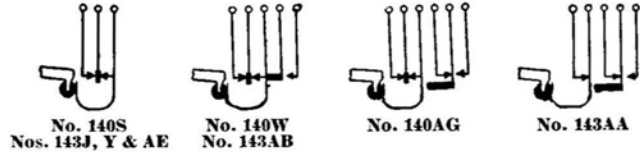

No. 140S
Nos. 143J, Y & AE

No. 140W
No. 143AB

No. 140AG

No. 143AA

Nos. 140 and 143 Types

The Nos. 140 and 143 Type Switch Hooks are simple, compact and self-contained. The switch hook lever is made of brass with black finish and is designed to withstand rough usage. The bracket is made of steel and is extremely rigid. The springs are of nickel silver and are backed up with brass stop springs. The movement of the lever is limited by stops, making it impossible for the springs to be damaged. The switch lever pivots on a fulcrum pin which is normally locked in position by means of a retaining spring. This pin may be readily removed with the fingers, when desired.

All iron and steel parts have an electro-galvanized finish to thoroughly protect them against rusting.

Mechanical contact is made between the lever and the tension spring through a hard rubber roller to minimize friction. All current carrying parts are insulated from the bracket.

Except for the No. 143AE these switch hooks are designed for use with standard hand receivers (Nos. 143 and 144).

The No. 140 Type Switch Hooks are intended for use in metal telephones (Nos. 1533 and 1553 Types) and, therefore, no escutcheons are provided.

The No. 143 Type Switch Hooks mount by means of four machine screws which pass through clearance holes in the escutcheon and thread into tapped holes in the switch hook bracket. Screws of suitable length for mounting in 1/2 inch woodwork are furnished unless otherwise specified.

Code Nos.	140S	140W	140AG	143J*	143Y	143AA	143AB	143AE‡
-----------	------	------	-------	-------	------	-------	-------	--------

* No. 143J is treated to resist action of moisture and fumes.

† Refer to spring contact arrangements above.

‡ No. 143AE is equipped with special lever for use with head band receiver only.



No. 141A Switch Hook

Code No.	Use and Description
141A	A nickel plated brass hook having a wood screw thread at one end and provided with a stop escutcheon. Overall length, 2 7/8 inches. Intended for use with No. 1002 and No. 1003 Type Hand Sets.

SWITCH HOOKS

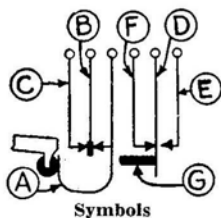

Switch Hook Replacement Parts

CONTACT SPRING PARTS

Switch Hook Code Numbers

Symbol	140S	140W	140AG	143J	143Y	143AA	143AB	143AE
A	P-121484	P-121484	P-121484	P-121484	P-145644	P-145644	P-145644	P-162207
B	P-145633	P-145633	P-145633	P-145633	P-145633	P-114095	P-145633	P-145633
C	P-114097	P-114097	P-114097	P-114097	P-114097	P-114097	P-114097
D	P-114098	P-145831	P-145827	P-145825
E	P-114097	P-114095	P-114095	P-114097
F	P-114095	P-114095

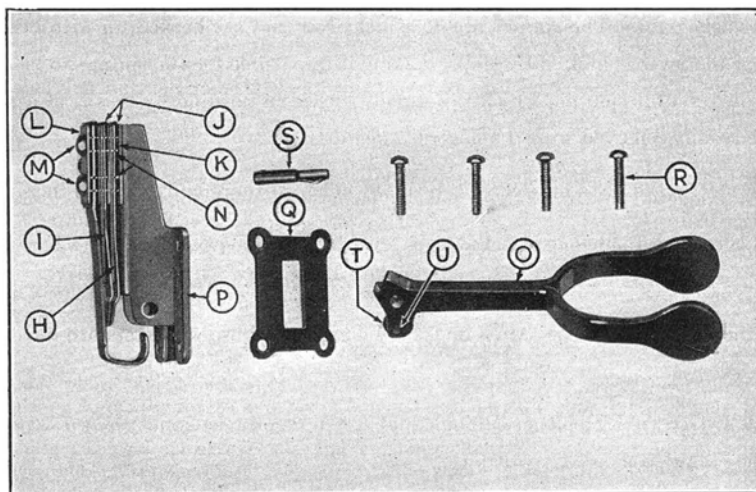

Sym- bol	Switch Hook Code Numbers								
	140S	140W	140AG	143J	143Y	143AA	143AB	143AE	
G	Spring Separator	P- 44454	P-106219	P-106219	P- 44454	
H	Stop Spring	P-112938	P-112938	P-112938	P-112937	P-112692	P-112937	P-112937	
I	Stop Spring	P-112693	P-112693 (2)	P-112693 (3)	P-112693	P-112692	P-112694 (2)	P-112692 (2)	
J	Insulators	P- 44448 (4)	P- 44448 (5)	P- 44448 (7)	P- 44448 (4)	P- 44448 (4)	P- 44448 (6)	P- 44448 (5)	
K	Steel Spacers	P-157542 (4)	P-157542 (5)	P-157542 (7)	P-157542 (4)	P-157542 (4)	P-157542 (9)	P-157542 (5)	
L	Steel Spacer	P-157541	P-157541	P-157541	P-157541	P-157541	P-157541	P-157541	
M	R.H.M. Screw	P-147761 (2)	P-157544 (2)	P-114035 (2)	P-147761 (2)	P-147761 (2)	P-114035 (2)	P-157544 (2)	
N	Bushings	P-139186 (2)	P-129907 (2)	P-111760 (2)	P-139186 (2)	P-139186 (2)	P-157547 (2)	P-129907 (2)	
O	Switchhook	P-123514	P-123514	P-123514	P-123514	P-123514	P-123514	P-139256	
P	Bracket and Springs, Complete	P-145648	P-145812	P-161134	P-145802	P-145646	P-145806	P-145807	
Q	Escutcheon	P-139277	P-136748	P-136748	P-136748	
R	Mtg. Screws	P- 38335 (4)	P- 38335 (4)	P- 38335 (4)	P-107892 (4)	P- 40830 (4)	P- 40830 (4)	P- 40830 (4)	
S	Fulcrum Pin	P-218066	P-218066	P-218066	P-218066	P-218066	P-218066	P-218066	
T	Roller and Rivet and Sleeve	P-128282	P-128282	P-128282	P-128282	P-128282	P-128282	P-128282	
U-1		P-128283	P-128283	P-128283	P-128283	P-128283	P-128283	P-128283	
U-2		P-111165	P-111165	P-111165	P-111165	P-111165	P-111165	P-111165	

Note. Numbers in parentheses indicate total number of parts required.

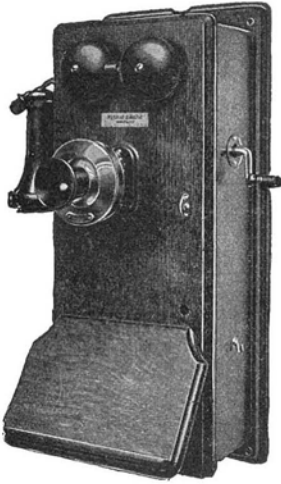
TELEPHONES—GENERAL**Wall Telephone Magneto Type****Wall Telephone
Central Battery Dial Type****Handset Telephone
Central Battery Type**

Western Electric telephones can be relied upon to give satisfactory service with minimum maintenance. Our extensive experience in the manufacture of telephone equipment for over half a century enables us to offer equipment which has proved its efficiency and reliability under most severe conditions. Through scientific design, careful construction and the use of only the best materials and workmanship, Western Electric telephone apparatus is recognized by the leading telephone authorities throughout the world as standard.

Our large output enables us to purchase raw materials under rigid specifications in large quantities at the lowest market prices. This, together with unequalled manufacturing facilities, makes it possible for us to offer standard telephones at reasonable prices. Every telephone and, in fact, every part is subject to a rigid inspection, both in the raw material and during manufacture, as well as before shipment.

There is a Western Electric telephone which will satisfactorily meet any standard service condition, the telephones listed on the following pages being considered as meeting all usual requirements. For special requirements, we have special telephones. Should special conditions be met, which are not already covered by existing apparatus, your problem will be given immediate and cheerful attention by our engineers.

DEFINITIONS OF GENERAL TELEPHONE TERMS

The following definitions of the terms used in connection with the apparatus in this catalog may be of interest and helpful in selecting the instruments best suited to various conditions or requirements.

TELEPHONE LINES

Grounded Lines. A grounded telephone line or system consists of only one wire, the ground being used for the return circuit—hence, the term “grounded line.”

Grounded lines give fairly good results, when properly constructed, provided there are no electric light, power or trolley wires in the immediate vicinity. The presence of such power wires is likely to cause objectionable humming and buzzing in the receivers, when the line is in use. Grounded lines are also subject to “cross talk”; that is, a telephone conversation on one line is liable to be heard in the telephones on adjacent lines. These objectionable features of a grounded line exist because the single wire of a grounded circuit cannot be transposed to overcome inductive influences from other circuits.

Metallic Lines. A metallic line is one consisting of two line wires, the ground not being used in this instance to complete the circuit. Metallic lines, under almost all conditions, are the most satisfactory to maintain and operate and are almost universally used, grounded lines being very rarely considered when high-class service is required.

TELEPHONES—GENERAL

Definitions of General Telephone Terms—Continued

Bridging Lines. Practically all telephones in present day use are known as "bridging telephones." These telephones are connected in parallel across the line wires, when used on a metallic circuit, or from the single line wire to the ground, when used on a grounded line.

Series Line—Magneto. Early in the development of the telephone art, magneto telephones were connected in series—like telegraph instruments are connected in a telegraph line. It was later found that the voice currents by passing through all the ringers connected in the line were quite seriously impeded and lost much of their strength, thus making it impractical or impossible to telephone over long distances or to place large numbers of telephones on one line and, at the same time, secure satisfactory service. As mentioned above, nearly all telephones in present day use are bridging, the use of series apparatus being discouraged, except for necessary replacement purposes.

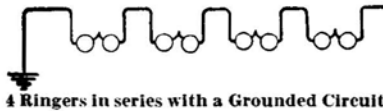
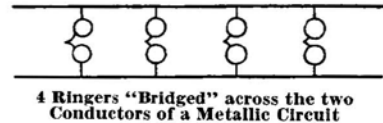
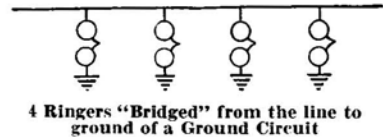

TELEPHONE SYSTEMS

There are two general classes of manually operated telephone exchange systems in present day use; namely "Magneto" (sometimes called "local battery") and "Central Battery" (sometimes called "common battery" or "central energy"). These two systems differ principally in the details of operation, that is, in the method of signalling or calling the other telephones and "central" and in the method of furnishing current for talking. The use of the central battery system is practical in cases where the telephone lines are comparatively short and such systems are therefore usually used in towns where 300 or more telephones are located within 3 or 4 miles of the exchange. Central Battery (C.B.) systems are also operated by industrial concerns using a large number of telephones within a comparatively small area.

Magneto Systems. In magneto systems, the telephone user signals or calls the exchange or other telephones on the same line by turning the crank of a magneto generator, the current thus generated causing a signal to be displayed or sounded in the central office (or exchange) or the ringers of the other telephones on the line to ring.

In magneto systems, the current for talking is usually furnished by two or three dry cells, either located inside the telephone itself (in the case of a wall telephone) or nearby on a shelf or in a battery box (in the case of a desk telephone).

Central Battery Systems. In manual central battery systems, the exchange is signalled by merely lifting the receiver from the hook on the telephone. In these systems, the telephones cannot be rung except from the exchange as they are not equipped with magneto generators.

In central battery systems, the battery which supplies current for talking, as the name implies, is located at the central office or exchange, one battery usually supplying all the telephones connected to the exchange.

Central Battery Signalling—Local Battery Talking. In this system, as the name implies, central battery signalling is employed but current for talking is supplied by dry cells as in magneto telephones. Telephones of this type are used only on long central battery lines where the current from the central office battery would be too weak (due to the high line resistance) to give the grade of transmission desired.

Private Lines. These are lines (either grounded or metallic) the telephones on which have no connection with telephones other than those on that particular line; that is, they are not connected to a switchboard.

Private lines are principally used by railroads, mines and for farm or rural lines.

Standard bridging magneto telephones are usually employed for private line work, although special designs of telephones are available for special classes of service such as for street railway telephone systems, mine telephone systems, etc.

Private lines, as above described, should not be confused with individual or direct lines, later described, which refer to exchange lines, equipped with only one telephone.

TELEPHONES—GENERAL**Definitions of General Telephone Terms—Continued****EXCHANGE LINES**

Individual Lines. An individual or direct line may be metallic or grounded and has but one telephone connected to it.

Party Lines. A party line is one having two or more telephones connected to it. The number of telephones which can be connected to a party line varies all the way from two to forty or fifty, depending entirely on the ringing system employed, the character of service desired and the local conditions encountered.

GENERATOR RINGING CURRENTS

Alternating Current. At each revolution of the armature of an alternating current magneto generator or a bipolar ringing machine, current of one polarity is generated the first half of the revolution and current of the opposite polarity of the other half of the revolution; this current rising from a zero value to maximum and then dropping again to zero, then building up in the opposite direction to the maximum and again dying out to zero as the cycle is completed. This is an alternating current. For ringing telephone bells, an average frequency of 16 to 20 cycles per second (in other words, 16 to 20 revolutions of the armature) has been found to give the best results.

Pulsating Current. A generator arranged to produce "pulsating" ringing current is in general the same as an alternating current one except that a two segment commutator and two brushes are added. These are arranged so that during one-half of the cycle, positive pulsating current is delivered to the positive brush and during the other half of the cycle, no current is delivered to that brush (or else it is grounded). Negative pulsating current is delivered to the negative brush in the same manner.

Superimposed Ringing Current. "Superimposed" current is obtained by connecting a storage battery in series with a generator delivering alternating current. The storage battery reduces the A.C. wave during one-half of each cycle and increases it the other half. This current is used for operating ringers selectively in the same manner as pulsating current. Ringers adjusted for operation on pulsating current will operate satisfactorily on superimposed current.

RINGERS

Alternating Current and Pulsating Current. Ringers intended for operation on pulsating current are provided with a bias spring which normally holds the armature so that it is free to move in one direction only. In view of this, the ringer will respond to pulsating current of one polarity, but will not respond to pulsating current of the opposite polarity. In addition to the bias spring, ringers designed for operation on pulsating current have a stop screw for limiting the movement of the armature, thereby facilitating the pulsating current adjustment.

The presence of a bias spring does not necessarily indicate that the ringer is adjusted for operation on pulsating current, as the bias spring is frequently used to prevent an alternating current ringer from tapping, due to inductive disturbances on the line, and in some cases to prevent operation on pulsating current. Ringers designed for operating on pulsating current, may be operated on alternating current.

TELEPHONES—GENERAL**Transmission Circuits (“Talking Circuits”)**

Western Electric telephones are equipped with a number of different types of transmission circuits, four of which are listed below.

Type	One of the Various Transmitters Used for this Service	Receivers	Induction Coil	One Telephone Employing this Type of Transmission Circuits
A Central Battery	323	144	46	1533A
B Local Battery	323	144	13	1317N
C Local Battery Talking Central Battery Signalling	323	144	13	1533Y
D Series Central Battery	323	171 (“Magnetless” receiver)	None	1533K

The circuit designated “A” in the above table is the Western Electric “standard” for Central Battery Service. This is the highest efficiency circuit for long line service and is used in all “standard” Western Electric central battery telephones.

The circuit “B” is the Western Electric “standard” local battery circuit and is used in practically all Western Electric magneto telephones. This is the highest efficiency local battery circuit that has been developed up to the present time.

The circuit “C” is used on central battery lines which are so long that the current from the central office battery is not sufficient to provide satisfactory transmission. This circuit is the same as the standard local battery circuit except that no generator is employed and that a condenser is used, as in the standard central battery circuit, to prevent the flow of current from the central office battery through the ringer. The conditions under which this circuit is required are exceptional and it is therefore considered special.

In the circuit “D” the transmitter and receiver are connected in series across the line, no induction coil being employed. The receiver is the “magnetless” type, i.e., it has no permanent magnet. The transmission obtained with this circuit is satisfactory on short central battery lines, i.e., lines not exceeding two miles in length (using 22 B. & S. Gauge Cable) but on lines longer than this the transmission efficiency of this circuit is appreciably lower than that of circuit “A.” In view of the fact that circuit “A” gives the best results on both short and long lines its use is recommended in preference to circuit “C.”

The following are diagrams of telephones employing the above transmission circuits.

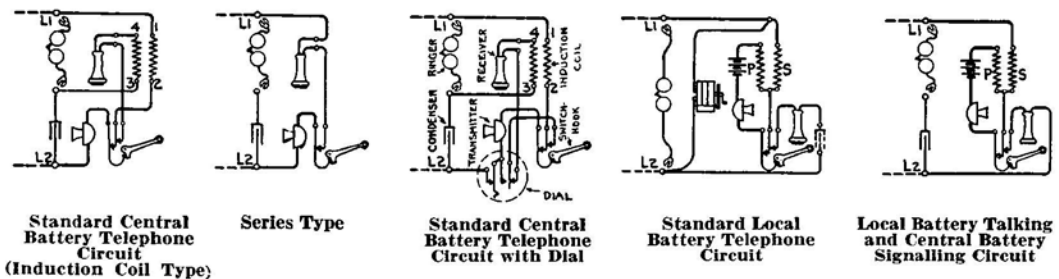

TELEPHONES—MAGNETO

Magneto Telephone Systems

Service. The number of magneto telephones that can be connected on the same line varies, ranging from 1 to 40 or more. However, a line having more than 20 or 30 telephones connected to it, is usually very unsatisfactory from a service standpoint, except in a case of necessity or for temporary service, the reason for this being that a line having so many telephones is found to be in use almost continuously, the bells ringing at very frequent intervals and the users almost sure to be "rung in the ears" or otherwise interrupted during a telephone conversation.

The following definitions of what may be considered a lightly loaded, medium or heavily loaded line are submitted with the thought that the limits are conservative enough so that under all but extreme conditions the figures given can be relied upon. In the following pages will be found a complete catalog of telephones and opposite each a statement as to the maximum line load under which that telephone will give best service.

The telephone lines referred to are assumed to be well insulated, free from high resistance joints, and constructed of iron wire not smaller than No. 14 B.W.G. Gauge.

Light Loaded Lines. A light loaded line is one less than 15 miles in length, and not equipped with more than twelve telephones.

Medium Loaded Lines. A medium loaded line is one between 10 and 30 miles in length and equipped with from 10 to 30 telephones.

Heavy Loaded Lines. A heavy loaded line is one up to 40 or 50 miles long or equipped with up to 40 telephones. Lines loaded with this number of telephones are rapidly going out of use or are being broken up into shorter lines or equipped with fewer telephones. Lines of this length, loaded with this great number of telephones, should be discouraged in all cases except in cases of extreme necessity or for temporary service.

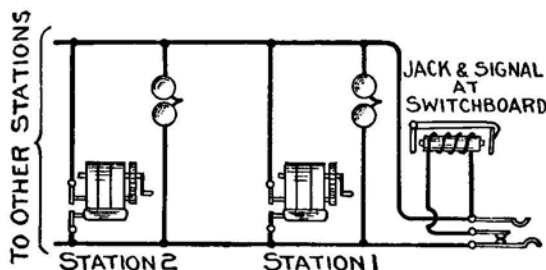

Code Ringing—Magneto Line

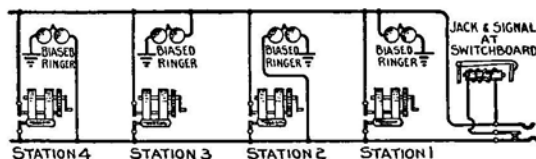

Pulsating Current 4 Party Selective Signalling—Magneto Systems

Code Ringing Non-Selective

The most universal method of signalling parties on a magneto telephone line is by code ringing. In the code ringing system, rings of different codes are employed for signalling each telephone, such as 2 short, 3 shorts, or 1 long and a short, 2 long and 2 short rings or other combinations. This system has the advantage that it can be used with a large number of telephones on the same line, any number in fact, the number which can be placed on a line depending on conditions other than ringing. Again, it is a simple system, as no special apparatus has to be used, the undesirable feature being that when one telephone is called, all the other telephones on the line are also rung, making it necessary for the user to count every signal in order to know when he is being called. This system is most commonly used on rural or farmers' telephone lines.

TELEPHONES—MAGNETO

Magneto Telephone Systems

FOUR PARTY SELECTIVE—EMPLOYING PULSATING CURRENT

In this system, any one of four telephones on the same line may be rung without ringing the others. This is accomplished by sending positive or negative pulsating current out over either side of the line (through the ringers connected to that side of the line), to ground. In other words, the central office operator connects either the positive or the negative terminal of the ringing generator to either of the two line wires and as one terminal of the generator is permanently grounded a return circuit is established through the ringers. The ringers used in this service are equipped with bias springs and armature stop screws and are so adjusted that they will ring when negative pulsating current is connected to the terminal nearest the bias spring and will not ring when positive pulsating current is connected to this terminal. Two of these ringers are connected from each side of the line to ground, the ringers on the same side of the line being connected differently; in other words, one ringer is connected with its negative terminal (the terminal nearest the bias spring) to the line while the other ringer on the same side of the line has its positive terminal (the terminal opposite the bias spring) connected to the line. In view of this, it will be seen that when pulsating current is sent out over one side of the line, through the ringers, to ground only one of the two ringers will respond, depending on the polarity of the ringing current.

The generator (No. 22E) used in these telephones operates the central office drop but does not operate the ringers on the line.

CENTRAL OFFICE SELECTIVE SIGNALLING

Telephones for this service are so wired that the switchboard drop or signal may be operated "secretly," that is without ringing the bells of any of the other telephones on the same line. This is accomplished by pressing a button while turning the generator crank. We are prepared to furnish three different telephones, each equipped with a different type of push button, which performs similar service, but in a slightly different manner, the results, however, being much the same.

Central Office Selective Signalling the 1006A Push Button and A.C. Generator. Operating this push button connects the generator to one side of the line and to the ground. These telephones can be used only on metallic lines and where the switchboard drop is singly wound and has one terminal of its winding connected (or arranged so that it can be connected) to ground.

When the generator is operated without pressing the push button, all the other telephones on the line are rung without operating the drop at the exchange. When the push button is pressed when turning the generator crank, the drop is "thrown" (operated) but none of the other telephone ringers on the line are rung.

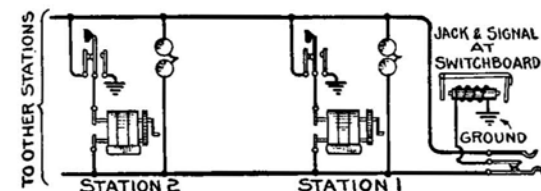

Wiring of Telephones and Switchboard Apparatus when No. 1006A Push Buttons Are Used

CONDENSERS—"LISTENING IN" TROUBLE

On rural lines trouble is frequently experienced, due to receivers being carelessly left off the switchhook or due to parties "listening in," whenever their telephone rings, regardless of whether or not the call is for them. When a number of receivers are off the hook it is usually impossible to ring as they form a lower resistance path for the ringing current than the ringers. To overcome this it is customary to use telephones equipped with a condenser wired in series with the receiver. (The presence of the condenser does not appreciably affect the receiver circuit as far as voice currents are concerned, but it increases the resistance to ringing current to such an extent that the ringers receive the amount of current they require for operation.)

Practically all of our magneto telephones, arranged for code ringing, have terminals provided so that a condenser may be readily connected in the receiver circuit at any time and certain telephones are equipped with a condenser in the receiver circuit as standard. (See descriptive list of telephones.)

TELEPHONES—MAGNETO

No. 1317 Type Telephone Set
3 Cell, Closed View

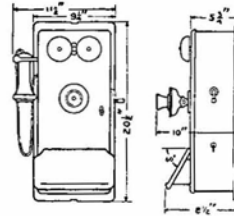

Dimensions of 3 Cell
No. 1317 Sets

No. 1317 Type Magneto Telephones**GENERAL DESCRIPTION**

The No. 1317 Type Telephone represents the highest development attained in magneto telephone design and construction. It has been standard with the Western Electric Company for more than a decade, and its high efficiency, reliability and long life have been thoroughly proven by the hundreds of thousands in service.

2 and 3 Cell Types

The standard No. 1317 Type Telephone Set operates on 3 dry cells and is equipped with a No. 48 Type (5 bar) Generator. This set is designed to meet the exacting requirements of heavily loaded lines.

A smaller set of the same type using the same circuits and equipment except the generator and operating on 2 dry cells is available for medium loaded lines. The No. 50 Type (3 bar) Generator is used in this set.

Although both sets are almost identical, the additional power of the 3 cell type gives greater transmission advantages and the two cell type should only be considered when circuit conditions are favorable.

Woodwork and Finish. The cabinet is made of quarter sawed oak and given three coats of high-grade varnish rubbed down by hand. Unexposed surfaces of the telephone are also given a protective finish so as to prevent warping.

Wiring. All terminals including those for the transmitter, receiver, cord, line wires, etc., are plainly marked so that there can be no possible mistake when making connections. The various cords, such as those of the transmitter and receiver and the flexible leads running to the condenser are all furnished with cord tips.

A complete and explanatory circuit label is pasted on the inside of the door of each telephone in addition to which a booklet is furnished giving complete instructions for installation and maintenance.

Metal Finish. The transmitter bracket, gongs, switch hook, generator, crank and lock escutcheon are given an extremely durable and pleasing black finish.

Adjustment. These telephones are carefully adjusted in the factory, and should, therefore, be satisfactory for service as received by the customer unless unusual service conditions should be encountered, in which case only the ringer will require readjustment. The adjustment of the ringer is a very simple matter and instructions furnished in the booklet are so clear that no difficulty will be encountered.

TELEPHONES—MAGNETO

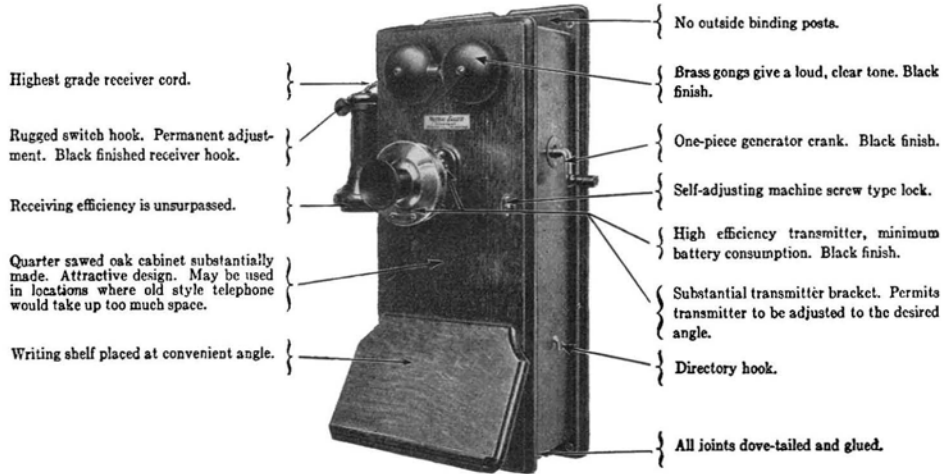

No. 1317 Magneto Type

NO. 1317 THREE-CELL TYPE

Code No.	Ringer		Generator Code No.	Condenser Code No.	—Class of Signal Service—		Line Conditions as Regards Load
	Code No.	Resistance, Ohms			Telephone to Central Office	Central Office to Telephone	
1317AH	38AG	1000	22A	Code	Code	Lightly
1317N	38FG	1600	48A	Code	Code	Medium
1317R	38FG	1600	48A	149A	Code	Code	Medium
1317P	38BG	2500	48A	Code	Code	Heavily
1317S	38BG	2500	48A	149A	Code	Code	Heavily
1317BA	38FG	1600	48A	* C.O. Selective	Code	Medium

NO. 1317C TWO-CELL TYPE

1317CH	53AG	1000	22BA	Code	Code	Lightly
1317CN	53FG	1600	50F	Code	Code	Medium
1317CR	53FG	1600	50F	149A	Code	Code	Medium
1317CP	53BG	2500	50F	Code	Code	Heavily
1317CS	53BG	2500	50F	149A	Code	Code	Heavily

Two or three dry batteries are required but must be ordered separately. In addition to the above-mentioned apparatus, these 1317-Type Telephones are equipped with the following:

Transmitter	323	Induction Coil	No. 13
Receiver	144	Transmitter Bracket	No. 8A
Receiver Cord	No. 521 (30 ins.)	Switch-hook	No. 143Y
Transmitter Cord	T1A (6 ins.)		

* Equipped with No. 1006A Push Button. Telephone user can signal central office secretly or not, as desired, and can signal other parties on the same line by code ringing (see pages describing "Magneto Telephones—Definition of Terms").

TELEPHONES—MAGNETO

No. 1317 Type Magneto Telephones—Continued

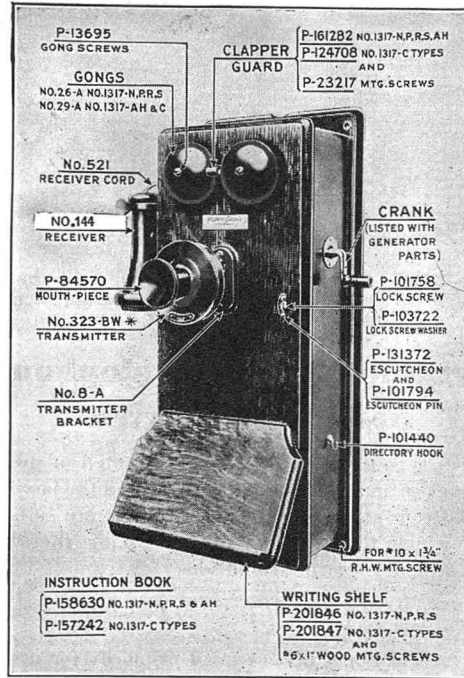

No. 1317 Telephone Closed View

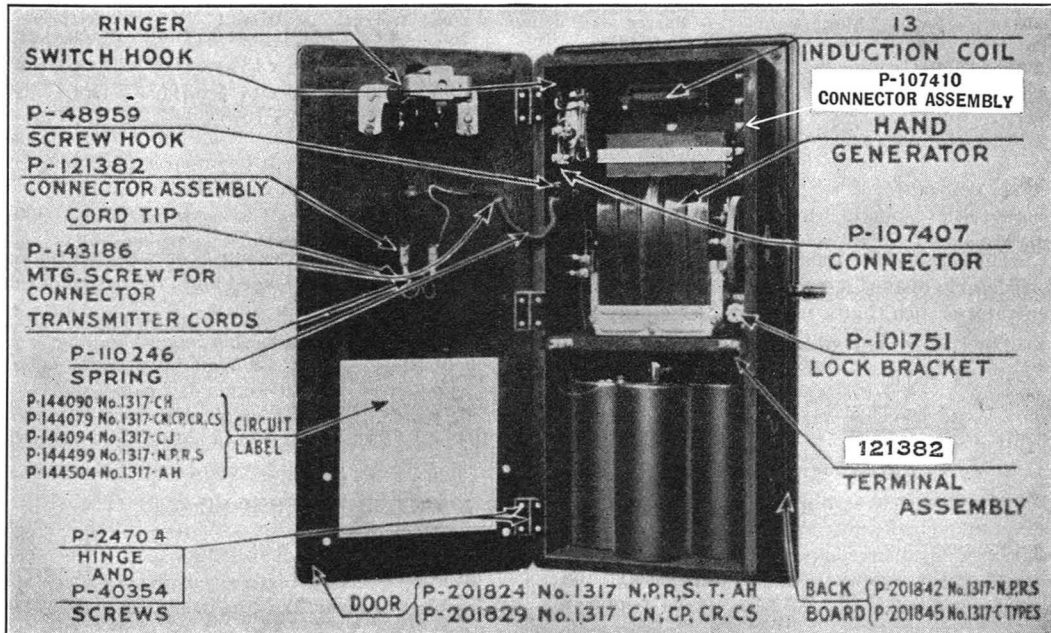

No. 1317 Telephone Open View

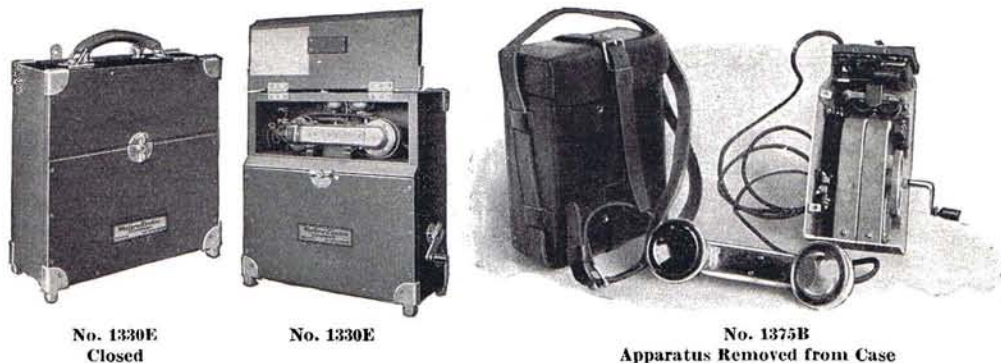
TELEPHONES—MAGNETO**Portable Magneto Telephones****NOS. 1330 AND 1331 TYPES**

These are complete hand set type magneto telephones mounted in substantial wooden cases. They are primarily for use in railway service and are designed to withstand the jarring and rough handling incident to train service. In addition to railway service these telephones are suitable for any service where an extremely substantial type of portable telephone is required. While these telephones are not waterproof they are designed to withstand ordinary weather conditions.

The No. 1330F is equipped with a six-foot waterproof cord and No. 146 Plug for connecting it to a telephone line through a No. 186 Pole Jack.

The Nos. 1330E and 1331E Telephones are intended primarily for use where connection to the line will be made with a line pole.

The No. 1330 Type Telephones are for use on heavily loaded lines.

The No. 1331 Type Telephones are for use on light loaded lines.

Code No.	Hand Set No.	Plug No.	Plug Cord No.	Ringer or Buzzer No.	Ohms	Condenser No.	Generator No.	Approx. Weight, Lbs.	Overall Dimensions	Battery Used*
1330E	1001C	32BG	2500	149A	48A	28	12½ x 13½ x 5¼	2 Dry Cells*
1330F	1001C	146	509	32BG	2500	48A	28	12½ x 13½ x 5¼	2 Dry Cells*
1331E	1001C	3B	2500	149A	22A	17	11½ x 10½ x 4¾	2 No. 790*

Each set also contains a No. 29 Induction Coil.

NO. 1375 TYPE

The No. 1375B is especially adapted for use in cases where the telephone user must carry the telephone considerable distances. While it is primarily intended for use on moderately loaded lines, the design of the generator is such that it may be satisfactorily operated on heavily loaded lines.

The case is made of high grade leather and is designed to withstand considerable rough handling.

Code No.	Hand Set No.	Buzzer No.	Ohms	Generator	Ind. Coil	Approx. Weight Lbs.	Overall Dimensions	Battery Used
1375B	1001H	5A	2150	29E	31	10½	9¾ x 7¼ x 4¼	1 No. 703 Eveready*

REPLACEMENT PARTS FOR NO. 1375B TELEPHONE

Leather case only.....	P-139726	Generator mounting screws.....	P-123826
Case mounting screws.....	P-117156	Top wood block only.....	P-233712
Aluminum frame.....	P-141455	Line binding posts.....	P-122930
Circuit Label.....	P-114789		

* Batteries are not included in the code number of the set.

TELEPHONES—MAGNETO**Linemen's Portable Telephone Set**

No. 1526B Telephone Set,
minus shoulder strap

The No. 1526B Telephone Set is a complete portable magneto telephone. It is of rugged construction and designed to withstand jarring and rough handling. Overall dimensions: $7\frac{1}{2}''$ x $10\frac{9}{16}''$ x $5\frac{1}{16}''$.

Features incorporated in this set are as follows: the cover is bevel-fitted to improve the water-proofed qualities of the set; the transmitter is designed to exclude moisture and rain; the R2AJ Cord practically seals the cord hole in the case of the 562A Receiver.

A shoulder carrying strap is furnished with each set.

This telephone set consists of the following apparatus:

- | | |
|------------------------|---|
| 1 No. 398A Transmitter | 1 No. 526B Subscriber's Set containing: |
| 1 No. 562A Receiver | 1 No. 29G Generator |
| 1 No. R2AJ Cord | 1 No. 32 Induction Coil |
| | 2 No. T1A Cords (6'' Long) |

Two No. 714 Eveready Batteries are required, but not furnished.

Mine Telephones**General**

Since the workings of a mine necessarily are remotely located from the management, mine telephones are essential to successful operation. Reports of conditions may be obtained and orders given promptly by telephone with definite assurance that these messages have been received and understood. The time and money which the telephone saves daily under ordinary conditions are indeed large but in emergencies the saving of lives and property which the telephone may effect is of inestimable value.

Mine Laws

That the Legislatures of many of the States have made the installation of mine telephones and signals a requirement for mine operation is in itself sufficient endorsement of their usefulness. Those farsighted operators who so quickly and wisely responded to these demands are realizing the benefits of the increased operating efficiency that they effect in their mines along with the insurance against loss of life which was the primary object of the legislative acts.

MINE TELEPHONE SYSTEMS

In the Superintendent's office, engine house and other dry and protected parts of the Plant which should have communication with each other and the mine, the use of standard wall and desk type magneto telephones is recommended.

For use in mines where explosive gas is present the Western Electric Company has developed a telephone set which in the words of the United States Bureau of Mines "is permissible for use in mines or other locations where methane or other explosive gases or coal dust are or are likely to be present in dangerous proportions." This is the No. 1536E Telephone Set, hereinafter described in detail.

For use at exposed stations above ground and at stations below ground where there is no danger of explosive gases, the No. 1336 Type Telephone Set is recommended.

In cases where all the telephones of the system are connected to a single line (party line) the telephone used should be designed for use on heavily loaded lines—for example.

No. 1536E Telephones for service below ground where there is danger from explosive gases.

No. 1336J Telephones for service below ground where there is no danger from explosive gases and in exposed locations above ground.

No. 1317S Telephone (wall type) (5 bar generator) for service above ground in unexposed locations.

In cases where it is warranted by the size of the plant, the preferable arrangement is to employ a number of lines and a switchboard, instead of a party line. These lines may each have a number of telephones connected to them but the most satisfactory arrangement is to have the most important telephones of the system, for example the engine room telephone and the Superintendent's telephone, connected to individual lines. In addition to greater facility in handling calls the use of a switchboard has a number of advantages, an important one being that in case one of the lines should become broken or crossed, it will not tie up the rest of the system until the trouble is cleared.

TELEPHONES—MAGNETO**Mine Telephones—Continued****1336 Type Mine Telephone**

In cases where a switchboard is employed, the telephones below ground should be of the No. 1336 or 1536 Type as required but the lines above ground may be equipped with telephones having three bar generators if there are only a very few stations on each line. Sets recommended for such conditions are the No. 1317AH (wall type) and a 315H subscriber set with a hand telephone set for desk use.

No. 1336 Type Telephones

Briefly, these are metal case magneto telephones having all apparatus and parts treated to resist the action of moisture. They are primarily designed for use on heavily loaded lines where code ringing is employed and, while they are intended chiefly for mine service where danger from explosive gases is not present, they are also recommended for outdoor use.

Moisture-proofing. Experience has shown that moisture will condense on the inside surfaces of mine telephones regardless of whether or not they are of so called "Air Tight" construction. In view of this, the practice of employing gaskets, stuffing boxes, etc., was abandoned a number of years ago in favor of the design illustrated by the No. 1336 Type. In this design small openings are provided which permit air to circulate through the telephone without exposing it to the chance of trouble due to the entrance of foreign material. An opening is also provided so that water may drain off instead of remaining in the telephone. All apparatus and parts are specially treated so that they will not be injured by moisture or fumes, and in addition the telephone is so made that the presence of moisture will not interfere with signalling or transmission. The terminals of the apparatus are imbedded in insulating compound so that they cannot be short circuited even though the apparatus is wet. The telephone is wired with heavy stranded copper wire having rubber insulation and a braiding.

Dry Cells. Two standard size dry cells are required for each telephone to furnish current for talking.

Two special cartons, impregnated with moisture-proofing compound, are furnished with each No. 1336 Type Telephone. These are to be substituted for the standard cartons furnished on the dry cells. These cartons resist the action of any moisture that may form on the inside of the case and prevent current leakage and rapid deterioration.

Case. The box, outer door, inner door and gong hood are of cast iron heavily coated with a rust resisting finish. When the outer door is closed only the metal transmitter mouthpiece, receiver, receiver cord and the generator handle are exposed. When the outer door is closed these parts are protected from mechanical injury. When using this telephone it is, of course, evident that only the outer door need be opened.

Entrance for Line Wires. The line wires may be brought in either at the top or the bottom of the case. A short length of pipe is screwed into the top of the case and is covered with a pipe cap. This cap prevents water running into the set by following the line wires. In case the line wire is to be run to the telephone in pipe (conduit) no difficulty will be encountered in joining the conduit to the telephone as the wire entrance hole at the bottom as well as the top of the case is tapped.

Mounting. Wrought iron mounting bars are secured to the back of the case. The upper end of these have "pear" shaped holes, and with this arrangement the telephone can be readily mounted by one man and without any danger of damaging it. This is accomplished by driving two lag screws into the mounting surface until their heads project about $\frac{1}{2}$ inch. The telephone may then be hung upon these mounting screws (the heads of the lag screws will pass through the large end of the "pear" shaped holes) after which the lower mounting screws may be driven into place through the holes in the lower end of the mounting bars. Wrought iron mounting bars are employed as they are less subject to breakage than if lugs were cast on the case.

TELEPHONES—MAGNETO

Mine Telephones—Continued

NO. 1536 TYPE TELEPHONES



Closed View

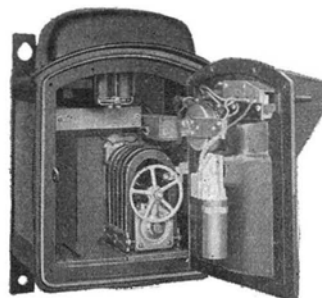

Open View

No. 1536E Mine Telephone Set
(U. S. Bureau of Mines Permissible Type)

This type is for use in mines where explosive gas is present. In the words of the United States Bureau of Mines the Western Electric Mine Telephone, Type No. 1536E "is permissible for use in mines or other locations where methane or other explosive gases or coal dust are or are likely to be present in dangerous proportions."

This telephone set is enclosed in a cast iron housing $8\frac{7}{16}'' \times 11\frac{1}{4}'' \times 17\frac{5}{32}''$ having a sloping roof and a hood extending out from the top of the door. These two features protect the working parts of the set from damage by falling debris and facilitate the shedding of water. This construction permits mounting the transmitter, receiver and generator-handle entirely exposed on the door but under the protection of the hood. The set is therefore under all conditions immediately recognizable as a telephone.

Safeguards Against Sparking

The design of this set safeguards against explosions which might result from the sparking of the switchhook and generator shunt spring contacts. Safeguards against explosions due to sparking caused by poor or loose connections also have been incorporated and every precaution has been used to guard against mechanical injuries to coils and other parts which might later develop into sparking points.

The possibility of loose connections is reduced to a minimum by the use of closed eye cord tips and screw-and-nut binding posts for all connections.

A special cord is used to connect the receiver to the set. This cord will withstand unusual twisting and pulling without injury to the insulation. This protection is provided to eliminate any possibility of bare wires coming in contact with the telephone housing when the ringing current is on the line and thus cause sparking. Special clamps are provided on both ends of the cord to prevent undue strain on the conductor wire.

Protection Against Dampness

Complete protection is given to all parts in the set against the usual moist or damp conditions prevailing in mines. Line wires may be brought in at either the top or bottom of the set. When the wires are brought in at the top, an 180-degree angle fixture is used to keep out the moisture. Holes in the bottom of the housing provide for the drainage of any moisture which might accumulate.

The internal mechanism, batteries, line connections, etc., are carefully housed. Access cannot be had without opening the lock and removing the cap screws around the sides of the door. Separate units, such as the switchhook, generator and ringer are individually removable for repair.

A dry battery meeting requirements of the American Standards Association for telephone batteries is required.

Impregnated cartons give the batteries further protection. Impregnated cartons need not be replaced when new batteries are required.

Repairs and Renewals

Since the Western Electric Mine Telephone Set has been approved by the Bureau of Mines, parts used for repair or renewal must be identical with those furnished. Renewals or repairs should be made only by an experienced and a competent person. A person who does not understand the many protective features of the set might, by tampering, endanger the lives of many persons.

TELEPHONES—MAGNETO

Mine Telephones—Continued

Parts List

The parts which have been approved for replacement are:

- | | |
|------------------------------|-----------------------------------|
| P-201339 Impregnated Cartons | 04606 Eagle Padlock with two Keys |
| 51-A Generator | 558W Receiver |
| 63-B Ringer | 312W Transmitter |
| 149-A Switchhook | R2AD Cord |

Dry Batteries. A dry battery meeting requirements of the American Standards Association for telephone batteries should be used.

PROTECTORS

The telephones installed above ground should be equipped with protectors consisting of open space cut outs to prevent damage to the telephone by lightning. In case there is a chance of contact between the telephone line and a power circuit protectors consisting of open space cut outs and fuses should be used.

TYPICAL WESTERN ELECTRIC MINE TELEPHONE SYSTEMS

In the following illustration are shown two types of mine telephone installations, one with and one without a switchboard.

The No. 1336 Type Telephone Set is used in this illustration but as stated previously should be replaced by the No. 1536E Type where there is danger from explosive gases.

Typical Western Electric Mine Telephone Systems

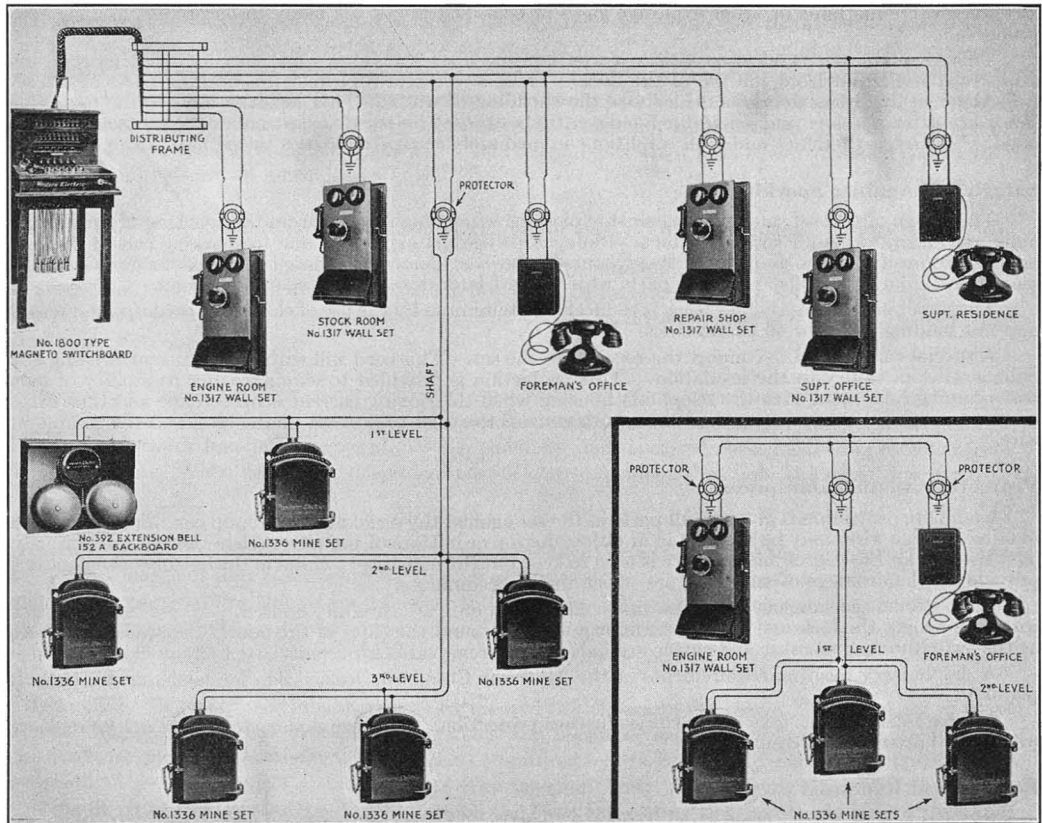

Typical Diagram Showing Method of Connecting Telephones to a Switchboard

Typical Party Line Mine Telephone System

TELEPHONES—MAGNETO
Mine Telephones—Continued

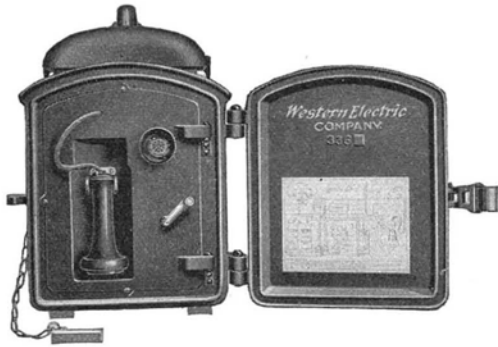

No. 1336 Mine Telephone (Outer Door Open)



No. 1336 Mine Telephone (Outer and Inner Doors Open)

The No. 1336A Telephone is not equipped with a ringer as it is intended for use where an extension bell is preferred to the regular telephone ringer, also for service where all the calls will be outgoing.

The Nos. 1336E and K differ from the No. 1336A in that they are equipped with a ringer and an iron hood for protecting the gongs.

The No. 1336J differs from the No. 1336E only in that a condenser is provided to permit the ringers of this telephone as well as others on the same line, being rung even though its receiver may have been left off the switchhook.

Code No.	Transmitter	Receiver	Receiver Cord	Condenser	Ringer		Generator	Signalling Service	For Line Load
					Code No.	Resistance			
1336A	312	144	384	None	None	2500	48C	{ Code Ringing	{ Heavily Loaded
1336E				None	45BG				
1336J				10½ in.	45BG	2500			
1336K				149A	{ (Spl.) 45BG	1600			

In addition to the apparatus listed above the No. 1336 Type Telephones are equipped with a No. 143J Switchhook and a No. 31 Induction Coil.

Special No. 1336 Type Telephones equipped with a heavy brass padlock with two keys are obtainable. The padlock is attached to the chain in place of the latch pin. Orders for these telephones must state that padlocks are desired.

TELEPHONES—MAGNETO
Mine Telephones—Continued

REPLACEMENT PARTS FOR NOS. 1336A, E, J, AND K MINE TELEPHONE SETS

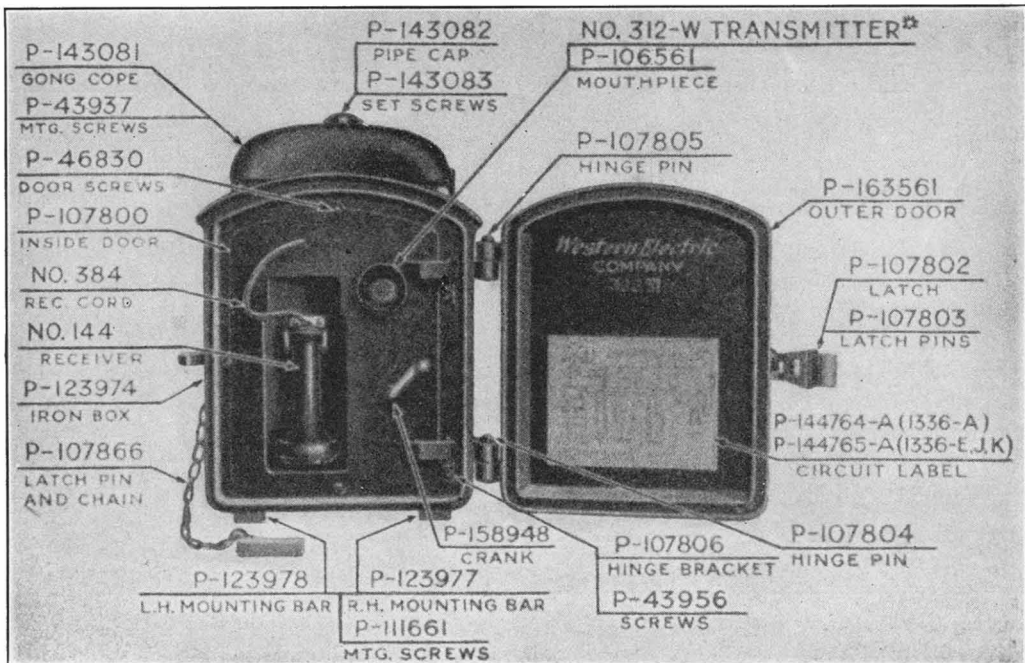
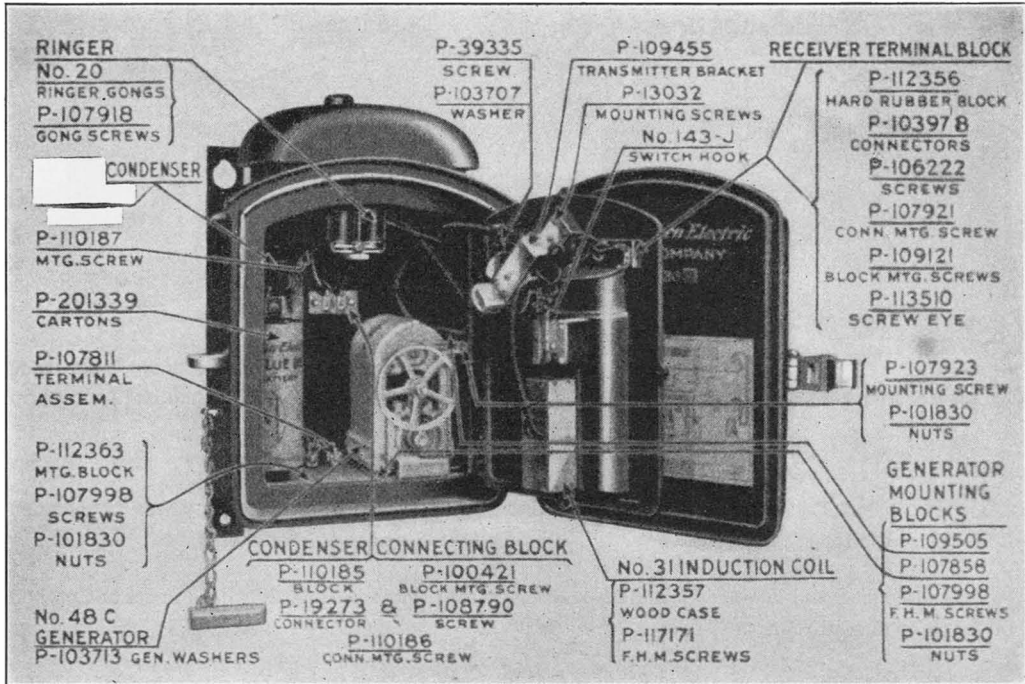

TELEPHONES

Street Railway Magneto and Central Battery Types



No. 1278G Telephone

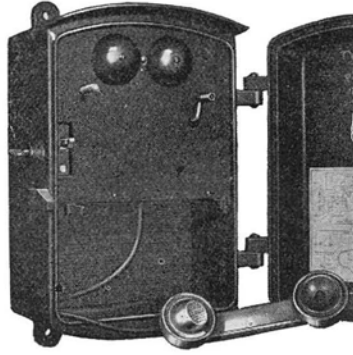

Open View

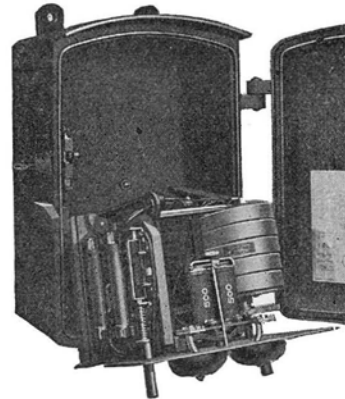

Apparatus Shelf partially removed

NO. 1278 TYPE

No. 1278 Type Telephones employ weatherproof iron boxes and are provided with "insulated" circuits. They are intended principally for exterior use by street railway companies operating telephone lines on which there is a chance of crosses with low voltage power circuits.

This type telephone is arranged so that its circuit is cut off from the line except when its door is opened. When the telephone is in use a repeating coil is interposed between the line and the telephone circuit proper, so as to protect the user, as far as possible, from the chance of injury should the line become crossed with a low voltage circuit.

When the door is opened, a line switch is released which connects one winding of the repeating coil across the line and connects two fuses and two open space cut-outs into this circuit. The telephone circuit proper is connected to the second winding of the repeating coil and, therefore, has no direct contact with the line circuit. The fact that a repeating coil is interposed between the line circuit and the telephone circuit, of course, reduces the efficiency of the telephone to some extent and, therefore, the use of these telephones is not recommended on heavily loaded lines, except where the protective feature is essential. See No. 1336 Type Telephones.

In case a car is held up awaiting orders from the dispatcher the door of the telephone is left open so as to permit of the telephone being signalled. (It is impossible for the telephone to be signalled when its door is closed.) As the talking circuit is only closed when the push button in the hand set is depressed, the battery in the telephone is not wasted under the above condition.

The apparatus of this telephone is mounted on an iron shelf, which may be removed as a unit from the telephone for inspection. The connection between the apparatus on the shelf and the line and ground terminals is made through the medium of clips which register with contacts mounted on a terminal block secured to the back of the case.

The case and door are of cast iron and have a galvanized finish in addition to which they are given two coats of green paint. Both the top and bottom ends of the case are tapped for receiving 1/2 inch conduit.

The telephones are equipped with a lock which is arranged so that the key cannot be removed until the door of the telephone is closed.

Code No.	Hand Set	Ringer		Generator	Ind. Coil	Repeating Coil	Lock	Class of Signal Service	For Line Load
		Code No.	Resistance (Ohms)						
For Magneto Service									
1278G	1001H	51AG	1000	*48C	13	25E	5B	†Code	Medium

In addition to the apparatus listed above this telephone is equipped with: A special door switch and a special protector.

- 2 D. & W. No. 5001 Type C Fuses—500 volt 1 ampere.
- 2 No. 1 Protector Blocks.
- 2 No. 2 Protector Blocks.
- 2 No. 3 Protector Micas.

Dry cells are not furnished and must, therefore, be ordered as a separate item.

* Generators have special mounting brackets.

† The ringer is disconnected from the line when the door of the telephone is closed.

TELEPHONE SET FOR ELEVATOR CARS

This consists of a 525A Subscriber's Set, a 323 Transmitter and a 559 Receiver. The Subscriber's Set contains the following apparatus:

- 1—150A Switchhook
- 1—149A Condenser
- 2—29C Gongs
- 1—46B Induction Coil
- 2—T1A Cords, 3" long
- 1—68A Ringer

TELEPHONES—CENTRAL BATTERY

Central Battery Telephone Systems

SINGLE PARTY, 2 PARTY SELECTIVE OR 4 PARTY SEMI-SELECTIVE SYSTEMS EMPLOYING ALTERNATING CURRENT

On an individual line, the ringer is bridged across the two line wires. (In the case of central battery systems, condensers are connected in series with the ringers, except in the case of ringers operated on pulsating or superimposed ringing current, as described below). On a two-party selective line, one ringer is connected from each side of the line to ground, and on a four-party semi-selective line, two ringers are connected from each side of the line to ground, the switchboard at the central office being so arranged that by means of a key, current can be sent out over either side of the line, through the ringers connected to that side of the line, to ground. In other words, one terminal of the central office generator is connected to one of the line wires and the other terminal to ground. It is the usual practice to temporarily ground the opposite side of the line from that to which the ringing current is connected. This is to prevent cross ringing when a receiver is lifted from the hook. (This class of ringing is often referred to as "divided circuit ringing.")

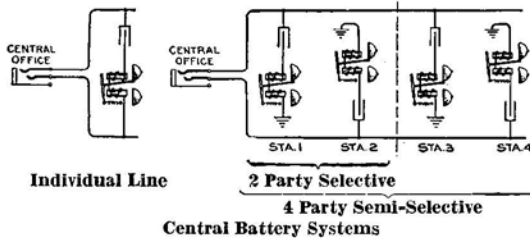

temporarily ground the opposite side of the line from that to which the ringing current is connected. This is to prevent cross ringing when a receiver is lifted from the hook. (This class of ringing is often referred to as "divided circuit ringing.")

FOUR PARTY SELECTIVE—EMPLOYING PULSATING OR SUPERIMPOSED CURRENT

Condensers cannot be connected in series with ringers operated on pulsating current, because if used, pulsating current would have the same effect as alternating current and the selective feature could therefore not be obtained. In view of this and the fact that a ringer cannot be permanently bridged across a central battery line or from the line to ground unless a condenser is connected in series with it, the following arrangement is employed where pulsating or superimposed current is used for four-party selective signalling on central battery lines. Each of the four telephones is equipped with a high impedance relay, which is permanently bridged across the two line wires in series with a condenser. When ringing current is sent out over one side of the line to ground (and the opposite side of the line temporarily grounded), the armature of each of the relays pulls up, thereby closing a contact. The ringers are connected to ground through these contacts; that is, the ringer of each telephone is connected to ground when the relay armature is pulled up and is cut out of the circuit as soon as the ringing current ceases. The ringers are connected as in the four-party selective magneto system, described above; that is, two ringers are connected from each side of the line to ground, those connected to each side of the line being connected so that one will operate on negative pulsating current and the other on positive pulsating current.

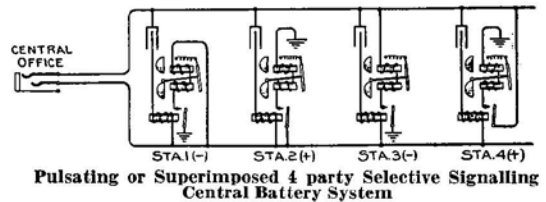

HARMONIC—4 PARTY SELECTIVE

The telephones used with this system are equipped with special ringers which are so made that they will ring only when alternating current of a given frequency is sent out over the line. The frequencies employed are $16\frac{2}{3}$, $33\frac{1}{3}$, 50 and $66\frac{2}{3}$ cycles, per second.

On a four-party selective line, each of the four telephones is equipped with a ringer which will operate on current of a different frequency than the others. These are bridged across the two-line wires.

A condenser is connected in series with harmonic ringers in all cases.

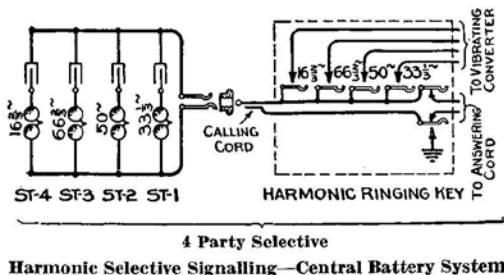

TELEPHONES—CENTRAL BATTERY

GENERAL

Telephones representing the highest and most modern development in central battery telephone design are found in the No. 1533 Type and in the No. 6065 Type listed on the following pages.

In addition to the superior features represented by the individual pieces of apparatus and circuits, these telephones embody a number of features that are particularly worthy of note, namely:

Ringer and gongs are enclosed within the case thereby preventing tampering, reducing maintenance and greatly improving the appearance.

The case of the No. 1533 Type is made of heavy sheet steel, copper plated and finished with two coats of extremely durable black enamel (baked on) especially developed for this particular purpose.

The case is constructed so that every part of the interior is easily accessible when the cover is opened.

The base is flanged thereby giving greater rigidity and preventing base from cutting into plastered surfaces.

Unit type of construction and universal terminal block employed. This permits of the telephone being readily converted from one class of service to another. This also permits of a desk set box being converted into a wall telephone or vice versa by a substitution of covers.



No. 1533 Type Telephone on a No. 148A Backboard with a No. 146A Backboard (writing shelf)



No. 1533A Telephone

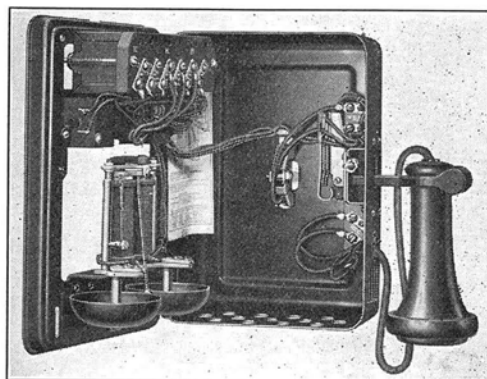

Inside View of No. 1533A Telephone

No. 1533 Type Telephone

The No. 1533A Telephone is arranged for single-party, two party selective or four-party semi-selective ringing service from the central office.

The No. 1533K telephone is of the series type as described under "Transmission Circuits" elsewhere, otherwise used for same service as described above for the No. 1533A.

The No. 1533Y Telephone is arranged for central battery ringing service as outlined for the No. 1533A but it is equipped for local battery talking.

The No. 1533AR Telephone is equipped with pulsating current type ringers for use in four-party selective signalling from the central office.

The Nos. 1533E, F, G, and H Telephones are arranged for four-party selective or eight-party semi-selective ringing service from the central office.

No. 1533 Wall Type Telephones

Code No.	Transmitter	Receiver	Ringer No.	Resistance (ohms)	Condenser	Induction Coil	For Ringing Current
1533A	323	144	68AG	1500	149A	46B	A.C.
1533K	323	171	68AG	1500	149A	—	A.C.
1533Y	323	144	68AG	1500	149A	13	A.C.
*1533AR	323	144	72AG	{ 1000 and 3000 }	149A	46B	P.C.
1533E	323	144	41SG	33 1/3 cycles	149A	46B	Harmonic
1533F			41TG	50 cycles			
1533G			41UG	66 2/3 cycles			
1533H			41RG	16 2/3 cycles			

* Equipped with No. 85N Relay.

TELEPHONES—CENTRAL BATTERY

No. 1533 Type Telephones—Continued

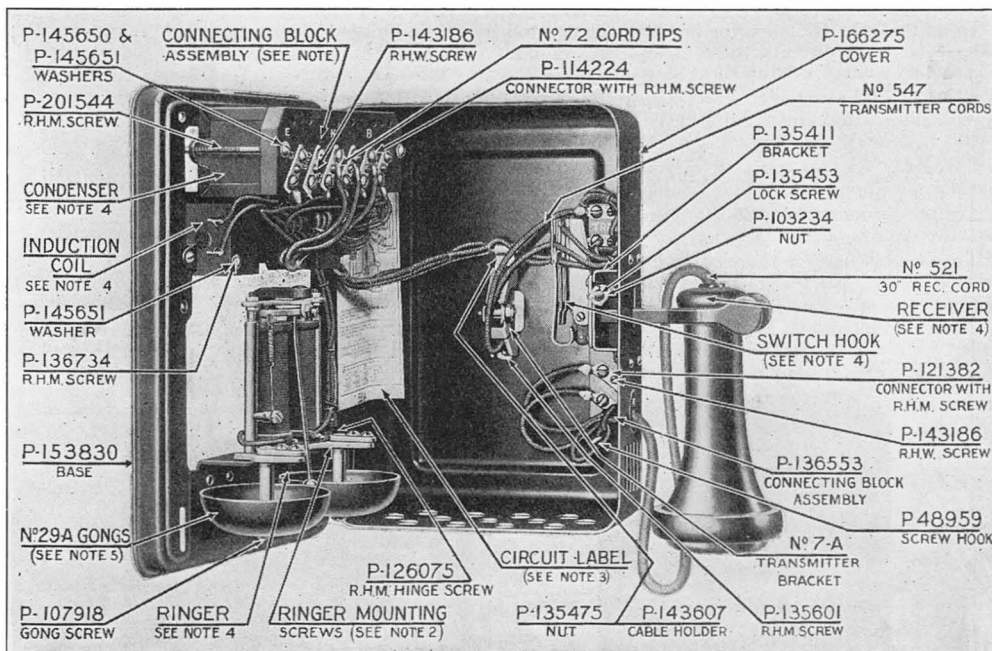

Replacement Parts

Note 1. Connecting block assembly for:

Code No.	Part No.
1533A and E	P-158349
1533K	P-158351
1533Y	P-158354
1533AR	P-158355

Note 2. Ringer mounting screws for:

Code No.	Part No.
1533A, K, Y and AR	P-153832
1533E, F, G and H	P-145368

Note 3. Circuit label for:

Code No.	Part No.
1533A	P-144936
1533E, F, G and H	P-144606
1533K	P-144938
1533Y	P-144942
1533AR	P-244024

Note 4. These parts are shown with the code number listings.

Note 5. The No. 29A Gong is regularly furnished. If different tone gongs are required, the Nos. 31A, 32A or 33A Gongs may be used. (See description of Gongs.)

The replacement parts for ringers, etc., are shown elsewhere under their respective headings.

TELEPHONES—CENTRAL BATTERY

NO. 1553 TYPE



No. 1553A Type Telephone

The No. 1553 Type Telephone Set is a common battery sidetone wall set with enclosed gongs. It has a metal case finished in black. This set is primarily intended for dial service, but is also intended for manual service in districts where a change to dial service is contemplated.

For dial service it requires a No. 4H Type dial which is not furnished unless specified. Also when specified in the order will be furnished equipped with a No. 61D filter to suppress dialing induction into radio receiving sets.

For manual service it requires a No. 50B apparatus blank which is not furnished unless specified. The leads of the set will be connected for manual service unless sets are ordered equipped with dials.

The No. 1553A Telephone is arranged for single party, two-party selective or four-party semi-selective ringing service from central office.

The No. 1553Y is arranged for central battery ringing service as above, and is equipped for local battery talking.

The Nos. 1553E, F, G and H Telephones are arranged for four-party selective or eight-party semi-selective ringing service from central office.

Code No.	Dial	Ringer		Resistance	Ind. Coll	Condenser	Ringing Current A. C.
		Code No.					
1553A	} As specified in order	68AG		1400	46B	149A	} Harmonic
1553E		41SG	{ 33 1/3 cycles	46B	149A	
1553F		41TG	{ 50 cycles	46B	149A	
1553G		41UG	{ 66 2/3 cycles	46B	149A	
1553H		41RG	{ 16 2/3 cycles	46B	149A	
1553Y		68AG		1400	13	149A	

The following apparatus is common to the wall type telephone listed above:

- One—No. 140S Switch Hook
- One—No. 323 Transmitter
- One—No. 144 Receiver

- One—No. 521 Receiver Cord—18 inches long
- Two—No. T1A Transmitter Cords—8 inches long

INSTRUCTIONS FOR ORDERING TELEPHONES

In addition to specifying the code number of the telephone desired, information must be given as to the dial that is to be furnished as the dial is not included as a part of these telephones (nor is it included in their price). For example, orders should read as follows:

- 10—No. 1553A Telephones
- 10—No. 4HA-3 Dials

In case the machine switching feature is not desired, the order should read as follows:

- 10—No. 1553A Telephones
- 10—No. 50B Apparatus Blanks

TELEPHONES—CENTRAL BATTERY**Anti-Sidetone—No. 6065 Type**

**No. 202 Type Hand Telephone Set and
No. 634 Type Subscriber Set**

The No. 6065 Type Telephones are of the anti-sidetone type and consist of a No. 202 Type Hand Telephone Set and a No. 634 Type Subscriber Set.

Combinations of apparatus differing from those covered by the series of code numbers listed below may be obtained by ordering a hand telephone set and subscriber set as separate items.

The Nos. 6065E, F, G and H Telephones are arranged for four-party selective or eight-party semi-selective ringing service from the central office.

The No. 6065AR Telephone is equipped with pulsating current type ringers for use in four-party selective signaling from the central office.

Code No.	Hand Tel. Set	Sub. Set	Subscriber Set Contains				For Ringing Current
			Ringer No.	Resistance	Condenser	Ind. Coil	
6065E	202A-3	634E	41SG	33 $\frac{1}{3}$ cycles	194A	146B	} Harmonic
6065F	202A-3	634F	41TG	50 cycles	194A	146B	
6065G	202A-3	634G	41UG	66 $\frac{2}{3}$ cycles	194A	146B	
6065H	202A-3	634H	41RG	16 $\frac{2}{3}$ cycles	194A	146B	
6065AR	202A-3	*634AR	72AG	1000 & 3000	194B	146B	} P.C.

* Equipped with No. 85N Relay.

The No. 6065 Type Telephones will be furnished with the No. 202A-3 Hand Telephone Set as listed above, unless otherwise specified in the order. When so specified the 202B-3, 202C-3 or 202D-3 will be furnished. For information regarding these hand telephone sets, see section entitled "Hand Telephone Sets."

For further information on Anti-sidetone Telephone Sets for classes of service other than listed, consult our nearest distributor.

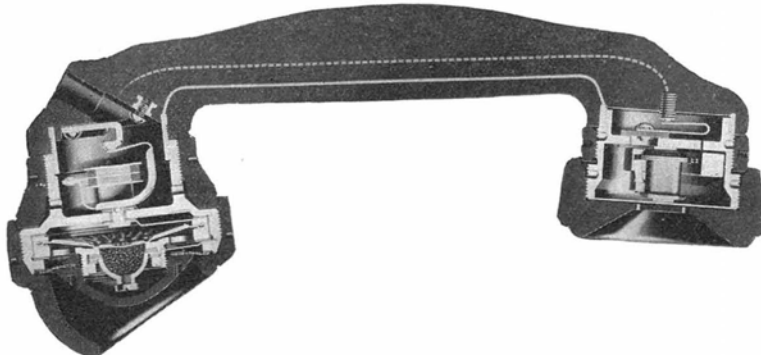

Cross Sectional view of EID Type Handset which forms part of 300 Type Telephone Set

TELEPHONES—CENTRAL BATTERY

Anti-Sidetone Type—Continued

NO. 300 TYPE TELEPHONE SET FOR OUTDOOR USE

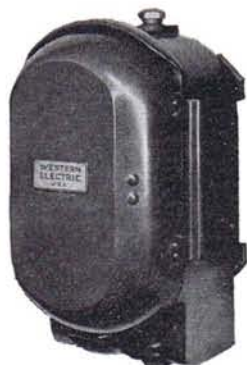

Closed View

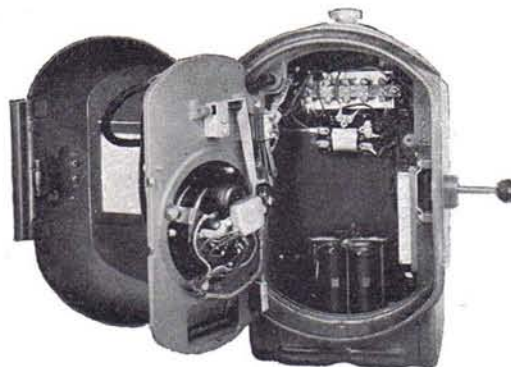

Inner Door Open

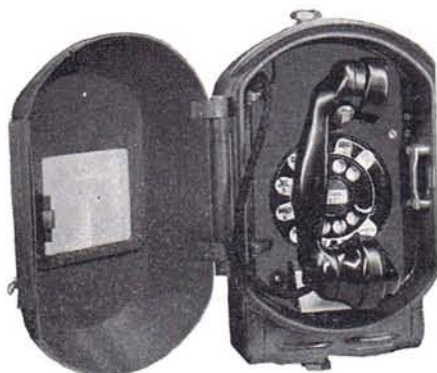

Outer Door Open

The No. 300 Type Telephone Set is for outdoor use in anti-sidetone equipment in either manual or dial service. It consists of a gray finished metal mounting in which the induction coil, ringer and condensers are assembled. A moisture-proofed handset is hung on a switch hook which is assembled to the inner door. The inner door also provides a method of mounting the dial or apparatus blank. The outer door is fastened by means of a lock and has an instruction card holder welded to its inside surface.

Overall dimensions are approximately 1' 1" high x 9" wide x 6 1/4" deep.

The No. 300AW Telephone Set is arranged for manual service and the Nos. 300BW, CW and DW Telephone Sets

are arranged for dial service.

A No. 29A Bracket is required for use in mounting each of these Telephone Sets on buildings, fences, poles, etc., and must be ordered separately.

When it is desired to eliminate interference to radio reception where a dial is used a No. 61L filter is required. This filter is furnished and assembled only when specified in the order.

Arranged to mount a No. 85N relay, when required for auxiliary signaling, by means of a bracket both of which must be ordered separately.

Telephone Set	Dial	Number Plate	Dial Adapters	Apparatus Blanks
300AW	—	—	—	80A
300BW	4HA-3	147A	56A & 58A	—
300CW	4HB-3	147B	56A & 58A	—
300DW	4HE-3	147E	56A & 58A	—

NOTE: In addition to the apparatus listed above each set contains the following: 2 No. 29C Gongs, 1 No. 147A Condenser, 1 No. 155B Induction Coil, 1 No. 68L Ringer, 1 No. 149D Condenser and 1 No. E1D Handset.

TERMINAL STRIPS

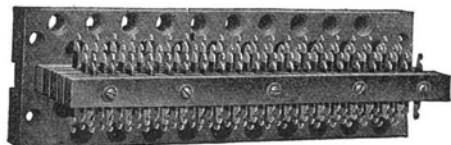

No. 35



No. 53

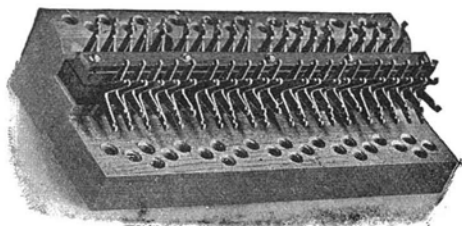

No. 65

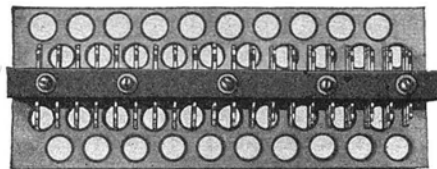

Nos. 100A and 101A

The Nos. 53 and 69 Terminal Strips are composed of a 3 ply laminated maple wooden base having holes into which the terminal punchings are driven.

All other models have a solid maple base upon which are assembled hard rubber insulating strips which hold the terminal punchings in place. The base is drilled to act as a fanning strip for wires and the holes are chamfered to prevent injury of the insulation. These Terminal Strips are furnished unnumbered unless otherwise specified. The Nos. 100 and 101 Types are provided with a clamping strip which is wide enough to permit of four characters being used for each stack of terminals. The Nos. 100 and 101 Types are arranged to mount on a 1/2 inch by 1/2 inch bar by means of two 1 1/4 inch No. 10-32 round head iron machine screws, which are furnished with the Terminal Strips.

The Nos. 65 and 93 Types are for use with main distributing frames.

The No. 53 Type is for use with No. 9 Switchboards.

The Nos. 35 to 70 Types are for use with intermediate distributing frames.

The Nos. 85, 88, 91, 92, 100, 101, 184 and 185 Types are for general switchboard purposes.

Code No.	Number of Terminals per Row	Number of Rows of Terminals	Length of Strips in Ins.	Width, Ins.	Height Overall, Ins.
35	20	3	7 31/32	2 17/32	2 1/2
36	20	4	7 31/32	2 17/32	2 29/32
37	20	5	7 31/32	2 17/32	3 1/4
38	20	3	6 15/32	2 19/32	2 1/2
39	20	4	6 15/32	2 19/32	2 27/32
40	20	5	6 15/32	2 19/32	3 1/4
41	20	6	6 15/32	2 19/32	3 5/8
51	20	6	7 31/32	2 17/32	3 5/8
53	20	2	10	3 1/32	2
65	*40	1	7 31/32	3 3/8	2 1/8
83	20	2	13 1/2	1	1 7/8
85	20	6	6 15/32	2 19/32	4 1/64
83	20	4	6 15/32	2 19/32	3 1/4
91	20	5	7 31/32	3 3/8	3 23/64
92	20	3	7 31/32	3 3/8	2 39/64
93	20	4	7 31/32	3 3/8	2 63/64
99	50	6	14 7/16	2 19/32	3 1/2
100A	20	3	6 1/16	2 15/16	2 29/32
100B	20	4	6 1/16	2 15/16	3 3/32
100C	20	5	6 1/16	2 15/16	3 21/32
100D	20	6	6 1/16	2 15/16	4 1/32
101A	20	3	7 9/16	2 15/16	2 29/32
101B	20	4	7 9/16	2 15/16	3 3/32
137A	50	6	14 7/16	2 19/32	3 15/16
148A	22	7	8	2 19/32	4 23/64
163A	50	8	14 7/16	2 19/32	4 1/8
184B	20	7	7 31/32	2 17/32	3 23/32
185A	30	6	11	2 19/16	4

* Three way.

TESTING APPARATUS
Portable Test Sets

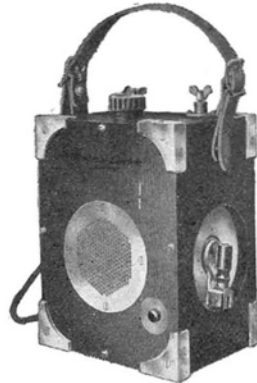

No. 1017 Type Test Set

NO. 1017C TEST SET consists of a wooden box telephone set equipped with a regular battery talking circuit consisting of a standard transmitter, induction coil, receiver and a special three cell dry battery unit. It can be used either on magneto or central battery lines. Will ring through 5,000 ohms. Contains:

Code No.	Description	
1017C	1 No. 2D Buzzer	1 No. 703 Eveready Battery
	1 No. 29F Generator	(must be ordered separately)
	1 No. 572 Cord	1 Special Switch
	1 No. 13 Induction Coil	3 No. 3C Binding Posts
	1 No. 515 Receiver	
	1 No. 266 Transmitter	

THE NO. 1017E TEST SET is similar to the No. 1017C except it is equipped for use on either composited or straight telephone lines. Contains:

1017E	*1 No. 29F Generator	1 No. 714 Eveready Battery (must be ordered separately)
	1 No. 2E Buzzer	
	1 No. 515 Receiver	1 No. 572 Cord, 2 ft.
	1 No. 13 Induction Coil	1 No. 6000A Interrupter
	1 No. 266 Transmitter	

* This generator will operate a No. 56A Drop through 11,500 ohms resistance.

The above sets have a birch mahogany finish. Size of case, length 6³/₃₂" , width 4²⁷/₃₂" and height 7²⁷/₃₂". Weight 7 lbs.

D86418 Similar to a No. 1017E Test Set except that it includes an exploring coil, special switching device, and a modified circuit for controlling the test tone for the exploring coil. This set is intended to fulfill the standard uses for the No. 1017 Type Sets and in addition includes a fault direction locating feature for use in testing open wire lines. The No. 515 Receiver and No. 266 Transmitter are required for operation but must be ordered separately.

Nos. 90510 to 90530

Consist of a generator and ringer, in series for testing through various line resistances.

The case of the set is finished in birch and is designed to withstand rough handling. A leather strap handle is provided.

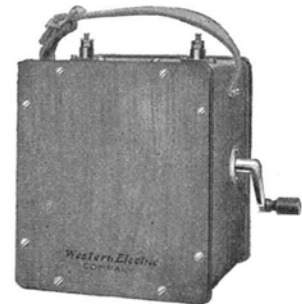

No. 90530 Test Set

List No.	Generator	Ringer		Gen. Operates Ringer Through	Size of Case in Inches
		Type	Ohms		
90530	22K	19B	2500	10,000 ohms	5 ³ / ₄ x 6 ⁵ / ₈ x 5 ¹ / ₄
90510	22K	19H	500	35,000 ohms	
90511	22N	19A	1000	50,000 ohms	
90512	22N	19B	2500	100,000 ohms	

PORTABLE TEST SETS—Continued

No. 43A Test Set



No. 1020C Test Set

Code No.**Description**

43A

Splicer's Portable Test Set. Intended for use in connection with the installation and maintenance of cable in manual or dial telephone areas. Consists of a buzzer circuit which provides tone for identifying wires for balance testing and for running down resistance faults on short non-loaded cable by the exploring coil method; together with auxiliary circuits which provide for a battery for detecting defective pairs by receiver battery tests or for energizing the transmitter of a talking set and a ringer buzzer by means of which the splicer may be called from a central office when communication with him is desired. Woodwork birch, finish olive-green. Contains:

10 Binding Posts	1 No. 15 Lungen Buzzer, Size No. 2, wound to 40 ohms
1 No. 21F Condenser	2 No. 771 Eveready Batteries required (must be ordered separately)
1 No. 21R Condenser	1 No. 13 Induction Coil
1 No. 2D Buzzer	
2 SPST Snap Switches	
2 No. 1AG Resistances	

45A

This is a portable set designed to facilitate the usual testing done by splicers in connection with the installation and maintenance of cables. It provides a space for a battery which by means of a dial switch in the test set furnishes a voltage of either $4\frac{1}{2}$, 9, $31\frac{1}{2}$ or 54 volts for supplying direct current for Wheatstone bridge measurements. It includes a buzzer circuit which provides tone for identifying wires, for balance testing and for locating low resistance faults on a short non-loaded cable by the exploring coil method.

The woodwork is birch, finished in olive green.

1020C

Designed for use by cable repairmen as a portable test set for locating shorts, grounds, crosses, split pairs and wet spots in cables. The case has a birch mahogany finish and weighs $12\frac{1}{2}$ lbs. without batteries. Size $12\frac{1}{16}$ " wide, $6\frac{7}{16}$ " deep and $10\frac{7}{16}$ " high. Consists of the Nos. 20C and 1019C Test Sets, the latter being contained in the case of the former:

THE NO. 1019C TEST SET consists of the No. 19C Test Set equipped with one No. 747 Cord, one No. 186 Plug and one No. 528 Receiver.

THE NO. 19C TEST SET consists of an exploring coil, a condenser and three jacks enclosed in a nickel silver case.

THE NO. 20C TEST SET consists of the following apparatus:

3 No. 540 Cords	1 Interrupter
1 No. 18AC Resistance	1 2-Point Switch
1 No. 21K Condenser	4 Dry Cells (must be ordered separately)
1 Vibrator	

1120C

This Test Set is the same as the No. 1020C Test Set except that it contains a No. 1119C Test Set instead of a No. 1019C.

THE NO. 1119C TEST SET consists of a No. 19C Test Set equipped with one No. 584 Cord, one No. 186 Plug, one No. 1A Headband and two No. 502 Receivers.

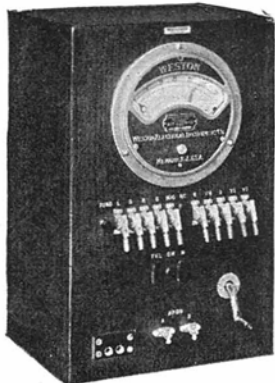
TEST SETS**No. 1407C Testing Cabinet.****No. 1407C Test Cabinet**

This Testing cabinet provides adequate, efficient, and reliable testing equipment, which is adaptable to either magneto or central battery systems. All classes of trouble, such as grounds, short circuits, crosses, open circuits, high resistance, can be tested for and the location calculated from the direct reading voltmeter with no complicated mathematical calculations involved.

On exchanges where the installation of a regular wire chief's desk is not warranted, the installation of the No. 1407C Testing Cabinet is the ideal testing equipment. It can be installed at either side of the switchboard or at the end of the main frame, or any convenient place in the central office. The operation is simple and the operator can be trained to assist in making tests which would aid materially in clearing up trouble after a storm.

The consistent application of the simple tests featured in this cabinet will eliminate the guesswork from small exchange maintenance and tend to raise the service on the exchange to a higher level by clearing troubles with the utmost dispatch. The cabinet is compact measuring overall, height 18 ins., width 12 ins., depth 9½ ins. Constructed of birch with a durable mahogany finish.

EQUIPMENT

It is equipped with the standard "Weston Voltmeter" which is well known for its accuracy and reliability. If the voltmeter is not accurate and dependable, all results of the testing will be unreliable.

This cabinet is stocked in accordance with Lists Nos. 1 and 1C, but can be furnished with alternative features as specified in the order. These alternative features have been grouped as follows:

Lists No. 1 and No. 1C

List No. 1 consists of one No. 1407C Testing Cabinet equipped for one local battery (magneto) system.

List No. 1C consists of one Weston Model 24 Voltmeter (0-30 volts) with 10,000 ohm resistance, calibrated and adjusted for vertical mounting.

A copy of specification covering "Method of Operation" is included in this list.

List No. 1A

List No. 1A covers the equipment required in addition to Lists Nos. 1 and 1C, for a 24 volt common battery testing cabinet.

List No. 1B

List No. 1B covers the equipment required in addition to Lists Nos. 1 and 1C, for a 38 volt common battery testing cabinet.

List No. 2

Testing battery equipment. This list consists of:

- 3—No. 540 Cords
- 1—No. 766T Eveready Battery
- 3—No. 771 Eveready Batteries

List No. 3

Distributing frame testing equipment. Consists of:

- 4—No. 9 Cord Fasteners
- 1—No. 716 Cord (10 ft.) equipped with
- 1—No. 206 Plug

List No. 4

Covers the Two-conductor Switchboard Test Cords. This list consists of:

- 1—No. S2A Cord (8 ft. white) equipped with
- 1—No. 47B Plug
- 1—No. S2A Cord (8 ft. green) equipped with
- 1—No. 47B Plug

List No. 5

Covers the Three-conductor Switchboard Test Cords, for Switchboards using No. 92 or similar type Jacks. Consists of:

- 1—No. S3A Cord (8 ft. white) equipped with
- 1—No. 109 Plug
- 1—No. S3A Cord (8 ft. green) equipped with
- 1—No. 109 Plug

List No. 6

Covers the Three-conductor Switchboard Test Cords, for Switchboards using No. 49 or similar type Jacks. Consists of:

- 1—No. S3B Cord (8 ft. white) equipped with
- 1—No. 110 Plug
- 1—No. S3B Cord (8 ft. green) equipped with
- 1—No. 110 Plug

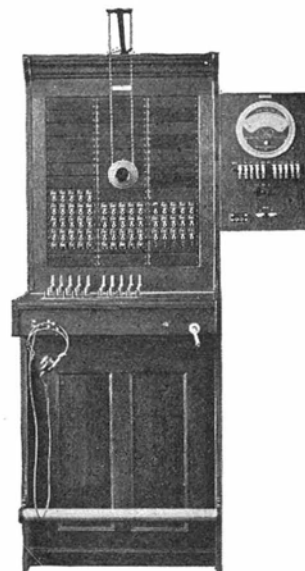
**Showing Cabinet Mounted on Switchboard**

TEST SETS

No. 1407C Testing Cabinet—Continued

List No. 7

Sleeve Make-busy Key for testing common battery lines having cut-off relays. This list consists of one No. 378A Key equipped with a No. 6A Key Lever and a 12B Number Plate.

Lists No. 8 and No. 8B

List No. 8 covers the equipment for the Call Circuit and the Telephone Line to a magneto switchboard. Consists of 1 No. 390A Key; 1 No. 381A Key with 6A Key Lever; 2 12B Number Plates.

List No. 8B consists of a No. 127A Subscribers Set which is used in conjunction with the equipment covered by List No. 8.

List No. 8A

This list covers the equipment required in addition to List No. 8 when the Call Circuit and Telephone Line connects to a common battery switchboard. Consists of 1 No. 628A Mounting Plate equipped with 1 No. 47F Retardation Coil.

List No. 9

This list covers the Transmitter Battery for local battery (magneto) offices. Consists of two No. 540 Cords and three No. 6 Dry Cells.

List No. 10

This list covers the Ringing Keys for four-party selective, harmonic, or pulsating ringing. Consists of four No. 378A Keys equipped with No. 6A Key Levers and 12B Number Plates.

List No. 11

Consists of a special 48B Hand Generator for four-party pulsating magneto ringing.

List No. 12

Consists of a 48J Hand Generator for two-party selective, four-party semi-selective, and bridged magneto ringing.



No. 1407C Testing Cabinet Connected to Main Distributing Frame

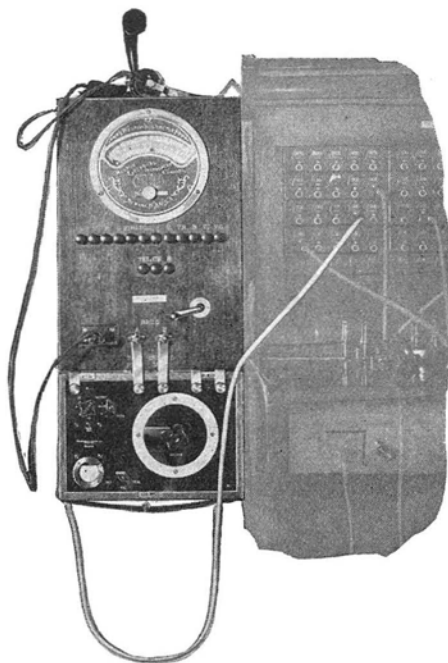

No. 1407 Testing Cabinet with No. 1407 Bridge Unit Attached to the Side of a Switchboard

Auxiliary Equipment for Use with No. 1407C Testing Cabinet

NO. 1407A BRIDGE UNIT

For a more accurate means of making resistance measurements than is possible with a voltmeter, the No. 1407A Bridge Unit was developed. It consists of a Wheatstone Bridge outfit and is so designed that it will line up and attach by means of No. 1407B Bracket Unit to the bottom of a No. 1407C Testing Cabinet.

With this equipment Murray and Varley loop tests as well as straight resistance measurements can be quickly made in addition to the regular voltmeter testing possible with the No. 1407C Testing Cabinet.

Unknown resistances can be read directly from the scale without referring to tables or other data, and such readings are accurate up to one-half of one per cent.

This bridge unit is easily detached from the testing cabinet by loosening the binding posts holding the bracket unit straps and moving the bridge about an inch to the right. When removed it can be used as a portable bridge. A cover and carrying strap are provided.

TOOLS

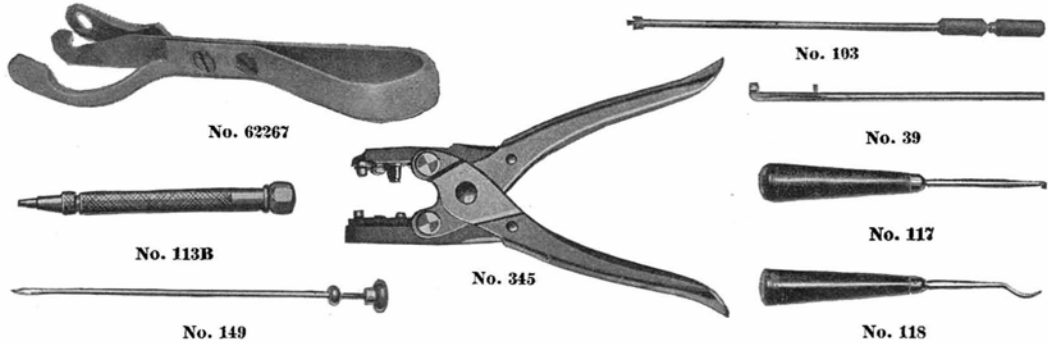

CABLE AND CABLE TERMINAL TOOLS

Code No.	Use	Approximate Dimensions Inches, Overall
216B	Combination double end screwdriver and double end socket wrench (taking hexagonal nuts, $\frac{3}{8}$ in. and $\frac{7}{16}$ in. across flats) for use in placing fuses in cable terminals and connecting wires to fuses and binding posts. The socket wrenches may be extended beyond the screwdriver ends and locked in position or may be released to turn freely over the screwdriver shank. Ends are insulated from each other. Replaces Nos. 30, 31, 34 and 216 Tools.....	6 $\frac{3}{4}$
287	A flat steel blade with a slot at one end which is bent up at an angle of 15 degrees. Has wood handle. Intended for sewing switchboard cable in run.	5 $\frac{5}{8}$
311	A double ended socket wrench for use on $\frac{3}{8}$ in. and $\frac{7}{16}$ in. hexagonal nuts, having slots at either end for inserting a screwdriver.	2 $\frac{5}{8}$
410A } 410B }	Hard wood wedges, for use as multiple cable lifters. Together replace the No. 93.....	18 x 2 $\frac{5}{8}$ x 1 18 x 3 $\frac{1}{2}$ x 1
R62267	For use in stripping braid from switchboard cable. Consists of a steel blade, slotted at one edge and sharpened, assembled in a metal band by means of two screws. This tool replaces the No. 288 Tool.....	5 $\frac{5}{8}$

DISTRIBUTING FRAME TOOLS

33	Socket wrench for $\frac{11}{32}$ in. hexagonal nuts on distributing frames.....	4 $\frac{11}{16}$
----	--	-------------------

DROP TOOLS

39	For adjusting shutter supports on drops.....	5 $\frac{3}{4}$ x $\frac{5}{16}$ x $\frac{5}{32}$
40	Double screw driver for use on drops. One end bent at angle of 90 degrees..	7 x $\frac{9}{32}$ x $\frac{3}{32}$

JACK TOOLS

103	Combination wrench and screw driver for adjusting No. 16 Jack Fastener....	27 x 1
113B	A steel holder with a removable steel blade having a screw driver edge at one end. Length of holder, 3 $\frac{1}{2}$ inches, length of blade, 2 $\frac{1}{2}$ inch. Intended for use in removing the underlining of jack mountings. Replaces No. 113..	4 $\frac{5}{16}$ x $\frac{3}{8}$
117	Adjusting tip and ring springs of Nos. 49 and 92 Jacks. Used with No. 118 Tool for adjusting abnormally bent ring springs of No. 92 Jack.....	7 $\frac{9}{16}$ x 1
118	With No. 117 Tool for adjusting abnormally bent ring springs of No. 92 Jacks.	7 $\frac{3}{8}$ x 1
149	Spring tweezers for use in holding wires to jack terminals while soldering. . . .	21 $\frac{1}{2}$ x 1 $\frac{3}{4}$
338	Strip of insulating material. Intended for opening the jack springs on line switchboards in step-by-step machine switching equipments for cutover purposes.....	4 $\frac{5}{64}$ x $\frac{3}{64}$
345	Consists of a parallel jaw plier handle and two tool heads, one on each jaw, arranged so that they may be rotated in turret fashion. For use on No. 92 Jacks to remove old sleeves and replace them with new sleeves.....	7 $\frac{1}{4}$ x 1 $\frac{1}{8}$
409A	Consists of a handle, two hand wheels, a cam shaft and a steel housing. For use in the field for offsetting the terminal tang of Nos. 49 and 141 Type Jack Sleeves.....	

TOOLS—Continued

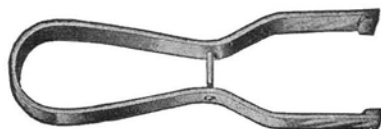

No. 90



No. 213



No. 116



No. 316

KEY TOOLS

Code No.	Use	Approximate Dimensions Inches, Overall
105	Adjusting springs on No. 453 or vertical type keys.....	$3\frac{1}{32} \times \frac{1}{4} \times \frac{15}{64}$
143	Adjusting springs of horizontal type keys.....	$4\frac{1}{4} \times 3\frac{3}{4} \times \frac{15}{64}$

LAMPS AND LAMP CAP TOOLS

116	Removing No. 2 Type Lamps.....	$3\frac{7}{8}$
319B	For removing No. 2 Type Lamp Caps and Nos. 59 and 60 Type Number Plates. Similar to the No. 58 Tool. Replaces No. 146.....	$4\frac{5}{8} \times 1\frac{7}{8}$

MESSAGE REGISTER TOOL

90	For removing caps of Message Registers.....	$6\frac{3}{16} \times 1\frac{5}{8} \times \frac{1}{2}$
----	---	--

PLUG TOOLS

213	Socket wrench for use in adjusting nuts of Nos. 103 and 137 Plugs and consists of a hardened steel socket attached to a wood handle.....	$6\frac{1}{2} \times 1\frac{1}{4}$
255	Grooved pliers for use in conjunction with Nos. 200, 201 and 202 Tools for attaching plugs to repaired cords.....	$6\frac{1}{4} \times 1\frac{25}{32} \times \frac{1}{2}$
316	Consists essentially of a hollow shaft which is equipped with a crank and contains a chuck. This shaft is provided with a collar whereby the chuck is adjusted to grip the stop shoulder of a No. 109 or No. 110 Plug. Replaces combination of Nos. 200, 201 and 202 Tools.....	$6 \times 7\frac{11}{16}$
KS-2348	Combination tool for inserting and extracting shell and connecting screws of plugs. (Replacing No. 109).....

PORTABLE TESTING EQUIPMENT

360B	Spring chuck for use in conjunction with No. 364 Tool and arranged to attach Nos. 891, 892, 893 or similar cords. Has black shell of insulating material.	$1 \times \frac{1}{4}$
360C	Spring chuck for use in conjunction with No. 365 Tool and arranged to attach Nos. 891, 892, 893 or similar cords. Has white shell of insulating material.	$1 \times \frac{1}{4}$
364	For use in conjunction with No. 360 Type Tools, in connection with portable testing equipment.....	$1\frac{15}{32} \times \frac{1}{2} \times \frac{3}{8}$
365	For use in conjunction with No. 360 Type Tools, in connection with portable testing equipment.....	$1\frac{5}{8} \times \frac{3}{8}$

TOOLS—Continued



No. 45



No. 50B



No. 419A

These Include Fuses, Heat Coils, Etc.

PROTECTOR TOOLS

Code No.	Use	Approximate Dimensions Inches, Overall
84	Wrench and screwdriver for No. 7 Type Fuse. Fits $\frac{1}{16}$ in. hexagonal nuts. . .	$2\frac{5}{8} \times 1\frac{3}{4} \times \frac{5}{8}$
361	A brush for use in cleaning protector blocks and designed to mount on the end of the No. 3-A Carrying Case by means of a screw which is provided. . .	$2\frac{3}{8} \times \frac{7}{8} \times \frac{5}{8}$
KS-2827	Pliers for use in handling heat coils of protectors.

RELAY TOOLS

43	Double wrench arranged for .195 in. and .260 in. hexagonal nuts.	$4 \times \frac{1}{2}$
45	Socket wrench for $\frac{5}{16}$ in. hexagonal armature adjusting nuts of relays. . . shank	$1\frac{3}{16} \times \frac{7}{16}$
46	Socket wrench for $\frac{3}{8}$ in. hexagonal cap nuts of No. 122 Type Relays. . . shank	$1\frac{3}{8} \times \frac{1}{2}$
48	Double socket wrench and screwdriver for adjusting armature contact screws of relays. Fits $\frac{1}{4}$ in. hexagonal nuts.	$4\frac{5}{8} \times \frac{3}{8}$
50B	For adjusting relay springs. Replaces No. 50.	$4\frac{1}{2}$
72	Double socket wrench (No. 403-A Tool) for $\frac{3}{16}$ in. and $\frac{5}{32}$ in. hexagonal nuts and screwdriver (No. 147 Tool), for adjusting armature contact screws. Similar to No. 48.	$4\frac{5}{8} \times \frac{5}{16}$
130	For use in adjusting the middle bank of springs on the No. 125 Type Relays.	$5 \times 1\frac{1}{16} \times 1\frac{1}{32}$
136B	Intended for use as a cut-over tool for holding the armature of flat type relays in either the operated or unoperated positions. Has spring construction. Replaces No. 136.	$\frac{3}{4} \times 1\frac{1}{2}$
206	An off-set screwdriver used with the No. 207 Tool for adjusting the screws holding the springs on flat type relays ("E" Types) after the relays have been mounted.	$5 \times \frac{1}{4}$
207	Used with No. 206 Tool.	$5 \times \frac{1}{4}$
221	Consists of two socket wrenches; one for $\frac{5}{16}$ in. hexagonal nuts (No. 219 Tool) fitting over the shank of a $\frac{3}{16}$ in. socket wrench (No. 220 Tool), which is arranged to fit over the screwdriver shank of the No. 35 Tool.	$7\frac{1}{16}$
259	A single piece, bar shaped, vanadium steel tool. From the side of one end extend two bevel tipped jaws. These tips are so proportioned that they can be inserted between the springs of the "A" and "E" Type Relays, thus permitting of adjusting them to the proper tension.	$5\frac{9}{16} \times \frac{9}{32}$
265B	Designed for cleaning contact points of relays. Consists of a No. 266B Tool mounted in a chuck which has a rubber handle and a magazine containing 5 spare No. 266B Tools.	$4\frac{31}{32} \times 1\frac{13}{32}$
266B	Sand blasted steel blades. Part of No. 265B Tool for cleaning contact points of relays.	$1\frac{1}{2} \times \frac{3}{16} \times .0035$
268	For adjusting contact springs of relays. For use in P.B.X. Switchboards of the No. 550 S.C. Types.	$5\frac{1}{2} \times \frac{1}{4}$
300	Intended for use to adjust relay springs. Handle covered with cotton sleeving.	$5\frac{5}{8} \times \frac{3}{16}$
324	Fibre strip. Rounded end used to hold armature of bridge cut-off relays on line switches in step-by-step dial equipments in operated position for cut-over and maintenance purposes.	$2\frac{1}{16} \times \frac{3}{4}$
340	For adjusting armature and contact air gaps on polarized relays of the Nos. 206 and 215 Types. Replaces No. 212.	$3 \times \frac{1}{4}$
349	Double closed end wrench used for adjusting nuts on "E" and No. 207 Type Relays. Engages hexagonal head nuts $\frac{3}{16}$ in. and $\frac{1}{32}$ in. across flats.	$1\frac{9}{16} \times \frac{3}{8} \times \frac{1}{16}$
419A	Consists of a tweezers-like arrangement, encased in a fibre tube, operated by a button. Intended for use in making test connections to the springs and terminals of relays and other telephone apparatus. Replaces the No. 252 Tool and No. 88 Cord Tip.	$3 \times \frac{9}{32}$

Tools—Relay—Continued

Code No.	Use	Approximate Dimensions Inches, Overall
350	For use in adjusting front contact spring of No. 118 Type Relay.....	3 ¹⁵ / ₁₆ x 1/4
360A	Spring chuck for use in conjunction with No. 361 Tool and arranged to attach Nos. 891, 892, 893 or similar cords. Has red shell of insulating material..	1 x 1/4
361B	For use in conjunction with No. 360 Type Tools to make connections with winding terminals of "A", "E" and "R" Type Relays from contact end of relay. Replaces No. 361.....	5 ²⁹ / ₃₂
373B	Handle for holding and storing No. 374 Type Tools separately or simultaneously. Replaces No. 373.....	6 ⁹ / ₁₆ x 5/8
374A	Intended for use in burnishing contact points. Can be held in jaws of No. 373 Tool.....	5 x 1 ¹⁵ / ₁₆
374B	Intended for use in burnishing contact points. Can be held in jaws of No. 373 Tool.....	2 ³³ / ₆₄ x 1 ¹⁵ / ₆₄

RESISTANCE COIL TOOLS

276	Socket wrench for adjusting mounting nuts of Nos. 18 or 19 Resistances. (Similar in design to No. 94 Tool).....	9 ³ / ₄ x 1 ¹ / ₈
277	Open end off-set wrench intended for use on mounting nuts of Nos. 18 or 19 Type Resistances when wired in position.....	9 ¹ / ₄ x 7/8

Ringer Tools

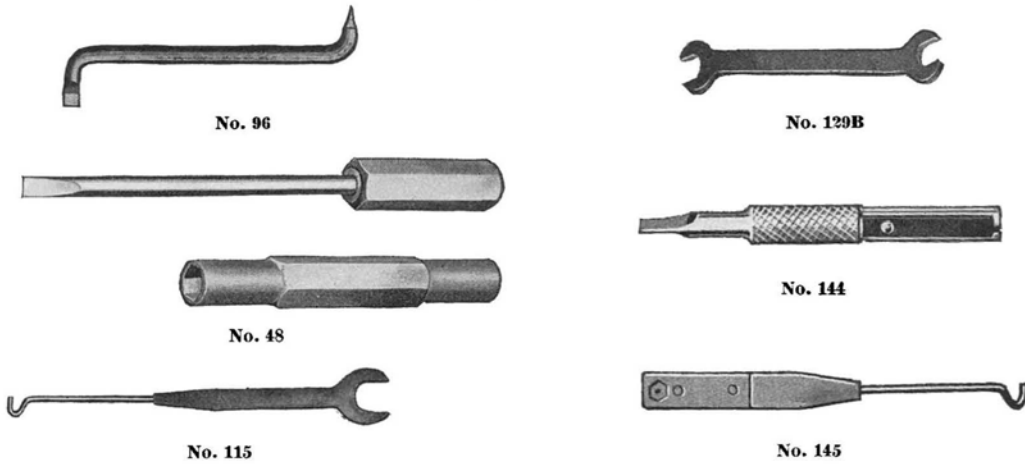

Code No.	Use	Approximate Dimensions Inches, Overall
96	Double screwdriver for ringers.....	3 ¹ / ₄ x 5/8 x 3/16
129B	Double wrench for use in adjusting armature pivot screw nuts, armature stop screws, adjusting posts and biasing spring studs on ringers. Replaces No. 129.....	2 ²⁷ / ₃₂ Offset
48	Used for adjusting Nos. 50A and 50B Selectors. Consists of a wrench and screwdriver. Will fit 1/4 inch and 1/32 inch nuts.....	
115	Used for changing Nos. 50A and 50B Selectors to call different stations. It is a small double ended tool, one end consisting of a wrench for 1/4 inch hexagonal nut; the other end a small wire hook.....	
144	Used for changing Nos. 60A and 60B Selectors to call different stations. Consists of a socket wrench and screwdriver.....	
145	Used for changing Nos. 60A and 60B Selectors to call different stations. Small double ended tool, one end consisting of a wrench for 1/8 inch hexagonal nut; the other end a small wire hook.....	

SWITCHBOARD CORD TOOLS

312B	} A set of tools for use in repairing Switchboard Cords.....	
313		
314		
315		

TOOLS—Continued**TELEPHONE SET TOOLS**

Including Transmitters, Receivers, Etc.



No. 63



Nos. 43 and 74



No. 110



No. 438A



No. 439A



No. 466A

Code No.	Use	Approximate Dimensions Inches, Overall
63	Triple wrench for use on nuts of binding posts of receivers and transmitters.	$2\frac{3}{8} \times 1\frac{5}{16}$
110	Double socket wrench for No. 20 Type Desk Stands and No. 48 Type Transmitter Arms. Fits $\frac{5}{16}$ and $\frac{9}{32}$ inch hexagonal nuts.	4 x 1
138	For adjusting stops and lugs of No. 50 Type Coin Collector.	$4\frac{15}{32} \times \frac{1}{4} \times \frac{5}{32}$
438A	Intended for use in removing and replacing transmitters, receivers and various parts on E1B Type Hand Sets.	$8\frac{3}{16} \times 3\frac{3}{16}$
439A	Same use as 438A.	$7\frac{7}{8} \times 2\frac{3}{16}$
466A	For adjusting contact springs on handset mountings, desk stands, wall sets, coin collectors and other station apparatus.	$4\frac{1}{8} \times \frac{7}{16} \times 1$

WIRE TOOLS

71	Wire skinner for use in removing the insulation from braided rubber covered wire. Has adjustable blades arranged to receive wire of different gauges.	4 x $3\frac{1}{2}$
79	Cable butter for use in turning back external braiding on switchboard cables.	
289	A steel rod one end of which is bent at right angles with the axis of the rod and formed into a hook. Has wood handle. For use in dressing skinners to relays and resistances.	8
291	Consists of a piece of music wire formed into a loop and mounted in a wood handle. Intended for pulling wires in terminal blocks.	8

MISCELLANEOUS TOOLS

74	Double wrench; same as No. 43 except arranged for $\frac{5}{32}$ in. and $\frac{1}{32}$ in. hexagonal nuts.	4 x $\frac{1}{2}$
282	Metal cap provided with knob which is free to rotate. For use on end of a pencil to operate No. 2 Type Dials.	$1\frac{31}{64} \times \frac{33}{64}$
303	For use in adjusting interrupter spring and retaining pawl on No. 200 Type Selectors.	3 x $\frac{1}{4}$
363	For use in adjusting rotor brush springs and the feeder springs of No. 200 and similar type selectors. Equipped with a handle of insulating material.	4 x $\frac{1}{2}$
370A	For use as a bank busying tool for 100 point banks in step-by-step machine switching equipments.	$3\frac{3}{4} \times 2\frac{1}{4} \times 2\frac{3}{64}$
375A	Intended for use as a make busy plug and trouble ticket holder in maintenance of connectors, selectors, line switches and repeaters of step-by-step equipment.	$3\frac{1}{32} \times 1\frac{13}{16} \times \frac{7}{16}$

TRANSMITTERS

Western Electric transmitters represent the highest development from all angles, and are recognized as standard throughout the world by leading telephone authorities.

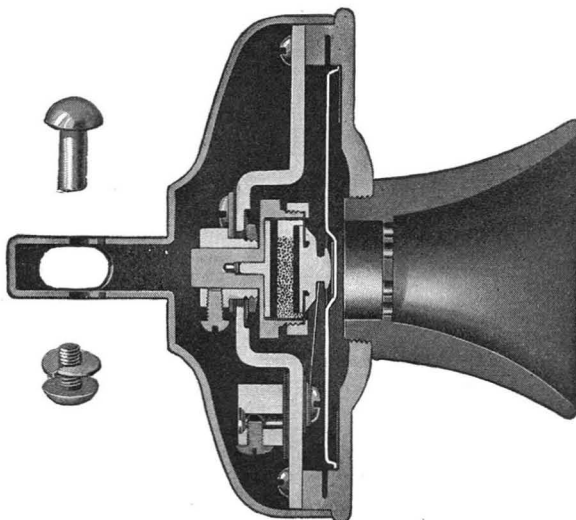

Cross Section of No. 323 Transmitter

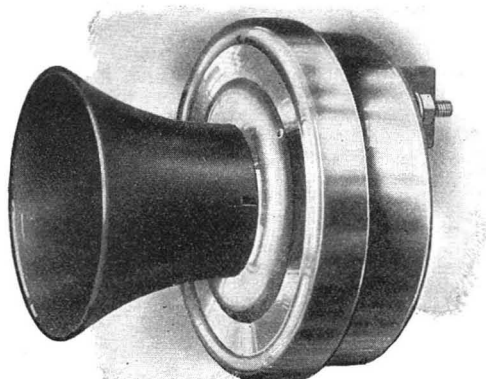

No. 312

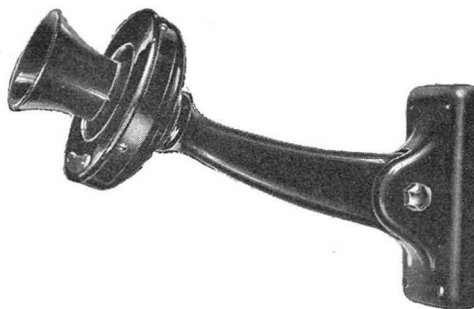

No. 353

Standard Central Battery and Local Battery Transmitters

The average resistance of the following transmitters in service is from 35 to 50 ohms.

Wall and Desk Set Types

Code No.	Replaces	Service
312	312W	For use in No. 1336 Type Mine Telephones. Treated to resist the action of moisture and fumes. Nickel plated finish with black finished brass mouthpiece. Drilled and tapped for mounting screws.
323	{ 323W	General standard transmitter for telephones and deskstands. Mounts by means of bolt and screw. Furnished in black unless nickel finish is specified.
337	{ 323BW	
	337BW	For use on long subscribers' loops. Similar to the No. 323. Black finish. Mounts by means of bolt and screw.
353	353BW	Former standard for wall type magneto telephones. Transmitter mounts on an adjustable arm bracket and has an overall length of 8¾ inches. Black finish.
354	354BW	Same as No. 353 except that the arm bracket and cords are omitted.

TRANSMITTERS—Continued

No. 232



No. 234

Standard Central Battery and Local Battery Transmitters

Listed below and on the preceding page are only a few of the many types of Transmitters obtainable for telephone service.

SWITCHBOARD TYPES

Code No.	Replaces	Description
232	232W	A switchboard operator's suspended type Transmitter having one side of circuit grounded on the frame. Arranged to be suspended by means of two transmitter cords. Has a black finish.
234	234BW	Operator's chest type Transmitter having an adjustable mouthpiece. The breast-plate is of a new design and is so constructed that it permits a proper and comfortable adjustment of the transmitter mouthpiece. Arranged for but not equipped with a No. 3 Type Transmitter Attachment. Has a black finish. Resistance approx. 40 ohms in operation.
396A	—	Operator's chest type Transmitter (equipped with a triangular breastplate similar to that used with No. 234 Transmitter) for use at magneto and common battery switchboards. Has a higher efficiency than the No. 234. Recommended for use in place of the No. 234 wherever a high resistance transmitter (approx. 175 ohms in operation) will work satisfactorily. Has a black finish. Arranged for but not equipped with a No. 3 Type Transmitter Attachment.

HAND SET TYPES

No. 244



No. 266

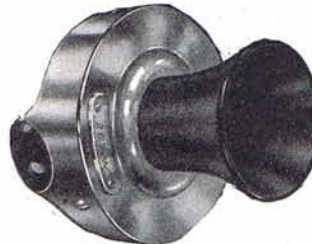

No. 267

No. 395B-3
No. 625A-3

Code No.	Replaces	Description
244*	244W	For use on No. 1001 Type Hand Sets. Has perforated metal mouthpiece secured to case by a clamping ring.
267	267W	For use on No. 1002 Type Hand Sets. Has nickel plate finish.
285*	285W	For use on No. 1001C Hand Set for train dispatching circuits. Same as No. 244 except equipped with a low resistance button.
395B-3†	—	Intended for use with the E1B Type Hand Set. Has black finish.
625A-3	—	Black finished Handset Transmitter consisting of an F1-3 transmitter unit assembled in a cast aluminum case. This Transmitter is equipped with a No. 129A Condenser to prevent cohering of the carbon due to electrical surges. It is considerably simpler and more rugged than the No. 395B-3 and is expected to afford advantages from the standpoints of aging, signaling, resistance, resistance to moisture and field maintenance. It is interchangeable with the 395B-3.

TEST SET TYPES

266	266BW	No. 1017 Type Test Set Transmitter. Mounts on back of perforated plate in test set. Has black finish and is equipped with mounting screws.
-----	-------	--

* Standard finish is black. Will be furnished when so specified in the order with a nickel finish.

† Also available in ivory, gray, old brass, statuary bronze, oxidized silver, medium gold and dark gold.

TRANSMITTER REPLACEMENT PARTS

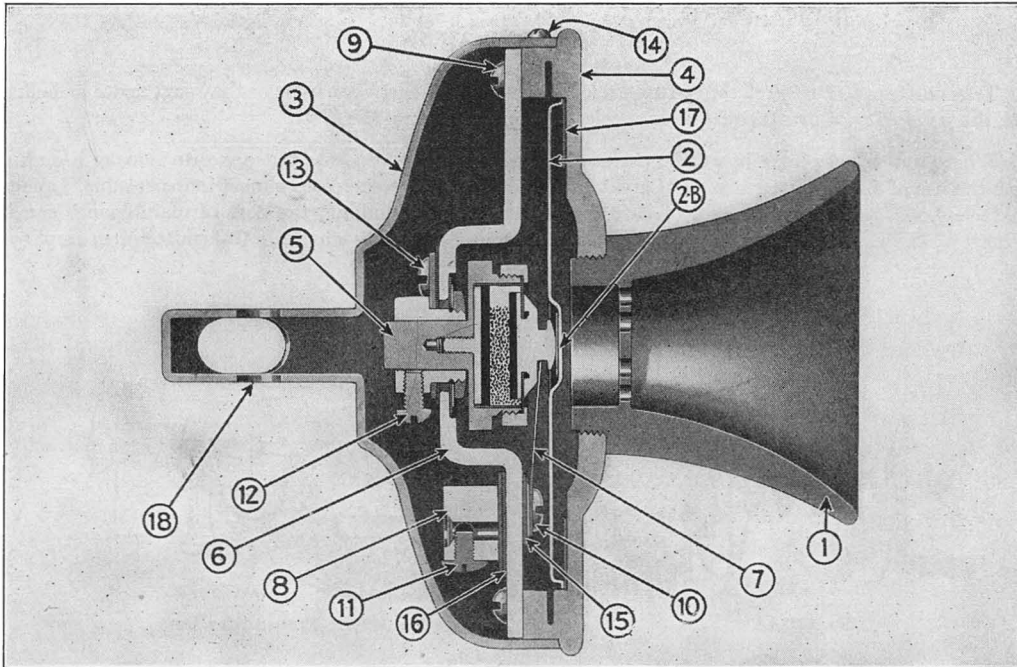

Transmitter Code Numbers

Sym- bol	Name of Part	Transmitter Code Numbers				
		232	(B) 234	244 285 312	267	323 337 353 359
1	Mouthpiece.....	P-213073	P- 91818	(Note 1)	*P-213073	†P-213073
2	Diaphragm.....	P- 90689	P- 90160	P- 90513	P- 89099	P- 97905
2B	Diaphragm Band.....	P- 89052	P- 89047	P- 89048	P- 89047
	Diaphragm Nut or Screw.....	P- 95093	P- 82278	P- 82278	P- 95093
	Insulating Disc.....	P- 95750
3	Back Case or Bell.....	P- 95228	P-220034	(Note 2)	P-220339	†P-209946
4	Transmitter Face.....	P- 90083	P- 99603	(Note 3)	P- 88325	P-207910
	Transmitter Face Ring.....	(Note 6)
5	Granular Button.....	P- 95172	P- 99377	(Note 4)	P- 90527	(Note 5)
6	Bridge and Center.....	P- 95192	P- 98453	P- 84761	P- 90527	P- 95782
7	Damping Spring.....	P- 89587	P- 86547	P- 86546	P- 88343	P- 95751
8	Terminal Block.....	P- 85472	P- 84780	P-217476
9	Machine Screw.....	P- 85787	P- 85990	P- 39656	P- 98336
10	Machine Screw.....	P-128914	P- 98334
11	Set Screw.....	P-115484
12	Adjusting Screw.....	P- 85545	P- 81389	P- 84808	P- 91810
13	Terminal Screw.....	P-116353	P-107911	P-129702
14	Rim Mounting Screw.....	P- 82291	P- 88341	P-204520
15	Washer or Insulator.....	P- 5112	P-101428	P- 99369
16	Terminal Insulator.....	P- 86769	P- 99369
17	Cloth Washer.....	P- 95195	P- 88333	P- 81697	P- 88333	P- 97904
18	Bolt P-92375; Washer P-92381 and Screw P-92378.

* P-80543 Mica Diaphragm. † P-93553 for No. 359. ‡ P-209947 for No. 353. P-222386 for No. 359.

Note 1. P-106561 for No. 312.

Note 2. P-90077 for No. 244, P-91163 for No. 285 and P-205900 for No. 312.

Note 3. P-81501 for Nos. 244 and 285, P-98074 for No. 312.

Note 4. P-85577 for Nos. 244 and 312, P-91162 for No. 285.

Note 5. P-95756 for Nos. 323, 353 and 359; P-98994 for No. 337.

Note 6. P-94935 for No. 312.

(B) Breastplate Assembly P 217431

395B-3

Mouthpiece.....	P-236253
Lock Ring.....	P-213225
Transmitter Unit.....	395B-3

396A

Breastplate.....	P-219481
Mouthpiece.....	P-209279
Transmitter Unit.....	A-1

TRANSMITTER ARMS

TELEPHONE ARMS

Transmitter arms are preferred to desk telephones by some telephone users as they save space and eliminate the possibility of overturning desk articles and disarranging papers, etc.

Where a desk telephone has to be used by two or more persons seated at opposite sides of a desk or table the use of a transmitter arm is of great convenience and in some cases almost indispensable. Where desk telephones are apt to be subjected to particularly rough handling, the cost of maintenance can be lessened by the use of transmitter arms, but this is of course true only when the transmitter arm employed is of such design as to require very little maintenance.

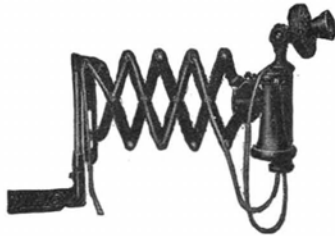

No. 1048AA

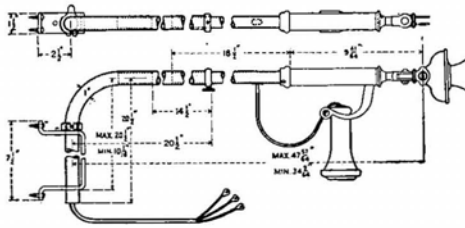

No. 1020CC Transmitter Arm

Transmitter Arms for Standard Central and Local Battery Service

The No. 1020 Type Transmitter Arm is recommended where a non-collapsible rotating type of arm is required.

The No. 1048 Type Transmitter Arm is a collapsible gate type and can be rotated in a horizontal plane. The highest grade of materials and construction are employed to assure that the arm will not sag materially even after extensive service.

These transmitter arms have rust-proof black finish with nickel-plated trimmings. In addition to the component parts listed in the following, each transmitter arm includes the No. 323 Transmitter and No. 144 Receiver.

Code No.	Trans. Arm Bracket	Consists of			Mounting	Equivalent to Deskstand
		Rec.	Trans.	Tel.		
1020CC	549 2 ft. 6 ins.	2T1A 9 7/8 ins.	550 8 ft. 0 ins.	1040AL
1048AA	2A	549 2 ft. 6 ins.	2T1A 9 7/8 ins.	550 5 ft. 6 ins.	Either side of roll top desk	1040AL
1048AB	2B	549 2 ft. 6 ins.	2T1A 9 7/8 ins.	550 5 ft. 6 ins.	Wall or side of flat top desk	1040AL
1048AC	2C	549 2 ft. 6 ins.	2T1A 9 7/8 ins.	550 5 ft. 6 ins.	Top of flat top desk	1040AL
1048BA	2A	196 2 ft. 6 ins.	2T1A 9 7/8 ins.	287 5 ft. 6 ins.	Either side of roll top desk	1040CN
1048BB	2B	196 2 ft. 6 ins.	2T1A 9 7/8 ins.	287 5 ft. 6 ins.	Wall or side of flat top desk	1040CN
1048BC	2C	196 2 ft. 6 ins.	2T1A 9 7/8 ins.	287 5 ft. 6 ins.	Top of flat top desk	1040CN

TRANSMITTER ARMS—Continued

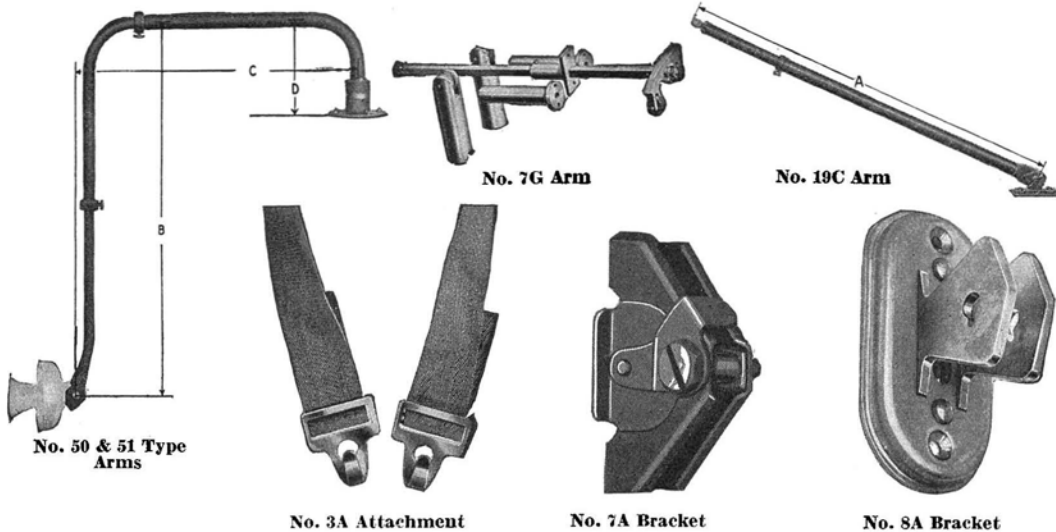

FOR SWITCHBOARDS USING SUSPENDED TRANSMITTERS

The code number does not include transmitter or cords.

Code No.	Description
7G	Consists of one arm, two cord escutcheons with tubes, and two No. 103 Cord Weights. Finished in black. Available with 7 in. or 13 in. cord escutcheon tubes. When ordering please specify which is desired.
7H	Same as 7G, except that it is available with 13 ³ / ₁₆ in. tubes only.
19C	Oxidized copper finish. Dimensions A: maximum, 28 ³ / ₄ ins., minimum, 16 ins.
19D	Oxidized copper finish. Dimensions A: maximum, 19 ⁷ / ₁₆ ins., minimum, 11 ⁵ / ₁₆ ins.

USING TRANSMITTER WITH A LUG

The code number does not include transmitter or cords.
No. 50 and No. 51 Types have a black finish.

NO. 50 TYPE						NO. 51 TYPE					
Code No.	Dimensions, Ins.				D	Code No.	Dimensions, Ins.				
	Max.	B	Min.	Min.			Max.	B	Min.	C	D
50A	25 ¹ / ₄		18 ³ / ₄	22 ¹ / ₄	14 ¹ / ₄	51B	18		12 ³ / ₄	17	10 ¹ / ₂
50B	18 ¹ / ₄		12	22 ¹ / ₄	14 ¹ / ₄						
50C	14 ³ / ₄		12	22 ¹ / ₄	14 ¹ / ₄						

* Minimum, 5¹/₄ ins., but may be increased by 1 in. steps to a maximum of 12¹/₄ ins.

Transmitter Attachments

Code No.	Color of Strap	Description
2A	Nickel plated buckle used in connection with the No. 3 Type Transmitter Attachments.
3A	Slate	These transmitter attachments consist of a tape strap equipped with two No. 2A Transmitter Attachments. They are used for supporting operator's chest type transmitters. Overall length, 21 ¹ / ₂ inches. (Used with Nos. 234 and 396A Transmitters.)
3B	Black	
3C	White	

Transmitter Brackets

These transmitter brackets will mount any Western Electric transmitter that is equipped with a mounting lug and screw, for example the 323 Transmitter.

Code No.	Finish	Description
3D	Black	For mounting old style grounded transmitters on wooden telephones. Has a stud for making the ground connection.
3E	Black	For mounting insulated transmitters. Used principally on wooden telephones.
7A	Nickel Plate	For mounting insulated transmitters in a semi-flush position on metal telephones. For example, No. 1533 Type and similar telephones.
8A	Black	For mounting insulated transmitters on wooden telephones. For example, No. 1317 Type Telephones.

TRANSMITTER ARM BRACKETS

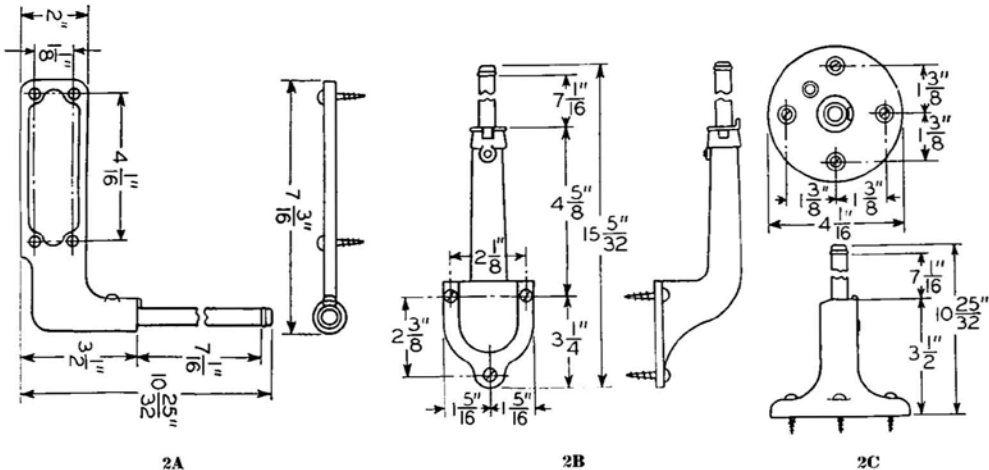

Transmitter Arm Brackets

Code No.	Description	Dimensions, Inches		Use
		Length of Rod	Overall Length	
2A	Consists of an iron base equipped with a steel rod about which the arm rotates	$7\frac{1}{16}$	$10\frac{25}{32}$	Mounts on the side of roll top desks.
2B	Same as the No. 2A except equipped with a collar assembled on the rod for the purpose of stopping the rotation of the transmitter arm in any one of the four predetermined positions.	$7\frac{1}{16}$	$15\frac{5}{32}$	Mounts on wall or side of flat top desks.
2C	Similar to the No. 2A.	$7\frac{1}{16}$	$10\frac{25}{32}$	Mounts on the top of a flat top desk.

WIRE**LACQUER TREATED**

This Lacquer Treated Wire is especially adapted for use in local and toll switchboards and has many advantages over the old style wax impregnated type. Some of these advantages are as follows:

1. Eliminates wax as a fire hazard.
2. Eliminates insulation fraying at terminals.
3. Does not collect dirt.
4. Colors are brighter after long periods of service.
5. Special purified textiles used.

LACQUER TREATED SWITCHBOARD WIRE**Double Cotton Insulation**

Obtainable in 14, 16, 19, 22 and 24 Gauges; single, paired, triple or quadded; also in all standard color combinations (See "Cable").

Note. Single silk double cotton wax impregnated switchboard wire is also available in all standard sizes.

LACQUER TREATED LOCAL CABLE WIRE (TOLL)**Double Silk, Single Cotton Insulation**

Obtainable in 14, 16, 19, 22 and 24 Gauges; single, paired, triple or quadded; also in all standard color combinations (See "Cable"). Designed principally for use in local cable forms in toll and telegraph circuits.

QUADED LACQUER TREATED TOLL SWITCHBOARD WIRE**DOUBLE SILK, SINGLE COTTON INSULATION****(Multiple Twin Only)**

Obtainable in 22 B. & S. Gauge only; available in standard colors of quads (See "Cable"). Designed principally for use in toll circuits. It has a heavier insulation than those outlined above and also is composed of a twin construction which provides for minimum crosstalk when used in phantom circuits.

ENAMEL, SILK, COTTON BRAIDED, WAX IMPREGNATED WIRE

Obtainable in 14, 16, 19, 20 and 22 B. & S. Gauges; single, paired, triple, quadruple or quintuple.

CROSS-CONNECTING OR DISTRIBUTING FRAME**Jumper Wire****"L" TYPE**

This Wire, usually known as Jumper Wire, is made in single, twisted pair, triple or quadruple conductors.

This Wire is made in No. 20 or No. 22 B. & S. Gauge conductors; tinned copper enameled double silk and cotton served lacquer treated conductors. Furnished in 1500 foot coils.

Code No.	Size (B. & S. Gauge)	No. of Conductors	Colors	Replaces
L20S	20	1	Brown	E20S & E22S
L20P	20	(a)2	Brown, *Black	E20P
L20T	20	(a)3	Brown, *Black, *Red	E20T
L20F	20	(b)4	Brown, *Red, *Black, *Green	E20F
L22P	22	(a)2	White, Black	E22P
L22T	22	(a)3	White, Black, Red	E22T
L22F	22	(a)4	White, Red, Black, Green	E22F

* Has a single thread brown tracer.

(a) Conductors are twisted together in a spiral.

(b) The brown and black conductors form one twisted pair; the red and green conductors form another twisted pair and the two pairs are twisted together to form a quad.

THIS PAGE INTENTIONALLY BLANK

GraybaR Supplies

THIS PAGE INTENTIONALLY BLANK

BATTERIES AND SUPPLIES*

EDISON PRIMARY CELLS

Edison Primary Cells are furnished in capacities ranging from 75 to 1000 ampere hours. The sizes best adapted for telephone work are the 75, 250, and 500 ampere hour types.

The characteristics of this battery, which make it particularly well suited for telephone service, are: uniform voltage under continuous discharge; extremely low and constant internal resistance; freedom from depreciation when the circuit is open; long life, with no attention between renewals; indicator panels in plates, which accurately show the approach of exhaustion and thus make it possible to maintain any circuit indefinitely without a battery failure.

The initial open circuit voltage of all Edison Primary Cells is 0.9. The closed circuit voltage averages 0.60 to 0.65 depending on the rate at which the cells are discharged and the degree of exhaustion.

TYPE 75 EDISON PRIMARY CELL

Capacity, 75 ampere Hours

With round glass jar. Size overall 3 x 7½ inches.

This cell was developed to meet the demand for a low capacity unit, constructed along the lines of standard cells of greater capacity and established reliability.

At a continuous discharge of 100 milliamperes it will deliver 80 ampere hours to a cut-off voltage of 0.6. It is capable of sustained discharges up to 650 milliamperes or intermittent up to 1 ampere.

It is particularly well suited for telephone work and for all classes of service where dependable capacity and uniform voltage reliability are necessary requisites.

In this type only it is customary to discard the entire battery when it exhausts and replace it with new cells.



Type 75 Cell

Type
75

Description
Complete Cell

TYPE S-252 EDISON PRIMARY CELLS

Capacity, 250 ampere Hours

With rectangular heat-resisting glass jar. Size over all, 3½ x 6 x 12½ inches. Inside dimensions of jar only, 2⅞ x 5¼ x 10 inches.

In this cell (as well as the type S-502) the active materials are finely balanced, the proportioning of electrodes to electrolyte being practically perfect. The element is carried high in the jar, clear of the saturated solution, and the cell occupies minimum space. It is recommended for railway telephone dispatching transmitters; inter-communicating telephones; self-winding and program clocks; fire and burglar alarm systems or any service where the capacity is sufficient for one or more years' operation. Complete cells are purchased for initial installations—subsequently only renewals.

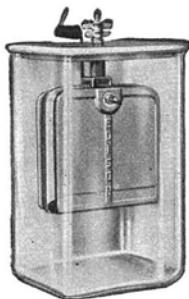

Type S-252 Cell

Initial open circuit voltage, 0.9. Average closed circuit voltage, 0.6 to 0.65 per cell. Maximum recommended continuous current, 1 ampere. Maximum recommended intermittent current, 1.5 amperes.

Type	Description	Type	Description
S-252	Complete Cell	S-250	Separate Parts
252	Jar	250	Complete Renewal
252	Cover	250	Element, Assembled
...	Wing Nuts and Washers	250	Caustic Soda
			Oil

*Dry Batteries are listed on page 386.

BATTERIES AND SUPPLIES**Edison Primary Cells****TYPE S-302 EDISON PRIMARY CELL****Capacity, 300 ampere Hours**

With rectangular heat resisting glass jar. Dimensions the same as the S-252.

This cell is designed for the same classes of work in which the S-252 is used. There is no difference in over all dimensions but the cell is provided with more active material and is recommended for service in which a capacity of 300 ampere hours is desirable.

Type	Description	Type	Description
S-302	Complete Cell	S-302 Separate Parts	Complete Renewal
302	Jar	S-300	Element, Assembled
302	Cover	300	Caustic Soda
...	Wing Nuts and Washers	300	Battery Oil

TYPE S-502 EDISON PRIMARY CELL**Capacity, 500 ampere Hours**

The 500 ampere hour cells are extensively used for the operator's transmitter in connection with magneto switchboards, or for any service where the consumption is sufficient to justify the use of a battery of this capacity. When a cell exhausts, the active materials are replaced and the battery is restored to its original condition. The ampere hour cost of active materials (designated as a renewal) are substantially lower for this cell than for any other commercial primary battery. The capacity is so consistently delivered that where the daily consumption can be computed the life of each set of renewals can be accurately determined.



Type S-502 Cell

Initial open circuit voltage, 0.9. Average closed circuit voltage, 0.6 to 0.65 per cell. Maximum recommended continuous current, 2 amperes. Maximum recommended intermittent current, 3 amperes.

In addition to transmitter and interrupter operation this battery is suitable for all important service where the load falls within the recommended limits. It is frequently used as a standby battery for low voltage apparatus, where the load is normally carried by a rectifier, owing to the manner in which it simplifies the maintenance problem.

With rectangular heat-resisting glass jar. Size over all, $5\frac{1}{2} \times 6\frac{1}{2} \times 12\frac{1}{4}$ inches. Inside dimensions of jar only, 5 x 6 x 10 inches.

Type	Description	Type	Description
S-502	Complete Cell	S-500 Separate Parts	Complete Renewal
502	Jar	S-500	Element, Assembled
502	Cover	500	Caustic Soda
...	Wing Nuts and Washers	500	Oil

BATTERIES AND SUPPLIES

EXIDE STORAGE BATTERIES

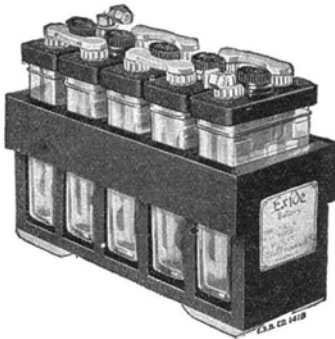

BTMH Chloride Type

Exide storage batteries are made in a wide variety of sizes and types to meet the requirements of various kinds of power applications where a reliable source of direct current at steady voltage is required either constantly, intermittently or to tide over occasional interruptions in the normal power supply.

There are three types of Exide Batteries made for these requirements, the Chloride type, the Pasted Plate type and the well-known Ironclad type.

The Chloride type, which is essentially different in design and construction from the batteries popularly known by the public, is built primarily for durability. Its famous Manchester positive plate and its equally famous Box Negative plate have earned for it so enviable a reputation that where long life and freedom from care and attention, together with absolute dependability, are the deciding factors, this type invariably receives the first call.

The Pasted Plate type furnishes greater capacity in a given space than the Chloride type. Where this consideration is important and operating conditions are favorable, the results obtained justify the selection of this type of battery.

The Ironclad is the third type. The outstanding feature of the Ironclad type is its unique positive plate, which is totally different in construction from that of any other positive plate. In performance and longevity this type of Exide is second only to that of the famous Chloride.

Types BTMH, CTMH, PTMH, ETMH, BTE, and KZHG are furnished in painted wooden crates, all but the first two types being equipped with carrying handles. Each crate assembly contains one cell equipped with pilot balls which roughly indicate the state of charge.

Exide Batteries are shipped charged and filled with electrolyte, ready for service.

Type and Size	Catalog Number	Capacity in Amp. Hrs. at 8-hr. rate to 1.75 volts (per cell)	Overall Dimensions in Inches			Approx. Weight in lbs. Packed for L. C. L. Shipment
			Length	Width	Height	
11 cells BTMH- 2 (1 row)	21312	6	26 ⁵ / ₈	4 ⁵ / ₁₆	9 ⁷ / ₈	81
11 cells CTMH- 2 (1 row)	21302	12	29 ⁷ / ₁₆	7 ¹ / ₂	11 ⁷ / ₈	156
11 cells PTMH- 2 (1 row)	21368	24	33 ³ / ₈	8	16 ⁵ / ₈	249
11 cells ETMH- 2 (2 rows)	21361	36	20 ⁹ / ₁₆	20 ¹ / ₂	16 ³ / ₈	368
11 cells BTE - 5 (1 crate)	20189	14.4	21 ⁷ / ₈	12	9 ⁷ / ₈	148
11 cells BTE - 7 (1 crate)	20190	21.6	21 ⁷ / ₈	12	9 ⁷ / ₈	160
11 cells KZHG - 7 (1 crate)	21268	26.6	21 ⁷ / ₈	12	9 ⁷ / ₈	160
2 cells BI - 5†	18508	14.4	8 ⁵ / ₈	3 ¹ / ₈	7 ⁷ / ₈	15
2 cells BI - 9†	18509	23.8	8 ⁵ / ₈	4 ⁷ / ₈	7 ⁷ / ₈	23
1 cell DMGO- 3	22559	20	4 ¹¹ / ₁₆	8 ¹ / ₁₆	14 ³ / ₈	32
1 cell DMGO- 5	22282	40	4 ¹¹ / ₁₆	8 ¹ / ₁₆	14 ³ / ₈	37
1 cell DMGO- 7	22283	60	5 ¹⁵ / ₁₆	8 ¹ / ₁₆	14 ³ / ₈	46
1 cell DMGO- 9	22293	80	7	8 ¹ / ₁₆	14 ³ / ₈	56
1 cell EMGO- 5	21409	80	5 ¹¹ / ₁₆	10 ³ / ₁₆	17 ¹ / ₄	69
1 cell EMGO- 7	21410	120	7 ¹ / ₈	10 ³ / ₁₆	17 ¹ / ₄	90
1 cell EMGO- 9	21411	160	7 ¹ / ₈	10 ³ / ₁₆	17 ¹ / ₄	99
1 cell FMGO- 9	22560	320	10 ¹¹ / ₁₆	14 ⁷ / ₁₆	22	231
1 cell FMGO-11	22561	400	10 ¹¹ / ₁₆	14 ⁷ / ₁₆	22	246
1 cell FMGO-13	22562	480	12 ³ / ₁₆	14 ⁷ / ₁₆	22	290
1 cell EOGO - 5	19283	80	5 ¹¹ / ₁₆	10 ³ / ₁₆	16 ³ / ₁₆	52
1 cell EOGO - 7	19284	120	5 ¹¹ / ₁₆	10 ³ / ₁₆	16 ³ / ₁₆	56
1 cell EOGO - 9	19285	160	5 ¹¹ / ₁₆	10 ³ / ₁₆	16 ³ / ₁₆	61
1 cell EOGO -11	19286	200	7 ¹ / ₈	10 ³ / ₁₆	16 ³ / ₁₆	75
1 cell EOGO -13	19287	240	7 ¹ / ₈	10 ³ / ₁₆	16 ³ / ₁₆	80
1 cell FOGO -15	22190	532	10 ¹¹ / ₁₆	14 ⁷ / ₁₆	22	230
1 cell FOGO -17	22191	608	10 ¹¹ / ₁₆	14 ⁷ / ₁₆	22	237
1 cell FOGO -19	22192	684	10 ¹¹ / ₁₆	14 ⁷ / ₁₆	22	245
1 cell FOGO -21	22193	760	12 ³ / ₁₆	14 ⁷ / ₁₆	22	282
1 cell FOGO -23	22194	836	12 ³ / ₁₆	14 ⁷ / ₁₆	22	290

Note. Cells of greater capacity than listed above are available in sealed glass jar assembly up to 1064 ampere hours at the 8-hour discharge rate.

* Prices do not include pilot balls, except on Types BTE, KZHG and BI. One set of these indicators is regularly furnished with these types. Prices of cells of types DMGO, EMGO, FMGO, EOGO and FOGO include the necessary bolt connectors, but do not include intercell connectors.

† Exide-Ironclad Type.

BATTERIES AND SUPPLIES**Intercell Connectors**

Intercell connectors are not a part of the battery and are ordered separately. Detail data is as follows:

Type of Cell	Lead Plated Copper Intercell Connectors		Lead Plated Copper Intercell Connectors*		Type of Cell	Lead Plated Copper Intercell Connectors		Lead Plated Copper Intercell Connectors*	
	No. of Pieces per Connector	Cat. No. **	No. of Pieces per Connector	Cat. No. **		No. of Pieces per Connector	Cat. No. **	No. of Pieces per Connector	Cat. No. **
DMGO-3	1	17122	1	17123	EOGO-5	1	19440	1	19441
DMGO-5	1	17122	1	17123	EOGO-7	1	19440	1	19441
DMGO-7	1	18484	1	18485	EOGO-9	2	19505	1	19506
DMGO-9	1	17326	1	17327	EOGO-11	2	19298	1	19299
EMGO-5	1	19440	1	19441	EOGO-13	2	19298	1	19299
EMGO-7	1	18793	1	18794	FOGO-15	8	19347	8	19348
EMGO-9	2	19298	2	19299	FOGO-17	8	19347	8	19348
FMGO-9	4	19302	4	19303	FOGO-19	8	19347	8	19348
FMGO-11	4	19302	4	19303	FOGO-21	8	19347	8	19348
FMGO-13	4	19302	4	19303	FOGO-23	8	19347	8	19348

* For use with cells placed behind the uprights on racks.

** Catalog Numbers include number of pieces necessary for one connector.

Old type open batteries and repair parts are still obtainable.

Wood racks for DMGO, EMGO and FMGO can be furnished for batteries of from ten to sixty-four cells capacity. For details and prices for all repair parts including thermometers, hydrometers, electrolyte, inter row and inter tier connectors as well as other miscellaneous parts, consult with the nearest Graybar House who will gladly make recommendations for your battery requirements.

Tungar Battery Chargers**HALF WAVE TUNGARS FOR SYSTEMS USING DUPLICATE BATTERIES AND MISCELLANEOUS APPLICATION**

In many exchanges, it is customary to have duplicate sets of storage batteries of 11 to 12 cells each. One battery is connected to the telephone circuit while the other is being charged. For this type of work the half wave charger should be selected on account of its low cost and simplicity of construction.

No. 6RB14Y1 is the smallest high voltage Tungar. It is used chiefly for trickle charging. No provision is made for manual control of the outfit, but it is so designed that it has a high degree of inherent regulation. With battery voltage of 120 it will deliver a charging rate of .8 amperes tapering to .6 at 150 volts and .4 amperes at 175 volts.

No. 204170 has two secondary taps on the transformer permitting maximum output of 2.5 amperes at either 24 or 30 volts. An adjustable resistance of approximately 6 ohms in the set permits adjusting the charging rate from 2.5 amperes maximum down to a minimum of about .5 amperes.

No. 199717 is similar to No. 204170 but has a wider range of D.C. voltage. Three taps on the transformer secondary permit adjustment of the output of 2.5 amperes at 40, 50 or 60 volts.

No. 6RB4B8 is similar to the 6RB6B7 but for use on half wave and is not adaptable to filtered circuits. Both primary and secondary circuits are controlled simultaneously by a single snap switch.

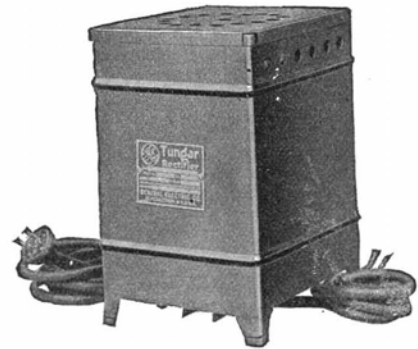

No. 204170

Catalog No.	D.C. Volts	D.C. Amps.	Cycles	Volts	Renewal Bulb	Number of Cells
6RB14Y1	120-175	0.8-0.4	60	115	16X 897	50-66
204170	24-30	1.25-2.5	60	115	195528	9-12
199717	40-50-60	1.25-2.5	60	115	189048	16-24
6RB4B8	6-72	6	60	115	189049	8-24

BATTERIES AND SUPPLIES

Tungar Battery Chargers

FULL WAVE TUNGARS (NOISELESS TYPE) FOR SYSTEMS

USING SINGLE BATTERY

These outfits are designed to charge batteries while operating on the telephone circuit. They are all full wave Tungars and include a direct-current reactance which smooths out the charging wave sufficiently to prevent an objectional noise in the receivers.

Catalog No.	D.C. Volts	D.C. Amps.	Cycles	A.C. Volts	No. of Cells Rectifier Will Charge	Renewal Bulb
244708	30	.3-.5	60	105-125	11-12	199698
3049455	19-52	1-3	60	105-125	9-24	12X825
6RB6B7	6-72	12	60	105-125	9-24	189049

No. 244708 is the smallest outfit. It is intended for continuous trickle charging on small P.B.X.'s. An adjustable resistance in the secondary circuit permits adjusting the charging rate from .3 to .5 amperes.

No. 3049455 can be used wherever a full wave, filtered output up to 3 amperes is required. Terminal board is located inside left-hand door and contains six sets of secondary taps and permits adjustment for operation on 9 to 24 cells of battery. An ammeter provides means to indicate charging rate.

Model No. 6RB6B7 Tungar is used extensively for float charging telephone batteries in all sizes of telephone exchanges as well as on private branch exchanges where a high charging rate is desired. When used to float charge the telephone battery external reactance catalog No. 3126680 should be used in conjunction with the Tungar in order to eliminate objectionable hum from the telephone circuit. The catalog No. 3126680 reactance must be ordered separately. Where charging rates of more than 12 amperes are required, two or more of these outfits may be connected in parallel to obtain the necessary charging rate. The output is controlled by means of coarse and fine adjustment plugs, and two ammeters are provided on the outfit to indicate the charging rate. This Tungar has a nominal rating of 6-72 volts and is used extensively for charging 12-24 three-cell batteries. However, when used with the catalog No. 3126680 reactance, this Tungar is not recommended for more than 65 volt DC, as the output is cut down by the high inductance of the filter.

These outfits are designed primarily to meet the requirements of inter-communicating systems and private branch exchanges. The outfits are used wherever a full wave, filtered output of 2 and up to 6 amperes is required. These outfits contain a suitable filter reactance, the design of which will furnish extremely quiet operation on telephone circuits.

A terminal board conveniently located just inside the door contains six sets of secondary taps and permits adjustment for operation on 11 to 24 cells of batteries. A rheostat controlled from the panel gives very close adjustment of the charging rate for the 2 ampere and the 6 ampere size outfits. A high grade ammeter is furnished to indicate the rate.



No. 6RB6B7



6RB10C5

Catalog No.	D.C. Volts	D.C. Amps.	Cycles	A.C. Volts	No. of Cells Rectifier Will Charge	Renewal Bulb
6RB23C1	19-52-65	2-2-0.9	60	115	11 to 24	16X897
6RB23C2	19-52-65	2-2-0.9	60	230	11 to 24	16X897
6RB10C5	19-52-65	6-6-1.75	60	115	11 to 24	45X674
6RB10C6	19-52-65	6-6-1.75	60	230	11 to 24	45X674

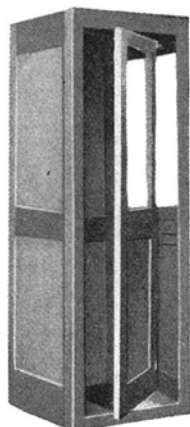
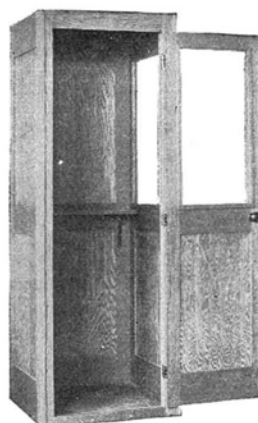
BOOTHS—TELEPHONE**No. 3 Booth Semi-closed****No. 4 Booth—Open****No. 3 Type Receding Door Telephone Booths**

This booth is particularly desirable where space, along with low cost, is an important factor. Although not as heavily constructed as the Nos. 1 and 2 types this booth presents a very substantial appearance. When open the receding door projects only 6 inches beyond the face of the booth and operates by a patented arrangement of hardware that is noiseless, fool-proof and operates exceptionally smooth. No grooves in the floor necessary for the operation of this door.

The No. 3 Booth is 83½ inches high by 28½ inches wide by 29¼ inches deep and is furnished as follows:

Code No.	Material	Finish	Description
3A	Plain oak	Medium oak	1 glass panel in door, and 1 glass in right side.
3B	Birch	Dark mahogany	1 glass panel in door, and 1 glass in right side.
3C	Birch	Light mahogany	1 glass panel in door, and 1 glass in right side.
3D	Plain oak	Medium oak	1 glass in door, 1 glass in right side, 1 glass in left side.
3E	Birch	Dark mahogany	1 glass in door, 1 glass in right side, 1 glass in left side.
3F	Birch	Light mahogany	1 glass in door, 1 glass in right side, 1 glass in left side.
3G	Plain oak	Medium oak	1 glass panel in door only.
3H	Birch	Dark mahogany	1 glass panel in door only.
3J	Birch	Light mahogany	1 glass panel in door only.

No. 4 Type Swinging Door Telephone Booths

The same size as the No. 3 type, this booth is constructed to meet the demand of those who require a substantial, simple telephone booth at low cost. A feature of this type booth is the fact that both the right and left sides are interchangeable. The backs of these booths are reinforced, suitable for mounting either a wall telephone or coin collector set. The swinging door is equipped with substantial heavy brass hardware.

The No. 4 type booth is furnished as follows:

Code No.	Material	Finish	Description
4A	Plain oak	Medium oak	1 glass panel in door, 1 glass in right side.
4B	Birch	Dark mahogany	1 glass panel in door, 1 glass in right side.
4C	Birch	Light mahogany	1 glass panel in door, 1-glass in right side.
4D	Plain oak	Medium oak	1 glass in door, 1 glass in right side, 1 glass in left side.
4E	Birch	Dark mahogany	1 glass in door, 1 glass in right side, 1 glass in left side.
4F	Birch	Light mahogany	1 glass in door, 1 glass in right side, 1 glass in left side.
4G	Plain oak	Medium oak	1 glass in door only.
4H	Birch	Dark mahogany	1 glass in door only.
4J	Birch	Light mahogany	1 glass in door only.

CLOCKS

Calculagraph—Time Records



**Style A
On Pedestal**

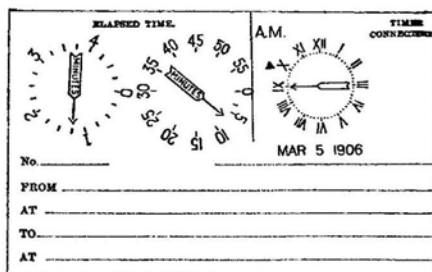

Style C

The calculagraph is an elapsed time recorder. The machine is provided with two levers; by operating one when a connection is established and the other when the conversation is finished, a card record is obtained similar to that shown above. Two models are made; the No. 6 spring driven type calculates and prints the elapsed time in minutes and quarter minutes and records the time of day. The new No. 30 is constructed to run by a self-starting, synchronous motor, and makes accurate records of elapsed time to as close a division as one second for a maximum period of thirty minutes.

Tests of the No. 30 records for a period of several months in one exchange have shown substantial increases in revenue from overtime calls and greater ease in reading the records. The record card reproduced above is from the new No. 30 model and shows a case in which a connection lasting 5 minutes and 22 seconds was made at 7:15 P.M.

Each model is supplied in two styles as illustrated. Calculagraph shelves or sections can be supplied for mounting these instruments at either the left or right hand ends of switchboards in cases where it is not convenient to use either style, with or without a pedestal.

A Model 6 Calculagraph, if in good operating condition, can be converted to the Model 30 at a moderate cost, and where regulated, alternating current is available, this type calculagraph will prove a most profitable investment.

Model No.	Description
6	Style A or C (state which is desired)
30	Style A or C (state which is desired)
	Pedestal for use with Style A (adjustable height 26-40 inches)
	Ribbon for calculagraph (furnished in blue unless otherwise ordered)

Chronoscope



Chronoscope

The chronoscope is a convenient and inexpensive instrument for measuring toll or other timed telephone service. It is 3½ inches in diameter at the base and has a six-minute clock dial face. The case is of metal with an oxidized finish.

The lever at the top is used when starting and stopping the timing of the call, which may be continuous or a total of several periods. The lever at the right-hand side of the device returns the hand to zero. In the model listed, a bell is automatically rung when the hand passes the three-minute mark and again at the end of six minutes.

When so desired, an instrument giving a warning signal a few seconds before the expiration of one and three minute periods, can be supplied without additional cost.

List No.	Description
99½	Signals at 3 and 6 minutes

AUTOCALL PAGING SYSTEMS

(FULLY AUTOMATIC TYPE)

Application

The most common use of Autocall Paging System is to locate someone who does not hear his telephone. When a customer calls—when an important telephone message is received—when long distance asks for the man—when the chief is wanted out in the plant—when one executive needs to consult with another—when an emergency arises—when someone's valuable time is being wasted because someone else cannot be located—in these and dozens of other situations, some of which arise every day in every organization, the Autocall renders invaluable service.

Construction and Operation

The Autocall Central code sending devices are motor driven and fully automatic in operation. A single operation on the part of the operator actuates the central. The centrals are of the combination limited or continuous call type as required.

The Autocall Central code sending devices have two moving contacts. The operation is entirely electrical. The motor has a variable speed governor and the gearing and complete assembly is cushioned on springs, making for silent and vibrationless action. The coding arrangement is so constructed that a minimum of stroking is required. On certain models, a saving of up to 40% in strokes is made over other similar devices.

The latest No. 31 line of centrals incorporates the selective call feature, which provides a means of telling in a general way the nature of the call in addition to calling the person wanted.

Additional Features

Such features as Remote Control, Duo-Control, Automatic Dismissal or Emergency Service, Night Watchman Call, etc., can be furnished.

Power Supply

The systems are designed for operation on A.C. or D.C. from voltages of 10 volts to 200 volts. The lighting or power service, transformers or batteries can be utilized as a source of supply.



Chime
Signal

Signals

The Bells are of the "underdome design" and can be furnished in single stroke or vibrating type (interchangeable). The standard bell sizes are 4", 6", 8" and 10" and 12". Special bell shell metal effects maximum sound results. The bells are of the solenoid type with a free action plunger (Hammer). Low current consumption consistent with clear cut signals is an attractive feature.

Two types of chime signals are available, namely, the Executive and Xylotone types. The Executive type has a hand tempered wafer bar, each signal being tuned to the note of "A". The Xylotone signal is the usual flat bar type. Both signals are readily adjustable.

In addition to above signals, sirens and whistles can be furnished also lamp signals for silent code call such as desk lamp signals for Hospitals, Private Offices, etc.

Relays

A line of specially constructed light and heavy duty relays for paging system uses are offered.

Cylinder Bellows



No. 1	20 inches		No. 3	24 $\frac{3}{4}$ inches
No. 2	22 $\frac{3}{8}$ inches		No. 4	25 $\frac{1}{8}$ inches

Designed for cleaning motors, generators, telephone switchboards, looms, and other machinery that cannot be reached with a cloth or brush. Constructed of composition fibre with wood mounting and will not short circuit electrical apparatus. Made in four sizes.



Central Sending Station

GRAYBAR INTER-PHONES

NO. 1 INTER-PHONE SYSTEM

SELECTIVE RINGING—SELECTIVE TALKING



No. 1324C-12

Wall Type:

No. of Buttons	Code No.	Mounting	Height	Dimensions—Inches			Outlet Box		
				Housing Width	Depth	Height	Width	Depth	
6	1324C-6	Surface	10	6 $\frac{3}{8}$	3	
12	1324C-12	Surface	10	6 $\frac{3}{8}$	3	
16	1324C-16	Surface	14 $\frac{5}{16}$	7 $\frac{1}{16}$	3	
20	1324C-20	Surface	14 $\frac{5}{16}$	7 $\frac{1}{16}$	3	
24	1324C-24	Surface	14 $\frac{5}{16}$	7 $\frac{1}{16}$	3	
16	1355C-16	Flush	14 $\frac{1}{2}$	6 $\frac{7}{8}$...	12 $\frac{7}{8}$	5 $\frac{1}{4}$	3 $\frac{11}{32}$	
20	1355C-20	Flush	14 $\frac{1}{2}$	6 $\frac{7}{8}$...	12 $\frac{7}{8}$	5 $\frac{1}{4}$	3 $\frac{11}{32}$	
24	1355C-24	Flush	14 $\frac{1}{2}$	6 $\frac{7}{8}$...	12 $\frac{7}{8}$	5 $\frac{1}{4}$	3 $\frac{11}{32}$	

Desk Stand Type:



No. 1355C-16

No. of Buttons	Code No.	Desk Stand	Cord, Ft.	Includes Key Box	Dimensions—Inches		
					Width	Length	Depth
6	6016D-6	1140BE	5 $\frac{1}{2}$	328C-6	5	7 $\frac{1}{2}$	2 $\frac{5}{8}$
12	6016D-12	1140BE	5 $\frac{1}{2}$	328C-12	5	7 $\frac{1}{2}$	2 $\frac{5}{8}$
16	6016D-16	1140BE	5 $\frac{1}{2}$	328C-16	5 $\frac{3}{4}$	10 $\frac{3}{4}$	2 $\frac{5}{8}$
20	6016D-20	1140BE	5 $\frac{1}{2}$	328C-20	5 $\frac{3}{4}$	10 $\frac{3}{4}$	2 $\frac{5}{8}$
24	6016D-24	1140BE	5 $\frac{1}{2}$	328C-24	5 $\frac{3}{4}$	10 $\frac{3}{4}$	2 $\frac{5}{8}$

Desk Cradle Type:

No. of Buttons	Code No.	Hand Set and Cradle	Cord, Ft.	Includes Key Box	Dimensions—Inches		
					Width	Length	Depth
6	6116CH-6	1116CH	5 $\frac{1}{2}$	328C-6	5	7 $\frac{1}{2}$	2 $\frac{5}{8}$
12	6116CH-12	1116CH	5 $\frac{1}{2}$	328C-12	5	7 $\frac{1}{2}$	2 $\frac{5}{8}$
16	6116CH-16	1116CH	5 $\frac{1}{2}$	328C-16	5 $\frac{3}{4}$	10 $\frac{3}{4}$	2 $\frac{5}{8}$
20	6116CH-20	1116CH	5 $\frac{1}{2}$	328C-20	5 $\frac{3}{4}$	10 $\frac{3}{4}$	2 $\frac{5}{8}$
24	6116CH-24	1116CH	5 $\frac{1}{2}$	328C-24	5 $\frac{3}{4}$	10 $\frac{3}{4}$	2 $\frac{5}{8}$

Hand Set Type:



No. 6139C-12

No. of Buttons	Code No.	Hand Set	Cord, Ft.	Includes Hand Set Hanger	Includes Key Box	Dimensions—Inches		
						Width	Length	Depth
6	6016HR-6	1003R	6	141A	328C-6	5	7 $\frac{1}{2}$	2 $\frac{5}{8}$
12	6016HR-12	1003R	6	141A	328C-12	5	7 $\frac{1}{2}$	2 $\frac{5}{8}$
16	6016HR-16	1003R	6	141A	328C-16	5 $\frac{3}{4}$	10 $\frac{3}{4}$	2 $\frac{5}{8}$
20	6016HR-20	1003R	6	141A	328C-20	5 $\frac{3}{4}$	10 $\frac{3}{4}$	2 $\frac{5}{8}$
24	6016HR-24	1003R	6	141A	328C-24	5 $\frac{3}{4}$	10 $\frac{3}{4}$	2 $\frac{5}{8}$

Side Hanger Hand Set Type:



No. 6116CH-12

No. of Buttons	Code No.	Hand Set and Switch-Hook	Includes Hand Set and Switch-Hook Box	Includes Key Box	Dimensions—Inches		
					Width	Length	Depth
6	6139C-6	1139C	328C-6	5	7 $\frac{1}{2}$	2 $\frac{5}{8}$	
12	6139C-12	1139C	328C-12	5	7 $\frac{1}{2}$	2 $\frac{5}{8}$	
16	6139C-16	1139C	328C-16	5 $\frac{3}{4}$	10 $\frac{3}{4}$	2 $\frac{5}{8}$	
20	6139C-20	1139C	328C-20	5 $\frac{3}{4}$	10 $\frac{3}{4}$	2 $\frac{5}{8}$	
24	6139C-24	1139C	328C-24	5 $\frac{3}{4}$	10 $\frac{3}{4}$	2 $\frac{5}{8}$	

Note: For further information on Inter-phones, write to nearest Graybar house.

TELEPHONES—CENTRAL BATTERY**TELEPHONES FOR USE WITH WESTERN ELECTRIC NO. 1801 SWITCHBOARD SYSTEMS****Systems A and B**

The telephones for the No. 1801 Switchboard Systems A and B are of the series talking circuit type and equipped with 140 ohm vibrating bells or buzzers (in accordance with the type of set selected), which operate on direct current.

Code No.	Mounting	—Dimensions of Housing—				
		High	Wide	Deep		
2527A	Surface Wall	7½"	5"	2⅝"		
2539A	Flush Wall	—Flush Plate—		—Outlet Box—		
		High	Wide	High	Wide	Deep
		9"	5⅓"	7½"	4"	2⅝"
	Hand Set		Apparatus Box		Connection Block	
6043R	1003AC		383H			
6139A	1139A		—		2 No. 11-A	
6145A	1145A		—		2 No. 11-A	

System C

The telephones for No. 1801 Switchboard System C may be of the same types as used for Systems A and B, but in case the system is connected to an outside exchange, telephones equipped with standard central battery induction coil talking circuit should be used in order to obtain satisfactory transmission.

System D

Any standard central battery telephone with ringers operated by alternating current either induction coil or series types can be used with System D.



No. 2527A



No. 2539A



No. 6043R



No. 6044A



No. 6038A

CABLE

Cable for use in Inter-Phone Installations is shown under Western Electric Cable.

NO. 19 TYPE CABLE TERMINALS

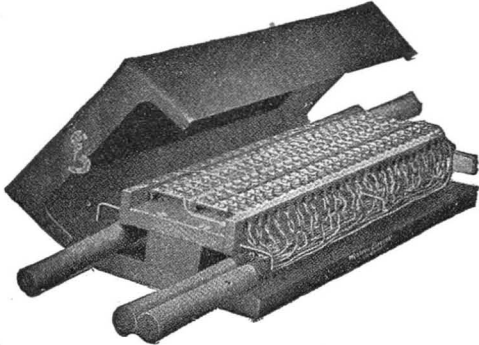

No. 19B, Cable Terminal

The No. 19 Type Cable Terminal is admirably suited for interior or distributing work. It was designed after a great deal of study, and is the best of its kind on the market. Made of hard wood, numbered and shellacked, and equipped with a sheet steel cover, treated with the Parker Rustproof Process, finished in Black Enamel.

Code No.	Capacity in Pairs	Length Ins.	Width Ins.	Depth Ins.
19A	14	8	5 1/8	2 1/2
19B	26	14	5 1/8	2 1/2

Telephone Auxiliary Signaling Relay Sets

TELEPHONE RINGING OF AUXILIARY SIGNALS AUDIBLE AND VISIBLE

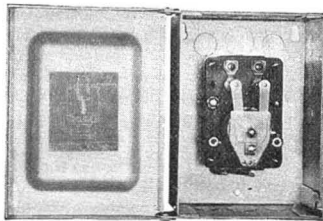

Type RS-2

Set Consists of Relay and Condenser.
Contacts*—Non-Inductive Rating, Double Break. 110 Volts—A.C., 10 Amps.; D.C., 3 Amps.

Operating Characteristics:
 Operates on 8 Milli-Amps. with 1 MF Condenser in Series with Coil of Relay. Impedance, 9,500 Ohms at 90 Volts, 20 Cy.

Mounting—Vertical, Enclosed in H-3 Housing. Baked Aluminum Finish.

Note—Also supplied for D.C. telephone ringing service. (Specify Voltage.)

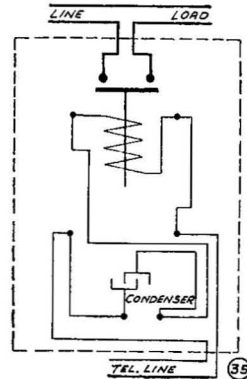

TELEPHONE RINGING OF AUXILIARY SIGNALS; POLICE, TAXICAB, ETC.

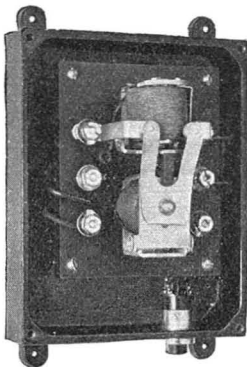

Type RS-3A

Set is complete with Relay, Condenser and Resetting Push Button. Mounted in Weatherproof Cast-Aluminum Housing.

Contacts*—Non-Inductive Rating, Double Break. 110 Volts—A.C., 10 Amps.; D.C., 5 Amps.

Operating Characteristics:
 Operates on 10 Milli-Amps. with 1 MF Condenser in Series with Coil of Relay. Impedance, 7,500 Ohms at 90 Volts, 20 Cy.

Relay is mechanical lock-in type. Lamp signal remains on till Relay is released through push button switch which is mounted in bottom of housing.

Mounting — Vertical, Enclosed in W-6 Weatherproof Housing.

Note—Also supplied for D.C. telephone ringing service. (Specify Voltage.)

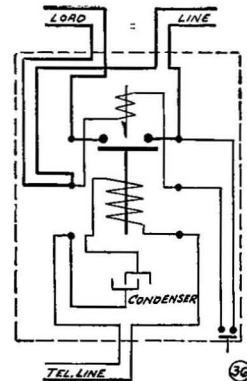

Nos. 50 and 150 Type Coin Collectors



50G



50K



150GJ

The "G" type coin collector is a prepayment, multi-coin collector arranged for wall mounting. It may, however, be mounted in a corner by means of a corner bracket or on a shelf by means of a backboard. The upper housing, coin box and backplate are of heavy pressed steel and the cash compartment door is of hardened pressed steel to prevent burglary. A burglar alarm switch which is operated by the cash compartment lock may be arranged to operate an alarm bell or buzzer adjacent to the coin collector. The cash compartment lock is a combination of pin tumbler and flat lever construction giving double security. This lock is coded No. 10-L. The collector is finished in black except the coin gauge and the coin return escutcheon which are chromium plated.

Three different coins may be used in this type of coin collector, nickels, dimes and quarters. As each coin is put in the slot a distinctive gong signal is given which is audible to the operator. The coins are held in the coin hopper and may be deposited or refunded at will. This feature makes it possible to use the prepayment plan thus saving the time lost by the operator in waiting for the coin to be deposited before completing the connection as is necessary when the post-payment plan is used. Overall dimensions: length, 18¼ inches; width, 7 inches; depth, 6 inches.

The No. 50-G coin collector is intended for manual service or machine switching service in conjunction with a desk set box with a two winding induction coil. Connections are provided to change to a sidetone reduction circuit if desired.

The No. 50-H coin collector differs from the No. 50-G only in the quarter coin channel which is adapted to receive both United States and Canadian quarters.

The No. 50-K coin collector is designed for use as a post-payment multi-coin collector, but is so arranged as to permit conversion into a prepayment coin collector. Except for this feature it is the same as the No. 50-G.

The Nos. 150-G, 150-H and 150-K coin collectors differ from the corresponding models above only in the circuit which is anti-side tone and requires the use of a desk set box with a three winding induction coil.

The Nos. 150-GJ, 150-HJ and 150-KJ coin collectors have a coin signal transmitter mounted within the case and a circuit arranged for the use of a handset.

Method of Ordering

For Manual Service

Nos. 50-G, 50-H, 150-G or 150-H Coin Collectors equipped with:

- No. 10-L lock.
- No. 50-C apparatus blank.
- No. 2-A coin receptacle (non-locking) or
- No. 6001-B coin receptacle (self-locking).
- No. 323 transmitter.
- No. 144 receiver.
- No. 521 receiver cord.

For Machine Switching Service

Nos. 50-G, 50-H, 150-G or 150-H Coin Collectors equipped with:

- No. 10-L lock.
- No. 1-B card holder.
- No. 2-A coin receptacle (non-locking) or
- No. 6001-B coin receptacle (self-locking).
- No. 323 transmitter.
- No. 144 receiver.
- No. 521 receiver cord.
- No. 4-H type dial.
- No. D4M cord.

Method of Ordering Handset Models

For Manual Service

Nos. 150-GJ or 150-HJ Coin Collectors equipped with:

- No. 10-L lock.
- No. 50-C apparatus blank.
- No. 2-A coin receptacle (non-locking) or
- No. 6001-B coin receptacle (self-locking).
- No. E1B handset.
- No. LD72 signal transmitter.

For Machine Switching Service

Nos. 150-GJ or 150-HJ Coin Collectors equipped with:

- No. 10-L lock.
- No. 50-C apparatus blank.
- No. 2-A coin receptacle (non-locking) or
- No. 6001-B coin receptacle (self-locking).
- No. E1B handset.
- No. 4H type dial.
- No. D4M cord.
- No. LD72 signal transmitter.

COIN COLLECTORS



No. 7 Mounted on a Central Battery Telephone



No. 11 Mounted on a No. 1317 Wall Telephone



No. 14 Mounted with a No. 1020 Desk Stand

Gray Telephone Pay Stations and Mounting Devices

NON-ELECTRICAL—FOR LOCAL OR CENTRAL BATTERY SERVICE

The operation of these pay stations is accomplished without the aid of moving parts or electrical connections, the signals being produced by the coins striking gongs or chimes, the sound of which is transmitted to the central office operator through the transmitter of the telephone at which the pay station is located. In view of the simplicity and reliability of these pay stations, their maintenance cost is extremely low.

(These pay stations cannot be used for "pre-payment" service, as the coin is not under the control of the central office operator, as in the No. 7 and No. 150 Type Coin Collectors.)

Gray Code No.	Type of Telephone Used on	Coins Arranged for	Approximate Size
7	Wall Telephone	Nickels, Dimes and Quarters	9 x 4½ x 3
This will be drilled to take standard types of transmitter arms, as specified in the order.			
8A	Wall Telephone	Nickels	7 x 3¾ x 3¼
This pay station will not be provided with a mounting bracket unless specifically so ordered. See next item.			

BRACKET FOR NO. 8A PAY STATION

In ordering this bracket, specify the make and code number of the telephone on which the pay station is to be used in order that the proper form of bracket may be furnished.

11	Wall Telephone	Nickels, Dimes and Quarters	9 x 4½ x 3
----	----------------	-----------------------------	------------

A mounting plate is included with this pay station for mounting it at the side of a telephone, as shown in the cut.

13A	Desk Telephone	Nickels	9½ x 3½ x 3¼
-----	----------------	---------	--------------

This is equipped with two clamps of such size as to fit the stem of a standard desk telephone. In ordering, specify the type and make of desk telephone with which it is intended for use.

14	Desk Telephone	Nickels, Dimes and Quarters	11 x 4½ x 3½
----	----------------	-----------------------------	--------------

Fittings will be furnished with this pay station to permit of attachment to standard types of desk telephones. In ordering, specify the type and make of desk telephone with which it is intended for use.

20	Desk Telephone	Nickels, Dimes and Quarters	10¾ x 4¼ x 3¼
----	----------------	-----------------------------	---------------

This pay station will be equipped with fittings to permit of its being attached to a standard type of desk telephone. Fittings are arranged so that the unit thus formed may be fastened to a counter or telephone booth shelf. In ordering, specify the type and make of desk telephone with which it is intended for use.

The above code numbers cover pay station boxes only and do not include telephone instruments.

TELEPHONE BRACKETS AND BRACKET MOUNTINGS

Burns HI-LO Brackets

Burns HI-LO Brackets are adjustable in-and-out, up-and-down, and down-and-up. The arm is self-balancing and permits use of telephone from a standing or sitting position.

Number	*Length of Bracket Extended	Approximate Shipping Weight
H87	28 in.	6 lbs.
H127	32 in.	6½ lbs.
H147	38 in.	7 lbs.

* Measuring from center of mounting to mouthpiece.

“EZ” Telephone Brackets Type

The “EZ” Telephone Bracket permits of a deskstand being instantly adjusted to a height convenient to the user. In addition to this the arm is pivoted on its mounting and may therefore be rotated in a horizontal plane. (24-in. radius.)

An “EZ” Telephone Bracket consists of:

- 1 Arm.
- 1 Mounting as specified in the order.
- 1 Clamp as specified in the order.

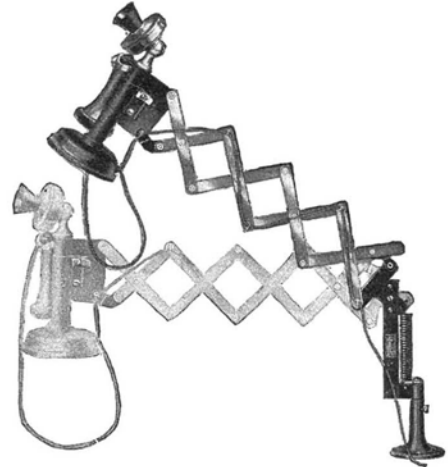

Mountings for Telephone Brackets

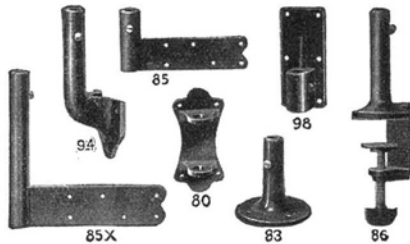

Mountings

- No. 80 for wall, post, window frame.
- No. 83 for top of flat top desk.
- No. 85, 85X for side of roll top desk.
- No. 86 for clamping to edge of desk.
- No. 94 for desk or for wall.
- No. 98 for window ledge, railing, etc.

Brackets complete with 80, 83, 85, 85X, 94 or 98 Mounting and any style clamp are standard complete equipment. Brackets equipped with No. 86 Mounting are furnished at extra charge. Standard finish is black enamel.

Clamps for Burns Telephone Brackets

CLAMPS

For holding desk stands of different designs the following types of clamps are provided:

“B” for any desk telephone with straight stem.



“G” for old style automatic stand with bulging stem.

“H” clamp for box telephone or for attaching to flat surface.

“C” clamp for W. E. Cradle Set.



TELEPHONE BRACKETS

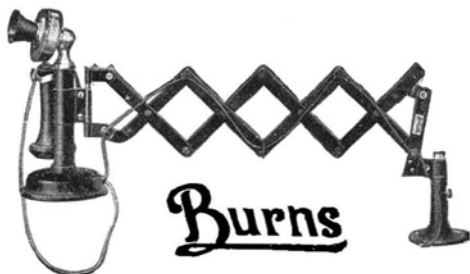

Regular

**Burns
Brackets**



No. 95 "EZ" Equipped with No. 83 Mounting and "B" Clamp

Regular Burns Brackets are adjustable in-and-out. The telephone swivels on the front rod, the bracket revolves on the base. Easily mounted on desk, wall or other convenient place.

Number	*Length of Bracket Extended	Approximate Shipping Weight	Number	*Length of Bracket Extended	Approximate Shipping Weight
87	26 in.	5 lbs.	147	38 in.	5¾ lbs.
107	30 in.	5¼ lbs.	167	42 in.	6 lbs.
127	34 in.	5½ lbs.			

* Measuring from center of mounting to mouthpiece.

Burns Dial Bracket

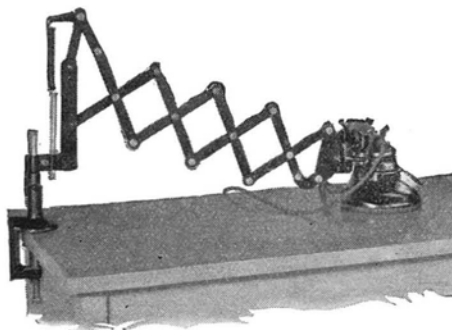
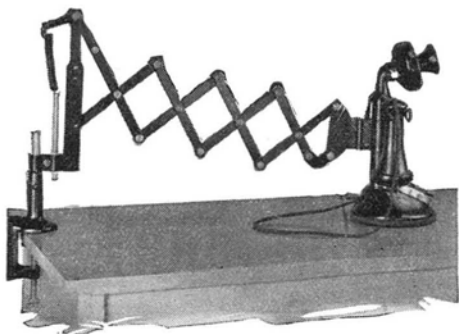

Especially designed for use with automatic telephone. Special hinged arm allows base to rest firmly on desk when dialing. Adjustable to different lengths. Furnished with any mounting or clamp desired. D-87 28" Burns Dial Bracket D-127 32" Burns Dial Bracket D-147 38" Burns Dial Bracket

DORMEYER Type "S" Telephone Extension Bracket

This bracket is of the "folding gate" type, and is arranged so as to revolve on its base. The desk stand swivels on the front rod. The bracket will be furnished with any of the mountings described below and with the No. 20 Clamp.



DORMEYER Type "S" Bracket equipped with No. 2 Mounting and No. 20 Clamp

When ordering specify the letter of the clamp and mounting that is wanted in addition to the list number of the telephone bracket.

List No.	Length of Bracket Extended, Ins.	Approximate Shipping Weight
8	26	5½ lbs.
10	30	6 lbs.
12	34	6¼ lbs.
14	38	6½ lbs.
16	42	7 lbs.

Complete equipment consists of bracket, one mounting, one receiver hook, one telephone clamp, one set of eyelets for holding cord, but does not include desk stand.

Mountings for DORMEYER Telephone Extension Brackets

- | | |
|----------|--|
| Code No. | Use |
| 1 | For use on side of flat or roll top desk. |
| 2 | For use on top of flat top desk. |
| 3 | Clamps on edge of flat top desk.* |
| 4 | For use on wall or partition. |
| 5 | For use on side of flat top desk.* |
| 6 | For use on side of flat or roll top desk, to be used with Universal Attachment.* |
| 7 | For use on side of flat top desk.* |
| 8 | Fastens to the wall. Especially adapted for use with Universal attachment. |
| 9 | Fits any mounting and holds two brackets. |
- * Not stocked. Furnished on order only.

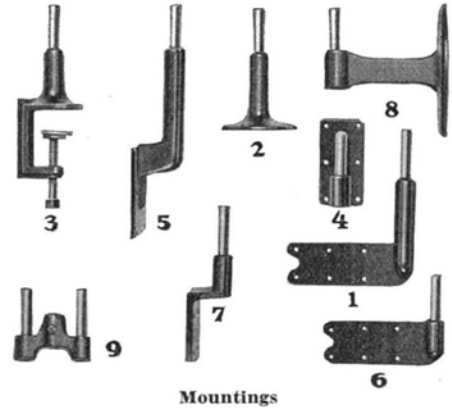

Clamps for DORMEYER Telephone Extension Brackets

- | | |
|----------|--|
| Code No. | Use |
| 20 | This clamp fits telephones with a cylindrical stem such as the <i>Western Electric</i> Nos. 1020 and 1040 Types. |
| 22 | This clamp fits the cradle type phone (such as Western Electric Hand Telephone Sets) |



Universal Attachment

Universal Attachment

The Universal Attachment fits any standard Arm. Inserted between extension arm and mounting, the Universal attachment permits freedom of movement up or down, in or out, as well as horizontal motion, thus permitting the phone to be used from standing or sitting position. It does not sag under the weight of the phone.

CHAIRS



Operator's Chair

Telephone switchboard operators' chairs are furnished in oak and also birch with mahogany finish. Seats are provided of closely woven cane or of leather over closely woven cane.

The heights given below indicate the distance of the seat from the floor when it is in the lowest position.

When ordering specify chair height, finish, and type of seat desired.

Height Ins.	Height Adjustment Ins.		Height Ins.	Height Adjustment Ins.
18	4		24	7
20	4		28	7

RINGING MACHINES

TELERING

The "Telering" is a frequency changer or impulse selector producing 20 cycle ringing current from 60 cycle 110 volt lighting current. Telering is recommended on P.B.X. Switchboards and on central office switchboards with not over two operators' positions.

The apparatus is composed mainly of a vibrating reed with an adjustable contact, a coil, a transformer and resistance lamps. The only moving part is the reed, which, due to its form, light weight and great flexibility, has an extremely long operating life.

The current consumption is less than 5 watts and the maximum current on any load cannot exceed the rating of the compensating lamps embodied in the machine. The machine, as a whole, is very compact, being 12" x 9" x 5", requiring little space for installations.

Telering will not disturb radio reception due to radiation.



RINGING MACHINES—Continued

**Magneto
Motor Generator
Ringing Sets**

Motor generator ringing sets consist of direct current, or single phase 60 cycle alternating current motors, connected direct to magneto ringing generators. These sets furnish alternating ringing current only at 80 volts, 19 cycles. An attachment for obtaining positive and negative pulsating current is, however, available. These direct connected motor generator sets form a very compact, serviceable unit.

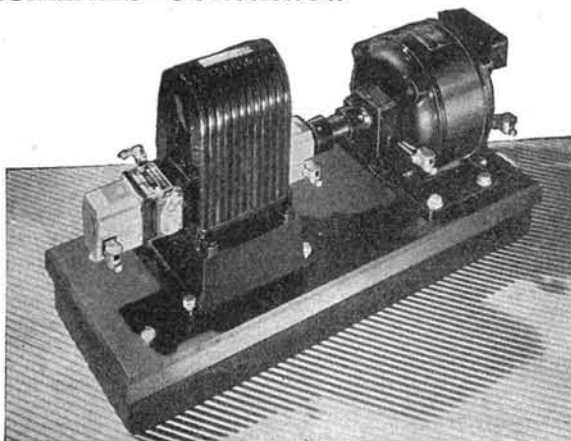

Motor Generator Ringing Set

List No.	Volts Motor	Output Watts	Type
310087W	110	15	} Motor—Single phase 60 cycles A.C., 1150 R.P.M. } Generator—80 volts, 19 cycles, single phase.
310088W	220	15	
310093W	110	15	} Motor—Single phase, 25 cycles, A.C., 1400 R.P.M. } *Generator—110 volts, 23 cycles, single phase.
310094W	220	15	
310081W	115	15	} Motor—D.C., 1150 R.P.M. } Generator—80 volts, 19 cycles, single phase.
310082W	230	15	
List No.	No. Bars	Output Watts	Type
310110W	12	15	Magneto Generator—80 volts, 19 cycles, single phase, 1150 R.P.M. Belt tightening sub-base and 2" x 2" Crowned pulley.

* This higher voltage is advisable on account of the higher frequency produced by the necessary excess speed of the 25-cycle over the 60-cycle.

Frequency Converters

Frequency converters operate directly from 110 volt, 60 cycle power current and supply 20 cycle straight line ringing current only, or 20 cycle straight line and positive and negative pulsating ringing current.

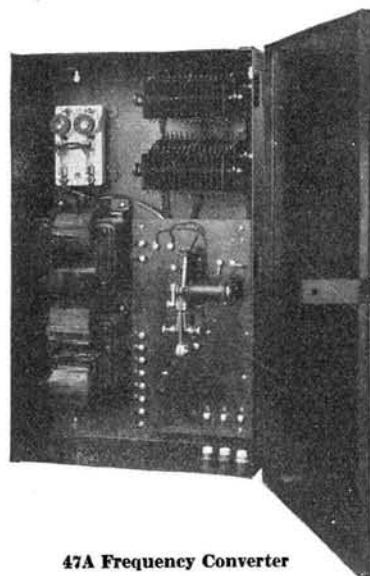

47A Frequency Converter

All apparatus is assembled in a black enameled steel cabinet measuring overall 24½" x 15" x 6½". Ringing vibrators and terminals are mounted as near to the front as possible for ease of inspection and adjustment of contacts. Noiseless dry plate rectifiers are used which eliminate the objectionable hum of the mechanical vibrating type. Only three current carrying contacts are used. These contacts require very little attention and have long life.

The operation is as follows: a transformer steps the voltage down to supply current to the dry plate rectifiers which separate the alternating current into two pulsating currents of equal value. These two pulsating currents are interrupted through the contacts of the ringing vibrator and the primary windings of the ringing transformer to produce an electric current in the transformer secondary windings, which is used for exchange ringing purposes.

Frequency converters are free from interference with radio receiving sets in common use at this time.

Converters of this type are the most economical ringing machines on the market and are recommended if continuous power current is available, for any telephone exchange operating 2000 telephones or less.

List No. 47A Frequency Converter (replaces Nos. 7A and 107A Types), supplies 20 cycle A.C. ringing current at approximately 80 to 100 volts. No load watt input is not over 8 watts; full load watt output is 12 watts at 80 volts.

List No. 48A Frequency Converter (replaces Nos. 8A and 108A Types), supplies 20 cycle A.C. ringing current at approximately 80 to 100 volts and positive and negative pulsating ringing current at approximately 45 to 60 volts.

RINGING MACHINES—Continued

Combined Charging and Ringing Machines

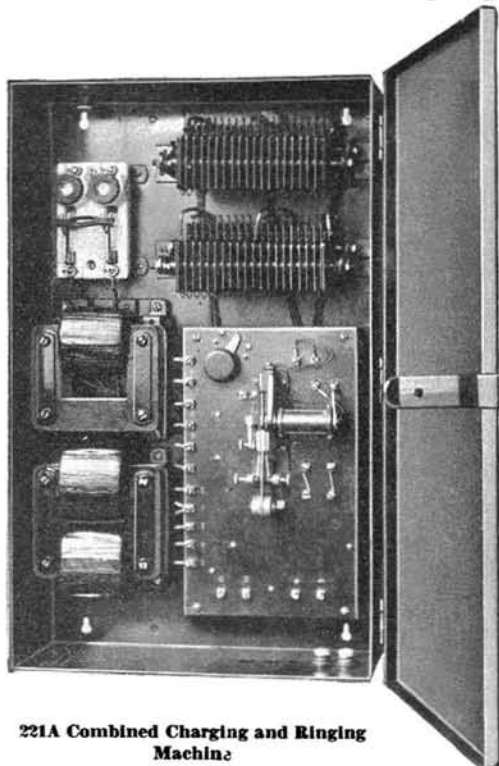

221A Combined Charging and Ringing Machine

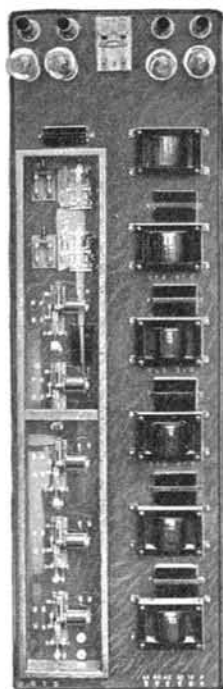

No. 227 Harmonic Ringing Machine

The combined charging and ringing machines work in conjunction with a storage battery so that current for operators' transmitters can be supplied from the same battery. Machines of this type are desirable in exchanges supplied with intermittent power current. They operate from 110 volt, 60 cycle power current and supply 20 cycle straight line ringing current only, or 20 cycle straight line and positive and negative pulsating ringing current. The ringing current is furnished by a storage battery (a 24 volt set furnished by the customer) that is charged by the machine. This combination is a reliable power plant furnishing steady ringing current unaffected by power voltage or interruption.

All apparatus is housed in a black fire-proof cabinet as illustrated. Overall dimensions $24\frac{1}{2}'' \times 15'' \times 6\frac{1}{2}''$. A popular and internationally known type of rectifier is used to charge the storage battery. A variable switch is wired in the charging circuit which allows either a 1, $1\frac{1}{2}$ or a 2 ampere rate to be delivered to the batteries.

The operation is as follows: a transformer steps the voltage down to supply current to the dry plate rectifiers which deliver the charge to the 24 volt storage battery. The current from the battery is interrupted through the contacts of the ringing vibrator and the primary winding of the ringing transformer to produce an electric current in the transformer secondary winding which is used for exchange ringing purposes.

Current from the 24 volt storage battery used with the combined charging and ringing machine can also be used on operators' transmitter sets. To accomplish this, it is necessary to use common battery operators' transmitters and wire an inexpensive auxiliary set (one required for each operator's position) in the switchboard transmitter circuit.

This is an efficient ringing machine and recommended for any telephone exchange operating 1500 or less telephones. Combined charging and ringing machines do not cause interference with radio receiving sets in common use at this time.

List No. 221A Combined Charging and Ringing Machine (replaces Nos. 15A, 21A, 21AR and 121AR), supplies 20 cycle A.C. ringing current. No load output 100 volts; full load watt output is 15 watts at 65 volts.

List No. 222A Combined Charging and Ringing Machine (replaces Nos. 16A, 16AR, 22A, 22AR, and 122AR), supplies 20 cycle A.C. ringing current and positive and negative pulsating ringing current.

List No. 2A Operator's Auxiliary Set—For use in supplying battery current for operators' transmitters.

Harmonic Ringing Machines

Harmonic Ringing Machines operate from 110 volt, 60 cycle power current and furnish standard voltage harmonic ringing current at the frequencies listed below. All apparatus is mounted on an oak backboard and the vibrators and rectifiers are housed under a glass case which is hinged to the backboard so as to swing clear for ease of inspection and adjustment. This machine is equipped with charging apparatus for maintaining a 24 volt storage battery (furnished by the customer), which is used as the source of power for the harmonic ringing current. The charging equipment consists of two mechanical vibrating rectifiers and resistance control. The rectifiers may be used singly or together. The charging rate of each is 1.3 amperes at 24 volts. Each rectifier automatically cuts off battery during power interruptions. Battery current is used to operate tuned reed vibrators to produce ringing current at harmonic frequencies required for a selective ringing system.

List No.	Power Voltage and Frequency	Ringling Frequencies
226	110 60 cycles	30-42-54-66 cycles
227	110 "	$16\frac{2}{3}$, $33\frac{1}{3}$, 50, $66\frac{2}{3}$
228	110 "	16, 30, 42, 54 and 66 cycles

WOOD POLE SPECIFICATIONS

Values for the ultimate fibre stresses of wood poles were approved by the American Standards Association November, 1930. These values are as follows:

Southern Yellow Pine Creosoted.....	7,400 lbs. per sq. in.
Western Red Cedar.....	5,600 lbs. per sq. in.
Northern White Cedar.....	3,600 lbs. per sq. in.
Chestnut.....	6,000 lbs. per sq. in.

This Association adopted the principles given below as a working plan for the development of the specification circumference table in which table Classes 1 to 7 are defined primarily by their circumferences at 6 ft. from the butt and designed to meet the following breaking loads under the conditions imposed in Principle 4. Classes 8, 9 and 10, having no butt requirement, were defined by minimum permitted top circumferences only.

Class	1	2	3	4	5	6	7
Lb. Sq. In.	4500	3700	3000	2400	1900	1500	1200

These principles are:

- 1.—All tables shall be based on standard fibre strengths, for the respective species.
- 2.—The tables shall specify dimensions in terms of circumference in inches at six feet from the butt, except for classes of "No Butt Requirement," and circumference in inches at the top for poles of the respective lengths and classes.
- 3.—All poles of the same length and class shall have when new approximately equal strength, or in more precise terms, equal moments of resistance at the ground line.
- 4.—All poles of different lengths within the same class shall be of suitable size to withstand approximately the same breaking load, assuming that the load is applied two feet from the top and that the break would occur at the ground line.
- 5.—The smallest class for which butt measurements shall be specified shall have a breaking load under the conditions stated in Principle 4 of approximately 1200 pounds.
- 6.—The largest class for which butt measurements shall be specified shall have a breaking load under the conditions stated in Principle 4 of approximately 4500 pounds.
- 7.—The classes from the lowest to the highest shall be arranged in geometric progression, the increments between classes, measured in terms of breaking load, to the approximately 25 per cent.

ASA Specification dimension tables will be found in this catalogue under each species of timber we discuss.

The breaking loads of the various classes previously mentioned are translated into terms of moments of resistance at the ground line and the required ground line circumferences were calculated by using beam formula $Mr = 0.00264fc^3$.

Mr is moment of resistance
 f is the standard fibre stress
 c is circumference in inches

In all classes and lengths the 6-foot circumference is usually larger than the minimums given in the table. Stating this in another way, the average 6-foot circumference for all lengths in any class is greater than one-half the difference between the class and the minimum of the next higher class. In general, too, the average pole of a given class will be considerably stronger than the rating for the class.

The basic principles upon which ASA Specification tables have been worked out conform to and are consistent with the accepted engineering practice of the larger transmission and communication utilities.

While these simplifications and standardizations on a national scale are of great interest to our customers, we still retain a belief that they cannot replace our individual specialization of method, developed over twenty-five and more years in this particular field.

A.S.A. Circumference Tables

WESTERN RED CEDAR POLES

Minimum Circumference at 6 Feet from Butt, Inches

Length of Pole Ft.	Ground Line Dist. from Butt Ft.	Class									
		1	2	3	Minimum Top Circumference, Inches		6	7	8	9	10
		27	25	23	21	19	17	15	18	15	12
16	3½	23.0	21.5	19.5	*	*	*
18	3½	28.5	26.5	24.5	22.5	21.0	*	*	*
20	4	34.5	32.0	30.0	28.0	25.5	23.5	22.0	*	*	*
22	4	36.0	33.5	31.5	29.0	27.0	25.0	23.0	*	*	*
25	5	38.0	35.5	33.0	30.5	28.5	26.0	24.5	*	*	*
30	5½	41.0	38.5	35.5	33.0	30.5	28.5	26.5	*	*	..
35	6	43.5	41.0	38.0	35.5	32.5	30.5	28.0	*
40	6	46.0	43.5	40.5	37.5	34.5	32.0
45	6½	48.5	45.5	42.5	39.5	36.5
50	7	50.5	47.5	44.5	41.0	38.0
55	7½	52.5	49.5	46.0	42.5	39.5
60	8	54.5	51.0	47.5	44.0
65	8½	56.0	52.5	49.0	45.5
70	9	57.5	54.0	50.5	47.0
75	9½	59.5	55.5	52.0	48.5
80	10	61.0	57.0	53.5	49.5
85	10½	62.5	58.5	54.5
90	11	63.5	60.0	56.0

* No butt requirement.

A.S.A. Circumference Tables—Continued

CREOSOTED SOUTHERN YELLOW PINE POLES

Length of Pole Ft.	Ground Line Dist. from Butt Ft.	Minimum Circumference at 6 Feet from Butt, Inches									
		Class									
		1	2	3	4	5	6	7	8	9	10
		27	25	23	21	19	17	15	18	15	12
16	3½	21.5	19.5	18.0	*	*	*
18	3½	26.5	24.5	22.5	21.0	19.0	*	*	*
20	4	31.5	29.5	27.5	25.5	23.5	22.0	20.0	*	*	*
22	4	33.0	31.0	29.0	26.5	24.5	23.0	21.0	*	*	*
25	5	34.5	32.5	30.0	28.0	26.0	24.0	22.0	*	*	*
30	5½	37.5	35.0	32.5	30.0	28.0	26.0	24.0	*	*	..
35	6	40.0	37.5	35.0	32.0	30.0	27.5	25.5	*
40	6	42.0	39.5	37.0	34.0	31.5	29.0	27.0
45	6½	44.0	41.5	38.5	36.0	33.0	30.5	28.5
50	7	46.0	43.0	40.0	37.5	34.5	32.0	29.5
55	7½	47.5	44.5	41.5	39.0	36.0	33.5
60	8	49.5	46.0	43.0	40.0	37.0	34.5
65	8½	51.0	47.5	44.5	41.5	38.5
70	9	52.5	49.0	46.0	42.5	39.5
75	9½	54.0	50.5	47.0	44.0
80	10	55.0	51.5	48.5	45.0
85	10½	56.5	53.0	49.5
90	11	57.5	54.0	50.5

NORTHERN WHITE CEDAR POLES

16	3½	26.0	24.0	22.0	*	*	*
18	3½	32.5	30.0	28.0	25.5	23.5	*	*	*
20	4	39.5	37.0	34.0	31.5	29.0	27.0	25.0	*	*	*
22	4	41.0	38.5	36.0	33.0	30.5	28.0	26.0	*	*	*
25	5	43.5	41.0	38.0	35.5	32.5	30.0	28.0	*	*	*
30	5½	47.5	44.5	41.5	38.5	35.5	33.0	30.5	*	*	..
35	6	50.5	47.5	44.0	41.0	38.0	35.0	32.5	*
40	6	53.5	50.0	46.5	43.5	40.0	37.0
45	6½	56.0	52.5	49.0	45.5	42.0
50	7	58.5	55.0	51.5	47.5	44.4
55	7½	61.0	57.5	53.5	49.5	46.0
60	8	63.5	59.5	55.5	51.5

Table of Shipping Weights for Northern White Cedar Poles

NORTHERN WHITE CEDAR ASSOCIATION

Specification Size

Top In.	Length Ft.	Wt. Lbs.	Top Ins.	Length Ft.	Wt. Lbs.	Top In.	Length Ft.	Wt. Lbs.	Top In.	Length Ft.	Wt. Lbs.
4	16	85	6	30	350	5½	20	130	8	40	1100
5	16	105	6½	30	350	6	20	190	6	45	900
6	16	135	7	30	450	7	20	250	7	45	1100
7	16	165	8	30	600	8	20	350	8	45	1350
8	16	200	5	35	375	4	25	150	6	50	1150
4	18	95	5½	35	375	5	25	200	7	50	1350
5	18	125	6	35	450	5½	25	200	8	50	1700
6	18	155	6½	35	450	6	25	250	6	55	1300
7	18	200	7	35	600	6½	25	250	7	55	1700
8	18	325	8	35	850	7	25	350	8	55	2200
4	20	100	6	40	625	8	25	450	7	60	2200
4½	20	100	6½	40	625	5	30	275	8	60	2500
5	20	130	7	40	850	5½	30	275

MINIMUM WEIGHT REQUIRED FOR CARLOADS

Single Cars..... 30000 Lbs. Double Loads (Poles Requiring 2 Cars) 60000 Lbs.

International CREOSOTED PINE POLES
Specification for the Preservative Treatment
of Southern Yellow Pine Poles
Seasoning—Continued

INITIAL AIR PRESSURE

In the case of air-seasoned poles, Initial Air Pressure is the first step in the treating process. With steam-seasoned poles this step immediately follows the Initial Vacuum.

The poles shall be subjected to air pressure of sufficient intensity and duration (usually 40 lbs. to 70 lbs.) to provide under a quick high vacuum the ejection of surplus preservative, and to insure a retention and proper distribution of the stipulated number of pounds of preservative per cubic foot of wood.

TREATMENT

The creosote shall be introduced between 170° F. and 210° F., the cylinder pressure being maintained constant until the cylinder is filled. The oil must be seen by the inspector to flow from the overhead drum on top of the treating cylinder, thus assuring him that the cylinder is completely filled with the preservative. The pressure shall then be gradually raised to and maintained at a minimum of 150 lbs. per square inch until there is obtained the largest gross absorption that can be reduced to the stipulated final retention, calculation being based on readings of the working tank gauges and the weight of the creosote at 100° F. The quantity of oil for final retention shall be based on the cubic content of wood in the treating cylinder as determined by actual measurement of the top and butt of each pole in each charge. Under no conditions may shortage of oil in one charge be offset by overage in another; the minimum final retention in each case must be 100 per cent of the quantity of creosote specified.

FINAL VACUUM

After pressure is completed and the cylinder is emptied of oil a sufficient vacuum shall be promptly created and maintained until the timber can be removed from the cylinder free from dripping oil.

PRESERVATIVE

For preservative see Creosote Specification.

Note: A final retention of 8, 10 or 12 pounds of creosote per cubic foot are most frequently used. Of these, the 8-pound treatment is specified in the great majority of cases.

Standard Specifications for Cresote Oil
American Wood Preservers Association

GRADE 1

1.—The oil shall be a distillate of coal-gas tar or coke-oven tar.* It shall comply with the following requirements:

2.—It shall not contain more than three per cent of water.

3.—It shall not contain more than 0.5 per cent of matter insoluble in benzol.†

4.—The specific gravity of the oil at 38° C., compared with water at 15.5° C., shall be not less than 1.03.

5.—The distillate, based on water-free oil, shall be within the following limits:

Up to 210° C., not more than 5 per cent.

Up to 235° C., not more than 25 per cent.

6.—The residue above 355° C., if it exceeds 5 per cent, shall have a float test of not more than 50 seconds at 70° C.

7.—The oil shall yield not more than 2 per cent of coke residue.

8.—The foregoing tests shall be made in accordance with the standard methods of the American Wood-Preservers' Association. (See Manual—Creosote, Analysis.)

* Owing to the complexity of the chemical composition and physical properties of coal-tar creosote oil, and to the fact that some of the same compounds and properties which characterize coal-tar creosote are found in certain petroleum derivatives, the determination of the purity of creosote oil is difficult. When there is not certain assurance that the oil is a pure product, the following tests will aid in arriving at an opinion as to its coal-tar origin.

A.—Fraction distilling between 210° and 235° C. is usually solid or contains some solids when cooled to 25° C.

B.—All of the fractions up to 315° C. contain tar acids in varying amounts, usually at least 1 per cent calculated on the amount of the fraction tested. (See Manual—Creosote, Analysis, Tar Acids.)

C.—The specific gravity of the fraction between 235° and 315° C. is usually not lower than 1.025 and specific gravity of the fraction between 315° and 355° C. is usually not lower than 1.085 at 38° C. compared with water at 15.5° C. However, some pure coal-tar distillates fall slightly below these limits.

If the oil does not comply with at least one of the foregoing tests it is undoubtedly not a pure coal-tar creosote.

† Samples of oil taken from working tanks may show an increase in matter insoluble in benzol due to treating operations. Such increases provided they do not exceed by 1 per cent the specification limits should not serve to cause rejection of the oil for non-conformity with specifications if it can be shown that the original fresh oil was of specified quality.

WOOD CROSSARMS—Continued**Rainier Wood Crossarms**

The prime requisites in a crossarm are lightness, strength and durability. Some engineers stress one quality and some another, but Rainier Fir is the best answer for all sorts of uses and conditions. However, we are equally able to furnish long leaf yellow pine crossarms, and creosoted arms, in either fir or yellow pine.

Rainier fir crossarms do not require painting or the use of any preservative; are more than double the necessary strength with a large "factor of safety"; they live in actual service for many years.

**MINIMUM CARLOAD WEIGHT**

Fir from Pacific Coast Mills, 38,000 pounds. Small cars are scarce and weight of at least 50,000 pounds should be figured on. Cars to contain as high as 90,000 pounds can be had. Smaller cars are available in the Southern Yellow Pine Regions—minimum weight, 34,000 pounds.

All dimensions are subject to the usual manufacturing variations; crossarms long in stock show some shrinkage from original dimensions.

RAINIER WOOD CROSSARMS

Cat. No.	Size and Length	Pin Holes			Center Size In.	Bolt Hole In.	Brace In.	Weight Pounds per Arm			
		Spacings, In.		Center				Fir	Yellow Pine Untreated	Yellow Pine Creosoted	
		Center	Sides	Ends					8 Lbs.	12 Lbs.	
R. S. A. (Railway Signal Association) Arms, 3 x 4¼ In.											
21	6 ft. 4 pin	20	22	4	¾	1¼	..	19.8	24.6	28.44	29.70
22	8 ft. 6 pin	19	17¼	4	¾	1¼	..	26.4	32.8	37.92	39.60
23	10 ft. 8 pin	19	15½	4	¾	1¼	..	33	41	47.40	49.50
24	10 ft. 10 pin	16	12¾	2½	¾	1¼	..	33	41	47.40	49.50
Western Union Arms, 3 x 4¼ In.											
25	6 ft. 6 pin	20	11½	3	¾	2¼	..	19.8	24.6	28.44	29.70
26	8 ft. 8 pin	21	11½	3	¾	2¼	..	26.4	32.8	37.92	39.60
27	10 ft. 10 pin	22	11½	3	¾	2¼	..	33	41	47.40	49.50
Pony Telephone Arms, 2¾ x 3¾ In.											
31	24 in. 2 pin	17	3½	1¾	5/8	..	5.4	6.5	7.50	7.84
32	30 in. 2 pin	23	3½	1¾	5/8	..	6.75	8.125	9.38	9.80
33	36 in. 2 pin	29	3½	1¾	5/8	25	8.1	9.75	11.25	11.76
34	42 in. 4 pin	16	9½	3½	1¾	5/8	28	9.45	11.375	13.13	13.72
35	62 in. 6 pin	16	9¾	3½	1¾	5/8	28	13.95	16.8	19.38	20.25
36	82 in. 8 pin	16	9¾	3¾	1¾	5/8	28	18.45	22.2	25.63	26.79
37	102 in. 10 pin	16	9¾	4	1¾	5/8	28	22.95	27.625	31.88	33.72
38	120 in. 12 pin	16	9⅝	3⅞	1¾	5/8	28	27	32.5	37.50	39.20

Any change required from standard spacings, pin holes or bolt holes as here given, must be distinctly specified on the order.

WOOD PINS

Specifications

Material.—Pins shall be sound, reasonably straight grained, yellow or black locust (or Oak, as called for), free from knots, checks, sapwood, brash-wood, cracks, etc., except as hereinafter specified.

Sapwood.—Sapwood is permitted on the shoulder of the pin provided it does not extend into the tenon.

Checks.—Season checks not over 1/8 inch deep are permitted provided they do not appear elsewhere than in the shoulder and lower half of the tenon.

Knots.—Pins shall be free from loose or unsound knots; sound knots not exceeding 1/4 inch in diameter are permitted on the shoulder and lower half of the tenon.

Grain.—The grain of the wood shall be reasonably parallel to the axis of the pin; irregularities in grain which are wholly confined to the section within one inch of the bottom of the tenon shall be permitted.

Worm Holes.—Worm holes and channels not over 1/8 inch diameter are permitted provided they do not impair the holding power of the thread or the placing of the nail in the pin, and provided that they shall not appear in over 10 per cent of pins in any shipment.

Dimensions.—Pins are usually made from unseasoned wood due to difficulty of securing and manufacturing seasoned timber. Pins after seasoning shall be of the dimensions shown in drawing, or as ordered (with allowable variations as shown).

Flat Shoulders.—One flat surface is permitted, provided the wood is not cut away to the depth of the shoulder at any point of the circumference; in the bottom one-fourth of the tenon irregularities in shape which do not involve the removal of more than one-quarter of the cross-section called for in the drawing are permitted; provided these defects do not occur in more than 10 per cent of the pins furnished.

Threads.—All pins shall have four threads per inch; the threads shall be smooth and of uniform pitch; the thread shall taper 1/16 inch in diameter to 1 inch in length.

		1 1/4 x 8 Pins Inches	1 1/2 x 9 Pins Inches	Allowable Variation Inches
L =	Length Pin.....	8	9	1/4
F =	“ Top.....	4	5	1/4
E =	“ Tenon.....	4	4	1/4
D =	Diameter Thread.....	63/64	63/64	1/64
C =	Length “.....	2 1/2	2 1/2	1/4
S =	Diameter Shoulder.....	1 1/2	1 3/4	1/16
T =	“ Tenon on Top.....	1 3/32	1 11/32	1/64
M =	“ at Middle.....	1 1/4	1 1/2	1/32
B =	“ at Bottom.....	1 3/16	1 7/16	1/16

STANDARD PINS



Dimensions			Locust Wt. Lbs. per 1000	Oak Wt. Lbs. per 1000	Dimensions			Locust Wt. Lbs. per 1000	Oak Wt. Lbs. per 1000
M	L	D			M	L	D		
1 1/4	8	1	325	300	1 1/2	9	1	450	400

TRANSPOSITION PINS



1 1/4	9	1	400	350	1 1/2	10	1	500	450
-------	---	---	-----	-----	-------	----	---	-----	-----

HIGH TENSION PINS



1 1/2	9	1 3/8	450	400	1 3/4	12	1 3/8	1300	1100
1 1/2	11	1 3/8	550	500	1 3/4	10 1/8	1	1000	850
1 1/2	12	1	600	550	1 3/4	10 1/8	1 3/8	1100	900
1 1/2	12	1 3/8	650	600	1 3/4	14	1 3/8	1400	1200
1 3/4	12	1	1200	1000	

DUPLEX PINS



1 1/4	11 1/2	1	500	450	1 1/2	12	1	650	600
1 1/4	12	1	550	500	

WOOD BRACKETS, POLE STEPS AND COBS

Specifications

Material.—Sound, reasonably straight grained, Oak, free from knots, checks, sapwood, etc., except as hereinafter specified.

Sapwood.—Permitted up to 25 per cent of volume of bracket.

Checks.—Season checks not over 1/8 inch deep are permitted provided they do not appear within two inches of the thread.

Knots.—Brackets shall be free from loose or unsound knots; sound knots not exceeding 1/2 inch in diameter permitted below the shoulder, but not in lower 3-inch section of bracket.

Grain.—Grain of the wood shall be reasonably parallel to the axis of the bracket.

Worm Holes.—Any channels not over 1/8 inch diameter are permitted provided they do not impair the holding power of the thread, or the nail holes; and provided that they shall not appear in over 10 per cent of the brackets furnished in any shipment.

Dimensions.—After seasoning, dimensions with allowable variations shall be as shown; Wane allowed in body of bracket not exceeding 1/4 inch; irregularities in body of bracket not to exceed 10 per cent of volume.

Threads.—All brackets shall have four threads per inch; the thread shall be smooth and of uniform pitch; the thread shall taper 1/16 inch in diameter to 1 inch in length.

Manufacture.—All workmanship shall be of best commercial grade.

Standard Package.—Nos. 1, 3, 4 and 5, 25 per bundle. Nos. 2 and 6, 20 per bundle.

It is the practice to furnish oak pins and brackets "dipped in red paint," without extra charge; this treatment is of little or no protective value, and we earnestly recommend instead, a dipping in hot Creosote Oil, at a slight additional charge; not only does this make a clean bracket, but gives a preservative value, and a lasting effect.

L = Length Bracket	As ordered	Allowable Variation Inches 1/4
D = Diameter Thread	63/64	1/64
C = Length "	2 1/2	1/4
W = Width	As ordered	1/8
S = Height at Shoulder	" "	1/8

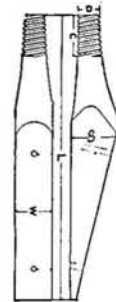

BRACKETS



	Dimensions				Wt. Lbs. per 1000
	W	S	L	D	
Standard No. 4.....	1 1/2	2	10	1	500
" " 1.....	1 1/2	2	12	1	650
" " 3.....	1 1/2	2 1/4	12	1	700
" " 5 A. T. & T.....	1 5/8	2	12	1	650
" " 2.....	2	2 1/4	12	1	850
" " 6 W.U.....	2	2 3/8	12	1	850
" " 7 W.U.....	2	2 3/4	12	1	950

POLE STEPS



Standard.....	1 1/2	2	7	..	450
Western Union.....	1 3/4	2 1/4	7	..	650

CONSTRUCTION MATERIAL

PEIRCE POLE SEATS

Hot Galvanized

The frames and braces of all styles are of 1 x 1/2-inch channel steel. The wood seats are 1 1/8-inch cypress, boiled in creosote. The bars of the all steel seats are 3/8-inch square steel, let into the frame in such manner as to leave no projecting ends. There is no strain on the riveted joints. The bars are placed with corners up to prevent slipping. They are shipped completely assembled in bundles of five.

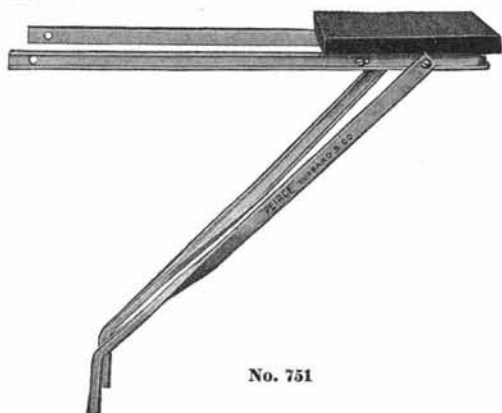

No. 751

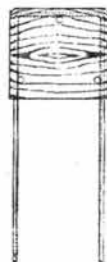

No. 751

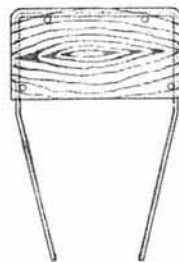

No. 753

Cat. No.	Size of Seat Inches	Style of Seat	Std. Pkg.	Wt. Lbs. per 100
751	11 x 12	Wood, Creosoted	5	1260
753	11 x 20	Wood, Creosoted	5	1400

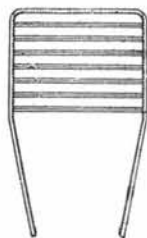

No. 755

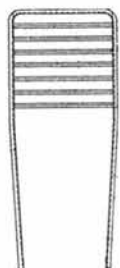

No. 757

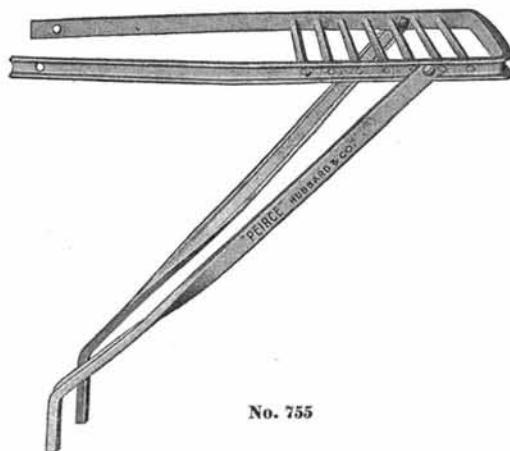

No. 755

Cat. No.	Size of Seat Inches	Style of Seat	Std. Pkg.	Wt. Lbs. per 100
755	12 x 13 7/8	Steel, Galvanized	5	1400
757	12 x 11	Steel, Galvanized	5	1260

HUBBARD CABLE SUSPENSION CLAMPS

Hot Galvanized

These are the standard A. T. & T. Company's Cable suspension clamps, the one-bolt type being used for light cables and on cable arms, and the three-bolt clamp for heavy cables and long spans. The one-bolt clamp is furnished without a bolt, as the 5/8-inch through bolt is used both for attaching the clamp to the pole and tightening the clamp on the stand. The three-bolt clamp is furnished with two 1/2-inch high carbon steel guy clamp bolts.



Cat. No.	Type	Length Inches	Size Strand Inches	Std. Pkg.	Wt. Lbs. per 100
8901	1-Bolt	2 3/8	1/4 to 3/16	250	74
8903	3-Bolt	5 5/8	1/4 to 3/16	100	220

CONSTRUCTION MATERIAL



HUBBARD STEPS FOR WOOD POLES
Hot Galvanized

Cat. No.	Dimensions, Inches		Std. Pkg.	Wt. Lbs. per 100
	Diameter	Length		
7123	3/16	9	300	70
7125	5/8	10	250	95
*7126	5/8	10	175	115

* Long hook head.

HUBBARD POLE STEPS FOR WOOD POLES
Button Head—Hot Galvanized



Cat. No.	Dimensions, Inches		Std. Pkg.	Wt. Lbs. per 100
	Diameter	Length		
7129	5/8	9 11/16	175	105

PEIRCE DETACHABLE POLE STEPS
Hot Galvanized



Lag Screw Type

Lag screw type is installed by slipping the plate over the lag and screwing lag in pole until the plate bites into the wood. Step slides down in a groove on each side of head of lag. When the step is removed nothing but the head of the lag extends from pole. Prevents mischievous ascents of pole and accidents.

Cat. No.	Description	Ext. from Pole, In.	Std. Pkg.	Wt. Lbs. per 100
7235	Lag and Plate	...	250	65
7236	Step	5 1/8	250	50

HUBBARD GUYEYE BOLTS
Hot Galvanized



5/8-Inch—1/2 x 3/4-Inch Oblong Eye

Cat. No.	Lgth. In.	Std. Pkg.	Ship. Wt. Lbs. per 100		Cat. No.	Lgth. In.	Std. Pkg.	Ship. Wt. Lbs. per 100
9060	10	50	140		9065	15	50	190
9062	12	50	160		9068	18	50	220

3/4-Inch—5/8 x 7/8-Inch Eye

Cat. No.	Lgth. In.	Std. Pkg.	Ship. Wt. Lbs. per 100		Cat. No.	Lgth. In.	Std. Pkg.	Ship. Wt. Lbs. per 100
9080	10	50	210		9085	15	25	300
9082	12	50	240		9088	18	25	340

CONSTRUCTION MATERIAL

HUBBARD DROP-FORGED WIRE ROPE CLIPS

Hot Galvanized

Designed so that the lay of the strand fits the body of the clip perfectly.

Drop-forged from best quality open hearth steel. With hot galvanized U-bolts and nuts. Legs of U-bolts are so spaced as to give greatest allowable clearance when tightening the nuts with a wrench.



Cat. No.	Size Strand Inches	Wt. Lbs. per 100	Cat. No.	Size Strand Inches	Wt. Lbs. per 100
7480	1/4	30	7485	5/8	100
7481	5/16	30	7486	3/4	150
7482	3/8	34	7487	7/8	245
7483	7/16	70	7488	1	260
7484	1/2	70			

HUBBARD POLE REINFORCING MATERIAL

Hot Galvanized



Reinforcement Band



Reinforcement Pipe

The Hubbard Reinforcement Band makes a strong and reliable method for attaching a stub when the butt of a pole is rotted. This arrangement saves the expense of installing a new pole and provides a reinforcement which adds years of life to the pole.

Bolts and lag screws to complete this construction should be ordered separately.

Cat. No.	Description	Size	Std. Pkg.	Wt. Lbs. per 100
7850	Reinforcement Band	12 Ga. x 2" x 68 1/2"	10	410
7851	Reinforcement Band	12 Ga. x 2" x 89 1/2"	10	525
7852	Reinforcement Pipe	2" Ex. Hvy. x 5"	10	220
7855	Reinforcement Band	10 Ga. x 2" x 99"	10	780
7856	Reinforcement Band	10 Ga. x 2" x 120"	10	1010

HUBBARD POLE MARKERS

Solid Copper and Aluminum Alloy

Stamped with raised letters or numerals as ordered. Consecutive numerals are depressed. Nominal die charge for quantities less than 1000 pieces, unless standard dies are used, and in all cases of special dies.



Cat. No.	Material	Over All Lgth. In.	Head In.	Shank In.	Std. Pkg.	Shp. Wt. Lbs. per 100
2000	Copper	2	1	5/16	1000	7
6000	Alum. Alloy	2	1	5/16	1000	3.2

HUBBARD POLE DATING NAILS

Hot Galvanized

Used for indicating the year in which poles were set and also the height of poles. Special nails with 2 or 3 numerals, letter or characters, depressed in the head can be furnished. Overall length, 2 1/2 inches.



Standard package, 100. Weight per 100, 4.4 pounds.

Cat. No.	1900	1920	1921	1922	1923	1924	1925	1926
No.	Blank	20	21	22	23	24	25	26
Cat. No.	1927	1928	1929	1930	1935	1940	1945	1955
No.	27	28	29	30	35	40	45	55

CONSTRUCTION MATERIAL**HUBBARD TELEPHONE CORNER BRACKETS**

Hot Galvanized



Used where the lead from the pole comes to the building at an angle. Mounting and insulator holes on Nos. 9204 and 9205 are $\frac{1}{32}$ inch. Mounting holes on Nos. 9206 and 9207 are $\frac{1}{32}$ inch, insulator mounting holes, $\frac{1}{32}$ inch.

Cat. No.	Size Steel Inches	Length Legs Inches	Std. Pkg.	Wt. Lbs. per 100
9204	$1\frac{7}{32} \times \frac{7}{32}$	$5\frac{5}{8} \times 2\frac{1}{2}$	250	60
9205	$1\frac{7}{32} \times \frac{7}{32}$	$10\frac{1}{8} \times 1\frac{5}{16}$	200	87
9206	$1\frac{1}{2} \times \frac{3}{16}$	$4\frac{3}{4} \times 2\frac{1}{2}$	250	60
9207	$1\frac{1}{2} \times \frac{1}{4}$	$4\frac{3}{4} \times 4\frac{1}{2}$	200	110



No. 9225

HUBBARD PORCELAIN KNOBS FOR TELEPHONE BRACKETS

These knobs are of dry process white glazed porcelain, and are for use with the telephone brackets listed above.



No. 9226

Cat. No.	Type	Dimensions, Inches		Ship. Wt. Lbs. per 100
		Diam. Bolt Hole	Height	
9225	Two-Groove	$\frac{3}{8}$	$1\frac{1}{2}$	20
9226	Four-Groove	$\frac{1}{2}$	$2\frac{1}{4}$	36

HUBBARD BOLTS FOR TELEPHONE BRACKETS

Hot Galvanized

For attaching porcelain knobs to telephone brackets.

Cat. No.	Type	Diam. Inches	Length Inches	Std. Pkg.	Wt. Lbs. per 100
9232	Stove Bolt	$\frac{5}{16}$	2	3000	6.0
9603	Machine Bolt	$\frac{3}{8}$	3	1500	12.6
9605 $\frac{1}{2}$	Machine Bolt	$\frac{3}{8}$	$5\frac{1}{2}$	750	19.8

HUBBARD TELEPHONE DISTRIBUTING BRACKETS

Hot Galvanized



No. 9202

Cat. No.	Style Bracket	Dimensions, Inches		Approx. Ship. Wt. Lbs. per 100
		Size of Steel	Length of Legs	
9202	L Pole	$2 \times \frac{1}{4}$	$3\frac{3}{4} \times 3$	87
9200	L House	$1\frac{3}{4} \times \frac{3}{16}$	$3\frac{1}{4} \times 2\frac{7}{8}$	51

HUBBARD TELEPHONE KNOB SCREW INSULATORS

Hot Galvanized

No. 2920 knob and screw. The screw is $\frac{3}{8}$ -inch in diameter and threaded for $1\frac{1}{2}$ inches.

No. 2927 knob is used with No. 2920 screw. It is made of brown glazed dry process porcelain and is $1\frac{1}{2}$ inches high and $1\frac{3}{4}$ inches in diameter. Wire groove is $\frac{1}{2}$ -inch wide. Hole, $\frac{1}{2}$ -inch in diameter, is well rounded on outer edges to prevent cutting insulating of wire.



Cat. No.	Per 100	Standard Package	Wt. Lbs. per 100
2920	\$13.60	500	48
2927	8.40	100	29

CONSTRUCTION MATERIAL
SPAULDING UNIVERSAL TREE WIRE GUARDS

These guards are made of 2 materials. For the inside of the tube a flexible bake-lized fabric is provided, of high dielectric strength, affording perfect electrical protection. This is an inert material which will not oxidize nor deteriorate after long-time exposure.

Several turns of the flexible insulating material enclose the wire. Overlying this inner protection is a tough outside shell of glass-hard finish. This shell is built up of strong, tough fabric, bonded with phenolic varnish for density and resistance to abrasion. Will not abrade or wear through.

Economical in that it is not necessary to cover the wire from one pole to another in order to protect a section of it. Also has the constant gripping action which maintains the tightness of the convolutions and prevents any longitudinal displacement.

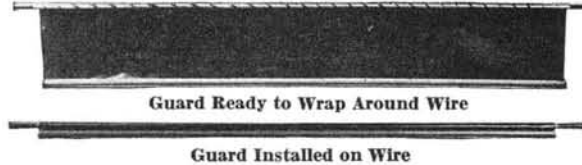

FOR INSULATION AND ABRASION

Type	Size Wire	Dimensions, Inches		
		Outside Shell	Flex. Sec.	Lgth.
For 2600 Volts				
A	{ No. 6 to No. 2 W. P. 3-Brd. No. 1 to No. 00 Str. Bare 30 to 40-Inch Diam. }	4½	6	38
For 5000 Volts				
B	{ No. 6 to No. 2 W. P. 3-Brd. No. 1 to No. 00 Str. Bare 30 to 40-Inch Diam. }	5	12	38
C	{ No. 8 W. P. 3-Brd. No. 8 to No. 2 Sol. Bare 16 to 26-Inch Diam. }	4	9	38
D	{ No. 1 to No. 0 W. P. 3-Brd. No. 000 to No. 250,000 cir. mil. Str. Bare .50 to .66-Inch Diam. }	7	17	38
E	{ No. 00 to No. 0000 W. P. 3-Brd. No. 250,000 to No. 500,000 cir. mil. Str. Bare .66 to .80-Inch Diam. }	9	22	38
For 7500 Volts				
K	{ No. 8 to No. 2 W. P. 3-Brd. No. 8 to No. 00 Sol. Bare .13 to .42-Inch Diam. }	7	22	38



FOR ABRASION ONLY

Provides approximately 2 wraps around the wire. Furnished in 1½, 2 and 10-foot lengths. In ordering, specify type and length required.

ACCESSORIES

Double faced adhesive tape is furnished with each order of tree wire guards to secure guard to wire for easiest installation. A set of installation directions is wrapped with each guard.

FIBRE INSTALLATION TOOL

A special tool of insulating fibre for installation of Spaulding Tree Wire Guards (Types A to K inclusive). The installation of these guards should not be attempted without the use of this tool.

With the use of this tool, these guards can be completely installed in 5 minutes or less, even in extremely cold weather.

For installing abrasion guards in 10-foot lengths, a special tool is made for opening the guard and applying it to the wire.

HUBBARD GUY WIRE PROTECTORS

Hot Galvanized

The protector illustrated is practically full-round and provides maximum visibility, safety and protection to the guy wire and the public. Complete drainage and ventilation give long life.

Simply and permanently installed with 2 bolts. Easy access to all guy fastenings at all times.

Nos. 7597-7598 protectors have many advantages over former styles 7557, 7558, 7559, included in the listing and which can still be furnished.

Cat. No.	Lgth. Ft.	Ship. Wt. Lbs. per 100
7557	7	1100
7558	8	1250
7559	8	1360
7597	7	1000
7598	8	1100

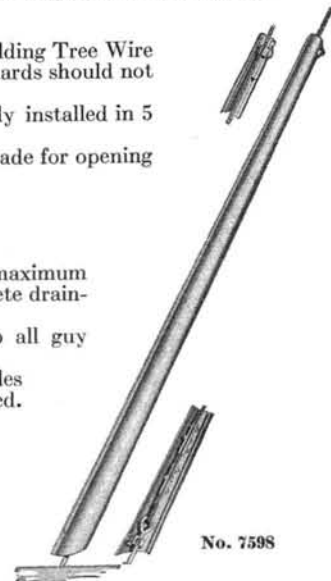

CONSTRUCTION MATERIAL**HUBBARD SERVISLEEVES
For Guy Strand**

For effectively and uniformly serving strand.

ServiSleeves overcome objections of cutting, clipping and crimping and prevent finger pinching. Easily and quickly installed, retain original shape and maintain rigid grip at all times. Just slips on and stays put. No special tools are needed.

Cat. No.	Size Strand Inches	Length Inches	Std. Pkg.	Ship. Wt., Lbs. per 100
7451	$\frac{3}{16}$	$1\frac{1}{4}$	100	2
7452	$\frac{1}{4}$	$1\frac{1}{4}$	100	3
7453	$\frac{5}{16}$	$1\frac{1}{2}$	100	7
7454	$\frac{3}{8}$	2	100	7
7455	$\frac{7}{16}$	$2\frac{1}{4}$	100	10
7456	$\frac{1}{2}$	$2\frac{1}{4}$	100	13

**HUBBARD GUY CLAMPS
Hot Galvanized**

Nos. 7447, 7448, 7449 and 7450 for strands $\frac{3}{16}$ to $\frac{3}{8}$ inch; made of hot rolled steel sections $1\frac{1}{16}$ inches wide by $\frac{3}{8}$ inch thick; $\frac{1}{2}$ inch bolts. No. 7450, W. U. Std.

Nos. 7461, 7462 and 7464, heavier types, for strands $\frac{5}{16}$ to $\frac{7}{16}$ inch, clamp section $1\frac{1}{2}$ inches wide by $\frac{3}{8}$ inch thick, have $\frac{5}{8}$ inch bolts. No. 7461 is A. T. & T. Co. standard.

No. 7460 for strands $\frac{3}{8}$ to $\frac{5}{8}$ inch; is a drop-forged steel section $2\frac{1}{8}$ inches wide by $\frac{1}{2}$ inch thick; with $\frac{5}{8}$ inch bolts. Clamp sections are so punched that all bolts are reversible in assembly.



No. 7461

Cat. No.	No. Bolts	Type	Size Strand Inches	Std. Pkg.	Wt. Lbs. per 100
7447	1	Light	$\frac{3}{16}$ to $\frac{3}{8}$	400	63
7448	2	Light	$\frac{3}{16}$ to $\frac{3}{8}$	175	122
7449	3	Light	$\frac{3}{16}$ to $\frac{3}{8}$	125	155
7450	3	Light	$\frac{3}{16}$ to $\frac{3}{8}$	75	226
7461	3	Heavy	$\frac{5}{16}$ to $\frac{7}{16}$	50	274
7462	2	Heavy	$\frac{5}{16}$ to $\frac{7}{16}$	100	174
7464	4	Heavy	$\frac{5}{16}$ to $\frac{7}{16}$	50	365
7460	3	Extra Heavy	$\frac{3}{8}$ to $\frac{5}{8}$	60	365



No. 7584

**HUBBARD GUY HOOKS
Hot Galvanized**

The No. 7584 Guy Hook is the N.E.L.A. and A.T.&T. Company's standard and is in general use, although the 2-bolt type is preferred by some construction men. For lighter work, the $3\frac{1}{2}$ -inch hook gives satisfactory results. Made of half oval steel, bent with the flat side to the pole, except No. 7583 $\frac{1}{2}$, which is formed from flat steel.



No. 7586

Cat. No.	Size Steel Inches	Length Inches	Diameter Holes, In.	Std. Pkg.	Wt. Lbs. per 100
7583 $\frac{1}{2}$	$1\frac{1}{4} \times \frac{1}{4}$	$3\frac{1}{4}$	$\frac{9}{16}$	450	39
7584	$1\frac{3}{4} \times \frac{3}{8}$	4	$\frac{1}{16}$	200	87
7585	$1\frac{1}{2} \times \frac{3}{8}$	$3\frac{1}{2}$	$\frac{9}{16}$	300	59
7586	$1\frac{1}{2} \times \frac{3}{8}$	6	$\frac{9}{16}$	200	88

CONSTRUCTION MATERIAL

PEIRCE TELEPHONE WIREHOLDERS

All-Porcelain Type

Combines a wall bracket, insulator and screw all in one. Used as a corner bracket where the lead from the pole comes to the building at an angle and as a standard house bracket for carrying the pairs on a straight run along the building or for dead-ending.

The double groove on the top makes an ideal arrangement for tying in twisted telephone pairs.

No metal is exposed after installation. The wireholder is not affected by atmospheric conditions and will not make rust stains on the house.



Cat. No.	Equipped with	Wire Hole Inches	Std. Pkg.	Wt. Lbs. per 100
1622	No. 20 x 2-In. Galv. Screw	$\frac{9}{16} \times \frac{3}{4}$	50	60
1632	No. 20 x 2-In. Brass Screw	$\frac{9}{16} \times \frac{3}{4}$	50	60

NO. 8918 HUBBARD SPAN CLAMPS

Hot Galvanized



Used when service connections are made at points between poles. Equipped with No. 8901 Suspension Clamp and Bolt. Insulator spacing, $5\frac{3}{4}$ inches.

Standard package, 100. Weight per 100, 138 pounds.

NO. 9214 PEIRCE PORCELAIN KNOBS FOR TELEPHONE RACKS

Made of brown glazed dry process porcelain.

The wire groove is divided by a fin which keeps the two wires of the twisted pair separated.



Cat. No.	Dimensions, Inches				Ship. Wt. Lbs. per 100
	Height	Diameter	Wire Groove	Bolt Hole	
9214	$1\frac{1}{2}$	$1\frac{3}{4}$	$\frac{3}{4}$	$\frac{25}{64}$	22.7

PEIRCE DISTRIBUTING KNOB RACKS

Hot Galvanized

For Telephone Wires

These racks furnish a secure but inexpensive means for distributing twisted pair telephone wires from cable poles. Nos. 2900, 2901 and 2902 are made with $1\frac{3}{4}$ -inch channel steel back. The holes take a $\frac{1}{2}$ -inch lag screw.

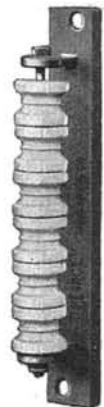

Cat. No.	No. of Knobs	Wt. Lbs. per 100
2900	4	348
2901	6	460
2902	8	545

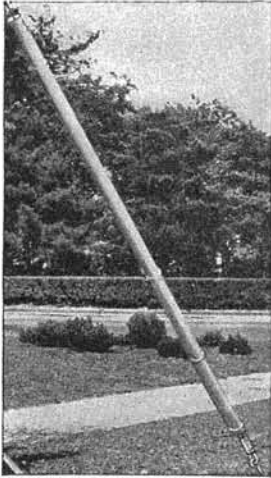
CONSTRUCTION MATERIAL**RAINIER JIFFY GUY WIRE GUARDS**

These guards assembled are hollow wooden cylinders, reinforced mechanically by the strand itself. The built-up construction adds to natural resilience of the wood. Held firm and compact by double wrapped, copperweld tie wires.

Made from clear, straight grained Douglas Fir.

Covered with aluminum paint which catches the eye and makes them highly visible at night.

Hollow wooden cylinder forms a chimney around the strand. At practically all times there is a natural draft of air which will dry both the strand and the inner wall of the guard.

These guards insulate the strand. There is no metallic contact even with the tie wires. This is of importance where line accidents cross the strand with conductor.

Guards can be included in carloads with crossarms; tie wires will not be affixed but will be sent parcel post.

Packed in standard bundles of 6.

7-Foot Length, Weight 6½ Pounds

8-Foot Length, Weight 7½ Pounds

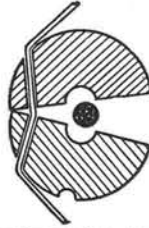

Lineman Opens Guard and Slips It Over the Guy Strand. Fastening Wires Act as Hinges.

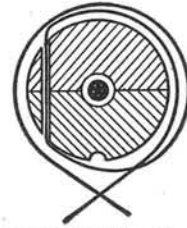

Correct Method to Wrap Fastening Wires. The Twist Will Be at the Safety Groove.

HUBBARD MECHANICAL GROUND ROD CLAMPS

For attaching either solid or stranded grounding wires to ground rods, galvanized pipe, or sub-station switching arms.

The clamps are made of high grade, corrosion-resisting, non-ferrous metal.

Five safety screw wrenches are furnished with every 100 clamps. No. 9496, one wrench with each five clamps.



Cat. No.	Size Rod Inches	Size of Wire	Ship. Wt. Lbs. per 100
9490	3/8	4-17 B&S Solid	25
9491	1/2	4-14 B&S Solid	30
9492	5/8	3/8" Strand to 8 B&S Solid	55

HUBBARD GROUND ROD MOULDS

Hubbard Ground Rod Moulds are used for making cast solder connections on ground rods. Both solid and stranded grounding wires can be attached to the ground rod by this method.

The moulds are drawn from sheet brass and are tinned for easy soldering. The collar fits snugly to the ground rod and prevents solder leakage.



Cat. No.	Diam., Inches		Std. Pkg.	Ship. Wt. Lbs. per 100
	Ground Rod	Top of Mould		
9480	3/8	15/16	25	2.75
9481	1/2	1 1/16	25	3.00
9482	5/8	1 3/16	25	3.25

CONSTRUCTION MATERIAL

HUBBARD COPPERWELD GROUND RODS



Briefly, the advantages derived from the use of Copperweld Ground Rods are:
 Smaller diameter, less earth displaced, easier to drive—a 4-pound hammer, with light blows, will drive the rod.

Long life, protection from rusting, welded copper.

Little time and field labor are required for installing Copperweld Rods and attaching the grounding wire. This saving will more than offset the difference in storeroom prices.

These ground rods are listed as standard by the Underwriters' Laboratories. Other lengths and diameters can be supplied.

Cat. No.	Diameter Inches	Length Feet	Std. Pkg.	Ship. Wt. Lbs. per 100
9415	$\frac{3}{8}$	5	10	200
9416	$\frac{3}{8}$	6	10	240
9425	$\frac{1}{2}$	5	10	340
9426	$\frac{1}{2}$	6	10	410
9427	$\frac{1}{2}$	7	10	480
9428	$\frac{1}{2}$	8	10	550
9429	$\frac{1}{2}$	9	10	615
9430	$\frac{1}{2}$	10	10	685

HUBBARD GROUND RODS

Without Copper Wire—Hot Galvanized



Made of stiff, high carbon open hearth steel, with long sharp points. Unwired rods are provided with holes through the upper ends for attaching grounding wires. These holes are located one inch from end of rods.

Cat. No.	Diam. Inches	Length Feet	Std. Pkg.	Wt. Lbs. per 100
9555	$\frac{3}{8}$	5	25	185
9556	$\frac{3}{8}$	6	25	223
9565	$\frac{1}{2}$	5	20	300
9566	$\frac{1}{2}$	6	20	360
9567	$\frac{1}{2}$	7	20	420
9576	$\frac{5}{8}$	6	10	600
9577	$\frac{5}{8}$	7	10	700
9578	$\frac{5}{8}$	8	10	800
9598	1	8	3	2133

HUBBARD GROUND RODS

With Copper Wire—Hot Galvanized

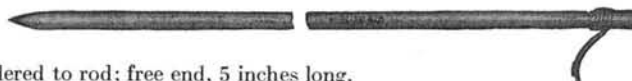

No. 12 wire soldered to rod; free end, 5 inches long.

Cat. No.	Diam. Inches	Length Feet	Std. Pkg.	Wt. Lbs. per 100
9505	$\frac{1}{2}$	5	25	332
9506	$\frac{1}{2}$	6	20	380
9516	$\frac{5}{8}$	6	10	600
9538	1	8	3	2200

CONSTRUCTION MATERIAL

HUBBARD LAG SCREWS

Hot Galvanized



Fetter Drive



Gimlet Point

Fetter drive lag screws have become practically standard for construction work because of their greater holding power. Threads do not tear the wood. Gimlet point screws will be furnished for $\frac{1}{4}$ -inch and $\frac{5}{16}$ -inch, fetter drive screws for $\frac{3}{8}$, $\frac{1}{2}$ and $\frac{5}{8}$ -inch.

Cat. No.	Lgth. In.	Std. Pkg.	$\frac{1}{4}$ -Inch		Lgth. In.	Std. Pkg.	Wt. Lbs. per 100
			Wt. Lbs. per 100	Cat. No.			
9722	2	6000	2.8	9722 $\frac{1}{2}$	2 $\frac{1}{2}$	5000	3.5
$\frac{5}{16}$ -Inch							
9732	2	4500	4.7	9733	3	2500	6.8
9732 $\frac{1}{2}$	2 $\frac{1}{2}$	3000	5.6	9733 $\frac{1}{2}$	3 $\frac{1}{2}$	2000	7.8
$\frac{3}{8}$ -Inch							
9742 $\frac{1}{4}$	2 $\frac{1}{4}$	3000	7.8	9744	4	1500	12.3
9742 $\frac{1}{2}$	2 $\frac{1}{2}$	2500	8.3	9744 $\frac{1}{2}$	4 $\frac{1}{2}$	1250	13.9
9743	3	2000	10	9745	5	1000	15.4
9743 $\frac{1}{2}$	3 $\frac{1}{2}$	1500	11.6	9746	6	800	17.1
$\frac{1}{2}$ -Inch							
9752 $\frac{1}{2}$	2 $\frac{1}{2}$	1200	16.7	9755	5	600	29.2
9753	3	1100	19	9755 $\frac{1}{2}$	5 $\frac{1}{2}$	550	30.8
9753 $\frac{1}{2}$	3 $\frac{1}{2}$	1000	21.3	9756	6	500	34.8
9754	4	800	23.6	9756 $\frac{1}{2}$	6 $\frac{1}{2}$	450	39.3
9754 $\frac{1}{2}$	4 $\frac{1}{2}$	700	25.3	9757	7	400	42.2
$\frac{5}{8}$ -Inch							
9764	4	550	37.7	9765 $\frac{1}{2}$	5 $\frac{1}{2}$	400	50.2
9764 $\frac{1}{2}$	4 $\frac{1}{2}$	500	41.8	9766	6	350	54.6
9765	5	450	46.0



HUBBARD DROP FORGED SCREW EYE BOLTS

Hot Galvanized

Has drop forged oval eye and 3 inches of gimlet lag screw thread.

Cat. No.	Length to Center of Eye, Inches	Diam. In.	Std. Pkg.	Wt. Lbs. per 100
9930	7	$\frac{1}{2}$	100	50
9931	7 $\frac{3}{4}$	$\frac{5}{8}$	100	75
9932	7 $\frac{3}{4}$	$\frac{3}{4}$	50	95

HUBBARD DOUBLE ARMING BOLTS

Hot Galvanized



The double arming bolt, used with four square washers, represents a much more economical means of tying crossarms together than the old method of a wooden block with a hole through it and a long machine bolt. The points are finished and four square nuts are included, but no washers.

CONSTRUCTION MATERIAL

HUBBARD DOUBLE ARMING BOLTS (Continued)

Cat. No.	Length, Inches		Std. Pkg.	Approx. Shipping Wt. Lbs. per 100	Cat. No.	Length, Inches		Std. Pkg.	Approx. Shipping Wt. Lbs. per 100
	Over All	Thread				Over All	Thread		
1/2-Inch									
9842	12	5	100	101	9850	20	8	100	133
9844	14	6	100	109	9852	22	8	50	148
9846	16	6	100	117	9854	24	8	50	156
9848	18	8	100	125					
5/8-Inch									
9862	12	5	50	150	9870	20	8	50	214
9864	14	6	50	166	9872	22	8	50	230
9866	16	7	50	182	9874	24	8	50	246
9868	18	8	50	198					
3/4-Inch									
9882	12	5	50	234	9890	20	8	25	328
9884	14	6	50	254	9892	22	8	25	348
9886	16	6	50	274	9894	24	8	25	368
9888	18	8	25	308					

HUBBARD DROP FORGED EYE BOLTS

Hot Galvanized



With drop forged oval eyes. All standard eye bolts are rolled threaded 6 inches except the 6-inch bolt which is rolled threaded 4 inches. The D.A. eye bolts have cut threads up to within 1 1/2 inches of the eye.

Cat. No.	Length to Center of Eye, Inches	Std. Pkg.	1/2-Inch—Size of Eye, Inside		Cat. No.	Length to Center of Eye, Inches	Std. Pkg.	Wt. Lbs. per 100
			Wt. Lbs. per 100	3/4 x 1-Inch				
9936	6	100	47		9944	14	100	95
9938	8	100	59		9946	16	100	107
9940	10	100	71		9948	18	100	119
9942	12	100	83		9950	20	100	131
5/8-Inch—Size of Eye, Inside								
1 1/2 x 2-Inch								
9956	6	100	103		9964	14	50	158
9958	8	100	115		9966	16	50	170
9960	10	100	127		9968	18	50	182
9962	12	50	146		9970	20	50	194
3/4-Inch—Size of Eye, Inside								
1 1/2 x 2-Inch								
9976	6	50	116		9984	14	50	218
9978	8	50	140		9986	16	50	234
9980	10	50	164		9988	18	50	250
9982	12	50	188		9990	20	50	266
5/8-Inch Double Arming Eye Bolts—3 Nuts								
Cat. No.	Length to Center of Eye, Inches	Std. Pkg.	Weight Pounds per 100					
9786	16	50	194					
9788	18	50	214					
9790	20	50	234					
3/4-Inch Double Arming Eye Bolts—3 Nuts								
Cat. No.	Length to Center of Eye, Inches	Std. Pkg.	Weight Pounds per 100					
9796	16	25	284					
9798	18	25	308					
9800	20	25	330					

CONSTRUCTION MATERIAL**HUBBARD MACHINE AND CROSSARM BOLTS**

Hot Galvanized



Hubbard Machine and Through Bolts, unless otherwise specified, are furnished with rolled threads which insure a perfect nut fit the full length of the thread.

3/8-Inch Machine Bolts

Cat. No.	Length Inches	Length Thread Inches	Std. Pkg.	Weight Pounds per 100	Cat. No.	Length Inches	Length Thread Inches	Std. Pkg.	Weight Pounds per 100
9603	3	3	1500	12.6	9605	5	3	800	18.3
9603 1/2	3 1/2	3	1250	14.3	9605 1/2	5 1/2	3	750	19.8
9604	4	3	1000	15.7	9606	6	3	650	21.4
9604 1/2	4 1/2	3	900	17.2					

1/2-Inch Machine Bolts

9704 1/2	4 1/2	3	550	31.3	9710	10	4	150	69.3
9704 3/4	4 3/4	3	500	33	9712	12	6	150	78
9705	5	3	500	37.8	9714	14	6	150	83.3
9706	6	3	400	41	9716	16	6	150	96.6
9707	7	3	400	47.2	9718	18	6	100	110
9708	8	4	350	55.1	9720	20	6	100	121

5/8-Inch Crossarm Bolts

9808	8	4	100	91	9820	20	6	50	178
9810	10	4	100	103	9822	22	6	50	192
9812	12	6	100	115	9824	24	6	50	206
9814	14	6	100	129	9826	26	6	50	220
9816	16	6	100	143	9828	28	6	50	234
9818	18	6	50	164					

3/4-Inch Machine Bolts

9908	8	4	50	150	9920	20	6	50	246
9910	10	4	50	166	9922	22	6	25	276
9912	12	6	50	182	9924	24	6	25	292
9914	14	6	50	202	9926	26	6	25	308
9916	16	6	50	214	9928	28	6	25	324
9918	18	6	50	230					

HUBBARD CARRIAGE BOLTS

Hot Galvanized



Carriage bolts are used for attaching the braces to crossarms on most overhead lines. Standard heads, square nuts, rolled threads.

3/8-Inch

Cat. No.	Length, Inches		Std. Pkg.	Weight Pounds per 100	Cat. No.	Length, Inches		Std. Pkg.	Weight Pounds per 100
	Over All	Thread				Over All	Thread		
9633	3	1 3/4	1500	13.2	9635	5	1 3/4	800	18.2
9633 1/2	3 1/2	1 3/4	1250	14	9635 1/2	5 1/2	1 3/4	750	19.5
9634	4	1 3/4	1000	15.7	9636	6	1 3/4	700	21.6
9634 1/2	4 1/2	1 3/4	900	17.2					

1/2-Inch

9643	3	2 1/2	800	24.7	9645	5	3	450	35.1
9643 1/2	3 1/2	3	700	26.6	9645 1/2	5 1/2	3	400	37.5
9644	4	3	600	29.3	9646	6	3	350	40
9644 1/2	4 1/2	3	500	32.4					

CONSTRUCTION MATERIAL

HUBBARD FLAT CROSS ARM BRACES

Hot Galvanized



Made only from new open hearth steel.

Cat. No.	Length Inches	Ship. Wt. Lbs. per 100	1 1/2 x 1/32-Inch		Cat. No.	Length Inches	Ship. Wt. Lbs. per 100
8020	20	142			8028	28	198
8022	22	156			8030	30	212
8024	24	170			8032	32	226
8026	26	184		
1 1/4 x 1/4-Inch							
8120	20	167			8128	28	233
8122	22	183			8130	30	250
8124	24	200			8132	32	266
8126	26	216		

HUBBARD VERTICAL BRACES

Cat. No.	No. of Arms	Length Over All Inches	Spacing Inches	Size Angle Inches	Ship. Wt. Lbs. per 100
7976	2	20	18	1 1/2 x 1 1/2 x 3/16	300
7977	3	38	18	1 1/2 x 1 1/2 x 3/16	520
7978	4	56	18	1 1/2 x 1 1/2 x 3/16	840
7986	2	26	24	1 1/2 x 1 1/2 x 3/16	380
7987	3	50	24	1 1/2 x 1 1/2 x 3/16	700
7988	4	74	24	1 1/2 x 1 1/2 x 3/16	1040



HUBBARD ROUND WASHERS

Hot Galvanized

Washers are cleanly cut and are galvanized in such a manner as to insure a heavy, even coat of pure zinc with no large drops to interfere with the fit of the bolt or nut.

Cat. No.	O.D. In.	Size Hole In.	Thickness Inches	For Bolt Size Inches		Weight Pounds per 100	Std. Pkg.
				Mach.	Carriage		
7801	1	7/16	5/64	3/8	..	1.6	15000
7802	1 1/4	1/2	5/64	..	3/8	2.6	7000
7803	1 3/8	9/16	7/64	1/2	3/8	4.2	5000
7805	1 3/4	1 1/16	1/8	5/8	1/2	8.4	2500
7806	2	1 3/16	1/8	3/4	5/8	11	2000

HUBBARD SQUARE WASHERS

Hot Galvanized

Washers are cleanly cut and are galvanized in such a manner as to insure a heavy, even coat of pure zinc with no large drops to interfere with the fit of the bolt or nut.



Cat. No.	Dimensions Inches	Diam. of Hole, In.	For Bolt Size, In.	Std. Pkg.	Wt. Lbs. per 100
7812	2 x 2 x 1/8	1 1/16	1/2 or 5/8	1500	14
7814	2 1/4 x 2 1/4 x 3/16	1 3/16	5/8 or 3/4	1000	22.7
7816	3 x 3 x 3/16	1 3/16	5/8 or 3/4	500	45.8
7817	3 x 3 x 1/4	1 3/16	5/8 or 3/4	350	62.3
7818	4 x 4 x 3/16	1 3/16	5/8 or 3/4	250	87.5
7819	4 x 4 x 1/4	1 5/16	3/4 or 7/8	200	115
7820	4 x 4 x 1/2	1 3/16	1	100	220
7826	3 1/2 x 3 1/2 x 3/8	1 5/16	3/4 or 7/8	200	124
7827	6 x 6 x 3/8	1 3/16	1	100	370

CONSTRUCTION MATERIAL

CRAPO GALVANIZED STEEL STRAND GUY WIRE 7 Wires Twisted Into a Single Strand

Diameter Inches	Size of Wires	Weight Pounds per 1000 Feet	Standard Single and Double Galvanized		Siemens-Martin Double Galvanized Strength Pounds
			Strength Pounds	Price 100 Ft.	
5/8	6	813	11600	\$8.50	19100
1 1/2	8	517	7400	5.50	12100
7/16	9 1/2	399	5700	4.50	9350
3/8	11	296	4250	3.50	6950
5/16	12	205	3200	2.50	5350
1/4	14	121	1900	1.75	4250
3/16	16	72.9	1150	1.25	3150
9/32	17	51.3	870	1.15	1900

Diameter Inches	Size of Wires	Weight Pounds per 1000 Feet	High Strength Strand Double Galvanized		Extra High Strength Strand Double Galvanized Strength Pounds
			Strength Pounds	Price 100 Ft.	
5/8	6	813	29600	\$12.00	42400
1 1/2	8	517	18800	7.25	26900
7/16	9 1/2	399	24500	6.00	20800
3/8	11	296	10800	4.40	15400
5/16	12	205	8000	3.20	11200
1/4	14	121	4750	2.25	6650
3/16	16	72.9	2850	1.80	3990



Special Strength Specification Strand Double Galvanized

Approx. Diam. In.	Trade Name	A. T. & T. Spec. No.	W. U. Spec. No.	Packing Lgths. Feet	Wt., Lbs. per 1000 Feet	Ult. Strength Lbs.
3/16	2200-Lb. Strand	6001	*500, 100	72.9	2400
9/32	4000-Lb. Strand	807A	†2500, 500	164	4000
7/16	6000-Lb. Strand	6001	807A		205	6000
3/8	10000-Lb. Strand	6001	807A	*500	296	11500
7/16	16000-Lb. Strand	6001	807A	†1000, 2500 and 5000	400	18000

* On coils. † On reels.
Also furnished in 1-mile length or multiples thereof.

EXTRA DOUBLE GALVANIZED TELEPHONE AND TELEGRAPH WIRE

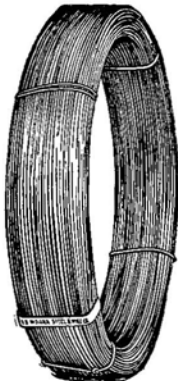

The Indiana Steel & Wire Company's process of galvanizing (Crapo Patents) overcomes the inherent defects in certain grades of galvanized wire, more especially those which approach pure iron. The use of the process results in a perfect mechanical bond between the zinc coating and the iron base metal, thus insuring a protective coating which will not crack or peel even if the wire is bent, or twisted abruptly, as when wrapped around its own diameter.

Aside from the introduction of a molten salt treating bath which in no way adversely affects the finished product, the process follows closely the old standard hot-dip method of applying a zinc coating. The molten salt bath is of such composition as to prepare the surface of the iron base metal so that after being made chemically clean, fluxed and dipped in the molten zinc, the resulting galvanizing is thick, non-peeling, and contains the maximum amount of pure zinc which means the best possible protection against corrosion.

Extra Best Best (E. B. B.) is highest in electrical conductivity, having a range of electrical resistance of 4700 to 5000 mile ohms.

Best Best (B. B.). Slightly higher in resistance than E. B. B. but combines conductivity with tensile strength to make a popular grade, having a maximum electrical resistance of 5600 mile ohms.

Steel is designed for short-line service, where electrical conductivity can be sacrificed for tensile strength. Maximum resistance 6500 mile ohms.

All grades galvanized under the same improved process.

Size B.W.G.	Diam. In.	Wt., Lbs. per Mile	Miles Wire in Bundle	Approx. Breaking Strain, Lbs.		
				E. B. B.	B. B.	Steel
4	.238	811	1/4	2028	2271	2433
6	.203	590	1/8	1475	1652	1770
8	.165	390	1/2	975	1092	1170
9	.148	314	1/2	785	879	942
10	.134	258	1/2	645	722	774
11	.120	206	1/2	515	577	618
12	.109	170	1/2	425	476	510
14	.083	99	1/2	247	277	297

Prices upon application.

CONSTRUCTION MATERIAL

NEVER-CREEP ANCHORS

The Never-Creep Anchor consists of a 1-piece rod and 1-piece malleable iron plate that pulls against the solid undisturbed earth.

It possesses all the merits of the dead-man but eliminates the necessity of digging a pit and cutting a channel.

To install, simply bore the hole, drive the rod and hang on the plate.

Cat. No.	Size Plate In.	Wt. Lbs. per 100	Cat. No.	Size Plate In.	Wt. Lbs. per 100
510	5 x 10	376	825	8 x 25	1960
615	6 x 15	690	830	8 x 30	2670
620	6 x 20	925	835	8 x 35	3095
820	8 x 20	1240	1040	10 x 40	4775



Twineye Rods

Cat. No.	Size	Wt. Per 100	Cat. No.	Size	Wt. per 100
360	3/4" x 6'	970	170	1" x 7'	2160
370	3/4" x 7'	1130	180	1" x 8'	2310
380	3/4" x 8'	1255			

Thimbleye Rods

Cat. No.	Size	Wt. per 100	Cat. No.	Size	Wt. per 100
25	1/2" x 5'	390	36	3/4" x 6'	960
26	1/2" x 6'	400	37	3/4" x 7'	1120
56	5/8" x 6'	680	38	3/4" x 8'	1245
57	5/8" x 7'	755	17	1" x 7'	2150
58	5/8" x 8'	830	18	1" x 8'	2300



CHANCE SCREW ANCHORS

This socket type screw anchor is made of semi-steel. Improvements include a wide spiral correctly pitched for ease of installation, a wide helix and sharp blades.

May be installed with a standard screw anchor wrench with adapter attachment which will be sent on request.



Cat. No.	Size In.	Size Rod In.	Wt. Lbs. per 100
126	6	1/2	988
586	6	5/8	1120
587	7	5/8	1323
347	7	3/4	1650
588	8	5/8	1680
348	8	3/4	1980
5810	10	5/8	2170
3410	10	3/4	2455

CHANCE HEAVY TELEGRAPH AUGERS

With Telescoping Handle

With reamer bit for increasing size of hole 4 in.

Cat. No.	Size In.	Wt. Lbs. Each
610	6 to 10	26
812	8 to 12	28

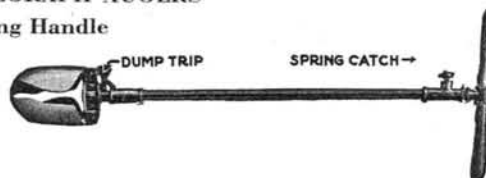

CONSTRUCTION MATERIAL

WEJ-LOCK EXPANDING ANCHORS

The Wej-Lock Balanced Anchor may be used as an expanding anchor, a cone anchor or as a dead man. When spread or partially spread, it is cone shaped, developing equalized strain which is responsible for its exceptional holding power. It is the only malleable iron expanding anchor with a nut retainer.

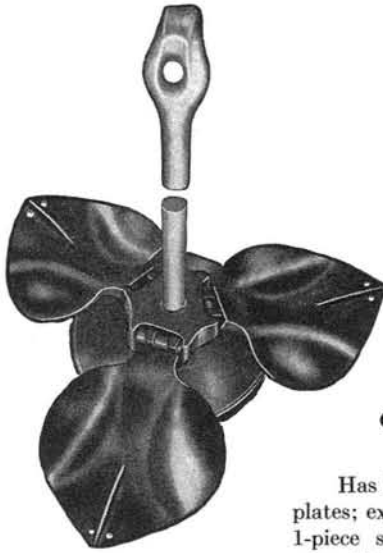

Cat. No.	Size Anchor	Size Rod	Wt. Lbs. per 100
836	8"-3 Way	3/4"	1350
8310	8"-3 Way	3/4"	1548
8412	8"-4 Way	3/4"	1690
1044	10"-4 Way	1"	3000

CHANCE NEW IMPROVED EXPANDING ANCHORS

Has both housing and base for supporting plates; expanding arms hinged to cross head by 1-piece spider; interlocking plates; expanding arms hinged to plates by clinched loops; wide deep ribbed expanding arms; drop-forged expanding head; marginal guideways for guiding plates and holding anchor together.

Cat. No.	Size Anchor	Max. Rod	Wt. Lbs. per 100
62	6"-2 Way	5/8"	485
64	6"-4 Way	3/4"	735
824	8"-2 Way	3/4"	935
82	8"-2 Way	3/4"	1015
8410	8"-4 Way	3/4"	1445
84	8"-4 Way	3/4"	1588
104	10"-4 Way	1"	2550
124	12"-4 Way	1 1/4"	4175

CHANCE PYRAMID CONE ANCHORS

This improved cone anchor has 6 flat faces which in conjunction with the wedging portions act as a flat wedge without danger of rotation. The flaring base gives a final grip to the wedge thus greatly increasing the holding power.

Cat. No.	Size In.	Max. Size Rod In.	Wt. Lbs. per 100
6	6	5/8	320
8	8	3/4	668
10	10	3/4	1015
12	12	1	1690
16	16	1	2830
19	19	1 1/4	4760
23	23	1 1/4	6550

HUBBARD GUY THIMBLES
Hot Galvanized

Cat. No.	Size Strand Inches	Size Guy Rod Inches	Std. Pkg.	Wt. Lbs. per 100
7593	3/8	1/2 and 5/8	1000	11
7594	1/2	5/8 and 3/4	500	21
7595	5/8	1	250	42

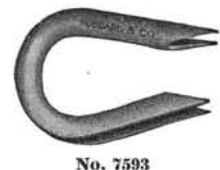

No. 7593

CONSTRUCTION MATERIAL

EVERSTICK EXPANDING ANCHORS

Ease of installation, ease of expansion, maximum power and long life are the result of years of experience and improvements in these anchors.

The exclusive Everstick guides hold the plates in perfect alignment during expansion of the anchor.

Anchors are made of certified malleable iron.

2-WAY ANCHORS

This anchor can be depended upon to give outstanding service in comparison to any anchor of like size and capacity.

For many uses in pole line construction.

No.	Anchor and Hole In.	Size Rod Inches	Area Expanded Sq. In.	Anchor Wt. Lbs.	Holding Power Pounds	
					Ordinary Soil	Firm Soil
52	5	$\frac{5}{8}$	30	4	2000	3000
62	6	$\frac{5}{8}$	55	7	3000	6000
82	8	$\frac{3}{4}$	100	10	7000	14000

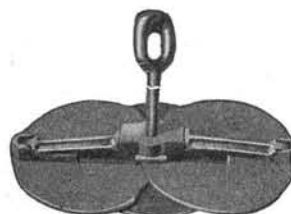

Expanded

3-WAY ANCHORS

An ideal guy anchor for all around use. Built to hold strains 100 per cent greater than rated holding power for ordinary soils.

A 6 and 10-inch anchor can be furnished proportionately designed for minimum and maximum strain requirements.

No.	Anchor and Hole In.	Size Rod Inches	Area Expanded Sq. In.	Anchor Weight Lbs.	Holding Power Pounds	
					Ordinary Soil	Firm Soil
633	6	$\frac{5}{8}$	65	$6\frac{1}{2}$	3000	6000
833	8	$\frac{5}{8}$	75	$7\frac{1}{2}$	3000	6000
834	8	$\frac{5}{8}$	90	9	4000	8000
836	8	$\frac{3}{4}$	110	11	8000	16000
8310	8	$\frac{3}{4}$	125	13	10000	20000
8312	8	1	130	14	12000	24000
10316	10	1	170	25	20000	40000

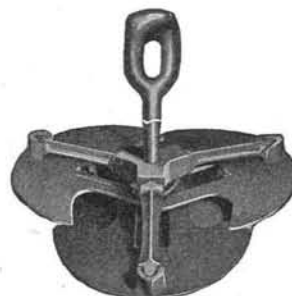

Expanded

4-WAY ANCHORS

Recommended for heavy duty anchorage and long service under the most severe conditions.

Ease of expansion and great holding power are features of this anchor.

No.	Anchor and Hole In.	Size Rod Inches	Area Expanded Sq. In.	Anchor Weight Lbs.	Holding Power Pounds	
					Ordinary Soil	Firm Soil
64	6	$\frac{3}{4}$	70	9	4000	8000
84	8	$\frac{3}{4}$	125	15	10000	20000
84	8	1	132	$15\frac{1}{2}$	12000	24000
104	10	1	210	28	20000	40000
124	12	$1\frac{1}{4}$	320	54	32000	64000



Expanded

NO. 7546 HUBBARD ROCK GUY BOLTS

Hot Galvanized



Used where solid rock extends to surface or in stone or concrete walls. Of 1" round steel, 18" long, with drop forged eye ($1\frac{1}{2}$ x 2" inside). Std. pkg., 20. Ship. wt., 600 lbs. per 100.

CONSTRUCTION MATERIAL**NO. 7547 HUBBARD ROCK GUY BOLTS**

With Wedge—Hot Galvanized



Has wedge and split end which spreads bolt as wedge is driven against bottom of hole. Of 1-inch round steel, 18" long. Standard package, 20. Shipping weight, 600 pounds per 100.

HUBBARD STEELWING ANCHORS

Hot Galvanized

Having large bearing surfaces with sharp screw edges, these anchors are easily installed and provide efficient and substantial anchorage against undisturbed earth; will not creep. No digging required; no adjustments under ground necessary.

Cat. No.	Diameter Inches		Overall Length Rod Feet	Std. Pkg.	Ship. Wt., Lbs. per 100
	Wing	Rod			
7524-A	4	3/4	4 1/2	10	738
7526-A	6	3/4	5 1/2	10	1040
7527-A	7	1	5 1/2	10	1750
7528-A	8	1	5 1/2	10	1860
7530-A	10	1 1/4	5 1/2	10	2900
7550-A	10	1 1/4	8	5	3690

To obtain anchor with thimbleye, drop A from catalog number.

**HUBBARD STEELWING SWAMP ANCHORS**

Hot Galvanized

These anchors have enormous holding power when embedded the proper depth in swampy soil.

Anchor unit consists of solid steelwing, short solid steel shaft threaded to take 1 1/4-inch pipe coupling and 1 1/4-inch pipe cap with forged eye to screw onto pipe extension shaft. Pipe is cut to meet anchor requirements but is not furnished as part of anchor.

Over all length, length of pipe used plus 10 inches. Size strand, 1/2 inch or under.



Cat. No.	Diam. Wing In.	Diam. Shank	Std. Pkg.	*Ship. Wt., Lbs. per 100
7548	8	Std. 1 1/4" Pipe	3	920
7549	10	O.D. 1.66"	2	1370

* Not including pipe and coupling.

OSHKOSH DIGGERS

The blades are made of special alloy steel. Welding is used for attaching the blades instead of riveting, making a durable joint. The fulcrum members are of heavily constructed, channel-shaped, steel forgings.

There are two pivot points for the blades, one on each side. This gives much stronger leverage and greater durability.

Made in two types, with split handles or with two solid handles. The handles are made of straight grained hard wood, 8 feet long.

Measurement marks are placed on the handles so that the workman can easily determine the exact depth of the hole.

The diameter of the circle circumscribed by the digger blades is 6 inches.

No. 2050, Split Handle Type, Wt., 13 lbs.

No. 2051, Two Solid Handle Type, Wt., 14 1/2 Lbs.



No. 2051

GLASS INSULATORS

NO. 9 HEMINGRAY GLASS INSULATORS

Pony

Over all: height, 3 $\frac{3}{4}$ " ; diameter, 2 $\frac{1}{4}$ " .

Diameter Groove.....	inches	$\frac{3}{8}$
Weight, Each.....	pounds	$\frac{9}{16}$
Quantity per Box.....		250
Weight per Box.....	pounds	162



NO. 10 HEMINGRAY GLASS INSULATORS

Exchange Line

Over all: height, 3 $\frac{1}{4}$ " ; diameter, 2 $\frac{1}{2}$ " .

Diameter Groove.....	inches	$\frac{7}{16}$
Quantity per Box.....		250
Weight per Box.....	pounds	176



NO. 12 HEMINGRAY GLASS INSULATORS

Double Groove, Pony

Over all: height, 3 $\frac{5}{8}$ " ; diameter, 2 $\frac{3}{8}$ " .

Diameter Top Groove.....	inches	$\frac{3}{8}$
Weight, Each.....	pounds	$\frac{5}{8}$
Quantity per Box.....		250
Weight per Box.....	pounds	188



NO. 14 HEMINGRAY GLASS INSULATORS

Deep Groove, Double Petticoat, Pony

Over all: height, 3 $\frac{3}{8}$ " ; diameter, 2 $\frac{7}{8}$ " .

Diameter Groove.....	inches	$\frac{3}{8}$
Weight, Each.....	pounds	$\frac{3}{4}$
Quantity per Box.....		200
Weight per Box.....	pounds	160



NO. 16 HEMINGRAY GLASS INSULATORS

Long Distance

Over all: height, 4" , diameter, 2 $\frac{5}{8}$ " .

Diameter Groove.....	inches	$\frac{3}{8}$
Weight, Each.....	ounces	15 $\frac{1}{2}$
Quantity per Box.....		175
Weight per Box.....	pounds	185



NO. 43 HEMINGRAY GLASS INSULATORS

Top Groove, Western Union

Over all: height, 4 $\frac{1}{4}$ " ; diameter, 3 $\frac{5}{8}$ " .

Diameter Groove.....	inches	$\frac{5}{16}$
Weight, Each.....	ounces	25
Quantity per Box.....		100
Weight per Box.....	pounds	199



KILEY TRUCK BODIES

TYPE GU GENERAL UTILITY BODIES

For Mounting on Any ½-Ton Commercial Chassis

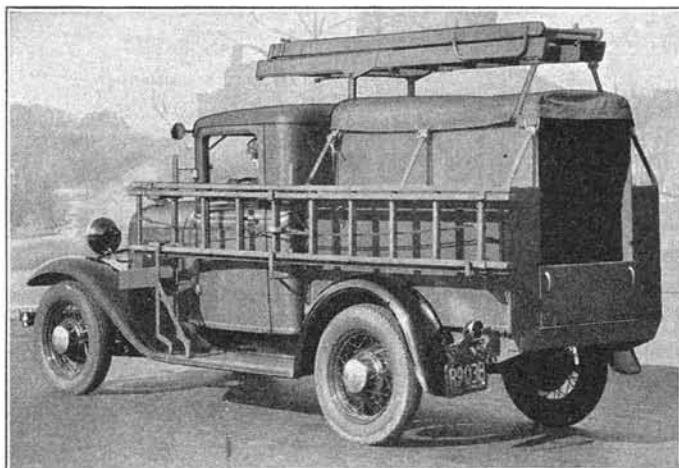

Standard Line Construction Bodies

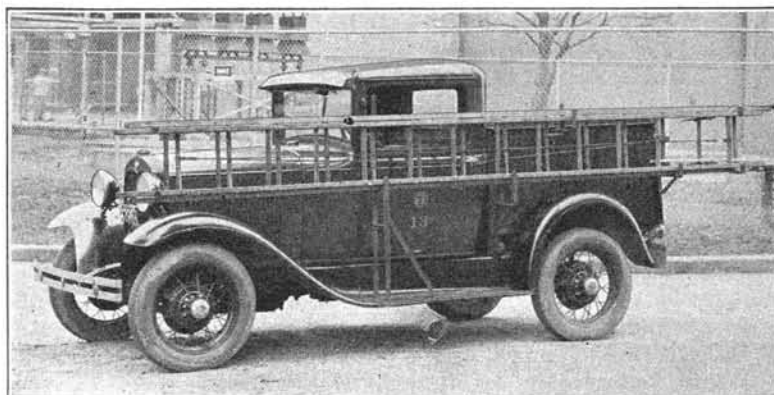

Type LI Standard Installation Bodies

KILEY TRUCK BODIES**TYPE GU GENERAL UTILITY BODIES****For Mounting on Any ½-Ton Commercial Chassis**

A new design in light duty line, meter installation, trouble shooter or general utility body. Made of special pressed steel construction, which insures strength and light weight, this unit has replaced, in some instances, 1½-ton units with satisfactory operation.

The body complete weighs less than 500 pounds.

The unit consists of:

Two side cabinets, 9 x 28 x 60 inches, with full size metal doors opening to outside of body.

The right cabinet is regularly equipped with two adjustable partition trays and eight permanent compartments, while the rear section contains complete set of tool holders for all standard line tools.

Left side cabinet contains no standard equipment; may be arranged for electric meter trays, test meters, etc.

The center loading space, 28 x 60 inches, can be readily used in emergency work for carrying reels, transformers, or in general use for carrying electric refrigerators, etc.

The floor of this body is about 26 inches above ground.

Tailgate—all steel construction—slam type.

Tarpaulin—heavy waterproof cover with spring steel tarpaulin bows securely fastened in same.

Ladder irons conform to latest approved method for carrying ladders. The ladder rests on the lower rail and is steadied by bracket under top rail. A spring clamp is provided to hold ladder securely, yet it is readily dismantled.

The lower section of ladder brackets provides space for sectional tree trimmers, lamp pickers, or ground rods.

Write for details.

STANDARD LINE CONSTRUCTION BODIES

A special line construction body which is light and durable. The cabinets, compartments, and equipment have been modified for power company use. The bodies can be supplied of all metal construction if desired.

Standard body consists of:

Oak floor platform, protected by steel plates bolted securely to pressed steel bearers.

Rear-I-Beam so arranged that winch and derrick equipment could be added in future if necessity demanded it. Information regarding equipment necessary for use with winch and derrick furnished upon application.

Heavy rear fenders.

Rear steps.

Upper side boxes on right and left with full set of tool holders and material compartments. The material bins for small goods are made adjustable to meet variable requirements. Covers have continuous steel hinges with ¼-inch steel pin.

Lower side boxes on right and left.

Thru cant hook box with doors on each side of body.

Weatherproof rubber goods cabinet with doors on each side of body.

Digging bar box.

Overhead structure complete with racks for ladder, pike poles, material chains, snatch block rail, straps, etc.

Top bows and bow carrier.

Formed 3-piece tarpaulin with stationary bellows type section between cab and body.

Tarpaulin carrier.

Standard body sizes, 8'6", 10 and 12 feet.

TYPE LI STANDARD INSTALLATION BODIES

For maintenance and troubleman's service.

Body, size 60 x 46 x 28 inches, consists of:

Front compartment, size 46 x 25½ x 28 inches, has large door opening on right side and one horizontal and one vertical partition.

Rear compartment, size 46 x 34½ x 28 inches, has double rear door opening.

Right section rear has two stationary shelves and five sliding trays.

Left section rear has one horizontal and one vertical partition.

Rear doors contain racks for tools and insulator tubes.

This unit has an all steel under body.

A complete set of ladder irons, including ladder clamp and rack, is mounted on left side.

Can be mounted on any ½-ton commercial chassis.

It can be modified and equipped for almost any special service.

GRAYBAR UTILITY AUTOMOBILE POLE DERRICKS

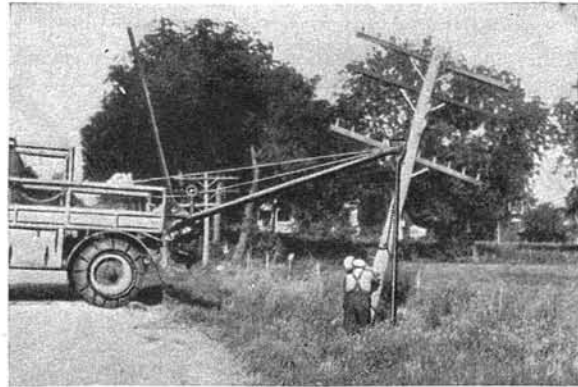

Middle Type Derricks which are used for general derrick work, center over the middle of the rear of the trucks. Only two men are required to operate this type of derrick; one man operates the winch and the other guides the pole. The middle type derrick is raised and adjusted with the winch. When used as a stiff leg assembly an old pole may be removed from the ground without preliminary digging unless it is firmly embedded or has an abnormal flare. When not in use, the derrick may be disassembled and carried on the side of the truck body, where it is out of the way.

The Corner Type Derrick which works at the right rear corner of the truck body facilitates derrick work in alleys and other restricted places where it is not possible to use the middle type to good advantage. Operating characteristics are practically the same as the middle type.

A complete derrick assembly includes:

Derrick Proper	1 Foot Plate
1 Right Hand Side Leg	2 Connecting Pins, Key, Snap and Chain
1 Left-Hand Side Leg	1 Rear Spindle and Sheave (Length to Suit Truck Body)
1 Middle Leg, Upper Section	*1 Tail Bolt Assembly
1 Middle Leg, Middle Section	*2 Front Supports for Spindle
1 Middle Leg, Lower Section	*1 Floor Pocket
1 Apex, Pin Key, Snap and Chain	1 Winch Line Hook for End of Winch Line
1 Floor Pocket Bolt	

* Designated as metal parts for attaching to truck body.

Type	Each	Lift Feet	†Handles Poles Length Feet	‡Weight Pound
XLM	17½	35	285
LM	20	45	385
HM	22½	55	570
LC	20	45	380
HC	22½	55	570
2870	28	70	750
T	21	45	595

† Length of poles handled depends on the balance point of each pole.

‡ Weight does not include the weight of boxing nor body parts such as tail bolt assembly, spindle and sheave.

ADJUSTABLE TYPE

The standard types are provided with a foot piece for lower end of middle leg, which fixes the position of the derrick head and overhang at rear of truck.

Many times a bank on which a pole is placed or to be placed, or a hedge or deep gutter has prevented the truck being so placed as to be of service.

The Adjustable Type Derrick can be changed from one extreme position to the other without the telescoping center leg becoming disengaged. All positions are fixed by the use of pins.

CONSTRUCTION MATERIAL

NO. 1354 GRAYBAR SINGLE DRUM WINCHES

10,000-Pound Capacity

The No. 1354 (Type L-12) Graybar Winch is a modification of the regular standard single drum winch and is used for every purpose which requires pulling rope on a drum, operating cranes, pole setting derricks and for hoisting and hauling. This type winch is particularly popular for use on light model trucks where the use of a large winch-drum is not required and not much space is available for mounting.

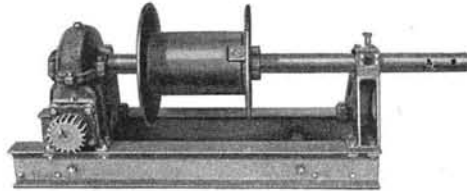

No brake nor clutch is required on this winch, for the winch cannot run free; the winch is driven when pulling and also when lowering.

This winch embodies all of the best features of the more expensive Graybar Winches. It is flexible, light in weight, and built for hard service. To keep the weight to a minimum and assure a greater factor of safety, only high grade heat treated alloy steels and electric steel castings are used in its construction.

Intermittent Capacity, Single Line.....	pounds	10,000
Continuous Capacity, Single Line.....	pounds	5,000
Diameter of Drum.....	inches	8
Diameter of Drum Flange.....	inches	19
Approximate Space Required Back of Cab.....	inches	20
Weight, Winch Only.....	pounds	430
Approximate Weight, with SAE Power Take-Off.....	pounds	480
Approximate Weight, with Propeller Shaft Power Take-Off.....	pounds	730

Rope and Cable Capacity

Size.....in.	$\frac{3}{16}$	$\frac{1}{2}$	$\frac{5}{8}$	$\frac{3}{4}$	1
Material.....	Steel	Steel	Steel	Manila	Manila
No. of Feet.....	720	600	384	264	156

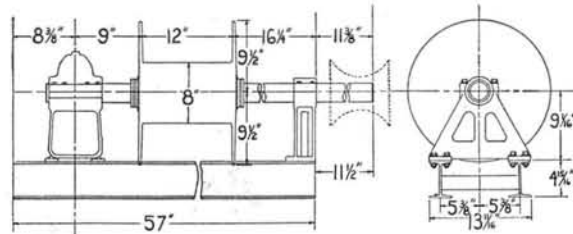

TYPE CR GRAYBAR COLLAPSIBLE POWER REELS

The Type CR Collapsible Power Reel is designed to pick up loose wire in a neat coil. It is light in weight, but sturdy in construction, and is attached to the winch in a short time. The reel arms and the spiders supporting them are made of aluminum alloy castings which insure light weight as well as strength. The spindle to which the spider is attached is made of seamless steel tubing fitted with a bayonet socket lock for attaching to the winch shaft.

The CR Collapsible Power Reel is simple in operation. All Graybar Winches have a hole drilled through the extended end of the shaft into which a pin is driven, leaving one end protruding from the shaft over which the reel spindle is pushed in place and locked by a quarter turn of the reel. The lever on the outside of the reel is turned to the right expanding the reel to working position. When the wire is ready for removal, the lever is turned to the left, contracting the reel arms and allowing the wire to be taken off in a neat compact roll.

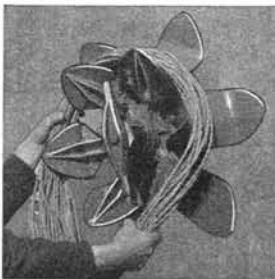
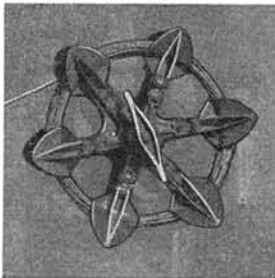

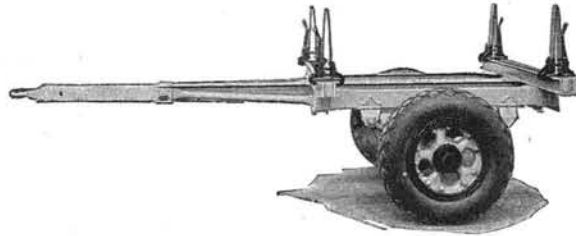
TRAILERS AND POLE DINKEYS**GRAYBAR 3 TO 7-TON 2-WHEEL TRAILERS**

These trailers are equipped with extension tongues, which enable them to handle poles of any length. The tongue is fitted with a pintle eye, which fits into the pintle hook at the rear of the truck. It telescopes within itself to accommodate either long or short poles, and can be adjusted to balance the trailer for easy hand moving when the trailer is empty.

All trailers of this series are equipped with two stationary bolsters on which are sliding up-rights. These up-rights, which facilitate the proper placing of large or small loads on the trailer, are positively locked into position by quick acting cams. At the rear of the trailer is the small hand winch which is used for tightening the cable which binds the load.

Specifications				
Model.....	1370	M	H	XH
Capacity..... tons	2	3	5	7
Tread..... in.	56	56	58	60
Standard Tires, Solids..... in.	34x4	36x5	36x8	36x10
Pneumatic Tires, Extra..... in.	32x6	36x8	38x9
Dual Tires, Extra..... in.	30x5	32x6	36x6
Dual Tires, Extra..... in.	36x6	38x9.75
Width Overall..... in.	70	72	80	82
Frame..... in.	4	5	6	7
Springs..... leaves	7	8	12	12
Width of Springs..... in.	3½	3½	3½	4
Length of Springs..... in.	43½	43½	43½	43½
Tongue Extension..... ft.	10¼	11⅔	11⅔	11⅔
Weight..... lbs.	1825	2145	2860	3850

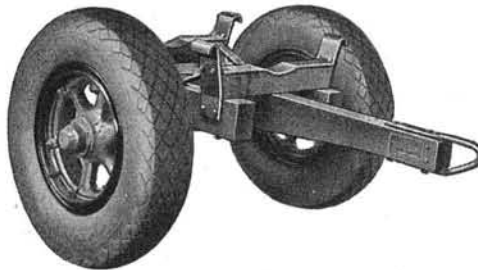
GRAYBAR POLE DINKEYS

Pole dinkeys, Models C-1 and C-3 are constructed to stand the rough handling such a unit must necessarily receive. The bunks are faced with heavy steel strips and the woodwork is of well seasoned hard wood.

Specifications			
Model.....	C-1	C-3	1369
Capacity..... tons	1	3	½
Standard Tires, Solids..... in.	34x3	32x5
Standard Tires, Balloons..... in.	29x4.40
Pneumatic Tires, Extra..... in.	30x5	36x8
Tread..... in.	32	35	56
Width Overall..... in.	44	46	68
Weight..... lbs.	395	735	305

Models C-1 and C-3 have Timken taper roller bearings; Model 1369 has New Departure bearings.

TRAILERS

GRAYBAR CABLE REEL TRAILERS

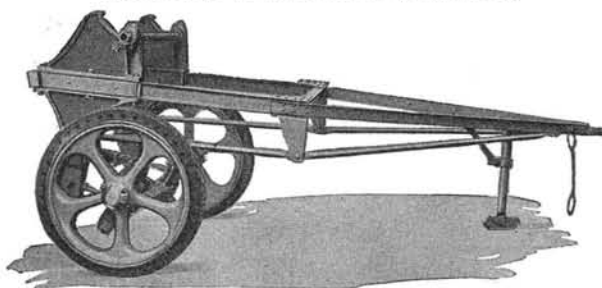

The Model D Cable Reel Trailer affords a means of quickly transporting reels of cable. It has the low center of gravity which is essential to safe transportation of heavy objects at high speed. When the trailer is uncoupled from the truck, the cable can be paid out from the reel without unloading from the trailer.

Specifications		D	WD-1	WD-2
Model.....		D	WD-1	WD-2
Capacity.....	tons	3	3	3
Size of Reel Handled.....		34"x7'	38"x7'	48"x7'
Diameter of Reel Spindle.....	in.	2½	2½	2½
Tread.....	in.	64	68	78
Tires, Solids.....	in.	36x5	36x7	36x8
Width of Bolster.....	in.	68	72	82
Width Overall.....	in.	79	83	93
Size of Axle.....	in.	2¾x2¾	2¾x2¾	2¾x2¾
Weight.....	lbs.	2250	2330	2385

This unit has electric steel spoke wheels of integral hub type, Timken roller bearings, and special heat treated chrome vanadium steel springs. All castings are electric steel cast. Axle material is 40-45 carbon steel, especially heat treated. The main frame and cross member is a 4-inch, 9½-pound I-beam.

GRAYBAR COMBINATION CABLE REEL AND POLE TRAILERS

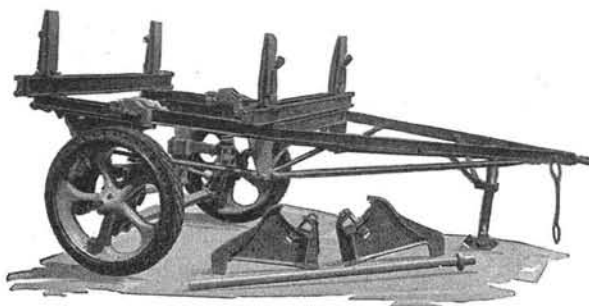

This trailer, as the name indicates, is one which can be used for hauling poles at one time and by making a changeover, it can be used for hauling cable reels. Through this combination there are really two trailers purchased at 50 per cent less than would have to be paid for separate cable reel and pole trailers.

Specifications		CP	WCP-1	WCP-2
Model.....		CP	WCP-1	WCP-2
Capacity.....	tons	3	3	3
Size of Reel Handled.....		34"x7'	38"x7'	48"x7'
Diameter of Reel Spindle.....	in.	2½	2½	2½
Tread.....	in.	64	68	78
Tires, Solids.....	in.	36x5	36x7	36x8
Width of Bolster.....	in.	68	72	82
Width Overall.....	in.	79	83	93
Size of Axle.....	in.	2¾x2¾	2¾x2¾	2¾x2¾
Weight.....	lbs.	2490	2590	2960

This unit has electric steel spoke wheels of integral hub type, Timken roller bearings, and special heat treated chrome vanadium steel springs. All castings are electric steel cast. Axle material is 40-45 carbon steel, especially heat treated. The main frame and cross member is 4-inch, 9½-pound I-beam.

All trailers furnished complete with one set of pole hauling bolsters and one set of cable reel saddles.

CONSTRUCTION MATERIAL

GRAYBAR SURE-BINDERS

A winch and ratchet arrangement with a 1-piece cast steel base which carries the pawl, lever and ratchet winch drum. The base fits over a pole and has two heavy spurs which cut into the pole when tension is put on, thus holding the binder firmly in place.

The binder is equipped with 18½ feet of 5/16-inch trulay plow steel wire rope breaking strength, 5,000 pounds.

Weight complete, 18½ pounds.

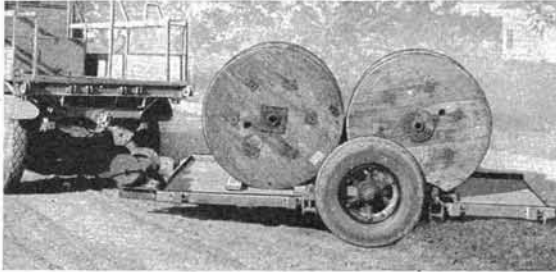
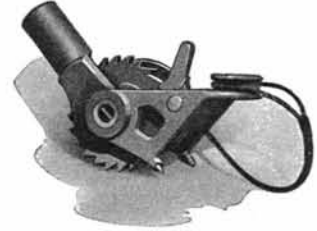

GRAYBAR LOWBED TRAILERS

The heavily constructed frame of the Low-Bed Trailer is made of angle and channel steel, electrically welded and riveted. The cross members are steel. The trailing eye can be adjusted from 17 to 34 inches from the ground, making the trailer usable with trucks, tractors, or pleasure cars.

Specifications

Model	Cap. Tons	Axle Clearance Inches	Platform, Inches			Height Loaded	Oak Inches
			Length	Width	Height Empty		
2-Lo-4	2	4	108	60	12	10	1 1/8
2-Lo-7	2	7	108	60	15	13	1 1/8
3-Lo-4	3	4	144	65	12	10	1 1/8
3-Lo-7	3	7	144	65	15	13	1 1/8
5-Lo-4	5	4	168	64	12	10	1 1/2
5-Lo-7	5	7	168	64	15	13	1 1/2
Trailer, Capacity.....			tons		2	3	5
Length Overall.....			in.		138	174	198
Width Overall.....			in.		91	95	96
Semi-Elliptic Springs.....			leaves		11	14	14
Size Springs.....			in.		2 1/2 x 3 3/8 x 50	2 1/2 x 3 3/8 x 45	3 x 3 3/8 x 45
Tires, Solids.....			in.		32x3	36x5, 36x6	36x7, 36x8
Tires, High Pressure.....			in.		32x6	36x8	38x9
Tires, Balloon.....			in.		7.50-20	9.00-20	11.25-20
Weight.....			lbs.		1500	1900	2500

Wheel spindle is 2½ inches round heat treated. Lower axle is 3 inches square, hollow. Dayton steel hollow spoke wheels, with Timken taper roller bearings.

A 4-inch double channel tongue, with trailer eye of chrome nickel steel casting. Stake pockets are standard equipment.

Optional Equipment

Stake racks of hardwood construction, securely bolted, furnished in heights of 3 to 5 feet.

Stakes only, of select straight grain hardwood, furnished in heights of 3 or 5 feet (10 stakes required per set).

All steel hand winch; two speeds, 4 to 1 and 24 to 1. Capacity, 5-ton straight line pull. Drum capacity, 160 feet, 5/8-inch cable; 250 feet, 1/2-inch cable; 325 feet, 1/16-inch cable. Size, 16x17x13 inches. Positive internal brakes. Installed on front of trailer. Easily detached.

PINTLE HOOKS

The Model B Pintle Hook has positive locking arrangement, preventing the eye of the hook from opening when trailing. The hook is always kept in perpendicular position. Complete assembly weighs approximately 65 pounds.

The Model 1417 is used on trucks up to 3½-ton capacity. Long braces are attached to frame side members. The latch is of the positive lock type.

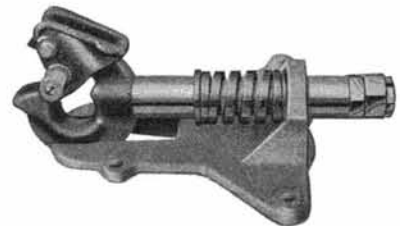

CONSTRUCTION MATERIAL

NO. 324 SIMPLEX AERIAL CABLE JACK AND SLACK PULLER



Designed for pulling both overhead and underground power and telephone cables. Also for taking up slack in guy wires.

Made from the best grade of steels and all parts

are heat-treated and hardened. Single acting and automatic operation.

No.....	324
Capacity.....	4000 pounds
Travel.....	20 inches
Weight, Complete with Handle.....	14 pounds

GRAYBAR CABLE SPLICER'S CARTS

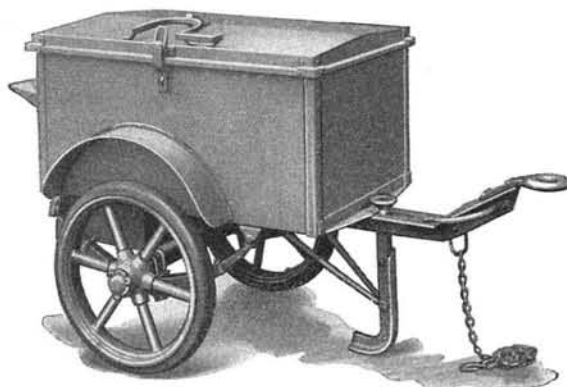
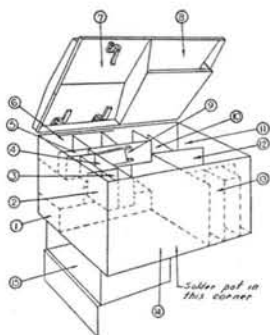

This is an all steel, compact, moveable workshop. While parked, the cart is kept in a rigid, horizontal position by a support which folds up beneath the body of the cart; while traveling. The underslung spring construction eliminates sluing and tipping at high speeds. Other features are the drop forged pintle hook, a 7-foot length of safety chain and convenient hand grips for use in moving the trailer about by hand.

Contents consist of:

1. Solder, paraffin dipper, test set, condenser, wooden cable dresser.
2. First aid kit.
3. Lashing wire and paster box.
4. Shave hook, furnace wrench, sleeve punches, drill holder, iron cable dresser 216-B tool, steel figures, chipping knife, furnace cleaner, pliers, test pick, test point.
5. Small materials.
6. Cotton sleeving, cotton tape, stearine, rubber bandages, hand test set, test cords, splicer's mirror and muslin.
7. Furnace shield.
8. Splicer's personal effects and specifications.
9. Cable saw.
10. Manhole shovel, solder ladle.
11. Kerosene can.
12. Kerosene furnace.
13. File, rasp, drills, soldering coppers, screw driver, wrench, hammers, paraffin thermometer.
14. All other tools and materials.
15. Tarpaulins and paraffin.

Specifications

Capacity, 1000 pounds.
 Length overall, 74 inches; height overall, 41 inches.
 Size of axle, 1 1/4 inches square; clearance, 11 1/4 inches.
 Springs, 7 leaves, 32x1 1/2 inches.
 Tires, 24x3 inches, solid. Tread, 34 inches.
 Electric steel spoke wheels with Timken roller bearings.
 Length of safety chain, 84 inches.
 Size of tool box, 42 1/4 inches long, 22 inches high, and 27 inches wide. Lower compartment is 14 1/2 inches long, 7 inches high, and 20 inches wide.
 Weight, 480 pounds.

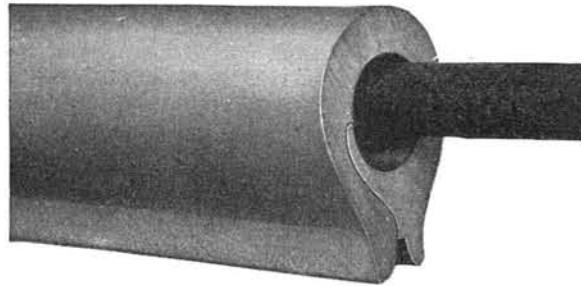
CONSTRUCTION MATERIAL**SALISBURY LINE HOSE**

A convenient device for protecting linemen from accidental contact with energized lines. By completely surrounding the wire with a substantial wall of voltage resisting rubber more than ample insulation is provided.

Made of high grade, clean, fresh crude rubber, combined with the proper non-metallic materials which give high dielectric strength, toughness, durability and long age.

The self-locking lip prevents the hose from being accidentally detached. Short bends can be made without exposing the conductor it covers.

Its flexibility makes its use adaptable to various conditions of service. Readily follows the bends of taps, jumpers or leads.

Simple to place, slides on wire from either above or below. Can be removed easily. Being relatively small in diameter, light and complete, it is conveniently transported, raised and handled aloft.

Most companies have adopted the 1-inch diameter size as standard as it will cover practically all lines in distribution service. The $\frac{1}{4}$ and $\frac{3}{8}$ -inch sizes are used by telephone and telegraph companies where lines run parallel to high tension power lines and are in danger of becoming energized to a high voltage by induction.

Furnished in $\frac{1}{4}$, $\frac{3}{8}$, $\frac{5}{8}$, 1, $1\frac{1}{4}$ and $1\frac{1}{2}$ -inch sizes, inside diameter; in standard lengths of 3, $4\frac{1}{2}$ and 6-foot pieces.

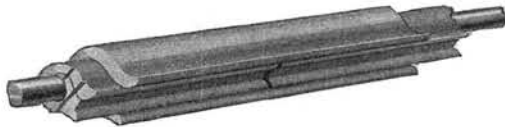
SALISBURY LINE HOSE CONNECTORS

For use where two or more pieces of line hose are employed on one wire. Prevents the hose from slipping apart and thereby eliminates the possibility of the conductor being exposed between the adjoining ends.

Shaped to snugly fit the outside contour of the hose. Walls are of extra thickness to provide

the necessary grip. A series of ribs, designed to grip the hose, are placed on the inside surface to give connector a tight hold.

Made in 2 sizes to fit over $\frac{5}{8}$ or 1-inch line hose.

In ordering specify hose size.

SALISBURY LINEMEN'S GLOVE BAGS

Used to protect linemen's rubber gloves when not in use. Made of heavy, tightly woven, waterproof 42-ounce white duck with non-raveling edges.

Special features: Snap back and D ring for attaching to belt; double head reinforcing rivets; sewed with linen thread, lock stitched; gusset sides and bottom, carrier flat when empty; flat lying cover; strong snap fastener; waterproof; ventilating eyelets in bottom gusset.

No.....	35	25
Length..... inches	15	9
Width..... inches	8	8



CONSTRUCTION TOOLS

SALISBURY STEAM CURED LINEMEN'S RUBBER GLOVES

With the realization that rubber gloves are the most important article in a lineman's equipment and that strength and durability are imperative for safety, Salisbury's Gloves are most conscientiously made.

Only the best materials are used and all operations from mixing to final inspection are carefully conducted. Investigation and experiment in laboratory, factory and field are constantly made to discover possible improvements in either material or manufacturing operations.

Qualities of high insulation, low leakage, strength, flexibility and long life are evenly balanced. Each of these essentials is raised to the highest possible value without lowering the standard of some other property.

To satisfy all demands, Salisbury's Gloves are furnished in either the No. 90 standard straight finger or the No. 100 curved finger styles. Both types are furnished in 10000, 15000 and 20000-volt ratings. There is also a choice of gloves that are vulcanized by either the steam or acid process.

All gloves are seamless, form fitting, accurate to size, with finger lengths and widths adjusted to best meet average conditions.

Salisbury Rubber Gloves are guaranteed to pass the most thorough inspection and to meet the A.S.T.M. and N.E.L.A. specifications.

Replacement will be made, or return accepted, of all gloves which fail under initial tests at their rated voltage or otherwise prove unsatisfactory at the time of delivery.

Class B—10000-volt, 14-inch gloves are standard.

Class A—10000-volt, heavier weight gloves are available.

Furnished in sizes 9, 9½, 10, 10½, 11 and 12.

Packed one pair to a box.



No. 90
Straight Finger Style



No. 100
Curved Finger Style

SALISBURY RUBBER PROTECTIVE BLANKETS

Particularly useful in covering secondary racks, dead ends, cut-outs, pot heads, arresters, and similar equipment. Also useful in station and underground work.

Will fold, wrap or hang suspended in any position to provide an insulating barrier between electrical workers and hazards adjacent to their working position.

Bead molded on all four sides to prevent tearing.

Duck Inserted—Black

Recommended for hardest service conditions. Has ample flexibility. Guaranteed on acceptance tests to resist 20000 volts for 3 minutes.

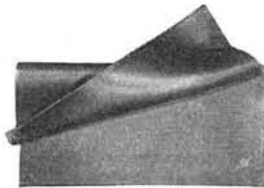

No.	Plain	Size, Inches	No.	With Eyelets	Size, Inches
100		36x36x 1/8	100-E		36x36x 1/8
200		27x36x 1/8	200-E		27x36x 1/8

All Rubber—Black

More pliable than the duck inserted type. Guaranteed on acceptance tests to resist 20000 volts for 3 minutes.

No.	Plain	Size, Inches	No.	With Eyelets	Size, Inches
300		36x36x 1/8	300-E		36x36x 1/8
400		27x36x 1/8	400-E		27x36x 1/8

Pure Gum Center—Maroon

For classes of work requiring extreme flexibility and lightness in weight. Desirable for close wrap around work. Guaranteed on acceptance tests to resist 30000 volts for 3 minutes.

No.	Plain	Size, Inches	No.	With Eyelets	Size, Inches
500		36x36x 1/8	500-E		36x36x 1/8
600		27x36x 1/8	600-E		27x36x 1/8

JACKS

SIMPLEX CABLE REEL JACKS

Automatic Lowering

Nos. 320 and 321 are recommended for warehouse service in handling cable, wire rope and belting reels. No. 320 is single acting for reels from 20 to 60 inches in diameter. No. 321 is single acting for reels from 20 to 96 inches in diameter.

No. 322 is generally used for heavy outdoor service. It is double acting for cable reels ranging from 36 to 84 inches in diameter. The T-shaped base provides a firm foundation. Furnished in pairs, one right and one left hand, for uniform operation on each side of the reel.

These jacks are furnished with steel lever bars.



No. 321



No. 322

Capacity.....	tons	5	10	10
Height.....	inches	21	34½	29
Lift.....	inches	11	14½	14
Weight.....	pounds	46	108	104

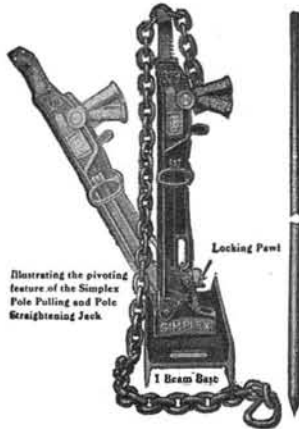

Illustrating the pivoting feature of the Simplex Pole Pulling and Pole Straightening Jack

NO. 329 SIMPLEX POLE PULLING JACKS

Single acting; automatic in raising and lowering, will not trip. For pulling and straightening telephone, telegraph, electric light and trolley poles any depth in the ground without digging around them.

With 8-foot steel chain, 5-foot steel pinch bar and steel I-beam base.

No.....		329
Capacity.....	tons	15
Height.....	inches	37½
Lift.....	inches	21
Wt., Complete.....	pounds	193

SIMPLEX SCREW TYPE CABLE REEL JACKS

Jacks will handle any standard weight reel with the use of the 3-way nuts.

No. 1 Jack handles reels from 42 to 60 inches in diameter; No. 2 handles reels from 60 to 90 inches in diameter.

Size of screw, 1⅞ inches in diameter.

No.....	1	2
Minimum Height, Bearing Point.....	inches 19⅝	29¾
Maximum Height, Bearing Point.....	inches 31⅝	46¼
Lift.....	inches 11½	16½
Length Base.....	inches 26	39½
Width Base.....	inches 12	15½
Weight.....	pounds 51	89

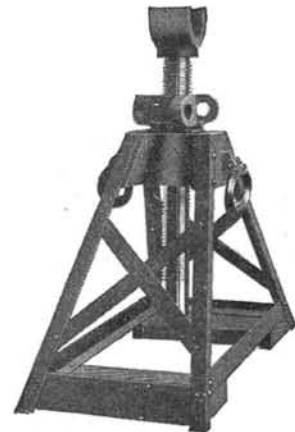

JACKS

SIMPLEX PORTABLE CABLE REEL JACKS



No. 41



No. 81

Jack held on oak base by taper wedged brackets—can be quickly removed and packed in tool box. Made single acting, raising the load on the downward stroke only, and double acting, raising the load on both the downward and upward strokes.

Designed to lift small, but heavy cable reels from 24 inches to 48 inches diameter, and can readily be used for any work, where 1 to 2-ton loads are to be handled.

Cat. No.....	Double Acting			Single Acting			
	41	42	43	81	82	83	84
Capacity..... tons	1	1½	2	1	1½	2	5
Lift..... inches	8	9½	11	7	8½	9¾	7½
Height..... inches	11½	13¼	14½	11¾	13¼	14¾	16
Total Height..... inches	19½	22¾	25½	18¾	21¾	24½	23½
Weight with Base..... pounds	15½	18	19	17½	18½	19½	35

NO. 325 SIMPLEX POLE JACKS

A combination pushing and pulling jack. Light and sturdy. Furnished with pike pole, steel chains, detachable base and steel lever pole.

No.....	325
Capacity..... tons	5
Height..... inches	48
Lift..... inches	36
Weight, without Equipment..... lbs.	33
Weight, with Equipment..... lbs.	100

CONSTRUCTION TOOLS

NO. 10 OSHKOSH PIKE POLE GUARDS



For guarding the hazardous point on pike poles.

The guard works easily and fastens securely in either the guarded or open position. When in the unguarded position, the guard is completely out of the way, snugly fitted around the pole. When in the guarded position, it automatically locks in place and provides complete protection from the pike point.

This guard will fit either the 2-inch or 2½-inch pike poles. It is light in weight, adding only 7 ounces to the pike pole.

Shipping weight, 7 ounces.

CONSTRUCTION TOOLS

OSHKOSK GUARDED PIKE POLES



Handles of soft, old growth yellow Washington Fir, straight grained, and free from defects. The forks are malleable iron with the fork and socket cast in one piece.

Cat. No.	Size In. x Ft.	Wt. Lbs. Each	Cat. No.	Size In. x Ft.	Wt. Lbs. Each
832	2 x 10	10	797	2½ x 14	14
833	2 x 12	12	835	2½ x 16	15
834	2 x 14	13	836	2½ x 18	16
795	2 x 16	15	837	2½ x 20	18
796	2½ x 12	13			

OSHKOSH MULE PATTERN WOOD POLE SUPPORTS



Made of Washington Fir tapering slightly at both ends. Forged steel fork and pick, banded at each end with steel bands.

Cat. No.	Size Feet	Diam. at Ctr., In.	Wt. Lbs. Each	Cat. No.	Size Feet	Diam. at Ctr., In.	Wt. Lbs. Each
845	6	3½	23	847	8	4½	29
846	7	4	26

NO. 848 OSHKOSH STANDARD DEADMAN WOOD POLE SUPPORTS



Made of select rock maple. Heavy wrought steel fork and pike banded at both ends with steel.

Cat. No.	Size Feet	Size of Wood, In.	Wt. Lbs. Each
848	8	4 x 2	29

OSHKOSH JENNEY PATTERN WOOD POLE SUPPORTS

Made of Washington Fir with forged steel fork. Steel pikes are placed in the bottom to prevent it from slipping on hard ground. This support is collapsible and has steel bushed holes where there is any wear. A light, strong, safe, pole support.



Cat. No.	Size Feet	Size of Wood, In.	Wt. Lbs. Each
842	6	1¾ x 3	25
843	7	1¾ x 3½	30
844	8	1¾ x 3½	35

OSHKOSH MALLEABLE CLASP CANT HOOKS



Hooks are hammer forged from crucible steel and have heavy upset points. Clasp and toe ring are made of best grade malleable iron. Handles of select hard rock maple and second growth hickory.

Select Maple Handles

Cat. No.	Size In. x Ft.	Wt. Lbs. Each
188A	2¼ x 4	7
189A	2¼ x 4½	8
188	2½ x 4	8
189	2½ x 4½	8½

Select Hickory Handles

Cat. No.	Size In. x Ft.	Wt. Lbs. Each
199A	2¼ x 4	7
200A	2¼ x 4½	8
199	2½ x 4	8
200	2½ x 4½	9

CONSTRUCTION TOOLS

OSHKOSH MALLEABLE SOLID SOCKET PEAVIES



Light, strong, durable and evenly balanced. Socket is made from the best grade of malleable iron. The hook and pick are made of crucible steel, pick and socket are set in oil, under screw pressure, not burnt or driven in.

Regular Maple Handles

Cat. No.	Size In. x Ft.	Wt. Lbs. Each
121	2 1/4 x 4	7
122	2 1/4 x 4 1/2	7
124	2 1/2 x 4	9
125	2 1/2 x 4 1/2	9

Select Hickory Handles

Cat. No.	Size In. x Ft.	Wt. Lbs. Each
134	2 1/4 x 4	8
135	2 1/4 x 4 1/2	8
137	2 1/2 x 4	9
138	2 1/2 x 4 1/2	10

OSHKOSH CARRYING OR LUG HOOKS

For handling poles and heavy timbers. Made with crucible steel chisel point hooks, and malleable iron clasps and swivels. Handles of selected hard rock maple.



Regular Pattern

Cat. No.	Size In. x Ft.	Wt. Lbs. Each	Cat. No.	Size In. x Ft.	Wt. Lbs. Each
295	2 1/2 x 4	7	297	2 1/2 x 5	8
296	2 1/2 x 4 1/2	8

Extra Heavy, with Steel Swivels

Cat. No.	Size In. x Ft.	Wt. Lbs. Each	Cat. No.	Size In. x Ft.	Wt. Lbs. Each
298	3 x 5	12	300	3 x 7	14
299	3 x 6	13

NO. 740 OSHKOSH FIR DEADMAN WOOD POLE SUPPORTS



Of clear, straight grained fir. Measures 3 x 3 inches square, 8 1/2 feet over all. Steel fork has three prongs.

No.	Wt. Lbs. Each	Each
740	40	\$16.95

WOOD HANDLES FOR CANT HOOKS



Maple Handles

Cat. No.	Diameter Inches	Length Feet	Weight Pounds Each
541	2 1/4	4	3
542	2 1/4	4 1/2	3
544	2 1/2	4	3
545	2 1/2	4 1/2	4

Hickory Handles

Cat. No.	Diameter Inches	Length Feet	Weight Pounds Each
572	2 1/4	4	3
573	2 1/4	4 1/2	3
575	2 1/2	4	4
576	2 1/2	4 1/2	4

OSHKOSH SPECIAL PIKE POLE COATING

Oshkosh Pike Poles finished with this specially developed coating prevent loss of time caused by splinters and splinters.

- It gives a smooth, hard, transparent coating.
- This coating keeps the grain from raising.
- It is a non-conductor of electricity.
- Can be applied at a slight additional charge.

CONSTRUCTION TOOLS

OSHKOSH WESTERN PATTERN POST HOLE SPOONS



With Carbon Steel Blade

Maple Handles				Extra Handles		*Ash or Hickory Handles					
Cat. No.	Handle Feet	Strap Inches	Weight Pounds	Cat. No.	Wt. Lbs.	Cat. No.	Handle Feet	Strap Inches	Weight Pounds	Extra Handles Cat. No.	Wt. Lbs.
859	7	22	10	993	4	1023	7	22	10	1005	6
860	8	22	10	994	5	1024	8	22	10	1006	6
861	9	22	11	995	6	1025	9	22	11	1007	7
862	10	22	11	996	7	1026	10	22	12	1008	7
						1027	12	22	14	1009	8

With Alloy Steel Blade

*Ash or Hickory Handles				—Extra Handles—	
Cat. No.	Handle Feet	Strap Inches	Weight Pounds	Cat. No.	Wt. Lbs.
2023	7	22	10	2005	6
2024	8	22	10	2006	6
2025	9	22	11	2007	7
2026	10	22	12	2008	7
2027	12	22	14	2009	8

* For hickory handles, add letter H to Cat. No.

OSHKOSH EASTERN PATTERN POST-HOLE SPOONS



With Carbon Steel Blade

Maple Handles				Extra Handles		* Ash or Hickory Handles					
Cat. No.	Handle Feet	Strap Inches	Weight Pounds	Cat. No.	Wt. Lbs.	Cat. No.	Handle Feet	Strap Inches	Weight Pounds	Extra Handles Cat. No.	Wt. Lbs.
859E	7	22	10	993	4	1023E	7	22	10	1005	6
860E	8	22	10	994	5	1024E	8	22	10	1006	6
861E	9	22	11	995	6	1025E	9	22	11	1007	7
862E	10	22	11	996	7	1026E	10	22	12	1008	7
						1027E	12	22	14	1009	8

With Alloy Steel Blade

* Ash or Hickory Handles				—Extra Handles—	
Cat. No.	Handle Feet	Strap Inches	Weight Pounds	Cat. No.	Wt. Lbs.
2023E	7	22	10	2005	6
2024E	8	22	10	2006	6
2025E	9	22	11	2007	7
2026E	10	22	12	2008	7
2027E	12	22	14	2009	8

* For hickory handle, add letter H to Cat. No.

OSHKOSH STRAIGHT HANDLE SHOVELS

Handles are extra large in diameter, measuring $1\frac{3}{16}$ inches.

With Carbon Steel Blade

Maple Handles				Extra Handles		* Ash or Hickory Handles					
Cat. No.	Handle Feet	Strap Inches	Weight Pounds	Cat. No.	Wt. Lbs.	Cat. No.	Handle Feet	Strap Inches	Weight Pounds	Extra Handles Cat. No.	Wt. Lbs.
867	7	22	8	993	4	1032	7	22	8	1005	6
868	8	22	9	994	5	1033	8	22	9	1006	6
869	9	22	10	995	6	1034	9	22	10	1007	7
870	10	22	11	996	7	1035	10	22	11	1008	7

With Alloy Steel Blade

* Ash or Hickory Handles				—Extra Handles—	
Cat. No.	Handle Feet	Strap Inches	Weight Pounds	Cat. No.	Wt. Lbs.
2032	7	22	8	2005	6
2033	8	22	9	2006	6
2034	9	22	10	2007	7
2035	10	22	11	2008	7

* For hickory handle, add letter H to Cat. No.

CONSTRUCTION TOOLS



OSHKOSH D-HANDLED SHOVELS

With Carbon Steel Blade

The handle is second growth Northern white ash and is fitted with a pressed steel D top.

Cat. No.	Style of Blade	Wt. Lbs.	Extra Handles Cat. No.	Wt. Lbs.
1092R	Round Point	4	1093	2
1092S	Square Point	4	1093	2

With Alloy Steel Blade

The handle is of clear straight grained ash, sharply bent, and fitted with a steel D top.

Cat. No.	Style of Blade	Wt. Lbs.	Extra Handles Cat. No.	Wt. Lbs.
2092R	Round Point	4	2093	2
2092S	Square Point	4	2093	2

OSHKOSH CROW AND DIGGING BARS



Made of special octagon crucible steel, exceedingly tough and stiff.

Cat. No.	Size Inches x Feet	Weight Pounds Each	Cat. No.	Size Inches x Feet	Weight Pounds Each
1061	1 x 7	20	1064	1 1/8 x 7	26
1062	1 x 8	23	1065	1 1/8 x 8	30

OSHKOSH TAMPING AND DIGGING BARS



Made of special octagon crucible steel, tough and stiff.

Cat. No.	Size Inches x Feet	Weight Pounds Each	Cat. No.	Size Inches x Feet	Weight Pounds Each
1071	1 x 7	20	1074	1 1/8 x 7	26
1072	1 x 8	23	1075	1 1/8 x 8	30

OSHKOSH PLAIN DIGGING BARS



Made of special octagon crucible steel, tough and stiff.

Cat. No.	Size Inches x Feet	Weight Pounds Each	Cat. No.	Size Inches x Feet	Weight Pounds Each
1081	1 x 7	19	1084	1 1/8 x 7	24
1082	1 x 8	21	1085	1 1/8 x 8	28

NO. 852 OSHKOSH DIGGING SPUDS WITH TAMPER



A light, evenly balanced digging tool. Handle is made of steel tubing with a tamping head of malleable iron, and the blade and socket are of one piece of forged high carbon steel.

Cat. No.	Size Feet	Wt. Lbs. Each
852	9	20

NO. 853 OSHKOSH LOYS OR SLICKS



The handle is of 2-inch selected maple and the blade is of tool steel 4 x 1/2 inches, burned onto the handle and held by two large rivets.

Length, eight feet. Weight, 18 pounds each.

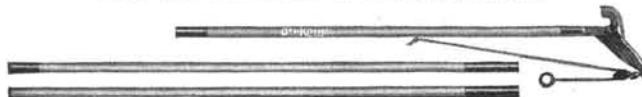
CONSTRUCTION TOOLS**NO. 915 OSHKOSH TREE TRIMMERS**

The Oshkosh Tree Trimmer is light and strong.

The head is made of two pieces of light forged steel reinforced and riveted together. These sides act as a guide for the thin saw steel cutting blade.

The blade is pivoted and starts cutting with a slicing motion the moment the rope is pulled. It cuts limbs up to 1½ inches in diameter.

The handle is made in three sections of 1½-inch straight grained, clear Washington Fir. One 6-foot section is attached to head, and two 7-foot lengths equipped with positive couplings of rigid construction, yet easily dismantled.

Furnished complete with handle and short section of rope.

No. 915, Trimmer, Complete, weight, 13 pounds.

No. 915B, Blade, weight, 10 ounces.

No. 915S, Spring, weight, 2 ounces.

No. 915EM, Middle Extension, weight, 4 pounds.

No. 915EE, End Extension, weight, 4 pounds.

No. 915R, 20 Feet of Rope, weight, ¼ pound.

NO. 916 OSHKOSH TREE SAWS

The saw blade is a strong, thin, fine tooth blade. It cuts fast and clean and leaves a good smooth cut.

The steel frame has a hook for hanging saw in tree or pulling cut branches out that have caught. The 6-foot handle has a ferrule on bottom to which can be connected the regular extensions of the Oshkosh Tree Trimmer.

No. 916, Tree Saw, weight, 5 pounds.

No. 916B, Saw Blade, weight, ¼ pound.

No. 916T, Saw Tightener, weight, ¼ pound.

OSHKOSH FOLDING TAKE-UP REELS

The reel part collapses and automatically throws off the coil at the same time and in an instant is ready for another coil. The frame, made of heavy hardwood, is strong and heavily reinforced throughout and folds up like a hinge.

It can be taken down in a moment, merely pulling the pin out of the shaft, throwing off the coil and folding up the frame. Take up 21 inches, weight 41 pounds.

**OSHKOSH BARROW REELS**

Made of hard rock maple strongly reinforced with angle iron braces. Rests on strong steel legs. Has a large diameter pivot and is made for heavy work.

Cat. No.	Description	Wt. Lbs. Each
900	Barrow Reel Only	80
901	Extra Pins, per Set of 4	4

OSHKOSH PAY-OUT REELS

Made of hard maple, well constructed and reinforced throughout.

Cat. No.	Wt. Lbs. Each
902	40

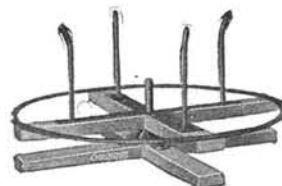

CONSTRUCTION TOOLS

NO. 920 OSHKOSH BRUSH HOOKS



For clearing right of ways for power lines or for clearing land of brush. It takes the place of an axe and scythe. It cuts small seedlings, bushes, and small trees easily.

Made of a crucible steel particularly suitable for this tool. The eye or socket is securely welded to blade. The back strap eliminates the necessity of wedging the handle in the eye and holds the handle to the blade tightly. The handle is a high quality axe handle.

Weight, 4½ pounds.

OSHKOSH SAFETY EXTENSION LADDERS

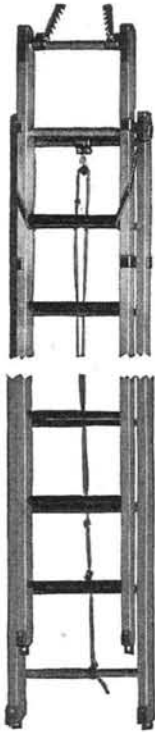

A light weight, safety extension ladder designed expressly for public utilities.

Equipped with an automatic safety lock or latch. This lock is so arranged that when pulling on the raising rope, the lock is lifted out of position. The instant the strain on the rope is slackened, the lock drops in place. In lowering, the extension must be lowered slowly. It cannot accidentally drop.

The side rails are made from straight grained, properly seasoned aeroplane spruce.

The rungs are made from tough mountain hickory, straight grained. Each rung has a shouldered tenon joint which is pressed tightly into the side rails, assuring a safe, tight fit. The side rails of each section are connected at top, middle, and bottom with steel tie-rods. This combination makes a rugged, durable construction. Either section can be used separately as an individual ladder, both being equipped with safety tips and pikes.

Other safety features include rubber faced tips, transparent safety finish, safety pole-grippers, and rubber guarded safety pikes. All metal parts are parkerized.

Furnished in full range of lengths.

Weight, 2 pounds per foot, average.

OSHKOSH WARNING SIGNS

This warning sign is light in weight, yet durable. Legs are of ½-inch high carbon steel. Has ¼-inch flange around edge of lettered side.

Has two hollow handles for adjusting angle of the legs. These handles also serve as flag sockets, and each is equipped with a lantern lock.

Black letters, 5½ inches high, on traffic yellow background.

- Height, 43 inches.
- Width, 28 inches.
- Thickness, 1¼ inches.
- Size folded, 28x28x1¼ inches.
- Weight, 23 pounds.



OSHKOSH METAL FLAGS

This metal flag is light and strong. It is made of 16-gauge steel welded to a 5/8-inch hollow iron staff. The flag is painted bright red and the staff black. The little peg hole near the top is for conveniently hanging it up in the truck.

The Oshkosh Warning Sign and the Oshkosh Folding Barricade have handy sockets to accommodate this flag.

- Staff, 20 inches high.
- Size of flag, 12x10 inches.

CONSTRUCTION MATERIAL

MANHOLE GUARDS



Open, 50 x 50 x 42 in.; closed, 3½ x 50 x 42 in.
Shipping weight, 43 lbs.

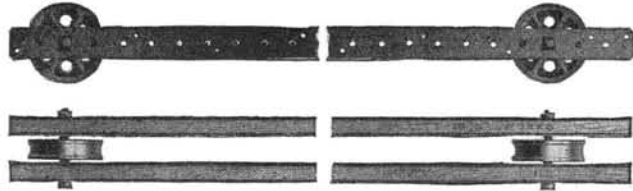

MANHOLE SKIDS AND SHEAVES

Standard length 9 feet.



MANHOLE FRAMES AND COVERS

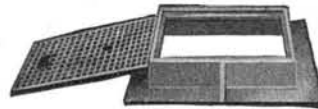

Square

Cat. No.	Size, Inches		Ht. In.	Wt. Lbs. Each
	Opening	Flange		
229	17 x 22	31 x 36	6	340
271	18 x 30	26 x 38	5	375
278	28 x 32	38 x 42	7¼	620

Round

202	23	36	9	540
204	23	36	9	450
206	23	36	9	400
208	23	35	7	350
211	23	36	6	315
212	22	30	5¼	265

NO. 220 SIMPLEX MANHOLE SHEAVE

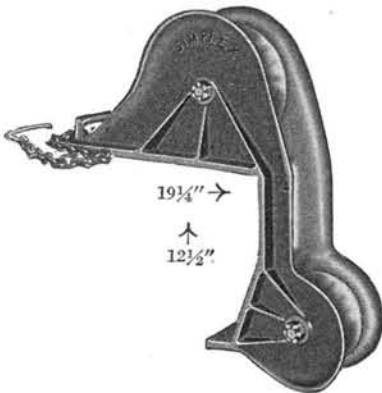

Specifications:

Frame—malleable iron.
Pulleys—malleable iron with bronze bushings.

Diameter Small Sheave.....	4¾"
Width Small Sheave.....	3"
Diameter Large Sheave.....	7¾"
Width Large Sheave.....	3"
Weight.....	96 lbs.

Furnished with ¼" dia. x 24" Chain with special hook for anchoring.

Finished with rounded channel and designed for handling and pulling cable up to 3" in diameter or carrying any size winch line at right angles.

For use on the end of a truck or over the top of manhole in connection with a snatch block in the manhole, eliminating the use of long, heavy manhole skids.

CONSTRUCTION TOOLS

DIAMOND MANHOLE COVER HOOKS



This is a useful tool for the subway construction force. It is designed to easily raise a heavy manhole cover by prying the wedged point end of the hook under the groove provided in the cover for the purpose.

The hook is made of an excellent quality of electric tool steel suitably hardened at and adjacent to the hook to prevent its bending, and at the same time sufficiently tough to prevent breaking off.

HUBBARD CABLE DUCT SHIELDS

Zinc and Hot Galvanized Steel

Used to protect cable sheaths at entrance of ducts. As cable expands and contracts the wear comes on the shield rather than on the lead sheath. May be installed, if desired, after the cable is pulled in.

Cat. No.	Material	Size, Inches		Std. Pkg.	Wt., Lbs. per 100
		Diam.	Length		
9140	20-Ga. Sheet Steel	3	6	100	61
9141	18-Ga. Zinc	3	6	100	58
9142	12-Ga. Sheet Steel	2 ⁵ / ₈	9	50	170



OSHKOSH FOLDING BARRICADES

The Oshkosh Folding Barricade is strong and substantial, easily and quickly set up.

The cross-rail is held like a piece of wood in a vise. This allows the use of wood from 1 to 3 inches in thickness. Not having any teeth, the jaws do not chew up the wood cross-rails.

It is easily and quickly taken down and folded into a small, compact bundle which stacks easily and safely.

The screw handle is made of pipe and forms a socket for holding a danger flag. The socket is 4 inches deep.

A lantern lock is welded to the screw handle of each barricade. The lock itself is a set screw which is screwed outward to release the lantern and screwed to lock the lantern.

Orange finish.

Size.....	inches	32	42
Height.....	inches	32	42
Width (Bottom Open).....	inches	20 ¹ / ₂ to 22 ³ / ₄	25 to 29
Size Folded.....	inches	3x2x35	3x2x44
Weigh.....	pounds	25	32



Folded

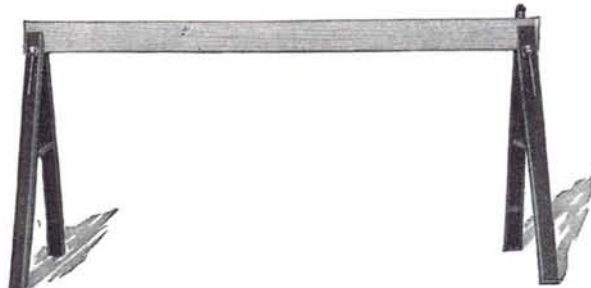

CONSTRUCTION TOOLS

B & L STAR BRAND PUBLIC UTILITY STAR METAL BLOCKS FOR MANILA RPOE

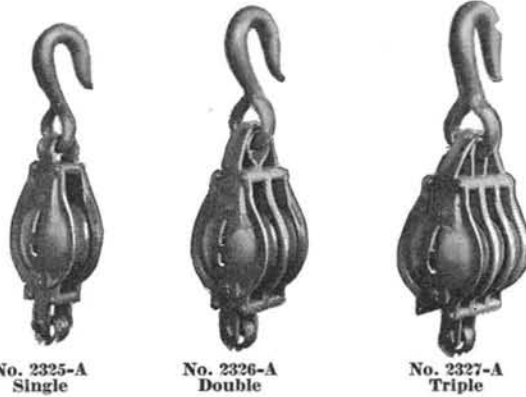

Malleable Iron Shells—Loose Side Hooks and Becketts

Hooks are drop-forged of special steel and of extra large size and strength. The shell is certified malleable iron—carefully rounded and without sharp projection and constructed to prevent rope jamming between the shell and sheaves.

Double blocks of all sizes have full center straps, and all straps extend through the entire length of the block so all becket strain is borne by the straps not the shell.

Pin ends are entirely covered by recess in sides of the shell, allowing the block to be used on the ground or to pass any protruding object, when raising or lowering without interference.

Sheaves are of standard tackle block dimensions, and can be supplied japanned or galvanized, with any style bushing.

Blocks can be supplied promptly in all sizes. Supplied with any connection, including safety link.

Sheaves in 8-inch blocks and smaller are same sizes as in regular mortise wood blocks. Sheaves in 9-inch blocks and larger are same sizes as in wide mortise wood blocks.

Iron Bushed Dimensions, Inches			Patent 6-Roller Bushed Dimensions, Inches			Graphite-Bronze Bushed Self-Lubricated Dimensions, Inches		
Size Sheaves	Diam. Rope	Length Shell	Size Sheaves	Diam. Rope	Length Shell	Size Sheaves	Diam. Rope	Length Shell
1 3/4 x 1/2 x 3/8	3/8	3	1 3/4 x 1/2 x 3/8	3/8	3	1 3/4 x 1/2 x 3/8	3/8	3
2 x 5/8 x 3/8	1/2	3 1/2	2 x 5/8 x 3/8	1/2	3 1/2	2 x 5/8 x 3/8	1/2	3 1/2
2 1/4 x 5/8 x 3/8	1/2	4	2 1/4 x 5/8 x 3/8	1/2	4	2 1/4 x 5/8 x 3/8	1/2	4
3 x 3/4 x 3/8	5/8	5	3 x 3/4 x 3/8	5/8	5	3 x 3/4 x 3/8	5/8	5
3 1/2 x 1 x 1/2	3/4	6	3 1/2 x 1 x 1/2	3/4	6	3 1/2 x 1 x 1/2	3/4	6
4 1/4 x 1 x 1/2	7/8	7	4 1/4 x 1 x 1/2	7/8	7	4 1/4 x 1 x 1/2	7/8	7
4 3/4 x 1 1/8 x 5/8	1	8	4 3/4 x 1 1/8 x 5/8	1	8	4 3/4 x 1 1/8 x 5/8	1	8
5 1/2 x 1 3/8 x 5/8	1 1/8	9	5 1/2 x 1 3/8 x 5/8	1 1/8	9	5 1/2 x 1 3/8 x 5/8	1 1/8	9
6 1/4 x 1 1/2 x 3/4	1 1/4	10	6 1/4 x 1 1/2 x 3/4	1 1/4	10	6 1/4 x 1 1/2 x 3/4	1 1/4	10
8 x 1 5/8 x 3/4	1 3/8	12	8 x 1 5/8 x 3/4	1 3/8	12	8 x 1 5/8 x 3/4	1 3/8	12
9 1/2 x 1 7/8 x 7/8	1 1/2	14	9 1/2 x 1 7/8 x 7/8	1 1/2	14	9 1/2 x 1 7/8 x 7/8	1 1/2	14

B & L STAR BRAND AERIAL CABLE GUIDE AND STRAIGHTENER

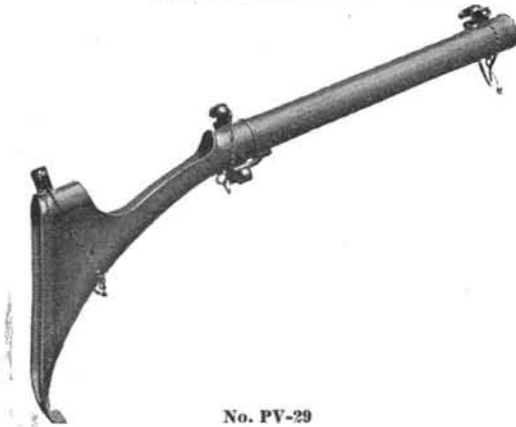

No. PV-29

For straightening lead covered cable while pulling into rings.

CONSTRUCTION MATERIAL

NO. 105-15 KLEIN'S SPLICING CLAMPS



Hammer forged from high grade crucible tool steel. Oil tempered, polished head and black handle.
Size, 8 inches.
Weight per dozen, 5 pounds.

A convenient pocket size clamp particularly adapted for telephone and telegraph repair work.

This clamp is arranged with openings for twisting double tube sleeves.

Copper sleeves Nos. 8, 10, 12, 14, 17, A.W.G.
Iron sleeves Nos. 10, 12, 14, 16, 19, B.W.G.

NO. 105-17 KLEIN'S SPLICING CLAMPS

The unusually wide range of sizes in this clamp makes it particularly valuable for general telephone and telegraph work.

This clamp has 5 sets of chambers for twisting double tube sleeves.

Copper sleeves Nos. 6, 8, 10, 12, 14, 17, A.W.G.
Iron sleeves Nos. 8, 10, 12, 14, 16, 19, B.W.G.

Hammer forged from high grade crucible tool steel. Oil tempered, polished head and black handles.
Size, 10 3/4 inches.
Weight per dozen, 15 pounds.



NO. 132-12 KLEIN'S COMBINATION WIRE AND SLEEVE CLAMPS



Hammer forged from high grade crucible tool steel. Oil tempered, polished head and black handles.
Weight per dozen, 10 pounds. Size, 9 inches.

For telephone and telegraph general line and trouble work.

This clamp has four round holes for twisting bare wire.

Copper wire Nos. 6, 8, 10, 12, A.W.G.

Iron wire Nos. 8, 10, 12, 14, B.W.G.

The reverse side has four double chambers for twisting sleeves.

NO. 132-15 KLEIN'S COMBINATION WIRE AND SLEEVE CLAMPS

The unusual range of wire and sleeve sizes covered by this clamp makes it practically a universal tool for telegraph, telephone and power line work. Has 5 round holes for twisting bare wire and an oval opening for guy wire or messenger strand. Copper wire Nos. 4, 6, 8, 10, 12, A.W.G.

Iron wire Nos. 6, 8, 10, 12, 14, B.W.G. Strand opening .437 x .624.

Reverse side has 5 chambers for twisting double tube sleeves. Copper sleeves Nos. 6, 8, 10, 12, 14, 17, A.W.G. Iron sleeves Nos. 8, 10, 12, 14, 16, 19, B.W.G.

Hammer forged from high grade crucible tool steel. Oil tempered, polished head and black handles.
Weight per dozen, 16 pounds. Size, 11 1/4 inches.



NO. 102-30 KLEIN'S SPLICING CLAMPS



Holes reversed for those who prefer this arrangement

Copper wire Nos. 2, 4, 6, 8, 10, 12 A.W.G.

Iron wire Nos. 4, 6, 8, 10, 12, 14, B.W.G.

No. 102-30, 10 3/4-inch. Wt. per Doz., 15 lbs.

NO. 132-46 KLEIN'S WIRE AND SLEEVE CLAMPS

One side for double tube copper sleeves Nos. 4, 6, 8, 10, and 12 A.W.G. Other side for copper wire Nos. 4, 6, 8, 10, and 12 A.W.G.

No. 132-46, Weight per Doz., 15 1/2 lbs.



CONSTRUCTION TOOLS

NO. 107 KLEIN'S DI-STOCK SLEEVE TWISTERS



Forged from high grade crucible steel. Has swing latch provided with thumb nut to fit over reverse jaw to hold both jaws securely in place.

Special prices on any combination upon application. Specify sizes of sleeve tool is intended for.

Tools are made to order only. Weight, 4 pounds.

This tool has ample leverage for use on heavy wires beyond the capacity of standard splicing clamps or connectors. The illustration above shows the Di-Stock fitted for making double tube joints.



Open to receive wire

NO. 132-47 KLEIN'S WIRE AND SLEEVE CLAMPS

For single tube or oval copper sleeves. Nos. 2, 4, 6, 8, and .104.

Hinge has stop to prevent handles from opening beyond point convenient for clamping on sleeve.

No. 132-47, Weight per Doz., 17 lbs.



NO. 105-31 KLEIN'S SPLICING CLAMPS

Three double chambers for twisting Nos. 10 and 12 A.W.G. sleeves, Nos. 12, 14, and 17 N.B.S. sleeves.

No. 105-31, 8 1/4-inch. Wt. per Doz., 10 lbs.

NO. 107-34 KLEIN'S DI-STOCK SLEEVE TWISTER

A hand operated cam lever closes the head securely on the sleeve—no thumb screws to bother with.

Tubular handles are furnished.

No. 107-34, weight each, 9 lbs.

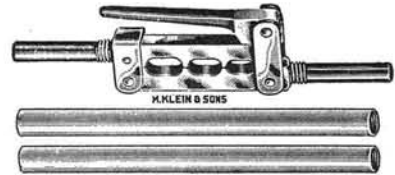

RELIABLE SINGLE EYE CABLE GRIPS

Soft Wire

Soft wire grips with soft eyes for attaching pulling line to the end of a cable. Soft eye slips easily through aerial rings.

36 inch length of body also standard.



Cat. No.	Size Inches	For Cable Diam. Inches	Cat. No.	Size Inches	For Cable Diam. Inches
822	3/4 x 18	3/4 to 7/8	832	3/4 x 24	3/4 to 7/8
823	1 x 18	1 to 1 3/8	833	1 x 24	1 to 1 3/8
824	1 1/2 x 18	1 1/2 to 1 7/8	834	1 1/2 x 24	1 1/2 to 1 7/8
825	2 x 18	2 to 2 3/8	835	2 x 24	2 to 2 3/8
826	2 1/2 x 18	2 1/2 to 2 7/8	836	2 1/2 x 24	2 1/2 to 2 7/8

RELIABLE DOUBLE EYE SPLIT CABLE GRIPS

Used for pulling slack in working cables. Can be attached and removed without cutting cables.



Cat. No.	Size Inches	For Cable Diam. Inches	Cat. No.	Size Inches	For Cable Diam. Inches
862	3/4 x 18	3/4 to 7/8	872	3/4 x 24	3/4 to 7/8
863	1 x 18	1 to 1 3/8	873	1 x 24	1 to 1 3/8
864	1 1/2 x 18	1 1/2 to 1 7/8	874	1 1/2 x 24	1 1/2 to 1 7/8
865	2 x 18	2 to 2 3/8	875	2 x 24	2 to 2 3/8
866	2 1/2 x 18	2 1/2 to 2 7/8	876	2 1/2 x 24	2 1/2 to 2 7/8
867	3 x 18	3 to 3 3/8	877	3 x 24	3 to 3 3/8
868	3 1/2 x 18	3 1/2 to 3 7/8	878	3 1/2 x 24	3 1/2 to 3 7/8

CONSTRUCTION TOOLS



KLEIN'S CHICAGO GRIPS

Main body piece and lever are forged steel. Draw parts are wrought steel. Gripping jaws are machined.

No. 1613 With Plain Jaw for Bare Wire

No.	Description	Max. Open. In.	Wt. Lbs. Each	No.	Description	Max. Open. In.	Wt. Lbs. Each
1613-30	For No. 6 Wire and Smaller.....	.2187	1 1/2	1613-40B	With Bronze Lined Jaws.	.3125	2 3/4
1613-30B	With Bronze Lined Jaws.	.1875	1 1/2	1613-50	For No. 0000 Wire and Smaller.....	.50	7 1/2
1613-40	For No. 0 Wire and Smaller	.3125	2 5/8	1613-50A	For No. 0000 Strand and Smaller.....	.625	7 1/2
1613-40A	For No. 0 Strand and Smaller.....	.375	2 5/8	1613-50B	With Bronze Lined Jaws.	.50	7 1/2

NO. 1628 KLEIN'S CHICAGO GRIPS

For Messenger Strand and Heavy Cables

Forged from alloy steel heat treated. Gripping jaws are machined smooth. Rivets are machine turned.

No.	For Strand	Safe Load	Max. Open In.	Wt. Lbs. Each
1628-5	2,200 to 10,000 Lbs.	6,000	7/16	5
1628-5B	With bronze lined jaws	6,000	.375	5
1628-6	2,200 to 6,000 Lbs.	8,000	13/32	8 1/2
1628-6B	With bronze lined jaws	8,000	.50	8 1/2
1628-16	10,000 to 16,000 Lbs.	15,000	1 1/16	14
1628-16B	With bronze lined jaws	15,000	.625	14

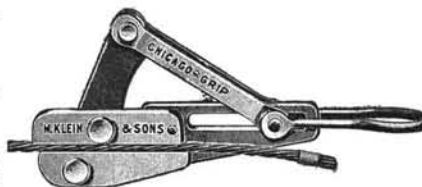

KLEIN'S CHICAGO GRIPS

With Bronze Lined Jaws

Construction engineers are demanding grips that will not slip under heavy loads and which will not damage the conductor or strand. These requirements are met by welding a lining of bronze into the jaws of standard Chicago Grips, indicated by "B" following catalog number.

In order to make standard grips available for conductors of larger diameters they can be further modified by plating the lower jaws to required additional width and fitting an upper jaw of corresponding width, but in one piece, indicated by "BP" following catalog number.

Whether for copper, copper-weld, aluminum or aluminum cable steel reinforced (ACSR) or steel strand these grips will answer the problem.

Ascertain the maximum tension anticipated and the over-all diameter of the conductor or strand to be used and consult the table below. All orders must state maximum tension load and overall diameter of conductor or strand.

These tools are made to order only. Parts are held in blank at factory and shipment can usually be made in from 14 to 21 days.

No.	Max. Diam. Conductor	Max. Safe Load, Lbs.	Wt. Lbs. Each
1613-30B	.1875	1,500	1 1/2
1613-40B	.3125	2,250	2 3/4
1613-50B	.50	4,000	7 1/2
1611-20B	.50	2,200	2 1/2
1626-39B	.75	3,750	7 3/4
1626-40B	.9375	3,750	7 3/4
*1626AB	.8125	6,000	7 3/4
*1628-5B	.375	6,000	5
*1628-6B	.50	8,000	8 1/2
†*1628-6BP	.75	8,000	9 1/2
*1628-16B	.625	15,000	14
†*1628-16BP	1.125	15,000	15
*1628-30B	1.50	20,000	23 1/2

* Forged from tough alloy steel, all parts heat treated so as to get maximum strength without excess weight.

† These grips are also plated to accommodate the larger diameter cables.

CONSTRUCTION TOOLS

NO. 1700-30 KLEIN'S CHICAGO LINEMEN'S TOOLS

Set is combination of Chicago Grip No. 1613-30 with Howes Wire Tool No. 1702-20.

For No. 6 wire and smaller down to No. 13.

No. 1700-30, Weight, 4 lbs.

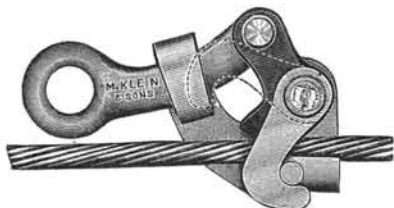

IMPROVED HAVEN'S GRIPS

For plain or stranded wire No. 6 to 3/4-inch diameter. Made with swing latch which engages stud on lower jaw.

NO. 1803 KLEIN'S HAND LINES

Rope is best quality Manila and does not twist. Spliced to eye of snap hook with galvanized steel thimble.

Snap hook is drop forged and similar to those used on safety straps except that it has round eye.

No. 1803-60, 75 Ft. of 3/8 In. Rope.

No. 1803-120, 120 Ft. of 3/8 In. Rope.

Klein's Snap for Hand Lines

Is used on hand lines, 1803 series.

No. 443A, Forged Snap, Eye 1 1/16 In. I. D.

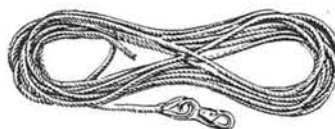

NO. 1802-30 KLEIN'S SELF-LOCKING TROUBLEMEN'S BLOCKS



Especially for use with Klein's Wire Grips. No. 1802-30 is furnished with 25 feet 3/8-inch Manila rope, 2 1/2 pounds. Consists of light steel shell blocks galvanized, fitted with snubbing hook to lock load in any position. To lock load, pull luff rope under hook. To release, simply pull rope. Blocks are arranged with

spring guard snap hooks. When pulling up wire to make a splice, it may be used with two grips attached to snaps or with hook to anchor to an insulator-pin or other convenient anchorage.

LINEMEN'S CANVAS TOOL BAGS, LEATHER BOTTOMS

Made of one piece white duck reinforced all around bottom with heavy bag leather, 3 1/4 inches up on 5102 series, 8 inches up on 5105 series.

Bottom is made of heavy leather outside and duck inside, lock stitched all around. Bottom is protected with strong steel studs.

Bottoms and sides joined together with lock stitched leather welt seams.

Mouth of bag is formed by a 12-gauge steel frame.

Canvas is clinched between this frame and an inside secondary steel frame.

Has harness leather handles and two retaining straps with buckles.



No.	Size In.	Wt. Lbs. Each	No.	Size In.	Wt. Lbs. Each
5102-18	18	3 3/4	5105-18	18	4 1/2
5102-20	20	3 7/8	5105-20	20	4 3/4

Other sizes on order.

CONSTRUCTION TOOLS

KLEIN'S TOOL-KITS

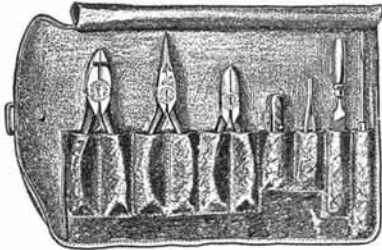

Designed for mechanics, service men and electricians. Contains long nose plier, special side cutting plier, diagonal cutting plier, electrician's knife, a pair of electrician's tempered tweezers, 4½-inch file and a screw driver with insulated handle. All contained in a Keratol roll fastened with a strong strap and buckle.

NO. 3109-20 KLEIN'S COMBINATION STEEL LAG SCREW WRENCHES

This wrench is forged from select bar steel. The slot is formed in a cross shape and will fit machine bolts, nuts or lag screws from ⅜ inch to ⅝ inch. The small end of the wrench is arranged for ⅝-inch machine bolts or lag screws. The round hole allows the end of a bolt to come through as the nut is run on.



The jaw is wider at its upper portion and when this wrench is put on a nut or bolt the tendency is to draw the bolthead or nut into the wrench and prevent slipping off. Weight per dozen, 20 pounds. Nos. 3109-20, Length, 13½ Inches.



KLEIN'S LINEMAN'S WRENCHES

Bell System Type

This wrench is forged from selected bar steel and is of the open end type with 2 openings of different size at each end. A hole is also provided for turning in pole steps, etc. Weight per dozen, 21 pounds.

No. 3146, for ⅝-Inch Hardware.
No. 3146-A, for ¾-Inch Hardware.

PORTER NEW EASY BOLT CLIPPERS

Has japanned malleable iron handles, rubber buffers, and tempered tool steel jaws. The jaws can be dressed when necessary with a mill file. Furnished with clipper cut or center cut jaws.



Approximate Length.....in.	
For Annealed Bolts in Thread.....in.	
For Soft Rods.....in.	
For Spring Wire with Special Temper Jaws Only...in.	
Approximate Weight.....lbs.	

No.	0-NE	1-NE	2-NE	3-NE
	18	24	30	36
	5/16	3/8	1/2	5/8
	1/4	5/16	3/8	1/2
	.203	.238	.284	.340
	3 1/4	5 1/4	8 1/2	12 1/2

PORTER ELECTRIC WIRE CUTTERS

With Insulated Handles



Jaws open to accommodate wire and cable insulation; beveled mostly on one side. In using them on bolts or rods, cutting capacity is limited to opening at heel of jaws, not at point. The wider opening does not give them greater power capacity.. Will not cut hardened material.

No.	Length Tool Inches	Average Opening Jaws Inches	To Cut, Inches		Net Weight Pounds
			Annealed Bolts in Thread	Soft Rods	
0-WC	18	1/2	5/16	1/4	3 1/2
1-WC	24	3/4	3/8	5/16	5 1/2
2-WC	30	1 1/8	1/2	3/8	9
3-WC	36	1 1/4	5/8	1/2	13 1/4

SAFETY STRAPS

KLEIN'S SAFETY STRAPS

Klein Safety Straps are made in various patterns in a choice of two materials.

First quality back stock vegetable tanned harness leather.

The new Klein-Kord fabric especially made for this purpose.

In all cases sewing is with genuine linen thread, hot waxed and lock stitched. Riveted by hand with solid copper rivets.

All buckles, including tongues, are drop forged, tested to 1500 pounds. There are three patterns of drop forged, tested snaps available as illustrated below.



Standard Snaps

Have wide nose covering spring latch protecting it from accidentally twisting out of Dee Ring, and can be used with any Dee.

Straps listed with plain catalog numbers have Standard Snaps.

Hank's Snaps

Are of special construction and must be used in conjunction with Hank's Dee Rings on belt.

Straps listed with "H" prefixing catalog numbers have Hank's Snaps.



Klein-Lok Snaps

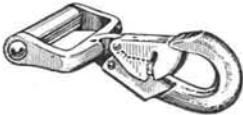

Have a twin latch arrangement. Both latches must be pressed simultaneously to release. Full factor of safety. Can be used with any Dee.

Straps listed with "KL" prefixing catalog numbers have Klein-Lok Snaps.

KLEIN-KORD FABRIC SAFETY STRAPS

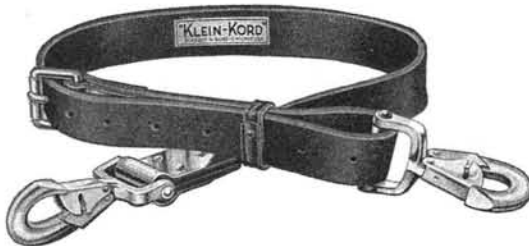

No.	Size	Wt. Lbs. per Doz.
5233	1 3/4 in. x 5 ft. 8 in.	30
H5233	1 3/4 in. x 5 ft. 8 in.	30
KL5233	1 3/4 in. x 5 ft. 8 in.	30

KLEIN'S LEATHER SAFETY STRAPS

No.	Leather Wear Pads Size	Wt. Lbs. per Doz.
5251	1 3/4 in. x 5 ft. 8 in.	30
H5251	1 3/4 in. x 5 ft. 8 in.	30
KL5251	1 3/4 in. x 5 ft. 8 in.	30



No. 5251

Copper Wear Pieces

No.	Size	Wt. Lbs. per Doz.
5250	1 3/4 in. x 5 ft. 8 in.	30
H5250	1 3/4 in. x 5 ft. 8 in.	30
KL5250	1 3/4 in. x 5 ft. 8 in.	30
5253	2 in. x 5 ft. 8 in.	39
H5253	2 in. x 5 ft. 8 in.	39
KL5253	2 in. x 5 ft. 8 in.	39

Bell System Type

No.	Size	Wt. Lbs. per Doz.
5257S	2 in. x 5 ft. 1 1/2 in.	38
5257L	2 in. x 5 ft. 10 in.	40

N. E. L. A. Specifications

5258	2 in. x 5 ft. 6 in.	39
------	---------------------	----

Any of above furnished with 15 inch Long wear Pad to order at no extra cost.

CONSTRUCTION TOOLS

NO. 201 KLEIN'S SIDE CUTTING PLIERS



Nose and all edges rounded and shoulder of head removed.
 No.....201-6NE 201-7NE 201-8NE 201-9NE
 Wt. Lbs. per Doz... 5 7½ 12 12½

NO. 201 KLEIN'S DIAMOND SPECIAL SIDE-CUTTING PLIERS

Has handles shaped to the curvature of the hand. Powerful leverage and keen reinforced cutting knives makes this plier adaptable for heavy cutting in telephone, telegraph and power line work. Full clearance back of the knife permits use on insulated wire.



Has polished head and handles temper blued. Packed 6 in a box.

Cat. No.	Size Inches	Wt. Lbs. per Doz.	Cat. No.	Size Inches	Wt. Lbs. per Doz.	Cat. No.	Size Inches	Wt. Lbs. per Doz.
201-5	5	3	201-7	7	7½	201-9	9	12½
201-6	6	5	201-8	8	12			

NO. 212 KLEIN'S DIAMOND SPECIAL SIDE-CUTTING PLIERS

With Sleeve Joint Twisters



Handles are curved to fit hand. Powerful leverage and keen reinforced cutting knives make this plier adaptable for heavy cutting in telephone, telegraph and power line work. These pliers have chambers for twisting double sleeve joints. Has polished head and handles temper blued.

Cat. No.	Size Inches	For Sleeve		Weight, Lbs. per Dozen
		No.	B. & S.	
212-6	6	17	.045	5
212-7	7	17	.045	7½
212-8	8	10	.104	12

NO. 232 KLEIN'S END CUTTING PLIERS

Stout jaws and broad cutting knives.

No.
232-5½
232-7



NO. 303-6 KLEIN'S LONG NEEDLE NOSE PLIERS

Long nose permits use in confined spaces. Has polished head and handles temper blued. Length 6 inches. Weight per dozen, 3 pounds.

NO. 202 KLEIN'S OBLIQUE CUTTING PLIERS

Electricians, telephone men and switchboard builders will find this plier a most useful tool. Cuts close, the narrow head permitting use in confined places. Knives are perfectly fitted so that they meet accurately at all points.

Has polished head and handles temper blued.



Cat. No.	Size Inches	Weight, Pounds per Dozen
202-5	5	4
202-6	6	4¼

NO. 301 KLEIN'S LONG NOSE PLIERS WITHOUT CUTTERS

For the electrician and general mechanic. Adaptable to stripping the ends of insulated wire and the extra long reach of the jaws permits working in confined spaces.

Has polished head and handles temper blued.



Cat. No.	Size Inches	Wt. Lbs. per Doz.	Cat. No.	Size Inches	Wt. Lbs. per Doz.
301-5	5	2¾	301-6	6	3

CONSTRUCTION TOOLS

NO. 203 KLEIN'S LONG NOSE SIDE CUTTING PLIERS

For the electrician and general mechanic. Adaptable to stripping the ends of insulated wire. The extra long reach of the jaws permits working in confined spaces. Has polished head and handles temper blued.

Cat. No. 203-5

Size Inches 5

Wt. Lbs. per Doz. 2¾

Cat. No. 203-6

Size Inches 6

Wt. Lbs. per Doz. 3



NO. 305-6 KLEIN'S LONG FLAT NOSE PLIERS

Has long wide flat nose. Inside of jaws left smooth if desired. Has polished head and handles temper blued. Length, 6 inches. Weight per dozen, 3½ pounds.

NO. 206-6 KLEIN'S LONG FLAT NOSE SIDE CUTTING PLIERS

Has long wide flat nose and cutting knives. Smooth jaws if desired. Has polished head and handles temper blued. Length 6 inches. Weight per dozen, 3½ pounds.



NO. 304-6 KLEIN'S LONG DUCK BILL PLIERS

For general use. Jaws are wider and heavier than those of flat nose pliers.

Has polished head and handles temper blued. Length, 6 inches. Weight per dozen, 3¼ pounds.

NO. 205-6 LONG DUCK BILL SIDE CUTTING PLIERS

General use. Jaws are wider and heavier than those of flat nose pliers. Has polished head and handles temper blued. Length, 6 inches. Weight per dozen, 3 pounds.



NO. 301-C KLEIN'S LONG NOSE CORD CRIMPING PLIERS

This plier is a long nose type with special opening for crimping switchboard cords to make them fit into the plugs more easily. Size, 6 inches. Weight per dozen, 2¾ pounds.

NO. 316 KLEIN'S LONG NOSE PLIERS

Particularly adapted for telephone work. Jaws are 2 inches long with 1/16-inch point. Handles are 4 inches long, temper blued. Polished head and jaws. Size, 6 inches. Weight per dozen, 2¾ pounds.



NO. 316-S KLEIN'S LONG NOSE PLIERS With Sleeve Opening

Jaws are 2 inches long with 1/16-inch point. Has openings for No. 17 B. & S. double tube copper sleeves. Handles 4 inches long, temper blued; polished head and jaws. Size, 6 inches.

NO. 406-6½ KLEIN'S SLIP JOINT PLIERS

This plier embodies all the advantages offered by a tool of this type. Has a wire cutter and a screwdriver handle. Has polished head and handles temper blued. Length, 6½ inches. Weight per dozen, 7 pounds.



NO. 302-6 KLEIN'S LONG CURVED NOSE PLIERS

A handy plier for working around switchboards, terminals and telephones, due to the nose being curved. Angle is arranged to give full clearance and prevent skinning of knuckles. Adaptable to a variety of uses. Jaws will not lose their shape or set due to pressure applied, owing to quality of steel used, its hardening and tempering.

Weight per dozen, 2¾ pounds. Has polished head and handles temper blued. Length, 6 inches.

CONSTRUCTION TOOLS

NO. 245 KLEIN'S OBLIQUE CUTTING PLIERS

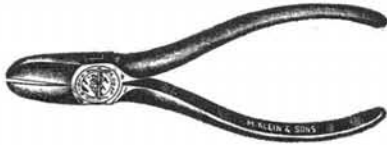

Can easily be carried in vest pocket.
For electricians, telephone men and switchboard builders.
No. 245-5, 5-Inch, Weight per Doz., 4 Lbs.

NO. 202 KLEIN'S NARROW NOSED OBLIQUE PLIERS

This plier has narrow hinge and pointed nose.
For telephone and radio work.
No. 202-5A, 5-Inch, Weight per Doz., 4 Lbs.
No. 202-6A, 6-Inch, Weight per Doz., 4 1/4 Lbs.

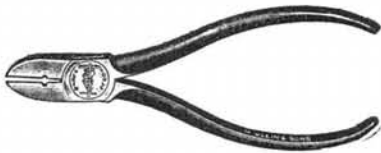
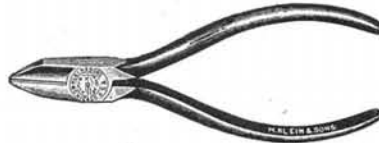

**NO. 240 KLEIN'S OBLIQUE CUTTING PLIERS
With Wire Stripping Notch**

Has notch for stripping small wires placed 3/16 inch from hinge and has diameter of .052 inch.
No. 240-5, 5-Inch, Weight per Doz., 4 Lbs.
No. 240-6, 6-Inch, Weight per Doz., 4 1/4 Lbs.

NO. 203-8 KLEIN'S LONG NOSE CUTTING PLIERS

Made for use with heavier gauge insulated wire.
The round nose is for forming loops and a flat space is provided ahead of the knife for holding objects securely or for cracking insulation.
No. 203-8, Weight per Doz., 8 Lbs.



NO. 203-8N KLEIN'S LONG NOSE CUTTING PLIERS

This plier is same as 203-8 but is fitted with stripping notch in knife. Notch is regularly furnished to take No. 12 A. W. G. insulated wire but can be varied for other sizes to order.
No. 203-8N, Weight per Doz., 8 Lbs.

KLEIN'S LONG FLAT NOSE SPRING ADJUSTING PLIERS

Hollow ground on outside of jaws to reach between and grasp springs easily.
No. 311-5 1/2, 5 1/2-Inch, Weight per Doz., 3 1/4 Lbs.



NO. 5116 KLEIN'S DETACHABLE PLIER HOLSTERS

Made of heavy harness leather with loop to slip over belt.
Carries 7, 8 or 9-inch side cutting pliers.
Mouth of pocket is framed to hold open position permanently.
Length, 10 inches.
Weight per dozen, 6 pounds.



NOS. 5107 AND 5112 LEATHER PLIER POCKETS

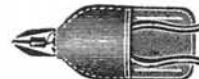

Made of good quality leather. Has slits through which belt is inserted. No. 5112 is the same as No. 5107 except that plier does not protrude.
No. 5107, Weight per Dozen, 2 1/2 Pounds.
No. 5112, Weight per Dozen, 2 1/2 Pounds.

CONSTRUCTION TOOLS**NO. 408-8 KLEIN'S BENT NOSE SLIP JOINT PLIERS**

For use in difficult places. An excellent general purpose tool. Has polished head and handles temper blued. Length, 8 inches.

Weight per dozen, 8 pounds.

NO. 235-6 KLEIN'S DIAGONAL CUTTING PLIERS

This plier has many uses. It has long cutting knives well matched and the head is narrow to permit its use in confined places.

Has polished head and handles temper blued. Length, 6 inches.

Weight per dozen, 4½ pounds.

**NO. 242-6 KLEIN'S OBLIQUE CUTTING PLIERS**

Heavy pattern for general work. The knives are perfectly fitted, so that they meet accurately at all points.

Will be found particularly satisfactory where it is not necessary to reach into confined spaces.

Has polished head and handles temper blued.

Cat.
No.
242-6

Size
Inches
6

Weight, Pounds
per Dozen
4¼

NO. 407-7 KLEIN'S UTILITY SLIP JOINT PLIERS

Heavy duty type. Adaptable as pipe wrench or wire cutter. Has sure grip jaws for irregular shapes.

Polished head and handles temper blued. Length, 7 inches. Weight per dozen, 7½ pounds.

**KLEIN'S LINEMEN'S POLE CLIMBERS**

Also Called Spurs or Hooks

Safety is the first and vital point in considering linemen's pole climbers. The lineman going up a pole depends entirely upon his spurs.

To assure utmost dependability Klein Climbers are forged from special steels and are individually tempered. Shanks and gaffs are tested to insure perfect riveting and temper.

Leg iron or shank is made of spring steel, gaff or spur is forged from tool steel.

The shape of Klein Climbers has been carefully considered. It is the result of many years' experience and much practical suggestion from linemen. Klein Climbers have flexible shanks and yield readily to pressure of leg; they do not chafe. Gaff or spur is correct in shape, set of angle and temper. It is hand riveted to leg iron in secure manner.

KLEIN'S EASTERN CLIMBERS

When ordering specify length of shank desired. Measure from instep to extreme end. Other than stock sizes to order. Tested before leaving factory.

No. 1901

Stock sizes, 15, 15½, 16, 16½, 17, 17½ and 18 inches. Has punched strap loops. Packed 1 pair in a carton. Weight 3⅝ pounds.

No. 1900

Same and same sizes as No. 1901 but has riveted strap loops. Packed 1 pair in a carton. Weight 3⅝ pounds.

No. 1903

Light weight pattern with riveted strap loops. Packed 1 pair in a carton. Weight 2⅞ pounds.

No. 1907

This is the standard tree climber used by forest rangers, top loggers, fire wardens, surveyors, etc. Made in all standard sizes.

Has punched strap loop. Gaffs, or spurs, are 5½ inches long measured on the outside and 3 inches long measured on the underside. They are set high in the leg iron so that points clear the ground.

Packed 1 pair in a carton.



STRAPS, PADS AND TOOL BELTS

KLEIN'S CLIMBER STRAPS AND PADS

Set consists of 2 calf straps 1 1/4 x 22 in. with 4x4 in. pads and 2 ankle straps 1 1/4 x 22 in. Leather is first quality harness leather. Buckles drop forged, fitted with roller.



Cat. No.	Description	Wt. Lbs. per Doz. Sets
5301-1	Plain Pads.....	15
5301-2	Sheep-lined Pads.....	16
5301-3	Felt-lined Pads.....	16
Straps, Only		Doz. Pr.
5301-4	Plain Straps, 2 Straps.....	6
5301-5	Plain Straps, Plain Pads, 2 Each.....	9
Pads, Only		Doz. Pr.
8200	Sheep-lined, 4x4 In.....	3
8201	Felt-lined, 4x4 In.....	3
8202	Plain Leather, 4x4 In.....	3

Extra length straps can be made to order at slightly higher prices.

Pads made of select leather, arranged with loops through which to slip climber strap.

KLEIN'S CLIMBER STRAPS AND PADS

Bell System Type

Set consist of 2 calf straps 1x22 in. with 2 special pads and 2 ankle straps 1x26 in.



Cat. No.	Description	Wt. Lbs. per Doz. Sets
5301-6	With Plain Pads.....	14
5301-7	With Sheep-lined Pads.....	15
5301-8	With Felt-lined Pads.....	15
Straps, Only		Doz. Pr.
5301-9	Calf Straps, 1x22 in., 2 Straps.....	5
5301-10	Ankle Straps, 1x26 in., 2 Straps.....	6
Pads, Only		Doz. Pr.
8203	Plain Leather.....	4
8204	Sheep-lined Leather.....	5
8205	Felt-lined Leather.....	5

Pads made of select leather, arranged with loops for climber straps and climber. Tapering 3 3/4 inch to 2 3/4 x 6 1/4 inch deep.

KLEIN'S TOOL BELTS

All Klein Belts are made of first quality vegetable tanned harness leather. Sewing is with genuine linen thread, hot waxed, lock stitched. Rivets are solid copper, hand set with burrs. Buckles, including tongues, and Dee Rings are steel drop forgings tested to 1500 lbs.

Catalog numbers prefixed by the letter "H" indicate belts fitted with Hank's Dee Rings which must be used with Hank's Safety Straps. All other makes are fitted with Standard Double Bar Dees.

To insure proper fit select size that allows heel of Dee Rings to come about 1 inch in front of hip bones as per following table.

Distance Between Dee Rings, In.	20	22	23	24	26	28	30
Belt Size, In.....	36	38	40	42	44	46	48



DROP FORGED DEE RINGS AND BUCKLE



No. 5204 DE

KLEIN'S TOOL BELTS

With Standard Dees

No.	Width In.	Wt. per Doz.
5204	3 1/2	32
5205	*2 1/4	33
5202	2 1/4	30

With Hank's Dees

H5204	3 1/2	32
H5205	*2 1/4	33
H5202	2 1/4	30

With Plier Pocket, Knife Snap and Tape Thong Attached

With Standard Dees		With Hank's Dees			
5204DE	3 1/2	37	H5204DE	3 1/2	37

* Double thickness.

CONSTRUCTION MATERIAL

DIAMOND D H D HAMMER DRIVE ANCHORS

For nailing to concrete, brick or stone. Made of aluminum alloy, with steel nails, hot galvanized. Holds greater load when fastened to stone than wood screw screwed into wood.



Diam. and Length of Shield In.	Diam. Drill to Use In.	Std. Pkg.	Wt. Lbs. per 100	Diam. and Length of Shield In.	Diam. Drill to Use In.	Std. Pkg.	Wt. Lbs. per 100
3/16 x 7/8	3/16	100	1 1/4	5/16 x 2 1/4	5/16	100	6
3/16 x 1 1/4	3/16	100	1 1/2	5/16 x 2 3/4	5/16	100	7 1/2
1/4 x 1	1/4	100	2 1/4	3/8 x 2	3/8	100	8
1/4 x 1 1/4	1/4	100	2 3/4	3/8 x 3 1/4	3/8	100	14
1/4 x 1 1/2	1/4	100	3 1/2	1/2 x 2 1/4	1/2	50	17
5/16 x 1 1/4	5/16	100	3 1/2	1/2 x 3 1/2	1/2	50	25
5/16 x 1 3/4	5/16	100	5				

DIAMOND CALKING ANCHORS



Diameter Bolt or Screw, In.	Size Hole, Inches		Suggested Safe Load Pounds	Std. Pkg.	Weight Pounds per 100
	Diameter	Depth			
No. 6-32	1/4	3/8	80	100	1
No. 8-32	5/16	1/2	90	100	1 1/2
No. 10-24	7/16	5/8	175	100	2
No. 12-24	1/2	3/4	320	50	3 1/2
1/4-20	1/2	7/8	400	50	4 1/2
5/16	5/8	1	480	50	11
3/8	3/4	1 1/4	720	50	16
7/16	7/8	1 1/2	950	50	24
1/2	7/8	1 1/2	1000	50	24
5/8	1 1/8	2	1250	50	41

DI-EN-KEY EXPANSION BOLTS

With Malleable Iron Expansion Shields

For use in suspension rods for mine hangers, steam and water pipes, sprinkler systems and allied lines. The smaller sizes are adapted to opera chairs and school furniture work.



Diam. Screw Inches	Length Inches	Outside Diam. Inches	Diam. Screw Inches	Length Inches	Outside Diam. Inches
1/4	1	7/16	1/2	2 1/2	7/8
5/16	1 3/4	9/16	5/8	2 1/2	1
3/8	2	1 1/16	3/4	3 3/4	1 1/4

KEYSTONE INTERLOCKING EXPANSION SHIELDS

Prevents the nut being drawn out of the shield when heavy loads are applied. Guides the mechanic in determining when to stop tightening up the bolt. Prevents the nut being drawn past the point of maximum expansion. Locks the two shields and the nut into a unit of resistance against the load, making it impossible to pull out the nut without extracting the shield, also thus increasing the holding power of the expansion.

Made of malleable iron for durability and strength.



Diam. Screw or Bolt Inches	Length Shield Inches	O.D. and Size Drill to Use Inches	Diam. Screw or Bolt Inches	Length Shield Inches	O.D. and Size Drill to Use Inches
1/4	1 1/2	1/2	3/4	3 1/4	1 1/8
5/16	1 3/4	9/16	7/8	4	1 1/2
3/8	2	1 1/16	1	4 1/4	1 5/8
7/16	2 1/2	7/8	1 1/4	6	2 1/8
1/2	2 1/2	7/8	1 1/2	7 1/2	2 1/2
5/8	2 7/8	1			

CONSTRUCTION MATERIAL

DIAMOND MALLEABLE IRON EXPANSION SHIELDS



Long Standard					Short Standard						
Diam. Screw Inches	Length Inches	Outside Diam. Inches	Diam. Screw Inches	Length Inches	Outside Diam. Inches	Diam. Screw Inches	Length Inches	Outside Diam. Inches	Diam. Screw Inches	Length Inches	Outside Diam. Inches
1/4	1 1/2	1/2	5/8	3 1/2	7/8	3/16	1	3/8	7/16	2	1 1/16
5/16	1 3/4	9/16	3/4	3 1/2	1 1/8	1/4	1	1/2	1/2	2	3/4
3/8	2 3/4	5/8	7/8	5	1 3/8	5/16	1	1 1/2	5/8	2	7/8
7/16	2 3/4	11/16	1	5	1 1/2	3/8	2	1 7/8	3/4	2	1 1/8
1/2	3 1/2	3/4	1 1/4	6 1/2	1 7/8						

KEYSTONE SINGLE EXPANSION SHIELDS For Machine Bolts and Machine Screws



Diam. of Screw or Bolt Inches	Length Inches	Outside Diam. and Size Drill to Use, Inches	Diam. of Screw or Bolt Inches	Length Inches	Outside Diam. and Size Drill to Use, Inches
1/4	1 3/16	1/2	5/8	2	1
5/16	1 1/2	9/16	3/4	2 3/4	1 3/16
3/8	1 5/8	1 1/16	7/8	2 1/2	1 1/2
1/2	1 7/8	1 3/8	1	2 3/4	1 5/8

STYLE B DIAMOND SUPER-GRIP EXPANSION SHIELDS

Shield expanded by long, tapered cone shaped end of bolt. Nut grips work and expands shield. Bolts galvanized by the hot drip process. One calking tool furnished free with each box of bolts. Prices include bolts.



Size In	O.D. In.	Length, Inches							
		1 1/2	2	2 1/2	3	3 1/2	4	5	6
		Per 100	Per 100	Per 100	Per 100	Per 100	Per 100	Per 100	Per 100
1/4	7/16	\$15.50	\$15.65	\$15.80	\$15.95
5/16	1/2	23.00	23.50	24.00	24.50
3/8	9/16	29.25	30.00	\$30.75	\$31.50	\$33.00	\$34.50
1/2	3/4	44.40	45.65	47.00	48.20	49.40
5/8	7/8	76.40	78.25	80.00	83.80	87.60
3/4	1	111.90	114.60	120.00	125.40

NO. 13 GRAYBAR LINEMAN'S DOUBLE FACED HAMMERS



Bell System Type

Drop forged oil tempered head with special short neck designed to strike a heavy accurate blow in a confined space.

Length over all, 15 inches.

Weight of head, 2 1/4 pounds. Weight of hammer complete, per dozen, 35 pounds.

NO. 4638 GRAYBAR LINEMAN'S CHIPPING HAMMERS

Bell System Type

Drop forged oil tempered, specially made for line construction work.

The face is suitable for general use and the pein is suitable for chipping brick work, concrete, stone, etc., or for riveting.

Length over all, 16 inches.

Weight of head, 3 1/2 pounds. Weight of hammer complete, per dozen, 48 pounds.



CONSTRUCTION MATERIAL**ORANGEBURG FIBRE CONDUIT****Harrington (Sleeve) Joint Type**

Orangeburg Fibre Conduit is manufactured by The Fibre Conduit Company at Orangeburg, New York and Richmond, Indiana. These two plants are equipped with the most modern machinery for the manu-

facture of fibre conduit and are devoted exclusively to the manufacture of this product.

Orangeburg Fibre Conduit is made from wood fibre. The conduits are dried in automatic driers and then thoroughly impregnated with a preserving compound. The ends of the conduits are accurately machined to insure tight joints.

During the entire process of manufacture many inspections are made to insure that the finished product meets the most exacting specifications.

During the past 41 years many millions of feet of Orangeburg Fibre Conduit have been installed in underground systems under all conditions of soil and climate.

Recent improvements in manufacturing processes have resulted in an even better Orangeburg Conduit. This improved conduit has the following outstanding advantages:

1. Extremely high resistance to water absorption.
2. Higher crushing strength.
3. Higher bending strength.
4. Higher impact resistance.
5. Greater resistance to flattening.

Standard conduit length in all sizes from 1 to 6 inches inclusive is 5 feet; 8-foot lengths are also standard in sizes 2½ to 4½ inches inclusive.

One coupling is supplied with each length.

Inside Diameter Inches	Wt., Lbs. per Foot	Approx. No. Feet *Minimum Carload
1	.60	50000
1½	.85	35300
2	1.05	28575
2½	1.30	23080
3	1.60	18750
3½	1.90	15790
4	2.30	13045
4½	2.65	11325
5	3.25	9235
6	4.25	7060

* Minimum carload, 30000 pounds.

Socket joint conduit supplied on special request.

ORANGEBURG FIBRE CONDUIT BENDS**Harrington (Sleeve) Joint**

45° Bend—5 feet Long, 36 Inch Radius



90° Bend—5 feet Long, 36 Inch Radius

One coupling is supplied with each bend or elbow.

I.D. In.	Radius Standard Bends, Inches	I.D. In.	Radius Standard Bends, Inches
	45° and 90°		45° and 90°
1	18-24-36	3½	36
1½	18-24-36	4	36
2	18-24-36	4½	36
2½	24-36	5	36
3	36	6	36

CONSTRUCTION MATERIAL

ORANGEBURG FIBRE CONDUIT ELBOWS

45° and 90° Elbows

Standard Radius Inches		45° and 90° Elbows	Standard Radius Inches		45° and 90° Elbows
Size Inches	Size Inches				
1	5.75	3½	15.0		
1½	8.25	4	16.0		
2	* 9.5	4½	18.0		
2½	10.5	5	24.0		
3	13.0				

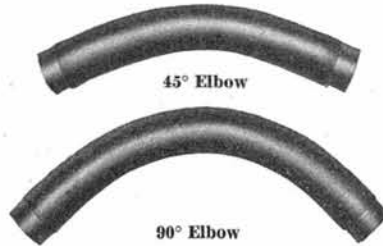

Socket joint type bends and elbows will be supplied upon special request.

ORANGEBURG FITTINGS

Fittings such as manhole bells, plugs, fibre conduit to metal conduit adapters and reducers, fibre to fibre adapters and reducers, etc., are available. Information regarding such fittings and specialties gladly furnished on request.

Orangeburg Fibre Conduit Field Tooling Machines

A light weight, readily portable field tooling machine selling at a nominal price is available for use in milling joints on the job. This machine provides a means of making satisfactory joints in the field with a minimum expenditure of time and labor. Price information and further details of this machine furnished on request.

NATCO STANDARD SINGLE DUCT CLAY CONDUIT



Adapted for high tension power lines, single cable terminals or for low tension laterals, as in telephone or signal lines.

In building up duct banks, this conduit provides two heavy insulating walls between adjacent cables, and permits breaking or staggering of all joints throughout the duct bank.

Permits the splaying or separation of individual duct lines in approaches to manholes.

Conduit is scarified lengthwise on the four outer sides, to provide anchorage for bedding mortar.

The inner edges of the duct entrances are properly bevelled and smoothed to eliminate projections and to make safe the pulling of cables.

Certain square single duct shapes are provided with through dowel holes in the corners, permitting the use of steel dowel pins for assembling, centering and aligning such duct lines.

Standard length, 18 inches, except in the 5¼-inch round bore shape which is 24 inches long. Short lengths as shown in table, are available for staggering joints.

Nominal Bore In.	No. Duct Holes	Std. Lgth. In.	Duct Ft. Pc.	Actual Size Duct Hole In.	Approx. Out. Side Dimen. In.	Made in Short Lghts. In.	Min. Car-load Duct Ft.
3¼ Rd.	1	18	1½	3¾	4½x4½	3, 4, 6, 9, 12	7800
3½ Rd.	1	18	1½	3⅝	4⅞x4⅞	3, 4, 6, 9, 12	6900
4¼ Rd.	1	18	1½	4¾	5⅝x5⅝	3, 4, 6, 9, 12	5700
5¼ Rd.	1	24	2	5¾	6⅞x6⅞	3, 4, 6, 8, 12	4000
3¼ Sq.	1	18	1½	3¾	4¾x4¾	3, 4, 6, 9, 12	6100
3½ Sq.	1	18	1½	3⅝	5 x5	3, 4, 6, 9, 12	5700
4¼ Sq.	1	18	1½	4¾	5⅞x5⅞	3, 4, 6, 9, 12	4800

NATCO SOCKET JOINT SINGLE DUCT CONDUIT

Natco Single Duct Conduit is also manufactured in a new socket joint type, which is supplied in 3½, 4 and 4½-inch round bore and in either 18 or 24-inch standard lengths. This new type of duct is self-centering, provides positive alignment, lays up fast and can be installed by ordinary labor. If desired, the joints may be readily troweled or sealed with cement mortar. This new type of conduit is especially adapted for single duct lateral lines, also equally suitable for duct bank construction where this type of joint is preferred.



Nominal Bore.....inches	3½ Rd.	4 Rd.	4½ Rd.
Length.....inches	18 and 24	24	24
Actual Size of Duct Holes.....inches	3¾	4⅞	4¾

Also furnished in bends and mitred sections.

CONSTRUCTION MATERIAL

NATCO STANDARD MULTIPLE DUCT CONDUIT

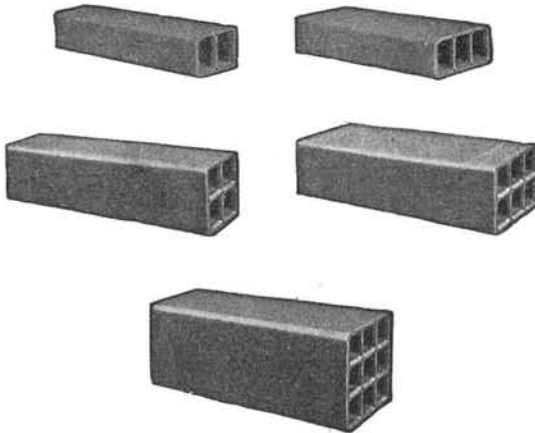

Particularly adapted for telephone, telegraph, railway signal, fire alarm and low tension light and power service. The large units are economical and quick to install, due to their longer lengths and multiplicity of duct holes.

At the extreme ends of each piece of conduit, a smooth surface is left to permit wrapping each joint with tape or fabric to exclude joint mortar from the ducts.

Supplied in either 3¼, 3½ or 4¼-inch square bore shapes and in 2, 3, 4, 6 and 9-way multiple shapes.

The 3¼ inch is the standard bore, while 4¼ inch is the over-size bore, for most telephone service and for certain low tension power and lighting systems, while the 3½ inch bore is frequently specified for certain municipal installation.

Nominal Bore In.	No. Duct Holes	Std. Lgth. In.	Duct Ft. Per Pe.	Actual Size Duct Hole In.	Approx. Outside Dimen. In.	Made in Short Lgths. In.	Min. Car-load Duct Ft.
3¼ Sq.	2	24	4	3⅜	4¾ x 8¾	6, 8, 12	7600
3¼ Sq.	3	24	6	3⅜	4¾ x 12¾	6, 8, 12	7500
3¼ Sq.	4	36	12	3⅜	8¾ x 8¾	6, 9, 12	8400
3¼ Sq.	6	36	18	3⅜	8¾ x 12¾	6, 9, 12	9000
3¼ Sq.	9	36	27	3⅜	12¾ x 12¾	6, 9, 12	9000
3½ Sq.	2	24	4	3⅝	5⅛ x 9⅝	6, 8, 12	6400
3½ Sq.	3	24	6	3⅝	5⅛ x 13⅝	6, 8, 12	6900
3½ Sq.	4	36	12	3⅝	9⅝ x 9⅝	6, 9, 12	7500
3½ Sq.	6	36	18	3⅝	9⅝ x 13⅝	6, 9, 12	8100
4¼ Sq.	2	24	4	4⅜	5⅝ x 11	6, 8, 12	5200
4¼ Sq.	3	24	6	4⅜	5⅝ x 16⅝	6, 8, 12	5400
4¼ Sq.	4	36	12	4⅜	11 x 11	6, 9, 12	6000
4¼ Sq.	6	36	18	4⅜	11 x 16⅝	6, 9, 12	6300
4¼ Sq.	9	24	18	4⅜	16⅝ x 16⅝	6, 8, 12	6800

NATCO SINGLE DUCT BENDS

Standard Shapes		
Bore.....	3¼, 3½ or 4¼	Round or Square
Angle.....	45°	90°
Radius.....inches	12, 18, 24 or 36	12, 18, 24
Arc or Length		
Bore.....inches	3¼, 3½ or 4¼ Rd.	3¼, 3½ or 4¼ Sq.
Length.....inches	18	18
Radius.....inches	36, 60, 72 or 96	36, 60, 72 or 96



Bends also supplied that are scored for splitting apart.

JOINT TAPE

An especially prepared tape is frequently used for wrapping the joints of multiple duct conduit prior to the application of the joint mortar, also occasionally used for wrapping joints of single duct conduit in trench, subway or masonry structures, prior to the pouring of the concrete encasement.

This tape has an adhesive waterproof coating on one side, and is supplied in 4 and 6-inch widths, and put up in rolls of 25 linear yards.

Tape adheres closely and firmly to be glazed surface of the conduit and aids in sealing the joints.

In ordering, specify total number of linear yards required.



CONSTRUCTION MATERIAL

RAINIER WOOD CONDUIT

This conduit is manufactured from yellow pine at the plant at Wilmington, North Carolina, and from Douglas fir at our plant at Centralia, Washington. An economical and satisfactory conduit for the carrying of all forms of lead cable and wires.

Comes in random lengths.

	inches	inches	inches	inches
Outside Meas. . .	5½x5½	5x5	4½x4½	3½x3½
Diameter Bore. . .	4	3½	3	2

Each piece has a mortise at one end and a tenon on the other end.

It is in general use by the large telegraph companies and telephone companies all over the country and by many railroads.

Uses for which it is adapted:

RAILROADS.—Trunking, underground signal wires, high tension transmission lines, yard drainage where clay conduit is easily broken through, and system is usually placed on the surface of the ground.

TELEPHONE COMPANIES.—All underground work.

TELEGRAPH COMPANIES.—All underground work.

POLICE AND FIRE ALARM SYSTEMS.—For carrying wires, either high or low tension under ground.

CENTRAL STATIONS.—For distribution mains and services.

SPECIFICATION CREOSOTE CONDUIT.—Free from large, unsound or loose knots, or other defects which would impair strength. Creosoted steam and vacuum treatment, dead oil of coal tar under pressure either 12 pounds per cubic foot (full cell) or 8 pounds per cubic foot (empty cell) as ordered.

Any additional information regarding the practicability of installing this conduit will be furnished upon request.

Prices on application.



DIAMOND SCREW DUCT RODS

Couplings are made of government bronze. The hickory used in the shaft is selected stock, well seasoned. Threads are accurately cut to ¾-inch U.S.S., 10 threads per inch. Rivets are countersunk. Hickory shafts are ⅞ inch in diameter.

3-Foot Length.

4-Foot Length.



EMPIRE DUCT RODS

Furnished in 2 styles, tapered and straight. Tapered sticks are furnished when not otherwise specified. They measure 1¼ inches at the middle of the rod and taper to 1 inch at coupling. Straight sticks are furnished of uniform diameter 1 inch throughout.

Couplings are malleable iron. Ends are interchangeable. Axles are machined from brass rod, solid head and shouldered on coupling. Wheels are machined at hub to fit axle and shaped to conform to curve of duct. The rod is made of best selected straight grain well seasoned hickory, tapering to 1 inch at coupling.



DOWEL PINS

Pressed steel pins, 5/16 x 3 inches, with an integral central flange or collar, are generally used for joining or aligning individual sections of multiple duct, also certain sizes of square bore single duct conduit together.

Two pins are used at each joint or for each piece of conduit.



CONSTRUCTION MATERIAL

MODEL 564 WESTON VOLT-OHMMETERS



The equipment consists of a Model 301 with four 1000 ohms per volt, voltage ranges of 600/300/30/3 and resistance ranges of either 0-100000 and 0-1000 ohms or 0-1000000, 0-100000 and 0-1000 ohms. A self-contained 4½-volt C battery is provided for potential. A pair of 50-inch test leads is shipped with each Model 564.

Any change in potential of the self-contained battery can be readily compensated for by short circuiting the pin-jacks X-X and adjusting the pointer to the zero ohm position by turning the voltage adjuster located at the top of the nameplate.

All voltage ranges are brought out to pin-jacks. A toggle switch connects the meter in circuit as a voltmeter or ohm-meter. The instrument sensitivity, when used as an ohm-meter, may be changed by a toggle switch from 1 to 100 milliamperes when using the 100000 or 1000-ohm scale; when using the 1000000-100000-1000-ohm instrument the sensitivity may be changed from .1, or 1 to 100 milliamperes. This simplifies checking up trouble in high or low resistance circuits.

Shipping weight, 6 pounds.
 Model 564, 0-1000000-Ohm Instrument.
 Model 564, 0-100000-Ohm Instrument.

WHITNEY BLAKE TELEPHONE WIRES

No. 17 Drop Wire

Copperweld, tensile strength, 220 lbs.; conductivity, 30% Bronze, tensile strength, 170 lbs.; conductivity, 38%.

Diameter over rubber, .110 inch (7/64).

Weight per 1000 feet, twisted pair, 33 lbs.; parallel, 31 lbs.

Bridle or Outside Wires

Size.....	A.W.G.	14	16	18	19	20
Diam. over rubber. in.		5/32	3/16	7/64	3/32	.085
Wt. per 1000 Ft.. lbs.		60	42	31	22	20

No. 17 Abrasion Proof Wire

Diameter Over Rubber.....	in.	.115
Weight per 1000 Feet.....	lbs.	55

Inside Wire

Size.....	A.W.G.	19	22
Diameter Over Rubber.....	in.	3/32	.055
Weight per 1000 Feet.....	lbs.	21	10

Switchboard Wire

Size.....	A.W.G.	19	20
Diameter Over Rubber.....	in.	3/32	.085
Weight per 1000 Feet.....	lbs.	23	18

Flameproof Distributing Wire

Size.....	A.W.G.	19	20	22
Diameter Over Rubber.....	in.	3/32	.085	5/64
Weight per 1000 Feet.....	lbs.	23	17	13

Single Ground Wire

Size.....	A.W.G.	14	18
Diameter Over Rubber.....	in.	5/32	7/32
Weight per 1000 Feet.....	lbs.	27	13

No. 22 Duct Wire

Diameter Over Rubber.....	in.	1/64
Weight per 1000 Feet.....	lbs.	14

Pothead Wire

Size.....	A.W.G.	16	19	20	22
Diameter Over Rubber. in.		1/32	3/32	3/32	3/32
Weight per 1000 Feet. lbs.		37	20	19	17

Weights are 2-conductor, except ground wire.

Coil lengths, 200 to 1500 feet.

The 4-figured numbers shown are the Graybar-Whitney Blake specification numbers.



Copperweld, Twisted Pair, Spec. 3791
 Bronze, Twisted Pair, Spec. 3730



Copperweld, Parallel, Spec. 5791
 Bronze, Parallel, Spec. 5730



No. 18, Twisted Pair, Spec. 4823

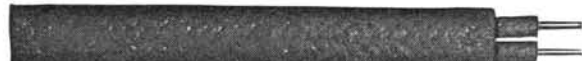

Spec. 4746



No. 19, Twisted Pair, 1/32-Inch Wall Spec. 4926
 No. 22, Twisted Pair, 1/64-Inch Wall Spec. 4256



No. 20, Twisted Pair, Spec. 5758



No. 20, Twisted Pair, Spec. 2056



No. 14, Spec. 2990



Twisted Pair, Spec. 5423



No. 19, Twisted Pair, Spec. 3643

CONSTRUCTION MATERIAL

WHITNEY BLAKE ENAMELED FLAMEPROOF DISTRIBUTING FRAME AND RACK WIRES

Tussah Silk Winds with braided flameproof covering or cotton wound cellulose acetate flameproof coating.

Size.....	A.W.G.	20	22
Weight per 1000 Feet.....	lbs.	9	7

WHITNEY BLAKE TELEGRAPH WIRES

Flameproof Distributing Wire

Size.....	A.W.G.	18	16
Diameter Over Rubber.....	in.	$\frac{7}{64}$	$\frac{5}{32}$
Weight per 1000 Feet.....	lbs.	27	38

Inside Wire

Size.....	A.W.G.	18	16	14
Diameter Over Rubber.....	in.	$\frac{7}{64}$	$\frac{5}{32}$	$\frac{5}{32}$
Weight per 1000 Feet.....	lbs.	26	35	54

Outside or Bridle Wire

Size.....	A.W.G.	12	10
Diameter Over Rubber.....	in.	$\frac{3}{64}$	$\frac{3}{64}$
Weight per 1000 Feet.....	lbs.	80	109

For details of construction see illustrations of similar types of telephone wires.

Weights are 2-conductor.

Coil lengths, 200 to 1500 feet.

Wires can also be manufactured to conform to customer's specifications.

FRICTION TAPE

Sticka Black Friction Tape

A popular-priced tape for general use.
Used to protect the splicing compound on a wire joint from abrasion.
Roll contains $\frac{1}{2}$ pound gross of $\frac{3}{4}$ -inch tape, length 60 feet to a roll.



Victor Black Friction Tape

Protects the splicing compound on wire joints from abrasion.
A high grade tape for outside or inside work.
Roll contains $\frac{1}{2}$ pound gross of $\frac{3}{4}$ -inch tape, 67 $\frac{1}{2}$ feet to a roll.



Amazon ASTM Black Friction Tape

Highest quality friction tape to meet the most strict specifications.
Standard rolls contain $\frac{1}{2}$ pound net of $\frac{3}{4}$ -inch tape, which is 82 $\frac{1}{2}$ feet to a roll.



SPLICING TAPE

Victor Black Rubber Splicing Tape

A good grade, unvulcanized compound.
Will fuse into a homogeneous mass at average air temperature under heat of the fingers.
Half-pound roll gross, .030 inch thick, 21 feet to a roll.



Amazon ASTM Gray Rubber Splicing Tape

A compound of the best quality, partially unvulcanized, high in dielectric and tensile strength.

The adjacent layers adhere readily on a joint and become a solid, homogeneous mass.

Roll weight $\frac{1}{2}$ pound net, $\frac{3}{4}$ -inch tape, .030-inch thick, 26 feet to roll.



MISCELLANEOUS SUPPLIES

Desk Lamp Signals

These desk lamp signals are admirably suited for use in place of the telephone bells in executive offices, hospitals, doctors' offices, etc., where a silent or visual type signal is required. Also adaptable for silent code call systems.

The unit is compact and simple in design, it is finished in chromium and black and the base is of cast brass to provide sufficient weight for desk use. The signals can be used with or without relays, depending upon the local service conditions.

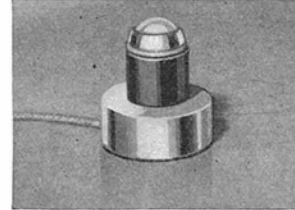

DLS 1

Type DLS-1 desk lamp signal is furnished with a specially treated white lens which, when the lamp lights, gives a brilliant glow and can be furnished in colors of red, green or amber, as desired. A range of 180 degree of visibility is afforded. The units are furnished with standard miniature base brackets for the type T3 and G6 lamps for operation on 1½ to 48 volts. Special units can be furnished with the No. 13 W. E. socket for the No. 2 type switchboard lamp.

Type DLS-2 desk lamp signal is designed for the type G6 low voltage lamps in 6 to 32 volts; also the type S6 lamp for 120 volt operation. The top of the lamp is frosted and acts as a lens. The general Design of this unit is the same as the LDS-1 unit described above.

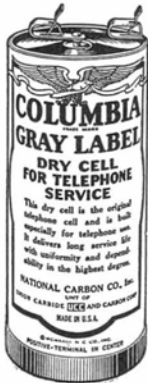

DRY BATTERIES

For Telephone Service

The Columbia Gray Label Battery is designed for telephone transmitter work and meets the demand for a reliable, highly efficient, long-lived cell. Its purpose is to supply small amperage for short periods—during telephone conversations—and it will supply this amperage thousands of times during its life. Metal sealed to protect against leakage, bulging and breakage.

Size of Zinc Can Ins.	Size Overall Ins.	Description	Wt. per Cell	No. in Box	Shipping Wt. per Box
2½ x 6	2¾ x 6¾	Standard Fahnestock Clips	2 lbs.	25	56

The Eveready Long Life Telephone Battery with patented metal seal top is the best battery for telephone work. Especially designed for long service, its extra life more than makes up for its slight extra cost. Made in 6 inch size only.

	Size	Description	Standard Package Quantity	Weight Standard Pkge. Quantity
Columbia Gray Label	2½ x 6	Fahnestock Clips	25	56 lbs.
Eveready Long Life	2½ x 6	Fahnestock Clips	25	57 lbs.

ALPHABETICAL INDEX

Material	Page	Material	Page	Material	Page
A					
Adapters.....	43	Cable Duct Shields.....	365	Corner Brackets.....	330
Adapters, Condenser.....	50	Cable Grips.....	368	Counters.....	150
Adapters, Dial.....	79	Cable Guide.....	366	Cover Hooks, Manhole.....	365
Aerial Cable Jacks.....	353	Cable, Interphone.....	29	Crossarm Bolts.....	338
Anchors.....	341-344, 378	Cable, Lead Covered.....	12-22	Crossarm Braces.....	339
Anchors, Calking.....	378	Cable Splicers' Carts.....	353	Crossarms, Wood.....	324
Anchors, Hammer Drive.....	378	Cable, Switchboard.....	23-29	Cut-In Stations.....	208
Apparatus Blanks.....	3, 109, 110	Cable Terminals.....	30-43, 313	Cutters, Wire.....	371
Apparatus Blanks, Dial.....	81	Cable Terminal Boxes.....	36, 37	Cutting Pliers.....	373-376
Apparatus Blanks, Handset		Cable Terminal Sections.....	38, 39		
Mounting.....	109, 110	Calculagraph Clocks.....	309	D	
Apparatus, Testing.....	284-287	Calking Anchors.....	378	Derricks, Automobile Pole... 348	
Arming Bolts.....	336, 337	Cant Hooks.....	358	Designation Strips.....	74
Arms, Telephone (See Trans-		Cant Hook Handles.....	359	Desk Set Boxes (Subscriber	
mitter Arms)		Carriage Bolts.....	338	Sets).....	200-211
Arms, Transmitter.....	296, 297	Carrying Hooks.....	359	Desk Stands.....	75-77
Attachments, Transmitter... 297		Carts, Cable Splicers'.....	353	Dials.....	78, 79
Augers, Telegraph.....	341	Central Battery Multiple		Dial Adapters.....	79
		Switchboards.....	246-256	Dial Apparatus Blanks.....	81
B					
Backboards.....	4, 5	Central Battery Non-Multi-		Dial Mountings.....	80, 81
Barricades, Folding.....	365	ple Switchboards.....	224-226	Dial Number Plates.....	81
Barrow Reels.....	362	Central Battery Telephones		Dial Tester.....	82
Bars, Digging.....	361	276-281	Diggers.....	344
Batteries, Primary Cells... 303, 304		Chairs.....	318	Digging Bars.....	361
Batteries, Storage.....	305	Chicago Grips.....	369	Digging Spuds.....	361
Battery Boxes.....	7	Circuit Breaker.....	11	Distributing Brackets.....	330
Battery Chargers, Tungar 306, 307		Circuits, Transmission.....	262	Distributing Frames.....	83-85
Battery Connector.....	7	Clamps, Cable.....	327	Distributing Frame Wire... 299	
Bells, A.C. or D.C.....	5	Clamps, Ground Rod.....	334	Distributing Rings.....	86
Bells, Extension (Subscriber		Clamps, Guy.....	332	Dowel Pins.....	382
Sets).....	200, 201	Clamps, Span.....	333	Drops.....	86-88
Belts, Tool.....	377	Clamps, Splicing.....	367	Drop Mountings.....	89
Bends, Single Duct.....	382	Clamps, Wire and Sleeve... 368		Drop Spaces.....	89
Binding Posts.....	6	Clay Conduit, Single Duct... 381		Duct Shields, Cable.....	365
Binding Post Chambers... 40, 41		Climber Straps and Pads... 377			
Blankets, Rubber.....	355	Climbers, Pole.....	376	E	
Blocks, Connecting.....	51	Clippers, Bolt.....	371	Elbows, Fibre Conduit..... 381	
Blocks, Fuse.....	92	Clips, Wire Rope.....	329	Electric Clocks.....	11
Blocks, Metal.....	366	Clocks, Calculagraph.....	309	Expansion Bolts.....	378
Blocks, Protector.....	160, 161	Clocks, Chronoscope.....	309	Expansion Shields.....	378, 379
Bolt Clippers.....	371	Clocks, Electric.....	11	Extension Bells (Subscriber	
Bolts, Arming.....	336, 337	Cobs, Wood.....	326	Sets).....	200, 201
Bolts, Carriage.....	338	Coils, Heat.....	115	Extension Ladders.....	363
Bolts, Crossarm.....	338	Coils, Induction.....	116-119	Eye Bolts.....	337
Bolts, Expansion.....	378	Coils, Repeating.....	179, 180		
Bolts, Eye.....	337	Coils, Retardation.....	184-187	F	
Bolts, Guyeye.....	328	Coin Collectors.....	314, 315	Fanning Strips.....	89
Bolts, Screw Eye.....	336	Combined Jacks and Signals.44-46		Fasteners, Cord.....	70
Bolts, Telephone Bracket... 330		Condensers.....	47-49	Fasteners, Jack.....	131
Booth Switches.....	7	Condenser Adapters.....	50	Fibre Conduit.....	380
Booths, Telephone.....	8-10, 308	Condenser Brackets.....	50	Fibre Conduit Bends.....	380
Boxes, Desk Set (Subscriber		Condenser Mountings.....	50	Flags, Metal.....	363
Sets).....	200-211	Condenser Straps.....	50	Folding Barricades.....	365
Boxes, Jack.....	129-131	Conduit, Fibre.....	380	Frames and Covers, Manhole 364	
Braces, Crossarm.....	339	Conduit Bends, Fibre.....	380	Frames, Distributing.....	83-85
Brackets, Condenser.....	50	Conduit Fittings.....	381	Friction Tape.....	385
Brackets, Corner.....	330	Conduit, Multiple Duct... 382		Fuses.....	89-91
Brackets, Distributing.....	330	Conduit, Wood.....	383	Fuse Blocks.....	92
Brackets, Transmitter.....	298	Connecting Blocks.....	51	Fuse Chambers.....	42
Brackets, Transmitter Arm... 298		Connector Batteries.....	7	Fuse Posts.....	92
Brackets, Wood.....	326	Connectors, Line Hose.....	354		
Brush Hooks.....	363	Converters, Frequency.....	319	G	
Buttons, Push.....	163	Cords, Telephone and		Galvanized Wire.....	340
Buzzers, A.C.....	11	Switchboard.....	52-69	Gauges.....	93
C					
Cable Jack, Aerial.....	353	Cord Accessories.....	70	Generators, Hand.....	96-99
Cable Clamps.....	327	Cord Fasteners.....	70	Generator Boxes, Hand... 99	
		Cord Hooks.....	70	Glass Insulators.....	345
		Cord Pulleys.....	70	Glove Bags, Linemen's... 354	
		Cord Tips.....	71-73	Gongs.....	94, 95
		Cord Weights.....	73		

Material	Page	Material	Page	Material	Page
Signs, Warning.....	363	Telephone Aux. Sig. Relay		Trailers and Pole Dinkeys.....	350-352
Single Duct Bends.....	382	Sets.....	313	Transmission Circuits.....	262
Single Duct Clay Conduit.....	381	Telephone Booths.....	8-10, 308	Transmitters.....	293-295
Sleeve Twisters.....	368	Telephone Brackets, Clamps		Transmitter Arms.....	296, 297
Socket Joint Single Duct		and Mountings.....	316-318	Transmitter Arm Brackets.....	298
Conduit.....	381	Telephones, Central Battery		Transmitter Attachments.....	297
Sockets, Lamp.....	147		276-281	Transmitter Brackets.....	298
Spaces, Drop.....	89	Telephones, General.....	259-262	Tree Saws.....	362
Spaces, Jack.....	132	Telephones, Magneto.....	263-275	Tree Trimmers.....	362
Spaces, Key.....	143	Telephones, Mine.....	269-274	Tree Wire Guards.....	331
Span Clamps.....	333	Telephones, Portable Mag-		Trimmers, Tree.....	362
Splicing Clamps.....	367	neto.....	268, 269	Trouble Caps, Plug.....	157
Splicing Tape.....	385	Telephones, Railway.....	275	Troublemen's Blocks.....	370
Spoons, Post Hole.....	360	Telephone Sets, Hand.....	111-114	Truck Bodies.....	346, 347
Straps, Condenser.....	50	Telephone Wire.....	384, 385		
Straps, Safety.....	372	Terminal Punchings.....	282	V	
Street Railway Telephones.....	275	Terminal Strips.....	283	Volt-Ohmmeters.....	384
Strips, Terminal.....	283	Testing Apparatus.....	284-287		
Subscriber Sets.....	200-211	Testing Cabinets.....	286, 287	W	
Switchboards.....	212-256	Test Sets, Portable.....	284, 285	Warning Signs.....	363
Switchboard Cable.....	23-29	Testers, Dial.....	82	Washers, Round or Square.....	339
Switchboards, Central Battery		Thimbles, Guy.....	342	Weights, Cord.....	73
Multiple.....	246-256	Tool Bags.....	370	Winches.....	349
Switchboards, Central Battery		Toll and Telegraph Test-		Wire Cutters.....	371
Non-Multiple.....	224-226	board.....	245	Wire, Distributing Frame.....	299
Switchboards, Magneto Non-		Tool Belts.....	377	Wire, Galvanized.....	340
Multiple.....	215-223	Tool Kits.....	371	Wire, Guy.....	340
Switchboards, P.B.X.....	227-244	Tools, Cable and Cable Ter-		Wire Holders.....	333
Switchboards, P.B.X. Cord-		minal.....	288	Wire, Jumper.....	299
less Type.....	240	Tools, Distributing Frame.....	288	Wire Rope Clips.....	329
Switchboards, Toll and Tele-		Tools, Drop.....	288	Wire and Sleeve Clamps.....	368
graph Test.....	245	Tools, Jack.....	288	Wire, Switchboard.....	299
Switchboard Wire.....	299	Tools, Key.....	289	Wire, Telephone, Telegraph	
Switches, Booth.....	7	Tools, Lamp, Lamp Cap.....	289		384, 385
Switch Hooks.....	257, 258	Tools, Message Register.....	289	Wire Tools.....	292, 373-376
		Tools, Miscellaneous.....	292	Wood Brackets.....	326
T		Tools, Plug.....	289	Wood Cobs.....	326
Take-Up Reels.....	362	Tools, Protector.....	290	Wood Conduit.....	383
Tape, Friction, Splicing.....	385	Tools, Relay.....	290	Wood Crossarms.....	324
Tape, Joint.....	383	Tools, Resistance Coil.....	291	Wood Pins.....	325
Telegraph Wire.....	385	Tools, Ringer.....	291	Wood Poles.....	321-323
Telephone Arms (See Trans-		Tools, Switchboard Cord.....	291	Wood Pole Steps.....	326
mitter Arms)		Tools, Telephone Set.....	292	Wrenches, Lag Screw.....	371
		Tools, Wire.....	292, 373-376	Wrenches, Linemen's.....	371

DISTRIBUTOR IN THE UNITED STATES

Graybar

ELECTRIC COMPANY

Akron
Albany
Asheville
Atlanta
Baltimore
Beaumont
Birmingham
Boston
Brooklyn
Buffalo
Charlotte
Chicago
Cincinnati
Cleveland
Columbus

Dallas
Davenport
Dayton
Denver
Detroit
Duluth
Durham
Flint
Fort Worth
Fresno
Grand Rapids
Hammond
Harrisburg
Hartford
Houston

Indianapolis
Jacksonville
Kansas City
Knoxville
Los Angeles
Louisville
Memphis
Miami
Milwaukee
Minneapolis
Mount Vernon
Nashville
Newark
New Haven
New Orleans

New York (2)
Norfolk
Oakland
Oklahoma City
Omaha
Philadelphia
Phoenix
Pittsburgh
Portland
Providence
Reading
Richmond
Roanoke
Rochester
St. Louis

St. Paul
Salt Lake City
San Antonio
San Francisco
Savannah
Seattle
Spokane
Syracuse
Tacoma
Tampa
Toledo
Washington
Wichita
Worcester
Youngstown

A NATIONAL ELECTRIC SERVICE

DISTRIBUTOR FOR CANADA AND NEWFOUNDLAND

Northern Electric Company LIMITED

General Sales Offices: 1261 Shearer Street, Montreal, P. Q.

Branch Houses

Halifax
Saint John, N. B.
Quebec
Montreal

Ottawa
Toronto
Hamilton
London

Windsor
New Liskeard
Sudbury
Winnipeg

Regina
Calgary
Edmonton
Vancouver

FOREIGN DISTRIBUTORS

International Standard Electric Corporation

67 Broad Street

New York, U. S. A.

Associated, Allied or Affiliated Companies

ARGENTINA

Cia Standard Electric Argentina,
Casilla de Correo 49 (Street Ad-
dress, Defensa 143),
Buenos Aires

AUSTRALIA

Standard Telephones and Cables
(Australasia) Ltd., 71 York Street
(P. O. Box 525-B),
Sydney, N. S. W.

AUSTRIA

United Telephone and Telegraph
Works, Ltd., Dresdner Strasse
No. 75,
Vienna, XX/2

BELGIUM

Bell Telephone Manufacturing Co.,
4 Rue Boudewyns. P. O. Box 526,
Antwerp

BRAZIL

International Standard Electric
Corp., Caixa Postal 480 (Street
Address, Avenida Rio Branco,
99/101),
Rio de Janeiro

CHINA

China Electric Co., Ltd., 240
Kiangse Road (P. O. Box 289),
Shanghai

CZECHOSLOVAKIA

Standard Electric Doms a
Spolecnost, Samova, U 1, 664,
Prague

DENMARK

Standard Electric A/S., Gylden-
lovesgade 1, Copenhagen, V.

EGYPT

Standard Telephones and Cables,
Ltd., Cozika Buildings, Sharia
Solliman Pasha,
Cairo

GERMANY

Standard Elektrizitäts Gesell-
schaft A/G., Genest Strasse 5,
Berlin-Schöneberg

GREAT BRITAIN

Standard Telephones and Cables,
Ltd., Connaught House, 68 Ald-
wych,
London, W. C. 2

HOLLAND

Bell Telephone Manufacturing Co.,
Scheldestraat 160-162,
The Hague

HUNGARY

Standard Electric Co., Ltd.,
Ujpest 4, n. Budapest

INDIA

Standard Telephones and Cables,
Ltd., Block C2, Clive Buildings,
8 Clive Street,
Calcutta

ITALY

Standard Elettrica Italiana, Via
Vittoria Colonna No. 9,
Milan, 125

JAPAN

Nippon Electric Co., Ltd., 2 Mita
Shikokumachi, Shiba-Ku, Tokyo

JAVA

Bell Telephone Manufacturing Co.,
Bureau in Nederlandsch Oost In-
die Riouwstraat, 85,
Bandoeng

NEW ZEALAND

Standard Telephones and Cables
(Australasia) Ltd., 24-26 Ballance
Street, P. O. Box 688,
Wellington

NORWAY

Standard Electric Aktieselskap,
Hovind, Ostre Akre,
Oslo

POLAND

Standard Electric Co. W. Polsce,
Sp. Z.O.O. Wspolna 53, Warsaw

PORTUGAL

Standard Electrica, S.A. Praca
Dos Restauradores 47-1. Lisbon

RUMANIA

Standard Electric Romana, S. A.
37 Calea Victoriei, Bucharest, 1

SOUTH AFRICA

Standard Telephones and Cables,
Ltd., Locarno House, Loveday
Street (P. O. Box 1571),
Johannesburg

SPAIN

Standard Electrica, S/A., Calle
Ramirez de Prado (Post Office
Box 7040),
Madrid

STRAITS SETTLEMENTS

Standard Telephones and Cables,
Ltd., Hongkong Bank Chambers,
Collyer Quay (P. O. Box 558),
Singapore

SWITZERLAND

Bell Telephone Manufacturing Co.,
10 Bubenbergplatz,
Berne

DISTRIBUTOR FOR FRANCE AND FRENCH COLONIES:

Le Materiel Telephonique, 46-47 Quai de Boulogne, Boulogne, Billancourt (Seine) France