

*Western Electric*

**TELEPHONE  
APPARATUS  
AND  
SUPPLIES**

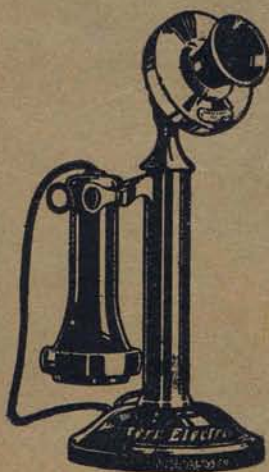

**NO. 3.**

# CATALOG OF TELEPHONE APPARATUS AND SUPPLIES

NO. 3

*Western Electric*

**COMPANY**

*Incorporated*

New York City

---

## DISTRIBUTING HOUSES

### In the United States

NEW YORK, N. Y.  
PHILADELPHIA, PENNA.  
BOSTON, MASS.  
PITTSBURGH, PENNA.  
BUFFALO, N. Y.  
ATLANTA, GA.  
RICHMOND, VA.  
NEW ORLEANS, LA.  
DALLAS, TEXAS  
HOUSTON, TEXAS  
INDIANAPOLIS, IND.  
CINCINNATI, OHIO  
SAINT LOUIS, MO.

CHICAGO, ILLINOIS  
MILWAUKEE, WIS.  
DETROIT, MICH.  
CLEVELAND, OHIO  
MINNEAPOLIS, MINN.  
KANSAS CITY, MO.  
OMAHA, NEBRASKA  
OKLAHOMA CITY, OKLAHOMA  
DENVER, COLORADO  
SALT LAKE CITY, UTAH  
LOS ANGELES, CAL.  
SEATTLE, WASHINGTON  
PORTLAND, OREGON

SAN FRANCISCO, CAL.

---

Copyright, 1916, Western Electric Company, Incorporated

GENERAL OFFICES: 463 WEST STREET, NEW YORK CITY

3-D-16-18-W. E. T.-401



Four Gold Medals—First prizes, highest awards for individual lines.

One Grand Prize—Highest possible award for general excellence for exhibit as a whole.

WESTERN ELECTRIC COMPANY  
AWARDED FOR  
Mine, Telephones and  
Rescue Telephone  
Equipment

WESTERN ELECTRIC COMPANY  
AWARDED FOR  
Comprehensive System of  
Telephone Train Dispatching  
and Control

WESTERN ELECTRIC COMPANY  
AWARDED FOR  
Standard Telephone Switchboard  
Apparatus and Equipment

WESTERN ELECTRIC COMPANY  
AWARDED FOR  
Machinery

WESTERN ELECTRIC COMPANY  
NEW YORK  
HIGHEST AWARD  
FOR  
GENERAL EXCELLENCE OF  
ELECTRICAL MERCHANDISE

PANAMA PACIFIC  
INTERNATIONAL  
EXPOSITION  
SAN FRANCISCO  
1915

PANAMA PACIFIC  
INTERNATIONAL  
EXPOSITION  
SAN FRANCISCO  
1915

PANAMA PACIFIC  
INTERNATIONAL  
EXPOSITION  
SAN FRANCISCO  
1915

PANAMA PACIFIC  
INTERNATIONAL  
EXPOSITION  
SAN FRANCISCO  
1915

OFFICIAL  
AWARD  
RIBBON

OFFICIAL  
AWARD  
RIBBON

OFFICIAL  
AWARD  
RIBBON

OFFICIAL  
AWARD  
RIBBON

GRAND  
PRIZE  
DEPARTMENT OF  
MANUFACTURES AND  
VARIED INDUSTRIES  
CHIEF

GOLD  
MEDAL  
DEPARTMENT OF  
MINES AND  
METALLURGY  
CHIEF

GOLD  
MEDAL  
DEPARTMENT OF  
LIBERAL ARTS  
CHIEF

GOLD  
MEDAL  
DEPARTMENT OF  
LIBERAL ARTS  
CHIEF

GOLD  
MEDAL  
DEPARTMENT OF  
MACHINERY  
CHIEF

Western Electric  
QUALITY PRODUCTS

## FOREWORD

This catalog represents the most advanced ideas in catalog making, and is the most complete exposition of telephone apparatus and supplies ever published.

### Completeness

This catalog lists only the types of equipment which are in common use.

With a line so varying, it is manifestly impossible to show all types and combinations, and while we strongly recommend the use of the standard equipment as shown, yet in case special equipment is necessary, your inquiries are solicited.

### Prices

Western Electric prices are as low as possible consistent with high quality material and expert workmanship. Prices in this catalog have been omitted in certain instances, on account of the fluctuations in the market value of the various raw materials and the many possible alternatives, such as in switchboard equipment.

## THE WESTERN ELECTRIC COMPANY

In the electrical and telephone field there is probably no name so well known as that of the Western Electric Company. This in itself is cause for pride, but of more importance, both from the customer's standpoint and our own, is the reason for such an extended reputation. The Western Electric Company has been engaged in the manufacture of telephone apparatus for more than thirty-eight years.

### Manufacturing

At Hawthorne, Illinois, on the outskirts of Chicago, is located the principal factory of the Western Electric Company. This centralized purchasing of the raw material, manufacturing and testing enables us to produce standard telephone equipment at moderate price.

### Experience

Our experience in the designing, manufacturing and testing of telephone apparatus enables us to offer a complete and attractive line of quality apparatus which has proved its merit. Therefore, our customers avoid experiments with untried apparatus, which may prove costly.

### Permanent Source of Supply

Although the advances of the art has made it necessary for us to develop and market various types of apparatus and equipment, we are prepared to furnish equipment for additions or extensions to the original installations. If the code number is not known, it is advisable to send us samples in order to secure prompt and proper filling of the order. One of the important factors to be considered in the purchasing of telephone apparatus is the certainty of a permanent source of supply for repairs and additional parts.

### Engineering Services

At every Western Electric distributing house there are telephone engineers who will cheerfully render any assistance desired by our customers. The benefit of our long experience as the leading telephone manufacturer is at the disposal of our customers and friends.

### Stocks and Shipments

Each Western Electric distributing house carries a complete stock of telephone apparatus, construction material and tools from which immediate shipments can be made. These distributing houses, located at the strategic business centers, not only insure prompt shipments but a saving in the freight charges, as the prices are F. O. B. the distributing houses.

### Equipment for Every Electrical Need

In addition to manufacturing and marketing a complete line of telephone equipment and supplies, the Western Electric Company furnishes equipment for every electrical need. Information and prices for your requirements will be cheerfully furnished upon request, whether it be for a simple door bell equipment or a large electric lighting plant.

*If it's electrical and practical, we can furnish it.*

Telephone Apparatus and Supplies

THE HAWTHORNE (Illinois) PLANT  
OF THE  
*Western Electric Company*  
INCORPORATED

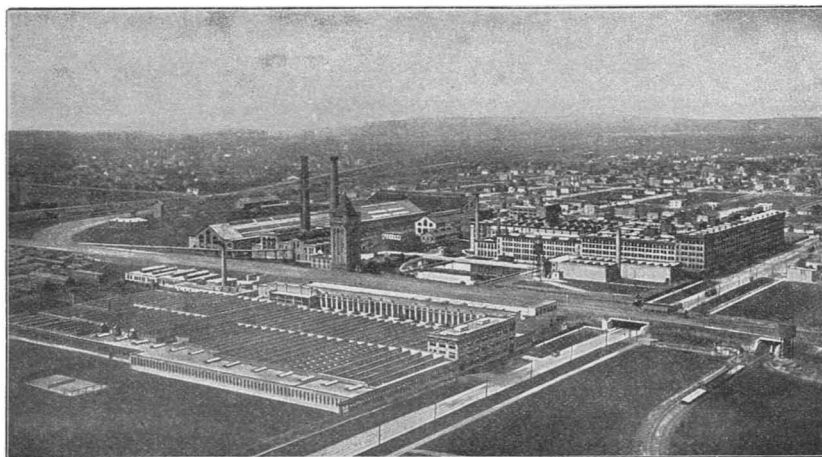

### History

The Western Electric Company was organized in 1881—just five years after Alexander Graham Bell invented the telephone—as the successor of the Western Electric Manufacturing Company, a Chicago firm engaged in the manufacture of telephone apparatus. The Company is the oldest electrical manufacturer in the United States, no other company having been engaged continuously in the production of electrical apparatus for so long a period.

### Factory and Products

Telephones and telephone central office equipment have always been the Company's chief products. Its factory is located at Hawthorne, Ill., six miles from the center of Chicago. This plant covers 211 acres of ground.

Coincident with the extension of its manufacturing facilities, it has developed a distributing organization which now embraces thirty-one houses located at principal business centers in the United States. These houses and their complete stocks assure the very best of service to the customers of the Western Electric Company.

But the Company is more than an American institution. It has an international scope. In Canada, in the principal capitals of Europe, and in Japan are companies manufacturing telephone apparatus in which the Western Electric Company owns an interest, and coupled with this manufacturing organization is a chain of selling offices that carry their products to the entire civilized world.

## IMPORTANT

### TERMS

Terms are thirty days net. All bills are due on the 15th of the following month. Payments may be made by bank draft, post-office or express money order or registered letter. We are not responsible for remittances lost in the mails.

### REFERENCES

New customers, unless satisfactorily rated by the commercial agencies, should send references with their first order and a brief statement of their financial condition. This will enable us to ship promptly.

### C. O. D. SHIPMENTS

To avoid the delay necessarily occasioned by our taking time to make the usual inquiries of references, we are always glad to ship by express C. O. D., or by freight subject to sight draft against bill of lading.

### PRICES

The prices as given in this list are f. o. b. the distributing house, unless otherwise specified, and are subject to change without notice. Other net prices quoted upon request. Please state quantities desired.

### SHIPMENTS

We request customers to give shipping directions with their orders, but if not given we will use our best judgment in making selections of route. As experienced packers are employed, we are not responsible for breakages after having obtained "in good order" receipt from the transportation company. Goods ordered to be shipped by mail will be sent only at purchaser's risk.

### RETURN OF MATERIAL

If for any reason it is desired to return material, first communicate with us and secure shipping instructions. This is necessary to enable us to properly identify the returned shipment.

## Information for Customers Ordering Repair Parts

---

With very few exceptions, all Western Electric apparatus such as drops, generators, keys, ringers, combined jacks and signals, plugs, relays, receivers, transmitters, etc., are plainly marked with a code number.

Customers desiring to order duplicate apparatus or parts of such apparatus will facilitate the proper interpretation of their order by giving the code number of the apparatus for which the repair part is intended. It will further assist us if a sample of the part desired accompanies the order, at the same time giving code number of the piece of apparatus involved.

## WESTERN ELECTRIC COÖPERATIVE SERVICE

### Rural Telephones

The Western Electric Company's slogan, "A telephone on every farm," includes a plan to provide "Sales Helps" for those engaged in the resale of Western Electric telephones and supplies, and "Service Helps" for telephone companies wishing to stimulate a desire for telephone service and so increase the number of their subscribers.

The attractive helps listed on the following pages have been prepared to assist our customers.

They will be furnished absolutely free of charge.

As a further aid in this work, the Western Electric Company carries on a continuous and extensive advertising campaign in farm papers.

### Adjustable Telephone Brackets and Inter-phones

To those seeking to increase their sales of Adjustable Telephone Brackets and Inter-phones there is offered an unusually attractive array of Sales Helps. These sales helps are also listed on the following pages and are all furnished free of charge.

The Western Electric Company, in line with its policy of full coöperation with its customers, is ready at all times to aid in the preparation of business-pulling sales helps for any special drive the dealer may be planning.

If the helps listed in the following pages do not meet with your ideas and local conditions, tell us and we will promptly prepare advertisements especially designed for your use.

## SERVICE HELPS FOR TELEPHONE COMPANIES

Any or all of the service helps catalogued in the following pages will be furnished—FREE—to telephone companies that desire to get new subscribers and increase their business through advertising.

The newspaper ads. have space for name and address—lantern slides, booklets and postcards will be imprinted with company's name where desired.

Order by number.

### Newspaper Printing Plates



**IF ACCIDENT OR SICKNESS SHOULD SURPRISE YOU, HOW FAR IS THE DOCTOR???**

With a telephone in your home he is in the next room. This means prompt assistance, relief from pain, life saved. Are you going to let another day go by without a telephone in your home?

Why take chances? The cost is trifling the service is your- priceless.

Drop a card today to

*[Your Name and Address Here]*

and have a representative call and tell you how little it costs to have a telephone in your house.

**Western Electric**  
TELEPHONES  
guarantee you best service.

**TR-7**  
Single Column  
6 3/4 Ins. High



**HOW FAR AWAY IS YOUR NEAREST NEIGHBOR??**

One great use of the telephone on the farm is that it gives **COMPANIONSHIP** . . . . . It brings your friends to you, takes you to them, no matter how far away they may live. It summons help in an emergency. . . . .

It is the company for the birthday, wedding, and other anniversaries dear to every home.

Add back of these announcements is that other great opportunity. . . . .

Don't hold back any longer drop a card today to

*[Your Name and Address Here]*

and a representative will call to explain how very little it costs to have this service.

**Western Electric**  
TELEPHONES  
guarantee you best service.

**TR-8**  
Single Column  
7 1/2 Ins. High



**FROST IS DUE TOMORROW ARE YOU PREPARED?**

Telephone to your newspaper today for tomorrow's weather predictions

*[Your Name and Address Here]* will install a phone—you do the rest. Don't Gamble.

Better drop a card today and have a representative call and tell you how little it costs to have a telephone in your home.

**Western Electric**  
TELEPHONES  
guarantee you best service.



**TR-9**  
Single Column  
6 3/4 Ins. High

**Which Man Are You?**

The man who must hitch up and drive to conduct business. Make special calls. Expense high in comparison. Do you know how to get the man and what the right price for a card today because you are not better served with the driver.



Do you need your "ride" over the telephone just there?

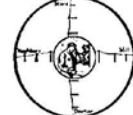

The man who must hitch up and drive to conduct business. Make special calls. Expense high in comparison. Do you know how to get the man and what the right price for a card today because you are not better served with the driver.

*[Your Name and Address Here]*

and have a representative call and tell you how little it costs to have a telephone in your home.

**Western Electric**  
TELEPHONES  
guarantee you best service.

**TR-10**  
Single Column  
7 Ins. High

### Lantern Slides



**LS-600**  
Telephone Apparatus and Supplies

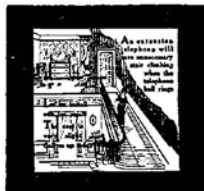

**LS-602**  
8



**LS-603**

## RURAL SERVICE HELPS FOR TELEPHONE COMPANIES

### Small Folders



BR-205



BR-206

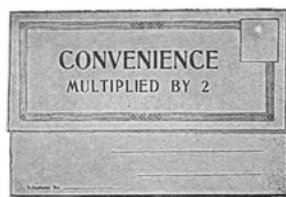

B-150

### Post Cards

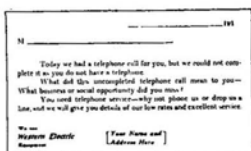

SH-15

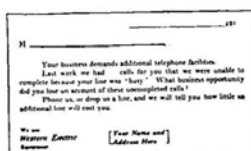

SH-16



SH-17

### Electrotypes

for Bill Heads, Letter Heads, etc.



TC-3



TC-4

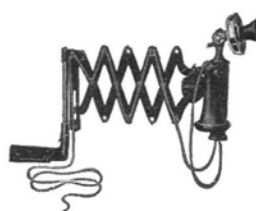

TC-6

Specify size desired—also furnish sample of paper on which electrotypes are to be used to obtain plates that will give the best printing results.

## SALES HELPS RURAL TELEPHONE

Any or all of the service helps catalogued under this head will be furnished—FREE—to distributors of rural telephones and supplies, who desire to organize new telephone lines and increase the demand for telephone service in their territory.

Order by number.

### Newspaper Printing Plates



**IF ACCIDENT OR SICKNESS SHOULD STRIKE YOURS, HOW FAR IS THE DOCTOR???**  
With a telephone in your home he is in the next room. This means prompt assistance, relief from pain, life saved. Are you going to let another day go by without a telephone in your home?

Why take chances? The cost is trifling, the service to you—priceless. Drop a card today to

[Your Name and Address Here]

and have a representative call and tell you how little it costs to have a telephone in your house.

**Western Electric**  
TELEPHONES  
guarantee you best service.

**TR-7**  
Single Column  
6½ Inches High



**HOW FAR AWAY IS YOUR NEAREST NEIGHBOR???**

One great use of the telephone on the farm is that it gives COMPANIONSHIP. . . . . It brings your friends to you, takes you to them, no matter how far away they may live. It summons help in an emergency.

It invites company for the birthday, wedding, and other occasions dear to every home. And back of these conveniences is that other great use—

**BUSINESS** . . . . . Don't hold back any longer, drop a card today to

[Your Name and Address Here]

and a representative will call to explain how very little it costs to have this service.

**Western Electric**  
TELEPHONES  
guarantee you best service.

**TR-8**  
Single Column  
6½ Inches High



**FROST IS DUE TOMORROW ARE YOU PREPARED?**

Telephone to your newspaper today for tomorrow's weather predictions.

[Your Name and Address Here] will install a phone—you do the rest. Don't gamble.

Better drop a card today and have a representative call and tell you how little it costs to have a telephone in your home.

**Western Electric**  
TELEPHONES  
guarantee you best service.

**TR-9**  
Single Column  
7 Inches High

**Which Man Are You?**  
The man who smokes 20 and drives his tractor, makes it more than a mere machine. Do you have time to the road and when the highest prices for your crops because you are not in close touch with the market?



Or do you send your wife over the telephone to do these things?



The man who has a telephone has a big business. If you are that man, drop a card today to

[Your Name and Address Here] and have a representative call you how little a telephone will cost you.

**Western Electric**  
TELEPHONES  
guarantee you best service.

**TR-10**  
Single Column  
7 Inches High

### Metal Hanger



13¼ Inches x 19¼ Inches—in colors

### Lantern Slides



**LS-600**  
Telephone Apparatus and Supplies



**LS-604**  
10

SALES HELPS  
 RURAL TELEPHONE  
 Small Folders



BR-200



BR-201



BR-202



BR-208

Booklets



BR-203



BR-204

Printing Plates  
 for  
 Billheads, Letterheads, etc.



TC-3

Specify size desired. Also furnish sample of paper on which electrotypes are to be used to obtain plates that will give the best printing results.



TC-4

Telephone Apparatus and Supplies

**CITY SERVICE HELPS  
FOR TELEPHONE COMPANIES  
Small Folders Post Cards**



SH-21

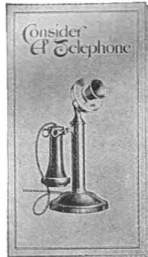

SH-22



SH-19

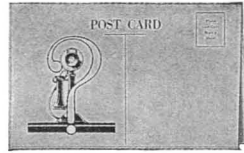

SH-20  
(See B-150, SH-15, SH-16 and SH-17 on page 9)

**Newspaper Electrotypes (Double Column)**

Shop from Home—By Telephone

No more weary trudging from place to place. The telephone brings the butcher, the baker, the department store and every other shop to your home. In rain—in sunshine—in snow—the telephone is always ready to do your bidding. This service would be cheap to you at any price. A telephone in your home costs so little—you can not afford to be without it. Ask today—let us explain how little a telephone really costs.

(Imprint Name Here)

CE-22  
7 Inches High

**Lantern Slides**



LS-605



LS-606



LS-607

**Telephone Apparatus and Supplies**

Back of Every Home—A Telephone!

There should be a telephone in every home—"Backing it up" with its dependability—against emergencies—against hardships—against fear. When sudden accidents—the telephone summons the doctor quicker than any known agency—it brings help that prolongs life. When thieves break in to steal—it summons the police—at once. When fire breaks out—our men in immediate touch with the fire department. Home-possessions—lives—are saved. Truly—the telephone is the guardian of the home! Don't delay putting a telephone in your home. It means so much—costs so little! Ask today for details.

(Imprint Name Here)

SH-23  
5½ Inches High

**Newspaper Electrotypes (Single Column)**

Rain—Rain Go Away!

You never say that when you have a telephone in your home—it isn't necessary. A telephone knows no weather—no frost—no hardship. Rain or snow—day or night—it's always ready to take your voice where you would otherwise have to go yourself. Think of the convenience—and the cost is so small—it is surprising. A postal brings complete information. Send it today!

(Imprint Name Here)

CE-20  
7 Inches High

Hello!

I have a telephone in my home! Have You?

It's the handiest thing around our house. We can talk to almost anybody in town—any time. It saves trips and time and offers the surest protection against burglars, fire and sickness. No, it's not expensive. It's the cheapest, best thing you can get—Do it today!

(Imprint Name Here)

CE-21  
7 Inches High

SALES HELPS

ADJUSTABLE TELEPHONE BRACKETS

The various helps catalogued below will be imprinted with the name of the telephone company or agent.

Newspaper  
Printing Plate



Single Column  
6 Inches High

Lantern Slide



LS-534

Printing Plate for  
Billheads, etc.

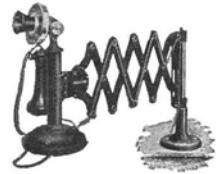

TC-5

Window Display

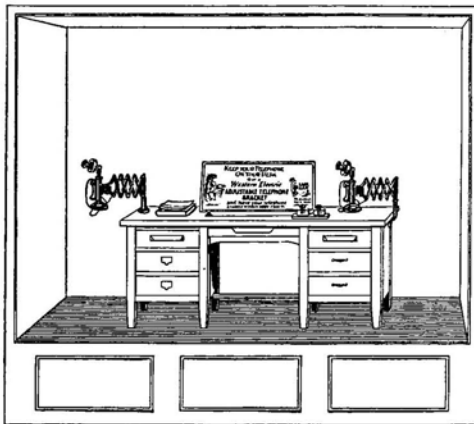

W-22

Window Card

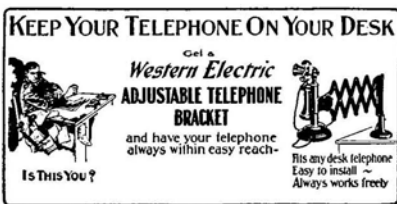

C-705

Small Folder

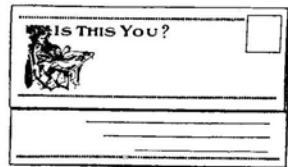

B-152

Telephone Apparatus and Supplies

SALES HELPS  
INTER-PHONES

The various helps catalogued on this and the following page will be furnished FREE to agents handling the Inter-phone line. They will be imprinted with the name of the agent.

Order by number.

Newspaper Printing Plates



T-220  
Single Column  
3½ Inches High



T-221  
Single Column  
3½ Inches High



T-222  
Single Column  
6 Inches High



T-223  
Single Column  
6 Inches High



T-224  
Double Column  
6 Inches High

Window Display



**SALES HELPS  
INTER-PHONES**

**Lantern Slides**



LS-535



LS-536



LS-537

**Small Folder**

**Window Card**



C-706



B-111

**APPARATUS BLANKS**



These are intended for covering apparatus drillings in switchboards, telephones, etc., which are not originally equipped with apparatus or from which apparatus has been removed for some reason.

We manufacture a complete line to suit every requirement. Information will be cheerfully furnished on request.

**APPARATUS BOXES**

**NON-FLUSH, NO. 383 TYPE**



No. 383. Non-flush Apparatus Box

Cover Removed

Non-flush boxes for use with No. 1003 type hand sets in Inter-phone service. Consists of an insulating base on which are mounted the connecting terminals, signal buzzer and other necessary apparatus, over which is placed a pressed metal cover finished in black. Hand set hook is nickel finish.

Dimensions, 3 1/4 inches diameter by 1 1/8 inches deep.

Code No.	Used in Inter-phone Sets	Used with System No.	List Price Each
383A	6043A	15	\$6.30
383B	6043B	15	5.10
383C	6043C and J	16	1.90
383D	6043D and H	16	3.70
383E	6043E	12	5.10
383G	6043G	7, 8, 9 and 10	5.10

**FLUSH, NO. 382 TYPE**

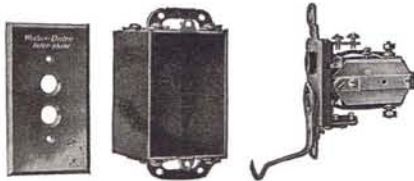

Face Plate No. 12007

Wall Box Type "AA"

Apparatus Unit No. 382 Type

Consists of an apparatus unit, No. 382, to which are fastened the connecting terminals, signal buzzer and other apparatus used in connection with No. 1003 type hand sets in Inter-phone service, a Type "AA" Union Sectional Switch Box and a face plate No. 12007 used when it is desired to mount this apparatus. The switch box and face plate are not included with the apparatus unit.

The wall box and face plate are similar to those used for push button electric light switches, and if desired the apparatus unit only can be ordered, the electrical contractor drawing from his regular stock for the wall box and face plate.

This practice in general, however, is not recommended.

Dimensions of face plate, 2 3/8 inches wide by 4 1/2 inches high.

Code No.	Used in Inter-phones	Used in System No.	List Price Each
382AB	6042H	15	\$7.30
382BB	6042J	15	6.20
382CB	6042R and T	16	2.40
382DB	6042M and P	16	4.10
382EB	6042K	12	6.20
382GB	6042L and W	7, 8, 9 and 10	6.20

## BACKBOARDS

Code No.	Description	Dimensions Inches	List Price Each
79	Wood, black finish. Used with Nos. 12 and 58 type protectors . . . . .	12½ x 5 x 1½	request
136B	Wood, oak finish. Arranged with battery box for 3 dry cells. Used with Nos. 1293 and 1305 type telephone sets . . . . .	26 x 8½ x 7½	\$2.40
138B	Wood, oak finish. Arranged with battery box for 3 dry cells. Used with No. 1240 type telephone sets . . . . .	30½ x 8½ x 7½	2.50
139A	Cast iron bracket, black finish. Used to support No. 50A coin collector on a horizontal surface . . . . .	18½ x 8 x 7½	3.70
140A	Wood, oak finish. Arranged with battery box for 3 wet cells. Used with No. 1305 telephone set . . . . .	31½ x 17¼ x 8½	7.40
141A	Wood, black finish. Used with No. 1333 type telephone sets and No. 334 type desk set boxes . . . . .	8¼ x 6½ x 1	.30
142A	Wood, black finish. Used with No. 1333 type telephone sets when equipped with No. 143A backboard . . . . .	16¾ x 6½ x 1	.80
143A	Metal, black finish, with shelf attachment. Used with No. 1333 type telephone sets . . . . .	8½ x 7½ x 6¾	1.10
144A	Wood, black finish. For mounting a No. 50 type coin collector and a No. 334 metal desk set box where it is desired to insulate this apparatus for the wall . . . . .	27 x 5½ x 1½	request



No. 138B

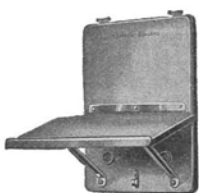

No. 143A



Regular



Screw Top

## DRY BATTERIES

### Western Electric Blue Bell Dry Batteries

There are no conditions under which dry batteries are used where reliability, high efficiency and long life are of greater importance than those met in telephone service.

A general service battery will not stand up under the severe conditions required of a battery for telephone use.

The Western Electric Blue Bell Battery was designed by the best telephone engineers in the country, especially for telephone transmitter work, to meet the need for a reliable, highly efficient and long-lived cell.

It is furnished in three styles of tops: Fahnestock clip top, combination screw top and binding post, and straight screw top. The two latter types are for use in Patterson Battery Sets.

*Sizes of Zinc Cans	Description	Wt. per Cell	No. in Bbl.	Wt. of Bbl. Lbs.	List Price Each	per Bbl.†
2½ x 6	†Standard Fahnestock clip top . . . . .	2	125	300	\$0.70	\$60.00
2½ x 6	Combination screw top and binding post . . . . .	2	125	300	.78	70.00
2½ x 6	Screw top (no binding posts) . . . . .	2	125	300	.76	67.50

\*Add 1 inch to the height of cells having extended carbon plugs, and ½ inch for other styles of connection.

†Screw binding posts will be furnished when specified without extra charge.

‡Delivery F. O. B. Cleveland, Cincinnati, Brooklyn and New York. For warehouse deliveries write nearest house.

**DRY BATTERIES**

**Red Label Blue Bell Dry Batteries**



**Red Label Regular Square Carton**



**Red Label Regular Round Carton**

This cell is designed for a wide range of service; it is a general purpose battery that may be successfully used for all classes of intermittent service, such as door bells, annunciators, railway train dispatching, ignition, etc.

The regular round type is furnished in four styles of tops; standard binding post top, Fahnestock clip top, combination screw top and binding post and straight screw top. The two latter types are for use in Patterson Battery Sets.



**Oval Columbia Cell**

*Sizes of Zinc Cans	Description	Wt. per Cell Lbs.	No. in Bbls.	Wt. of Bbl. Lbs.	—List Price—	
					Each	Per Bbl.†
2½ x 6	†Standard binding post top (round carton) . . . . .	2	125	300	\$0.70	\$80.00
2½ x 6	†Standard binding post (square carton) . . . . .	2	125	300	.70	60.00
2½ x 6	†Combination screw top and binding post . . . . .	2	125	300	.78	70.00
2½ x 6	†Screw top (no binding posts) . . . . .	2	125	300	.76	77.50

\*Add 1 inch to the height of cells having extended carbon plugs, and ½ inch for other styles of connection.

†NOTE: Fahnestock clips will be furnished when specified without extra charge.

†Delivery F. O. B. Cleveland, Cincinnati, Brooklyn and New York. For warehouse deliveries write nearest house.

**Oval Columbia Cells**

**For Portable Telephones**

For use with portable telephones. This cell is equipped with screw binding posts.

List No.	Size of Zinc Cans Ins.	Wt. per Cell Oz.	Wt. per 100 Packed	—List Price—	
				Each	Per 100
0-4	1¼ x 2¼ x 4	11¼	80	\$0.50	\$36.00

**“Eveready” Guaranteed Tungsten Battery**

**For No. 1017 Type Test Sets**

List No.	No. of Cells	—Size Over All—			List Price Each
		Height Ins.	Width Ins.	Depth Ins.	
703	3	2½	2⅞	⅞	\$0.48



**Eveready Battery**

**For No. 1332 Portable Telephones**

792	2	1	2½	3⅞	\$0.48
-----	---	---	----	----	--------

**Silver Chloride Testing Battery**

The chloride of silver cell has the advantage over the ordinary dry cell of not deteriorating as a result of not being used, constant electromotive force and minute size. Each cell will give between .8 and .9 of a volt. A battery of these cells forms a valuable adjunct for a testing equipment. Any individual cell or the total number can be placed in the circuit. The 100 cell battery measures 2 in. x 8 in. x 6 in.

List No.	No. of Cells	††List Price Each
T-2090	100	\$160.00
T-2089	75	128.50
T-2088	50	88.00
T-2087	30	56.00
T-2086	15	32.00
Single cells, each . . . . .		1.60

††Delivery F. O. B. Factory, Philadelphia, Pa. For warehouse deliveries write nearest house.



**100 Cell Silver Chloride Testing Battery Telephone Apparatus and Supplies**

## LIQUID BATTERIES

### No. 2 Samson Battery

Size Over All 8 x 4 3/4 x 4 3/4 Inches

This is regular or circular zinc form of battery. The cell has a voltage of from 1.40 to 1.47, and an amperage on short circuit of from 12 to 16 amperes. This cell is adapted for gas lighting, telephone, gas engines, railway signals, and all special work requiring a battery having great initial strength and capable of quick recovery after hard work.



No. 2 Samson Battery

#### List Prices and Data

Description	Std. Pkg.	*List Price	Description	Std. Pkg.	*List Price
Complete regular	50	\$2.00	Jar	50	\$0.20
Carbon	50	1.30	Sal Ammoniac	200	.15
Cover	100	.16	Zinc regular	100	On request
			Star Fender No. 2	200	.10

## Standard Gravity Batteries



Gravity Battery

Description	Std. Pkg.	*List Price
Cell, complete	5 x 7	\$0.72
Jar, glass, 5 x 7		.28
Zinc		On request
Copper		On request
Cell, complete	6 x 8	\$0.90
Jar, glass, 6 x 8		.32
Zinc		On request
Copper		On request

Blue vitriol not included in above. Prices below.

## BATTERY SUPPLIES



Pencil Zinc



Crowfoot Zinc—6 x 8

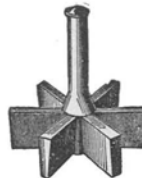

Star Zinc

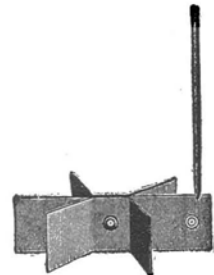

Battery Copper

### Battery Zincs

Description	Std. Pkg.	Lbs. per 100	List Price Each
Crowfoot Zinc, for 5 x 7 in. jar	100	175	On request
Crowfoot Zinc, for 6 x 8 in. jar	50	300	
Crowfoot Zinc, for 6 x 8 in. jar	50	325	
Star Zinc	100	300	On request
Square Pencil Zinc with Copper Binding Screw	500	85	
Round Pencil Zinc	500	85	On request



Blue Vitriol



Sal Ammoniac

### Battery Coppers

Description	Std. Pkg.	Wt. per Pkg. Lbs.	List Price Each
Battery Copper, for 5 x 7 in. jar	500	50	\$0.19
Battery Copper, for 6 x 8 in. jar	500	62	.20

### Blue Vitriol

Description	Approx. Lbs. per Bbl.	List Price per Lb.
Blue Vitriol, Star brand	450	\$0.30

### Sal Ammoniac

Sal Ammoniac (extra quality), bbl. lots, per lb.	525	\$0.20
Sal Ammoniac (extra quality), per 5 oz. package		.10

**BATTERY CONNECTORS**



**Bull Dog Connector**

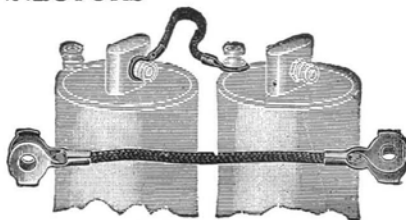

**Sta-There Connector**

**Bull Dog Connectors**

Bull Dog Battery Connectors never let go. They dispense with thumb nuts and all troubles caused by loose battery connections. Snapped on in a second and as easily removed. Cannot shake loose. The cable is stripped and securely soldered to the nickel-plated copper clips. Guaranteed to give perfect contact with minimum resistance.

List No.		No. in Carton	List Price Each
1026	Bull Dog Connector, Phosphor Bronze Terminals, Nickel Plated.....	10	\$0.07
1025	Bull Dog Connector, Spring Brass Terminals, Brass Dipped.....	10	.06

**Sta-There Battery Connector**

**Spring Clip Type**

The use of this device insures permanent and perfect electrical connection between batteries at all times.

It is placed in position by pressing the spring clips together and placing same over the binding screws. The spring contacts are of phosphor bronze and are securely fastened to the conductor cord.

Sta-There Battery Connector.....	List Price Each	<b>\$0.06</b>
----------------------------------	-----------------	---------------

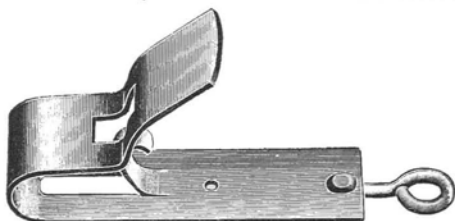

**No. 33**



**No. 155**

**No. 33 Connector**

Temporary connector for emergency work and test sets. Will snap over a No. 8 B. W. G. wire.

List No.		List Price Each
33	Temporary Connector.....	\$0.20

**No. 155 Connector**

This is a spring connecting device intended for use in connecting dry batteries that are equipped with screw and nut binding posts.

To operate it is only necessary to remove the nuts and snap the spring clip over the screws with which they make a firm and jar proof contact.

List No.		List Price Each
155	No. 155 Connector.....	\$0.06

**Western Electric No. 540 Cord**

A stranded conductor battery connector with a moisture-proofed cotton insulation for use in connecting dry cells equipped with Fahnestock clips.

Code No.	Description	List Price per 100
540	Standard length 5 inches. Insulation on each end cut back $\frac{5}{8}$ inch, and the bare conductor soldered to prevent fraying.....	\$1.20



**Plain Connector**



**Link Connector**

**Plain Battery Connector**

Consists of 5 inches of lamp cord, composed of several strands of copper wire, with copper terminals on each end.

List No.		List Price Each
16357	Plain Battery Connector.....	\$0.10

**Link Battery Connector**

Quick-Action Battery Connector.....	List Price Each	<b>\$0.02</b>
-------------------------------------	-----------------	---------------

Telephone Apparatus and Supplies

## EDISON PRIMARY BATTERIES

Edison primary cells are made up in capacities from 150 to 600 ampere hours. They are suitable for circuits in which the flow of current is either continuous or intermittent; there is no deterioration while the battery is idle and no attention required between renewal periods. The No. 403 type is recommended for operating our No. 84 type interrupters.



Type No. 208



Type No. 305



Type No. 403



Type BB



Type Q



Type RR

### BSCO Type

#### RENEWALS AND SEPARATE PARTS

Description	List Prices			
	208	305	305	403
Mfr's. No. ....	208	305	305	403
Type of Jar. ....	Porc.	Porc.	Glass	Porc.
Capacity, ampere hours. ....	200	300	300	400
Complete cell. ....	\$3.74	\$5.10	\$5.44	\$6.12
Complete renewal. ....	2.56	3.06	3.06	3.57

#### Renewal Parts

Zinc-oxide, assembled. ....	\$2.38	\$2.90	\$2.90	\$3.40
1 can caustic soda. ....	.28	.34	.34	.42
1 bottle special battery oil. ....	.11	.11	.11	.11

#### Permanent Parts

Porcelain jar, round. ....	\$1.02	\$1.70		\$2.04
Heat resisting glass jar, round. ....			\$2.04	
Porcelain cover. ....	.60	.77	.77	.86
One set nuts and washers for binding post, per cell. ....	.44	.44	.44	.44

#### Miscellaneous Separate Parts

Description	List Price Each
Large wing nuts, each. ....	\$0.17
Brass washers, each. ....	.09
Hexagon jamb nuts, each. ....	.09
Double connectors, each. ....	.17

#### Dimensions

Type	Size Overall	Jar Only, Inside Dimensions
Type 208	6 x 9 ins.	5 x 7 1/2 ins.
Type 305	6 3/4 x 10 1/4 ins.	6 x 8 ins.
Type 403	7 1/2 x 10 3/4 ins.	6 5/8 x 8 3/4 ins.

### Old Types

#### RENEWALS AND SEPARATE PARTS

Description	List Prices		
	BB	Q	RR
Type. ....	100	150	300
Capacity, ampere hours. ....			
Complete cell. ....	\$3.40	\$3.74	\$5.62
Complete renewal. ....	1.54	1.70	2.90

#### Renewal Parts

1 copper-oxide plate. ....	\$0.68	\$0.86	\$1.46
1 charging zinc plate or plates. ....	.68	.68	1.20
1 can caustic soda. ....	.24	.28	.42
1 bottle special battery oil. ....	.09	.11	.11

#### Permanent Parts

Porcelain jar. ....	\$0.86	\$1.02	\$1.70
Porcelain cover. ....	.43	.60	.86
Copper frames complete with nuts and insulators. ....	.77	.77	.77
Long brass bolt and nuts for zincs. ....		.26	.26

#### Miscellaneous Separate Parts

Description	List Price Each
Copper frame sides (2 per cell). ....	\$0.34
Copper frame bolts and nuts. ....	.17
Hard rubber insulators. ....	.09
Nuts, all sizes. ....	.09

STORAGE BATTERIES

“Chloride Accumulator”

Two-Plate Type

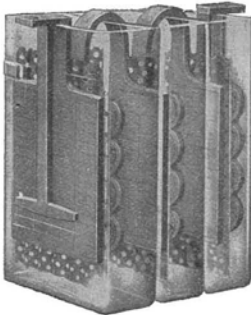

Type "BT"

This type of the “Chloride Accumulator” is especially suitable for service where only a small capacity is required. The positive plate of one cell and the negative plate of the adjacent cell are fused to one connecting strap and the pair are supported on the edges of the two adjacent glass jars.

By this method no connecting bolts or burning are required to install any number of cells in a group, and there are no contacts to corrode or become loose.

These cells have demonstrated their superiority for telephone, telegraph, police and fire alarm signaling, laboratory, experimental service, etc.

The resistance between cells is practically eliminated—this feature being an item of importance in cells of small capacity.

INDIVIDUAL CELLS

Manufacturer's Designation	BT	CT	PT	ET
Discharge in amperes	{ For 8 hours	1½	3	4½
	{ For 5 hours	1	2	4¼
	{ For 3 hours	1½	3	6
Normal charging rate in amperes		¾	1½	3
		¾	1½	3
		¾	1½	3
Outside dimensions of glass jars	{ Length	3¼	6¼	6
	{ Width	6¾	8	12
	{ Height	6¾	8	12
Weight of electrolyte required for one cell	1	2¼	4½	5½
Weight of complete cell, including electrolyte	3½	7½	13½	22

COMPLETE OUTFITS FOR TELEPHONE SERVICE

The following outfits cover complete equipment including accessories as described for 1 and 2 sets of 11 storage cells each, with the exception of glass covers.

Mfr's. Designation	BT		CT		PT		ET	
	11 Cells (1 Set)	22 Cells (2 Sets)	11 Cells (1 Set)	22 Cells (2 Sets)	11 Cells (1 Set)	22 Cells (2 Sets)	11 Cells (1 Set)	22 Cells (2 Sets)
	No.	No.	No.	No.	No.	No.	No.	No.
“Elements” or “couples”	10	20	10	20	10	20	10	20
Positive terminal plates	1	2	1	2	1	2	1	2
Negative terminal plates	1	2	1	2	1	2	1	2
Glass jars (1 extra)	12	23	12	23	12	23	12	23
Glass insulators Type F	6	6	6	6	6	6	6	6
Bolt connectors Type D	3	5		5		5		5
Bolt connectors Type B			3		3		3	
Bolt connectors Type E	1	1	1	1				
Hydrometer Type B					1	1	1	1
Hydrometer Type E								
Floating mercury thermometer with specific gravity temperature correction scale	1	1	1	1	1	1	1	1
Terminal lugs, lead coated. E.S.B. Co.'s drawing D-896 drilled for 1 No. 10 B.&S. wire	1	2	1	2	1	2	1	2
Terminal lugs, lead coated. E.S.B. Co.'s drawing D-1595 Fig. 2, drilled for 3 No. 10 B.&S. wires	1	1	1	1	1	1	1	1
Terminal lugs, lead coated. E.S.B. Co.'s drawing D-1595 Fig. 1, drilled for 2 No. 10 B.&S. wires		1		1		1		1
Electrolyte (specific gravity 1.210) lbs.	20	30	30	60	60	120	70	140
Set of instructions E.S.B.Co.'s Form 421 R-6	1	1	1	1	1	1	1	1

Glass Covers

Glass covers are not listed in the above outfits. If desired, however, they can be furnished when specified.

Sand Trays

Sand trays, although usually furnished with the battery cabinets, can be furnished separately when specified.

METHOD OF ORDERING

Orders for complete storage battery outfits of the above described types should read as follows:

1 complete (1) cell type “\_\_\_\_\_” storage battery outfit including accessories (except glass covers) as described on page 22 of your Telephone Catalog No. 3.

Telephone Apparatus and Supplies

**STORAGE BATTERIES**

**"Chloride Accumulator"**

**Type D**

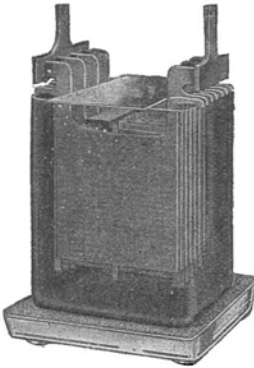

The Type D comprises cells ranging in capacity from 7½ to 15 ampere hours at the normal eight-hour discharge rate.

They are supplied in either glass or hard rubber jars, but inasmuch as glass jars are commonly used for telephone purposes we list below dimensions for glass jars only. In ordering elements, or parts thereof, specify whether intended for glass or rubber jars.

**Type D-7**

**INDIVIDUAL CELLS**

Manufacturer's Designation	D-7	D-9	D-11	D-13
Discharge in amperes { For 8 hours	7½	10	12½	15
{ For 5 hours	10½	14	17½	21
{ For 3 hours	15	20	25	30
Normal charging rate in amperes	7½	10	12½	15
Outside dimensions of glass jar, inches	Length	8¾	9½	11
	Width	7¾	7¾	7¾
	Height	10¾	10¾	10¾
Weight, electrolyte in glass jar, lbs.	14¾	17½	20	24
Weight of cell complete with electrolyte in glass jar, lbs.	42¾	53½	62½	74¾
Height to top of lug, inches	15¾	15¾	15¾	15¾

**COMPLETE (11 CELL) OUTFITS FOR TELEPHONE SERVICE**

The following outfits cover complete equipment including accessories (with the exception of glass covers) for an 11 cell telephone battery, and include the following:

- |                         |                            |
|-------------------------|----------------------------|
| 11 Complete Elements    | Bolt Connectors            |
| 12 Glass Jars (1 extra) | Terminals                  |
| 5 Extra Wood Separators | Displacement Block         |
| 1 Hydrometer            | Electrolyte                |
| 1 Thermometer           | Sand Trays                 |
|                         | 46 Type F Glass Insulators |

Size of Jars	Amperes (Ultimate of Jars) 8 Hour Discharge Rate	Approx. Shipping Weight, Lbs.
<b>11 D-7 Elements (7½ Ampere 8 Hour Discharge Rate) Placed in D-7, D-9, D-11 or D-13 Glass Jars</b>		
D-7	7½	600
D-9	10	800
D-11	12½	900
D-13	15	1000
<b>11 D-9 Elements (10 Ampere 8 Hour Discharge Rate) Placed in D-9, D-11 or D-13 Glass Jars</b>		
D-9	10	800
D-11	12½	900
D-13	15	1000
<b>11 D-11 Elements (12½ Ampere 8 Hour Discharge Rate) Placed in D-11 or D-13 Glass Jars</b>		
D-11	12½	900
D-13	15	1000
<b>11 D-13 Elements (15 Ampere 8 Hour Discharge Rate) Placed in D-13 Glass Jars</b>		
D-13	15	1000

NOTE: If Type D battery is to be in two rows, specify this fact in order.

**Glass Covers**

Glass covers are not included in the above outfits. If desired, however, they can be furnished when specified.

**METHOD OF ORDERING**

Orders for complete storage battery outfits of the above described type should read as follows:  
One complete Type D storage battery outfit including accessories (except glass covers), consisting of 11 D- (give size) elements placed in D- (give size) glass jars, as described on page 23 of your telephone catalog No. 3.

**STORAGE BATTERIES**

**"Chloride Accumulator"**

**Type E**

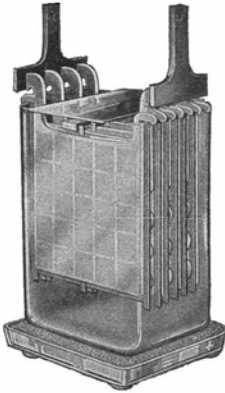

Type E-7

The Type E comprises cells ranging in capacity from 10 to 35 ampere hours at the normal eight-hour discharge rate.

They are supplied in either glass or hard rubber jars, but inasmuch as glass jars are commonly used for telephone purposes we list below dimensions for glass jars only. In ordering elements, or parts thereof, specify whether intended for glass or rubber jars.

**INDIVIDUAL CELLS**

Manufacturers' Designation	E-5	E-7	E-9	E-11	E-13	E-15	
Discharge in amperes {	For 8 hours.....	10	15	20	25	30	35
	For 5 hours.....	14	21	28	35	42	49
	For 3 hours.....	20	30	40	50	60	70
Normal charging rate in amperes.....	10	15	20	25	30	35	
Outside dimensions of glass jar, inches.....	Length.....	5 $\frac{3}{4}$	6 $\frac{3}{4}$	8 $\frac{1}{4}$	9 $\frac{1}{2}$	11	12 $\frac{1}{4}$
	Width.....	9 $\frac{1}{4}$	9 $\frac{1}{4}$	9 $\frac{3}{4}$	9 $\frac{3}{4}$	9 $\frac{3}{4}$	9 $\frac{3}{4}$
	Height.....	12 $\frac{3}{4}$	12 $\frac{3}{4}$	12 $\frac{3}{4}$	12 $\frac{3}{4}$	12 $\frac{3}{4}$	12 $\frac{3}{4}$
Height of cell from bottom of glass jar to top of strap, inches.....	17 $\frac{3}{4}$	17 $\frac{3}{4}$	17 $\frac{3}{4}$	17 $\frac{3}{4}$	17 $\frac{3}{4}$	17 $\frac{3}{4}$	
Weight of electrolyte in glass jar, lbs.....	18 $\frac{3}{4}$	22	26 $\frac{1}{2}$	27 $\frac{3}{4}$	35 $\frac{3}{4}$	40 $\frac{1}{4}$	
Weight of cell complete with electrolyte in glass jar, lbs.....	57 $\frac{3}{4}$	72	88 $\frac{1}{2}$	101 $\frac{1}{2}$	124 $\frac{1}{4}$	143 $\frac{3}{4}$	

**COMPLETE (11 CELL) OUTFITS FOR TELEPHONE SERVICE**

The following outfits cover complete equipment including accessories (with the exception of glass covers) for an 11 cell telephone battery, and include the following:

- 11 Complete Elements
- 12 Glass Jars (1 extra)
- 5 Extra Wood Separators
- 1 Hydrometer
- 1 Thermometer
- Bolt Connectors
- Terminals
- Displacement Block
- Electrolyte
- Sand Trays
- 46 Type F Glass Insulators

Size of Jars	Amperes (Ultimate of Jars) 8 Hour Discharge Rate	Approx. Shipping Weight, Lbs.
<b>11 E-5 Elements (10 Ampere 8 Hour Discharge Rate)</b>		
<b>Placed in E-5, E-7, E-9, E-11, E-13 or E-15 Glass Jars</b>		
E-5	10	800
E-7	15	1000
E-9	20	1100
E-11	25	1200
E-13	30	1500
E-15	35	1600
<b>11 E-7 Elements (15 Ampere 8 Hour Discharge Rate)</b>		
<b>Placed in E-7, E-9, E-11, E-13 or E-15 Glass Jars</b>		
E-7	15	1000
E-9	20	1100
E-11	25	1300
E-13	30	1500
E-15	35	1600
<b>11 E-9 Elements (20 Ampere 8 Hour Discharge Rate)</b>		
<b>Placed in E-9, E-11, E-13 or E-15 Glass Jars</b>		
E-9	20	1100
E-11	25	1300
E-13	30	1600
E-15	35	1700
<b>11 E-11 Elements (25 Ampere 8 Hour Discharge Rate)</b>		
<b>Placed in E-11, E-13 or E-15 Glass Jars</b>		
E-11	25	1300
E-13	30	1600
E-15	35	1700
<b>11 E-13 Elements (30 Ampere 8 Hour Discharge Rate)</b>		
<b>Placed in E-13 or E-15 Glass Jars</b>		
E-13	30	1600
E-15	35	1700
<b>11 E-15 Elements (35 Ampere 8 Hour Discharge Rate)</b>		
<b>Placed in E-15 Glass Jars</b>		
E-15	35	1700

NOTE: If battery is to be in two rows specify this fact in order.

**Glass Covers**

Glass covers are not listed in the above outfits. If desired, however, they can be furnished when specified.

**METHOD OF ORDERING**

Orders for complete storage battery outfits of the above described type should read as follows:

One complete Type E storage battery outfit including accessories (except glass covers) consisting of 11 E- (give size) elements placed in E- (give size) glass jars, as described on page 24 of your telephone catalog No. 3.

Telephone Apparatus and Supplies

## STORAGE BATTERIES

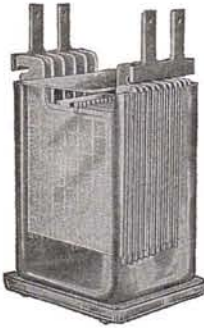

Type F-11 in Style A Glass Jar

## "Chloride Accumulator"

## Type F

The Type F comprises cells ranging in capacity from 40 to 70 ampere hours at the normal eight-hour discharge rate.

They are supplied for telephone purposes in Style A glass jars. In ordering elements, or parts thereof, specify "for use with Style A glass jars."

## INDIVIDUAL CELLS

Manufacturer's Designation.....	F-9	F-11	F-13	F-15
Discharge in amperes { For 8 hours..... For 5 hours..... For 3 hours.....	40	50	60	70
	56	70	84	98
	80	100	120	140
Normal charging rate in amperes.....	40	50	60	70
Outside dimensions of Style A glass jar, inches { Length..... Width..... Height.....	8 $\frac{1}{2}$	9 $\frac{3}{4}$	11	12 $\frac{3}{4}$
	12 $\frac{3}{4}$	12 $\frac{3}{8}$	12 $\frac{3}{4}$	12 $\frac{3}{4}$
	17	17	17	17
Height of cell in Style A glass jar from bottom of sand tray to top of strap, inches.....	23 $\frac{3}{4}$	23 $\frac{3}{4}$	23 $\frac{3}{4}$	23 $\frac{3}{4}$
Weight of electrolyte in Style A glass jar, lbs.....	53	59	66 $\frac{1}{2}$	76
Weight of cell complete with electrolyte in Style A glass jar, lbs.....	174 $\frac{3}{4}$	201 $\frac{3}{4}$	222 $\frac{1}{2}$	266 $\frac{1}{2}$

## COMPLETE (11 CELL) OUTFITS FOR TELEPHONE SERVICE

The following outfits cover complete equipment including accessories (with the exception of glass covers) for an 11 cell telephone battery, and include the following:

11 Complete Elements	Bolt Connectors
12 Glass Jars (1 extra)	Terminals
5 Extra Wood Separators	Displacement Block
1 Hydrometer	Electrolyte
1 Thermometer	Sand Trays
	46 Type F Glass Insulators

Size of Jars	Amperes (Ultimate of Jars) 8 Hour Discharge Rate	Approx. Shipping Weight, Lbs.
<b>11 F-9 Elements (40 Ampere 8 Hour Discharge Rate) Placed in F-9, F-11, F-13 or F-15 Glass Jars</b>		
F-9	40	2600
F-11	50	2979
F-13	60	3300
F-15	70	3800
<b>11 F-11 Elements (50 Ampere 8 Hour Discharge Rate) Placed in F-11, F-13 or F-15 Glass Jars</b>		
F-11	50	3000
F-13	60	3300
F-15	70	3800
<b>11 F-13 Elements (60 Ampere 8 Hour Discharge Rate) Placed in F-13 or F-15 Glass Jars</b>		
F-13	60	3300
F-15	70	3800
<b>11 F-15 Elements (70 Ampere 8 Hour Discharge Rate) Placed in F-15 Glass Jars</b>		
F-15	70	3800

NOTE: If battery is to be in two rows, specify this fact in order.

## Glass Covers

Glass covers are not included in the above outfits. If desired, however, they can be furnished when specified.

## METHOD OF ORDERING

Orders for complete storage battery outfits of the above described type should read as follows:  
One complete Type F storage battery outfit including accessories (except glass covers) consisting of 11 F- (give size) elements placed in F- (give size) glass jars, as described on page 25 of your telephone catalog No. 3.

## PORTABLE STORAGE BATTERIES

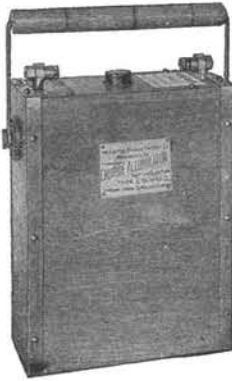

No. 501

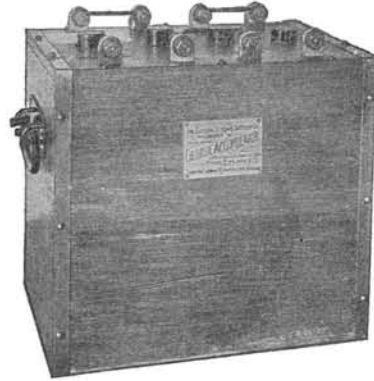

No. 504

## "Chloride Accumulator"

For portable use in connection with phonograph, kinetoscope, other small motor work and small electric lamps, the "Chloride Accumulator" is put up in sealed rubber jars enclosed in hardwood case provided with handles and suitable connection terminals. Unless otherwise ordered, portable batteries will be shipped filled with electrolyte and charged ready for service.

Each cell, when discharging, gives approximately two volts, and as all the cells in a case are connected together in series, the number of cells multiplied by two will give the approximate voltage between the outside connectors of each case.

The normal rate is the highest rate in amperes at which the battery should be charged. At this rate the battery will be fully charged in nine hours and discharged in eight hours.

## List Prices and Data

List No.	No. of Cells in Case	Type No. of Plates	Normal Ch. and Dis. Rate, Amps.	Outside Dimensions of Case, Inches			Height over Lugs Inches	Weight Lbs. Complete	*List Price Charged
				Length	Width	Height			
301	1	C 3	1 1/4	3 1/4	5 1/8	8 7/8	10 1/8	8	\$7.20
302	2	C 3	1 1/4	5 1/8	5 1/8	8 7/8	10 1/8	14	12.96
303	3	C 3	1 1/4	7	5 1/8	8 7/8	10 1/8	20	18.00
304	4	C 3	1 1/4	8 7/8	5 1/8	8 7/8	10 1/8	26	23.04
305	5	C 3	1 1/4	10 7/8	5 1/8	8 7/8	10 1/8	32	27.36
401	1	D 3	2 1/2	3 1/4	7 7/8	10 3/4	11 1/2	15	9.36
402	2	D 3	2 1/2	5 1/4	7 7/8	10 3/4	11 1/2	26	17.28
403	3	D 3	2 1/2	7	7 7/8	10 3/4	11 1/2	37	23.76
404	4	D 3	2 1/2	8 5/8	7 7/8	10 3/4	11 1/2	48	30.24
405	5	D 3	2 1/2	10 1/2	7 7/8	10 3/4	11 1/2	59	36.00
406	1	D 5	5	4 1/4	7 1/8	10 3/4	11 1/2	24	14.40
407	2	D 5	5	7	7 1/8	10 3/4	11 1/2	43	25.92
408	3	D 5	5	9 7/8	7 1/8	10 3/4	11 1/2	62	37.44
409	4	D 5	5	13	7 1/8	10 3/4	11 1/2	81	46.08
410	5	D 5	5	15 1/2	7 1/8	10 3/4	11 1/2	100	54.72
411	1	D 7	7 1/2	5 1/4	7 3/8	10 3/4	11 1/2	33	17.28
412	2	D 7	7 1/2	9 1/8	7 3/8	10 3/4	11 1/2	58	31.68
413	3	D 7	7 1/2	13	7 3/8	10 3/4	11 1/2	83	43.20
414	4	D 7	7 1/2	16 1/8	7 3/8	10 3/4	11 1/2	108	57.60
415	5	D 7	7 1/2	20 3/4	7 3/8	10 3/4	11 1/2	133	72.00
501	1	E 5	10	4 1/4	9 1/8	12 1/4	13 1/2	33 1/2	20.88
502	2	E 5	10	7 1/8	9 1/8	12 1/4	13 1/2	60	40.32
503	3	E 5	10	10	9 1/8	12 1/4	13 1/2	86 3/4	57.60
504	4	E 5	10	13 1/4	9 1/8	12 1/4	13 1/2	113 1/4	72.00
505	5	E 5	10	15 3/4	9 1/8	12 1/4	13 1/2	140	86.40
506	1	E 7	15	5 3/8	9 3/8	12 3/4	13 3/2	42 1/4	25.92
507	2	E 7	15	9 1/4	9 3/8	12 3/4	13 3/2	82 1/2	50.40
508	3	E 7	15	13 1/4	9 3/8	12 3/4	13 3/2	122 3/4	72.00
509	4	E 7	15	17 1/8	9 3/8	12 3/4	13 3/2	163	86.40
510	1	E 9	20	6 1/2	9 7/8	12 3/4	13 3/2	44 7/8	30.24
511	1	E 11	25	7 3/8	9 7/8	12 3/4	13 3/2	53 1/2	36.00

Packing charges on portable batteries to 100 lbs., 25 cents each; over 100 lbs., 50 cents each net.

\*Delivery F. O. B. Factory, Philadelphia, Pa. For warehouse deliveries write nearest house.

## PORTABLE STORAGE BATTERIES

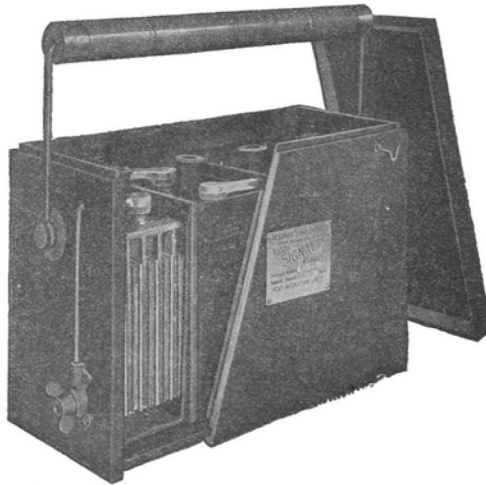

Four SS 9 Signal Cells Assembled in Case. No. 8484  
(Side of case and jar cut away to show construction)

## The "Exide" Battery

Batteries of the "Exide" type have been exclusively used in railway signal and interlocking service to replace primary cells for operating the semaphores. As each cell of storage battery replaces 8 or more primary cells for this service, and the attention required is also reduced to a minimum, their superiority is apparent.

They are also largely used for small motor work where a large capacity for a minimum weight is desirable.

Unless otherwise ordered, these batteries are shipped filled with electrolyte and charged ready for service. Each cell, when discharged, gives approximately two volts, and as all the cells in a case are connected together in series, the number of cells multiplied by two will give the approximate voltage between the outside terminals of each case.

## List Prices and Data

List No.	No. of Cells in Case	Type and No. of Plates	Ampere Hour Capacity at Service Rate	Charging Rate in Amperes	Outside Dimensions of Case, in Inches			Weight Complete, in Pounds	†Price Complete, Charged
					*Length	Width	Height		
8462.....	2	SS 5	40	4	5 $\frac{3}{8}$	6 $\frac{1}{8}$	11 $\frac{1}{4}$	21	\$20.16
8463.....	3	SS 5	40	4	7 $\frac{1}{8}$	6 $\frac{1}{8}$	11 $\frac{1}{4}$	30	29.16
8464.....	4	SS 5	40	4	9 $\frac{1}{2}$	6 $\frac{1}{8}$	11 $\frac{1}{4}$	39 $\frac{1}{4}$	38.16
8465.....	5	SS 5	40	4	11 $\frac{1}{8}$	6 $\frac{1}{8}$	11 $\frac{1}{4}$	48 $\frac{1}{2}$	47.16
8466.....	6	SS 5	40	4	13 $\frac{3}{8}$	6 $\frac{1}{8}$	11 $\frac{1}{4}$	57	56.16
8472.....	2	SS 7	60	6	6 $\frac{7}{8}$	6 $\frac{1}{8}$	11 $\frac{1}{4}$	22 $\frac{3}{4}$	24.84
8473.....	3	SS 7	60	6	9 $\frac{1}{2}$	6 $\frac{1}{8}$	11 $\frac{1}{4}$	34 $\frac{1}{4}$	36.36
8474.....	4	SS 7	60	6	12 $\frac{1}{2}$	6 $\frac{1}{8}$	11 $\frac{1}{4}$	45 $\frac{1}{2}$	47.88
8475.....	5	SS 7	60	6	15 $\frac{1}{8}$	6 $\frac{1}{8}$	11 $\frac{1}{4}$	56 $\frac{1}{2}$	59.40
8476.....	6	SS 7	60	6	19 $\frac{1}{2}$	6 $\frac{1}{8}$	11 $\frac{1}{4}$	67	70.92
8482.....	2	SS 9	80	8	8 $\frac{1}{4}$	6 $\frac{1}{8}$	11 $\frac{1}{4}$	35 $\frac{1}{4}$	29.88
8483.....	3	SS 9	80	8	11 $\frac{1}{8}$	6 $\frac{1}{8}$	11 $\frac{1}{4}$	44	43.20
8484.....	4	SS 9	80	8	15 $\frac{1}{8}$	6 $\frac{1}{8}$	11 $\frac{1}{4}$	58 $\frac{3}{4}$	56.52
8485.....	5	SS 9	80	8	19 $\frac{1}{4}$	6 $\frac{1}{8}$	11 $\frac{1}{4}$	72 $\frac{1}{2}$	69.84
8486.....	6	SS 9	80	8	22 $\frac{3}{4}$	6 $\frac{1}{8}$	11 $\frac{1}{4}$	86	83.16
8492.....	2	SS11	100	10	10 $\frac{1}{4}$	6 $\frac{1}{8}$	11 $\frac{1}{4}$	42 $\frac{3}{4}$	35.64
8493.....	3	SS11	100	10	14 $\frac{3}{4}$	6 $\frac{1}{8}$	11 $\frac{1}{4}$	63	51.48
8494.....	4	SS11	100	10	19 $\frac{1}{2}$	6 $\frac{1}{8}$	11 $\frac{1}{4}$	83 $\frac{1}{4}$	67.32
8495.....	5	SS11	100	10	24 $\frac{1}{4}$	6 $\frac{1}{8}$	11 $\frac{1}{4}$	103 $\frac{3}{4}$	83.16
8496.....	6	SS11	100	10	28 $\frac{3}{4}$	6 $\frac{1}{8}$	11 $\frac{1}{4}$	123	99.00

\*For length over handles and terminals, add 3 inches.

Packing charges on portable batteries to 100 lbs., 25 cents each; over 100 lbs., 50 cents each net.

†Delivery F. O. B. Factory, Philadelphia, Pa. For warehouse deliveries write nearest house.

**LIQUID BATTERY UTENSILS**

**Thermometers**

**Pocket Style**



No. 141



No. 101



No. 102

List No.		*List Price Each
141	Pocket, Nickel case, 5½ inches long, 20° to 120° F.	\$1.50
<b>Standard Chemical</b>		
142	Chemical, 10 inches long, 20° to 220° F.	\$2.26
<b>Floating Style</b>		
143	Floating thermometer	\$0.76

**Storage Battery Hydrometers**

Or for liquids heavier than water



No. 142



No. 103



No. 106



No. 107



Nos. 109 and 110

List No.		List Price Each
101	Standard Storage Battery Hydrometer, shot bulb, 5 inches long, double scale, 10 to 40 Baume, 1,050 to 1,400 Sp. G., with glass jar in polished box.	\$1.14
<b>Hydrometer with Guiding Points</b>		
102	Hydrometer with guiding points, shot bulb, with red line at 25B, 5 inches long, double scale, 10 to 40 B, 1,050 to 1,400 Sp. G.	\$1.50
<b>Flat Bulb Hydrometer</b>		
103	Small, flat bulb, used in car lighting batteries, shot bulb, 4½ inches long, single scale, 1,100 to 1,250 Sp. G.	\$1.14
<b>Large Standard Hydrometer</b>		
106	Large standard (not illustrated), very accurate, shot bulb, 12 inches long, double scale, 0 to 70 B, 1,000 to 2,000 Sp. G.	\$1.50
<b>Combined Hydrometer and Thermometer</b>		
107	Large Standard, combined with thermometer, 0 to 140 F, 12 inches long, double scale, 0 to 70 B, 1,000 to 2,000 Sp. G. hydrometer.	\$4.50
<b>Large Flat Bulb Hydrometer</b>		
108	Large, flat bulb (not illustrated), used in large stationary cells, shot bulb, 10 inches long, ⅜ inch thick, single scale, 1,050 to 1,250 Sp. G.	\$2.26
<b>For Gravity Battery</b>		
109	Small Hydrometer for gravity batteries, 4½ inches long; Baume and Specific Gravity scale, 15° to 35° B, 1,100 to 1,300 Sp. G.—4½ inches long with glass jar and wood box.	\$0.76
110	Same as No. 109, but in aluminum box.	\$1.14

\*Delivery F. O. B. New York City.  
Telephone Apparatus and Supplies

For warehouse deliveries write nearest house.

LIQUID BATTERY UTILS



Electrolyte Tester

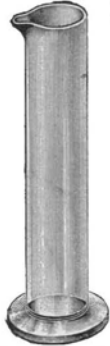

Hydrometer Jar



Acid Syringe



Hard Rubber Battery Syringe



Bulb Syringe

The Electrolyte Tester

List No.

181 This instrument takes the place of the usual Hydrometer, Hydrometer Jar and Syringe and combines in one simple device a means for testing the electrolyte or acid of a storage battery. It is self contained, length 6 inches. The instrument is put up in a polished wood box with directions for use. Weight, 5 ounces.

\*List Price Each

\$2.26

List No.

Hydrometer Jars

- 104 6 x 1 in. Hydrometer Jars for Hydrometers 101-102. . . . . \$0.46
- 131 12 x 2 in. Hydrometer Jars for Hydrometers 106-107. . . . . 1.36

Acid Syringe, One Piece

- 190 Pure gum, 1 oz., 1 1/2 in. diameter, 3 1/2 in. long. . . . . \$0.38
- 191 Pure gum, 3 oz., 2 1/2 in. diameter, 5 in. long. . . . . .90
- 192 Pure gum, 6 oz., 3 in. diameter, 6 in. long. . . . . 1.50

Hard Rubber Battery Syringe

- 136 Hard rubber, capacity 12 oz. . . . . \$6.00
- 137 Extra nozzle, 6 ins. long. . . . . .90
- 138 Hard rubber, capacity 32 oz. . . . . 18.00
- 139 Extra nozzle, 9 ins. long. . . . . 1.50
- 140 Extra nozzle, 24 ins. long. . . . . 3.38

Bulb Syringe

For filling and equalizing the acid in batteries. Heavy, quick-acting rubber bulb, capacity 8 ounces, furnished with a straight and bent nozzle. Complete, in wooden box.

- List No. \*List Price Each
- 105 Bulb Syringe, complete, in wooden box. . . . . \$2.26
  - 132 Extra bulb, with fitting. . . . . 1.50
  - 133 Extra nozzles. . . . . .54

\*Delivery F. O. B. New York City. For warehouse deliveries write nearest house.

Hydrometer Syringes

For testing the specific gravity of any liquid without first pouring it into a separate vessel such as a hydrometer jar.

Consists of a glass tube with rubber suction bulb at the top, a hard rubber nozzle at the bottom, and containing a specially designed hydrometer which is free to rise and fall and indicates the specific gravity of the liquid drawn up into the tube.

Style

- A Hydrometer float graduated in both Baume 10° to 40° and specific gravity 1050 to 1400, with buffer on each end to prevent breaking. Complete with one plain nozzle, one special nozzle for filling storage cells with electrolyte to proper level above plates, and one drip cup, all contained in a polished oak box. . . . . \$9.00\*
- B Without guiding points on hydrometer, or special nozzle. Graduated 1150 to 1325 specific gravity only. Packed in a plain box. . . . . 4.50\*
- C Has smaller bulb and hydrometer than Style B. Hydrometer graduated Baume 15° to 35° and specific gravity 1100 to 1300. Packed in a plain box. . . . . 2.26\*

\*F. O. B. New York City.

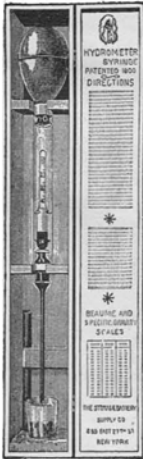

Style A

BATTERY GAUGES



No. 35 Battery Gauge

Western Electric No. 35

Description  
 Designed expressly for testing dry batteries used in connection with Western Electric or other high resistance telephone transmitters.

Single cells or three in series can be tested. When two cells are used a test can be made by testing each cell separately.

The "cut-off point" is the point at which it has been determined a dry cell should be removed from service, where it is desired to secure maximum transmission results.

This gauge can also be used for testing dry cells used in interrupter or pole changer, and coil-collector service. . . . . \$9.90

Ever Ready Pocket Meter



These meters have the smallest possible number of working parts and are therefore least liable to get out of order. The hand comes to an instant and positive stop without vibration, giving a quick reading and saving the battery. Will work in either direction of current. Each instrument furnished in a chamois leather case.

List No.	Type	Range	Diameter	List Price Each
1002	Ammeter	0 to 35 amps.	2 ins.	\$1.30
1003	Volt-ammeter	0 to 35 amps.-0 to 11 volts	2 ins.	1.60
1005	Voltmeter	0 to 10 volts	2 ins.	1.40
1007	Coil tester	0 to 3 amps.	2 ins.	2.00
1008	Coil tester and ammeter	{ 0 to 30 amps. 0 to 3 amps.	2 ins.	2.20
1010	Ammeter	0 to 35 amps.	1 1/4 ins.	1.30
1011	Volt-ammeter	0 to 35 amps.-0 to 11 volts	1 1/4 ins.	1.60
1012	Voltmeter	0 to 10 volts	1 1/4 ins.	1.40

Telephone Apparatus and Supplies

## BATTERY CABINETS

### Interrupter Battery Cabinet

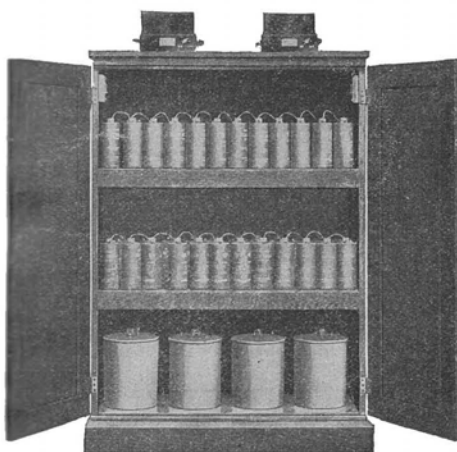

No. 1441B Battery Cabinet

Oak cabinets for accommodating dry batteries and Edison primary batteries necessary to operate our No. 84 interrupter. The interrupters can be mounted on the top or vertically on the back. The dry or gravity batteries used in the transmitter circuit of magnetic switchboards can also be included if desired.

Three sizes of these cabinets are furnished as follows:

Code No.	Accommodations for			List Price Each
	No. 84 Interrupter	Dry Cells	Edison BSCO Cells	
1440B	1	72	2	\$45.30
1441B	2	140	4	89.70
1442	2	280	4	102.00

### Storage Battery Cabinets

Destructive and irritating fumes escape from a storage battery during periods of charging. These fumes attack the charging apparatus as well as any inclosing structure unless it is carefully designed to overcome this acid action.

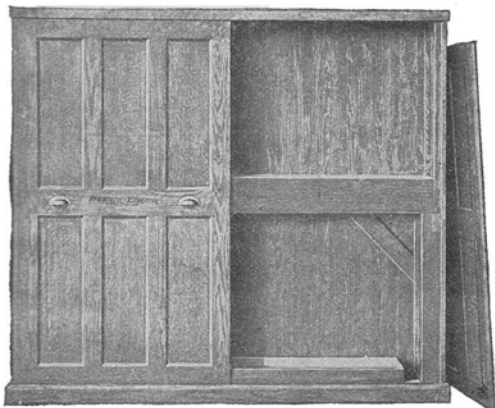

No. 1554 Storage Battery Cabinet

Western Electric storage battery cabinets are constructed of oak, having doors and sides of mortised panel construction. The doors can be easily removed exposing the entire interior of the cabinet and permitting of access to all parts for inspection and maintenance.

The interior is heavily coated with an acid resisting paint, which prevents the wood from being rotted by the acid fumes.

Wooden sand trays mounted on glass insulators are furnished.

These cabinets are of two types, one having a removable front and hinged top and designated as "chest" type cabinet, and the other as "cabinet" type, having removable doors only. These two types of cabinets can be easily identified by the dimensions, the "chest" type being 1 foot 9¼ inches high, while the "cabinet" type varies from 5 to 7 ft. 5 inches in height.

Code No.	Type	Dimensions			No. of Cells	Type of Cell	List Price Each
		Height	Width	Length			
1450	"Chest"	1 ft. 9¼ ins.	11 ins.	3 ft. 0 ins.	11	BT., CT. or PT.	\$30.90
1451		1 ft. 9¼ ins.	1 ft. 1½ ins.	3 ft. 0 ins.	11	ET.	49.40
1452		1 ft. 9¼ ins.	1 ft. 6¼ ins.	3 ft. 0 ins.	22	BT., CT. or PT.	41.69
1453		1 ft. 9¼ ins.	1 ft. 11¼ ins.	3 ft. 0 ins.	22	ET.	55.40
1454	"Cabinet"	5 ft. 0 ins.	1 ft. 2 ins.	5 ft. 4 ins.	11	D-11	141.90
1455		5 ft. 5¾ ins.	1 ft. 2 ins.	5 ft. 11 ins.	11	E-11	146.10
1456	"Chest"	1 ft. 9¼ ins.	1 ft. 6¼ ins.	5 ft. 6 ins.	40	BT., CT. or PT.	96.90
1457		1 ft. 9¼ ins.	1 ft. 11¼ ins.	5 ft. 6 ins.	40	ET.	133.60
1458	"Cabinet"	5 ft. 0 ins.	1 ft. 6¼ ins.	9 ft. 4⅝ ins.	22	D-9	238.80
1459		7 ft. 5 ins.	1 ft. 6¼ ins.	11 ft. 9⅝ ins.	40	D-9	318.80
1460		5 ft. 4 ins.	1 ft. 8⅞ ins.	10 ft. 11½ ins.	22	E-7, E-9 or E-11	237.50

## PATTERSON BATTERY SETS

### General

#### SCREW TOP CELLS

A screw top dry cell is used with these sets. The cells being screwed into receptacles, thereby automatically making all connections without the use of jumper wires or binding posts.

Loose connections and resulting loss of power are impossible. It is as easy to replace any cell as it is to replace a burned-out incandescent lamp. Simply screw the cell into the receptacle.

When the circuit or line wires have been once connected to the battery-set terminals, (they never have to be disconnected or reconnected), although any predetermined change of circuit connections may, of course, be made to take care of any specific conditions.



Screw Top Cell

#### AUTOMATIC BRIDGE

In all series type battery sets later described, each cell receptacle is equipped with a spring bridge contact which automatically short-circuits the receptacle as soon as the cell is removed. This permits the removal of any cell or cells from the battery set without opening the circuit and temporarily putting the system out of commission; this also provides a quick test for a weak cell without the use of an ammeter or other testing apparatus.

Individual cells may be tested with an ammeter or battery gauge without removing the cell from its holder, or a test of the complete bank of cells may be made at the cabinet terminals.

### General Types

Various types of Patterson Battery Cabinets for telephone service are listed on the following pages, differing primarily in the method of mounting. Each type is arranged for different circuit combinations to suit the requirements of the particular system for which it is intended.

In some instances only one battery is required with its cells connected in series. In other cases two separate batteries are necessary, the cells of each connected in series, but the carbon side of both batteries strapped together. This arrangement is called a "split circuit."

All the cabinets listed are arranged for series connection of the cells, regardless of whether one or two batteries are used. For ordinary conditions this arrangement is satisfactory. However, where the service is severe, it is recommended that cabinets provided for multiple-series connections be used, that is, two separate batteries are used instead of one with the cells connected in series, but the batteries connected in multiple.

Information and prices on these multiple series cabinets will be furnished on request.



Model "B"  
Strip Type



Model "BR"  
Side-wall Type

#### STRIP TYPE

**Model B:** This is the simplest type, and is designed for use where the battery holder can be mounted on the ceiling, under-side of a shelf, or other similar location where the support is solid and permits of easy access all around to screw in or remove the battery cells. They are furnished with galvanized hinge-brackets for mounting on a side-wall, but for this purpose the side-wall type Model BR is recommended and is preferable.

#### SIDE-WALL TYPE

**Model BR:** This type is designed for mounting on the wall or other vertical surface, and consists of a metal-faced backboard on which is hinged a strip type holder equipped with knife switch blades which, when the holders are dropped into place, make contact with jaws rigidly mounted on the backboard. Stationary binding posts or terminals are also mounted on the backboard.

## PATTERSON BATTERY SETS

### General Types (Continued)



Model BB—Open



Model BSC—Flush Type



Model BB—Closed

#### NON-FLUSH STEEL BOX TYPE

**Model BB:** This type consists of a strip type holder mounted in a pressed steel box, finished in black japan; the top and back are hinged to permit of ready inspection. The binding posts are permanently located on the backboard of the box, and the holders mounted on the top and equipped with knife switch blades which, when the box is closed, make contact with jaws mounted on the backboard in exactly the same manner as the side-wall type.

#### WALL CABINET TYPE

**Model BSC:** This type is essentially a steel box equipped with side-wall type holders and having regular cabinet casings, either for flush or non-flush mounting, as desired, and with the door equipped with a cylinder lock instead of a padlock.

### For Inter-phone Systems No. 1

This system requires 2 separate batteries consisting of 5 cells for talking and 4 to 7 cells for ringing, having the carbon side of both the talking and ringing batteries strapped together.

The following special "split circuit" battery sets, having the carbon terminals of both batteries connected together as part of the permanent wiring of the set, are recommended for the above systems.

#### STRIP TYPE MODEL B

##### Series Split Circuit

Model No.	No. Cells		List Price Each No Batteries
	Talking	Ringing	
BW-5-4	5	4	\$13.50
BW-5-5	5	5	15.00
BW-5-7	5	7	18.00

#### SIDE-WALL TYPE—MODEL BR

##### Series Split Circuit

Model No.	No. Cells		List Price Each No Batteries
	Talking	Ringing	
BRW-5-4	5	4	\$17.40
BRW-5-5	5	5	18.88
BRW-5-7	5	7	22.32

#### NON-FLUSH STEEL BOX TYPE—MODEL BB

##### Series Split Circuit

Model No.	No. Cells		List Price Each No Batteries
	Talking	Ringing	
BBW-5-4	5	4	\$21.80
BBW-5-5	5	5	23.65
BBW-5-7	5	7	27.95

#### WALL-CABINET TYPE—MODEL BSC

##### Series Split Circuit

Model No.	No. Cells Talking	No. Cells Ringing	List Price Each, No Batteries			
			Non-flush Oak	Flush Oak	Non-flush Steel	Flush Steel
BSCW-5-4	5	4	\$48.30	\$58.26	\$33.60	\$40.02
BSCW-5-5	5	5	54.60	65.82	38.10	43.02
BSCW-5-7	5	7	62.40	75.18	44.10	53.22

## PATTERSON BATTERY SETS

### For Inter-phone Systems No. 7, 8, 9 and 10

These systems usually require in addition to a "split circuit" battery consisting of five cells for "talking" and 3 to 6 for "ringing," having the carbon side of both the "talking" and "ringing" sets connected or strapped together, an extra "split" of a number of cells for the door opener having the carbon side strapped to the zinc side of the "ringing" battery.

Battery sets arranged with this special strapping for the above systems are listed below.

#### STRIP TYPE—MODEL "B"

##### Series Split Circuit

Model No.	No. Cells Talking	No. Cells Ringing	No. Cells Door Opener	List Price Each No Batteries
BW-5-3-2	5	3	5	\$15.00
BW-5-4-2	5	4	6	16.50
BW-5-5-2	5	5	7	18.00
BW-5-6-2	5	6	8	19.50

#### SIDE WALL TYPE—MODEL "BR"

##### Series Split Circuit

Model No.	No. Cells Talking	No. Cells Ringing	No. Cells Door Opener	List Price Each No Batteries
BRW-5-3-2	5	3	5	\$20.60
BRW-5-4-2	5	4	6	22.32
BRW-5-5-2	5	5	7	24.05
BRW-5-6-2	5	6	8	25.76

#### NON FLUSH STEEL BOX TYPE—MODEL "BB"

##### Series Split Circuit

Model No.	No. Cells Talking	No. Cells Ringing	No. Cells Door Opener	List Price Each No Batteries
BBW-5-3-2	5	3	5	\$25.80
BBW-5-4-2	5	4	6	27.95
BBW-5-5-2	5	5	7	30.10
BBW-5-6-2	5	6	8	32.25

#### WALL CABINET TYPE—MODEL "BSC"

##### Series Split Circuit

Model No.	No. Cells Talking	No. Cells Ringing	No. Cells Door Opener	List Price Each, No Batteries			
				Flush Steel	Non Flush Steel	Flush Oak	Non Flush Oak
BSCW-5-3-2	5	3	5	\$43.92	\$36.60	\$63.72	\$53.10
BSCW-5-4-2	5	4	6	47.58	39.65	69.03	57.53
BSCW-5-5-2	5	5	7	51.24	42.70	74.34	61.96
BSCW-5-6-2	5	6	8	54.90	45.75	79.65	66.39

### For Inter-phone System No. 14

This system requires a "split circuit" battery set having two cells only for the talking circuit, and one, two or three additional cells for the ringing circuit, depending on the length of line.

#### STRIP TYPE—MODEL "B"

##### Series Split Circuit

Model No.	No. Cells Talking	No. Cells Ringing	List Price Each No Batteries
B-2-1	2	1	\$4.50
B-2-2	2	2	6.00
B-2-3	2	3	7.50

#### SIDE WALL TYPE—MODEL "BR"

##### Series Split Circuit

Model No.	No. Cells Talking	No. Cells Ringing	List Price Each No Batteries
BR-2-1	2	1	\$7.70
BR-2-2	2	2	9.40
BR-2-3	2	3	11.00

#### NON-FLUSH STEEL BOX TYPE—MODEL "BB"

##### Series Split Circuit

Model No.	No. Cells Talking	No. Cells Ringing	List Price Each No Batteries
BB-2-1	2	1	\$9.60
BB-2-2	2	2	11.70
BB-2-3	2	3	13.80

#### WALL CABINET TYPE—MODEL "BSC"

##### Series Split Circuit

Model No.	No. Cells Talking	No. Cells Ringing	List Price, No Batteries			
			Flush Steel	Non Flush Steel	Flush Oak	Non Flush Oak
BSC-2-1	2	1	\$17.76	\$14.80	\$30.96	\$25.80
BSC-2-2	2	2	20.76	17.30	35.16	29.30
BSC-2-3	2	3	23.88	19.90	39.60	33.00

Telephone Apparatus and Supplies

## PATTERSON BATTERY SETS

### For Inter-phone Systems Nos. 11, 12, 15 and 16

A straight series battery is required to consist of from 3 to 6 cells, depending on the system and the length of line. The following sets, when ordered with the proper capacity, can be used in any of these systems.

STRIP TYPE—MODEL "B"			SIDE WALL TYPE—MODEL "BR"		
Series Connection			Series Connection		
Model No.	No. Cells	List Price Each No Batteries	Model No.	No. Cells	List Price Each No Batteries
B-3	3	\$4.50	BR-3	3	\$6.10
B-4	4	6.00	BR-4	4	7.70
B-5	5	7.50	BR-5	5	9.40
B-6	6	9.00	BR-6	6	11.00

### NON-FLUSH STEEL BOX TYPE—MODEL "BB"

Series Connection

Model No.	No. Cells	List Price Each No Batteries
BB-3	3	\$7.80
BB-4	4	9.60
BB-5	5	11.70
BB-6	6	13.80

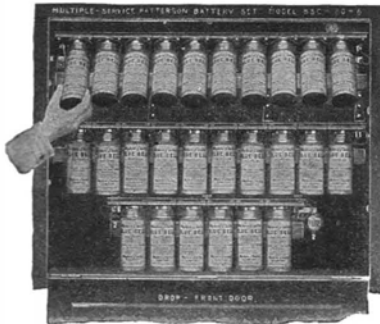

BSC-6+20

### WALL CABINET TYPE—MODEL "BSC"

Series Connection

Model No.	No. Cells	List Price, No Batteries			
		Flush Steel	Non Flush Steel	Flush Oak	Non Flush Oak
BSC-3	3	\$14.88	\$12.40	\$27.00	\$22.50
BSC-4	4	17.76	14.80	30.96	25.80
BSC-5	5	20.76	17.30	35.16	29.30
BSC-6	6	23.88	19.90	39.60	33.00

## For No. 1801 Switchboards

### SYSTEMS A, B, C AND D

—The new No. 1801 switchboard requires two separate batteries for its operation—

**One Battery**  
Consisting of six dry cells connected in series for

**Talking**  
System A  
System B  
\*System C  
\*System D

\*If the outgoing trunks are to a magneto exchange, two dry cells should be added to the talking battery.

For light service installations series outfits will be satisfactory. For heavy service installations multiple outfits are preferable.

**One Battery**  
Consisting of twenty dry cells connected in series for

**Line Lamps and Ringing**  
System A  
System B  
System C  
System D  
‡

‡A hand generator or interrupter is used for ringing in System D.

Model No.	Type	Total Cell Capacity	List Price, No Batteries			
			Non Flush Oak Case	Flush Oak Case	Non Flush Steel Case	Flush Steel Case
BSC- 6+ 20	Series	26	\$88.11	\$107.05	\$82.50	\$100.32
BSC- 8+ 20	Series	28	91.41	110.35	85.80	103.62
BMC-26+220	Multiple	52	155.76	189.55	162.23	197.32
BMC-28+220	Multiple	56	162.36	196.15	168.83	203.92

**NOTE:** The series type set contains two separate batteries, one consisting of either six or eight cells, the other one of twenty cells. The multiple type set contains two batteries of either six or eight cells each and two batteries of twenty cells each.



No. 1-A—Battery Box

**BATTERY BOXES**

Black finish pressed metal box lined with insulating material. Removable cover.

**FOR HOLDING STANDARD NO. 6 DRY CELLS**

Code No.	Capacity Dry Cells	Dimensions Inches	List Price Each
1A	3	3 1/4 x 7 1/8 x 9 7/16	\$1.30
2B	9	5 3/2 x 7 1/8 x 14 3/8	5.00

**BELLS AND BUZZERS**

**For Direct Current**

**BELLS—No. 10 TYPE**

Iron box vibrating bells having platinum contacts and 3 inch gongs used in switchboards for night alarm service.

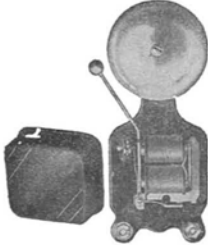

No. 10 Type Bell

Code No.	Resistance Ohms	Rated Voltage	List Price Each
10A	2.5	3	\$1.60
10B	15.	7	2.30
10C	110.	15	2.40
10D	335.	24	2.50
10E	800.	36 and 48	2.80

**BUZZERS—No. 10 TYPE**

Similar to above bells with exception of gongs.

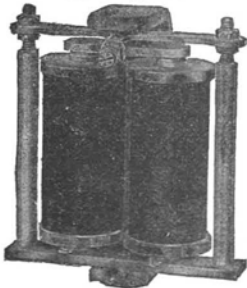

No. 1-A—Buzzer

Code No.	Resistance Ohms	Rated Voltage	List Price Each
10A	2.5	3	\$1.50
10B	15.	7	2.20
10C	110.	15	2.30
10D	335.	24	2.40
10E	800.	36 and 48	2.70



No. 10 Type Buzzer

**BELLS—No. 11 TYPE**

Iron box vibrating bells having silver contacts and 3 inch gongs.

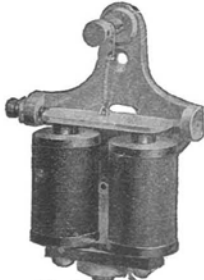

No. 2-D—Buzzer

Code No.	Resistance Ohms	Rated Voltage	Use	List Price Each
11B	15	7	Interphone service	\$1.50
11D	335	24	No. 6034 type telephone in 1801 switchboard system	3.10

**Bells for Alternating Current**

(See Extension Bells)

**Buzzers for Alternating Current**

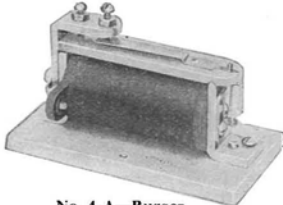

No. 4-A—Buzzer

Code No.	Resistance Ohms	Used With	List Price Each
1A	1000	Telephones	\$2.30
1B	2500	Telephones	3.30
2A	100	No. 1006 type test sets	1.10
2C	1000		1.50
2D	100	No. 1017 type test sets	1.10
3B	2500	No. 1331 type portable telephones	2.50
4A	1200	P. B. X. switchboards for 24 volts D.C. or A.C. 16 cycle ringing current	3.20

Telephone Apparatus and Supplies

## BINDING POSTS

### Self-mounting Screw Type

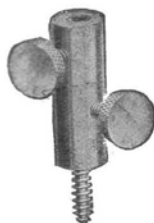

No. 1A



No. 1B

Code No.	Description	List Price	
		Finish	Each
1A	Thumb screw connections, no soldering terminals.....	Brass	\$0.36
1B	Screw connections, one front soldering terminal.....	Tin dipped	.18

### Screw Mounting Type



No. 2A

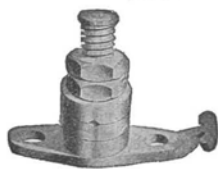

No. 2E

2A	Lock nut connections, one back soldering terminal.....	Nickel	\$0.20
2E	Lock nut connections, one front soldering terminal.....	Brass	.22
3A	Lock nut connections, one back soldering terminal.....	Nickel	.20
20A	Screw connections, one front soldering terminal.....	Nickel	.25
P-368S7	Screw connection, one soldering terminal.....	Tinned	.06

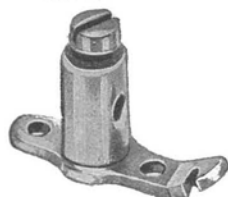

No. 20A



No. 3A

### No. 29A Type



No. 29A



No. P36887

29A	Used in No. 8 and No. 10 cable terminals when the original binding posts break off above the lower nut.....	Tinned	\$0.045
-----	---	--------	---------

### Miscellaneous Binding Posts



No. 4834



No. 4823



No. 4822



No. 4820



No. 4821



No. 4835



No. 4830



No. 4826



No. 4832



No. 4833



No. 4829



No. 4825



No. 4827



No. 4828



No. 4819



No. 4831



No. 4824

These binding posts are made of brass and can be furnished in plain brass or nickel plate at same price.

List No.	Finish	*List Price Each	List No.	Finish	*List Price Each	List No.	Finish	*List Price Each
4834	Nickel plated.....	\$0.20	4830	Nickel plated.....	\$0.12	4827	Nickel plated....	\$0.08
4823	Nickel plated.....	.18	4826	Nickel plated.....	.08	4828	Nickel plated....	.08
4822	Nickel plated.....	.12	4832	Nickel plated.....	.06	4819	Nickel plated....	.12
4820	Nickel plated.....	.16	4833	Nickel plated.....	.06	4831	Nickel plated....	.24
4821	Nickel plated.....	.14	4829	Nickel plated.....	.07	4824	Nickel plated....	.12
4835	English pattern, nickel plated....	.20	4825	Nickel plated.....	.10			

\*Special prices for quantities of 1000 or more.

TELEPHONE BOOTHS



Folding Door Telephone Booths

The telephone booths shown are our standard types furnished in oak. We carry these in stock and are prepared to ship them promptly; also booths made of other woods than oak and booths of special finish and size. These special booths, however, are considerably more expensive than the standard booths which we carry in stock.

The booths are constructed from carefully selected, thoroughly seasoned, kiln-dried timber, and are perfect in design, material and workmanship.

The booths are shipped "knock down" and can be readily set up.

A shelf is furnished as standard equipment for each booth.

The standard booths have the door hinged on the right-hand side facing the booth.

These booths are compact enough to be used in narrow passageways—they are equipped with glass panels and door and are a serviceable telephone booth for business offices, banks, factories, stores, clubs, hotels and restaurants.

The folding door features are that the door operates both ways by pulling the handle, it remains in any position, and stays closed without use of catches. There are no tracks in the floor to gather dirt and become clogged. The ventilation is perfect. The door when operated extends only four inches beyond the face of booth.

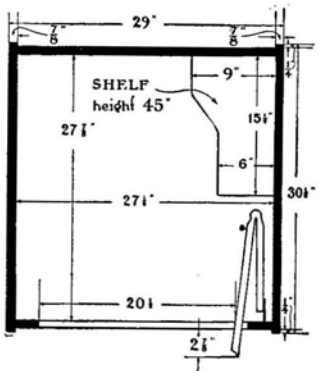

Dimensions  
Telephone Apparatus and Supplies

**Construction:** Outside finished on front, sides and back.

List No.	List Price Each
2 Folding door telephone booth.....	\$120.00

Delivery F. O. B. Factory, Brooklyn, N. Y., or Milwaukee, Wis.  
For warehouse deliveries write nearest house.

TELEPHONE BOOTHS

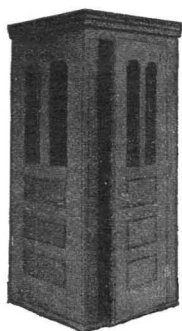

No. 13

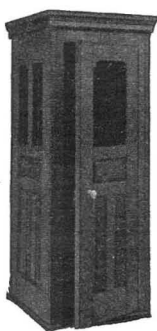

No. 30

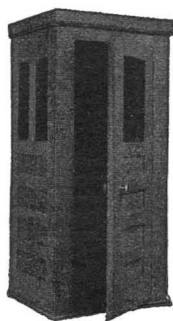

No. 40

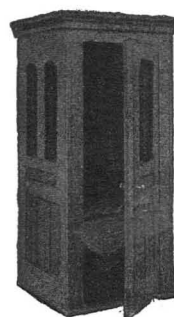

No. 48

Sound Proof Telephone Booths (Cadwell)

List No.	Material	Size		*List Price Each
		Outside	Inside	
13	Oak	38 x 38 ins.	30 x 30 ins.	\$132.00
30	Oak	35 x 32 ins.	27 x 24 ins.	123.00
40	Oak	32 x 37 ins.	26 x 31 ins.	117.00
48	Oak	38 x 38 ins.	30 x 30 ins.	126.00

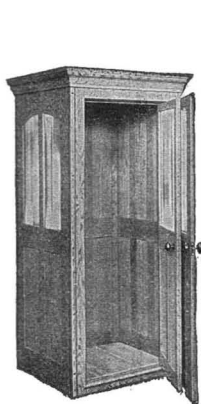

No. 20

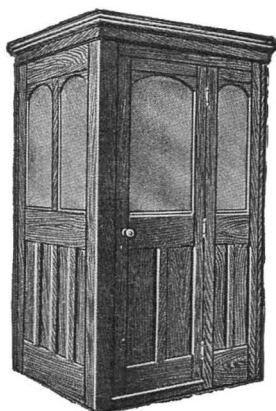

No. 21

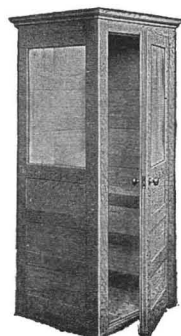

No. 25



No. 20A

Sound Proof Telephone Booths (Seaman)

List No.	Size		Glass in door and one side	†List Price Each
	Outside	Inside		
20	32 x 39 ins.	32 x 26 ins.	Glass in door only	\$111.00
20	32 x 39 ins.	32 x 26 ins.	Glass in door and one side	120.00
21	44 x 39 ins.	37 x 32 ins.	Glass in door only	129.00
21	44 x 39 ins.	37 x 32 ins.	Glass in door and one side	138.80
25	31 x 37 ins.	26 x 32 ins.	Glass in door only	84.00
25	31 x 37 ins.	26 x 32 ins.	Glass in door and one side	90.00
20A	32 x 39 ins.	26 x 32 ins.	Glass in door only	111.00
20A	32 x 39 ins.	26 x 32 ins.	Glass in door and one side	120.00

\*Delivery: F. O. B. Factory, Jamestown N. Y. For warehouse deliveries write nearest house.

†Delivery: F. O. B. Factory, Milwaukee, Wis. For warehouse deliveries write nearest house.

## LEAD COVERED TELEPHONE CABLE



Cable for aerial and underground telephone use is composed of copper conductors, insulated with either one or two wrappings of paper, twisted into pairs and enclosed in a lead sheath. In general, cable with single wrapped conductors is recommended, since its electrical and mechanical characteristics are perfectly satisfactory for most conditions, and the cost is less than of cable with double wrapped conductors. Cable intended for interior construction usually has the conductors insulated with two servings of silk and one of cotton.

The insulated conductors may be enclosed in a sheath composed of commercially pure lead, an alloy of lead and tin, or an alloy of lead and antimony. Lead antimony sheath is recommended for aerial and underground construction. Lead-tin sheath can also be furnished if desired. Pure lead sheath is recommended for use only within buildings or in similar unexposed places. It is furnished, however, on cable intended for aerial or underground use where a cheap cable is desired.

### Extra Pairs

Extra pairs are placed in all cables containing conductors smaller than No. 16 gauge, to take care of any pairs which may become defective in manufacture. In the majority of cables, all or part of the extra pairs are good and may be used for additional circuits. All pairs of No. 16 gauge and larger, except in submarine cable, are guaranteed to meet the specification requirements when the cable leaves our factory.

### Transmission

The transmitting efficiency of telephone cable, considered as a separate unit, depends principally upon its electrostatic capacity and conductor resistance. When telephone cable forms a portion of a completed telephone connection, the transmitting efficiency of the cable portion is modified by its relative position in that circuit, and also by the type of the other construction to which it is connected.

The following data is based upon average standard conditions and may be used for approximate calculations. In the case of circuits involving several different types of construction and considerable investigation, we recommend consulting our engineers.

As a measure of transmission efficiency, standard No. 19 B.&S. gauge cable, having a loop resistance of 88 ohms and a mutual electrostatic capacity of .054 M.F. per mile is used as a basis.

Thirty miles of this cable is considered the maximum distance over which commercial transmission can be secured. One mile of this cable is approximately equivalent to the following:

- 3.3 miles of No. 12 B.W.G.-B.B. galvanized iron circuit.
- 4.1 miles of No. 10 B.W.G.-B.B. galvanized iron circuit.
- 8.0 miles of No. 14 N.B.S. and 12 B.&S. or drawn bare copper circuit.
- 12.7 miles of No. 12 N.B.S. or drawn bare copper circuit.

It then follows that 99 miles is the theoretical commercial limit for No. 12 B.W.G.-B.B. galvanized iron wire circuit.

Under each listing is given the respective transmission equivalent in terms of standard No. 19 gauge cable.

#### Example

Type TA cable has approximately two-thirds of the transmitting quality of the standard cable, i.e., transmission through one mile of type TA cable will be equivalent to that through 1.53 miles of standard cable. Type TJ cable has approximately twice the transmitting quality of standard cable, three times that of TA cable.

### Electrostatic Capacity

This is a measure of that property possessed by a cable to store a greater or less charge of electricity and is a very important factor, because it determines to a large extent the length of cable through which it is possible to transmit speech. For subscribers' cables not more than two miles in length, it is generally considered economical to use fairly high capacity cable, since the decrease in transmission, due to the capacity, will be only a small percentage of the total loss in the circuit. For long lengths of cable or for those carrying important toll lines, lower capacity is usually specified.

The electrostatic capacity may be specified either as "mutual," that is, the capacity between two wires of a pair, or as "grounded," that is, the capacity between a wire and all of the other wires and sheath. The mutual capacity is a better criterion of the quality of the cable for telephone transmission, since the conductors are generally used in pairs as a metallic circuit and seldom, if ever, singly as grounded lines. The ratio to grounded capacity is approximately 1:1.6, but this ratio varies somewhat for different cables.

**The purchaser, when requesting prices, should always mention the type of cable wanted or give a full description.**

### Prices

Owing to the fluctuations of the market price of raw material, it is impracticable to list prices on cable in a catalog. We will be pleased, however, to furnish full information and prices on request.

## LEAD-COVERED TELEPHONE CABLE

### Type "TA" Cable

FOR AERIAL OR UNDERGROUND USE

Conductors No. 22 B.&S. Gauge, Single Paper Insulation with Color Groups

Characteristics per Mile of Cable

Average <i>mutual</i> D.C. capacity not greater than.....	.070 microfarad
Approximate equivalent grounded capacity.....	.110 microfarad
Insulation resistance not less than.....	500 megohms
Dielectric strength. Insulation capable of withstanding.....	500 volts D.C.

#### Lead-antimony Sheath

Transmission is equivalent to 1.53 miles of Standard No. 19 B.&S. gauge cable having a mutual electrostatic capacity of .054 microfarad, and 88 ohms resistance, per mile.

#### DETAILS OF TYPE "TA" CABLE

Code No.	No. of Pairs	Thickness of Sheath Inch	Mean Outside Diameter Inches	Approx. Weight per Ft. Lbs.	Convenient No. of Feet on Reel	Color Groups Location in Cable						Tracer Pairs	
						Core	Wire				5th		6th
							2d	3d	4th	Mate			
						Gray	Gray	Gray	Gray	Blue	Green	Red	Orange
TA- 5	5	1/12	7/16	.50	2500	4	..	..	..	..	..	..	} One near Center
TA- 10	10	1/12	17/32	.65	2500	9	..	..	..	..	..	..	
TA- 15	15	1/12	19/32	.75	2500	14	..	..	..	..	..	..	
TA- 20	20	1/12	21/32	.86	2500	19	..	..	..	..	..	..	
TA- 25	25	1/12	23/32	.97	2500	24	..	..	..	..	..	..	
TA- 30	30	1/12	3/4	1.03	2500	29	..	..	..	..	..	..	
TA- 40	40	1/12	27/32	1.20	2000	39	..	..	..	..	..	..	
TA- 50	50	1/12	29/32	1.33	2000	49	..	..	..	..	..	..	
TA- 55	55	1/12	15/16	1.39	1500	54	..	..	..	..	..	..	
TA- 60	60	1/12	31/32	1.46	1500	59	..	..	..	..	..	..	
TA- 75	75	1/12	1-1/16	1.65	1500	74	..	..	..	..	..	..	
TA -90	90	1/12	1-5/32	1.85	1500	89	..	..	..	..	..	..	
TA-100	100	3/32	1- 7/32	2.13	1500	49	49	..	..	..	..	..	
TA-110	110	3/32	1- 9/32	2.27	1200	54	54	..	..	..	..	..	
TA-120	120	3/32	1-11/32	2.41	1200	59	59	..	..	..	..	..	
TA-150	150	3/32	1-15/32	2.74	1200	49	50	49	..	..	..	..	
TA-180	180	3/32	1-19/32	3.07	1200	59	60	59	..	..	..	..	
TA-200	200	1/8	1-23/32	4.07	1000	49	50	50	49	..	..	..	
TA-220	220	1/8	1-25/32	4.29	1000	54	55	55	54	..	..	..	
TA-240	240	1/8	1-27/32	4.51	1000	59	60	60	59	..	..	..	
TA-300	300	1/8	2- 1/32	5.17	800	49	50	50	50	50	49	..	
TA-330	330	1/8	2- 1/8	5.50	800	54	55	55	55	55	54	..	
TA-360	360	1/8	2- 7/32	5.84	800	59	60	60	60	60	59	..	
TA-400	400	1/8	2- 5/16	6.21	700	99	100	50	50	50	49	..	
TA-440	440	1/8	2- 7/16	6.66	700	109	110	55	55	55	54	..	
TA-480	480	1/8	2- 9/16	7.12	600	119	120	60	60	60	59	..	
TA-500	500	1/8	2- 5/8	7.34	600	99	100	100	100	99	..	..	

## LEAD-COVERED TELEPHONE CABLE

## Type "TB" Cable

## FOR AERIAL OR UNDERGROUND USE

## Conductors No. 19 B.&amp;S. Gauge, Single Paper Insulation with Color Groups

## Characteristics per Mile of Cable

Average <i>mutual</i> D.C. capacity not greater than.....	.076 microfarad
Approximate equivalent grounded capacity.....	.120 microfarad
Insulation resistance not less than.....	500 megohms
Dielectric strength. Insulation capable of withstanding.....	500 volts D.C.

## Lead-antimony Sheath

Transmission is equivalent to 1.13 miles of Standard No. 19 B.&S. gauge cable having a mutual electrostatic capacity of .054 microfarad, and 88 ohms resistance, per mile.

## DETAILS OF TYPE "TB" CABLE

Code No.	No. of Pairs	Thickness of Sheath Inch	Mean Outside Diameter Inches	Approx. Weight per Ft. Lbs.	Convenient No. of Feet on Reel	Color Groups Location in Cable						Tracer Pairs
						Core	2d	3d	4th	5th	6th	
						Red	Blue	Orange	Green	Red	Red	
						Wire Mate						
						Gray	Gray	Gray	Gray	Blue	Green	Orange
TB- 5	5	1/12	1/2	.61	2500	4	..	..	..	..	..	One near Center
TB- 10	10	1/12	5/8	.81	2500	9	..	..	..	..	..	
TB- 15	15	1/12	23/32	.98	2500	14	..	..	..	..	..	
TB- 20	20	1/12	25/32	1.11	2000	19	..	..	..	..	..	
TB- 25	25	1/12	27/32	1.23	2000	24	..	..	..	..	..	
TB- 30	30	1/12	29/32	1.36	1500	29	..	..	..	..	..	
TB- 40	40	1/12	1- 1/32	1.61	1500	39	..	..	..	..	..	
TB- 50	50	3/32	1- 5/32	2.01	1500	49	..	..	..	..	..	
TB- 55	55	3/32	1- 3/16	2.10	1200	54	..	..	..	..	..	
TB- 60	60	3/32	1- 7/32	2.19	1200	59	..	..	..	..	..	
TB- 75	75	3/32	1-11/32	2.51	1200	74	..	..	..	..	..	
TB- 90	90	3/32	1-15/32	2.83	1200	89	..	..	..	..	..	
TB-100	100	1/8	1-19/32	3.76	900	49	49	..	..	..	..	
TB-110	110	1/8	1-21/32	3.98	900	54	54	..	..	..	..	
TB-120	120	1/8	1-23/32	4.19	900	59	59	..	..	..	..	
TB-150	150	1/8	1- 7/8	4.78	900	49	50	49	..	..	..	
TB-180	180	1/8	2- 1/32	5.36	900	59	60	59	..	..	..	
TB-200	200	1/8	2- 1/8	5.72	700	49	50	50	49	..	..	
TB-220	220	1/8	2- 7/32	6.10	700	54	55	55	54	..	..	
TB-240	240	1/8	2- 5/16	6.46	700	59	60	60	59	..	..	
TB-300	300	1/8	2-17/32	7.45	600	49	50	50	50	50	49	

Telephone Apparatus and Supplies

42

## LEAD-COVERED TELEPHONE CABLE

### Type "TH" Cable

43

#### FOR LONG AERIAL AND UNDERGROUND LINES

**Conductors No. 16 B.&S. Gauge, Single Paper Insulation, Covering on Pairs Colored Blue, Green and Red Paired with Orange**

Two tracer pairs in each length of cable—one near the center and one in the outside layer. Colors of insulation orange and gray.

#### Characteristics per Mile of Cable

Average <i>mutual</i> D.C. capacity not greater than	.074 microfarad
Approximate equivalent grounded capacity	.115 microfarad
Insulation resistance not less than	500 megohms
Dielectric strength. Insulation capable of withstanding	500 volts D.C.

#### Lead-antimony Sheath

Transmission is equivalent to 0.78 mile of Standard No. 19 B.&S. gauge cable having a mutual electrostatic capacity of .054 microfarad, and 88 ohms resistance, per mile.

#### DETAILS OF TYPE "TH" CABLE

Code No.	*Actual No. of Pairs	Thickness of Sheath Inches	Mean Outside Diameter Inches	Approx. Weight per Foot Lbs.	Convenient No. Feet on Reel	Code No.	*Actual No. of Pairs	Thickness of Sheath Inches	Mean Outside Diameter Inches	Approx. Weight per Foot Lbs.	Convenient No. Feet on Reel
TH-15	16	1/8	1- 1/16	2.10	1500	TH-60	61	1/8	1- 3/4	4.26	1000
TH-20	21	1/8	1- 5/32	2.38	1500	TH-100	101	1/8	2- 5/32	5.78	800
TH-25	26	1/8	1- 1/4	2.65	1500	TH-110	111	1/8	2- 1/4	6.14	600
TH-30	31	1/8	1-11/32	2.92	1200	TH-120	121	1/8	2- 3/8	6.57	600
TH-35	36	1/8	1-13/32	3.13	1200	TH-150	152	1/8	2-17/32	7.46	600

\*The actual number of pairs are guaranteed.

### Type "TJ" Cable

#### FOR LONG AERIAL AND UNDERGROUND LINES

**Conductors No. 13 B.&S. Gauge, Single Paper Insulation, Covering on Pairs Colored Blue, Green and Red Paired with Gray**

Two tracer pairs in each length of cable—one near the center and one in the outside layer. Colors of insulation orange and gray.

#### Characteristics per Mile of Cable

Average <i>mutual</i> D.C. capacity not greater than	.074 microfarad
Approximate equivalent grounded capacity	.115 microfarad
Insulation resistance not less than	500 megohms
Dielectric strength. Insulation capable of withstanding	500 volts D.C.

#### Lead-antimony Sheath

Transmission is equivalent to 0.55 mile of Standard No. 19 B.&S. gauge cable having a mutual electrostatic capacity of .054 microfarad, and 88 ohms resistance, per mile.

#### DETAILS OF TYPE "TJ" CABLE

Code No.	*Actual No. of Pairs	Thickness of Sheath Inches	Mean Outside Diameter Inches	Approx. Weight per Foot Lbs.	Convenient No. Feet on Reel	Code No.	*Actual No. of Pairs	Thickness of Sheath Inches	Mean Outside Diameter Inches	Approx. Weight per Foot Lbs.	Convenient No. Feet on Reel
TJ-15	16	1/8	1-11/32	2.93	1200	TJ-50	51	1/8	2-3/16	5.86	900
TJ-25	26	1/8	1-21/32	3.91	1200	TJ-70	71	1/8	2-9/16	7.33	600
TJ-30	31	1/8	1-13/16	4.40	900	TJ-75	76	1/8	2-5/8	7.63	600
TJ-35	36	1/8	1- 7/8	4.74	900						

\*The actual number of pairs are guaranteed.

### Type "TS" Cable

#### FOR AERIAL AND UNDERGROUND USE

**Conductors No. 22 B.&S. Gauge, Single Paper Insulation with Color Groups**

#### Characteristics per Mile of Cable

Average <i>mutual</i> D.C. capacity not greater than	.083 microfarad
Approximate equivalent grounded capacity	.128 microfarad
Insulation resistance not less than	500 megohms
Dielectric strength. Insulation capable of withstanding	500 volts D.C.

#### Lead-antimony Sheath

Transmission is equivalent to 1.66 miles of Standard No. 19 B.&S. gauge cable having a mutual electrostatic capacity of .054 microfarad, and 88 ohms resistance, per mile.

#### DETAILS OF TYPE "TS" CABLE

Code No.	No. of Pairs	Thickness of Sheath Inch	Mean Outside Diameter Inches	Approx. Weight per Ft. Lbs.	Convenient No. of Feet on Reel	Color Groups Location in Cable						Tracer Pairs Red Orange *	
						Core	Wire				5th		6th
							2d	3d	4th	6th			
						Red	Blue	Orange	Green	Red	Red		Mate
TS-600	600	1/8	2 5/8	7.85	600	Gray	Gray	Gray	Gray	Blue	Green	Orange	
						99	100	100	100	100	99	*	

\*Two—one near center and one in outer layer.

## LEAD-COVERED TELEPHONE CABLE

### Type "F" Cable

#### FOR INSIDE CONSTRUCTION

Conductors No. 22 B.&S. Gauge, Double Silk and Single Cotton Insulation, Covering on Pair  
Colored White and Red White

#### Characteristics per Mile of Cable

Insulation resistance..... 100 megohms

#### Pure Lead Sheath

#### DETAILS OF TYPE "F" CABLE

Code No.	No. of Pairs	Mean Outside Diameter Inches	Thickness of Sheath Inches	Approx. Weight per Foot Lbs.	Convenient No. of Feet on Reel	Code No.	No. of Pairs	Mean Outside Diameter Inches	Thickness of Sheath Inches	Approx. Weight per Foot Lbs.	Convenient No. of Feet on Reel
F-5	5	3/8	3/64	.272	2500	F-75	75	15/16	1/16	1.240	1500
F-10	10	7/16	3/64	.343	2500	F-100	100	1 1/16	1/16	1.491	1500
F-15	15	1/2	3/64	.414	2500	F-120	120	1 5/32	1/16	1.685	1200
F-20	20	9/16	3/64	.485	2500	F-150	150	1 9/32	1/16	1.968	1200
F-25	25	19/32	3/64	.533	2500	F-200	200	1 17/32	3/32	3.141	1000
F-30	30	5/8	3/64	.582	2500	F-240	240	1 5/8	3/32	3.488	1000
F-40	40	23/32	3/64	.701	2000	F-250	250	1 11/16	3/32	3.635	1000
F-50	50	13/16	1/16	.991	2000	F-300	300	1 7/8	1/8	4.985	800
F-60	60	7/8	1/16	1.102	1500						

### Type "G" Cable

#### FOR INSIDE CONSTRUCTION

Conductors No. 22 B.&S. Gauge, Double Silk and Single Cotton Insulation, Colored in Accordance With a Standard Color Scheme so that Each Conductor is Distinguishable from Other Conductors in the Cable

#### Characteristics per Mile of Cable

Insulation resistance..... 100 megohms

#### Pure Lead Sheath

#### DETAILS OF TYPE "G" CABLE

Code No.	No. of Pairs	Mean Outside Diameter Inches	Thickness of Sheath Inches	Approximate Weight per Foot Lbs.	Convenient No. of Feet on Reel
G-5	5	3/8	3/64	.272	2500
G-10	10	7/16	3/64	.343	2500
G-15	15	1/2	3/64	.414	2500
G-20	20	9/16	3/64	.485	2500
G-25	25	19/32	3/64	.533	2500
G-30	30	5/8	3/64	.582	2500
G-40	40	23/32	3/64	.701	2000
G-50	50	13/16	1/16	.991	2000

Telephone Apparatus and Supplies

## LEAD COVERED TELEPHONE CABLE

### Type "AP" Cable

Conductors No. 22 B.&S. Gauge, Double Paper Insulation, Covering on Pairs Colored Red and Gray

#### Characteristics per Mile of Cable

Average <i>mutual</i> D.C. capacity not greater than . . . . .	.100 microfarad
Approximate equivalent grounded capacity . . . . .	.155 microfarad
Insulation resistance not less than . . . . .	500 megohms
Dielectric strength. Insulation capable of withstanding . . . . .	500 volts D.C.

#### Pure Lead Sheath

Transmission is equivalent to 1.83 miles of standard No. 19 B.&S. gauge cable having a mutual electrostatic capacity of .054 microfarad, and 88 ohms resistance, per mile.

#### DETAILS OF TYPE "AP" CABLE

Code No.	No. of Pairs	Mean Outside Diameter Inches	Thickness of Sheath Inches	Approx. Weight per Ft. Lbs.	Convenient No. of Ft. on Reel
AP-5	5	13/32	5/64	.429	2500
AP-10	10	15/32	5/64	.528	2500
AP-15	15	17/32	5/64	.628	2500
AP-20	20	9/16	5/64	.690	2500
AP-25	25	19/32	5/64	.751	2500
AP-30	30	21/32	5/64	.851	2500
AP-40	40	23/32	5/64	.975	2000
AP-50	50	25/32	5/64	1.098	2000
AP-60	60	13/16	5/64	1.183	1500
AP-75	75	29/32	5/64	1.369	1500
AP-100	100	1- 1/32	3/32	1.848	1500
AP-150	150	1- 7/32	3/32	2.364	1200
AP-175	175	1- 9/32	3/32	2.574	1200
AP-200	200	1- 3/8	3/32	2.830	1000
AP-250	250	1- 1/2	3/32	3.255	1000
AP-300	300	1-11/16	1/8	4.479	800
AP-400	400	1-29/32	1/8	5.389	700

### Type "AR" Cable

Same as Type "AP" cable except single instead of double paper insulation.

#### DETAILS OF TYPE "AR" CABLE

Code No.	No. of Pairs	Mean Outside Diameter Inches	Thickness of Sheath Inches	Approx. Weight per Foot Lbs.	Convenient No. of Feet on Reel
AR-5	5	3/8	5/64	.390	2500
AR-10	10	15/32	5/64	.526	2500
AR-15	15	1/2	5/64	.587	2500
AR-20	20	17/32	5/64	.648	2500
AR-25	25	19/32	5/64	.747	2500
AR-30	30	5/8	5/64	.807	2500
AR-40	40	11/16	5/64	.929	2000
AR-50	50	3/4	5/64	1.052	2000
AR-60	60	25/32	5/64	1.134	1500
AR-75	75	7/8	5/64	1.318	1500
AR-100	100	1-0	3/32	1.784	1500
AR-150	150	1- 3/16	3/32	2.291	1200
AR-175	175	1- 1/4	3/32	2.497	1200
AR-200	200	1- 5/16	3/32	2.703	1000
AR-250	250	1- 7/16	3/32	3.120	1000
AR-300	300	1- 5/8	1/8	4.304	800
AR-400	400	1-27/32	1/8	5.196	800

## LEAD COVERED TELEPHONE CABLE

### Type "P" Cable

Conductors No. 22 B.&S. Gauge, Double Paper Insulation, Covering on Pairs Colored  
Red and White

#### Characteristics per Mile of Cable

Average <i>mutual</i> D.C. capacity not greater than .....	.08 microfarad
Approximate equivalent grounded capacity .....	.125 microfarad
Insulation resistance not less than .....	500 megohms
Dielectric strength. Insulation capable of withstanding .....	500 volts D.C.

#### Pure Lead Sheath

Transmission is equivalent to 1.63 miles of standard No. 19 B.&S. gauge cable having a mutual electrostatic capacity of .054 microfarad, and 88 ohms resistance, per mile.

#### DETAILS OF TYPE "P" CABLE

Code No.	No. of Pairs	Mean Outside Diameter Inches	Thickness of Sheath Inches	Approx. Weight per Foot Lbs.	Conven- ient No. of Feet on Reel
P-5	5	7/16	1/12	.503	2500
P-10	10	1/2	1/12	.609	2500
P-15	15	9/16	1/12	.715	2500
P-20	20	5/8	1/12	.819	2500
P-25	25	21/32	1/12	.885	2500
P-30	30	23/32	1/12	.990	2500
P-40	40	13/16	1/12	1.161	2000
P-50	50	7/8	1/12	1.292	2000
P-60	60	15/16	1/12	1.421	1500
P-75	75	1- 1/32	1/12	1.616	1500
P-100	100	1- 3/16	3/32	2.091	1500
P-150	150	1-13/32	3/32	2.661	1200
P-175	175	1- 1/2	3/32	2.922	1200
P-200	200	1-21/32	1/8	3.968	1000
P-250	250	1-13/16	1/8	4.525	1000
P-300	300	1-31/32	1/8	5.073	800
P-400	400	2- 7/32	1/8	6.061	700

### Type "R" Cable

Same as Type "P" cable except single instead of double paper insulation.

#### DETAILS OF TYPE "R" CABLE

Code No.	No. of Pairs	Mean Outside Diameter Inches	Thickness of Sheath Inches	Approx. Weight per Foot Lbs.	Conven- ient No. of Feet on Reel
R-5	5	7/16	1/12	.502	2500
R-10	10	1/2	1/12	.607	2500
R-15	15	9/16	1/12	.711	2500
R-20	20	5/8	1/12	.815	2500
R-25	25	21/32	1/12	.880	2500
R-30	30	11/16	1/12	.944	2500
R-40	40	25/32	1/12	1.112	2000
R-50	50	27/32	1/12	1.240	2000
R-60	60	29/32	1/12	1.368	1500
R-75	75	1	1/12	1.561	1500
R-100	100	1- 3/16	3/32	2.071	1500
R-150	150	1- 3/8	3/32	2.586	1200
R-175	175	1- 7/16	3/32	2.794	1200
R-200	200	1-19/32	1/8	3.805	1000
R-250	250	1-25/32	1/8	4.412	1000
R-300	300	1-29/32	1/8	4.890	800
R-400	400	2- 3/16	1/8	5.917	700

## LEAD-COVERED TELEPHONE CABLE

### Type "SA" Cable

#### FOR UNDERGROUND USE

#### Conductors No. 22 B.&S. Gauge, Single Paper Insulation with Color Groups

#### Characteristics per Mile of Cable

Average <i>mutual</i> D.C. capacity not greater than . . . . .	.090 microfarad
Approximate equivalent grounded capacity. . . . .	.140 microfarad
Insulation resistance not less than . . . . .	500 megohms
Dielectric strength. Insulation capable of withstanding. . . . .	500 volts D.C.

#### Lead-Antimony Sheath

Transmission is equivalent to 1.73 miles of Standard No. 19 B.&S. Gauge cable having a mutual electrostatic capacity of .054 microfarad, and 88 ohms resistance, per mile.

#### DETAILS OF TYPE "SA" CABLE

Code No.	No. of Pairs	Thickness of Sheath Inches	Mean Outside Diameter Inches	Approx. Weight per Ft. Lbs.	Conven- ient No. of Feet on Reel
SA-400	400	1/8	1-27/32	5.085	700
SA-440	440	1/8	1-29/32	5.382	700
SA-480	480	1/8	2	5.753	600
SA-500	500	1/8	2- 1/32	5.901	600
SA-600	600	1/8	2- 3/16	6.653	600
SA-900	900	1/8	2- 5/8	8.856	600

#### Color Groups of Type "SA" Cable

Code No.	Location in Cable									
	Core	2d	3d	4th	5th	6th	7th	8th	9th	Tracer Pairs
	Wire									
	Red	Blue	Orange	Green	Red	Red	Red	Blue	Orange	Red
	Mate									
	Gray	Gray	Gray	Gray	Blue	Green	Gray	Gray	Gray	Orange
SA-400	99	100	50	50	50	49				
SA-440	109	110	55	55	55	54				
SA-480	119	120	60	60	60	59				
SA-500	99	100	100	100	99					
SA-600	99	100	100	100	100	99				
SA-900	99	100	100	100	100	100	100	100	99	

}

Two—  
One near  
Center  
and one  
in outer  
layer

## LEAD-COVERED TELEPHONE CABLE

### Special Cables

Special conditions often require cables with different characteristics from those which have been standardized and coded. There is a Western Electric cable to meet every requirement. If your condition necessitates special cable write our nearest house giving full details and information and price will be furnished. A brief description of some of the most important of special cables is given below:

### Submarine Cables

Paper insulated submarine telephone cable may be divided into three general classes, depending upon the use for which they are intended.

1. High dielectric strength, tight core cable, designed for use in rather long lengths, that is, in lengths such that the cost of repairing a break in the cable will be less than the cost of an entirely new cable.

2. High dielectric strength, loose core cable, designed for use in rather short lengths where high transmission efficiency and high dielectric strength are of importance; for example: a short river crossing cable connecting important open wire lines.

3. Single paper insulated loose core cable designed for use in rather short lengths where so high a dielectric strength is not necessary; for example: a short river crossing cable connecting land cables.

Either single or double armored cable can be furnished. In most cases, the single armored cable is sufficient mechanical protection. The double armored cable is used only in cases of extremely severe mechanical requirements. In still water with a mud bottom, single armor will be sufficient. With a rocky and uneven bottom with strong tides and currents, double armor should be considered.

### Composite Cables

Composite cable, or cable composed of conductors of two or more gauges can be furnished. The combinations of pairs which will utilize the space within the lead sheath most economically are somewhat limited and our cable engineers will make recommendations along this line upon receipt of detail information as to the conditions to be met.

### 1200 Pair Cables

A 1200 pair No. 24 gauge cable has been developed for underground use with a mean outside diameter of  $2\frac{3}{4}$  inches. This type of cable is designed for short cables in congested districts.

### High Dielectric Strength Cables

Paper insulated cable designed to withstand potentials up to 1500 volts A.C. is manufactured for use where telegraph or signal circuits are to be carried through the cable.

### Wool Cables

The general practice of terminating paper insulated cable in the past has been to splice on a short piece of wool insulated cable. It has been found, however, that double silk and single cotton insulation is satisfactory for this purpose and it is less expensive. Double wool insulation can be furnished, however, if desired.

## "FERRIN" CIRCULAR LOOM CABLES

### Emergency Cable



5 Pair Emergency Cable

This cable is adapted for use in cases of breaks in the line caused by storms, fires, etc., or for temporary construction work, and is used extensively by Telephone and Telegraph Companies.

It can be strung on poles or laid on the ground and will stand extremely hard usage.

It is made in any required number of pairs from 1 to 12, and consists of No. 18 B.&S. gauge stranded, rubber-covered conductors, twisted into pairs and covered with a serving of tape after a jute filler has been applied to fill up the spaces between the wires and give the cable the desired roundness. Over this covering of tape is woven a circular loom of heavy cotton, impregnated with a weatherproof compound.

This cable is very pliable and easily handled. It can be furnished on reels provided with stands for unwinding, if desired.

#### Emergency Cable—No. 18 B.&S. Gauge, Stranded Conductors

Number of Pairs	List Price per Foot	Number of Pairs	List Price per Foot
1	\$0.17	5	\$0.68
2	.27	7	.84
3	.41	10	1.02
4	.54	12	1.17



5 Pair Bridle Cable

### Bridle Cable

This cable differs from the emergency cable above described in that it is composed of solid No. 14 B.&S. gauge instead of stranded conductors, with a braiding of cotton over the rubber insulation of each conductor, and all braiding, including the jute filler, impregnated with a weatherproof preservative compound.

This cable is recommended for use in railway service, mines and other locations where a cable with a lead sheath cannot be used on account of destructive chemical properties present in the air or moisture, or where it is frequently disturbed or roughly handled.

#### Bridle Cable—No. 14 B.&S. Gauge, Solid Conductor

Number of Pairs	List Price per Foot	Number of Pairs	List Price per Foot
1	\$0.24	6	\$0.84
2	.39	7	.92
3	.51	8	.99
4	.63	9	1.08
5	.75	10	1.13

## SWITCHBOARD CABLE Cable with Dry Core

### Lead Taped

The conductors are provided with double silk and single cotton insulation, which is colored in such a way that each pair and each single wire can be identified. The cable is protected from injury by a layer of lead tape and a heavy braiding which encloses the conductors. The cable is given a heavy coat of gray fireproofing paint.



No. 123



No. 84

Code No.	Number of Pairs	Number of Singles	Size Inches	Shape	List Price per 100 Ft.
16	20-No. 22	20-No. 22	$\frac{11}{16}$ x $\frac{1}{8}$	Oval	\$33.00
24	20-No. 22	.....	$\frac{11}{16}$ x $\frac{11}{16}$	Oval	24.80
35	25-No. 22	.....	$\frac{3}{4}$ x $\frac{11}{16}$	Oval	31.00
50	10-No. 22	10-No. 22	$\frac{11}{16}$ x $\frac{11}{16}$	Oval	21.10
60	36-No. 22	.....	$\frac{11}{16}$ x $\frac{11}{16}$	Oval	40.90
62	30-No. 22	.....	$\frac{11}{16}$ x $\frac{1}{8}$	Oval	36.00
65	25-No. 19	.....	$\frac{7}{8}$ x $\frac{1}{8}$	Oval	38.40
70	40-No. 22	.....	$\frac{7}{8}$ x $\frac{11}{16}$	Oval	45.80
72	.....	10-No. 19	$\frac{11}{16}$	Round	11.20
74	.....	20-No. 22	$\frac{3}{8}$	Round	13.60
79	10-No. 22	.....	$\frac{1}{2}$ x $\frac{1}{8}$	Oval	14.90
81	5-No. 22	.....	$\frac{1}{8}$ x $\frac{7}{8}$	Oval	9.90
84	20-No. 22	20-No. 22	$1\frac{1}{16}$ x $\frac{11}{16}$	Flat	40.90
98	64-No. 22	32-No. 22	$\frac{3}{4}$ x $1\frac{1}{4}$	Oval	86.60
100	40-No. 24	.....	$\frac{1}{8}$ x $\frac{11}{16}$	Oval	39.60
102	40-No. 24	20-No. 24	$\frac{1}{2}$ x $\frac{11}{16}$	Oval	47.00
103	20-No. 24	.....	$\frac{3}{8}$ x $\frac{1}{8}$	Oval	19.00
106	40-No. 22	20-No. 22	1 x $\frac{1}{8}$	Oval	54.50
107	39-No. 22	19-No. 22 } 4-No. 16 }	$1\frac{1}{2}$ x $\frac{1}{8}$	Oval	59.40
115	20-No. 19	20-No. 22	$\frac{11}{16}$ x $\frac{1}{8}$	Oval	47.00
116	20-No. 19	.....	$\frac{1}{8}$ x $\frac{3}{8}$	Oval	37.00
117	20-No. 19 } 20-No. 22 }	.....	$\frac{11}{16}$ x $\frac{1}{2}$	Oval	56.90
119	50-No. 19	.....	$\frac{3}{4}$ x $1\frac{1}{8}$	Oval	85.40
120	20-No. 24	20-No. 24	$\frac{3}{8}$ x $\frac{11}{16}$	Oval	28.50
121	10-No. 19 } 10-No. 22 }	10-No. 22	$\frac{1}{8}$ x $\frac{3}{4}$	Oval	35.90
*122	10-No. 22 } 1-No. 14 }	.....	* $\frac{1}{8}$	Round	19.80
*123	20-No. 22 } 1-No. 14 }	.....	* $\frac{11}{16}$	Round	31.00
*124	30-No. 22 } 1-No. 14 }	.....	* $\frac{5}{8}$	Round	40.90
125	10-No. 19	.....	$\frac{11}{16}$ x $\frac{1}{8}$	Oval	21.10
126	10-No. 19 } 10-No. 22 }	.....	$\frac{3}{8}$ x $\frac{3}{4}$	Oval	31.00
127	10-No. 19	10-No. 22	$\frac{3}{8}$ x $\frac{11}{16}$	Oval	26.00
168	20-No. 22	20-No. 22	$\frac{7}{8}$ x $\frac{11}{16}$	Oval	\$47.00

\*Furnished with lead covering when so specified. When furnished with lead covering diameter is increased  $\frac{1}{16}$  inch.

## SWITCHBOARD CABLE

### Cable with Beeswaxed Core

#### NOT LEAD TAPED

The conductors are provided with double silk and single cotton insulation, which is colored in such a way that each pair and each single wire can be identified. The cable is then impregnated with beeswax and is covered with servings of paper and a heavy braiding, which is given a heavy coat of gray fireproofing paint.

Code No.	No. of Pairs 22 B.&S. Gauge	Size Inches	Shape	List Price per 100 Feet
143	20	$\frac{1}{16} \times \frac{1}{16}$	Oval	\$26.00
144	30	$\frac{3}{32} \times \frac{1}{16}$	Oval	38.40
*145	50	$\frac{3}{4}$	Round	59.40
146	100	$1\frac{1}{8}$	Round	111.40
147	40	$\frac{7}{8} \times \frac{1}{16}$	Oval	49.50
177	55	$\frac{7}{8}$	Round	65.60

\*Furnished with lead covering when so specified in order.

## Cable with Rubber Insulated Conductors

#### NOT LEAD TAPED

Conductors are rubber insulated and covered with a cotton braid, colored in such a way that each pair and single wire can be identified.

Code No.	No. of Pairs 20 B.&S. Gauge	Size Inches	Shape	List Price per 100 Feet
179	6	$\frac{5}{8}$	Round	\$31.00
180	8	$\frac{3}{4}$	Round	39.60
181	11	$\frac{7}{8}$	Round	52.00



No. 6084

## Cable with Black Enameled Conductors

#### DRY CORE—LEAD TAPED—BRAIDED

The following switchboard cables are composed of black enamel covered conductors covered with two servings or layers of cotton which are colored in such a manner that each pair and single conductor can be identified.

The cable is thoroughly protected by a layer of lead tape and a heavy braiding which is given a heavy coat of gray fireproofing paint.

Code No.	No. of Pairs 22 B.&S. Gauge	No. of Singles 22 B.&S. Gauge	Size Inches	Shape	List Price per 100 Feet
6016	20	20	$\frac{3}{32} \times \frac{1}{16}$	Oval	\$30.00
6024	20	..	$\frac{1}{16} \times \frac{1}{16}$	Oval	22.50
6050	10	10	$\frac{1}{16} \times \frac{1}{16}$	Oval	20.30
6060	36	..	$\frac{1}{16} \times \frac{1}{16}$	Oval	37.00
6062	30	..	$\frac{3}{32} \times \frac{1}{16}$	Oval	32.60
6066	50	..	$\frac{3}{4}$	Round	51.80
6069	100	..	$1\frac{1}{8}$	Round	95.30
6070	40	..	$\frac{7}{8} \times \frac{1}{16}$	Oval	40.90
6074	..	20	$\frac{3}{8}$	Round	12.40
6079	10	..	$\frac{1}{2} \times \frac{1}{16}$	Round	13.60
6081	5	..	$\frac{1}{16} \times \frac{1}{16}$	Oval	9.50
6084	20	20	$1\frac{1}{16} \times \frac{1}{16}$	Oval	36.00
6087	16	..	$\frac{1}{16} \times \frac{1}{16}$	Oval	21.10
6106	40	20	$1 \times \frac{1}{16}$	Oval	49.50
6107	39	23	$1\frac{1}{16} \times \frac{1}{16}$	Oval	54.50
6143	20	..	$\frac{1}{16} \times \frac{1}{16}$	Oval	23.50
6144	30	..	$\frac{3}{32} \times \frac{1}{16}$	Oval	34.70
6145	50	..	$\frac{3}{4}$	Round	54.50
6147	40	..	$\frac{7}{8} \times \frac{1}{16}$	Oval	44.60
6157	18	..	$\frac{1}{16}$	Round	36.30
6178	102	..	$1\frac{1}{8}$	Round	95.30

## INTER-PHONE CABLE

The conductors are provided with double silk and single cotton insulation, which is colored in such a way that each pair and each single wire can be identified. The cable is then impregnated with a wax compound and is covered with servings of paper and a heavy braiding, which is given a heavy coat of fireproofing paint.

The impregnation with wax prevents the insulation from fraying when the cables are installed. It also serves to protect the formed ends against moisture.

Three general types of cable are provided. Each type has its particular use, and care should be taken to order the proper cable for any desired purpose. These types are as follows:

1. *Interior cable with outside braiding treated with gray fireproofing paint. Use only in dry places.*

2. *Interior cable with green glazed cotton outside braiding. Use only in dry places where exposed to view.*

3. *Outside cable, lead covered. Always use this cable outside, and inside in every case where there is apt to be moisture even in a small degree.*

Lead-covered cables are not listed with separate Code Nos. Any fireproofed type of cable may be ordered with a lead sheath.

All cables are provided with a standard color scheme, so that each pair can be distinguished from any other. The pairs are properly twisted to prevent inductive disturbances.

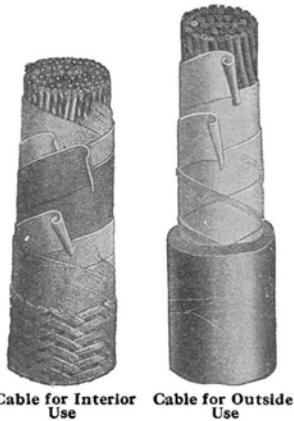

Code No.	Conductors B.&S. Gauge	Covering	Approx. Outside Diameter	List Price per 100 Feet
161	8 singles No. 22	Fireproofed braid	$\frac{1}{16}$ in.	\$11 60
161 (Lead)	8 singles No. 22	Lead sheath	$\frac{1}{16}$ in.	21.00
142	8 singles No. 22	Green cotton braid	$\frac{1}{16}$ in.	9 90
162	12 singles No. 22	Fireproofed braid	$\frac{1}{12}$ in.	14.90
162 (Lead)	12 singles No. 22	Lead sheath	$\frac{3}{16}$ in.	22.70
163	12 singles No. 22	Green cotton braid	$\frac{1}{8}$ in.	19.80
164	6 singles No. 22, 2 pair No. 16	Fireproofed braid	$\frac{1}{8}$ in.	25.20
164 (Lead)	6 singles No. 22, 2 pair No. 16	Lead sheath	$\frac{1}{8}$ in.	28.90
165	6 singles No. 22, 2 pair No. 16	Green cotton braid	$\frac{3}{16}$ in.	26.40
134	6 pair No. 22, 2 pair No. 16	Fireproofed braid	$\frac{1}{8}$ in.	24.80
134 (Lead)	6 pair No. 22, 2 pair No. 16	Lead sheath	$\frac{7}{16}$ in.	33.30
155	6 pair No. 22, 2 pair No. 16	Green cotton braid	$\frac{1}{8}$ in.	26 40
141	12 pair No. 22, 2 pair No. 16	Fireproofed braid	$\frac{1}{8}$ in.	31.40
141 (Lead)	12 pair No. 22, 2 pair No. 16	Lead sheath	$\frac{1}{2}$ in.	43.50
156	12 pair No. 22, 2 pair No. 16	Green cotton braid	$\frac{7}{16}$ in.	38.40
157	16 pair No. 22, 2 pair No. 16	Fireproofed braid	$\frac{1}{8}$ in.	38.00
157 (Lead)	16 pair No. 22, 2 pair No. 16	Lead sheath	$\frac{1}{8}$ in.	50.50
159	16 pair No. 22, 2 pair No. 16	Green cotton braid	$\frac{1}{8}$ in.	42.90
158	20 pair No. 22, 2 pair No. 16	Fireproofed braid	$\frac{9}{16}$ in.	44.60
158 (Lead)	20 pair No. 22, 2 pair No. 16	Lead sheath	$\frac{1}{2}$ in.	60.90
160	20 pair No. 22, 2 pair No. 16	Green cotton braid	$\frac{1}{8}$ in.	49.50
136	24 pair No. 22, 2 pair No. 16	Fireproofed braid	$\frac{1}{8}$ in.	51.20
136 (Lead)	24 pair No. 22, 2 pair No. 16	Lead sheath	$\frac{5}{8}$ in.	63.00
150	24 pair No. 22, 2 pair No. 16	Green cotton braid	$\frac{1}{8}$ in.	51.60
140	31 pair No. 22, 2 pair No. 16	Fireproofed braid	$\frac{5}{8}$ in.	59.40

Telephone Apparatus and Supplies

52

## CABLE TERMINALS

### No. 8 Type

#### WITHOUT PROTECTORS

This terminal is for open wire distribution from lead-covered aerial cable, and is arranged for attaching to poles. No arrangement is made for protective devices. A six-foot No. 22 B.&S. gauge cable stub is standard, and will be furnished attached to assembled terminal, unless otherwise ordered.

Prices are F. O. B. Hawthorne, Ill.



No. 8 Type—  
Cable Terminal  
Open

Code No.	Capacity Pairs	Overall Height (Less Cable Stub)	Diameter of Hood Inches	List Price Each with 6 Ft. No. 22 B.&S. Gauge Cable Attached
8A	10	15 $\frac{3}{8}$	6 $\frac{1}{4}$	\$6.70
8B	16	15 $\frac{3}{8}$	6 $\frac{1}{4}$	7.50
8C	26	19 $\frac{1}{4}$	6 $\frac{1}{4}$	10.60
8D	31	19 $\frac{1}{4}$	6 $\frac{1}{4}$	12.10
8E	51	28 $\frac{1}{4}$	6 $\frac{1}{4}$	17.30

### No. 14 Type

#### WITHOUT PROTECTORS

This is for open wire distribution from lead-covered aerial cable, and is intended to be mounted on poles or buildings. No arrangement is made for protective devices. A six-foot No. 22 B.&S. gauge cable stub is standard, and will be furnished attached to assembled terminal, unless otherwise ordered.

Prices are F. O. B. Hawthorne, Ill.



Closed Open  
No. 14C—Cable Terminal

Code No.	Capacity Pairs	Length Including Nipples	Width of Cover Inches	List Price Each with 6 Ft. No. 22 B.&S. Gauge Cable Attached
14B	11	10 $\frac{3}{8}$	7 $\frac{1}{8}$	\$8.70
14C	16	12 $\frac{3}{8}$	7 $\frac{1}{8}$	10.80
14D	26	17 $\frac{3}{8}$	7 $\frac{1}{8}$	16.70

### No. 15 Type

#### ARRANGED FOR PROTECTORS

For joining aerial and underground cables. No. 77B protectors consisting of 7 ampere fuses, 20 pairs per strip, can be mounted in them, but are not furnished unless ordered. No provision is made for open space cutouts. Bottom of box is removable so that the cables may be put in from the front. These boxes are for mounting on poles, and are inconspicuous because of their narrow width.

Prices are F. O. B. Hawthorne, Ill.

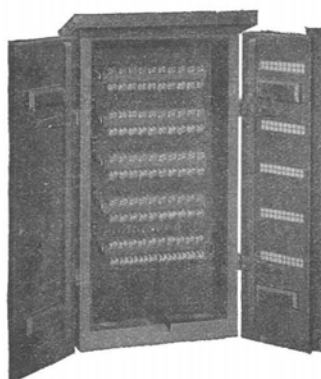

No. 15A Cable Terminal  
Open, with Protectors

Code No.	Capacity Pairs	Dimensions, Inches			List Price Each, without Protectors
		Height	Width	Depth	
15A	100	38	20	11 $\frac{3}{8}$	\$19.30
15B	200	63	22	11 $\frac{3}{8}$	28.20

In ordering, specify the code number and number of pairs (in groups of 20) of protectors desired.

## CABLE TERMINALS

### No. 17 Type ARRANGED FOR PROTECTORS

Wooden cable terminals for use on poles at the junction of aerial cable and underground cable, underground cable and open wire, and aerial cable and open wire.

Designed to mount Nos. 1075A or 61B protectors; or No. 17B protectors on Nos. 1D, E or F connecting blocks or on No. 1075A protectors.

In order to provide for cross-connecting a limited number of pairs, the above connecting blocks may be used with Nos. 1075A or 61B protectors.

Protectors and connecting blocks are not furnished unless ordered.

Terminals are provided with fanning strips located for use without connecting blocks, unless otherwise specified in the order.

Provided with flat iron straps to mount on poles.

The bottom of the box is removable so that the cables may be put in from the front.

White squares, on which the numbers of the cable pairs may be marked, are painted on the inner side of the doors.

Prices are F. O. B. Hawthorne, Ill.

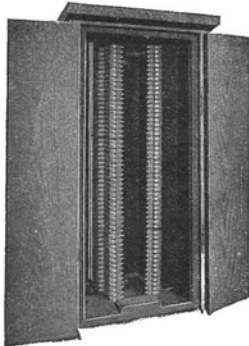

No. 17F Cable Terminal  
Open, with Protectors



Open  
No. 18E Cable Terminal



Closed  
No. 18E Cable Terminal

Telephone Apparatus and Supplies

Code No.	Capacity Pairs	Dimensions, Inches			List Price Each without Protectors
		Height	Width	Depth	
17A	25	44½	15	10⅛	\$12.90
17B	30	51¼	15	10⅛	13.60
17C	50	44¼	22	10⅞	15.40
17E	60	51¼	22	10⅞	16.20
17F	100	78¾	22	10⅞	19.30
17G	110	47¾	38½	11⅞	19.80
17H	120	51¼	38½	11⅞	20.50
17J	150	62¼	38½	11⅞	25.20
17K	200	78¾	38½	11⅞	30.40

### No. 18 Type WITH PROTECTORS

This is a protected terminal for open wire distribution from lead-covered aerial and underground cable. Inclosed in a black finished galvanized iron cover approximately 8⅞ inches in diameter, provided with a safety chain fastened to the mounting base.

Arranged for mounting on poles. Equipped with:

No. 7A fuses (7 ampere unless otherwise specified).

No. 1 protector blocks.

No. 2 protector blocks.

No. 3 protector micas.

A six-foot No. 22 B.&S. gauge cable stub is standard, and will be furnished attached to assembled terminal unless otherwise ordered.

Prices are F. O. B. Hawthorne, Ill.

Code No.	Capacity Pairs	Length Inches	List Price Each Including Cable
18A	10	19⅝	\$19.50
18B	15	22⅜	24.90
18C	25	28⅜	35.70
18D	30	33⅜	47.30
18E	50	46⅜	68.10
18F	60	53⅜	90.40

## CABLE TERMINALS

### No. 12 Type

#### WITHOUT PROTECTORS

A cable terminal consisting of a wooden base and a black finished metal cover, equipped with terminals having solder connections at one end and screw connections at the other.

These terminals are used for interior distribution.

Prices are F. O. B. Hawthorne, Ill.

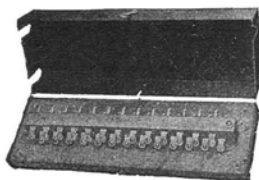

No. 12A. Cable Terminal

Code No.	Capacity in Pairs	—Dimensions, Inches—			List Price Each
		Length	Width	Depth	
12A	13	11 $\frac{1}{8}$	4 $\frac{1}{8}$	1 $\frac{1}{8}$	\$1.80
12B	23	11 $\frac{1}{8}$	4 $\frac{1}{8}$	2 $\frac{1}{8}$	2.30
12C	33	11 $\frac{1}{8}$	4 $\frac{1}{8}$	3 $\frac{1}{8}$	2.90

### No. 19 Type for Inter-Phone Service

#### WITHOUT PROTECTORS

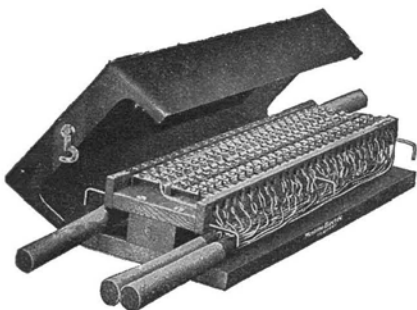

No. 19B. Cable Terminal

The No. 19 Type cable terminal is admirably suited for interior distributing work. It was designed after a great deal of study, and is thought to be the best of its kind on the market. Made of hard wood, numbered and shellacked, and equipped with a black finish sheet metal cover.

Prices are F. O. B. Hawthorne, Ill.

Code No.	Capacity in Pairs	—Dimensions, Inches—			List Price Each
		Length	Width	Depth	
19A	14	8	5 $\frac{1}{8}$	2 $\frac{1}{2}$	\$4.60
19B	26	14	5 $\frac{1}{8}$	2 $\frac{1}{2}$	6.00

### No. 22 Type

A building terminal for use principally in hallways for connecting subscribers lines to house cables. May be used in connection with private branch exchanges.

Consists of a wooden cover and removable wooden backboard. Not arranged for cross connecting.

Arranged for but not equipped with fanning strips and connecting blocks, which are not furnished as a part of the cable terminal, their location in the box depending on the manner in which the wires are brought in.

The cover and exposed ends of the backboard will be furnished with either an oak or a mahogany finish; oak, unless otherwise specified.

When furnished with a mahogany finish, they will be considered special.

Prices are F. O. B. Hawthorne, Ill.

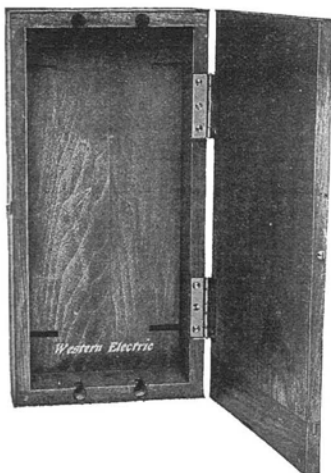

No. 22A. Cable Terminal

Code No.	Capacity in Pairs	Arranged for		—Dimensions, Inches—			List Price Each
		Connecting Blocks	Fanning Strips	Length	Width	Depth	
22A	11	1 No. 6B	1 No. 1	12 $\frac{1}{2}$	6 $\frac{1}{4}$	2 $\frac{5}{8}$	\$1.00
22B	16	1 No. 6C	1 No. 2	16	6 $\frac{1}{2}$	2 $\frac{5}{8}$	1.10
22C	21	1 No. 6D	1 No. 3	21	6 $\frac{3}{4}$	2 $\frac{5}{8}$	1.40
22D	32	2 No. 6C	2 No. 2	16	12	2 $\frac{5}{8}$	2.60
22E	42	2 No. 6D	2 No. 3	21	12 $\frac{1}{2}$	2 $\frac{5}{8}$	2.90

### CALCULAGRAPHS

Furnished in case. Style A, Style B or Style C, as specified.

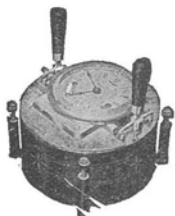

Style B



Style C

Model No.	Description	List Price Each
6	Calculates and prints elapsed time in minutes and quarter minutes, has visible dial, and records the time of day. . . . .	\$170.00
	Pedestal for calculagraph for use with the Style A case, height adjustable from 26 to 40 inches from floor to ticket plate. . . . .	\$17.00
	Ribbon for calculagraph. Unless otherwise ordered, blue is shipped. Other colors made to order. . . . .	\$1.50

F. O. B. New York City.



Style A On Pedestal

### CHAIRS

For telephone switchboard operators. The chairs are furnished in birch with a mahogany finish. They can be furnished with leather over cane, and with castors or rubber tips at slight additional cost.

The first measurement indicates the distance of seat from floor when the seat is in its lowest position, while the second indicates the highest.



Height Inches	List Price Each
18 to 22. . . . .	\$8.50
24 to 31. . . . .	9.00
28 to 35. . . . .	9.50

F. O. B. New York City

### CHURCH TELEPHONES

The Western Electric church telephones are used for the purpose of transmitting the church service, both speaking and musical, to the partially deaf members of the congregation.

#### DESCRIPTION

The equipment consists of a transmitter, placed in the pulpit, and receivers placed in the pews wherever they are needed.

**Transmitter.** An exceedingly sensitive instrument, capable of transmitting the entire church service to receivers located in any of the pews.

**Receivers.** These telephone instruments are designed to give a full volume of tone with clear, understandable enunciation.

For convenience in using, the receivers are equipped with extension lorgnette handles. Their compactness and black finish make them inconspicuous.

Standard equipments are not intended for transmitting to points outside the church building or auditorium.

Prices and further information on request.



Church Telephone Transmitter



Handle Closed

Handle Extended

Church Telephone Receiver  
Telephone Apparatus and Supplies

## CHAU-PHONE

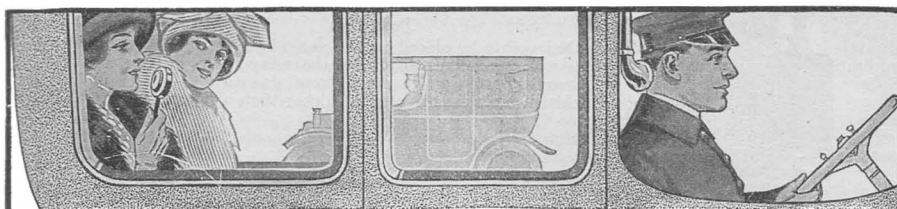

### Chau-phone (Chauffeur Telephone)

#### A Telephone for Limousines or other closed Automobiles

The Western Electric Chau-phone is a telephone equipment for automobiles of the Limousine and Landaulet type for communicating between the passengers and the chauffeur, and takes the place of the old-fashioned and unsanitary speaking-tube.



Trans-  
mitter

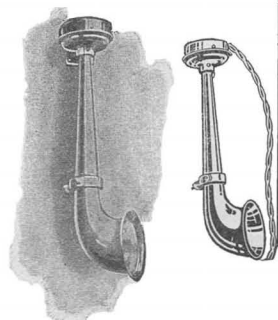

Receiver

#### APPARATUS

The apparatus consists of a transmitter mounted on a handle and a weatherproof loud speaking receiver fitted to a megaphone horn which can be mounted on the framework of the car near the chauffeur's ear. (The receiver is so designed that it is adjustable to cars having either right or left hand drive.) The standard finish is black.

#### OPERATION

Orders spoken into the transmitter in an ordinary conversational tone are delivered to the chauffeur with the tone magnified—loud and clear—above the wind and the street noises, regardless of the speed at which the car is traveling. This eliminates trouble encountered with a speaking tube, as with the latter it is frequently necessary for the chauffeur to slow down the car or drive up to the curb in order to hear the spoken instructions, especially in windy or stormy weather.

#### INSTALLATION

The Chau-phone can be installed as readily on old as on new cars and the wires can be concealed. The regular car batteries—6 or 8 volts—will operate it, and the current required is so small as to be negligible, no current being required while not in use.

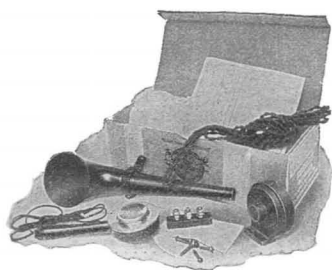

Method of Packing

#### PACKING

Each Chau-phone is put up in a substantial box containing wire and everything else necessary to install it, including illustrated directions.

Chau-phones are used by a large number of leading car and body builders.

Code No.  
1384A

List Price Each  
\$50.00

**The Chau-phone Completes the Luxury of the  
Closed Car.**

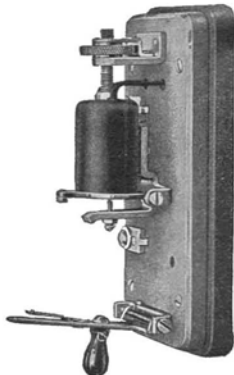

No. 2A Circuit Breaker

**CIRCUIT BREAKER**

Code No.	Description	List Price Each
2A	Designed to be placed in the main battery circuit of train despatching lines to protect the relay and associated apparatus from an excess current due to a short circuit. Much more sensitive and quicker than a fuse.....	\$6.20

**CODE SIGNALING SETS**

See "Mechanical Code Signaling Systems."

**COIL, CONDENSER AND RELAY BOXES**

See "Mechanical Code Signaling Systems."



No. 1A—Connecting Block

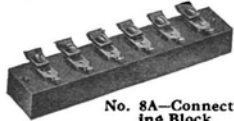

No. 8A—Connecting Block



No. 10A—Connecting Block

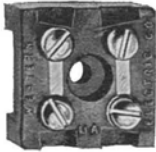

No. 11A—Connecting Block



No. 6D—Connecting Block

**CONNECTING BLOCKS**

Code No.	No. of Binding Posts	Style	Size Inches	Base	List Price Each	
1A	3	Lock nut	2 1/2 x 3/4	Composition	\$0.20	
1D	5	Lock nut	3 1/8 x 3/4	Hard rubber	.70	
1E	10	Lock nut	6 3/8 x 3/4	Hard rubber	1.10	
1F	20	Lock nut	13 3/4 x 3/4	Hard rubber	2.30	
6A	7 prs.	Lock nut	5 5/8 x 1 7/8	Composition	.90	
6B	11 prs.	Lock nut	8 5/8 x 1 7/8	Composition	1.30	
6C	16 prs.	Lock nut	12 3/8 x 1 7/8	Composition	1.70	
6D	21 prs.	Lock nut	16 1/8 x 1 7/8	Composition	2.40	
6E	26 prs.	Lock nut	19 7/8 x 1 7/8	Composition	2.80	
8A	6	For cord tip	5 x 1	Ebonzd. wood	.40	
8D	4	Screw	3 1/2 x 1	Wooden	.70	
8E	8	Screw	5 5/8 x 1 1/8	Wooden	1.30	
8F	12	Screw	8 1/8 x 1 1/8	Wooden	1.50	
10A	7 prs.	Solder and lock nut	4 1/2 x 1 1/8	Composition	1.80	
10B	11 prs.	Solder and lock nut	6 3/4 x 1 1/8	Composition	2.40	
10C	16 prs.	Solder and lock nut	9 9/8 x 1 1/8	Composition	2.90	
10D	21 prs.	Solder and lock nut	12 3/8 x 1 1/8	Composition	3.70	
10E	26 prs.	Solder and lock nut	15 5/8 x 1 1/8	Composition	4.80	
11A	2 prs.	Screw	1 1/8 x 1 3/8	Composition	.17	
11B	2 prs.	Screw	1 3/8 x 1 3/8	Composition	.25	
		(Same as No. 11A except equipped with a cover.)				
12A	3 prs.	Screw	1 1/4 x 1 1/2	Composition	.22	
12B	3 prs.	Screw	1 1/2 x 1 3/8	Composition	.30	
		(Same as No. 12A except equipped with a cover.)				

**CHRONOSCOPE**

For timing telephone calls on toll connection. This instrument is accurate and reliable. Press a lever when the connection is established, another at the end of the call, and there is an accurate record of the time elapsed. Two styles are furnished. Both styles have metal oxidized cases and a six minute clock dial.



Chronoscope

Telephone Apparatus and Supplies

List No	Description	List Price Each
99	A warning bell signal is given a few seconds before one and three minutes have elapsed. Can be stopped at any point.....	\$7.00
99 1/2	Gives the warning signal before three and six minutes. Can be stopped at any point.....	7.00

## COIN COLLECTORS

Electrically Operated—for Central Battery Service Only

### NO. 7 TYPE

These are arranged so that a coin placed in the coin chute remains under control of the central office operator, who may refund or deposit it in the coin box. The coin collector is ordinarily connected to the telephone line so that it is necessary to drop a coin of the proper denomination into the box to signal central office. This saves considerable time on the part of the operator. It may be wired so that the coin need not be deposited until the operator requests it. The switchboard cord circuits must be arranged for operation in connection with these coin collectors.

All electrical circuits are insulated from the case. The case has a heavy black japanned finish.



No. 7J

Code No.	Arranged for	Approx. Dimensions Inches			List Price Each
		Length	Width	Depth	
7J	Nickels	8 <sup>3</sup> / <sub>16</sub>	5 <sup>9</sup> / <sub>16</sub>	4 <sup>7</sup> / <sub>8</sub>	\$10.40
7K	Nickels	11 <sup>1</sup> / <sub>16</sub>	5 <sup>1</sup> / <sub>2</sub>	4 <sup>2</sup> / <sub>2</sub>	10.60

The No. 7K has a larger coin box than the No. 7J.

### NO. 50 TYPE

This coin collector can only be used in central battery systems where the switchboard cord circuits are arranged and wired for this class of coin collector service.

Has slots for nickels, dimes and quarters.

Requires that a coin be deposited before the operator can be called.

If the charge is greater than the amount deposited to signal the operator, the coin so deposited is returned by the operator to the calling party with the request that he deposit the proper amount in the usual manner, or in case of a call involving a charge amounting to the denomination of the coin deposited, it can be deposited in the coin box by the operator at the close of the conversation.

A transmitter, receiver, receiver cord, and desk set box are necessary for a complete station equipment. These items are not included with the coin collector and must be ordered separately. The coin collector is intended for wall mounting, but can be mounted on a desk or shelf by means of a No. 139A back-board. A burglar alarm switch is provided which is operated by the cash compartment lock.

50A Nickels, Dimes and Quarters 18 <sup>1</sup>/<sub>4</sub>                      7                      6                      \$41.60



No. 50A

### The Gray Automatic Pay Station

These coin collectors may be used on either local battery or central battery lines. The signals are given automatically on dropping the coin into the slot. No electrical connections are required.

Code No.	Type	Coins Arranged for	Approx. Size Inches	*List Price
				Each
7	Wall	Nickel, Dime, Quarter	9 x 4 <sup>1</sup> / <sub>2</sub> x 3	\$19.20
8A	Wall	Nickel	7 x 3 <sup>3</sup> / <sub>8</sub> x 3 <sup>1</sup> / <sub>8</sub>	8.40
11	Wall	Nickel, Dime, Quarter	9 x 4 <sup>1</sup> / <sub>2</sub> x 3	19.20
13A	Desk	Nickel	9 <sup>1</sup> / <sub>2</sub> x 3 <sup>1</sup> / <sub>2</sub> x 3 <sup>1</sup> / <sub>4</sub>	13.20
14	Desk	Nickel, Dime, Quarter	11 x 4 <sup>1</sup> / <sub>2</sub> x 3 <sup>1</sup> / <sub>2</sub>	26.40
20	Desk	Nickel, Dime, Quarter	10 <sup>3</sup> / <sub>4</sub> x 4 <sup>1</sup> / <sub>4</sub> x 3 <sup>1</sup> / <sub>4</sub>	25.20

\*F. O. B. Hartford, Conn.

The above code Nos. and prices cover the coin collector box only and do not include telephone instrument.



No. 7 Mounted on a Central Battery Telephone



No. 11 Mounted on a No. 1317 Wall Telephone



No. 14 Mounted with a No. 1020 Desk Stand Telephone Apparatus and Supplies

## COMBINED JACKS AND SIGNALS Ball Type

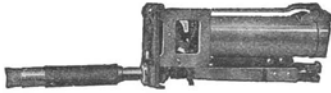

No. 2 Type—Combined Jack and Signal  
on No. 80B Mounting—Single

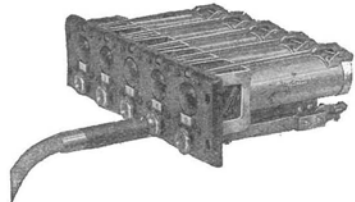

No. 2 Type—Combined Jacks and Signals  
on No. 81E Mounting—5 Per Strip

The Ball Type Combined Jack and Signal is used as a magneto line signal on switchboards where it is desirable that the jack be closely associated with the signal, thereby increasing the ease and rapidity of operating.

The signal consists of a spherical target or ball, painted red and black and pivoted in the center. When in its normal position before the call has come in, the target displays its black surface through an opening in its mounting plate on the face of the switchboard. When the call is received the target automatically rotates so that the red surface instead of the black is exposed, thus indicating to the operator that a call has been sent in.

The target is automatically restored to its normal or black position when the plug is inserted in the jack to answer the call.

The mounting desired should be specified in each order. These Combined Jacks and Signals are furnished un-numbered unless otherwise specified. When so ordered, however, numbers are furnished printed on celluloid face sheets ready to cut up.

**The use of the Shutter Type below described is recommended.**

Be sure, in ordering, to specify which sheet is desired.

Sheet 1 . . . . .	Numbered 0- 99
Sheet 2 . . . . .	Numbered 100-199
Sheet 3 . . . . .	Numbered 200-299
Sheet 4 . . . . .	Numbered 300-399

## Shutter Type

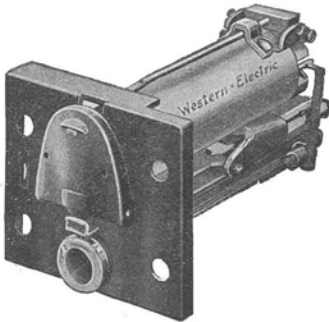

No. 22 Type on No. 92B Mounting  
Signal Restored

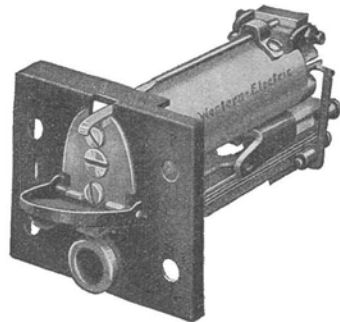

No. 22 Type on No. 92B Mounting  
Signal Operated

This type performs the same service as the Ball Type above described and is also electrically operated and mechanically restored. It differs principally in that a shutter type of drop is used instead of the spherical target as a signal.

The mounting desired should be specified in the order.

Unless otherwise ordered these Combined Jacks and Signals will be furnished un-numbered. However, if specified, metal number plates (0 to 499) will be supplied and should be ordered as P-113032, specifying the numbering required.

**COMBINED JACKS AND SIGNALS**

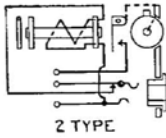

2 TYPE

**No. 2—BALL TYPE**

Code No.	Approximate Resistance Ohms	Plugs Used	Description	Mountings No.	List Price Each
2A	80	47	Has night bell contact, and single cut-off jack. For non-multiple magneto lines.	80B,	\$4.70
2C	240	47		81E or 88B	4.70

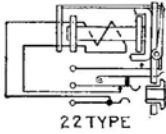

22 TYPE

**No. 22—SHUTTER TYPE**

22A	80	47	Same as No. 2 Ball type.	89B or	\$4.30
22C	350	47		92B	4.30

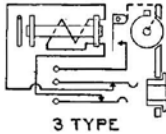

3 TYPE

**No. 3—BALL TYPE**

3A	80	47	Has night bell contact and double cut-off jack. For non-multiple magneto lines.	80B,	\$4.80
3C	240	47		81E or 88B	4.80

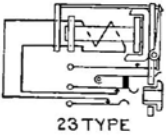

23 TYPE

**No. 23—SHUTTER TYPE**

23A	80	47	Same as No. 3 Ball type.	89B or	\$4.40
23C	350	47		92B	4.40

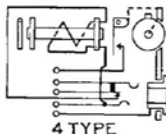

4 TYPE

**No. 4—BALL TYPE**

4A	80	110	Has night bell contact and single cut-off jack. For multiple magneto lines.	80C,	\$4.70
4C	240	110		81F or 88C	4.70

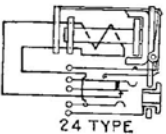

24 TYPE

**No. 24—SHUTTER TYPE**

24A	80	110	Same as No. 4 ball type.	89C,	\$4.30
24C	350	110		92C or 101C	4.30

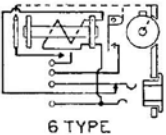

6 TYPE

**No. 6—BALL TYPE**

6A	80	47	Same as No. 2 type except that it has a contact on its armature which closes a local circuit during the ringing interval, providing the audible code signaling feature.	80B,	\$5.20
6C	240	47		81E or 88B	5.20

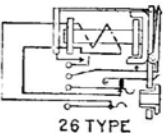

26 TYPE

**No. 26—SHUTTER TYPE**

26A	80	47	Same as No. 6 ball type.	89B or	\$4.70
26C	350	47		92B	4.70

Prices do not include mountings.

## COMBINED JACKS AND SIGNALS

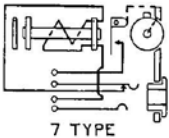
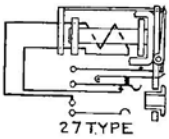
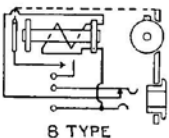
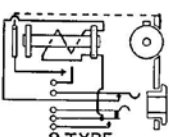
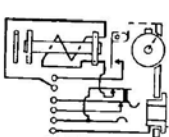
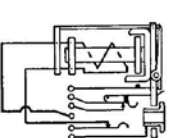
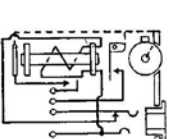
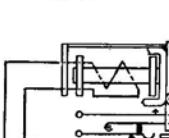
		No. 7—BALL TYPE				
Code No.	Approximate Resistance Ohms	Plugs Used	Description	Mountings No.	List Price Each	
 7 TYPE	7C	240	47	Same as No. 2 type except that one side of the signal winding is brought out to a separate terminal, adapting it to selective central office signaling on bridged party lines.	80B, 81E or 88B	\$4.70
 27A 27C	82 350	47 47	No. 27—SHUTTER TYPE Same as No. 7 ball type.			
 8 TYPE	8D 8J	1150 11½	47 47	No. 8—BALL TYPE Same as No. 6 type except the night bell contact and terminal springs are omitted and a copper wire connector is provided for connecting the frame and the armature. Intended for use in train dispatching circuits. No. 8J used in a local circuit, and operated on .040 ampere direct current.	80B, 81E or 88B	\$5.00 4.70
 9 TYPE	9D	1150	116	No. 9—BALL TYPE Springs so arranged that way station operator's set can be connected to the line and one side of coil winding disconnected by inserting a No. 116 plug. Armature is equipped with a relay contact which is closed only while ringing current flows through the coil. This permits of code signals being received by a bell or buzzer, wired in series with the contact. Intended for use in train dispatching circuits.	80B, 81E or 88B	\$5.90
 11 TYPE	11A 11C	80 240	110 110	No. 11—BALL TYPE Has night bell contact and double cut-off jack. Sleeve of jack is brought out to a separate terminal. For multiple or non-multiple magneto lines.	80C, 81E or 88C	\$5.70 5.70
 31 TYPE	31B 31C	130 350	110 110	No. 31—SHUTTER TYPE Same as No. 11 ball type.	89C, 92C, or 101C	\$5.20 5.20
 12 TYPE	12A 12C	80 240	110 110	No. 12—BALL TYPE Has night bell contact and single cut-off jack. Also has a relay contact on the armature similar to the No. 6 type.	80B, 81E or 88B	\$5.90 5.90
 42 TYPE	42C	330	145	No. 42—SHUTTER TYPE Has night alarm contact and single cut-off jack. Designed to function with the No. 42 Kellogg plug and when mounted on the No. 100 signal mounting will mount interchangeably with a similarly mounted No. 3 Kellogg combined jack and signal.	100	\$4.50

Prices do not include mountings.

### MOUNTINGS FOR COMBINED JACKS AND SIGNALS

(SEE SIGNAL MOUNTINGS)

COMBINED JACKS AND SIGNALS

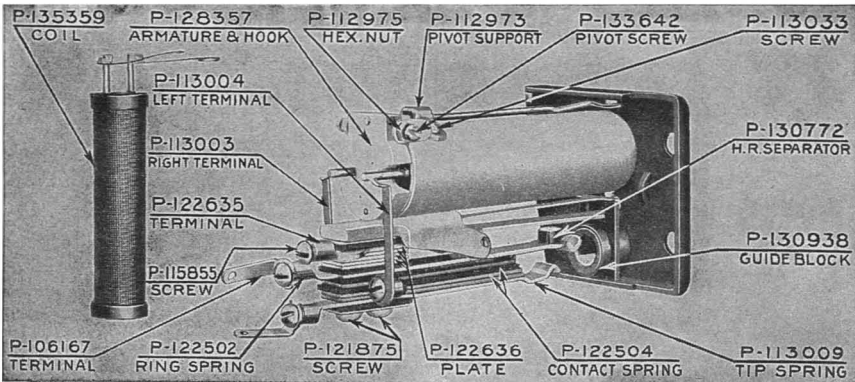
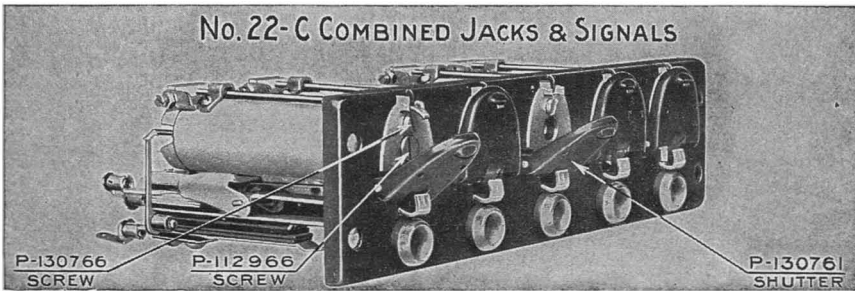
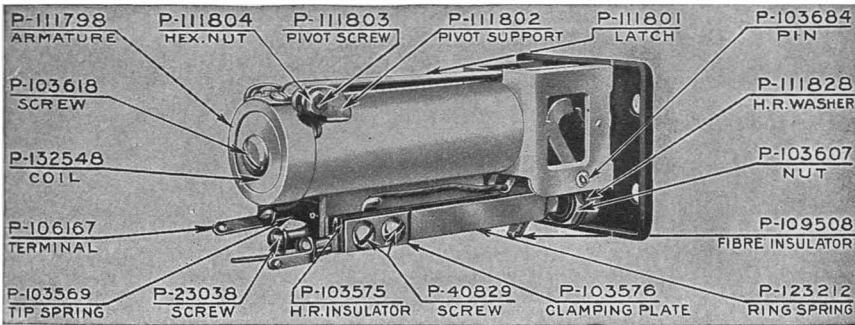

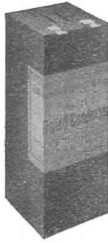

No. 21D



No. 21J



No. 21U

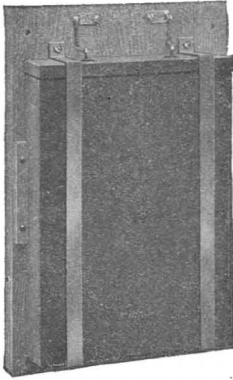

No. 27B Condenser

## CONDENSERS Unmounted

These are of small size and made of selected material. They may be mounted in any desired position by means of a condenser strap (P-43065) and two wood screws. The No. 21E is sometimes mounted by means of strap P-43121.

Code No.	Capacity Microfarads	Style of Terminal	Size of Case Inches	Use	List Price Each
21D	2	Bent	4 7/16 x 1 3/4 x 1 5/8	For telephone sets	\$1.90
21E	2	Straight	4 7/16 x 1 3/4 x 1 5/8	For switchboards and for general use	1.90
21F	1	Bent	4 7/16 x 1 3/4 x 1 5/8	For telephone sets	1.10
21H	0.1	Bent	4 7/16 x 1 3/4 x 1 5/8	For No. 84 type interrupter	1.00
21J	0.33	Straight	4 7/16 x 1 3/4 x 1 5/8	Three terminals	1.30
21K	1	Straight	4 7/16 x 1 3/4 x 1 5/8	For general use	1.10
21L	2	Straight	4 7/16 x 1 3/4 x 1 5/8	For mounting on coil racks	1.90
21M	1	Straight	4 7/16 x 1 3/4 x 1 5/8	For mounting on coil racks	1.10
21N	1	Straight	4 7/16 x 1 3/4 x 1 5/8	For mounting on coil racks—3 terminals	1.80
21R	0.5	Straight	4 7/16 x 1 3/4 x 1 5/8	For general use	.70
21S	0.125 0.250 0.500	Straight	4 7/16 x 1 3/4 x 1 5/8	For telegraph work—4 terminals	1.80
21U	.05	Bent	4 7/16 x 1 3/4 x 1 5/8	For railway composite telephone set	.80
21W*	1	Bent	4 7/16 x 1 3/4 x 1 5/8	For receiver circuit, magneto telephone sets	1.10
21Y	0.25	Bent	4 7/16 x 1 3/4 x 1 5/8	For telegraph work	2.00
21AA	1	Bent	4 7/16 x 1 3/4 x 1 5/8	In telephone train dispatching circuits. Designed to stand 1000 volts A.C.	2.50
21AB	0.125 0.25 0.5	Straight	4 7/16 x 1 3/4 x 1 5/8	As an artificial line in connection with duplex telegraph circuits	2.50
21AC	0.5	Straight	4 7/16 x 1 3/4 x 1 5/8	For No. 1200 switchboard	1.10
21AD	1	Straight	4 7/16 x 1 3/4 x 1 5/8	Composite sets	2.00
21AH	.02 .025 .05	Straight	4 3/8 x 1 3/4 x 2 3/8	Four terminals	1.60
21AK	.5	Bent	4 7/16 x 1 3/4 x 1 5/8	Same as No. 21F except for capacity	1.50
23A	1	Straight	8 3/8 x 6 9/16 x 1 1/2	In No. 27B and 28B condensers for railway composite systems	6.20
31A	0.05 0.05	Wire	4 1/2 x 1 5/8 x 1 1/2	For general use—4 terminals	1.30
35A	2 2		8 1/16 x 6 1/2 x 2 5/8	For mining sets	8.20

\*Equipped with two flexible leads.

## Mounted

These consist of one or more of either No. 21 or No. 23 type condensers mounted on a wood base.

Code No.	Condensers Used	Capacity of Each Condenser Microfarads	Overall Dimensions Inches	Use	List Price Each
27B	1 No. 23A	1	10 7/8 x 7 1/8 x 2 3/16	For railway composite systems	\$7.20
28B*	1 No. 23A	1	10 3/4 x 11 x 8 1/16	For railway composite systems	28.00
33A	2 No. 21L	2	10 3/4 x 1 7/8 x 2 3/8	Arranged for mounting on coil racks	4.20
33B	1 No. 21L	2	10 3/4 x 1 7/8 x 2 3/8	Arranged for mounting on coil racks	2.30
33C	2 No. 21M	1	10 3/4 x 1 7/8 x 1 1/4	Arranged for mounting on coil racks	2.60
33D	1 No. 21M	1	10 3/4 x 1 7/8 x 1 1/4	Arranged for mounting on coil racks	1.50
33E	2 No. 21N	1	10 3/4 x 1 7/8 x 2 3/8	Arranged for mounting on coil racks	3.80
33G	2 No. 21AD	0.5 1	10 3/4 x 1 7/8 x 2 3/8	Arranged for mounting on coil racks	4.70
33H	4 No. 21L	2	10 3/4 x 1 7/8 x 4 1/8	Arranged for mounting on coil racks	8.70
36A	5 No. 21E	2	6 3/4 x 3 1/2 x 5 1/16	For 3x7 cordless P. B. X. switchboards	10.60
37A	3 No. 21E	2	6 3/4 x 1 3/4 x 5 1/16	For 3x7 cordless P. B. X. switchboards	6.20

\*Mounted in a wood box with a No. 48A retardation coil.

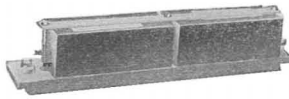

No. 33A

Telephone Apparatus and Supplies

## CONDENSER STRAPS

Code No.	Description	List Price per 100
P-43121	Bent iron strap for use with No. 21E condenser	\$7.50
P-43065	Straight iron strap for use with No. 21 type condensers	4.40

## CORDS

### Foreword

Western Electric telephone cords are the result of more than thirty-eight years' experience in the manufacture of telephone apparatus and are of the same high grade that has characterized Western Electric telephone equipment in general and caused it to be recognized as standard by the leading telephone authorities throughout the world.

They will be found to have exceptional strength and wearing qualities and will stand up longer in service than any other cords manufactured.

There is a Western Electric cord to fit any style or make of telephone or switchboard.

If none of the herein described cords suit your conditions, write our nearest house and tell us what your requirements are. We will then quote you prices on cords that will do your work.

In ordering cords for other than Western Electric equipment, be sure to give full information. If possible, send us an old cord as a sample, and in the case of switchboard cords send a sample of the plug used.

#### INDEX AND CORD CLASSIFICATION

	Page
1. Central Office cords	Switchboard cords . . . . . 67
	Operators' telephone cords . . . . . 68
	Miscellaneous Central Office cords . . . . . 69
2. Telephone set cords	Receiver cords . . . . . 71
	Transmitter cords . . . . . 73
	Desk Stand and Telephone Arm cords . . . . . 72
	Hand set cords . . . . . 73
3. Miscellaneous cords . . . . .	74

### Switchboard Cords

In the past the Western Electric Company's steel switchboard cords for local service have been extremely popular because of their superior construction and long life; tinsel cords, on account of their much shorter life, being used only in toll switchboards where a high grade of transmission was absolutely essential.

For several years our engineers have been engaged in exhaustive studies of different grades of tinsel with the object in view of obtaining a product which, when used in switchboard cords, would maintain the high transmission qualities of this type of cord and at the same time have a service life equal at least to the steel cord.

Our efforts in this direction have been extremely productive, and we now offer a tinsel switchboard cord which is superior both as regards life and transmission qualities to any cord before produced, either steel or tinsel, and is at the same time moistureproofed, which is a wonderful improvement and advantage.

## CORDS

## Switchboard Cords (Continued)

## CONSTRUCTION

The following steps in the construction of these cords may be of interest and show the care exercised in producing a superior cord for all classes of switchboard service:

1. Six tinsel threads are twisted together to form a strand. These tinsel threads used in making up the cord conductors are of special manufacture and are made under the Western Electric Company's own rigid specifications.

2. Three of the above strands are twisted together to form a conductor. It will be noted, therefore, that each conductor contains eighteen threads.

3. Each conductor is covered with two heavy servings or wrappings of Tussah Floss Silk for the purpose of insulating them from each other.

4. These silk insulated conductors are then impregnated with an asphaltic moistureproofing compound. This compound is impervious to moisture, flexible, does not harden with age, and will not cause corrosion.

5. After this moistureproofing is applied each conductor is further protected and insulated with a heavy cotton braiding.

6. These conductors (two or three) are then twisted together to form the body of the cord.

7. The spaces between the conductors so twisted together are then filled with heavy cotton twine. This makes the external surface smooth.

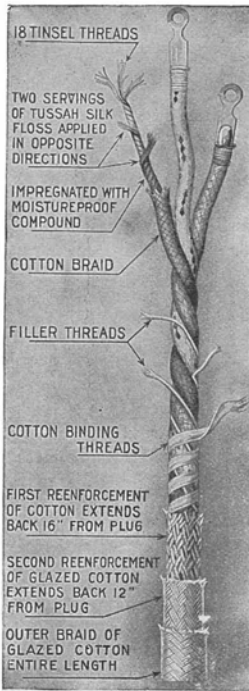

Steps in the Construction of a Western Electric Tinsel Switchboard Cord

8. The body of the cord is then given a tight serving or wrapping of cotton to hold the conductors firmly in place.

9. On the No. 448 and No. 493 cords a braided covering or reinforcement of cotton is then applied for about sixteen inches back from the plug end of the cord, and over this a second reinforcement of glazed cotton is applied for a distance of about twelve inches.

On the No. 447 the inner reinforcement is omitted to permit the use of the No. 109 plug.

10. An outside braiding of glazed cotton is then applied over the entire length of the cord.

It will be noted from the foregoing that in the construction of these cords the individual tinsel threads are first twisted together into strands of six threads each; that three of these strands are twisted together to form a conductor; and that the conductors after being insulated are then twisted together to form the completed cord.

This is the same process observed in the manufacture of manila rope and is the most satisfactory method of cord construction yet devised, both as regards strength and wearing qualities, which has been proven conclusively by long experience in actual service.

Telephone Apparatus and Supplies

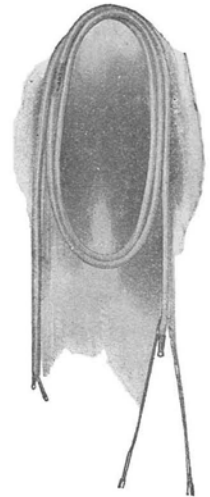

No. 493 Cord

CORDS

Switchboard Cords (Continued)

ADVANTAGES

By laboratory experiments and tests made under actual service conditions the following feature claims on this type of cord have been proven conclusively:

1. The life is much longer (at least 49 per cent.) than any other cord heretofore manufactured by this or any other company.

2. The moistureproofing feature makes it possible to use these cords in damp and humid climates for long periods without the necessity of making frequent changes.

Dampness from the operator's hands has practically no effect on these cords, and the practice of saturating the cords with beeswax to overcome this trouble, which makes them uncomfortable to handle, is unnecessary.

3. They are easier to replug than steel conductor cords.

4. The resistance of each conductor is approximately 1 ohm (6 ft. cord) as compared with an average of 2 to 10 ohms per conductor for the steel cords.

5. The efficiency of the operating force is increased, due to the fact that this type of cord is much more flexible than a steel cord.

6. The current carrying capacity of each conductor is 3 amperes which is much greater than is ever necessary in telephone service.

7. The same cord can be used interchangeably for either toll or local service, and it is not necessary to maintain two stocks of cords.

Cords having either *white, red, green or black braiding* can be furnished. If no color is specified, however, white cords will be furnished.

In ordering cords be sure to specify length, observing standard stock lengths as listed.

If cords are desired equipped with plugs, it should be so specified in the order together with Code No. of plug.

When ordering cords for use with switchboards of other than Western Electric manufacture, specify cord-tips desired and send sample or manufacturer's name and Code No. of plug.

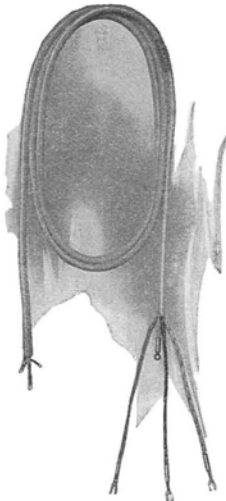

No. 447 Cord

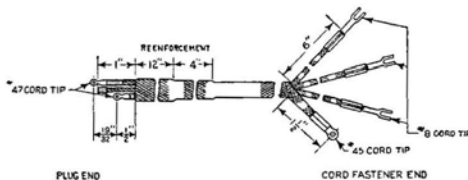

No. 448

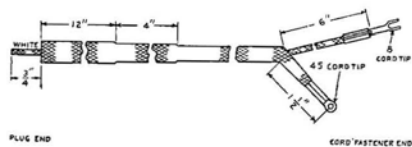

No. 511

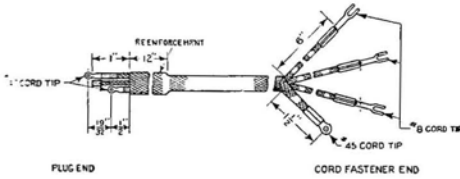

No. 447

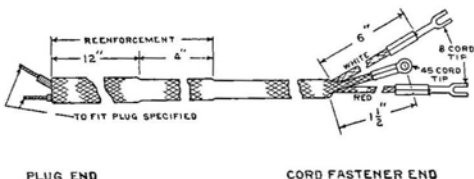

No. 493

Moistureproofed Tinsel Switchboard Cords

Code No.	No. of Conductors	For Western Electric Plug No.	Standard Length	List Price Each
447	3	109	6 ft. 3 in. and 8 ft.—unless otherwise specified 6 ft. 3 in. white cords furnished	\$1.35 6 ft. 3 in.
448	3	37, 78 or 110 as specified	4, 5, 6 ft. 3 in. and 8 ft.—unless otherwise specified 6 ft. 3 in. white cords arranged for No. 110 Plug will be furnished . . .	1.35 6 ft. 3 in.
493	2	32, 43, 47, 53 or 65 as specified	4 ft., 6 ft. 3 in. and 8 ft.—unless otherwise specified 6 ft. 3 in. white cords arranged for No. 47 Plug furnished . . . . .	.94 6 ft. 3 in.
511	1	116	4 ft. and 6 ft. 3 in.—unless otherwise specified 6 ft. 3 in. white cords furnished . .	.60 6 ft. 3 in.

## Operators' Telephone Cords

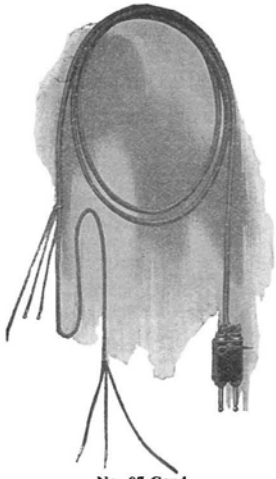

No. 87 Cord Attached to No. 103 or No. 137 Plug

These cords are designed for use in connection with switchboard operators' transmitter and receiver equipment.

Each conductor consists of 18 threads of a very high grade of tinsel twisted together in 3 strands of 6 threads each.

The conductor is then given a braiding of cotton and over this a braiding of silk.

The required number of conductors to make up any desired cord are then grouped together and all covered with a heavy braiding of green silk.

Cords having two or more conductors are furnished with conductor braiding having different standard color tracer threads, making it easy to distinguish any one conductor at either end of the cord.

In ordering be sure to specify length, observing stock lengths as listed. If cords are to be equipped with cord tips other than regularly furnished as listed, the tips desired should be clearly specified. If possible, when ordering cords for use with other than apparatus of Western Electric manufacture, send sample of cord now in use.

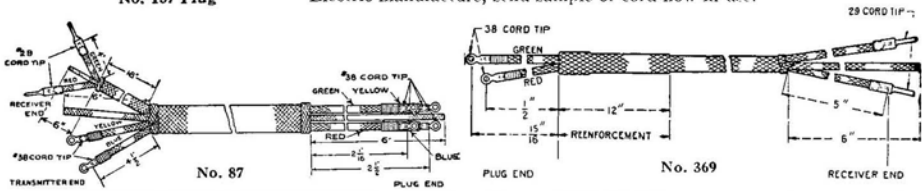

Code No.	Conductors	Use	Cord Tips			Length of Terminal Ends			Standard Length	Remarks	List Price Each
			Swbd. End	Rec. End	Trans. End	Swbd. End	Rec. End	Trans. End			
<b>Head Receiver Cords</b>											
11	3	Operator's head receiver on multiple magneto switchboards.	62	29	..	5"	5"	...	6 ft.		\$0.80
29	3	Operator's head receiver on multiple magneto switchboards with Nos. 85, 109 or 110 plugs	47	29	..	3 3/8, 3/4, 3/8"	5"	...	6 ft.	Cord arranged for No. 85 plug furnished unless otherwise specified.	.99
30	2	Head receivers on Wire Chief's and Chief Operator's desks with Nos. 47, 85 or 110 plugs	47	29	..	3/8, 3/8"	5"	...	4 1/2 and 6 ft.	Unless otherwise specified 6 ft. cords arranged for No. 85 plugs furnished.	6 ft. .645
254	2	No. 128W head receiver and No. 103 or No. 137 plugs on Nos. 9 and 105 switchboards using No. 232W transmitters.	38	29	..	2"	5"	...	4 1/2 and 6 ft.	Unless otherwise specified 4 1/2 ft. cords furnished.	4 1/2 ft. .545
369	2	Switchboard head receiver when attached to No. 136 plug on No. 1200 switchboards.	38	29	..	3/8, 1 1/8"	5"	...	4 1/2 and 6 ft. 3 ins.		4 1/2 ft. .54 6 ft. 3 in. .645
<b>Head Receiver and Chest Transmitter Cords</b>											
87	4	Operator's head receiver and chest transmitter with No. 103 or No. 137 plug.	38	29	38	2-2 1/4"	4"	4 1/2	4, 6 and 10 ft.	Unless otherwise specified 6 ft. cords are furnished.	6 ft. \$1.38
371	4	Double head receiver and chest transmitter. Receivers connected in multiple.	38	29	38	2-2 1/4"	4"	4 1/2	6 ft.		1.98
<b>Suspended or Swinging Transmitter Cord</b>											
437	1	Suspended type switchboard transmitters.	62	..	29	...	...	...	6 ft.		\$0.20

## CORDS

## Miscellaneous Central Office Cords

Cords that are used for miscellaneous purposes in a telephone central office must be of the highest quality obtainable. This is especially true of those cords which form a part of the testing circuits. Otherwise the results of the wire chief's testing would not be reliable.

That the Western Electric testing cords more than meet these requirements is attested to by the fact that there are many thousands in daily use in the largest local and long distance telephone exchanges in the country.

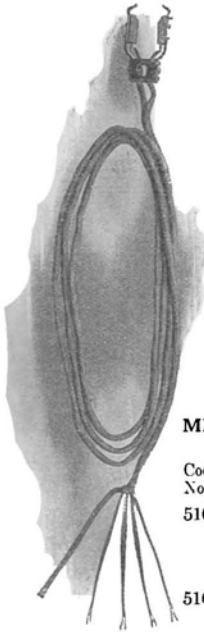

No. 555 Cord attached to No. 147 plug

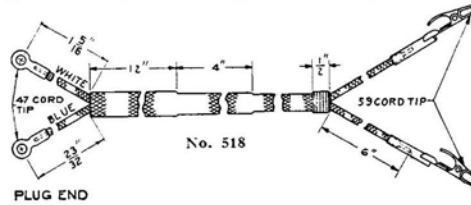

In ordering, specify length, observing standard stock lengths as listed.

## MISCELLANEOUS MOISTURE-PROOF TINSEL CENTRAL OFFICE CORDS

Code No.	Use	No. of Con-ductors	Outer Braid	Length of Terminal Ends	Cord Tips	Standard Lengths	List Price Each
510	Patching. Arranged for No. 116 plug on each end.	1	White Glazed Cotton	3/4 in. Both ends	None	2, 3 and 6 ft. Unless otherwise specified 2 ft. furnished. \$0.36 for 2 ft.	
516	Patching. Arranged for No. 47 plug on each end.	2	Red Glazed Cotton	3/8 and 1/8 in. Both ends	No. 38 on both ends	1, 2, 3, 4 and 6 ft. Unless otherwise specified 3 ft. furnished. \$0.54 for 3 ft.	
518	Service observing. Arranged for tip and ring connections to No. 110 plug.	2	Green Glazed Cotton	Plug end, 3/2 and 1 1/8 ins. Frame end, 6 ins.	Plug end, No. 47 Frame end, No. 59	10 ft.	\$1.40
520	Patching. Arranged for No. 141 type plug on each end.	2	White Glazed Cotton	1 1/2 ins. both ends.	Loop on both ends.	1, 2, 3, 4 and 6 ft. Unless otherwise specified 3 ft. furnished. \$0.54 for 3 ft.	
524	Service observing. Arranged for No. 144 plug on one end.	1	Green Glazed Cotton	Plug end, 5/8 in.	Plug end, loop Frame end, No. 59		.77
555	Main frame test cord with local test desk. Arranged for No. 147 plug on one end.	4	Green Glazed Cotton	Plug end, 2 1/2 and 3 ins. Cord fastener end, 6 ins.	Plug end, 2 No. 27 and 2 Bare Cord fastener end, No. 62	9 1/2 ft.	1.41
556	Main frame test cord with local test desk. Arranged for No. 47 plug at one end and connections 3 and 4 of the No. 132 plug at the other end.	2	Green Glazed Cotton	No. 47 plug end, 3/8 and 1 1/2 in. No. 132 plug end, 3 1/2 ins.	No. 47 plug end, No. 38 No. 132 plug end, P-107011	9 1/2 ft.	1.17
557	Main frame test cord with local test desk.	2	Green Glazed Cotton	6 in. both ends	Cord fastener end, No. 62 Frame end, No. 50.	9 1/2 ft.	1.40
558	Main frame test cord with local test desk. Arranged for No. 147 plug on one end and for No. 137 plug on the other end.	4	Green Glazed Cotton	No. 147 plug end, 2 1/2 and 3 ins. No. 137 plug end, 2 1/8 and 2 1/2 ins.	No. 147 plug end, No. 47 and 2 bare No. 137 plug end, No. 38	9 1/2 ft.	1.41

## CORDS

### Telephone Set Cords

Under this classification are listed cords for all types and styles of telephones, which will be found to suit every condition met with in actual service.

#### STANDARD TINSEL CORDS FOR REGULAR SERVICE

These cords are standard for all regular telephones, and include desk stand cords, receiver cords, and transmitter cords for all types of equipment.

The conductors are composed of a high grade of tinsel, each conductor consisting of 18 threads, 3 strands of 6 threads each being twisted together to form one conductor.

There are two general types of this cord, which differ only in the kind of insulating and braiding material used. They are commonly known as silk cords and worsted cords, as listed on the following pages.

The silk cord has the individual conductors insulated with a braiding of cotton and over this a braiding of silk, after which the required number of conductors are covered with another braiding of green silk.

The worsted cord has its individual conductors insulated with a serving of cotton, a braiding of cotton and a braiding of worsted. The required number of conductors are then covered with another braiding of red and blue worsted.

In the braiding of the individual conductors, colored tracer threads are used, making it easy to distinguish any one conductor at either end of the cord.

#### MOISTUREPROOFED CORDS

This line of cords was originally designed for railway telephone service where cords are subjected to more severe service conditions than are usually met with in ordinary telephone service. The line, however, has been improved and enlarged until we are now prepared to furnish moistureproofed cords for all classes of telephone service and to meet any specific requirement.

The most radical changes from the construction of the standard non-moistureproofed cord consists of treating the insulation of each conductor with an asphaltic, moistureproofing compound, and the use of an external braid of a very superior grade of Sea Island cotton. The three and four conductor cords have the conductors twisted together and the spaces between the conductors filled with 3 threads of 4 ply butchers' twine. On cords above 4 conductors no filler threads are needed.

As in the case of all Western Electric products, samples of these cords were subjected to the most thorough tests in our laboratory and also given long and severe tests under actual service conditions before they were offered for sale. In their development, cost was a minimum consideration, high insulation and long life being the determining factors.



**Construction of Moisture-proofed Tinsel Telephone Cords**

#### WATERPROOFED CORDS

These cords have the individual conductors insulated with a high grade of rubber before the braiding is applied. They are designed for use in connection with mine telephones, portable telephones, or other equipment located out of doors, underground, or wherever considerable moisture, dampness, or gaseous fumes are present.

#### INTER-PHONE CORDS

These cords are designed for use in connection with our line of inter-phone apparatus and cover a wide range of service.

The conductors are composed of a high grade of tinsel. Over each conductor is placed a braiding of cotton and over this a braiding of mercerized cotton. The required number of conductors are then covered with an outer braiding of black mercerized cotton.

**CORDS**  
**Receiver Cords**

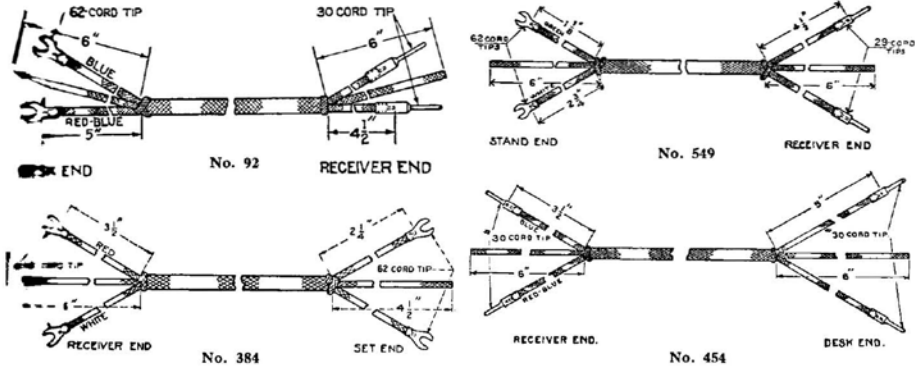

In ordering, specify length, observing stock lengths as listed,

No.	Type	Used with	Outer Braid	Cord Tips		Length of Terminal Ends		Standard Lengths	List Price Each
				Rec. End	Set End	Rec. End	Set End		

**WALL TELEPHONE RECEIVER CORDS**

17	Std. tinsel	Exposed binding post receivers on wall	Green silk	29	62	3 1/2 ins.	5 ins.	3 and 6 ft.	\$0.33 3 ft. .58 6 ft.
17	Std. tinsel	Exposed binding post receivers on wall	Red and blue worsted	30	62	4 1/2 ins.	5 ins.	2 1/2 ft.	.22
17	Std. tinsel	No. 146W receivers on wall	Red and blue worsted	30	22	3 ins.	5 ins.	2 1/2 ft.	.26
36	Inter- phone	Inter-phones and private line telephones	Green cotton	29	62	3 ins.	3 ins.	2 1/2 ft.	.39
34	Water- proofed	Nos. 1356 and 1357 type mine telephones and other sets exposed to moisture and gaseous fumes	Black and maroon mercerized cotton	62	62	3 1/2 ins.	2 1/4 ins.	10 1/2 ins.	.36
48	Moisture- proofed	No. 156W receiver on wall	Black and maroon mercerized cotton	29	62	3 1/2 ins.	1 1/4 and 2 3/4 ins.	2 1/4, 3 and 4 ft.	{ .335 2 1/4 ft. .37 3 ft. .44 4 ft.
44	Moisture- proofed	Nos. 1317W, AD, BC, BD, BL and 1305AC telephone	Black and maroon mercerized cotton	29	62	3 1/2 ins.	5 ins.	2 1/4 and 3 ft.	{ .335 2 1/4 ft. .37 3 ft.
43	Std. tinsel	Exposed binding post receivers on wall	Red and blue worsted	30	30	3 1/2 ins.	5 ins.	3 ft.	\$0.215
121	Std. tinsel	Concealed binding post receivers on wall	Red and blue worsted	62	62	4 1/2 ins.	5 ins.	2 1/2 ft.	.20
53	Std. tinsel	Wall inter-phones	Gray mercerized cotton	29	62	3 1/2 ins.	3 ins.	2 1/2 ft.	.39
54	Moisture- proofed	No. 186W or 189W receivers on wall	Black and maroon mercerized cotton	69	62	3 1/2 ins.	5 ins.	2 ft.	On request

**DESK STAND AND TELEPHONE ARM RECEIVER CORDS**

17	Std. tinsel	Nos. 1048BA, BB, BC, CA, CB and CC telephone arms	Green silk	29	62	4 1/2 ins.	2 ins.	2 1/2 ft.	\$0.33
34	Std. tinsel	Nos. 1040G and H telephone arms	Green silk	29	62	4 1/2 ins.	3 1/4 ins.	2 1/2 ft.	
35	Std. tinsel	No. 146W receivers on desk stands	Green silk	29	62	3 ins.	2 3/4 and 1 1/2 ins.	3 ft.	
36	Std. tinsel	No. 147W receivers on desk stands	Green silk	29	62	3 ins.	1 and 2 3/4 ins.	6 ft.	.92
17	Std. tinsel	Nos. 1020W, 1120BE and 1320BF desk stands	Green silk	29	62	3 1/2 ins.	2 ins.	2 1/2 ft.	.41
17	Std. tinsel	Nos. 1040BC, DC, FC and JC telephone arms	Green silk	29	62	4 1/2 ins.	2 3/4 and 1 1/2 ins.	2 1/2 ft.	.285
4	Moisture- proofed	No. 146W receiver on desk stands and telephone arms	Black and maroon mercerized cotton	29	62	3 1/2 ins.	1 1/4 and 2 3/4 ins.	2 1/4, 3 and 4 ft.	{ .335 2 1/4 ft. .37 3 ft. .44 4 ft.
42	Std. tinsel	Nos. 1020U, 1120CN and 1320CN desk stands	Green silk	62	62	3 1/2 ins.	ins.	3 ft.	.33
53	Std. tinsel	Inter- phone desk stands	Gray mercerized cotton	29	62	3 1/2 ins.	3 ins.	2 1/2 ft.	.39
54	Water- proofed	Desk stands and telephone arms in place of No. 549 when a waterproofed cord is desired	Black mercerized cotton	30	62	4 1/2 ins.	1 1/4 and 2 3/4 ins.	2 1/2 ft.	.47
54	Std. tinsel	Nos. 1020AL, BC, MC, PC and SC desk stands and Nos. 1048AA, AB, AC, EA, EB and EC telephone arms	Green silk	29	62	4 1/2 ins.	1 1/4 and 2 3/4 ins.	2 1/2 ft.	.29
54	Moisture- proofed	No. 186W or 189W receiver on desk stands and telephone arms	Black and maroon mercerized cotton	69	62	3 1/2 ins.	1 1/4 and 2 3/4 ins.	2 1/2 ft.	On request

CORDS

Desk Stand and Telephone Arm Cords

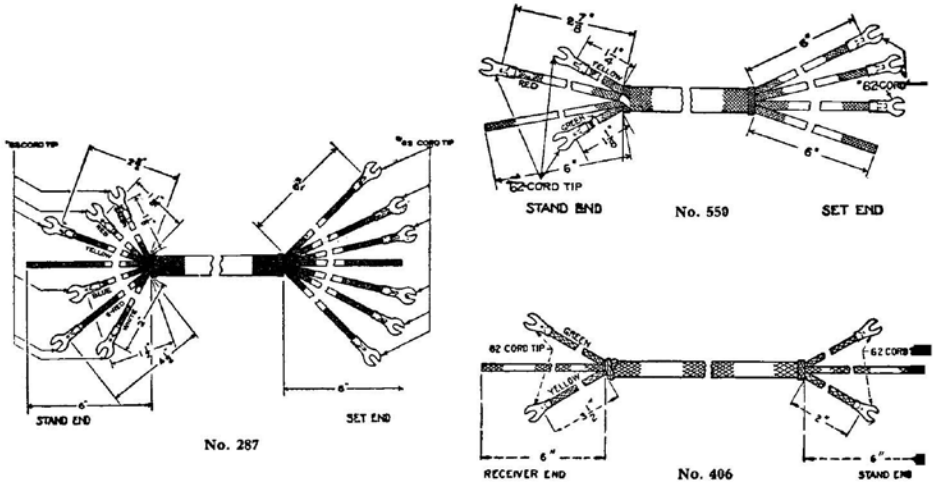

In ordering specify length, observing stock lengths as listed.

Code No.	Type	Used with	No. of Conductors	Outer Braid	Cord Tips		Length of Terminal Ends Inches		Standard Lengths Feet	List Price Each
					Stand End	Box End	Stand End	Box End		
231	Std. tinsel	Nos. 1020C, F, AD; 1120T, BE and 1320CN desk stands.	4	Green silk	62	62	2-1½, 4½, 2¾	6	6	On request
287	Std. tinsel	Nos. 1020H, AN, CH and CN desk stands and Nos. 1048BA, BB and BC telephone arms.	6	Green silk	62	62	2-1½, 2¾, 1½, 4½ and 2	6	5½ and 10	{ \$1.44 5½ ft. \$2.34 10 ft. On request
300	Std. tinsel	No. 1020R desk stand.	5	Green silk	62	62	1, 3, 4, 1½, 3½	6	6	On request
313	Std. tinsel	Nos. 1040BC, DC, FC and JC telephone arms.	3	Green silk	62	62	2, 1, 2,	6	5½	.74
355	Std. tinsel	Nos. 1020T, W, and 1120CN desk stands and Nos. 1048CA, CB and CC telephone arms.	5	Green silk	62	62	2-2½, 1½, 1¾, 4¾	6	5½	1.41
365	Std. tinsel	No. 1020U desk stand.	4	Green silk	62	62	1½, 2-1½, 2¾	3	6	.95
406	Std. tinsel	Nos. 1020AG, AH, AK, AM; 1120AG, AH; 1320P and BF desk stands, and Nos. 1048EA, EB and EC telephone arms.	2	Green silk	62	62	2	3½	6	.54
409	{ Moisture-proofed	Nos. 1020AA, AB and DSP desk stands and Nos. 1020C, D; 1048DA, DB, DC and DD telephone arms.	3	Black and maroon mercerized cotton	62	62	2½, 1¼, 1¼	6	6 and 8	{ .88 6 ft. 1.13 8 ft.
416	{ Moisture-proofed	Train dispatching desk stands and telephone arms using non-insulated transmitters.	4	Black and maroon mercerized cotton	62	62	2-1½, 4, 3	6	6 and 8	{ .99 6 ft. 1.24 8 ft.
435	Std. tinsel	No. 1020BH desk stand.	3	Gray mercerized cotton	62	62	1½, 1¼, 2½	6	6	1.00
534	Std. tinsel	Nos. 1020AW, BG, BJ; 1220BG and 1320BG desk stands.	4	Gray mercerized cotton	62	62	1¼, 2-2, 4	6	6	1.00
541	{ Water-proofed	Desk stands and telephone arms in place of No. 550 when a water-proofed cord is desired.	3	Black mercerized cotton	62	62	1½, 1¼, 2½	6	5½, 8, 10 and 12	1.42 5½ ft.
543	{ Water-proofed	Desk stands in place of No. 551 when a water-proofed cord is desired.	4	Black mercerized cotton	62	62	2, 2-1½, 1½	6	5½	1.80
550	Std. tinsel	Nos. 1020AL, AP, BC, MC, PC, and SC desk stands and Nos. 1048AA, AB and AC telephone arms.	3	Green silk	62	62	1½, 1¼, 2½	6	5½, 8, 10 and 12	.74 5½ ft.
551	Std. tinsel	Nos. 1020CE and CF desk stands.	4	Green silk	62	62	2, 2-1½, 1½	6	5½	.95
563	Std. tinsel	No. 1020AT desk stand.	11	Gray mercerized cotton	62	62	9-5, 2-7	4	6	On request
564	Std. tinsel	No. 1020AS desk stand.	7	Gray mercerized cotton	62	62	5-5, 2-7	3	6	On request

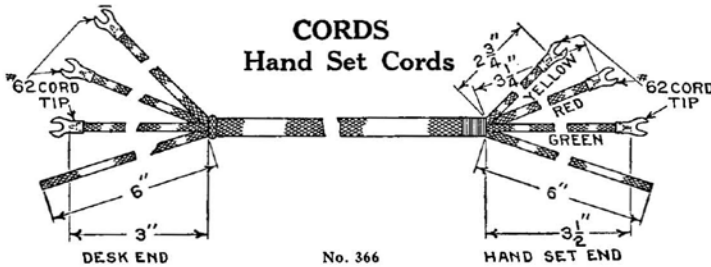

In ordering specify length, observing stock lengths as listed,

Code No.	Type	Use	No. of Conductors	Outer Braid	Hand Set End	Box End	Length of Terminal Ends (Inches)	Standard Length	List Price Each
348	Waterproofed	No. 1001A hand sets for linemen's testing.	2	Blk. mercerized cotton	62	50	1 1/2, 7 1/4	1 ft. 3 ins. 3, 4 & 6 ft.	\$0.97 3 ft.
422	Waterproofed	No. 1001F hand set when used with No. 1278 type telephone.	3	Blk. mercerized cotton	54	54	3 1/2, 3 1/4, 2 3/4	3 ins. 6 ft.	1.17
366	Waterproofed	No. 1001C hand set.	3	Blk. mercerized cotton	62	62	3 1/2, 3 1/4, 2 3/4	3 ins. 6 ft.	.83
403	Std. tinsel	No. 1002C hand set in inter-telephone systems.	5	Green silk	56	62	7, 2 1/2, 2, 1 1/2, 6 1/2	3 1/4 ins. 5 1/2 ft.	1.71
414	Std. tinsel	No. 1002AC hand set.	1	Green silk	No. 56 on one end—loop on the other	62	....	4 1/4 ins.	.09 1/2
318	Std. tinsel	No. 1002AC hand set.	3	Green silk	2-56 1 loop	62	1 1/2, 7, 7 1/4	6 ins. 4 1/2 ft.	.65
415	Std. tinsel	No. 1002AC hand set.	1	Green silk	No. 56 on both ends	62	....	9 1/2 ins.	.09 1/2
477	Inter-telephone	No. 1003D and K hand sets.	2	Blk. cotton	56	1-56	1-56	2 3/4 ins. 3 ft.	.60
480	Inter-telephone	No. 1003J hand set.	3	Blk. cotton	56	2-56	2-3, 1 1/2	2 1/4 ins. 3 ft.	.84

**Transmitter Cords (SINGLE CONDUCTOR)**

In ordering specify length, observing stock lengths as listed:

**WALL TELEPHONE TRANSMITTER CORDS**

Code No.	Type	Use and Description	Outer Braid	Trans. End	Set End	Standard Length	List Price Each
329	Std. tinsel	Nos. 1130, 1293, 1294, 1317, 1322, 1351, 1352, 1353, 1355 and 1352 type sets when using Nos. 269W, 282W, 284W, 291W, 293W, 298W, 301W and 305W transmitters.	Green silk	56	62	9 1/4 ins.	\$0.12 1/2
547	Std. tinsel	Nos. 1240, 1293, 1305, 1317, 1324, 1325, 1333 and 1357 type sets when using Nos. 303W, 311W, 317W, 325W, 329W and 350W transmitters.	Green cotton	56	62	5 1/2, 8 & 9 1/4 ins.	.08 9 1/4 ins. or less
548	Std. tinsel	Nos. 1240, 1293, 1294, 1305, 1317, 1333 and 1357 type sets when using Nos. 250W, 311W, 317W, 329W and 350W transmitters.	Green cotton	55	62	5 1/2, 8 & 9 1/4 ins.	.08 9 1/4 ins. or less

**DESK STAND TRANSMITTER CORDS**

329	Std. tinsel	Desk stands, Western Electric No. 1020 type.	Green silk	56	62	9 3/8 ins.	.12 1/2
547	Std. tinsel	Insulated type transmitters on desk stands, Western Electric No. 1020PC, AL, CE and CF.	Green cotton	56	62	5 1/2, 8 & 9 1/4 ins.	.08 9 1/4 ins. or less
548	Std. tinsel	Insulated type transmitters on desk stands, Western Electric No. 1020PC, AL, CE and CF.	Green cotton	55	62	5 1/2, 8 & 9 1/4 ins.	.08 9 1/4 ins. or less
423	Moisture-proofed	Desk stands using non-insulated transmitters, Western Electric No. 1020.	Maroon mercerized cotton	61	62	9 1/2 & 12 ins.	.08 9 1/2 ins.
426	Moisture-proofed	Desk stands using insulated type transmitters, Western Electric No. 1020.	Black mercerized cotton	56	62	9 1/2 & 12 ins.	.09 9 1/2 ins.
427	Moisture-proofed	Differs from No. 426 only in color of tracer.	Black mercerized cotton	56	62	9 1/2 & 12 ins.	.09 9 1/2 ins.
463	Moisture-proofed	Desk stands in humid climate, Western Electric No. 1020, similar to No. 329.	Maroon mercerized cotton	56	62	9 1/2 ins.	.08

**HAND SET TRANSMITTER CORDS**

243	Std. tinsel	Hand set, Western Electric No. 1001A.	Green silk	62	62	5 ins.	.07
336	Std. tinsel	Hand set, Western Electric No. 1002A.	Green silk	56	Loop	4 1/2 & 14 ins.	.09 1/2 4 1/2 ins.
390	Std. tinsel	Telephone arms, Western Electric No. 1040.	Green silk	61	62	5 1/2, 9 1/2 & 14 ins.	.08 9 1/2 ins. or less
385	Water-proofed	Mine telephones or sets exposed to dampness or gaseous fumes, Western Electric No. 1336F and H.	Blk. cotton	56	62	7 ins.	.09
437	Std. tinsel	Transmitter arms or suspended transmitters.	Green silk	29	62	6 ft.	.20

## CORDS

### Miscellaneous Cords

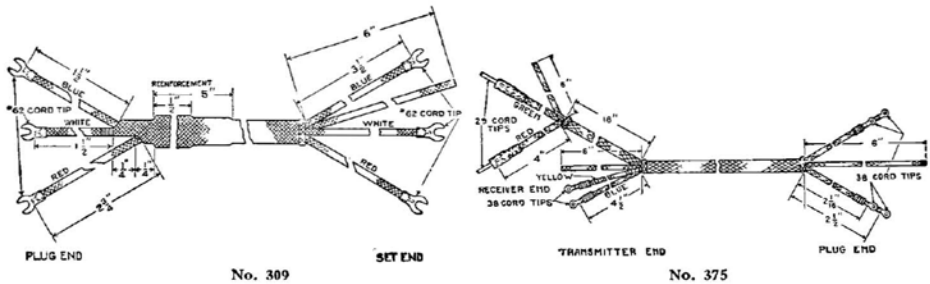

In ordering, specify length, observing stock lengths as listed.

Code No.	Used With	No. of Conductors	Conductor Material	Insulation	Outer Braid	Cord Tips	Std. Length	List Price Each
267	No. 1314 type telephone set and rail clamp.	1	Tinsel	Cotton and Rubber	Black Glazed Cotton	Set End—No. 62 Clamp End—No. 29	10 ft.	\$0.235
309	No. 1280 telephone set and No. 126 plug.	3	Tinsel	Cotton and Rubber	Black mercerized cotton	No. 62 both ends	15 ft.	1.26
363	Nos. 147W and 153W receivers in train dispatching service.	4	Tinsel	Cotton and silk	Green silk	Rec. End—No. 29 Plug and Trans. End—No. 38	6 ft.	1.37
371	No. 164W receiver in train dispatching service.	4	Tinsel	Silk	Green silk	Rec. End—No. 29 Plug and Trans. Ends—No. 38	6 ft.	1.98
375	No. 148W receiver in train dispatching service.	4	Tinsel	Moistureproofed worsted	Black and maroon cotton	Rec. End—No. 29 Plug and Trans. Ends—No. 38	6 ft.	1.48
509	Nos. 1330F and 1331F portable telephone sets and No. 146 plug.	2	Tinsel	Cotton and rubber	Black glazed cotton	Plug End—No. 62 Set End—No. 22	6 ft.	.63
513	Test boards in train dispatching service with Western Electric No. 116 plug.	1	Tinsel	Moistureproofed cotton and silk	*Glazed cotton	One End—No. 62 Other End—None	2 ft.	.40
519	Test boards in train dispatching service with Western Electric No. 116 plug.	1	Tinsel	Moistureproofed cotton and silk	*Glazed cotton	One End—No. 62 Other End—None	2 ft.	.35
523	No. 1017 type lineman's test sets.	2	Tinsel	Cotton and rubber	Black mercerized cotton	Set End—No. 30 Rec. End—No. 30	2½ ft.	.60
540	For connecting dry batteries. (See "Battery Connectors" page 20.)	1	Stranded copper	Moistureproofed cotton	Brown cotton	5/8 inch bare both ends	5 ins.	1.20 per C
565	No. 189W receiver in train dispatching service.	4	Tinsel	Moistureproofed worsted	Black and maroon cotton	Rec. End—No. 30 Plug and Trans. Ends—No. 38	6 ft.	On request
566	No. 190W receiver in train dispatching service.	4	Tinsel	Cotton and silk	Green silk	Rec. End—No. 30 Plug and Trans. Ends—No. 38	6 ft.	On request
567	No. 191W receiver in train dispatching service.	4	Tinsel	Silk	Green silk	Rec. End—No. 30 Plug and Trans. Ends—No. 38	6 ft.	On request

\*Furnished in red, white, black or green, as specified in order.

Telephone Apparatus and Supplies

**CORD FASTENERS**



No. 9

Code No. 9 Used on cord shelves with all types of switchboard cords. . . . . List Price Each \$0.054

**CORD HOOKS**

The two types of cord hooks shown will meet all requirements. The No. 3 is the screw hook type, and can be mounted in any desired location. The No. 7 is designed for placing on the rear edge of cord shelves, and consists of a flat strip of brass 1/16 inch thick by 3/4 inch wide, the hooks being punched out at various spacings as listed in the following table. Hooks of this type are strong and efficient, and present a neat appearance and occupy a minimum amount of space.



No. 3



No. 7A, 3 per strip

Code No.	Spacing of Hooks Inches	Maximum Number of Hooks per Strip	List Price Each
3		Single	Per gross \$0.70
7A	3/32	*14	.45
7B	1/2	*24	.40
7C	3/4	*16	.48
7D	1 1/2	*29	.45
7E	5/8	*19	.43
7F	7/16	*27	.48
7G	1 1/4	*22	.50
7H	1 1/8	*10	.45
7J	3/8	*32	.36

\*Furnished with any number of hooks per strip from 2 up to the maximum indicated. The number of hooks per strip desired must be specified in the order.

To determine overall length multiply the number of hooks desired by the spacing.



No. 106



No. 109



No. 111

**CORD PULLEYS**

These have brass wheels except the No. 109, which has a rubber wheel. They are for use with our standard switchboard or telephone cords as the case may require.

Code No.	Width of Wheel Inches	Width Inches	List Price Each
106	3/2	1 1/16	\$0.32
109	1 1/2	1 1/16	.25
111	1 1/4	3/8	.38

**CORD WEIGHTS**



No. 103



No. 108



No. 116

Code No.	Style	Used with	List Price Each
103	Brass, 14 oz.	Suspended transmitter and No. 7 type transmitter arm. . . . .	\$1.00
108	Lead, 28 oz.	Switchboards when cord pulley is used. . . . .	.90
116	Steel clad lead (9 1/2 oz.)	Switchboards. . . . .	.38

Telephone Apparatus and Supplies



## COUNTER

(No. 10A Message Register)

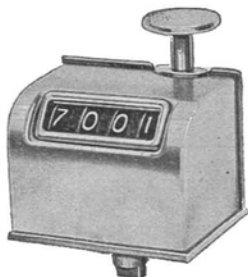

No. 10A

For counting the number of telephone calls handled at one switchboard position or by one operator, as the case may be. Arranged for use with socket No. 12005 permanently mounted flush with the top of the switchboard keyshelf, from which the counter can be removed at will, or with the portable base No. 12004. Designed to facilitate the taking of "peg count." Counts to 9,999 and then repeats.

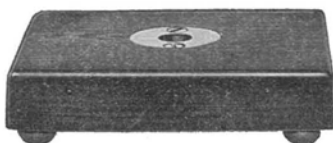

No. 12004

Code No.	Description	List Price Each
10A	Counter only.....	\$4.30
12004	Portable base.....	.80
12005	Flush socket for permanent mounting.....	.20

## CUT-IN STATIONS



No. 12005

Used at an intermediate station in a toll line to cut off the line in either direction. It is used in connection with a separate telephone which is wired to the cord and plug. When the plug is inserted in either the left or right hand jacks the telephone is connected to that portion of the line, and the opposite portion cut off and connected to the bell of the "cut-in station."

When the plug is removed the line is connected through and the bell bridged across the line.

By inserting the plug in the middle jack the telephone is bridged across the line.

Regularly furnished in oak.



No. 319 Type

## For Magneto Bridging Service

Code No.	Description	List Price Each
319E	1000 ohm unbiased ringer.....	\$8.80
319F	1600 ohm unbiased ringer.....	9.80
319G	2500 ohm unbiased ringer.....	9.80

## DESIGNATION STRIPS Wooden Type With Metal Face



These consist of a wooden mounting strip with a black finished No. 8 type designation or retaining strip attached to its face, and are for use in designating outgoing trunk jacks, etc.

Code No.		Width of Face, Ins.	Length, Ins.		Jack Mountings Used with	List Price Each
			Overall	Face		
No. 1C						
1C		$\frac{7}{16}$	9 $\frac{1}{8}$	9 $\frac{3}{16}$	Nos. 1, 2, 3, 21, 22, 34, 36, 46 47, 62, 63, 75, 77, 84, 85 117, 118, 119, 120, 127	} \$0.40
1D		$\frac{1}{4}$				
*1G		$\frac{1}{2}$				
*1H		$\frac{3}{8}$				
6F		$\frac{3}{8}$				
*6J		$\frac{7}{16}$	8 $\frac{3}{8}$	7 $\frac{3}{8}$	Nos. 18, 19, 20, 83, 102, 113	} .40
*6K		$\frac{1}{2}$				
10D		$\frac{1}{16}$	11 $\frac{1}{8}$	10 $\frac{1}{2}$	Nos. 4, 5, 6, 7, 8, 35, 37, 45, 89, 115 Nos. 108, 109, 110, 112	} .40
51A	1	$\frac{1}{16}$	11 $\frac{3}{16}$	11 $\frac{3}{16}$		
53A		$\frac{7}{16}$	6 $\frac{3}{8}$	5 $\frac{3}{8}$	Used on No. 105B Magneto Switchboard	2.30

\*Has a  $\frac{1}{16}$  inch holly strip mounted on top. The width of face as given above includes the holly strip.

## Wooden Type With Rubber Face



These consist of a wooden mounting strip with a hard rubber face which is milled and drilled for 20 number plates.

Code No.		Width of Face, Ins.	Length, Ins.		Number Plates Arranged for	Jack Mountings Used with	List Price Each
			Overall	Face			
No. 14A							
2D		$\frac{1}{4}$	9 $\frac{1}{8}$	9 $\frac{3}{8}$	No. 17	} Nos. 1, 2, 3, 21, 22, 34, 36, 46, 47, 62, 63, 75, 77, 84, 85, 117, 118, 119, 120, 127	\$1.20
14A		$\frac{3}{8}$	8 $\frac{3}{8}$	7 $\frac{3}{8}$	No. 6, 30 or 60		
50A		$\frac{1}{16}$	11 $\frac{1}{16}$	11 $\frac{1}{16}$	No. 4, 31, 32 or 59	Nos. 18, 19, 20, 83, 102, 113	1.70
50B		Same as 50A, except equipped with a $\frac{1}{16}$ in. holly strip				Nos. 108, 109, 110, 112	1.80
						Nos. 108, 109, 110, 112	1.80

## Wooden Type With Celluloid Face



These consist of wooden mounting strips with transparent celluloid face strips which are intended to cover a strip of printed figures.

Code No.		Width of Face, Ins.	Length, Ins.		Jack Mountings Used with	List Price Each
			Overall	Face		
No. 7A						
7A		$\frac{7}{16}$	9 $\frac{1}{8}$	9 $\frac{3}{8}$	Nos. 1, 2, 3, 21, 22, 34, 36, 46, 47, 62, 63, 75, 77, 84, 85, 117, 118, 119, 120, 127	} \$0.36
7B		$\frac{1}{4}$				
*7C		$\frac{1}{2}$				
13A		$\frac{3}{8}$				
*13B		$\frac{1}{16}$				
*13D		$\frac{1}{2}$	8 $\frac{3}{8}$	7 $\frac{3}{8}$	Nos. 18, 19, 20, 83, 102, 113	} .40
24A		$\frac{1}{16}$				
48A		$\frac{1}{16}$	11 $\frac{1}{8}$	10 $\frac{1}{2}$	Nos. 6, 7, 8, 35, 37, 45, 89	.40
*48C		$\frac{1}{2}$	11 $\frac{3}{8}$	11 $\frac{3}{8}$	Nos. 108, 109, 110, 112	.40
						.50

\*Has a  $\frac{1}{16}$  inch holly strip mounted on top. The width of the face as given above includes the holly.

## Metal Type

These consist of a black finish metal retaining strip. The Nos. 8G, H and K also have a transparent celluloid strip for protecting a strip of printed figures. Mounting screws are furnished.

Code No.		Width, Ins.	Length	List Price Each
No. 8 Type				
8G		$\frac{7}{16}$	As specified	\$0.40 per ft.
8H		$\frac{3}{8}$	As specified	.34 per ft.
8K		$\frac{5}{8}$	6 $\frac{1}{8}$ in. unless otherwise specified	.22
43B		$\frac{3}{8}$	1 $\frac{1}{2}$ ins.	.135
43C		$\frac{3}{4}$	1 $\frac{1}{4}$ ins.	.135
43D		$\frac{3}{4}$	1 $\frac{1}{4}$ ins.	.11

## DESK STANDS



No. 1020AL



No. 1020AB



Showing Method of Removing Working Parts

Western Electric desk stands have been carefully designed to reduce maintenance expense to a minimum. They are graceful in appearance and light enough to handle with ease, yet sufficiently rugged to withstand hard knocks and continuous service. They are made of carefully inspected materials and every stand is given a rigid test before leaving the factory.

The contact springs and cord terminals are mounted on a steel terminal plate which also supports the receiver hook and transmitter lug holder. This terminal plate is concealed in the upright or stem of the stand and can be removed as a unit for inspection without disturbing the adjustment of the contact springs by removing one screw in the base of the stand. The cords enter the stand through a bushed hole in the top of the base, and the bottom of the base is covered with a felt pad to prevent scratching highly polished surfaces.

All the stands listed below have black finish.

The transmitters and receivers furnished are standard Western Electric quality.

## Regular Bridging—Magneto or Central Battery Service

Code No.	Cords	Trans. No.	Receiver No.	Description	List Price Each
1020AL	1 5½ ft. No. 550	329W	143AW	Desk stand for regular magneto or central battery telephone service.	\$11.70
	1 2½ ft. No. 549				
	1 9⅞ in. No. 547				
	1 9⅞ in. No. 548				

## Series Talking Circuit—Central Battery Service

Code No.	Cords	Trans. No.	Receiver No.	Description	List Price Each
1020AH	1 6 ft. No. 406	291W	171W	Desk stand for use in series talking circuit. Central battery systems.	\$11.70
	1 2½ ft. No. 389				
	1 9⅞ in. No. 329				
	1 9½ in. No. 330				

## Series Ringing Circuit—Series Magneto Service

Code No.	Cords	Trans. No.	Receiver No.	Description	List Price Each
1320CN	1 6 ft. No. 231	329W	143AW	Desk stand for use in series magneto service.	\$12.40
	1 2½ ft. No. 412				
	1 9⅞ in. No. 547				
	1 9⅞ in. No. 548				

## Railway Telephone Service

Code No.	Cords	Trans. No.	Receiver No.	Description	List Price Each
1020U	1 6 ft. No. 365	329W	144AW	Desk stand for use with railway composite telephones.	\$13.90
	1 2½ ft. No. 412				
	2 9⅞ in. No. 547				
1020AB	1 5½ ft. No. 409	280W	156W	Desk stand with head band type receiver for use at way stations on railway train dispatching circuits.	16.40
	1 2½ ft. No. 408				
	1 9⅞ in. No. 426				
	1 9⅞ in. No. 427				
1020DSP	1 5½ ft. No. 409	280W	148W	Desk stand having an insulated transmitter and head receiver. Used in railway train dispatching circuits in connection with a No. 295DSP desk set box.	16.00
	1 2½ ft. No. 408				
	1 9⅞ in. No. 426				
	1 9⅞ in. No. 427				

**DESK STANDS**  
**Repair Parts for No. 1020AL Stands**

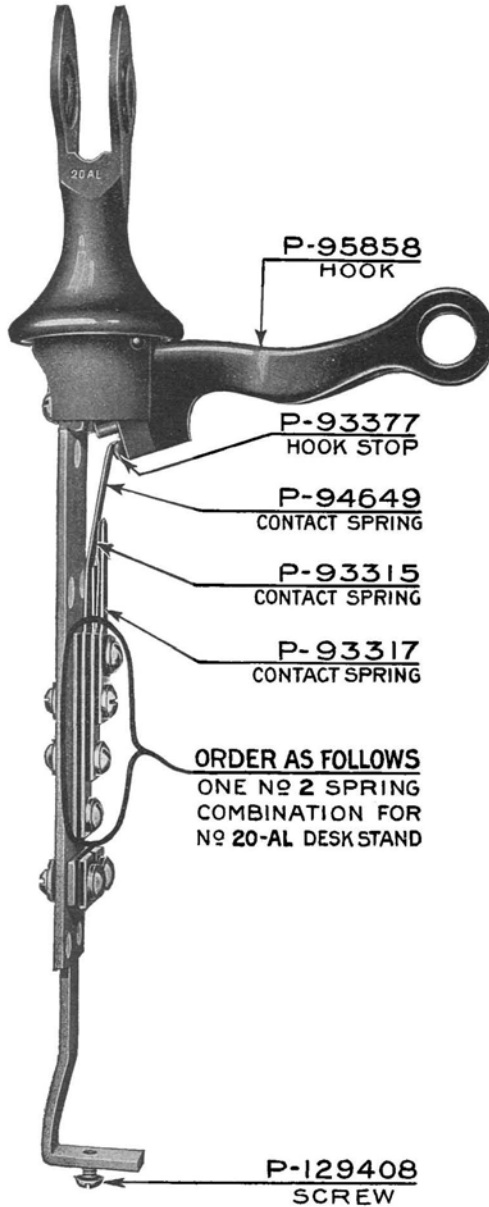

**No. 20-AL DESK STAND**

## DESK SET BOXES Central Battery

For Use With Desk Stands, Telephone Arms, Hand Sets, Etc.

### No. 334 Type



No. 334 Type

These consist of a pressed sheet metal box, copper plated and given two coats of black enamel and equipped with apparatus as listed below.

Simplicity in design and accessibility of apparatus are noteworthy features of this type of central battery desk set box.

Every part of the interior is readily accessible when the door is opened for test or inspection.

Spacing of apparatus is ample without sacrificing compactness.

All binding posts are of the screw type and permanent connections are soldered.

View of ringer is unobstructed so that action can be watched while adjusting.

All wiring is in cable form, rendering wires less liable to damage and producing a neater looking and more accessible interior.

Wires are of differently colored insulation, making it easy to trace the circuit.

The induction coil and condenser are mounted so that they may be removed as a unit.

Ringer mounting bracket is arranged for either alternating current or harmonic ringers.

A wiring diagram with clear, concise instructions is furnished in every No. 334 type desk set box.

The various boxes of this type will meet every requirement of central battery service for single, two-party selective or four-party semi-selective alternating ringing and four and eight-party selective and sixteen-party semi-selective harmonic ringing systems. Besides those of the induction coil type, there is the series type, which has no induction coil. Induction coil apparatus, however, is recommended where the highest grade of transmission is required.

**Induction Coil Boxes:** Boxes of this type contain the induction coil, condenser, ringer and the necessary terminals.

**Series Boxes:** Boxes of this type differ from the Induction Coil type in that they do not contain an induction coil, this piece of apparatus not being used in a series central battery circuit.

### Ringers Operated by Alternating Current

#### Individual 2-party Selective or 4-party Semi-selective Signaling

Code No.	Ringer	Type	Used with	List Price Each
334A	1000 ohms	Induction coil	No. 1020AL desk stands, Nos. 1048AA, AB and AC telephone arms and No. 1002AC hand sets. Forms part of the No. 6032W (induction coil type) desk telephone.....	\$8.10
334N	1000 ohms	Series	No. 1020AH desk stands. Forms part of No. 6032U (series type) desk telephone.....	5.90

### Ringers Operated by Harmonic Current

#### 4 and 8 Party Selective or 16 Party Semi-selective Service

334E	33 $\frac{1}{3}$ cycles	Induction coil	No. 1020AL desk stands, Nos. 1048AA, AB and AC telephone arms, and No. 1002AC hand set. Form part of the Nos. 6032K, L, M and N desk telephones respectively.	\$10.70
334F	50 cycles			10.70
334G	66 $\frac{2}{3}$ cycles			10.70
334H	16 $\frac{2}{3}$ cycles			10.70

**DESK SET BOXES**

**Central Battery**

**No. 295 Type**



**No. 295 Type**

Oak boxes equipped with the following apparatus. Intended for railway train dispatching service.

Code No.	Ringer	Retardation Coil No.	Condenser No.	Induction Coil No.	Service	List Price Each
295AJ	....	....	21AA	29	As a part of the dispatcher's talking outfit.	\$5.90
295AK	....	51A	21AA	29	With No. 1020AB desk stand in way station telephone equipment.	7.20

**No. 358 Type**



**No. 358 Type**

Semi-flush black finished metal desk set boxes. The metal wall box is detachable and can be installed during construction of building, leaving the apparatus and face plate to be installed later.

The No. 31A apparatus blank is used as a cover for the outlet box when it is desired to install outlet boxes for future use, or when a set is removed from service. These apparatus blanks consist of a black finished metal cover with an iron molding.

Code No.	Ringer	Condenser No.	Induction Coil No.	Service	List Price Each
358A	16BG	21D	20	Bridging, single, 2 party selective or 4 party semi-selective signaling. Used with No. 1020AL desk stand, Nos. 1048AA, AB and AC telephone arms and No. 1002AC hand sets.	\$12.40

**No. 31A Apparatus Blank**

Price on request.

**No. 311A Desk Set Box**

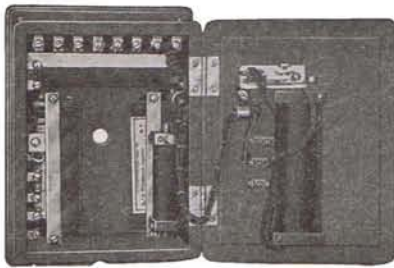

**No. 311A**

Telephone Apparatus and Supplies

Oak box used with a No. 1020U desk stand in railway composite desk telephone, No. 6023A.

For same class of service as the No. 1312A wall telephone.

Equipped with:

- One No. 21D condenser.
- One No. 21H condenser.
- One No. 21U condenser.
- One No. 12G retardation coil.
- One No. 5 induction coil with interrupter.
- One No. 1C howler.
- List Price each, \$23.50.

## DESK SET BOXES (Magneto)

For Use with Desk Stands, Telephone Arms, etc., on Magneto or Local Battery Lines

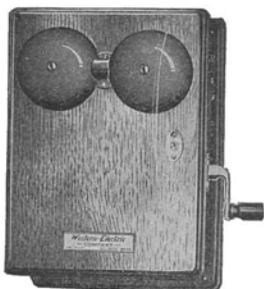

Nos. 300 and 315 Type Desk Set Boxes

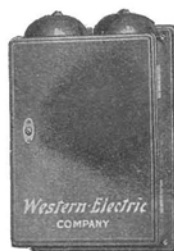

No. 295 Type Desk Set Box

### Nos. 300, 315 and 354 Types

Oak boxes equipped with induction coil, and with ringer, generator and condenser as indicated below.

#### RINGERS OPERATED BY ALTERNATING CURRENT

##### Code Ringing

Code No.	Ringer Resistance Ohms	Generator	Con-denser	Service	Used with	List Price Each	
315H	1000	22 type (3 bar A.C.)		Light loaded lines	No. 1020AL desk stand and Nos. 1020AC, 1048AA, AB and AC telephone arms.	\$11.30	
300K	2500	48 type (5 bar A.C.)	*	Heavy loaded lines		17.20	
300N	2500	48 type (5 bar A.C.)	1 Mf.	Heavy loaded lines		18.60	
300L	1600	48 type (5 bar A.C.)	*	Medium loaded lines		17.20	
300M	1600	48 type (5 bar A.C.)	1 Mf.	Medium loaded lines		18.60	
300AA	2500	50 type (3 bar A.C.)	*	Heavy loaded lines		On request	
300AB	1600	50 type (3 bar A.C.)	*	Medium loaded lines		On request	
315G	50	22 type (3 bar A.C.)		Series Service		No. 1320CN desk stand	11.20
†354H	1000	22 type (3 bar A.C.)		Grounded block wire circuits in railway block towers		No. 1020AL desk stand	13.60

#### RINGERS OPERATED BY PULSATING CURRENT

##### Four-party Selective Signaling

315J	2500 (Biased)	22 type (2 bar A.C.)		Any one of four parties	No. 1020AL desk stand and Nos. 1020AC, 1048AA, AB and AC telephone arms	\$12.30
------	---------------	----------------------	--	-------------------------	---	---------

#### RINGERS OPERATED BY HARMONIC CURRENT

##### Four or Eight-party Selective or Sixteen-party Semi-selective Signaling

Code No.	Ringer	Frequency Cycles	Generator	Con-denser	Service	Used With	List Price Each
354A	41 type	33 $\frac{1}{3}$	22 type (3 bar †)	1 Mf.	Harmonic selective signaling lines only	No. 1020AL desk stand and Nos. 1020AC, 1048AA, AB and AC telephone arms	\$15.00
354E	41 type	50	22 type (3 bar †)	1 Mf.			15.00
354F	41 type	66 $\frac{2}{3}$	22 type (3 bar †)	1 Mf.			15.00
354G	41 type	16 $\frac{2}{3}$	22 type (3 bar †)	1 Mf.			15.00

\*Arranged for a No. 21 type condenser, but not equipped unless so ordered.

† Includes a No. 12G retardation coil.

‡ Delivers alternating current, but contact springs are arranged so that approximately one impulse of current out of four is sent over the line.

### No. 295 Type

Oak boxes not equipped with generators. Used principally for furnishing extension service to main telephones.

Code No.	Ringer Resistance Ohms	Condenser	Service	List Price Each
295S	1000	.....	Light loaded lines. Code ringing	\$6.10
295Y	2500 (biased)	.....	4-party selective signaling	6.80

## DISTRIBUTING FRAMES

These distributing frames have been designed to meet the requirements of small central offices where simple and compact protective equipment is desired.

They are constructed of steel and given a coat of black metallic paint to prevent rust and give them a pleasing appearance.

### No. 1430 Type

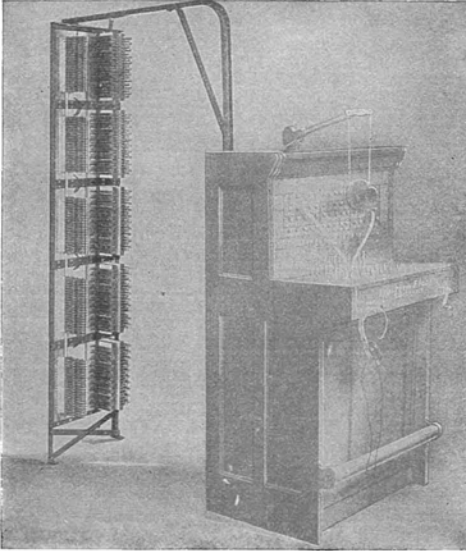

No. 1430D, E or F—Main Distributing Frame

These frames are built in units of two verticals, one vertical for supporting the terminal apparatus of the outside lines, and the other vertical for supporting the terminal apparatus of the inside lines.

Facilities for cross connection between the inside and outside lines are provided by the distributing rings on the back of each protector group. These frames are designed to be supported by the switchboard sections.

Each unit will accommodate 100 metallic telephone lines by using the protector groups described and illustrated under "Protector Groups."

(See table following for ordering data.)

These frames have the following important features:

**1. Steel framework.** The framework is of steel, forming a rigid support for the apparatus.

**2. Ease of access.** The framework is so constructed that cross connections and inspections can be easily made.

**3. Unit Type.** The framework is built in 100 line units and is so arranged that several units may be lined up to form a frame of larger capacity. It is only necessary to purchase enough frame to handle your present requirements, and increase your frame capacity as your number of lines increases.

**4. Universal design.** All of the vertical mounting irons are arranged so that our standard protector groups can be mounted upon them. By the addition of a small steel supporting bracket, the No. 1430 type frame can be converted into the No. 1420 wall type frame described later.

**5. Minimum Floor Space.** Due to their compact design, these frames occupy very little floor space.

### No. 1420 Type

This frame is identical in construction to the No. 1430 type, differing only in the supporting bracket, which is arranged to secure the frame to the wall instead of to the switchboard.

#### INFORMATION AND PRICE

Code No.	Used with Switchboards	Capacity		Protector Groups Used		*List Price Each
		Inside Lines	Outside Lines	Inside Lines	Outside Lines	
1430E	Nos. 1220 to 1239.....	100	100-125	1435P	1435J or R	\$14.70
1430F	Nos. 1240 to 1259.....	100	100-125	1435P	1435J or R	14.70
1420B	Any non-multiple switchboard	100	100-125	1435P	1435J or R	11.50

\*The prices given above cover frame only. The protector groups required should be ordered separately; see "Protector Groups."

Telephone Apparatus and Supplies

## DISTRIBUTING FRAMES

### No. 1430 and 1420 Types—Continued

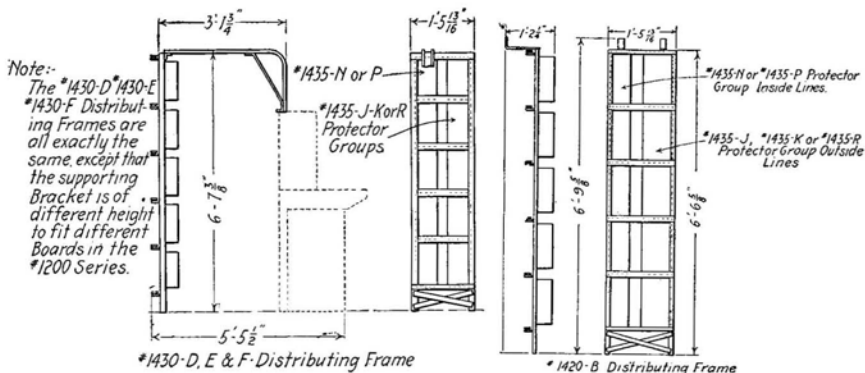

### No. 1431-A 20 Line Frame

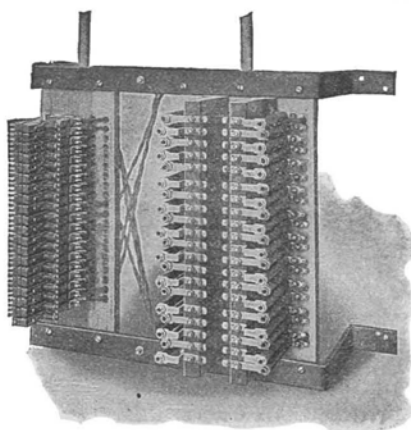

No. 1431-A —20-Line Main

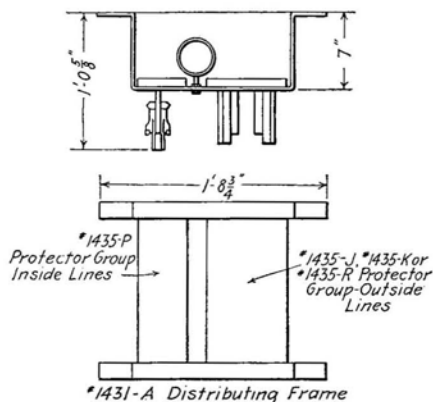

This frame has been designed to satisfy a demand for a small capacity, inexpensive, and yet sturdy distributing and protective equipment.

It is especially suitable for the small rural exchange owning and operating a No. 1800 or other switchboard, equipped for from 10 to 40 lines, with little prospect of immediate growth.

Where more than 20 lines are to be accommodated, two of these frames can be lined up, one above the other. Cross connection facilities are provided by rings on the back of the frame.

This frame is designed for mounting against the wall. The drilling is so arranged that our standard protector groups can be used.

In ordering this frame it will be necessary to specify the protector groups desired, consulting the following table:

#### INFORMATION AND PRICE

Code No.	Used with	Capacity		Protector Groups Used		List Price Each
		Inside Lines	Outside Lines	Inside Lines	Outside Lines	
1431A	Any small switchboard . . . . .	20	20-25	1435P	1435J or R	*\$4.70

\*The above price covers frame only. The protector groups required must be ordered separately.

## DISTRIBUTING FRAMES

### No. 1425 Type

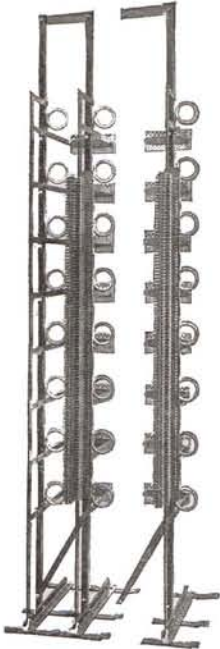

This shows two units of 1425C distributing frame lined up and bolted together. As many 100 line units as desired may be installed. Two units are necessary at the beginning of the frame; one unit for each additional 100 lines.

This is one 100 line unit of 1425C distributing frame. The Code No. 1425C covers the steel framework, distributing rings and fanning strip, but does not cover the protector groups and No. 65 terminal strips. The terminal strips for terminating 20 pairs of outside cable may be ordered as follows:  
 —No. 65 terminal strips. The carbon, mica and heat coil protector may be ordered as follows:  
 —No. 1435T Protector groups each accommodating 20 inside or switchboard pairs. These protector groups are suitable for both Central Battery and magneto lines.

This is a unit type frame, adapted for telephone central office or exchange protective apparatus where the No. 1420 or 1430 type frames are too small for present requirement or future growth.

**Fuses.** No provision is made for mounting on this frame abnormal current fuses. If it is considered necessary to equip certain lines with this type of protector, it is suggested that they be mounted elsewhere, such as on the wall or on a special frame constructed for the purpose.

**Construction.** This frame is rigidly constructed of steel angles and bar iron, and is made up in units of one vertical each, three verticals of this frame being shown in the accompanying illustration.

Each unit has a vertical bar which is arranged for mounting five No. 1435T protector groups which provide protectors of the carbon block and heat coil type for 100 magneto or central battery lines. Each protector group accommodates 20 lines.

This vertical protector bar is called the "vertical side" of the frame. The switchboard cables or inside lines are usually connected to these protectors.

Rubber covered distributing rings are placed conveniently, making it easy to run the jumper wires in a uniform, compact and neat manner, without going through more than one ring or making more than one turn.

The unit type of framework makes it possible, by lining up together a number of vertical units, to build a frame of any required capacity.

**Initial Equipment.** For initial equipment at least two units or verticals must be ordered and installed (which provide space for a maximum of 200 inside lines and 160 outside lines), as the No. 65 terminal strips to which the outside lines connect are mounted horizontally between adjacent vertical units, thus requiring at least two verticals to support a row of them. Eight of these terminal strips providing terminal facilities for 160 outside lines can be mounted between any two adjacent vertical units of the frame.

#### For Example:

1. No. 1425C frame provides space for 100 protectors (or 100 inside lines) and no outside lines.
2. No. 1425C frames provide space for 200 protectors (or 200 inside lines—\*see note) and 160 outside lines.
3. No. 1425C frames provide space for 300 protectors (or 300 inside lines—\*see note) and 320 outside lines.

\*NOTE: It is customary to not equip the first vertical unit with protectors, but to mount on it the required terminal equipment for miscellaneous inside circuits. The No. 53 terminal strip is adapted for mounting on the vertical side of those frames for this purpose. In ordering these strips for use on this frame, however, so specify on the order.

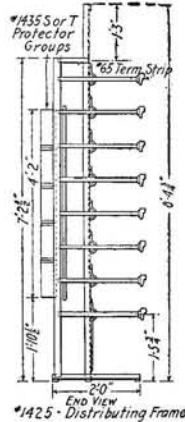

### INFORMATION AND PRICES

Code No.	Protector Groups Used		†List Price per Unit
	"Vertical Side" Inside Lines	"Horizontal Side" Outside Lines	
†1425C	Magneto or central battery lines—No. 1435T Misc. inside circuits—No. 53 terminal strip	No. 65 terminal strips	\$23.00

†The above Code No. and price includes one vertical unit of this frame and distributing rings only. The protector groups must be ordered separately.

## DISTRIBUTING RINGS

These are made from steel, and covered with vulcanized rubber tubing, which is very durable.



Code No.	Inside Diameter Inches	Used for	List Price Each
1	2 $\frac{7}{8}$	Main and intermediate distributing frames . . . . .	\$0.45
2	3 $\frac{7}{8}$	Main distributing frame No. 1 switchboards . . . . .	.47
3	3	Intermediate distributing frame No. 10 switchboard . . . . .	.45

## DROPS

In the following list the No. 4 type of drops are equipped with two electro-magnet spools each. The Nos. 19, 22, 35, 55 and 56 types are single spool drops with tubular iron shells and are cross-talk proof. The No. 19 type is employed especially on long bridging lines, toll lines, cord circuits, etc.

All drops are equipped with night bell contacts. The contacts of the No. 19F and No. 56F are made only while the drop is energized by the ringing current. In all the other drops listed below, the night bell contact remains closed until the drop is restored.

All drops will operate on alternating ringing current.

The No. 22 type drop is equipped with an extra winding for restoring the shutter when the call is answered.

The No. 35 type drop is equipped with two windings, one front and one back, and is adapted for selective central office signaling by grounding the middle of the winding and one side of the calling generator.

The Nos. 55 and 56 type drops are similar to the No. 19 type except that they are arranged to mount on 1 $\frac{1}{8}$  and 1 inch centers respectively, instead of 1 $\frac{3}{8}$  inch.

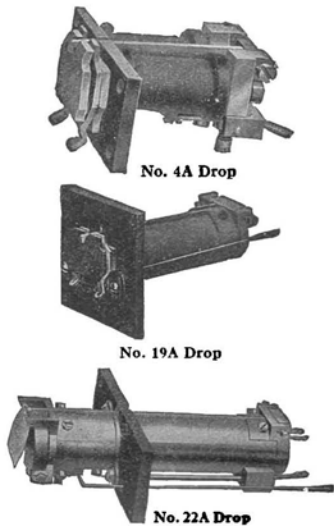

Code No.	Approx. Resistance Ohms	Finish On Shutter	List Price Each
4A	80	Black	\$1.60
4C	1000	Black	2.00
4D	500	Black	1.70
19A	525	Black	2.20
19B	600	Black	2.30
19C	1000	Black	2.50
19F	525	Black	2.50
19K	525	Brass	2.20
35A	300-300	Black	3.10
35B	500-500	Black	3.20
55B	600	Black	2.30
56A	525	Black	2.20
56B	600	Black	2.30
56C	1000	Black	2.50
56F	525	Black	2.50
56H	40	Black	2.00
56K	525	Brass	2.20
22A	Line 600, restoring 45	Aluminum	6.40

**DROP MOUNTINGS**

**No. 58 Drop Mounting**

Code No.	Number per Strip	Centers Inches	Size of Plate Inches	For Drops Number	Used on Switchboards Number	List Price Each
2	10	1 $\frac{3}{8}$	15 x 1	4, 19, 35, 42	101, 102, 1006, 1010, 1011	\$1.00
56	20	1 $\frac{3}{8}$	24 $\frac{9}{16}$ x 1	55, 56	9	2.20
57	15	1 $\frac{3}{8}$	24 $\frac{9}{16}$ x 1	4, 19, 35, 42, 44, 46, 51, 52, 55, 56	1102	1.60
58	15	1 $\frac{3}{8}$	21 $\frac{3}{4}$ x 1	4, 19, 35, 42, 44, 46, 51, 52, 55, 56	105, 1005	1.50
64	5	1 $\frac{1}{2}$	8 $\frac{1}{16}$ x 1	19	106	.70
69	10	1	11 $\frac{1}{16}$ x 1	56	10	2.30
71	15	1 $\frac{1}{4}$	21 $\frac{3}{4}$ x 1	55, 56	1200	2.00
72	15	1 $\frac{1}{4}$	23 $\frac{1}{16}$ x 1	55, 56	1200	2.20
73	10	1 $\frac{3}{16}$	17 $\frac{3}{4}$ x 1	4, 56	1200	1.70
74	15	1 $\frac{1}{16}$	17 $\frac{3}{4}$ x 1	56	1200	2.00
75	10	1 $\frac{3}{8}$	15 $\frac{5}{16}$ x 1	4, 19, 35, 55, 56	1800	1.60
76	4	1 $\frac{3}{16}$	7 $\frac{3}{16}$ x 1	4, 19, 35, 55, 56	1800	.80
77	6	1 $\frac{3}{16}$	10 $\frac{3}{16}$ x 1	4, 19, 35, 55, 56	1800	1.00
78	20	1	21 $\frac{3}{4}$ x 1	56	1200	2.60
79	8	1 $\frac{3}{4}$	21 $\frac{3}{4}$ x 1	55, 56	1200	1.60
80	10	1 $\frac{3}{4}$	21 $\frac{3}{4}$ x 1	55, 56	1200	1.60
81	8	1 $\frac{3}{4}$	23 $\frac{1}{16}$ x 1	55, 56	1200	1.60
82	10	1 $\frac{3}{4}$	23 $\frac{1}{16}$ x 1	55, 56	1200	1.50

**DROP SPACES**

Wooden strips with ebonized face arranged to mount interchangeably with drop mountings as listed below. Intended for use in place of drop mountings when a switchboard is not fully equipped.

Code No.	Size of Face Inches	Corresponding Drop Mountings	List Price Each
2	15 x 1	2	\$0.44
7	24 $\frac{9}{16}$ x 2 $\frac{1}{16}$	56, 57	.46
11	24 $\frac{9}{16}$ x 1 $\frac{1}{16}$	56, 57	.54
12	21 $\frac{3}{4}$ x 1	58, 59, 71, 78, 79, 80	.54
13	8 $\frac{1}{16}$ x 1 $\frac{1}{2}$	65	On request
14	17 $\frac{3}{4}$ x 1	73, 74	On request
*15	24 $\frac{9}{16}$ x 1 $\frac{1}{16}$	*	.70

\*Used on No. 9 equipment when a narrow space is required to line up drop mountings in adjacent panels.

**DUSTER**



Used for blowing out or dusting switchboards, distributing frames or anything that cannot be reached with a cloth or brush. Made entirely of wood and cannot cause a short circuit.

List No.	Length Inches	List Price Each
1	20	\$2.70
2	22 $\frac{3}{8}$	3.60
3	24 $\frac{3}{4}$	5.85
4	25 $\frac{1}{8}$	9.00
5	32 $\frac{1}{2}$	12.60

**DROPS**

**Piece Parts for No. 4A and 19A Drops**

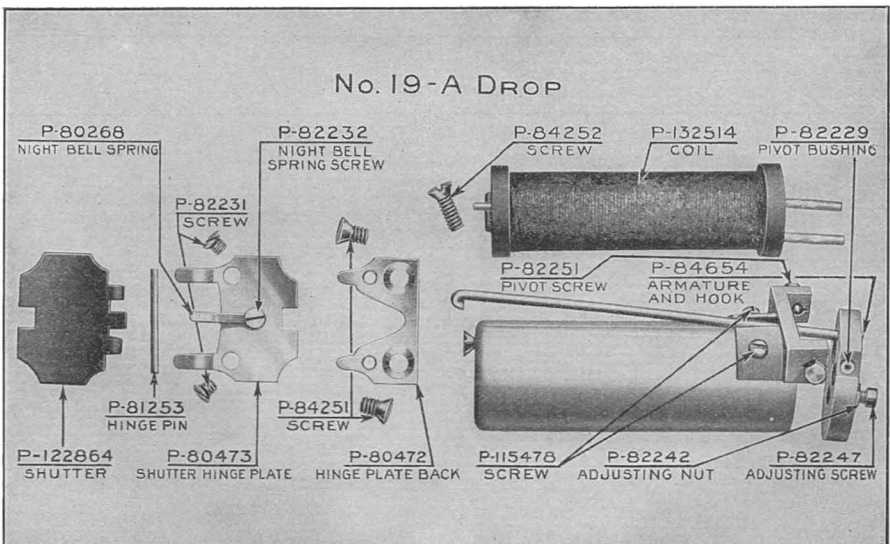
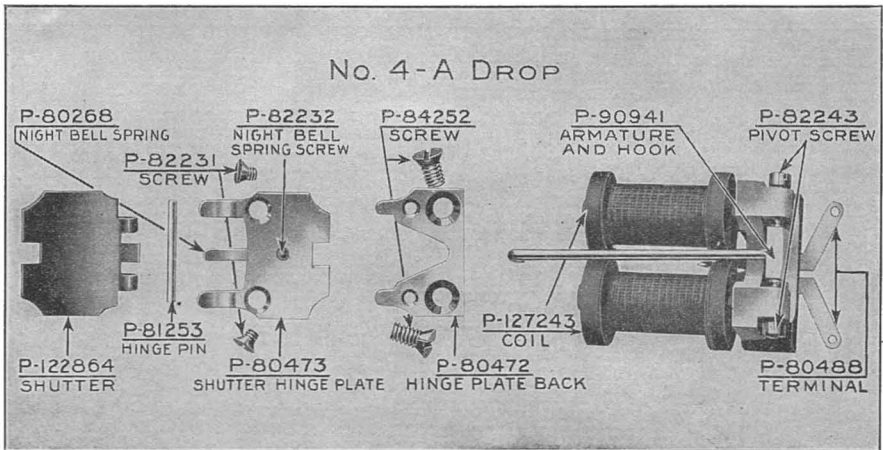

DROPS

Piece Parts for No. 22A and 56A Drops

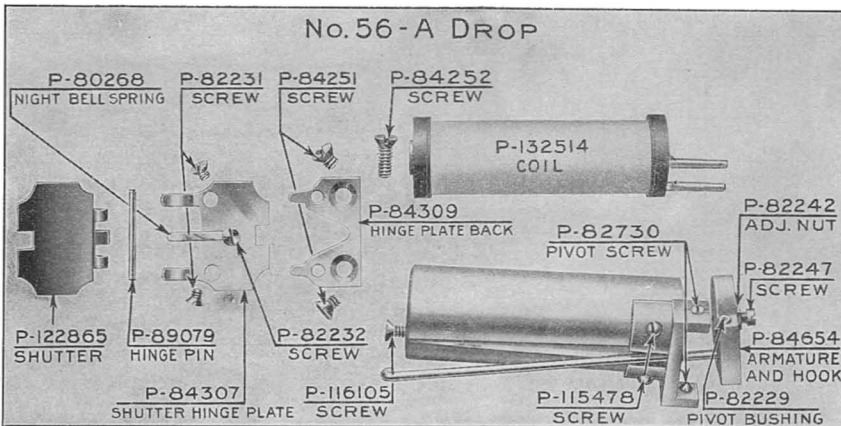
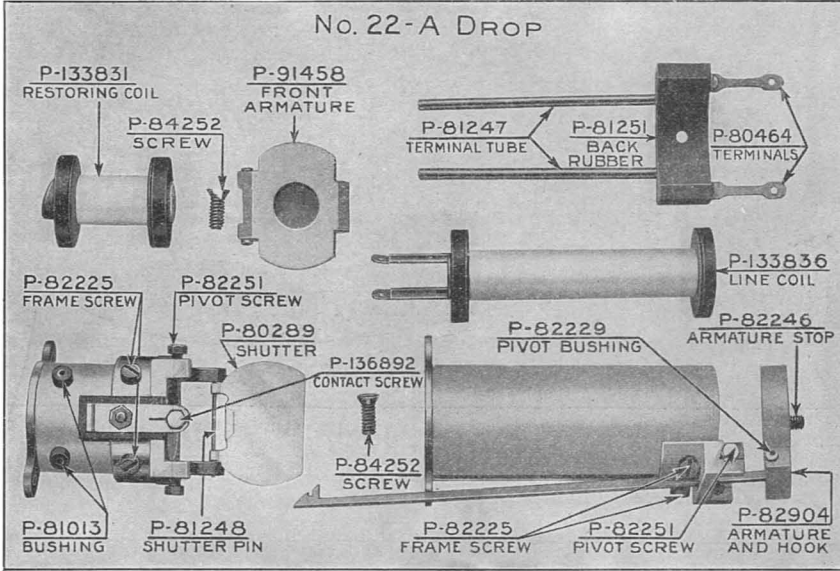

## EXTENSION BELLS For Alternating, Pulsating and Harmonic Currents

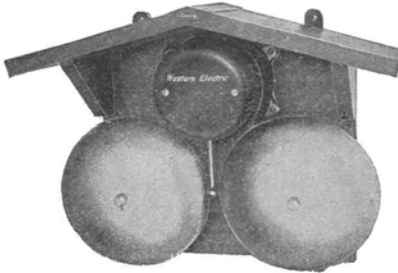

No. 342 Type

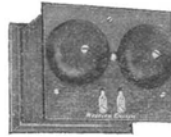

No. 43 and 127 Types

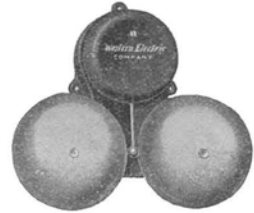

No. 392 Type

These extension bells are intended for auxiliary use in connection with wall, desk or telephone arm telephones. They consist of a ringer on a suitable mounting and two line terminals or binding posts.

They are suitable for magneto or local battery service only, unless equipped with a two microfarad condenser wired in series with the ringer.

### No. 43 Type

Ringer mounted in an oak box. Approximate dimensions, width 5 $\frac{5}{8}$ inches; height 4 $\frac{5}{8}$ inches, depth 4 $\frac{5}{8}$ inches.		Resistance	Frequency	Use	List Price
Code No.	Ringer No.	Ohms	Cycles	Each	Each
43F	6AG	1000	....	Bridging selective service	\$4.30
43H	2FG	1600	....	Bridging non-selective service	5.30
43J	6BG	2500	....	Bridging selective service	5.30
43P	1AG	80	....	Series service	3.40
43W	418G	....	33 $\frac{1}{3}$	Harmonic selective ringing	6.90
43Y	41TG	....	50	Harmonic selective ringing	6.90
43AA	41UC	....	66 $\frac{2}{3}$	Harmonic selective ringing	6.90
43AB	41RC	....	16 $\frac{2}{3}$	Harmonic selective ringing	6.90

### No. 127 Type

Ringer mounted in an oak box. Approximate dimensions, width 6 $\frac{1}{2}$ inches; height 4 $\frac{7}{8}$ inches; depth 4 $\frac{5}{8}$ inches.		Condenser	Resistance	Use	List Price
Code No.	Ringer No.	No.	Ohms	Each	Each
127A	6AG	21D	1000	Bridging selective service	\$6.50
127E	38AG		1000	Bridging non-selective service	4.40
127F	38BG		2500	Bridging non-selective service	5.40
127G	38FG		1600	Bridging non-selective service	5.40
127H	*43NG		88	In railway simplex block circuits	4.80

\*Ringer is split wound and performs the functions of a split retardation coil as well as a ringer.

### No. 392 Type—Loud Ringing

Moisture-proofed loud ringing bells having a black finish metal cover and base with galvanized finish gongs.

When the extension bell is to be used on a central battery line a condenser must be connected in series with the ringer coils.

Base is arranged for mounting a No. 21D condenser. Condenser is not furnished, however, unless so ordered. The connecting leads to the ringer coils are so arranged that the condenser can be easily connected in series with the ringer without disturbing the line wires when desired.

Code No.	Resistance	Diameter	Use	List Price
No.	Ohms	Gongs	Each	Each
392A	1000	6 ins.	*Bridging non-selective service	\$8.60
392B	2500	6 ins.	Bridging selective service	9.20
392C	1000	6 ins.	*Bridging non-selective service	8.70
392D	2500	6 ins.	Bridging selective service	9.40
392E	1000	6 ins.	*Bridging non-selective service	9.00
392G	1000	8 ins.	*Bridging non-selective service	On request
392H	2500	8 ins.	*Bridging non-selective service	On request

\*Biasing attachment for selective ringing can be added if desired.

### No. 342 Type

Loud ringing bells for use in mines and other places where a bell protected from weather is desired. Consists of a No. 392 type bell mounted on a No. 149A backboard having a sloping roof which protects the bell from falling water and other substances.

Code No.	Bell Used	Resistance	Diameter	List Price
		Ohms	Gongs	Each
342G	392G	1000	8 ins.	On request
342H	392H	2500	8 ins.	On request
342J	392A	1000	6 ins.	On request
342K	392B	2500	6 ins.	On request

**FACTORY CALL SYSTEMS**

(See Mechanical Code Signaling Systems)

**FANNING STRIPS**



No. 2 Fanning Strip

Wooden strips intended for use with No. 22 type cable terminals.

Code No.	Capacity Pairs	Length Inches	Cable Terminals Used With:	List Price per 100
1	11	8 $\frac{5}{8}$	No. 22A	\$7.00
2	16	12 $\frac{3}{8}$	No. 22B, No. 22D	10.00
3	21	16 $\frac{1}{8}$	No. 22C, No. 22E	13.00



"Accurate"



"Pyrene"

**HAND FIRE EXTINGUISHERS**

**Accurate**

This fire extinguisher is ready for instant use, being constructed to compel the immediate mixing of the chemicals the instant the extinguisher is turned bottom up. It will throw a stream of fire killing liquid heavily charged with carbonic acid gas from 40 to 50 feet, thus enabling the user to reach fires above the surface of the floor, in ceilings, curtains and elsewhere.

List price each (2 $\frac{1}{2}$  gal.), \$17.00

**Pyrene**

This fire extinguisher consists of a double acting pump of one quart capacity and is easily operated by hand, throwing a stream to a distance of about 30 feet. Pyrene liquid is a combination of purely organic materials containing neither acid, alkali, salts nor moisture and will not stain or injure anything with which it comes in contact. Pyrene liquid when subjected to a temperature of 200 degrees F. or over is immediately transformed into a heavy, dry, cohering, non-poisonous gas blanket which surrounds the burning material, cutting off the air supply necessary for the life of the fire, and thereby extinguishing it.

List price each (brass), \$14.00



No. 1B Foot Switch

**FOOT SWITCHES**

Code No.	Springs	Used	List Price Each
1B	Makes one contact	With dispatcher's telephone set	\$8.10
3B	Makes two and breaks one contact	With way station telephone sets	8.10

**FOOT SWITCH ATTACHMENTS**



No. 1A Foot Switch Attachment

Code No.	Length Inches	Use and Description	List Price Each
1A	12	With all types of foot switches.....	\$2.50
1B	24	With all types of foot switches.....	2.50
2A	23	$\frac{3}{4}$ in. black enameled conduit equipped with a $\frac{3}{4}$ in. T.&B. bushing at one end. Used to protect wires entering foot switches.....	1.30

Telephone Apparatus and Supplies

## FLASHING RECALL OUTFIT For Magneto Switchboards

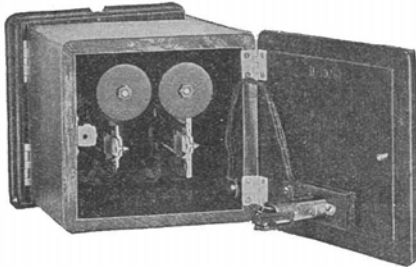

Apparatus Box, Open

These outfits are intended for connecting with the regular night alarm contacts of "clearing out" or "supervisory" drops of magneto switchboards, and provide an intermittent flash on a pilot lamp common to each operator's position so as to give a distinctive and unmistakable signal to the operator whenever a "clearing out" drop falls.

With this equipment it is never necessary for a subscriber to ring in but once, as the first ring starts a flashing lamp signal which continues until he is answered and the "clearing out" drop is restored. These outfits are primarily intended for installation in connection with Western Electric Magneto switchboards equipped with combined jacks and signals mounted on Nos. 81 or 89 type signal mountings, but can be used with equally satisfactory results on any other type or make of switchboard equipped with "supervisory" or "ring-off" drops having night alarm contacts.

If the equipment is to be used on switchboards of other than Western Electric manufacture, the pilot lamp socket mounting must be arranged specially to fit into the available space. This means that some provision must be made for mounting one No. 32 lamp socket in some convenient place in the face of each switchboard position. This may be either below the "clearing out" drops or in a wooden or metal plate made to fit into some available space. If wood is to be the mounting, a  $\frac{1}{16}$  inch bit will make a hole into which the lamp socket fits.

Outfit No. 1 is for use in connection with single position switchboards and outfit No. 2 with two position switchboards. If more than two positions are to be served, as many No. 2 or No. 2 and No. 1 outfits together should be ordered as will take care of the positions to be served.

### Outfit No. 1

This outfit consists of all apparatus necessary to equip a one position switchboard with the flashing recall feature, except the pilot lamp mounting plate which fits in the same space as a strip of five combined jacks and signals (see listing of this mounting below), and is made up of the following:

One oak apparatus box approximately  $6\frac{1}{2}$  inches wide by  $6\frac{1}{4}$  inches high by 6 inches deep, containing the required number of relays and a No. 406A key for cutting the "flashing recall" or pilot lamp circuit in or out, as desired. Operating this key cuts out the flashing recall apparatus leaving the regular night alarm connected to the "clearing out" drop. This is usually desirable when the operator leaves the switchboard for any length of time, as at night or during certain hours of the day when calls are very few and the operator has other duties to perform besides attending the switchboard. This box is usually mounted on the wall or in some other convenient location where it can be easily reached.

- 1 No. 32 lamp socket.
- 1 No. 2N lamp.
- 1 Set of installing instructions.
- 1 No. 4D lamp cap.

List price of outfit No. 1 (less pilot lamp mounting), each, . . . . . \$33.00



Apparatus Box, Closed

### Outfit No. 2

This outfit consists of all apparatus necessary for a two position switchboard equipment except the mounting plate for pilot lamps and is made up of the following:

- 1 Oak apparatus box similar to the one furnished with the No. 1 outfit.
- 2 No. 32 lamp sockets.
- 2 No. 2N lamps.
- 2 No. 4D lamp caps.
- 1 Set of installing instructions.

List price of outfit No. 2 (less mounting plate for pilot lamps), each, \$34.80.



Lamp Socket Mounting Equipped with Lamp Socket and Lamp Cap

### Flashing Recall Lamp Socket Mounting per D-29030

This mounting plate occupies the same space as a strip of five No. 2 or No. 22 type combined jacks and signals mounted on No. 81 or No. 89 signal mountings, and is arranged to mount one No. 32 lamp socket. Size of plate,  $1\frac{3}{4}$  inches wide by  $6\frac{1}{4}$  inches long. Order one mounting plate for each pilot lamp to be installed (one for outfit No. 1 and two for outfit No. 2, etc.).

List price of mounting per D-29030, each, \$1.40.

**FUSES**

These will blow on 50 per cent. increase in current above rating. In ordering, specify the code number and ampere rating.

**Mica Fuses**



Mica Fuse, Western Union Style



Mica Fuse, Postal Style

These fuses are furnished either with copper or foil tips, and in either Western Union or Postal style. The fuse is mounted on a mica base, or inclosed between two strips of mica.

When ordering, always specify ampere capacity desired and it is best to send sample of fuse wanted (an old one will do). If this is not possible, be sure and give the following information:

- Length.
- Style (whether Western Union or Postal).
- Kind of terminals or tips (copper or tin foil).
- Use (whether for exchange or telephone protection).



No. 24 Type Fuse



No. 35A

**MICA FUSES FOR NO. 62A AND 68A PROTECTORS**

Will Mount on 1 Inch Centers

Code No.	Carrying Capacity Amperes	Slotted for Screws No.	List Price per 100	Code No.	Carrying Capacity Amperes	Slotted for Screws No.	List Price per 100
24A	1 1/2	10	\$2.00	24B	3	6	\$2.00
24B	1/2	6	2.00	24B	4	6	On request
24B	1 1/2	6	2.00	24C	2	10	2.00
24B	2	6	2.00				

**Indicator Alarm Fuses**

Will Mount on 1 1/4 Inch Centers

These have a spring which makes contact with an auxiliary bus bar and gives a signal when the fuse blows. They have a head which also gives a prominent visual signal when a fuse operates.

Code No.	Carrying Capacity Amperes	Slotted for Screws No.	List Price per 100	Code No.	Carrying Capacity Amperes	Slotted for Screws No.	List Price per 100
35A	1 1/2	10	\$9.20	35B	3	6	\$9.20
35B	1 1/2	6	9.20	35C	2	10	9.20
35B	2	6	9.20	35F	1/2	10	9.20



No. 7A



No. 11C



No. 12A



No. 47A

**Tubular Fuses**

With Fiber Shell

These fuses are regularly furnished in 7 amperes capacity unless otherwise specified, although fuses of from 1 to 8 amperes capacity can be furnished if so ordered. The No. 12 fuse contains a heat coil.

Code No.	Used with Protectors Nos.	List Price per 100
7A	7, 61, 77 types	\$16.60
11C	58A, 58B, 59A, 79A	22.50
12A	12A	47.30

With Porcelain Shell

Code No.	Capacity Amperes	Used	List Price Each
47A	7	At telephone stations as an outside fuse in connection with No. 60A protector	On request
47B	14	At telephone stations as an outside fuse in connection with No. 79A protector	On request

**TELEGRAPH FUSES**

For Use with Fuse Blocks in Telegraph Service



Telegraph Fuse

List No.	Capacity, Amperes	Length	*List Price Each
2760	0-5 as specified	4 5/8 ins.	\$0.20

\*F. O. B. Providence, R. I.

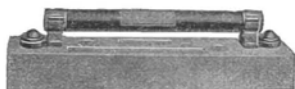

No. 2750



No. 2751

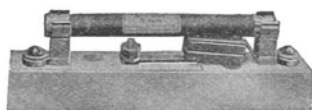

No. 2752

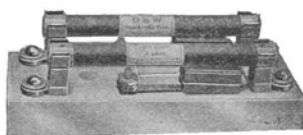

No. 2753



No. 3



No. 5A



No. 7 Type

## FUSE BLOCKS

### Without Fuses

#### For Telegraph Service

List No.	Type	Description	List Price
2750	Single	Porcelain fuse mounting 1 x 6 ins. with one pair of brass spring fuse clips on 4 1/8 in. centers.....	\$0.30
2751	Double	Porcelain fuse mounting 2 x 6 ins. with two pairs of brass spring fuse clips on 4 1/8 in. centers.....	.50
2752	Single with arrester	Single porcelain fuse mounting, 1 x 6 ins., with one pair of brass spring fuse clips on 4 1/8 in. centers and a carbon block lightning arrester...	.60
2753	Double with arrester	Double porcelain fuse mounting, 2 x 6 ins., with two pairs of brass spring fuse clips on 4 1/8 in. centers and two carbon block arresters.....	1.00

Fuses for these Fuse Blocks listed on the preceding page.

## FUSE POSTS

### For Mica and Alarm Fuses

These are furnished with two sizes of fuse clamping screw. The larger screw is furnished with small capacity fuses and the smaller screw for those of large capacity. This is to guard against using a fuse of high capacity in a circuit designed for one of low capacity. The only exception to this rule is in the case of the No. 24C and No. 35C (2 amperes), which with the No. 5B post are to be used only in message register circuits. To further guard against using the wrong fuse, the post and fuse terminal designed for 1 1/8 amperes capacity circuits are nickel plated and tinned respectively, while those for circuits above 1 1/8 amperes capacity are copper plated.

In replacing a fuse it should therefore be noted that the finish of the fuse terminals and post is similar.

Code No.	Finish	Screw Number	Used with Fuse Number	List Price Each
1C	Tinned	10	24A, 35A	\$0.09
5A	Nickel plate	10	24A, 35A	.16
5B	Bras	10	24C, 35C	.16
7A	Tinned	10	24A, 35A, 35F	.125
7B	Tinned	10	24A, 35A, 35F	.125

95 Telephone Apparatus and Supplies

## GENERATORS

### Charging Generators

See Charging Machines, pages 124 and 125.

### Power Generators

See also Ringing Machines, pages 126 and 127.

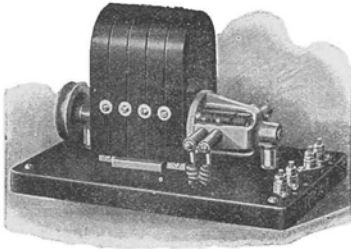

No. 16A

Code No.	Description	List Price Each
16A	A 5 bar, pulsating and alternating current, belt connected power generator. Delivers 103 volts A.C. and 72 volts pulsating at a speed of 1000 R.P.M.  Used to furnish power ringing for telephone central offices.  Mounted on a wood base 7 x 11 inches. Height, 7 inches. Has a cover for protection against dust and dirt.  Equipped with a grooved pulley 2 inches in diameter.	\$29.70

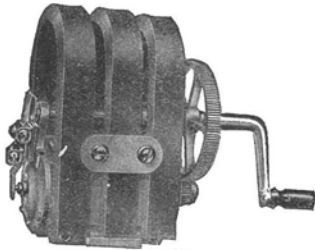

No. 22A

### Hand Generators

#### NOS. 22 AND 29 TYPES

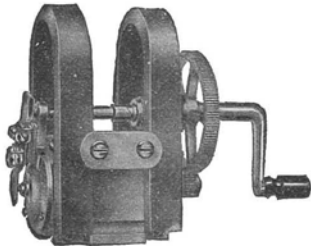

No. 22E

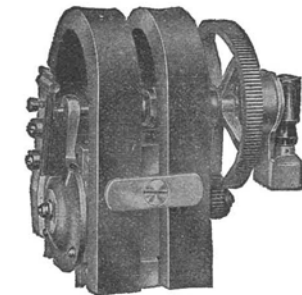

No. 29B

Telephone Apparatus and Supplies

Code No.	No. of Bars	Current	Armature Normally	Use	List Price Each
22A	3	Alternating	Open	Magneto telephone sets and switchboards.	\$5.30
22B	3	Alternating	Closed	Magneto telephone sets and test sets.	5.30
22D	3	Pulsating	Closed	Magneto telephone sets and switchboards.	5.30
22E	2	Alternating	Open	Magneto telephone sets.	5.30
22J	3	Alternating	Open	Magneto telephone sets.	6.00
22K	3	Alternating	Open	Test sets and switchboards.	5.30
22N	3	Alternating	Open	Test sets.	5.30
22S	3	Alternating	Open	Magneto telephone sets.	6.80
22T	3	Pulsating	Open	Magneto harmonic telephone sets.	6.30
22BA	3	Alternating	Open	Two cell No. 1317 type telephone sets. Similar to Nos. 22A, D, E and T respectively except equipped with black handles instead of nickel and rear mounting screws are omitted.	5.30
22BD	3	Pulsating	Closed		5.30
22BE	2	Alternating	Open		5.30
22BT	3	Pulsating	Open		6.30
29B	2	Alternating	Closed	Test sets.	5.40
29C	2	Alternating	Closed	Test sets.	8.70
29D	2	Alternating	Open	No. 1075A telephone sets.	10.60
29E	2	Alternating	Open	No. 1075B telephone sets.	10.60
29F	2	Alternating	Open	Test sets.	9.40

**GENERATORS**

**Hand Generators—Continued**

**NOS. 48 AND 50 TYPES**

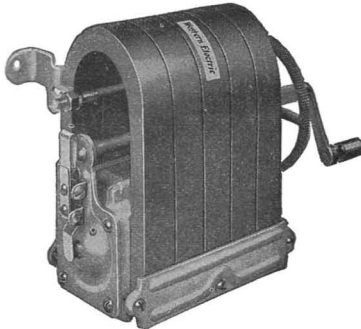

**No. 48A**

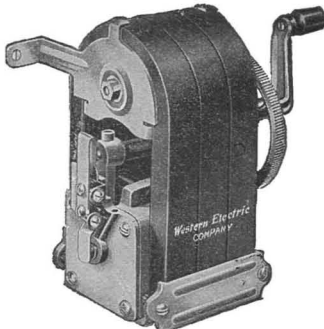

**No. 50A**

Code No.	Number of Bars	Current	Armature Normally	Used with	List Price Each
48A	5	Alternating	Closed	Magneto telephones	\$8.10
48B	5	Alternating and pulsating	Closed	Magneto telephones	9.70
48C	5		Alternating	Closed	Magneto mine telephones Mine signaling systems for ringing extension bells
48D	5	Alternating	Open		
48H	5	Alternating	Open	Switchboards	7.70
48K	5	Alternating	Open	Switchboards	8.20
48P	5	Alternating	Open	Switchboards	8.00
50A	3	Alternating	Closed	Magneto telephones	6.20
50C	3	Pulsating	Closed	Magneto telephones	7.20
50E	3	Alternating and pulsating	Closed	Magneto telephones	7.40
*50F	3		Alternating	Closed	Magneto telephones
*50G	3	Pulsating	Closed	Magneto telephones	7.20
*50H	3	Alternating and pulsating	Closed	Magneto telephones	7.40

\*The Nos. 50F, G and H differ from the Nos. 50A, C and E in that the rear mounting bracket is omitted and a black finished handle is used.

**HAND GENERATOR BOXES**

Regularly furnished in oak.

Code No.	Description	List Price Each
299F	5-bar A.C. generator No. 48A mounted in box 8 x 9 x 5 3/4 ins. ....	\$12.10
299G	5-bar pulsating and A.C. generator No. 48B mounted in box 8 x 9 x 5 3/4 ins. ....	13.60
303G	3-bar A.C. generator No. 50A mounted in box 6 3/4 x 8 7/8 x 5 1/2 ins. ....	7.90

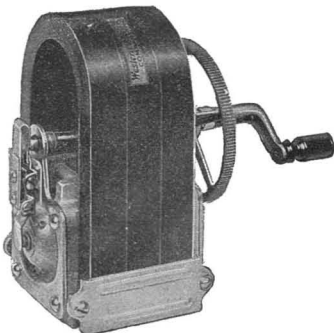

**No. 50F**

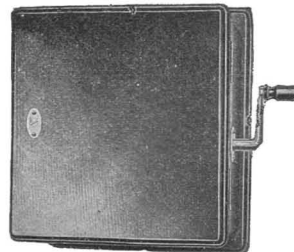

**No. 299F  
Telephone Apparatus and Supplies**

GENERATOR PIECE PARTS

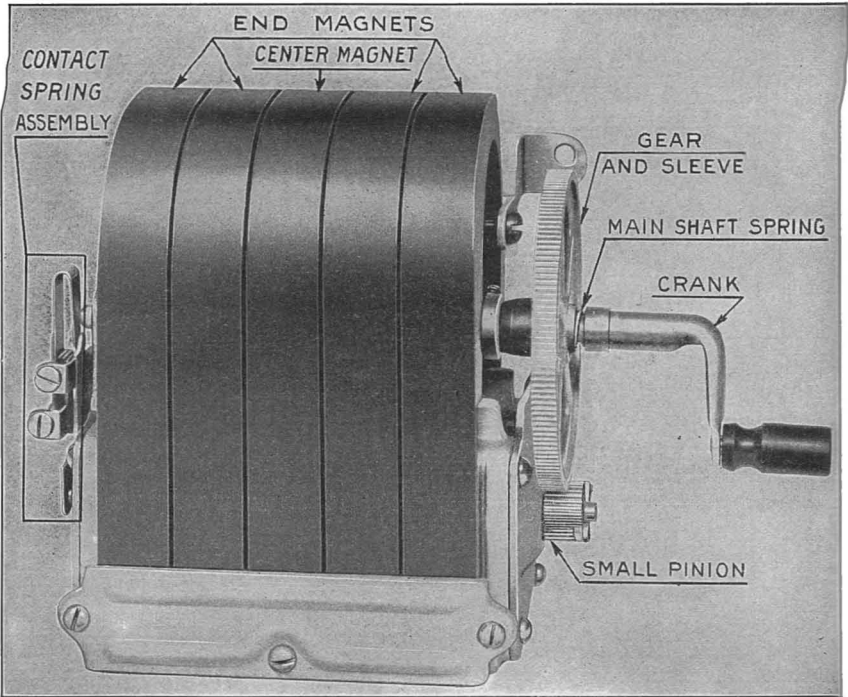

Name of Part	Part Number	Generators
Contact spring assembly	See footnote † P- 13583	Nos. 22A, B, D, T, BA, BD and BT
End magnets	See foot note * P- 41533	Nos. 22E and BE
	P-106117	No. 47A
	P-136786	No. 48A
Center magnet	P- 42979	Nos. 50A, C, E, F, G and H
	P-136790	Nos. 22A, B, D, T, BA, BD and BT
	P-136793	No. 47A
	P- 18376	No. 48A
	P- 20086	Nos. 50A, C, E, F, G and H
Gear and Sleeve	P-129359	Nos. 22A, B, E, T, BA, BE and BT
	P-126838	Nos. 22D and BD
Main shaft spring	P-18377	No. 47A
	P-19671	No. 48A
	P-131285 nickel finish	Nos. 50A, C, E, F, G and H
	P-136810 black finish	Nos. 22A, B, D, E and T
Crank—see footnote (a)	P- 36263 nickel finish	Nos. 22BA, BD, BE and BT
	P-131286 nickel finish	No. 50F, G and H
	P- 21624	No. 47A
	P- 42970	No. 48A
Pinion	P-101493	Nos. 50A, C and E
	P- 44621	Nos. 22A, B, D, E, T, BA, BD, BE and BT
	P- 44625	No. 47A
	P- 44626	No. 48A
Armature (wound)	P-129835	Nos. 50A, C, E, F, G and H
	P-113415	Nos. 22A, B, E, T, BA, BE and BT
	P-113434	Nos. 22D and BD
	P-138552	No. 47A
		No. 48A
		Nos. 50A and F
		Nos. 50C and G
		Nos. 50E and H

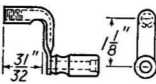

P-131285  
P-136810

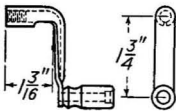

P-131286

†Order as follows: Example: 1 contact spring assembly for No. 22A generator.  
 \*The Nos. 22E and BE generators have only two magnets; P-18383 on the contact spring end and P-136786 on the crank end.  
 (a) Cranks P-131285 (nickel finish) and P-136810 (black finish) are the same except for finish and are interchangeable.

**GONGS**



No. 1 Gong



No. 3



No. 6

Code No.	Description	Dimensions, Inches		Finish	List Price Each
		Diameter	Height		
3	Cow gong . . . . .	2 x 1½	1¾	Nickel plate	On request
6	Sleigh gong . . . . .	1¾	1¾	Nickel plate	On request
10	Tea gong . . . . .	2½	1¼	Nickel plate	On request
15	Sleigh gong . . . . .	1¾	1¼	Nickel plate	\$0.50
17	Telephone set gong . . . . .	3	1	Nickel plate	.18
*20	Telephone set gong . . . . .	3	1	Black	.20
21	Large sleigh gong . . . . .	2	1¾	Nickel plate	.50
24A	Telephone set gong . . . . .	2	1¼	Black	.11
25A	Telephone set gong . . . . .	2½	¾	Black	.11
26A	Telephone set gong . . . . .	3	1	Black	.18
27A	Telephone set gong . . . . .	1¾	¾	Brass	.11
28A	Loud ringing extension set gong	6	1¾	Galvanized	.46
29A	Telephone set gong (for use on metal sets with inclosed gong) . . . . .	2½	¾	Black	.11
*30A	Loud ringing extension set gong	8	1¾	Galvanized	On request

\*Treated to resist the action of moisture and fumes.

**GONG MOUNTINGS**

Each gong mounting consists of a pair of gong posts or gong post extenders together with the necessary mounting screws. No. 2 also includes the necessary screws for fastening the gongs to the mountings.



No. 10

Code No.	Length of Post or Extender, Inches	Used With Gongs No.	Finish	List Price
				per 100
2	¾	6	Nickel plate	\$24.80
3	1¼	3 and 10	Nickel plate	28.10
7	1¼	3 and 10	Brass	22.50
13	1¾	3	Brass	49.50
14	¾	10	Brass	74.30



No. 3 Gong Mounting

**GONG NUTS**

No.	Description	Dimensions, Inches		Finish	List Price per 100
		Thread	Height		
P-19097	Knurled thumb nut used with No. 3 gong mounting . . . . .	10-32	1/8	1/2	Nickel plate \$5.00

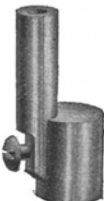

No. 7

**GROUND STRIPS**

(See No. 17 Type Protectors)

**HAND SETS**

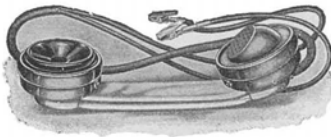

No. 1001A



No. 1002AC

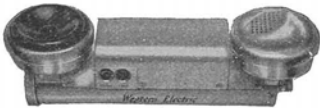

No. 1004A



No. 1B Hand Set Hanger



No. 40 Heat Coil



No. 67 Heat Coil



No. 70A Heat Coil



No. 1C Howler

Telephone Apparatus and Supplies

Code No.	Description and Use	List Price Each
1001A	For use as a lineman's test set on central battery lines. Equipped with No. 244W transmitter, No. 131W receiver and 3 ft. No. 348 cord which has two spring clips. . . . .	\$13.40
1001C	For use with portable magneto telephone sets, such as the No. 1330 and No. 1331 type. Equipped with No. 285W transmitter, No. 131W receiver, 6 ft. No. 366 cord. Has a push button switch in handle which performs the functions of a switch hook. . . . .	16.90
1001F	For use with street railway telephone sets, such as the No. 1278 type. Has a push button switch in handle which performs the functions of a switch hook. Equipped with No. 244W transmitter, No. 131W receiver, 5 ft. 2 in. No. 422 cord. . . . .	17.60
1002AC	For use in place of a regular local battery bridging or central battery desk stand or transmitter arm. Equipped with No. 141W receiver, No. 267W transmitter, 4½ ft. No. 318 cord. . . . .	14.20
1004A	For use in forest reserve service or wherever a compact, light and self-contained portable instrument is required. Particularly adapted for use by patrolmen. Signaling is accomplished by means of high frequency interrupted current created by means of an induction coil, vibrator and battery contained in the handle. This signaling current causes a howler, located at the other end of the line, to emit a shrill, sharp tone. Hand set consists of a receiver and transmitter and contains an induction coil, vibrator and No. 505 Eveready battery. Signaling is accomplished by pressing one button, another button being provided which must be held depressed while talking. . . . .	On request

**HAND SET HANGER**

Code No.	Description	List Price Each
1B	A black finished hanger for holding No. 1001 type hand sets. . . . .	\$4.50

**HEAT COILS**

Code No.	Description	Used with Protector Nos.	List Price Each
40	Cylindrical brass dummy coil. . . . .	4, 51, 65,	\$0.018
67	For central or local battery equipments. . . . .	78, 84, 87,	
70A	Cylindrical black fiber dummy. . . . .	89, 1168 and 1169 types	

**HOWLERS**

Code No.	Description	Use	List Price Each
1B	Mounted on iron bracket. Adjustable diaphragm and resonating horn. . . . .	In Nos. 1314A & E telephone sets	\$9.90
1C	Mounted on wooden base. Adjustable diaphragm and resonating horn. . . . .	With No. 1312A telephone set and No. 311A desk set box	9.90

INDUCTION COILS

The Nos. 10, 23 and 24 induction coils are mounted on wooden bases, the others are unmounted, unless otherwise specified.



No. 5

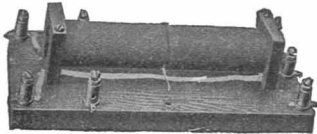

No. 10



Nos. 13, 29, 31 and 32



No. 20



No. 23

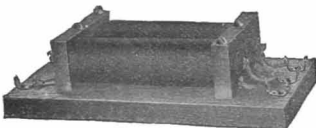

No. 24

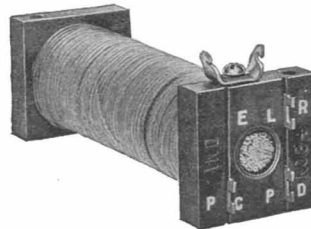

No. 34

Code No.	Dimensions, Inches			Used With	List Price Each
	Length	Width	Height		
5	4 $\frac{3}{8}$	1 $\frac{9}{16}$	1 $\frac{9}{16}$	Railway composite telephone sets.....	\$2.80
10	8 $\frac{7}{8}$	4 $\frac{1}{8}$	2 $\frac{3}{8}$	Operators' telephone set in magneto switchboards....	3.70
13	3 $\frac{1}{4}$	1	1 $\frac{5}{8}$	Local battery telephone sets.....	.90
20	4 $\frac{1}{2}$	1 $\frac{3}{8}$	1 $\frac{3}{4}$	Central battery telephone sets.....	1.40
23	4 $\frac{1}{4}$	1 $\frac{9}{16}$	1 $\frac{3}{8}$	Operators' telephone set in Nos. 9 and 10 central battery, private exchanges and magneto switchboards.	2.30
24	6 $\frac{3}{4}$	3 $\frac{1}{4}$	1 $\frac{1}{8}$	Operators' telephone set in No. 1 central battery switchboards and Nos. 1 and 2 toll boards.....	2.80
29	3 $\frac{1}{4}$	1	1 $\frac{5}{8}$	Local battery telephone sets in train dispatching circuits.....	1.20
30	4 $\frac{1}{2}$	1 $\frac{3}{8}$	1 $\frac{3}{4}$	Local battery telephone sets in train dispatching circuits.....	1.90
31	3 $\frac{1}{4}$	1	1 $\frac{5}{8}$	Mine telephone sets designed to resist the action of moisture and fumes.....	1.00
32	3 $\frac{1}{4}$	1	1 $\frac{5}{8}$	Local battery railway train dispatching telephone sets exposed to moisture or the weather.....	1.30
34	4 $\frac{9}{16}$	1 $\frac{3}{8}$	1 $\frac{3}{8}$	Operators' telephone sets in magneto multiple switchboards.....	2.30

**INTERRUPTERS**

(Sometimes Called Pole Changers)

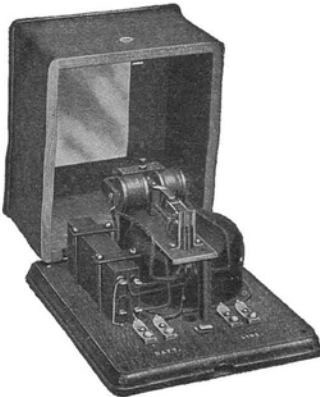

No. 62A. Open

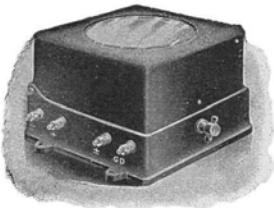

No. 84A. Closed

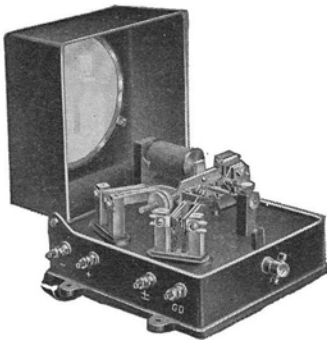

No. 84A. Open  
Telephone Apparatus and Supplies

**No. 62 Type**

Code No.	Description and use	List Price Each
62A*	An electrically operated interrupter for furnishing alternating current only. Designed particularly for railway telephone service or for ringing a small number of telephone bells on a low resistance line. Operates on 4 to 8 cells of dry battery and only when a push button or local contact on a ringing key is closed. Size of case, 6 $\frac{7}{8}$ inches wide, 8 $\frac{3}{4}$ inches high, 5 $\frac{1}{8}$ inches deep. . . . .	\$44.00

**No. 84 Type**

84A*	An electrically operated pole changer producing alternating and positive and negative pulsating current. Used for supplying ringing current in small exchanges for four party selective and straight ringing. Operating coil is wound for direct current from a 24 volt storage battery. Ringing current is taken from a battery of dry cells. Size of base, 8 x 8 inches. . . . .	\$42.00
84C*	Same as No. 84A, except that the operating coil is wound for current from a 36 volt storage battery. . . . .	\$42.00
84D*	Similar to No. 84A except that it is arranged to deliver alternating current only. Operating coil is wound for current from one Edison BSCO primary battery. . . . .	\$42.00
84E*	Same as No. 84A except that the operating coil is wound for current from one Edison BSCO primary battery. . . . .	\$41.00

\*Batteries not included in code number.

**Machine Interrupters**

A variety of interrupter attachments is available for mounting on Western Electric ringing machines. These are designed for interrupting battery current and ringing current supply in various circuits. Interrupters can be supplied to meet any requirement for such uses as tone test, howler, busy-back and machine ringing and with any desired frequency of interruption.

INTERRUPTERS

Piece Parts for Nos. 84A, C and E

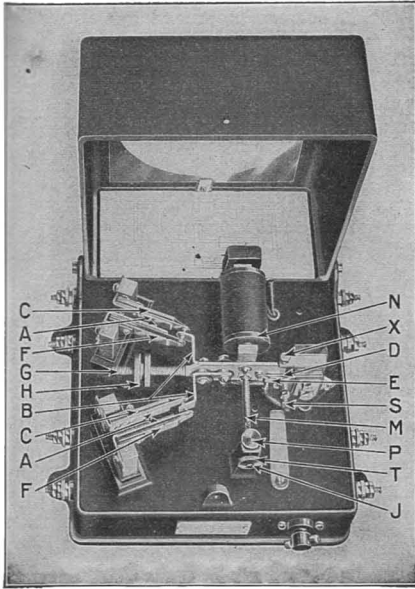

Top View of Nos. 84A, C and E Interrupters

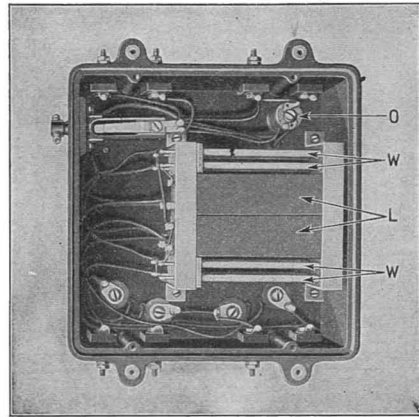

Bottom View of Nos. 84A, C and E Interrupters

When ordering give "P" number, indicated in the column headed with the Code No. of the interrupter for which the piece part is wanted, and also give name of part.

Key	Name	Code No. of Interrupter		
		84A	84C	84E
A	Inner ringing spring . . . . .	P-46665	P-46665	P-106359
B	Vibrator arm . . . . .	P-46651	P-46651	P-46651
C	Outer back ringing spring . . . . .	P-46667	P-46667	P-106359
D	Inner magnet spring . . . . .	P-46668	P-46668	P-46668
E	Outer magnet spring . . . . .	P-46669	P-46669	P-46666
F	Outer front ringing spring . . . . .	P-46666	P-46666	P-106358
G	Armature arm assembly . . . . .	P-46673	P-46673	P-46673
H	Weight nut . . . . .	P-46650	P-46650	P-103972
J	Spiral spring adjusting screw . . . . .	P-46648	P-46648	P-46648
L	Condenser . . . . .	No. 21J	No. 21J	No. 21J
M	Spiral spring . . . . .	P-106011	P-106011	P-106011
N	Electric magnet spools . . . . .	P-132829	P-128185	P-132828
O	Resistance across contacts . . . . .	No. 21B	No. 21B	Spl. No. 21 (A-38625)
P	Spring adjusting screw lock nut . . . . .	P-123818	P-123818	P-123818
S	Magnet spring adjusting screw . . . . .	P-39625	P-39625	P-39625
T	Spring adjusting screw nut . . . . .	P-46649	P-46649	P-46649
W	Resistance in series with condenser . . . . .	No. 18 AC	No. 18 AC	No. 18 AC
X	Pivot screw . . . . .	P-46654	P-46654	P-46654

## INTERRUPTERS

### Piece Parts for No. 84D

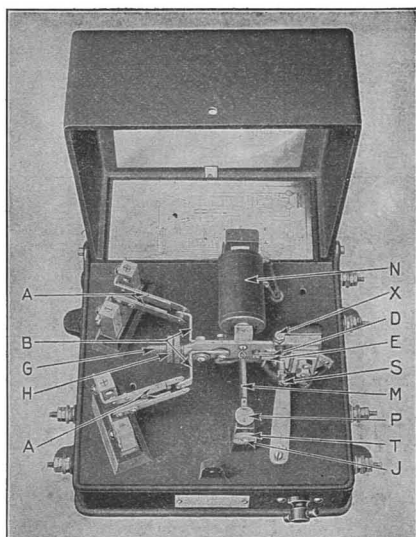

Top View of No. 84D Interrupter

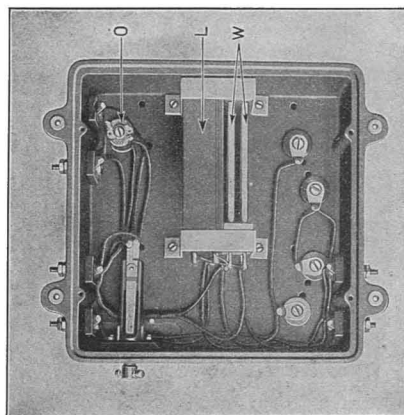

Bottom View of No. 84D Interrupter

When ordering give "P" number and name of part desired.

Key	Name	84D
A	Inner ringing spring . . . . .	P-103970
B	Vibrator arm . . . . .	P-46651
D	Inner magnet spring . . . . .	P-46668
E	Outer magnet spring . . . . .	P-46669
G	Armature arm assembly . . . . .	P-103975
H	Weight nut . . . . .	P-103972
J	Spiral spring adjusting screw . . . . .	P-46648
L	Condenser . . . . .	No. 21J
M	Spiral spring . . . . .	P-106011
N	Electric magnet spools . . . . .	P-133769
O	Resistance across contacts . . . . .	Spl. No. 21 (P-103977)
P	Spring adjusting screw lock nut . . . . .	P-123818
S	Magnet spring adjusting screw . . . . .	P-39625
T	Spring adjusting screw nut . . . . .	P-46649
W	Resistance in series with condenser . . . . .	No. 18 AC
X	Pivot screw . . . . .	P-46654

## INTERRUPTER RINGING OUTFITS

Interrupter ringing outfits, consisting of an electrically operated interrupter or pole changer and accessory apparatus, have been devised as a most economical means for furnishing ringing current in exchanges operating local battery lines or central battery offices that are too small for motor driven ringing machines or where power current is not available.

The interrupters require a comparatively small amount of current for operation and a minimum of attention, thus making for low maintenance costs. Three outfits are available.

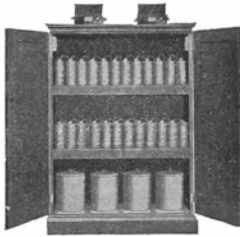

**No. 2 Interrupter Ringing Outfit,  
with 2 Extra Edison Batteries**

### No. 1 Interrupter Ringing Outfit

This outfit is intended for magneto switchboard service and constitutes a complete ringing equipment which makes use of one interrupter and one set of batteries each for ringing and operating. It consists of:

1 No. 84E interrupter (for description see page 102) for furnishing alternating and positive and negative pulsating current.

1 No. 1440 battery cabinet, oak finish, for holding one set of operating and ringing batteries.

1 BSCO No. 403 type, Edison 400 ampere hour battery for operating interrupter.

3 No. 62A protectors (for description see page 132) with 2 ampere fuses.

100 feet No. 14 B.R.C. wire.

List price of No. 1 outfit, \$89.78.

### No. 2 Interrupter Ringing Outfit

This outfit is intended for magneto switchboard service and constitutes a complete ringing equipment which makes use of two interrupters and two sets of both ringing and operating batteries. It provides one complete reserve ringing outfit for emergency service. The outfit consists of:

2 No. 84E interrupters (for description see page 102) for furnishing alternating and positive and negative pulsating current.

1 No. 1441 battery cabinet, oak finish, for holding two sets of ringing and operating batteries.

2 BSCO No. 403 type, Edison 400 ampere hour batteries for operating interrupter.

6 No. 62A protectors (for description see page 132) with 2 ampere fuses.

100 feet No. 14 B.R.C. wire.

List price of No. 2 outfit, \$176.22.

### No. 3 Interrupter Ringing Outfit

This outfit is intended for use in central battery central offices for furnishing straight alternating ringing current only. It makes use of an interrupter, transformer, retardation coil and condensers, and operates from a 22 volt storage battery or 18 cells of dry battery. In operating from dry batteries or any source of current other than storage battery, supplying at the same time current for other purposes, the retardation coil and condensers may be omitted. The small amount of current required makes the outfit economical from a maintenance standpoint.

The No. 3 outfit will ring 50 1600 ohm bells at the far end of a 400 ohm line.

It consists of:

1 No. 84A interrupter (for description see page 102) for furnishing alternating current only.

1 No. 116956 transformer.

1 No. 116957 retardation coil

27 No. 21E condensers.

List Price of No. 3 outfit, \$116.16.

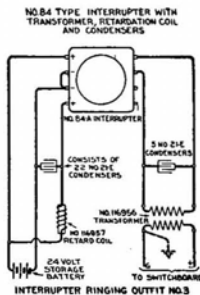

JACKS

Jacks Designed for Mounting in Strips



These jacks must be ordered in connection with jack mountings. See note under jack mountings.

No. 199

Code No.	Used with Plug No.	Used with Jack Mountings Nos.		List Price Each
92	109	18, 19, 113	10 per strip 20 per strip	\$0.70 .60
99	47, 116, 137	30, 80 or mounted singly	2 per strip Unmounted	.90 .36
138	110	108, 109, 110, 112	10 per strip 20 per strip	On request
141	110	108, 109, 110, 112	10 per strip 20 per strip	1.08 .94
*193	110	117, 118, 119, 120 122, 123, 125, 127	10 per strip 20 per strip	.70 .60

\*The No. 119 tool is designed for extracting and replacing the sleeve of the No. 193 jack.

Singly Mounted Punched Frame Jacks

SINGLE MOUNTING LUG, HORIZONTAL SPRINGS



Mounting Centers



No. 155

Horizontal:  $\frac{11}{16}$  in.

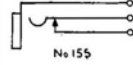
Vertical:  $\frac{39}{64}$  in. when mounted with lugs in same direction;  $\frac{5}{8}$  in. when mounted back to back in two rows.

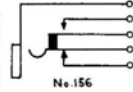
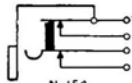
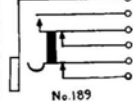
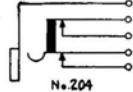
Code No.	Used with Plug Number	List Price Each	Code No.	Used with Plug Number	List Price Each		
 No. 149	149	47, 116	\$0.58	 No. 155	155	47, 116	\$0.64
 No. 152	152	47, 116, 103, 137	.36	 No. 156	156	47, 116	1.00
 No. 154	154	47, 116	1.00	 No. 189	189	47, 116	1.08
				 No. 204	204	47, 116	1.40

JACKS

Singly Mounted Punched Frame Jacks (Continued)

SINGLE MOUNTING LUG; VERTICAL SPRINGS



No. 160

Mounting Centers

Horizontal— $\frac{3}{8}$  in. for Nos. 159 and 160;  $\frac{7}{8}$  in. for Nos. 161 and 162;  $\frac{3}{4}$  in. for No. 163 and  $1\frac{1}{2}$  in. for No. 165.

Vertical— $\frac{3}{8}$  in. when mounted with lugs in the same direction;  $1\frac{1}{8}$  in. when mounted back to back in two rows.

Code No.	Used with Plug Number	List Price Each	Code No.	Used with Plug Number	List Price Each
159	110	\$0.36	162	110	\$0.70
160	110	.70	163	110	1.00
161	110	1.04	165	110	.80

DOUBLE MOUNTING LUGS; HORIZONTAL SPRINGS



No. 175

Mounting Centers

Horizontal:  $\frac{1}{2}$  in.  
Vertical:  $1\frac{1}{8}$  in.

Code No.	Used with Plug Number	List Price Each	Code No.	Used with Plug Number	List Price Each
169	47-116	\$0.58	175	47-116	\$0.56
170	47-116	.58	176	47-116	.86
172	47-116	.70	177	47-116	.86
173	47-116-103-137	.38	188	47	1.40
174	47-116	\$0.52			

## JACKS

### Singly Mounted Punched Frame Jacks (Continued)

DOUBLE MOUNTING LUGS; VERTICAL SPRINGS

Code No.	Used with Plug Number	List Price Each
No. 178 178	110	\$0.38
No. 179 179	110	.70
No. 180 180	110	1.06
No. 181 181	110	.70

**Mounting Centers**  
 Horizontal:  $\frac{3}{4}$  inch for Nos. 178 and 179;  $\frac{7}{8}$  inch for Nos. 180 and 181;  $\frac{3}{2}$  inch for No. 182 and  $1\frac{1}{2}$  inch for No. 184.  
 Vertical:  $1\frac{1}{2}$  inch.



Code No.	Used with Plug Number	List Price Each
No. 182 182	110	\$1.04
No. 184 184	110	.84

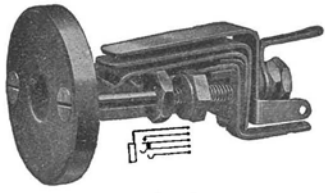

No. 77

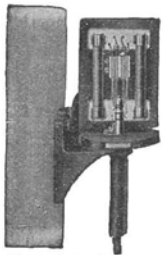

No. 186 Jack-Open



No. 190

Telephone Apparatus and Supplies

### Singly Mounted Cast Frame Jacks

Code No.	Use	List Price Each
77	Intended for use as operators' telephone jack with No. 85 plug.	\$1.48
186	A jack designed for mounting on poles; affords a means of connecting a portable telephone to the line. Contains protective apparatus consisting of: Two 500 volt 1 ampere D.&W. fuses. Two No. 1 protector blocks. Two No. 2 protector blocks. Two No. 3 protector micas. Lock will be furnished if specified in order. For use with No. 146 plug.	\$10.80
187	Same as No. 186 except it is not equipped with protective apparatus.	6.10
195	Intended for use in connection with the toll line circuit in the No. 1800 type switchboard. Used with No. 47 plug.	1.50
199	Intended for use with signal groups in connection with the toll line circuit in the No. 1800 type switchboard. Used with No. 47 plug.	1.40
208	Intended for use in Nos. 385A and B; 386A, B and C, and 389A jack boxes.	1.60
224	Intended for use in Nos. 385C and D; 386D, E and F, and 389B jack boxes.	2.00

### Restaurant Jack

190	These jacks are intended for use with No. 1020 type desk stands in restaurants and similar places where it is desirable to move the desk stand from table to table. Has black finished metal cover. Used with No. 85 plug.	\$3.90
-----	--	--------

**JACK BOXES**



No. 345A Jack Box

Code No.	Description	List Price Each
345A	<b>No. 345 TYPE</b> Oak box; designed for use in train dispatching circuits at dispatcher's office and is so arranged that two head sets can be connected to the line at the same time. Equipped with 1 No. 30 jack mounting, 2 No. 185 jacks and 2 No. 152 jacks. Approximate dimensions: Length, 5 1/2 ins. Width, 4 3/4 ins. Depth, 2 ins.	\$7.40

**Cordless Jack Boxes**

Oak boxes with nickel trimmings. Each box is equipped with a No. 116 plug attached by means of a dummy cord. The telephone jack boxes Nos. 385A and B, 386A, B and C, and 389A are so arranged that one telephone line can be terminated in each jack with which the box is equipped. A telephone set can be connected to any of these lines by inserting the plug in the proper jack. The telegraph jack boxes Nos. 385C and D, 386D, E and F, and 389B are so arranged that one telegraph line can be looped through each jack with which the box is equipped. The resonator set can be connected to any one of these lines by inserting the plug in the proper jack.



No. 385A Jack Box

Code No.	Line Equipment	Capacity	Equipped with Jacks	Service	List Price Each
<b>No. 385 TYPE</b>					
*385A	2	3	208	Telephone	\$6.80
*385B	3	3	208	Telephone	8.20
*385C	2	3	224	Telegraph	7.80
*385D	3	3	224	Telegraph	9.70

**Nos. 386 AND 389 TYPES**

Similar to No. 385 type except of larger capacity.

*386A	4	6	208	Telephone	\$10.40
*386B	5	6	208	Telephone	11.80
*386C	6	6	208	Telephone	13.30
*386D	4	6	224	Telegraph	12.30
*386E	5	6	224	Telegraph	14.30
*386F	6	6	224	Telegraph	16.20
389A	12	12	208	Telephone	23.60
389B	12	12	224	Telegraph	29.60

\*No. 17C apparatus blank furnished in unequipped positions.

**APPROXIMATE DIMENSIONS**

—Approximate Dimensions, Inches—

Code No.	Length	Width	Depth
385 Type	6 1/4	4 3/4	2 3/4
386 Type	6 3/4	7 1/4	2 3/4
389 Type	6 3/4	7 1/4	4 5/8

**JACK FASTENERS**

These fasteners serve the purpose of holding the jack and lamp socket mountings in place on the switchboard frame.



No. 15

No. 16

Code No.	Used On	List Price Each
15	No. 49 jack section having slotted stile strips . . . . .	\$0.108
16	No. 92 jack section having square stile strips . . . . .	.081

**JACK MOUNTINGS**

For central battery exchanges the multiple jack strips in each panel are separated into groups of five by thin white holly strips. Each group consists of one hundred jacks numbered 0 to 99. Each strip is divided into four parts, each having five jacks, by a distinctive mark so that an operator may readily choose the proper ones. It is also usual to furnish these jack mountings with a groove on the lower edge for marking the jacks for various purposes, such as signifying that several adjoining jacks are connected to one private exchange. This groove is shown on the No. 113 jack mounting.

In ordering, specify the number of jacks and the Code No., the Code No. of the mounting with the number per strip, together with the numbering desired. If holly strips are to be attached to the upper edge of any, the order should specify which ones. The proper number of jacks should be ordered to fully equip the mountings.

JACK MOUNTINGS (Continued)

Not Arranged for Number Plates

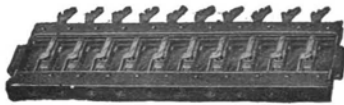

No. 18

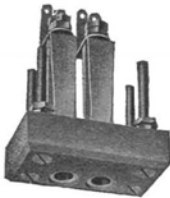

No. 80



No. 108



No. 109



No. 112

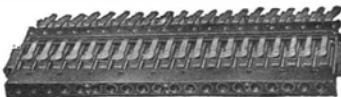

No. 113

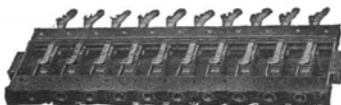

No. 19



No. 110

Telephone Apparatus and Supplies

Code No.	Used with Jack No.	No. per Strip	Face Dimensions Inches Length	Width	Switch-boards Used With	List Price
†18	92	10	7 3/8	3/8	No. 1	The price of the jack mounting is included in the price of the jack except in the case of the mountings for the No. 99 jacks—these jacks being furnished either with or without mountings, the price of the jack varying accordingly.
*30	99, 151, 152	4	3 3/4	1 1/4	All	
*78	99, 151, 152	6	5 1/8	1 1/4	No. 1	
*80	99, 151, 152	2	2 3/8	1 1/4	All	
†108	141	20	11 1/8	1/2	No. 10	
†109	141	10	11 1/8	1/2	No. 10	
†112	141	20	11 1/8	1/2	No. 10	
†113	92	20	7 3/8	3/8	No. 1	
†115	141, 166	20	10 1/2	1/8	No. 9	
†116	141, 166	10	10 1/2	1/8	No. 9	
†118	193	20	9 3/8	1/8	No. 1	
†120	193	20	9 3/8	1/8	No. 1	
†122	193	20	11 3/8	1/8	No. 1	
†127	193	10	9 3/8	1/8	No. 1	

\*For operator's telephone jacks.

†Numbered as specified, but furnished unnumbered unless otherwise ordered.

The usual method of numbering is to stamp the 10 per strip mountings 0-9, 10-19, etc., and the 20 per strip 0-19, 20-39, etc.

Arranged for Number Plates

These are not numbered. In ordering, specify the number of jacks and the code number, the code number of the mounting with the number per strip. The proper number of jacks should be ordered to fully equip the mountings.

Code No.	Used With Jack No.	No. per Strip	For No. Plates	Face Dimensions Inches Length	Width	Switch-boards Used With	List Price
19	92	10	{ 30A, 60D 108A	7 3/8	3/8	No. 1	The price of jack mountings is included in the price of the jack.
110	141	10	5B	11 1/8	1/2	No. 10	
117	193	10	{ 31A, 59B 109A	9 3/8	1/8	No. 1	
123	193	10	{ 31A, 32A 59B	11 3/8	1/8	No. 1	
125	193	20	124 type	11 3/8	1/8	No. 1	

**KEYS**

The following list represents a few of the most commonly used types of keys. A complete line of standard keys which will be found to satisfy any service requirement are manufactured, information on which will be furnished upon request.

Prices cover keys mounted on standard mountings.

**No. 69 Push Button Type**

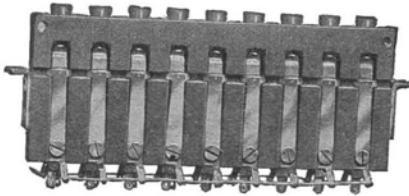

No. 69A Keys on No. 243 Mounting

Code No.	Description	List Price Each
69A	Push button type non-locking order wire key. Mounted in strips on various key mountings. Red plungers. Make two contacts when operated.	†\$1.00 *1.70

**No. 242 Push Button Type**

242B	Push button type non-locking order wire key with local contact. Mounted in strips on various key mountings. Red plungers. Make three contacts when operated. Similar in appearance to No. 69A.	†\$1.70 *2.20
------	--	------------------

**No. 92 Type**



No. 92B

92A	Single mounted, brass, push button type ringing key. Non-locking. Diameter of shell $\frac{3}{4}$ in. For $\frac{1}{8}$ , $\frac{7}{8}$ or $1\frac{1}{4}$ in. key shelf as specified. Breaks two and makes two contacts when operated.	\$1.40
92B	Listening key same as No. 92A except equipped with locking push button.	1.40
188C	Single mounted, brass, push button type, non-locking key. Diameter of shell $\frac{5}{8}$ in. For $\frac{1}{2}$ , $\frac{7}{8}$ or $1\frac{1}{4}$ in. key shelf as specified. Makes two contacts when operated.	1.40
464A	Single mounted, brass, push button type key. Non-locking. Diameter of shell $\frac{1}{2}$ in. For $\frac{7}{8}$ in. key shelf. Breaks one contact when operated.	1.00
464B	Same as No. 464A except makes one contact when operated instead of breaking one.	1.00
487A	Single mounted, push button type key. Non-locking. Mounts in drilling $\frac{1}{2}$ in. in diameter. Makes one contact when operated, the circuit being completed by means of a brass disc at the lower end of the push button coming in contact with the contact springs.	.70



No. 487A

†Except on Nos. 304, 308, 312 and 324 mountings.

\*On Nos. 304, 308, 312 and 324 mountings.

KEYS

No. 102 Type

Code No.	Description	List Price Each
102A	Combined listening and two-party ringing key, with indicator. Size of top $5\frac{1}{4} \times \frac{3}{4}$ ins. Listening key locking and makes two contacts when operated. Ringing keys, non-locking, each breaking two and making two contacts when operated.....	\$5.50
110A	Combined listening and two-party ringing key with indicator. Size of top $5\frac{1}{4} \times \frac{3}{4}$ ins. Listening key has local contact. Listening key locking, and makes three contacts when operated. Ringing keys non-locking, each breaking two and making two contacts when operated.....	5.80
121A	Single listening key. Size of top $5\frac{1}{4} \times \frac{3}{4}$ ins. Locking. Breaks two contacts and makes two when operated.....	2.70
156A	Combined listening and two-party ringing key. Size of top $5\frac{1}{4} \times \frac{3}{4}$ ins. Listening key locking and makes three contacts when operated. Ringing keys non-locking, each breaking and making two contacts when operated.....	5.00
275B	Combined listening, ringing and switching key. Size of top $5\frac{1}{4} \times \frac{3}{8}$ ins. Listening key, locking, breaks one and makes four contacts when operated. Ringing key, non-locking, breaks two and makes two contacts when operated. Switching key, locking, breaks two contacts when operated.....	6.40
275C	Combined repeating coil and two-way cut-off key. Size of top $5\frac{1}{4} \times \frac{3}{8}$ in. Repeating coil key locking, breaks one and makes three contacts when operated. Cut-off keys, non-locking, both make two and break two contacts when operated.....	5.20
456C	Two-way cut-off key. Size of top $5\frac{1}{4} \times \frac{3}{8}$ ins. Locking in both operated positions, breaking three and making one contact when operated.....	5.80

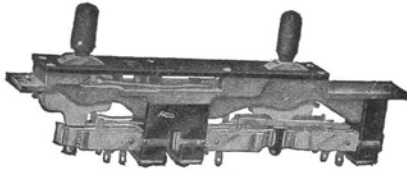

No. 102A

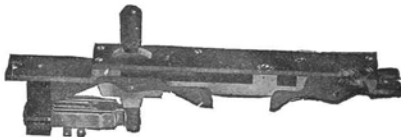

No. 121A

KEYS

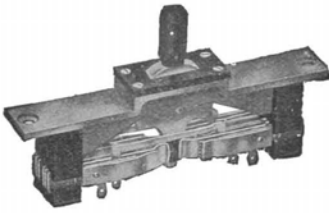

No. 104A

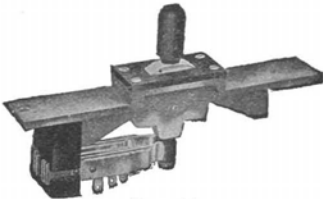

No. 115A

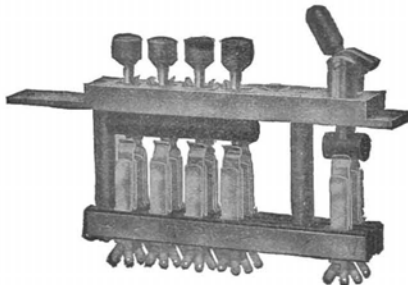

No. 227A

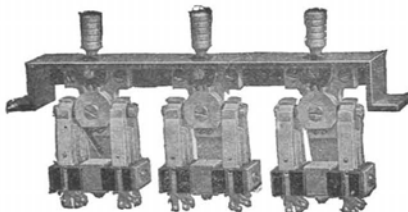

No. 251E

No. 104 Type

Code No.	Description	List Price Each
104A	Combined listening and ringing key. Size of top $1\frac{1}{2} \times \frac{3}{4}$ ins. Listening key is locking and makes two contacts when operated. The ringing key is non-locking and breaks two and makes two contacts when operated.....	\$3.10
115A	Single ringing key. Size of top $1\frac{1}{2} \times \frac{3}{4}$ ins. Non-locking. Breaks two and makes two contacts when operated...	2.20
116A	Combined listening and ringing key. Size of top $1\frac{1}{2} \times \frac{3}{4}$ ins. Listening key has a local contact. Listening key is locking and makes three contacts when operated. The ringing key is non-locking and breaks two and makes two contacts when operated.....	3.30
136B	Two-way switching key. Size of top $1\frac{1}{2} \times \frac{3}{4}$ ins. Locking in both operated positions, breaking two and making two contacts when operated.....	4.10
155A	Single listening key. Size of top $1\frac{1}{2} \times \frac{3}{4}$ ins. Locking. Breaks two contacts and makes two contacts when operated.	2.50
184A	Combined listening and ringing key. Size of top $1\frac{1}{2} \times \frac{3}{4}$ ins. Listening key is locking and breaks two and makes two contacts when operated. The ringing key is non-locking and breaks two and makes two contacts when operated.	3.20

No. 227 Type

227A	Listening and four-party ringing key with indicator. Size of top $5\frac{1}{4} \times \frac{3}{2}$ ins. Listening key locking. Ringing keys non-locking. All keys when operated break two and make two contacts.....	10.40
------	--	-------

No. 251 Type

251E	Combined listening and ringing key for use in connection with 3 x 7 cordless private branch exchange switchboards. Size of top $7\frac{5}{8} \times 1\frac{1}{8}$ ins. All listening keys locking, make three and break two contacts when operated. Ringing key, non-locking, makes two and breaks two contacts when operated...	10.40
251F	Switching key for use in connection with 3 x 7 cordless private branch exchange switchboards. Size of top $7\frac{5}{8} \times 1\frac{1}{8}$ ins. All keys are locking in operated position and all make two and break two contacts when operated.....	9.40
251G	Same as No. 251F except for method of strapping.....	9.40

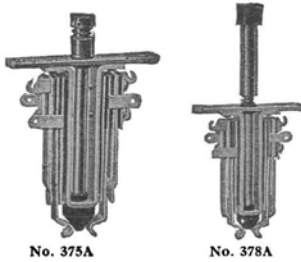

No. 375A

No. 378A

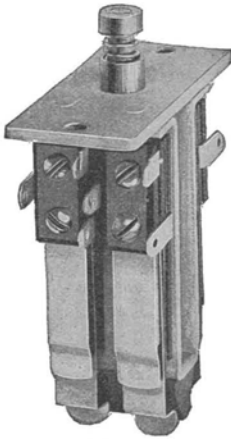

No. 392A



No. 406A

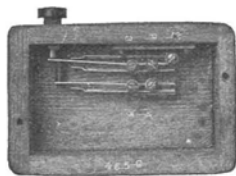

No. 465C. Bottom View  
Telephone Apparatus and Supplies

**KEYS**

**No. 375 Type**

Code No.	Description	List Price Each
375A	Push button type ringing key. Non-locking. Breaks two and makes two contacts when operated. . . . .	\$1.30

**No. 378 Type**

377A	Plunger type key for use with key lever. Locking or non-locking according to key lever used. For use in No. 6000A key. Makes two contacts when operated. . . . .	\$1.00
378A	Plunger type key for use with key lever. Locking or non-locking according to key lever used. Makes two and breaks two contacts when operated. . . . .	1.30
392A	Plunger type key for use with key lever. Locking or non-locking according to key lever used. Makes four and breaks four contacts when operated. . . . .	2.70

**No. 406 Type**

272A	Rotating plunger type listening key. For $\frac{1}{16}$ , $\frac{7}{8}$ or $1\frac{1}{4}$ in. shelf as specified. Locking. Breaks two and makes two contacts when operated. . . . .	\$1.60
272C	Similar to No. 272A except that it breaks three and makes three contacts, when operated, instead of breaks two and makes two. . . . .	2.50
272D	Similar to No. 272A except that it breaks four and makes four contacts, when operated, instead of breaks two and makes two. . . . .	3.30
406A	Single mounted, brass, rotating plunger type switching key. Locking. For $\frac{7}{8}$ or $1\frac{1}{4}$ in. shelf as specified. Diameter of shell $\frac{3}{8}$ in. Breaks one contact when operated. . . . .	1.40

**No. 465 Type**

465C	Push button type key mounted in an oak box. Size of box $4\frac{1}{8} \times 3\frac{1}{16} \times 1\frac{1}{2}$ ins. For use in train dispatching circuits for way station operators to cut in transmitter. Non-locking. Makes two and breaks one contact when operated. . . . .	\$3.10
465D	Push button type key mounted in an oak box. Size of box $4\frac{1}{8} \times 3\frac{1}{16} \times 1\frac{1}{2}$ ins. For use with No. 1317 type telephones which are not equipped with push buttons for central office selective signaling, but where this class of service is desired. Non-locking. Makes one and breaks one contact when operated. . . . .	2.00

KEYS

No. 468 Type

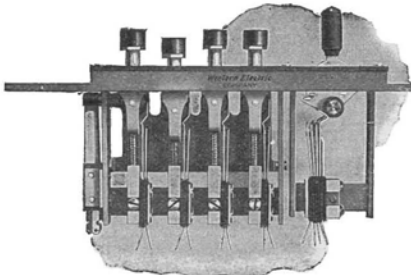

No. 468A Key

Code No.	Description	List Price Each
468A	A four-party harmonic ringing and listening key. The push buttons are made to have three positions—a normal, an operated, and a semi-operated or indicating position. The button last depressed remains in the indicating position until restored by the operation of one of the other buttons. The listening key is of the lever type and is locking. Size of top $5\frac{1}{4} \times 3\frac{3}{4}$ ins. . . . .	\$11.50
468C	Same as No. 468A, differing only in the combination of common ringing springs. Used to prevent ringing on busy lines. Size of top $5\frac{1}{4} \times 3\frac{3}{4}$ ins. . . . .	11.70
468D	A four-party harmonic master ringing key having contacts for starting relay. Size of top $5\frac{1}{4} \times 3\frac{3}{4}$ ins.	14.50
468E	An eight-party harmonic master ringing key having contacts for starting relay. Consists of four push buttons and a locking lever. Size of top $5\frac{1}{4} \times 3\frac{3}{4}$ ins. . . . .	17.90
468F	An eight-party harmonic ringing and listening key, having contacts for starting relay. Consists of four push buttons and a double locking lever. Size of top $5\frac{1}{4} \times 3\frac{3}{4}$ ins. . . . .	18.10
468G	A four-party harmonic ringing and listening key, having contacts for starting relay. Consists of four push buttons and a double locking lever, one side arranged for listening, the other for ringing back. Size of top $5\frac{1}{4} \times 3\frac{3}{4}$ ins. . . . .	19.50

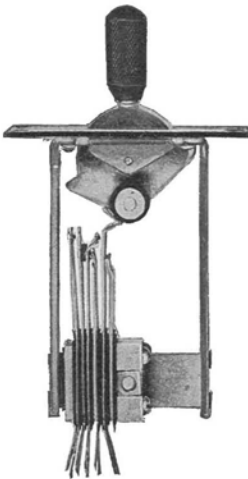

No. 479B

No. 479 Type

Combined listening and ringing keys. Black finished. Top  $2\frac{1}{4} \times 1\frac{1}{8}$  ins. Intended for use in cord and trunk circuits of No. 1801 type switchboards.

Unless otherwise specified, red lever handle is furnished on the No. 479B and black on the Nos. 479 A, C, D and E.

Code No.	Contacts		List Price Each
	Locking Position	Non-Locking Position	
479A	2 make and 1 break	2 makes	\$4.00
479B	4 make and 2 break		4.60
479C	2 break	2 makes	3.50
479D	2 make and 1 break	3 make and 2 break	5.20
479E	2 make	3 make and 2 break	5.00

**KEYS**

**No. 6000 Type**



**No. 6000A**

Code No.	Description	List Price Each
6000A	Wooden box equipped with 1 No. 377A key and 1 No. 6A key lever. Size of box (including key lever) $4\frac{3}{4}$ x $3\frac{5}{8}$ x $1\frac{1}{8}$ ins. Locking. Makes two contacts when operated. For use in dispatcher's telephone circuits. ....	\$3.80
6000B	Wooden box (No. 334 key mounting) equipped with 1 No. 136B key. Size of box $6\frac{1}{4}$ x $3\frac{7}{8}$ x $2\frac{7}{8}$ ins. Locking in both positions. Makes two and breaks two contacts in both positions when operated. For use in railroad service for connecting a telephone to any one of three separate lines. ....	7.40

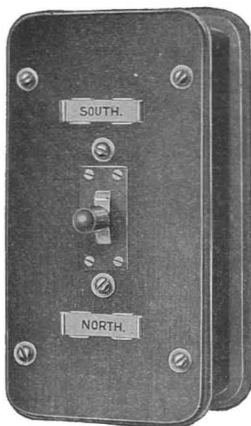

**No. 6000B**

**No. 6002 Type**

6002A	Wooden box equipped with 1 No. 378A key and 1 No. 23A key lever. Ebonized finish. Intended for use as switching key to connect a telephone instrument on either one or both of two lines. Size of box $5\frac{1}{2}$ x $3\frac{7}{8}$ x $1\frac{3}{8}$ ins. ....	\$4.70
6002B	Wooden box equipped with 1 No. 378A key and 1 No. 6A key lever. Ebonized finish. Intended for use as a switching key to connect a telephone instrument on either one of two lines. Dimensions same as No. 6002A. ....	4.10
6002C	Wooden box equipped with 1 No. 375A key. Ebonized finish. Intended for use as a switching key to connect a telephone instrument on either one of two lines. Dimensions same as No. 6002A. ....	3.40
6003A	Wooden box equipped with a push button type key. Size of box $6\frac{1}{8}$ x $3\frac{7}{8}$ x $2\frac{1}{8}$ ins. Non-locking. Makes three and breaks two contacts when operated. For operating a No. 62A interrupter. ....	6.40

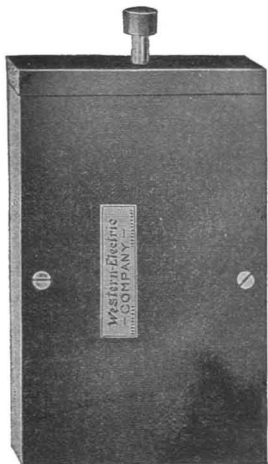

**No. 6002C**

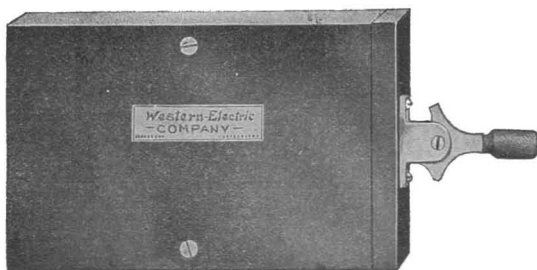

**No. 6002A**

**KEY LEVERS**



No. 6A

Code No.	Operated Position of Lever	Description	List Price Each
6A	Vertical	Used with lever type keys. Black handle. Locking..	\$0.70
6B	Vertical	Same as No. 6A, except red handle.....	.70
14A	Horizontal	Otherwise same as No. 6A.....	.70
14B	Horizontal	Otherwise same as No. 6B.....	.70

**KEY MOUNTINGS**

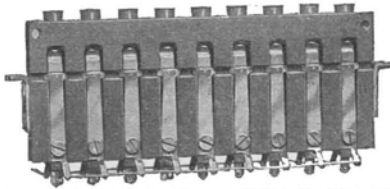

No. 243 Key Mounting Equipped With No. 69A Keys

The following are a few of our standard mountings for Nos. 69A and 242B order wire keys. A complete line of these mountings arranged to mount with any of our standard keys are manufactured, information on which will be cheerfully furnished upon request.



No. 303 Key Mounting Equipped With No. 69A Keys

Code No.	Number of Keys per Strip	Size of Top Inches	Keys Used with	The price of the key mounting is included in the price of the key.
243	9	6 <sup>1</sup> / <sub>16</sub> x 1/2	69A	The price of the key mounting is included in the price of the key.
248	5	4 <sup>1</sup> / <sub>16</sub> x 1/2	69A	
273	9	7 <sup>1</sup> / <sub>16</sub> x 5/8	242B	
303	8	6 <sup>1</sup> / <sub>16</sub> x 1/2	69A	
323	10	6 <sup>1</sup> / <sub>16</sub> x 1/2	69A	
324	12	6 <sup>7</sup> / <sub>8</sub> x 5/8	69A and 242B	

**KEY SPACES**

These are intended for use in place of keys where the full equipment of keys for which the key shelf is arranged is not installed or to fill in space between two keys. Key spaces can be furnished corresponding with respect to method of mounting and size and finish of top to any of our standard keys.

The following list represents a few of the most commonly used key spaces.

Code No.	Size of Top Inches	A Corresponding Key	List Price Each
102B	5 <sup>1</sup> / <sub>4</sub> x 3/4	102A	\$0.40
*102AH	5 <sup>1</sup> / <sub>4</sub> x 1 1/8	....	2.00
*102AJ	5 <sup>1</sup> / <sub>4</sub> x 3/2	227A	2.40
104B	1 1/2 x 3/4	104A	.34
251B	7 <sup>5</sup> / <sub>8</sub> x 1 1/8	251E	1.30

\*Has nickel plated top.

KEY PIECE PARTS

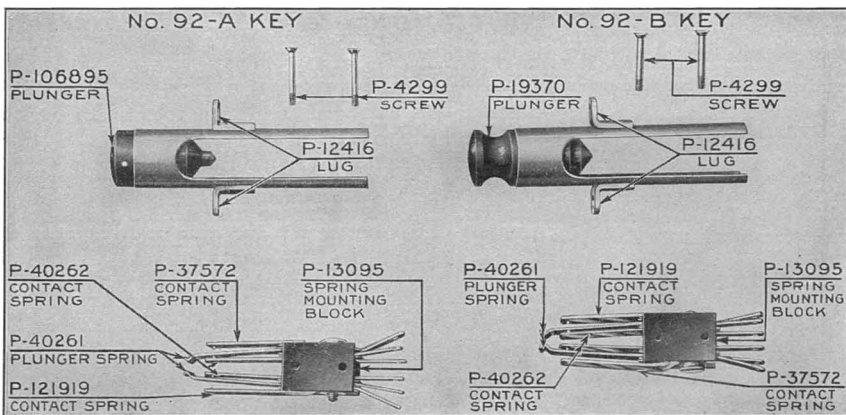
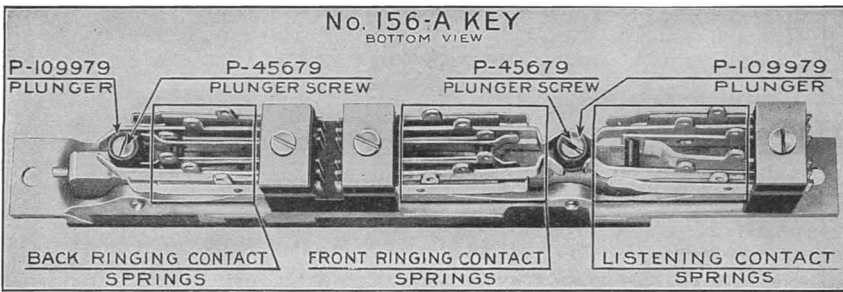
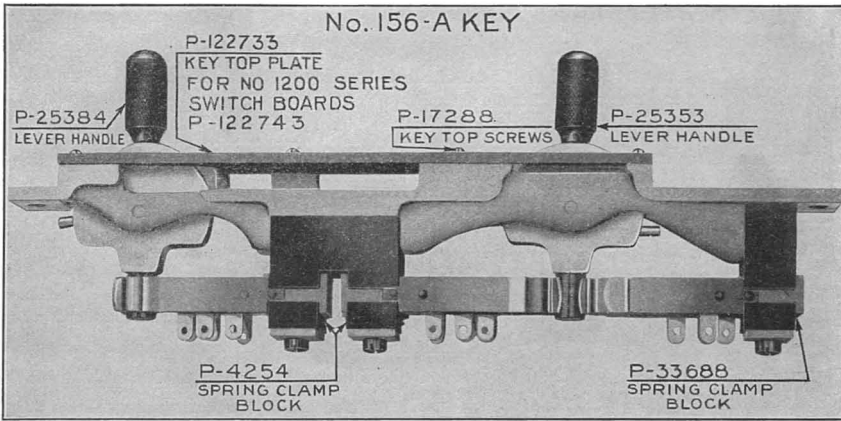

**SWITCHBOARD LAMPS**

The over-all diameter of the No. 2 type lamp is .3075 inch, and of the No. 4 type .515 inch.



No. 2



No. 4

Code No.	Voltage	Current Consumption		Used With Lamp Sockets No.	List Price Each
		Minimum Amperes	Maximum Amperes		
2A	4	.17	.21	12, 13, 30, 32	On request
2B	4	.27	.31	12, 13, 30, 32	\$0.54
2C	15	.09	.12	12, 13, 30, 32	.54
2E	20	.09	.12	12, 13, 30, 32	.54
2F	12	.097	.12	12, 13, 30, 32	.48
2G	24	.075	.115	12, 13, 30, 32	.48
2H	6	.27	.31	12, 13, 30, 32	.54
2J	24	.0225	.0375	12, 13, 30, 32	On request
2K	30	.09	.12	12, 13, 30, 32	On request
2L	10	.24	.26	12, 13, 30, 32	.54
2N	6	.12	.16	12, 13, 30, 32	On request
2P	8	.085	.10	12, 13, 30, 32	On request
2R	18	.09	.12	12, 13, 30, 32	On request
2T	35 to 47	.025	.0375 (35 volts)	12, 13, 30, 32	.54
2U	24	.035	.045	12, 13, 30, 32	.54
4A	4	.50	.60	16	On request
4B	8	.50	.60	16	.70
4C	22	.17	.21	16	.70
4D	12	.27	.31	16	On request
4E	18	.17	.21	16	.70
4F	20	.17	.21	16	.70
4G	24	.15	.185	16	.70

**LAMP CAPS**

**No. 2 Type**

Used with Nos. 12 and 13 Lamp Sockets



No. 2C



No. 2J



No. 2AY

Code No.	Symbol	Color	List Price Each	Code No.	Symbol	Color	List Price Each
2A	⊖	White opalescent	\$0.216	2AA	⊖	Red	\$0.27
2B	⊙	White opalescent	.216	2AB	⊖	White opalescent	.216
2C	⊕	White opalescent	.216	2AC	⊙	Red	.216
2D	⊖	White opalescent	.216	2AF	⊖	White opalescent	.216
2E	⊖	White opalescent	.216	2AG	⊖	White opalescent	.216
2F	⊙	White opalescent	.216	2AH	⊖	White opalescent	.216
2G	⊕	White opalescent	.216	2AJ	⊖	White opalescent	.216
2H	⊖	Red	.216	2AK	⊖	White opalescent	.216
2J	⊗	White opalescent	.216	2AM	⊖	White opalescent	.216
2K	⊕	White opalescent	.216	2AN	⊖	White opalescent	.216
2L	⊖	Green	.216	2AP	⊗	White opalescent	.216
2M	⊕	White opalescent	.216	2AS	⊖	White opalescent	.216
2N	⊙	Red	.216	2AT	⊖	White opalescent	.216
2P	⊗	Jeweled Red	.27	2AU	⊖	White opalescent	.216
2R	⊗	Jeweled Blue	.27	2AW	⊕	White opalescent	.216
2S	⊗	Jeweled Green	.27	2AY	⊖	White opalescent	.135
2T	⊕	Red	.27	2AZ	⊕	Red	.27
2U	⊖	Amber	.216	2BC	⊖	White opalescent	.216
2W	⊖	Blue	.216	2BD	⊙	White opalescent	.216
2Y	⊙	Green	.27	2BE	⊕	Green	.27

### LAMP CAPS

#### No. 4 Type



No. 4A

Used with Nos. 16 and 32 Lamp Sockets

Code No.	Symbol	Color	List Price Each	Code No.	Symbol	Color	List Price Each
4A	○	White opalescent	\$.027	4D	○	Red	\$0.405
4B	⊗	Jeweled Red	.405	4F	○	Green	.405
4C	⊗	Jeweled green	.405	4G	⊕	White opalescent	.405

#### No. 8 Type

Used with No. 30 Lamp Socket



No. 8A

Code No.	Symbol	Color	List Price Each	Code No.	Symbol	Color	List Price Each
8A	○	White opalescent	\$0.108	SU	⊕	White opalescent	\$0.216
8B	○	Clear	.216	SW	⊗	Jeweled red	.216
8D	○	Red	.216	SY	⊖	Green	.216
8E	⊙	White opalescent	.216	SAA	⊖	Red	.216
8F	⊙	White opalescent	.216	SAB	⊕	Green	.216
8G	⊖	White opalescent	.216	SAC	⊙	Red	.216
8H	⊖	White opalescent	.216	SAD	⊕	White opalescent	.216
8J	⊕	White opalescent	.216	SAE	⊗	White opalescent	.216
8K	⊙	White opalescent	.216	SAF	⊖	White opalescent	.216
8L	○	Green	.216	SAG	⊙	White opalescent	.216
8R	⊕	White opalescent	.216	SAH	⊕	White opalescent	.216
8T	⊕	White opalescent	On request				

### LAMP SOCKETS

#### Mounted Singly



No. 13

Code No.	Used With Lamps No.	Used With Lamp Caps No.	Used With Thickness of Shelf Inches	List Price Each
13	2 type	2	7/8	\$0.34
16	4 type	4	7/8, 1 1/8, 1 1/4, 1 1/2, as specified	1.10
32	2 type	4	7/8, 1 1/8, 1 1/4, 1 1/2, as specified	1.10

#### Mounted in Strips

These must be ordered in connection with the lamp socket mountings. See note under Lamp Socket Mountings.

Code No.	Used With Lamps No.	Used With Lamp Caps No.	Suitable for Lamp Socket Mountings No.	List Price Each
12	2 type	2	102, 122, 123, 125, 132, 134, 136, 137, 144	{ 10 per strip \$0.80 20 per strip .58
30	2 type	8	101, 102, 118, 123, 125	{ 10 per strip .80 20 per strip .58

Telephone Apparatus and Supplies

### LAMP SOCKET MOUNTINGS

In ordering, specify the number of lamp sockets and the code number, together with the code number of the lamp socket mounting. The proper number of lamp sockets should be ordered to fully equip the mountings.

Lamp socket mountings when equipped with No. 12 lamp sockets may have numbering stamped on the face of the strip, if desired, but will be furnished unnumbered unless otherwise specified in the order.

#### Not Arranged for Number Plates



No. 101 With No. 30 Lamp Socket

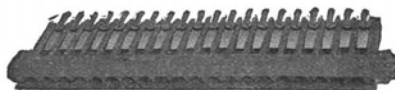

No. 102 With No. 12 Lamp Socket



No. 118 With No. 30 Lamp Socket



No. 136 With No. 12 Lamp Socket



No. 137 With No. 12 Lamp Socket

Code No.	Arranged for Lamp Sockets Nos.	No. per Strip	Face Dimensions—Inches		Will Mount With Jack Mountings Nos.	Type of Switchboard Used With	List Price
			Length	Width			
101	30	10	$9\frac{3}{16}$	$\frac{7}{16}$	127	No. 1	The price of the lamp socket mounting is included in the price of the lamp socket.
102	12 and 30	20	$9\frac{1}{16}$	$\frac{7}{16}$	118 and 120	No. 1	
118	30	20	$7\frac{3}{32}$	$\frac{7}{16}$	113	No. 1	
123	12 and 30	20	$10\frac{1}{2}$	$\frac{7}{16}$	115	No. 9	
125	12 and 30	10	$10\frac{1}{2}$	$\frac{7}{16}$	116	No. 9	
136	12	10	$11\frac{3}{16}$	$\frac{7}{16}$	109 and 110	No. 10	
*137	12	20	$11\frac{3}{16}$	$\frac{7}{16}$	108 and 112	No. 10	
*144	12	20	$11\frac{3}{16}$	$\frac{7}{16}$	122 and 125	No. 1	

\*Nos. 137 and 144 are the same except that on the No. 137 the lamp sockets are mounted on  $\frac{1}{2}$  inch centers and on the No. 144 on  $\frac{3}{4}$  inch centers.

#### Arranged for Number Plates

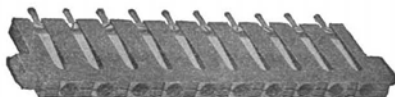

No. 122 With No. 12 Lamp Socket



No. 134 with No. 12 Lamp Socket

Code No.	Arranged for Lamp Sockets Nos.	No. per Strip	Face Dimensions—Inches		Arranged for No. Plates Nos.	Will Mount With Jack Mountings Nos.	Type of Switchboard Used With	List Price
			Length	Width				
122	12	10	$9\frac{3}{16}$	$\frac{7}{16}$	31A, 59B	117	No. 1	The price of the lamp socket mounting is included in the price of the lamp socket.
132	12	10	$10\frac{1}{16}$	$\frac{7}{16}$	31A, 59B	116	No. 9	
134	12	10	$7\frac{3}{32}$	$\frac{7}{16}$	60D, 108A	18, 19	No. 1	

LINE POLES



No. 3 Line Pole



End Section with Spreaders Extended No. 3 Line Pole



Part of End Section with Spreaders Closed No. 3 Line Pole



No. 4 Line Pole



Part of End Section Showing Method of Clamping to Wire No. 4 Line Pole



No. 5 Line Pole



Part of End Section showing Free Clamp. No. 5 Line Pole

Telephone Apparatus and Supplies

Hickory poles in three sections. Each section approximately 6 feet long.

The No. 3 and No. 5 are arranged so that the middle section can be omitted.

Code No.	Description	Used with	List Price Each
3	Adapted for use in connection with metallic circuits. The spreaders are of sufficient length to engage wires spaced a distance of 2 feet apart. With the pole is furnished 100 feet of two conductor No. 20 lamp cord equipped with cord tips.	Nos. 1330E, 1331E, 1332A and 1332E portable telephone sets.	\$14.90
4	Arranged for connecting a portable telephone to the line wire of a grounded circuit. Furnished with 100 feet of single conductor cord equipped with cord tips.	No. 1314A and E telephone sets.	12.40
5	Arranged for use in connection with metallic circuits. Can be connected to line wires in either horizontal or vertical planes which are spaced any distance up to 5½ feet, the top section being equipped with one fixed and one free clamp. The free clamp is controlled by a cord. Furnished with 100 ft. No. 20 two conductor lamp cord equipped with cord tips.	Nos. 1330E, 1331E, 1332A and 1332E telephone sets.	16.10

## CHARGING MACHINES

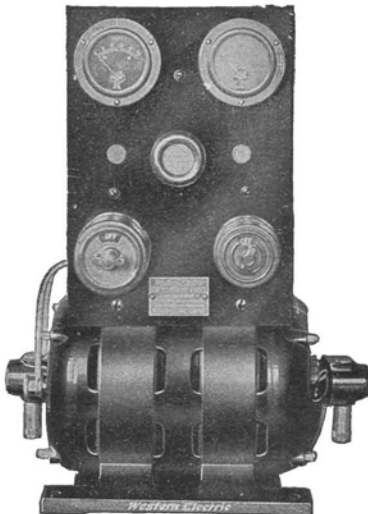

Battery Charging Unit, Front View

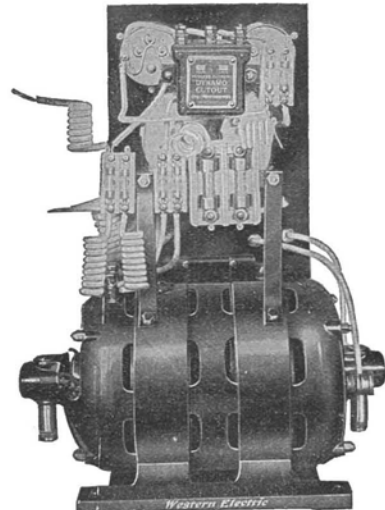

Battery Charging Unit, Rear View

## Battery Charging Units

Western Electric MIC and MCC type two-bearing motor-generator sets have been combined with a slate switchboard panel, arranged for mounting directly on the machine framework, to form battery charging units.

These battery charging units are designed for use in private branch and small central battery exchanges for charging eleven-cell storage battery sets, where two such sets are available so that one may be connected to the telephone system while the other is being charged.

The switchboards are equipped with all necessary switches and fuses, a generator field rheostat, automatic no-load and reverse current circuit breaker, charging current ammeter, battery voltmeter and other essentials.

The outfits listed in the following table are arranged for operation on either 60 cycle A.C. or D.C. circuits and for either 110 or 220 volts. The A.C. motors used in the sets are all of the single-phase type. Where two or three-phase A.C. power must be used, the outfit selected may be connected across one leg of the polyphase circuit, the amount of power required not being sufficient to seriously unbalance the power circuit.

To determine the proper charging unit to order for any given condition, it is necessary to consider the ampere capacity of the battery to be charged and the character of the power circuit on which the motor is to operate.

Select from the first two columns, headed "Storage Battery to Be Charged," the battery to be charged. Then on the same line, in the column headed by the type of power circuit available, find the Code No. of the proper charging unit, which should have an ampere output sufficient to charge the battery at the eight-hour discharge rate specified.

In exchanges, where future growth is expected, batteries partially equipped with plates may be furnished, as, for example, "D-5" (5 ampere) elements in "D-9" (10 ampere) tanks. The charging unit in this case should have an ampere output sufficient to charge a battery of the ultimate rating of 10 amperes.

## CHARGING MACHINES

### Battery Charging Units (Continued)

#### SIZE AND CAPACITY DATA

Type	Storage Battery to Be Charged— 8 Hour Discharge Rate Amperes	Listed on Page	Output of Charging Unit Amperes	Charging Unit Required				Fuses	
				A.C. 60 Cycle		D.C.		Ampere Charge	Capacity Required Discharge
				110 Volt Code No.	220 Volt Code No.	110 Volt Code No.	220 Volt Code No.		
BT	0.75	22	5	1531	2531	3531	4531	3	1
CT	1.50	22	5	1532	2532	3532	4532	3	2
PT	3.0	22	5	1563	2563	3563	4563	6	3
ET	4.5	22	5	1565	2565	3565	4565	6	5
B	.625	..	5	1531	2531	3531	4531	3	1
C-3	1.25	..	5	1532	2532	3532	4532	3	2
C-5	2.5	..	5	1533	2533	3533	4533	3	3
C-7	3.75	..	5	1565	2565	3565	4565	6	5
D-3	2.5	..	5	1533	2533	3533	4533	3	3
D-5	5.0	..	5	1565	2565	3565	4565	6	5
D-7	7.5	23	10	1000	2000	3000	4000	10	10
D-9	10.0	23	10	1000	2000	3000	4000	10	10
E-5	10.0	24	10	1000	2000	3000	4000	10	10

The speed of all sets is 1750 R.P.M.

#### DIMENSIONS AND APPROXIMATE SHIPPING WEIGHTS

Code Nos.				Overall Dimensions			Approximate Shipping Weight
				Length	Width	Height	
1531	2531	3531	4531	15¼ ins.	9 ins.	19¾ ins.	150 lbs.
1532	2532	3532	4532				
1533	2533	3533	4533				
1563	2563	3563	4563				
1565	2565	3565	4565				
1000	2000	3000	4000	18 ins.	10½ ins.	21 ins.	215 lbs.

#### Prices on Application

Orders should read:

1—Code No. 1565 Telephone Battery Charging Unit.

Deliveries:

Any of the above units for use on 110 volt, 60 cycle A.C. circuits can be shipped in four (4) weeks from receipt of order at factory. Any of the other units—220 volts A.C. or 110 or 220 volts D.C.— can be shipped in ten (10) weeks from receipt of order at factory.

A booklet giving complete instructions covering the installation, operation and maintenance of the battery charging units will be included with each outfit shipped.

## Mercury Arc Rectifiers

For Charging Storage Batteries

(See Rectifiers, Mercury Arc)

Telephone Apparatus and Supplies

## RINGING MACHINES

Western Electric ringing machines are recommended for furnishing ringing current where there is heavy exchange ringing and where the equipment is expected to grow rapidly. These ringing machines are of various types to meet various operating conditions and sizes of exchanges.

### Ringing Dynamotors

Ringing dynamotors are for use in exchanges where direct current power is available. They are in effect rotary transformers or converters, which change the direct current into 16 cycle alternating current and positive and negative pulsating current.

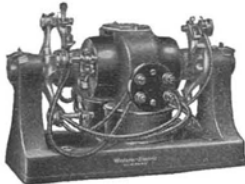

No. 4A Ringing Dynamotor

RINGING DYNAMOTORS  
DELIVERS 16 CYCLE A.C., AND POSITIVE  
& NEGATIVE PULSATING CURRENT

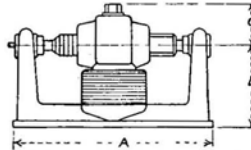

DIMENSIONS			
TYPE	A	B	WIDTH OF BASE
2	12 5/8"	5 1/2"	2 1/4"
4	14"	7 1/4"	2 1/2"
6	16 3/8"	8 3/8"	2 3/4"
7	20 1/2"	10 3/8"	3 1/2"
9'	26 3/8"	11 3/8"	5 1/2"

Code No.	Input Volts	Output of Generator End		Starting Box Required	Hand Wheel Required	Speed
		Watts	Volts			
2A	20 D.C.	15	75	No	No	950 R.P.M.
2B	110 D.C.	15	75	No	No	950 R.P.M.
2C	220 D.C.	15	75	No	No	950 R.P.M.
4A	20 D.C.	38	75	Yes	Yes	950 R.P.M.
4B	110 D.C.	38	75	Yes	Yes	950 R.P.M.
6A	20 D.C.	75	75	Yes	Yes	950 R.P.M.
6B	110 D.C.	75	75	Yes	Yes	950 R.P.M.
7A	20 D.C.	150	75	Yes	Yes	950 R.P.M.
7B	110 D.C.	150	75	Yes	Yes	950 R.P.M.
9A	20 D.C.	300	75	Yes	Yes	950 R.P.M.
9B	110 D.C.	300	75	Yes	Yes	950 R.P.M.

These dynamotors, with the exception of the No. 2 type, can be equipped with interrupters.

Prices upon application.

Orders should read:

No. . . . . ringing machine to give an output of . . . watts at 75 volts; primary volts. . . , equipped with necessary starting box for rear of board mounting with hand wheel and No. . . . interrupter (if desired).\*

\*NOTE: Interrupters for these machines consist of a shaft driven mechanism for providing tone test, busy back, trouble test, howler, etc. Many standing types are available and the one used depends upon the requirements of the installation.

### Ringing Generators—Belt Driven

These ringing generators are intended primarily for exchanges where only alternating current power is available. They are arranged for belt drive and furnished with pulleys. The code numbers do not include a motor, which should be separately specified if desired. The ringing generators furnish alternating current at 16 cycles as well as positive and negative pulsating current.

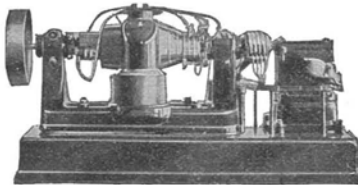

Ringing Generator with Interrupter

RINGING GENERATORS  
BELT CONNECTED  
DELIVERS 16 CYCLE A.C. AND POSITIVE  
& NEGATIVE PULSATING CURRENT

DIMENSIONS	
1-A	Same as No 2 Type
3-A	" " No. 4 "
5-A	" " No. 6 "
8-A	" " No. 7 "

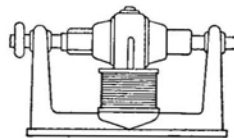

Code No.	Output of Generator		Size of Motor Required to Drive Without Interrupter	Standard Size of Pulley		Speed
	Watts	Volts		Face	Diameter	
1A	19	75	1/8 H.P.	1 1/2 ins.	4 1/4 ins.	950 R.P.M.
3A	75	75	1/4 H.P.	1 1/2 ins.	4 ins.	950 R.P.M.
5A	150	75	1/2 H.P.	1 1/2 ins.	4 ins.	950 R.P.M.
8A	300	75	3/8 H.P.	2 ins.	5 ins.	950 R.P.M.

These generators, with the exception of the No. 1A, are arranged for mounting an interrupter attachment.

Prices upon application.

**RINGING MACHINES**

**Ringling Generators, Belt Driven (Continued)**

Orders should read:  
 No. . . . . Ringing Machine to give an output of . . . . watts at 75 volts; complete with pulley . . . . inches in diameter; equipped with interrupter (if desired).

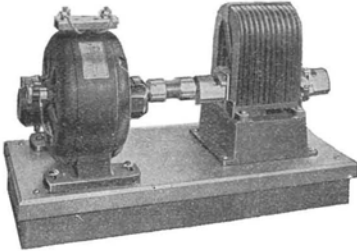

**Motor Generator Ringing Sets**

Western Electric motor generator ringing sets consist of direct current or single phase 60 cycle alternating current motors direct connected to magneto ringling generators. These sets furnish alternating ringling current only at 80 volts, 19 cycles. An attachment for obtaining positive and negative pulsating current is, however, available. These direct connected motor generator sets form a very compact, serviceable unit.

Code No.	Motor Volts	Output Watts	Code No.	Motor Volts	Output Watts
310025	115 D.C.	7	310042	110 A.C.	15
310026	230 D.C.	7	310043	220 A.C.	15
310030	115 D.C.	11	310060	115 D.C.	3
310031	230 D.C.	11	310061	230 D.C.	3
310032	115 D.C.	15	310065	115 D.C.	4
310033	230 D.C.	15	310066	230 D.C.	4
310035	110 A.C.	7	310070	110 A.C.	3
310036	220 A.C.	7	310071	220 A.C.	3
310040	110 A.C.	11	310075	110 A.C.	4
310041	220 A.C.	11	310076	220 A.C.	4

The above sets operate at a speed of 1150 R.P.M. Prices on application.

Orders should read:

No. . . . . Ringing Machine to give an output of . . . . watts at 80 volts and to operate on . . . . volts . . . . cycles; equipped with pulsating current attachment (if desired).

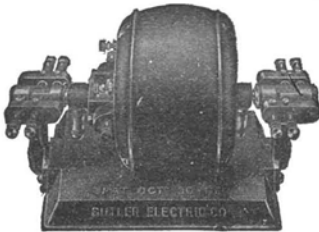

**Rotary Pole Changers**

These rotary pole changers are in reality rotating interrupters, consisting of a direct or alternating current motor with a commutator for interrupting the current. They are suitable for use in telephone central offices, serving a maximum of 1500 subscribers.

Code No.	Voltage Required to Operate	Power Consumption	Special Transformer Required	Kind of Current Furnished
A-24	24 volts D.C.	8 watts	Yes	A.C. only
A-26	36 volts D.C.	8 watts	Yes	A.C. only
A-110 D.C.	110 volts D.C.	8 watts	No*	A.C. only
A-220 D.C.	220 volts D.C.	8 watts	Yes	A.C. only
S-24	24 volts D.C.	8 watts	Yes	A.C. and pos. and neg. puls.
S-36	36 volts D.C.	8 watts	Yes	A.C. and pos. and neg. puls.
S-110 D.C.	110 volts D.C.	8 watts	No*	A.C. and pos. and neg. puls.
S-220 D.C.	220 volts D.C.	8 watts	Yes	A.C. and pos. and neg. puls.
A.C. 110	110 volts A.C.	8 watts	Yes	A.C. and pos. and neg. puls.
A.C. 220	220 volts A.C.	8 watts	Yes	A.C. and pos. and neg. puls.

\*Transformer required if one side of lighting circuit is grounded.

Ringling current for A.C. 110 and A.C. 220 must be taken from exchange batteries.

Prices upon application.

Orders should read:

No. . . . . rotary pole changer to operate from . . . . volts . . . . cycles with special transformer for . . . . volts D.C.

**Western Electric No. 16A Magneto Ringling Generator**

See Generators, page 96

**INTERRUPTERS AND INTERRUPTER RINGLING OUTFITS**

A complete description of Interrupters and Interrupter Ringling Outfits will be found on pages 102 and 105.

## MECHANICAL CODE SIGNALING SYSTEMS

### General

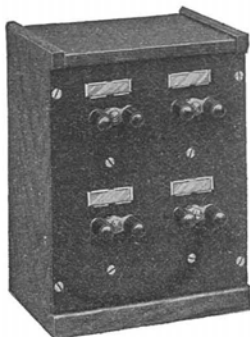

No. 1A. Signaling Set

one at a time, or to send a messenger in order to locate the desired person, frequently takes a considerable period of time, but with a mechanical code signaling system installed, the operator, clerk or other employee in the office or other central point gives a turn to a revolving key marked with the name of the individual wanted, which instantly signals the person desired wherever he may be.

**DESCRIPTION.** The equipment consists of a centrally located wooden cabinet equipped with revolving contact keys. A number of bells are mounted in different parts of the building which, when actuated from the central key cabinet, will ring simultaneously.

**OPERATION.** The key cabinet is equipped with a number of revolving keys. When the handle of a key is turned one-half revolution it slowly moves back to its original position, making and breaking an electrical contact a number of times at different intervals, thus forming a combination which is repeated four times before the key comes to a final stop. Each key produces a combination different from any of the other keys.

By placing the bells in such locations that, no matter where a person may be, he will always be within hearing distance of one of them, and by installing at a central point a key cabinet equipped with as many keys as there are persons in the organization who are apt to be frequently wanted on important matters, a call can be sent out for any one of them just by turning the key assigned to him. All bells will immediately sound the proper combination, and on hearing his call the person wanted steps to the nearest telephone and is in communication with the office immediately.

In addition to the regular signals described above, a special signal giving a continuous series of impulses to attract attention above all other signals can be furnished if desired. This special signal is intended to be used for emergency, fire, etc.

**CAPACITY.** The system can be furnished with keys for sending out 4, 6, 8, 10, 12, 14 and 16 different signals, thus producing maximum calling facilities for sixteen persons, which is usually all that average conditions require. When the special signal mentioned above is furnished this reduces by one the capacity for regular signals.

**BELLS.** It has been found that single stroke bells with 6 inch gongs will give satisfactory service under ordinary conditions. Any number and various sizes of bells can be combined to form one system.

**INSTALLATION.** The signaling system can be used alone or in connection with an Inter-phone System.

**1. Independently.** The signaling system can be installed and operated entirely separate and apart from any other system, and requires only two wires for its operation. As many bells as desired can be connected and made to simultaneously sound any desired code by turning the proper key in the key cabinet.

**2. With Intercommunicating Telephone Systems.** These signal sets can be connected directly to our inter-phones of System No. 1 without any change in the wiring of the instruments, or special bells. In this case, the bells on the instruments sound the code signals simultaneously whenever any one of the calling keys in the key cabinet is set in motion.

In case, however, loud ringing bells are required, or bells in locations where telephones are not installed, it will be found more satisfactory to install this code signaling system independently of any other equipment.

**3. With Private Exchange or Private Branch Exchange Telephone Systems.** A mechanical signaling system, when installed in connection with telephone systems of this class, should be put in as a separate system without special regard for the location of the various telephone instruments, the object being rather to so locate the bells that they will be best heard from every nook and corner of the plant.

## MECHANICAL CODE SIGNALING SYSTEMS

### General—(Continued)

**CONNECTION DIAGRAMS.** No connection diagrams are given for the reason that there are many different signaling systems in which the code signaling sets can be used. We furnish, upon application, detail information covering the connection of these sets with inter-phones and with large and small bells and buzzers. If you will advise us as to your requirements, we will be very glad to work up a suitable signaling system and make you a quotation.

**REQUIREMENTS.** The following apparatus and accessories are usually required:

- The key cabinet (state capacity) with 4 (or less) up to 16 keys.
- Any number and size of bells.
- One resistance coil and condenser box (to prevent sparking at contacts).
- One or more relay boxes, depending upon the number and size of bells and the length and size of wire.
- Necessary wire to connect the apparatus.
- One or more batteries consisting of four or more cells, depending upon the number and size of bells and the length and size of wire.



No. 2A Code Signaling Set

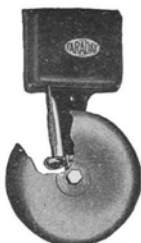

Model "ASS"  
Single-stroke Enclosed Type

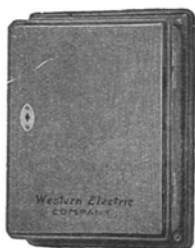

No. 262F  
Coil and Condenser Box  
Telephone Apparatus and Supplies

### Code Signaling Sets

The cabinets are made of golden oak, quarter-sawn. The metal face is finished in dull black with nickel trimmings. The sets are made only in 4 and 6 key sizes (each key providing a different signal), but they can be mounted side by side when 8, 10, 12, 14 or 16 signals are required.

Code No.	No. of Signals	Description	List Price Each
1A	4	Used for 4 signals	\$113.70
1B	4	Used with 1A for 8 signals	113.70
1C	4	Used with 2A for 10 signals	113.70
1E	4	Used with 1A and 1B for 12 signals	113.70
1F	4	Used with 2A and 1C for 14 signals	113.70
1D	4	Used with 1A, 1B and 1E for 16 signals	113.70
2A	6	Used for 6 signals	146.70
2B	6	Used with 1A for 10 signals	146.70
2C	6	Used with 2A for 12 signals	146.70
2E	6	Used with 1A and 1B for 14 signals	146.70
2D	6	Used with 2A and 1C for 16 signals	146.70

Each of the above key cabinets may be ordered partially equipped. Deduct for each key omitted, list \$11.30.

If a special signal is desired one set should be ordered equipped with signal wheel No. 17.

### Bells and Horns

#### BELLS

Bells of the enclosed type, either single stroke or vibrating, with 4, 6 or 8 inch gongs, can be furnished, the particular type and size depending on the local conditions.

#### HORNS

Factory signaling horns can be furnished when a signal of this type for extremely noisy places is necessary.

### Coil, Condenser and Relay Boxes

With each code signaling set a resistance coil and condenser box, No. 262F, is required to prevent excessive sparking at the contacts. This box is made of quarter-sawn oak to match the set.

A relay box is necessary under certain conditions, depending upon the number and size of bells and the length and size of wire. This box contains a resistance coil and a condenser in addition to the relay. It is similar in appearance to the No. 262F, and is known as the No. 262G Relay Box.

Code No.	Description	List Price Each
262F	Coil and condenser box. Used to prevent sparking at contacts	\$9.30
262G	Relay box	16.50

**MERCURY ARC RECTIFIERS**

(See rectifiers.)

**MESSAGE REGISTERS**

For Counting the Number of Connections Made by an Operator.  
Mount on Steel Mounting Plates



No. 5L

Code No.	Resistance Ohms	Operates on	Non-operates on	List Price Each
5C	490	20 volts	18.5 volts	\$6.50
5H	.27	1.4 amperes	1.25 amperes	6.10
5M	280	.036 amperes	.032 amperes	6.70

For Counting the Number of Effective Calls Made on a Telephone Line.  
Mounts on a Steel Mounting Plate

Code No.	Resistance, Ohms		Operates on	Non-operates on	List Price Each
	Inner Winding	Outer Winding			
5L	37.5	463	*25.5 volts	*23.9 volts	\$6.70

\*Applies with both windings in series.  
No. 10A (see counters page 77).

**MOUNTING PLATES**

The term "mounting plate" refers in general to a mild steel plate arranged for mounting relays, resistances, message registers or small retardation coils. Plates for mounting drops and signals are known as "drop mountings" and "signal mountings" respectively.

Whenever necessary the holes for terminals are equipped with hard rubber bushings to insulate the parts in circuit from the plate.

Certain mounting plates are equipped with dustproof covers which enclose the strips of relays. Such mounting plates are used with relays which are not equipped with individual covers.

The code number of the apparatus for which the mounting plate is to be arranged must be specified in the order.

The following are a few of our standard mounting plates; other sizes are furnished to meet conditions.



No. 600A Arranged for No. 118U Relays



No. 737A With 2 "A" Type Relays



No. 601C Arranged for No. 19 Type Resistances



No. 671C

**Relay Mounting Plates**

Code No.	Number per Strip	Centers Inches	Dimensions Inches		Thick-ness	List Price Each
			Length	Width		
600A	10	1 3/4	19	1 3/4	3/8	\$1.00
605B	34	1 5/8	21 5/8	4 1/4	3/8	3.10
606A	10	1 3/4	21 5/8	1 3/4	3/8	1.10
609A	10	1 3/4	23	1 3/4	3/8	1.10
†737A	20	3/4	19	1 3/4	3/4	3.10

**Resistance Mounting Plates**

601A	10	1 3/4	19	1 3/4	1/8	\$0.80
601C	40	1 5/8	19	1 3/4	1/8	1.10
602B	48	1 5/8	23	1 3/4	1/8	1.10
607B	46	1 5/8	21 5/8	1 3/4	1/8	1.30

**Message Register Mounting Plates**

*623B	20	1 5/8	33 3/4	11 1/4	3/8	\$2.30
†623C	20	1 5/8	33 3/4	11 1/4	3/8	2.70
†671B	10	1 5/8	19	1 1/4	3/8	1.50
*671C	10	1 5/8	19	1 1/4	3/8	1.80

\*Arranged to mount No. 5L message registers.

†Arranged to mount Nos. 5C, H and M message registers.

‡Equipped with dustproof cover.

NUMBER PLATES



No. 1A



No. 23C



No. 60D

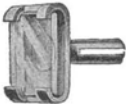

No. 30A



No. 128B

Code No.	Description	Size Inches	Used on	List Price Each
*1A	White ivory, black figures 1/4 in. high	5/8 diam.	Wooden stile casings and panel numbers.	\$0.14
*12A	White ivory, black figures 1/8 in. high.	3/8 diam.	Plug shelves and key shelves.	.14
*113A	White ivory, black figures 1/2 in. high.	1 1/4 diam.	Panels of switchboard.	.70
*23C	Aluminum, black figures 3/32 in. high.	3 1/2 diam.	Flat iron stile casings.	.14
*23D	Aluminum, black figures 1/32 in. high.	3 1/2 diam.	Flat iron stile casings.	.14
*107B	Aluminum, black figures 1/4 in. high.	3 1/2 diam.	Flat iron stile casings.	.14
*59B	Hard rubber face, white figures 1/32 in. high.	1 1/8 x 1 1/8	Nos. 2 and 117 jack mountings, No. 2C designation strip, Nos. 50A and 50B designation strips.	.14
*5B	Hard rubber, white figures, 1/32 in. high.	1 1/8 x 1/2	No. 110 jack mounting.	.14
*60D	Hard rubber, white figures 1/8 in. high.	1/4 x 3/8	No. 19 jack mounting.	.14
*21B	Hard rubber, white figures 1/32 in. high.	1 1/8 x 1 1/8	No. 105 board, for numbering toll and outgoing jacks.	.14
†30A	Metal, black finish, with celluloid covering for paper strip.	1/4 x 3/8	No. 19 jack mounting.	.07
†31A	Metal, black finish, with celluloid covering for paper strip.	1 1/8 x 1 1/8	Nos. 2 and 117 jack mountings and Nos. 2C, 50A and 50B designation strips.	.07
†108A	Metal, black finish, numbers printed on white paper.	1 1/4 x 3 1/2	No. 19 jack mounting and No. 134 lamp socket mounting when mounted together.	.07
†109A	Metal, black finish, numbers printed on white paper.	1 1/2 x 3 1/2	Nos. 2 or 117 jack mountings and No. 122 lamp socket mounting when mounted together.	.07

Code No.	Description	Size Inches	Used on	List Price per 100
124A	Brass, white celluloid cover.	1/4 diam.	No. 125 jack mounting as designation plugs to indicate different conditions of the line.	\$4.50
124B	Brass, red celluloid cover.			
124C	Brass, slate celluloid cover.			
124D	Brass, black celluloid cover.			
124E	Brass, yellow celluloid cover.			
124F	Brass, blue celluloid cover.			
124G	Brass, green celluloid cover.			
124H	Brass, light green celluloid cover.			

Code No.	Description	Size Inches	Used on	List Price Each
128A	Metal, nickel plated, paper card with celluloid covering.	2 3/4 x 1 1/4	Face of transmitters.	\$0.10
128B	Metal, black finish, paper card with celluloid covering.	2 3/4 x 1 1/4	Face of transmitters.	.10

\*Engraved as specified in order.

†Numbers from 0 to 9727 inclusive are furnished on printed sheets, 512 numbers to a sheet. Sheets desired must be specified in order.

**PLUGS**

If cords are desired, the Code No. and other necessary information (see cords) must be given in the order.  
No extra charge is made for attaching cords to plugs.



No. 47



No. 85



No. 109



No. 116



No. 124



No. 137



No. 146

Code No.	No. of Conductors	Used With Jacks Nos.	Used With Combined Jacks and Signals Nos.	Ordinarily Used With Cords Nos.	List Price Each
*47A } *47B }	2	{ 99, 147, 151, 152, 155, 156, 168, 172, 173, 174, 175, 176, 177, 188, 189, 204, 215, 216, 217, 218, 223.	{ 2, 3, 6, 7, 8, 22, 23, 26 and 27 types	{ 156, 421, 493, 556	{ \$0.80 .80
†85	3	77, 78, 190		29, 30	2.60
109	3	92		155, 386, 447	1.90
110	3	{ 49, 70, 141, 147, 159, 160, 161, 162, 163, 165, 178, 179, 180, 181, 182, 184	{ 4, 11, 12, 24, 31 types	{ 155, 387, 448, 518	1.90
116	1	{ 99, 146, 147, 151, 152, 155, 156, 167, 168, 172, 173, 174, 175, 176, 177, 188, 189, 215, 216, 217, 218, 225	9 type	{ 510, 513, 519	.40
†136	2	99, 152		369	.80
†137	Twin 2	{ 99, 152 on Nos. 30, 78 or 80 mountings		{ 87, 254, 558	2.50
145	2		42C	Special 493	1.40
146	2	186		509	9.50

\*Nos. 47A and B are the same except that the No. 47A has a red shell and the No. 47B has a black shell.  
†Nos. 85, 136 and 137 are used with operator's head telephones.

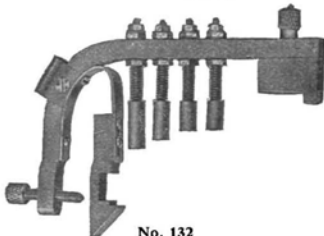

No. 132

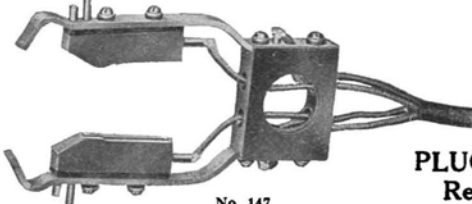

No. 147

**For Testing on Distributing Frames**

Code No.	No. of Conductors	Ordinarily Used With Cords Nos.	Used With	List Price Each
124	2	153, 555	Nos. 4, 65, 78, 84, 87, 89, 1168 and 1169 type protectors for testing.	\$1.80
132	4	129, 153, 556	Nos. 35, 36, 38 and 39 terminal strips for testing.	5.40
147	4	129, 555, 558	Nos. 4, 65, 78, 84, 89, 1168 and 1169 type protectors for testing.	3.20



No. 13 Plug Seat

Code No.	Mount on Centers, Inches
12	3/4
13	3/4
15	29/32

**PLUG SEATS  
Red Fiber**

Used With Plugs Nos.	List Price per 100
110	\$2.70
109	2.70
47,116	2.70

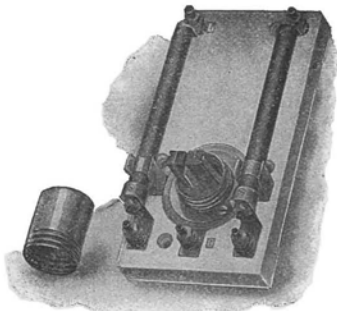

No. 12A Protector



No. 58A Protector



No. 60A Protector



No. 62A

Telephone Apparatus and Supplies

**POLE CHANGERS**

(See Interrupters)

**PROTECTORS**

**Mounted Singly**

**No. 12 Type**

Code No.	Equipped With	Protects	List Price Each
12A	2 No. 12A Fuses 2 No. 1 Protector Blocks 2 No. 2 Protector Blocks 2 No. 3 Protector Micas	Magneto telephone sets against high potential (lightning), abnormal and sneak currents.	\$2.00

**No. 58 Type**

58A	2 No. 11C Fuses 2 No. 1 Protector Blocks 2 No. 2 Protector Blocks 2 No. 3 Protector Micas	Central battery or magneto telephone sets against high potential (lightning) and abnormal currents.	1.30
58B	2 No. 11C Fuses 2 No. 19 Protector Blocks 2 No. 20 Protector Blocks 2 No. 10 Protector Micas	Magneto telephone sets against high potential (lightning) and abnormal currents.	1.60

**No. 60 Type**

60A	2 No. 1 Protector Blocks 2 No. 2 Protector Blocks 2 No. 3 Protector Micas	Central battery or magneto telephone sets against high potential currents (lightning).	.56
60B	2 No. 19 Protector Blocks 2 No. 20 Protector Blocks 2 No. 10 Protector Micas	Magneto or C.B. telephone sets against high potential currents (lightning).	.90

**No. 62 Type**

62C	1 No. 35A Fuse	Central battery switch-board circuits against abnormal currents.	.36
62D	1 No. 24A Fuse	Central battery switch-board circuits against abnormal currents.	.16

**PROTECTORS**

**Mounted Singly (Continued)**

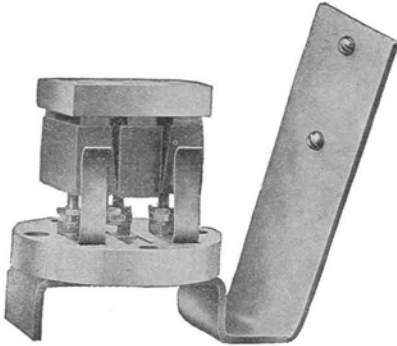

No. 86A Protector. Cover Removed

Code No.	Equipped with	Protects	List Price Each
86A	Porcelain base, carbon blocks and a sheet iron cover.	Telephone lines against high potential and abnormal currents.	\$3.30
86B	Porcelain base, carbon blocks and a cast iron cover.	Telephone lines against high potential and abnormal currents.	4.30
T-533B	Non-arcing metallic electrodes in a hermetically sealed case suitable for mounting out of doors.	Against high potential currents.	On request



No. T-533B Protector

**Metal Tube Vacuum Arresters**

List No.	Description	List Price Each
120274	Metal tube vacuum arresters (single pole) . . . . .	On request
120275	Metal tube vacuum arresters (double pole) . . . . .	On request

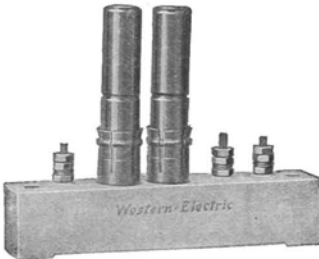

No. 120275 Metal Tube Vacuum Arrester

**No. 17 Type Protectors**

These are furnished only in lengths of one protector per strip.

Mount on No. 1075A protectors or on binding post strips on  $\frac{11}{16}$  inch centers.

Require the use of a No. 1 type ground strip which must be ordered separately.

For replacements or other places where No. 1 type ground strips are not suitable, ground strip P-100333 and connecting strip P-100332 will be furnished, but must be ordered separately. One ground strip and one connecting strip will equip two protectors.

Code No.	Equipped with	Protects	List Price Each
17A	2 No. 2 protector blocks 2 No. 5 protector blocks 2 No. 12 protector micas	Against high potential currents.	On request
17B	2 No. 19 protector blocks 2 No. 20 protector blocks 2 No. 11 protector micas	Against high potential currents.	\$1.00

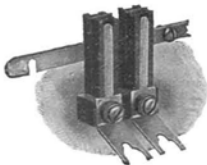

No. 17A with Connector and Section of Ground Strip

**Ground Strips No. 1 Type**

Code No.	Will Mount	Length	List Price Each
1A	13 No. 17 type protectors	1 ft. $7\frac{1}{2}$ ins.	\$1.50
1B	16 No. 17 type protectors	1 ft. $11\frac{1}{2}$ ins.	1.70
1C	26 No. 17 type protectors	3 ft. $1\frac{1}{2}$ ins.	2.40

Connector P-100332 will be furnished, when required, for connecting two ground strips together, but must be ordered separately.

**PROTECTORS**

**Mounted in Strips**

In ordering, specify the number of protectors per strip (noting that some protectors are single while others are in pairs), and if the protector is for a frame give sufficient information for the drilling. If the protector is to be mounted on a frame which we have furnished and installed, the name of the exchange with the location of the protectors on the frame is sufficient.

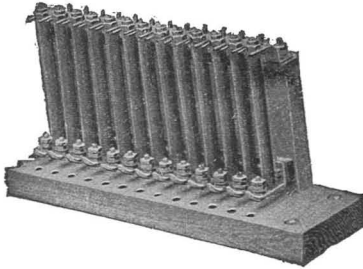

No. 7D

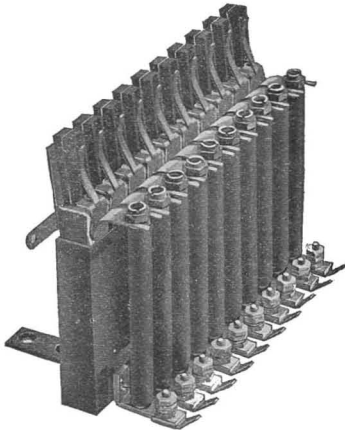

No. 61B

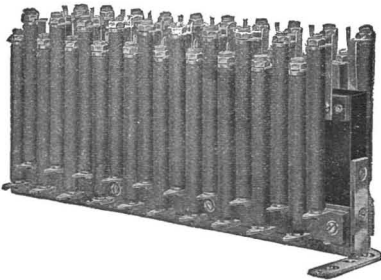

No. 77B

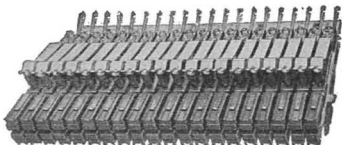

20 No. 1169A

Telephone Apparatus and Supplies

Code No.	Equipped with	Protects	List Price Each
7D	1 No. 7A Fuse	Magneto and central battery exchanges against abnormal currents.	\$0.48
61B	1 No. 7A fuse 1 No. 19 protector block 1 No. 20 protector block 1 No. 11 protector mica	Magneto and central battery exchanges against high potentials and abnormal currents. Used in cable terminals.	.94
77B	1 No. 7A fuse	Against abnormal currents. Used in cable terminals.	.40
1075A	1 No. 7A fuse	Against abnormal currents. Used in cable terminals.	.44

**Unit Type**

The Nos. 1168A and B protectors are alike except for the mounting; the No. 1169A differs from the No. 1168A only in the way the wires are connected to them. The No. 1169A is designed for the outside wires to be connected first to a terminal block and jumper wires to extend from the terminal block to one side of the protector and the switchboard cables to the other. The Nos. 1168A and B are just the reverse, that is, they are designed for the outside wires to be connected directly to one side of the protector, and jumper wires to extend from the other side to a terminal strip, where they are connected to the switchboard cable.

Code No.	Equipped with	Protects	List Price Each
*1168A	2 No. 67 heat coils 2 No. 1 protector blocks 2 No. 2 protector blocks 2 No. 3 protector micas	Central battery and magneto exchanges against high potential and sneak currents.	\$1.10
†1168B	2 No. 67 heat coils 2 No. 1 protector blocks 2 No. 2 protector blocks 2 No. 3 protector micas	Central battery and magneto exchanges against high potentials and sneak currents.	1.10
*1169A	2 No. 67 heat coils 2 No. 1 protector blocks 2 No. 2 protector blocks 2 No. 3 protector micas	Central battery and magneto exchanges against high potential and sneak currents.	1.10

\*Furnished only in lengths of 20 protectors per strip.

†Furnished only in lengths of 23 protectors per strip.

PROTECTOR CABINETS

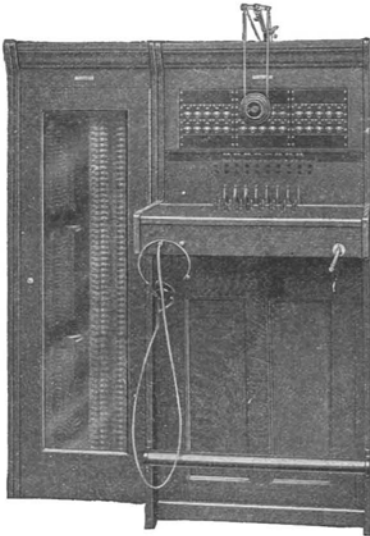

These protector cabinets are designed to accommodate protective and terminal equipment for small central offices where the entire exchange equipment is placed in one room, and where an iron rack or distributing frame would be objectionable in appearance.

They are constructed of first quality oak and given a highly polished, rich golden oak finish to match our standard switchboard woodwork. The front door has a large glass panel or window and is hinged by means of a "piano hinge." The rear door is removable. The end panel may be used on either end. The protectors and the terminal equipment used are furnished in groups of twenty lines each and are mounted in the cabinet on a rigid steel frame accessibly located. These groups are indicated in the following table and are listed and described under the heading of "Protector Groups."

When several of these cabinets or units are placed together they give the appearance of one continuous cabinet both inside and out.

Code No.	Switchboard With Which It Lines Up	Protector Groups Used		Line Capacity	List Price Each
		Inside Lines	Outside Lines		
1411A	1220-1239	1435P	1435J or K	120	\$84.90
1412A	1240-1259	1435P	1435J or K	120	95.00
1411B	Same as No. 1411A except end panel omitted . . . . .				71.40
1412B	Same as No. 1412A except end panel omitted . . . . .				81.40

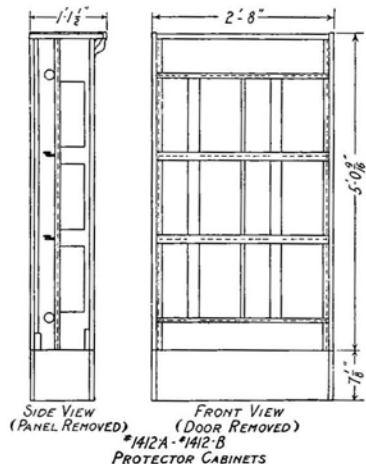
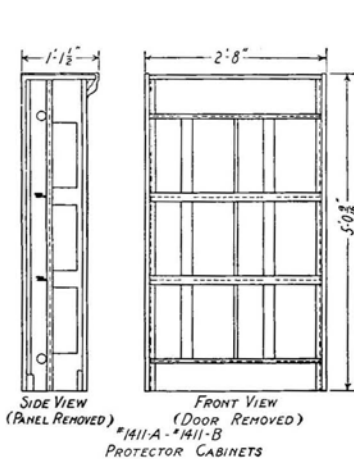

## PROTECTOR GROUPS

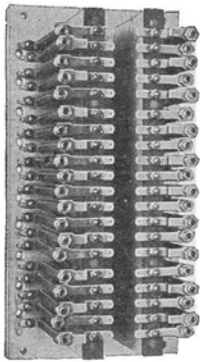

No. 1435J



No. 1435R

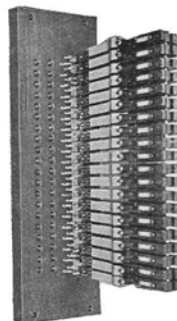

No. 1435P

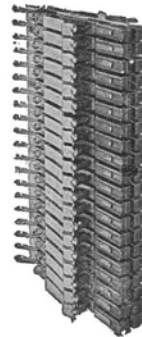

No. 1435T

These protector groups may be used for either central battery or magneto telephone lines and are intended to mount on the various types of distributing frames and cabinets listed elsewhere in this catalog.

They consist of a mounting of proper size, for attaching to the frame, on which the protector apparatus as listed below is assembled.

Code No.	Protects	Consists of	Used With Distributing Frame No.	List Price Each
<b>No. 1435J</b>				
1435J	20 metallic outside lines against abnormal current.	20 protectors equipped with No. 7A fuses and mounted on a base which serves as a fanning strip.	1420B 1430D, E, F 1431A	\$17.00
<b>No. 1435R</b>				
1435R	25 metallic outside lines where fuse protection is unnecessary.	A terminal strip mounted on a base which serves as a fanning strip.	1420B 1430D, E, F 1431A	2.90
<b>No. 1435P</b>				
1435P	20 metallic inside lines against high potential and sneak currents.	20 No. 1169A protectors mounted on a base which serves as a fanning strip.	1420B 1430D, E, F 1431A	23.00
<b>No. 1435T</b>				
1435T	20 metallic inside lines against high potential and sneak currents.	20 No. 1169A protectors	1425C	23.00
Telephone Apparatus and Supplies		136		

**PROTECTOR BLOCKS**



No. 1



No. 2



No. 19



No. 20



No. 3



No. 10



No. 48



No. 1006A  
Push Button

Code No.	Description	Used With			List Price per 100
		Protector Blocks	Protector Micras	Protectors	
1	Plain carbon block with fuse metal.	No. 2	Nos. 3 and 12	Nos. 4A, 4C, 12A, 58A, 60A, 65A, 65B, 78A, 78B, 79A, 84A, 84B, 1168A, 1168B, 1169A.	\$1.90
2	Grooved carbon block without fuse metal.	Nos. 1 and 5	Nos. 3 and 12	Nos. 4A, 4C, 12A, 17A, 58A, 60A, 65A, 65B, 78A, 78B, 79A, 84A, 84B, 1168A, 1168B, 1169A.	1.00 On request
5	Grooved carbon block with fuse metal.	No. 2	Nos. 3 and 12	No. 17A	1.00 On request
9	Paraffined wood dummy.			Nos. 4, 65, 78, 84, 1168, 1169 types.	.80
19	Plain copper block with two pins.	No. 20	Nos. 10 and 11	Nos. 17B, 58B, 58C, 60B, 61B, 79A, 80A.	8.60
20	Grooved copper block with two bushings.	No. 19	Nos. 10 and 11	Nos. 17B, 58B, 58C, 60B, 61B, 79A, 80A.	9.00
25	Plain copper block with two pins and fuse metal.			In place of the No. 19 protector block where a copper block with fuse metal is desired.	19.50

**PROTECTOR MICAS**

Code No.	Protector Blocks	Used With		List Price per 100
		Protectors		
3	Nos. 1 and 2	Nos. 4A, 4C, 12A, 17A, 58A, 60A, 65A, 65B, 78A, 78B, 79A, 84A, 84B, 1168A, 1168B, 1169A		\$5.90
10	Nos. 19, 20 and 21	Nos. 17B, 58B, 58C, 60B, 60E, 61B, 79A, 80A		7.80
11	Nos. 19 and 20	Nos. 17B, 58B, 58C, 60B, 61B, 79A, 80A		11.70
12	Nos. 2 and 5	No. 17A		On request

**PROTECTOR MOUNTINGS**

Code No.	Description	List Price Each
48	Asbestos mat, 8 x 4 $\frac{3}{8}$ x $\frac{3}{8}$ ins. for use with No. 58 type protectors.	\$0.045
<b>Protector Mounting Plates</b>		
736A	A supporting bar 1 $\frac{1}{2}$ ins. wide by $\frac{1}{4}$ in. thick, equipped with angle brackets. Adapted to fasten to cross strips on the wall. Furnished in various lengths suitable for mounting No. 1168 and No. 1169 type protectors. Number of protectors per mounting (maximum 243) must be specified in order.	On request

**PUSH BUTTONS**

Code No.	Description	List Price Each
1006A	These are intended for use in magneto telephones arranged for "central office selective signaling." Makes one and breaks one contact when operated.	\$0.60
1002A	Same as No. 1006A except makes two and breaks one contact when operated.	.80
1004A	Intended for use in magneto telephones arranged for "signaling central secretly." Makes two and breaks two contacts when operated. Similar to No. 1006A except for spring combination.	1.10

RECEIVERS



No. 128W

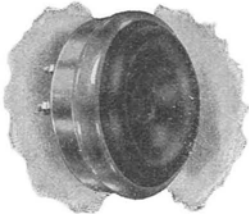

No. 131W

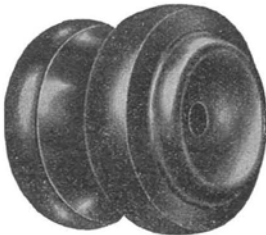

No. 133W

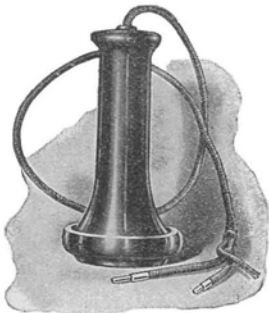

Nos. 143AW and 144AW  
Equipped With Cord  
Telephone Apparatus and Supplies

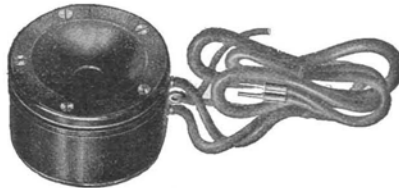

No. 125W

Code No.	Description	Used	List Price Each
125W	Lineman's bipolar receiver, hard rubber case with metal back. Includes 3 ft. No. 15 cord. Approximate resistance 90 ohms.	No. 1006 type test sets.	\$6.70
128W	Standard bipolar head receiver, hard rubber case. Approximate resistance 70 ohms.	Operator's telephone set; all switchboards.	3.70
131W	Bipolar receiver, metal case with hard rubber ear piece. Approximate resistance 70 ohms.	With No. 1001 type hand sets.	4.50
133W	Insulated bipolar hand receiver with hard rubber case. Approximate resistance 70 ohms.	With No. 1314A telephone	4.40
141W	Small, bipolar receiver, metal case with composition ear piece. Approximate resistance 70 ohms.	No. 1002 type hand sets	3.70
143AW	Concealed binding post bipolar hand receiver. Composition case. Approximate resistance 75 ohms.	Telephones, desk stands, telephone arms, etc.	2.30
144AW	*Same as No. 143AW, excepting the case is hard rubber. Approximate resistance 75 ohms.	Telephones, desk stands, telephone arms, etc.	2.80
145W	Bipolar watch case type receiver, hard rubber case. Approximate resistance 70 ohms.	With No. 1017 type test sets and in combination with head band equipment to form other receivers.	2.70
146W	Small, bipolar receiver, hard rubber case. Approximate resistance 610 ohms.	Auxiliary receiver for desk stands.	3.40

**\*Note:** Special attention is called to the wearing qualities and strength of the hard rubber shell and cap of the No. 144 type receiver. Receivers with shells of special composition and with shells of reinforced composition are being marketed, but none excel our No. 144 receiver in ability to withstand severe treatment and sudden changes in temperature, as well as in retaining their permanency of finish and luster.

RECEIVERS



No. 147W



No. 153W  
No. 164W



No. 148W  
No. 156W



Nos. 163W and 171W  
Equipped with Cord

Code No.	Description and Use	List Price Each
147W	Bipolar double head receiver consisting of two No. 145W receivers equipped with adjustable ball and socket joints and a two-piece nickel-plated head band. Approximate resistance 70 ohms per unit.  With No. 283W transmitter and No. 363 cord in dispatcher's telephone set.....	\$11.30
145W	Bipolar single head receiver, similar to the No. 145W receiver except equipped with a leather covered head band. Approximate resistance 70 ohms.  With No. 283W transmitter and a No. 375 cord in dispatcher's head telephone set.....	5.20
153W	Bipolar double head receiver similar to No. 147W, but equipped with a two-piece hard rubber covered head band. Approximate resistance 70 ohms per unit.  With No. 283W transmitter and a No. 363 cord in dispatcher's telephone set.....	13.50
156W	Bipolar single head receiver, hard rubber case. Equipped with leather covered head band. Approximate resistance 610 ohms.  With Nos. 1020AB desk stands, 1020C, and 1048DA, DB, DC, DD, GA, GB, GC and GD telephone arms, 1317AE, AW and 1293AE, AL telephone sets.....	5.60
163W	A concealed binding post bipolar hand receiver having a hard rubber case. Approximate resistance 500 ohms. Similar in appearance to No. 143AW and 144AW.  With the Nos. 1317W, AD, and 1293AD, AK telephone sets.....	4.40
164W	Bipolar double head receiver similar to No. 153W, but consists of one 610 ohm and one 70 ohm unit.  With No. 283W transmitter and No. 363 or 371 cords in dispatcher's set.....	12.40
171W	Concealed binding post bipolar hand receiver. Has no permanent magnet. Composition case. Approximate resistance 76 ohms.  Series central battery telephones.....	2.00

RECEIVER PARTS

Part	No. 143AW	No. 144AW	No. 128W	No. 156W
Shell.....	P-93518	P-94533	.....	.....
Earpiece.....	P-93519	P-93520	P-90472	P-91078
Diaphragm.....	P-95114	P-95114	P-95225	P-95225
Head band.....	.....	.....	P-95226	P-92808

MERCURY ARC RECTIFIERS

Type "AT"

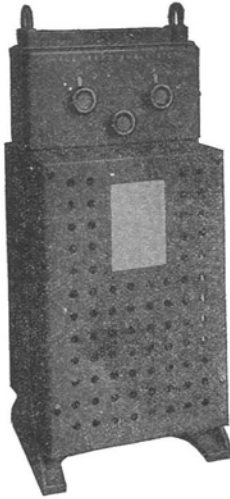

Type AT Rectifier, Cover On

Mercury Arc Rectifiers are used in telephone exchanges to change alternating current into the direct current required to charge storage batteries.

The Type AT rectifier outfit has been designed especially for telephone work in that precautions have been taken to eliminate noise (due to the use of alternating current) and to insulate the battery circuit from the supply circuits so that disturbances due to grounds on the latter will be avoided. A damping coil is used to decrease the noise while the batteries are being charged. To insulate the battery from the supply circuit, a two-winding transformer is used instead of an auto-transformer.

Regulating dials are provided giving fifteen (15) points of adjustment so that the rate of charge can be adjusted and kept practically constant for any setting of the dials. The rectifier is neither self-starting nor self-stopping.

Link connections are provided for adapting the outfits to either 110 or 220 volt circuits.

The Type AT outfits are designed for charging one particular number of cells, either 11 or 17 cells in series. The dial switch steps are suitably proportioned. Any one outfit can be adapted for charging either 11 or 17 cells by means of link connections. The dial steps, however, are especially proportioned for the number of cells that the outfit was primarily designed to serve.

RECTIFIER OUTFITS FOR 60 CYCLE CIRCUITS

List No.	No. of Cells	—Direct Current Output—		A.C. Volts Input
		Amperes	Volts	
220241	11 and 17	10	20 to 55	110 or 220
220242	17 and 11	10	20 to 55	110 or 220
220243	11 and 17	20	20 to 55	110 or 220
220244	17 and 11	20	20 to 55	110 or 220
220245	11 and 17	30	20 to 55	110 or 220
220246	17 and 11	30	20 to 55	110 or 220
220247	11 and 17	40	20 to 55	110 or 220
220248	17 and 11	40	20 to 55	110 or 220
220249	11 and 17	50	20 to 55	110 or 220
220250	17 and 11	50	20 to 55	110 or 220

The outfits are furnished complete, with one bulb. Prices upon application.

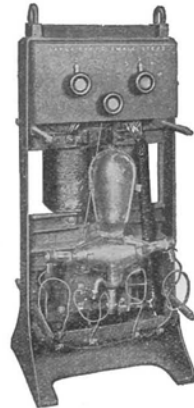

Type AT Rectifier Cover Off

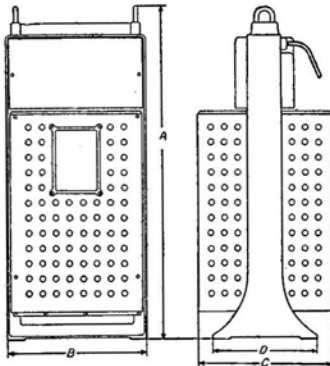

DIMENSIONS AND WEIGHT

Code No.	—Dimensions in Inches—				Approx. Wt. in Lbs.	
	A	B	C	D	Net	Boxed
220243	44 <sup>7</sup> / <sub>16</sub>	18 <sup>3</sup> / <sub>4</sub>	20 <sup>5</sup> / <sub>8</sub>	16	565	675
220244					565	675
220245					435	535
220246					435	535
220247	56	21 <sup>1</sup> / <sub>8</sub>	21 <sup>3</sup> / <sub>4</sub>	18	775	975
220248					775	975
220249					650	850
220250					650	850

## RELAYS

The wide range of types and resistances of our relays make it impracticable to catalog them all here. The following will convey an idea of the types in general. The resistances of the windings and the arrangements of contacts are varied to meet the requirements of the circuits in which they are placed.



No. 44 Type

**No. 44 Type**

**No. 44 Type** is self-restoring and has the characteristics of a drop. Has a line operating coil and a restoring coil. Used when a local signal circuit is to be closed by ringing on the line. When the line coil is energized, the front armature is released and falls forward, closing a local contact. When the restoring coil is energized, the front armature is restored to the vertical position. Has a cross-talk proof shell. Makes one contact when operated.

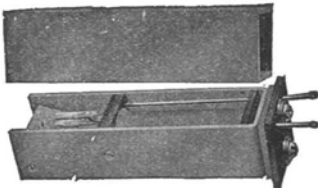

No. 87 Type

**No. 87 Type**

**No. 87 Type** closes a local circuit only while the line is being rung upon. Has flexible contact springs and a heavy armature of sluggish action so that the local circuit remains closed as long as there is ringing current on the line. Used in trunk circuits between central offices. Has a cross-talk proof cover. Makes one contact when operated. One type has an independent breaking contact.

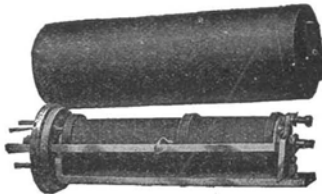

No. 89 Type

**No. 89 Type**

**No. 89 Type** has an operating coil and a locking coil. Made to respond to ringing current and to close a circuit through its armature contact and locking coil so that the relay remains in the operated position after ringing has ceased. Used for toll line signaling and in toll cord supervisory circuits. Has cross-talk proof cover. Makes one contact when operated.

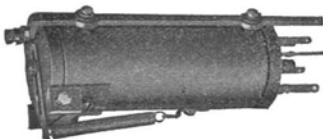

No. 114 Type

**No. 114 Type**

**No. 114 Type** operates on direct current. Has one or two operating windings. Used when a firmly established back contact is desired. Has cross-talk proof shell. Makes one contact and breaks one.



No. 118 Type

**No. 118 Type**

**No. 118 Type.** Sensitive relay for operating on direct current. For general use where a single contact is to be made. Has cross-talk proof cover. One form of this relay has in addition a back contact.

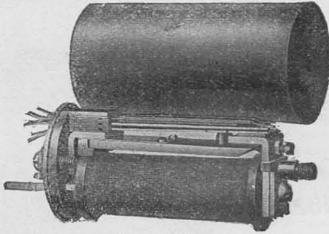

No. 122 Type

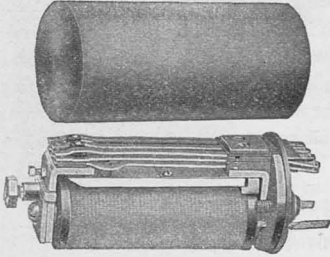

No. 125 Type



No. 189 Type

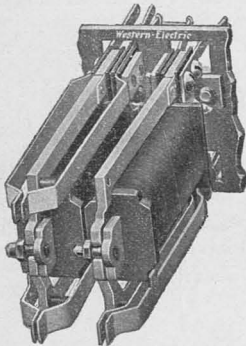

No. 194 Type

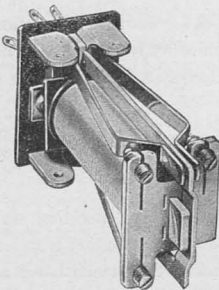
"B" Type, Cover Removed  
Telephone Apparatus and Supplies

## RELAYS

### No. 122 Type

**No. 122 Type**—Operated by direct current and generally used where it is desired to break two and then make two contacts, or to make two and then break two contacts, when the relay is energized. Has dust-proof cover.

### No. 125 Type

**No. 125 Type**—Operated by direct current and generally used where it is desired to break three and then make three contacts, or to make three and then break three contacts, when the relay is energized. Has dust-proof cover.

### No. 189 Type

**No. 189 Type**—A small relay operating on direct current. Used as a line relay with the No. 10 switchboard. Makes one contact when operated.

### No. 194 Type

**No. 194 Type**—This compact type line and cut-off relay is used with the No. 1 type switchboard; comprises an "A" type line relay which controls the signal lamp circuit, and an "A" type cut-off relay which operates and cuts off the line relay and signal equipment when the call is answered.

### "A" Type

**"A" Type**—Flat type relays of punched construction. Intended to mount on mounting plates provided with dust-proof covers. Will mount on  $\frac{3}{4}$  inch horizontal and  $1\frac{3}{4}$  inch (including cover) vertical centers.

### "B" Type

**"B" Type**—Flat type relays with micrometer screw adjustment. Used where a relay with sensitive adjustment is required. Has a dust-proof cover with a removable cap. The adjustment of the relay can be easily changed with an ordinary screwdriver by merely removing the cap from the end of the dust-proof cover.

## REPEATING COILS

The Nos. 20A and 30A have a cloth covering. With these exceptions the coils listed below are enclosed in iron cross-talk proof shells. The No. 25E is provided with a hard rubber base. All others are mounted on wooden bases.

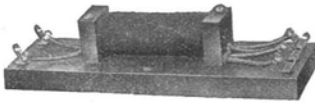

No. 20A



No. 25E



No. 30A

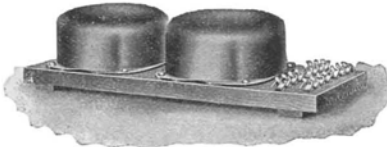

No. 25A

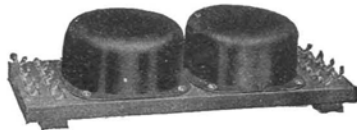

No. 25C



No. 26A

Code No.	Resistance Ohms	Size of Base Inches	Use	List Price Each
20A	1 primary winding, 277. 1 secondary winding, 40. 1 tertiary winding, non-inductive, 360.	$5\frac{1}{8} \times 1\frac{1}{4}$	Operator's telephone circuit, No. 1 switch-board for busy test.	\$2.00
25E	1 primary winding, 42. 1 secondary winding, 42.	$3\frac{3}{8} \times 4\frac{7}{8}$	Street railway telephone sets Nos. 1278 and 1302 types.	8.10
30A	1 primary winding, 385. 1 secondary winding, .01.	$5\frac{1}{2} \times 5\frac{1}{2}$	Tone test circuit.	11.30

### No. 25 Type

These have two coils mounted on one base and are for use on standard repeating coil racks. Size of base is  $10\frac{3}{4}$  inches by 4 inches.

The windings of the Nos. 25C and 25G are the same as those of the Nos. 25A and 25S respectively, except that they are brought out to terminals on both ends of the base.

Code No.	Resistance Ohms	Used With	List Price Each
25A	2 primary windings, 21 each. 2 secondary windings, 21 each.	Cord circuits and incoming trunk circuits on central battery switchboards.	\$12.40
25S	2 primary windings, 21 each. 2 secondary windings, 21 each. 2 non-inductive windings, 40 each.	48 volts battery long distance and incoming toll trunks, central battery switchboards.	13.50
25C	2 primary windings, 21 each. 2 secondary windings, 21 each.	Cord circuit and incoming trunk circuits on central battery switchboards.	12.40
25G	2 primary windings, 21 each. 2 secondary windings, 21 each. 2 non-inductive windings, 40 each.	48 volt battery long distance and incoming toll trunks, central battery switchboards.	13.50

### No. 26 Type

These have one coil per base, and are for use on standard repeating coil racks. Size of base is  $10\frac{3}{4} \times 4$  inches.

The windings of the No. 26C are the same as those of the No. 26A, except that they are brought out to terminals on both ends of the base.

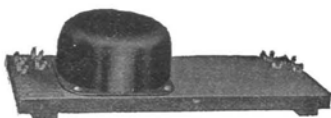

No. 26C

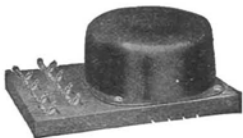

No. 27A



No. 42A

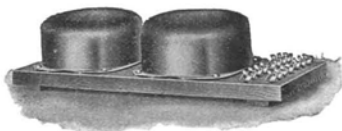

No. 46A



No. 47A

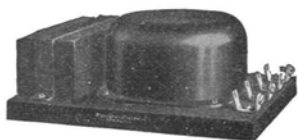

No. 1A Repeating Coil Group  
Telephone Apparatus and Supplies

## REPEATING COILS

### No. 26 Type (Continued)

Code No.	Resistance Ohms	Use	List Price Each
26A	2 primary windings, 21 each. 2 secondary windings, 21 each.	Cord circuits and incoming trunk circuits of central battery switchboards.	\$6.70
26H	2 primary windings, 21 each. 2 secondary windings, 21 each. 2 non-inductive windings, 40 each.	48 volt battery long distance and incoming toll trunks, central battery switchboards.	7.10
26C	2 primary windings, 21 each. 2 secondary windings, 21 each.	Cord circuits and incoming trunk circuits of central battery switchboards.	6.70

### No. 27 Type

These have a single coil on a base 6 x 4 inches and are used where a single coil mounted on a short base is desired.

27A	2 primary windings, 21 each. 2 secondary windings, 21 each.	Cord circuits and incoming trunk circuits on central battery switchboards.	\$6.50
27D	2 primary windings, 21 each. 2 secondary windings, 21 each. 2 non-inductive windings, 40 each.	48 volt battery long distance and incoming toll trunks on central battery switchboards.	6.80

### No. 42 Type

Diameter of shell, 1 3/8 inches; overall lengths, 42A, 2 1/4 inches, 42B, 4 1/8 inches.

42A	4 windings, 35, 53, 72 and 90.	Magneto cord circuits to prevent ringing through.	\$3.70
42B	4 windings, 22, 34, 45 and 57.	Magneto cord circuits to prevent ringing through.	4.40

### No. 46A

Has two coils mounted on one base and is for use on standard repeating coil racks. Size of base is 10 3/4 x 4 inches.

46A	2 primary windings, 21 each. 2 secondary windings 21 each.	Phantom and Simplex circuits.	\$15.80
-----	---	-------------------------------	---------

### No. 47A

Has a single coil on a base 6 x 4 inches and is used where a single coil mounted on a short base is desired.

47A	2 primary windings, 21 each. 2 secondary windings, 21 each.	Phantom and Simplex circuits.	\$9.80
-----	--	-------------------------------	--------

## REPEATING COIL GROUPS

1A	Consists of a No. 44A repeating coil and a No. 21L, two microfarads, condenser mounted on a wooden base 6 3/4 x 5 1/8 ins. The repeating coil has three inductive windings—two of 21 ohms each and one of 42 ohms. Used in cord circuits of No. 1800 type switchboards.	\$10.10
----	---	---------

## RESISTANCES

## No. 1 Type

These have one winding on a brass core, fiber heads, and inclosed in a brass shell.

Approximate dimensions: diameter  $\frac{1}{2}$  inch, overall length  $1\frac{1}{4}$  inches.



No. 1

Code No.	Resistance Ohms	List Price Each	Code No.	Resistance Ohms	List Price Each
1A	400	\$0.50	1K	30	\$0.50
1B	2500	.80	1L	100 (non-inductive)	.50
1C	500	.50	1N	700	.50
1D	60	.50	1P	5	.50
1E	300	.50	1R	250	.50
1F	1000	.80	1T	350	.50
1G	3000	1.00	1U	45	.50
1H	200	.50	1W	2000 (non-inductive)	.80
1J	20	.50	1Y	1200	.80

## No. 5 Type

These have one winding on a wooden spool.

Approximate dimensions: diameter  $1\frac{1}{8}$  inches; overall length 3 inches.



No. 5

Code No.	Resistance (Ohms)	List Price Each
5G	10000	\$2.50
5J	600	1.40
5K	750	1.90
5M	2500	1.90
5R	40	1.10
5AB	9250	2.50
5AC	2000	1.90
5AG	200	1.10
5AJ	15000	2.90

## No. 18 Type

These have one winding on a micanite core.

Approximate overall dimensions: width  $1\frac{1}{8}$  inches; thickness  $\frac{3}{8}$  inch; length  $4\frac{1}{2}$  inches.



No. 18

Code No.	Resistance Ohms	List Price Each	Code No.	Resistance Ohms	List Price Each
18A	37	\$0.52	18U	100	\$0.52
18B	40	.52	18W	133	.52
18C	83	.52	18Y	90	.52
18D	120	.52	18Z	67	.52
18E	140	.52	18AA	95	.52
18F	150	.52	18AB	45	.52
18G	200	.52	18AC	500	.52
18H	210	.52	18AD	240	.52
18J	30	.52	18AE	600	.52
18K	80	.52	18AF	300	.52
18L	170	.52	18AG	226	.52
18M	53	.52	18AH	320	.52
18N	180	.52	18AJ	400	.52
18P	130	.52	18AK	60	.52
18Q	110	.52	18AL	4	.52
18R	10	.52	18AM	250	.52
18S	20	.52	18AN	350	.52
18T	50	.52	18AP	500	.52

**RESISTANCES**

**No. 19 Type**

These have a micanite core, two windings and three terminals, the middle terminal being common to one end of each of the windings.

Approximate overall dimensions: Width  $1\frac{1}{8}$  inches; thickness  $\frac{3}{8}$  inch; length  $4\frac{3}{4}$  inches.



No. 19 Type Resistance

Code No.	Resistance Ohms	List Price Each	Code No.	Resistance Ohms	List Price Each
19A	37 and 37	\$0.56	19Z	120 and 120	\$0.56
19B	40 and 40	.56	19AA	15 and 90	.56
19C	40 and 83	.56	19AB	120 and 210	.56
19D	83 and 83	.56	19AC	60 and 83	.56
19E	30 and 30	.56	19AD	150 and 150	.56
19F	40 and 60	.56	19AF	140 and 140	.56
19G	40 and 100	.56	19AG	120 and 160	.56
19H	40 and 120	.56	19AH	240 and 240	.56
19J	10 and 40	.56	19AJ	200 and 200	.56
19K	100 and 100	.56	19AK	70 and 70	.56
19L	60 and 60	.56	19AL	40 and 68	.56
19M	20 and 20	.56	19AM	50 and 50	.56
19N	5 and 8	.56	19AN	260 and 260	.56
19P	20 and 130	.56	19AP	180 and 180	.56
19S	60 and 90	.56	19AR	60 and 260	.56
19T	25 and 25	.56	19AS	170 and 170	.56
19W	10 and 10	.56	19AU	60 and 170	.56
19Y	15 and 15	.56	19AW	2.5 and 2.5	.56

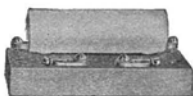

No. 31A Resistance

**No. 31 Type**

A steel tube enameled resistance; mounted on a wood base; use l in railway composite circuits.

Approximate dimensions: Length 4 inches; width 2 inches; overall height  $1\frac{3}{4}$  inches.



No. 31A Resistance

Code No.	Resistance Ohms	List Price Each
31A	1200	\$1.90

**No. 34 Type**

These have a brass core with one variable resistance winding brought out to several terminals. Front spool head is fiber. Used in train dispatching circuits.

Approximate dimensions: Diameter  $2\frac{1}{8}$  inches; overall length  $2\frac{3}{4}$  inches.

Code No.	Resistance Ohms	No. of Terminals	List Price Each
34A	200 to 30000 in steps of 200	9	\$1.40
34B	100 to 3100 in steps of 100	6	3.70
34C	4 to 3124 in steps of 4 up to 124	9	4.70

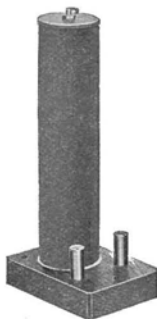

No. 34A Resistance

**No. 35 Type**

A resistance tube mounted on a wood base; used in train dispatching circuits.

Approximate dimensions: Length  $3\frac{1}{2}$  inches; width  $2\frac{1}{2}$  inches; height  $7\frac{7}{8}$  inches.

Code No.	Resistance Ohms	List Price Each
35D	250	\$1.90

No. 35D Resistance

**RESISTANCE LAMPS**

These have tubular bulbs  $1\frac{1}{4}$  inches diameter and  $4\frac{3}{4}$  inches long fitted with carbon filament and Edison bases.



No. 1 Resistance Lamp  
Telephone Apparatus and Supplies

Code No.	Resistance Ohms	List Price Each
1A	660	\$0.72
1B	220	.64
1C	300	.72
1D	100	.72
1E	440	.64

RETARDATION COILS

No. 5 Type



No. 5AC

Code No.	No. of Windings	Resistance (Ohms)	Use	List Price Each
5AC	4	384 (total)	Simplexing telephone lines and phantoming rural circuits.	\$14.90
5AD	2	25 (each)	Nos. 51A, 52A and 53A selector apparatus cases.	23.20

No. 8 Type



No. 8M

8B	2	85 (each)	Battery supply of P.B.X. cord circuits. Similar to No. 8C except without base.	\$5.40
8C	2	85 (each)	Battery supply of P.B.X. cord circuits mounted on a wooden base.	6.50
8K	2	35 (each)	Battery supply of P.B.X. cord circuits.	5.40
8L	2	175 (each)	Battery supply of P.B.X. cord circuits.	6.80
8M	2	165 (each)	Battery supply of P.B.X. cord circuits.	7.00
8N	2	85 (each)	Battery supply of P.B.X. cord circuits. No. 8B provided with mounting lugs.	5.40
8P	2	175 (each)	Battery supply of P.B.X. cord circuits. No. 8L provided with mounting lugs.	6.30

No. 12 Type



No. 12A

12A	1	165	Operator's telephone circuit in Nos. 1, 9 and 10 switchboards and Nos. 101 and 102 private exchanges.	\$1.40
12G	1	2.3	Nos. 1312A and 6023A telephone sets. Has a movable core for varying impedance.	1.30
12H	1	400	Primary circuit of battery driven ringing machine to choke out noises from the battery. The H, J and K are used with 1/2, 1 and 2 ampere 75 volt ringing machines respectively.	\$11.30
12J	1			11.30
12K	1			11.30
12L	1	400	Operator's telephone circuit, No. 4 private exchange.	2.50
12M	1	2.3	Nos. 1314A and E telephone sets.	1.30
12S	1	100	Operator's telephone circuit in No. 550 private exchange.	On request



Nos. 12H, J and K

No. 44 Type

44B	2 on each coil	203 each winding	Toll cord circuits. Have two separate toroidal type coils on a common wooden base.	\$27.80
44D	2 on each coil	83 each winding		

No. 46 Type



No. 46B

46A	1	600	For general use in switchboard circuits	\$1.70
46B	1	150		1.40
46C	1	200		1.60
46D	1	250		1.60
46E	1	300		1.70
46F	1	500		1.60
46G	1	750		1.70
46H	1	350		1.70
46J	1	900		1.70
46K	1	1000		1.80
46L	1	400		1.60
46M	2	125 (each)		1.90
46N	2	100 (each)		1.80
46P	2	500 (each)		1.80
46R	1	1500		1.60
46S	1	40		1.60
46T	2	33 (each)		1.40
46W	2	200 (each)		2.20
46Y	2	1000 (each)	2.50	



Nos. 46M, N, P, T, W and Y

RETARDATION COILS

No. 47 Type

Code No.	No. of Windings	Resistance Ohms	Use	List Price Each
47A	1	600	Differs from the No. 46 type only in that they are arranged to mount on mounting plates the same as relays, the terminals projecting through the plate.....	\$1.70
47B	1	150		1.40
47C	1	200		1.60
47D	1	250		1.60
47E	1	300		1.70
47F	1	500		1.60
47G	1	750		1.70
47H	1	350		1.70
47K	1	1000		1.80
47L	1	400		1.60
47M	2	125 (each)		1.90
47N	2	100 (each)		1.80
47P	2	500 (each)		1.80
47R	1	1500		1.60
47S	1	40	1.60	
47Y	2	1000 (each)	2.50	



No. 51C

No. 48 Type

48A	2 in series	100 (total)	Grounded composite circuits.	\$10.40
-----	-------------	-------------	------------------------------	---------

No. 49 Type

49A	4	37 (inside) 46 (outside)	Telephone lines in proximity to high power transmission lines. Designed to remove electrostatic and electromagnetic charges from the telephone lines.....	\$49.50
-----	---	-----------------------------	---	---------

No. 51 Type

51A	1	520	No. 295AK desk set box and Nos. 1293AD, AE, AK, AL; 1317W, AD, AE and AW telephones.....	\$1.60
51B	1	520	No. 1336F telephones. Same as No. 51A except is moistureproofed.....	1.60
51C	2 (parallel)	57	Inter-phones.....	1.00
51E	2 (parallel)	57	Inter-phones. Consists of a No. 51C mounted on a base	1.30
51F	1	.45	Nos. 101A, B; 102A, B, C and D Selector Sets.....	.80

No. 54 Type

54A	3	1300 (inner) 85 (outer front) 85 (outer rear)	Combined battery feed and holding coil for No. 550 P.B.X. switchboards.....	} On request
54-B	2	400 (inner) 40 (outer)		

No. 31 Type

For use with lightning arresters for the protection of machines connected to overhead D.C. or A.C. power circuits. Mounted on a temporary wooden base for shipment.

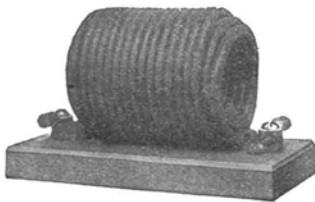

No. 31B

Telephone Apparatus and Supplies

Code No.	Capacity Amperes	List Price Each
31B	25	\$7.10
31D	50	12.40
31F	100	29.30
31H	150	42.80
148		

**RINGERS**

With the exception of the Nos. 32 and 40 types the following ringers are standard with black finished gongs. Orders for unmounted ringers will be filled accordingly unless otherwise specified. We are however prepared to furnish nickel-plated gongs when desired except in the case of Nos. 16BG and 45BG ringers.



No. 38 Type

**Unbiased Ringers**

Code No.	Approx. Resistance Ohms	Gongs		Mounts in Woodwork		Use	List Price Each
		Code No.	Diam. Ins.	Diam. Ins.	Ins.		
2AG	1000	25A	2½	¾	¾	Local battery (magneto) tele-phones.....	\$2.90
2FG	1600	25A	2½	¾	¾	Local battery (magneto) tele-phones.....	On request
4BG	2500	25A	2½	¾	¾	Nos. 1293AD and AE telephones.	On request

**No. 16 Type**

16BG	2500	24A	2	...	...	No. 358 type desk set boxes and No. 1357 type telephones....	\$3.60
------	------	-----	---	-----	-----	--	--------



No. 51 Type

**No. 38 Type**

38AG	1000	26A	3	5/8	} Local battery (magneto) tele-phones.	\$2.90
38BG	2500	26A	3	5/8		3.80
38FG	1600	26A	3	5/8		3.80
51AG	1000	25A	2½	5/8		2.90
51BG	2500	25A	2½	5/8		3.80
51FG	1600	25A	2½	5/8		3.80
53AG	1000	25A	2½	½		2.90
53BG	2500	25A	2½	½		3.80
53FG	1600	25A	2½	½	3.80	

**No. 40 Type**

40AG	1000	22 type	1 1/3	...	Adapted for use on	\$3.70
40BG	2500	22 type	1 3/4	...	magneto switch-boards instead of	4.60
40FG	1600	22 type	1 3/4	...	drops or signals.	4.60

**No. 43 Type**

†43NG	88	26A	3	5/8	No. 127H extension bell.....	\$3.40
-------	----	-----	---	-----	------------------------------	--------

**No. 45 Type**

45BG	2500	20	3	5/8	Telephones lo-cated in mines and other damp places. Treated to resist the ac-tion of moisture and gases.....	\$3.80
------	------	----	---	-----	--	--------

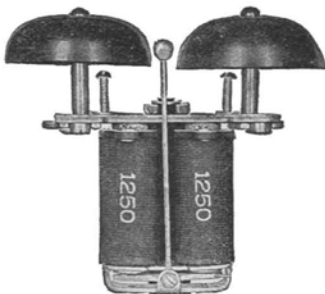

No. 53 Type

\*Spacers to adapt ringers to ½ inch or ¾ inch woodwork are furnished if specified in the order.

† The No. 43NG has two windings on each core so connected that the ringer is balanced and non-inductive from its common or central point to the two line terminals. It performs the function of a split retardation coil as well as that of an ordinary ringer. The ringer can be operated with a No. 22A generator on block wires having a resistance of 1800 ohms.

**RINGERS**

**Biased Ringers**

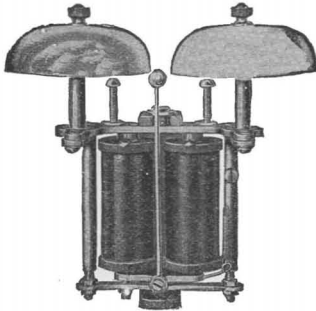

No. 6 Type

**No. 6 Type**

Code No.	Approx. Resistance Ohms	Gongs		Woodwork Ins.	Use	List Price Each
		Code No.	Diam. Ins.			
6AG	1000	25A	2 1/2	5/8	Central battery telephones for alternating current ringing.	\$2.90
8AG	1000	25A	2 1/2	3/8		
6BG	2500	25A	2 1/2	5/8	Telephones for pulsating or super-imposed current, 4-party selective ringing.	\$3.80
9BG	2500	25A	2 1/2	3/8		

**No. 32 Type**

32BG	2500	13	1 3/4	...	{ No. 1330 type } telephones.	\$3.60
------	------	----	-------	-----	----------------------------------	--------

**No. 42 Type**

42AG	†	25A	2 1/2	3/8	Central battery and magneto telephones for pulsating or super-imposed current 4-party selective ringing.	\$3.20
4SAG	†	25A	2 1/2	1/2		3.20
52AG	†	25A	2 1/2	1 1/8		3.20

**No. 46 Type**

46BG	2500	26A	3	*5/8	Telephones for pulsating or super-imposed current 4-party selective ringing.	\$3.80
49BG	2500	25A	2 1/2	*5/8		3.80
54BG	2500	25A	2 1/2	1/2		3.80

**No. 47 Type**

47BG	2500	26A	3	*5/8	Magneto telephones for centerchecking and central office selective signaling service.	\$3.80
47FG	1600	26A	3	*5/8		3.80
50BG	2500	25A	2 1/2	*5/8		3.80
55BG	2500	25A	2 1/2	1 1/2		3.80
55FG	1600	25A	2 1/2	1/2		3.80

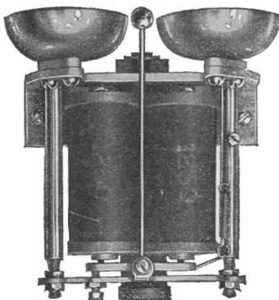

No. 32 Type

**Harmonic Ringers**

**No. 41 Type**

Have gong posts adapted for mounting on 5/8 inch woodwork.

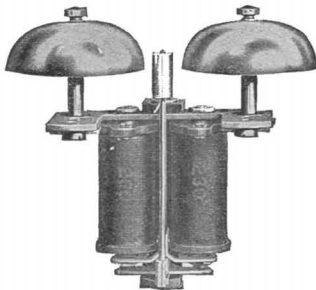

No. 41 Type

Code No.	Frequency Cycles per Second	Gongs		Use	List Price Each
		Code No.	Diam. Ins.		
41RG	16 2/3	25A	2 1/2	Central battery or magneto telephones for harmonic ringing, 4-party selective service.	\$5.40
41NG	33 1/3	25A	2 1/2		5.40
41TG	50	25A	2 1/2		5.40
41UG	66 2/3	25A	2 1/2		5.40

\*Spacers to adapt ringers to 1/2 inch or 3/8 inch woodwork are furnished if specified in the order.

†Has an inductive winding of approximately 1000 ohms and a non-inductive winding of approximately 3000 ohms. The two windings are connected in series and the junction brought out to an extra terminal for use in connecting an extension bell.

**RINGER INDICATORS**

Can be used in connection with No. 40 type switchboard ringers to indicate the calling line.

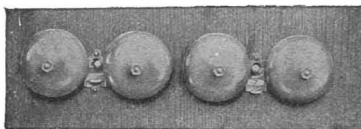

No. 1A Ringer Indicators  
Telephone Apparatus and Supplies

Code No.	List Price Each
1A.....	\$0.80

## RINGERS

### Repair Parts for Nos. 6-A and 38 Types

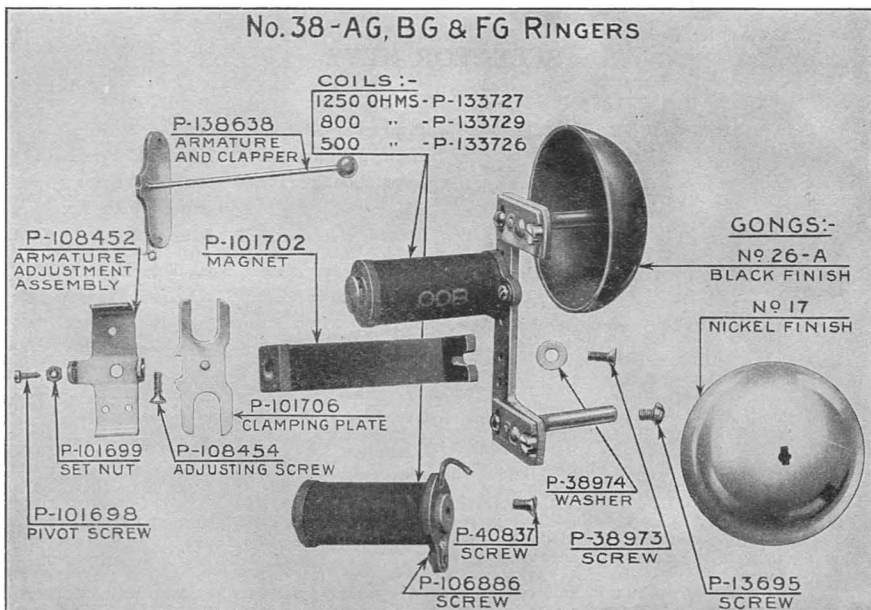
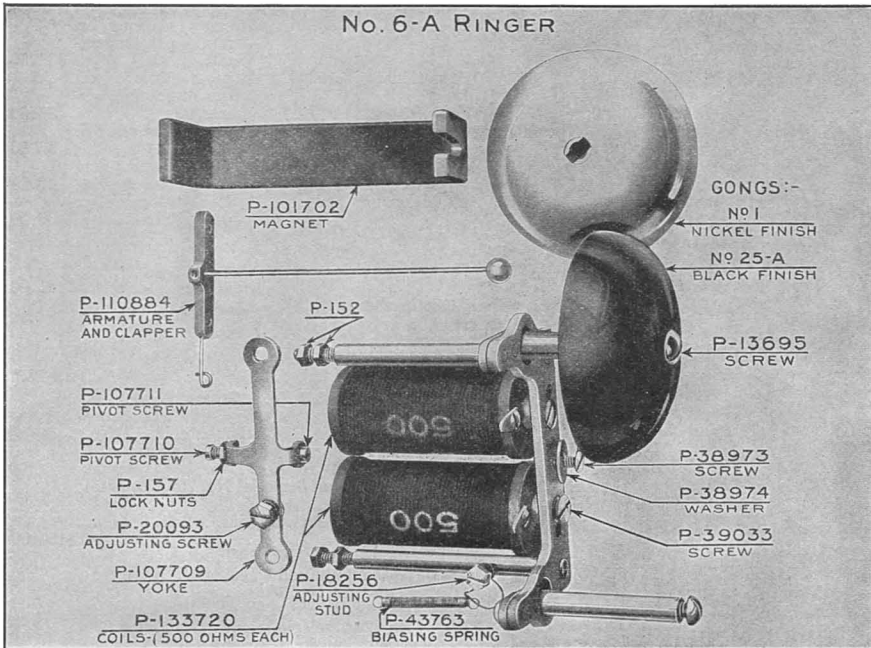

**SELECTORS**

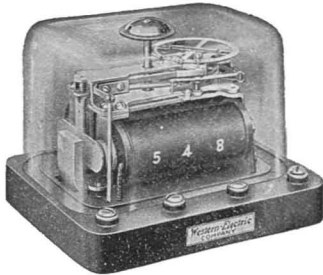

No. 60A Selector

		D. C. Selectors		List Price
Code No.	Capacity	Resistance Ohms	Used	Each
50A	48 stations.	3750	At way stations on train dispatching circuits.	\$36.50
50B	125 stations.	16000	At way stations on train dispatching circuits.	36.50
50C	48 stations.	9.4	At way stations in No. 102C selector sets.	36.50
50D	48 stations.	16000	In No. 1A semaphore sets.	40.00
50F	65 stations.	9.4	At way stations in No. 102F selector sets.	36.50
<b>New A. C. Selector</b>				
60A	78 stations*	15000	At way stations in No. 160A selector sets.	41.00

\*Special settings up to 253 stations can be furnished.

**SELECTOR APPARATUS CASES**

For use at dispatchers' stations on railway train dispatching circuits.

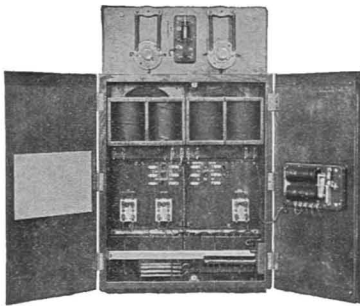

No. 53A Selector Apparatus Case

Code No.	Description	List Price Each
53A	Equipped with 2 No. 58G protectors, 2 No. 5AD retardation coils, 8 No. 21AA condensers, 2 No. 18AK resistances, 1 No. 18G resistance, 1 No. 35D resistance, 1 No. 12019 relay, 1 No. 12020 circuit breaker, and 3 special No. 709 Trumbull switches. Dimensions: 1 ft. 4 $\frac{1}{8}$ ins. x 2 ft. 7 $\frac{3}{4}$ ins. x 12 $\frac{3}{8}$ ins.	\$154.00
60A	Equipped with 2 No. 58G protectors, 2 No. 5AD retardation coils, 8 No. 21AA condensers, 2 No. 18AK resistances, 1 No. 18G resistance, 1 No. 122EW relay, 1 No. 26A telegraph relay, 1 No. 12020 circuit breaker, 3 No. 709 Trumbull knife switches. Dimensions: 1 ft. 4 $\frac{1}{8}$ ins. x 2 ft. 7 $\frac{3}{4}$ ins. x 12 $\frac{3}{8}$ ins.	154.00

**SELECTOR KEYS**

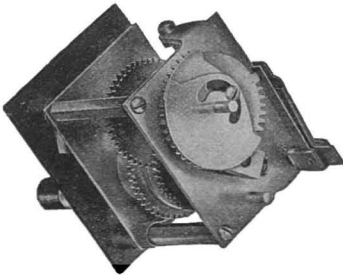

No. 50A Selector Key

Code No.	Description	Used In	List Price Each
*50A	Individual key. Can be adjusted to select any station from 1 to 35.	Nos. 50A, B or C selector key cases. At dispatcher's office. With No. 50A selectors.	\$7.70
*50B	Individual key. Can be adjusted to select any station from 1 to 48.	Nos. 50A, B or C selector key cases. At dispatcher's office. With No. 50A selectors.	7.70
50C	Individual key. Can be adjusted to select any station from 6-1 to 12-5.	Nos. 50A, B or C selector key cases. At dispatcher's office. With No. 50B selectors.	\$8.80
*50D	Individual key. Can be adjusted to select any station from 13-1 to 18-5.	Nos. 50A, B or C selector key cases. At dispatcher's office. With No. 50B selectors.	8.80
*60A	Individual key. Can be adjusted to select any station from 1 to 78, and also for advancing all selectors to the time receiving position.	Nos. 60A, 60B and 60C selector key cases, for calling No. 60A selectors.	8.80

\*NOTE: All No. 50 and 60 type keys can be removed separately from their key cases without disturbing the circuit of any other key in the case.

**SELECTOR KEYS—Continued**

Code No.	Description	Used in	List Price
*50E	Individual key. Can be adjusted to select any station from 1 to 50.	Nos. 50A, B or C selector key cases. At dispatcher's office. With No. 50C selectors.	\$8.80
*50F	Individual key. Can be adjusted to select any station from 1-3 to 21-1.	Nos. 50A, B or C selector key cases. At dispatcher's office. With No. 50F selector.	8.80

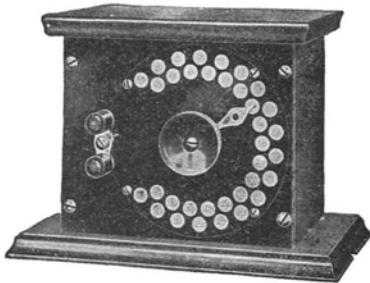

No. 51D Selector Key

Code No.	Description	Used in	List Price
51C	Inter-calling key. Capacity 49 stations. Mounts 2 No. 34B resistances.	Inter-calling selective circuits at all way stations. With No. 50A selector.	\$48.50
51D	Inter-calling key. Capacity 35 stations. Mounts 2 No. 34B resistances.	Inter-calling selective circuits at all way stations. With No. 50A selector.	41.00
53A	Inter-calling key. Capacity 55 stations. Mounts 2 No. 34B resistances.	Inter-calling selective circuits at all way stations. With No. 50B selector.	61.00

\*NOTE: All No. 50 type keys can be removed separately from their key cases without disturbing the circuit of any other key in the case.

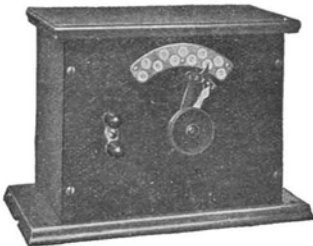

No. 53A Selector Key

**SELECTOR KEY CASES**

Code No.	Capacity Keys	Description	Dimensions	List Price
50A	24	Cabinet for mounting No. 50 type keys. 4 rows of 6 keys per row.	15¼ x 5⅝ x 12½ ins.	\$19.50
50B	36	Cabinet for mounting No. 50 type keys. 4 rows of 9 keys per row.	21¼ x 5⅝ x 12½ ins.	23.50
50C	50	Cabinet for mounting No. 50 type keys. 5 rows of 10 keys per row.	23¼ x 5⅝ x 15½ ins.	27.50
60A		Same as No. 50A but designed to mount No. 60 type selector keys.		19.50
60B		Same as No. 50B but designed to mount No. 60 type selector keys.		23.50
60C		Similar to No. 50C but designed to mount No. 60 type selector keys in 4 horizontal rows of 12.		27.50



No. 59A Selector Key Case

**SELECTOR KEY SPACES**

Code No.	Description	Used in	List Price
50A	Key spaces. Black finish.	No. 50A, B and C key cases in spaces not equipped with keys.	\$0.90



No. 101A Selector Set

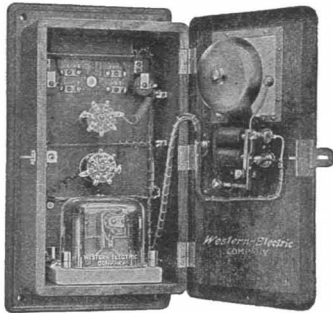

No. 101A Selector Set Open

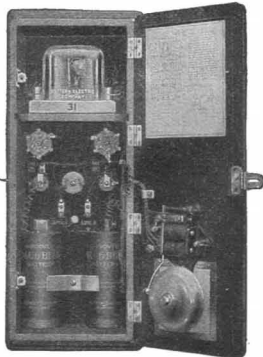

No. 102A Selector Set Open

**SELECTOR SETS**

Code No.	Equipment	Dimensions	Used at	List Price Each
*101A	Box equipped with: 1 No. 101402 bell. 2 No. 51F retardation coils. 1 No. 21H condenser. 1 No. 1F resistance. 1 No. 50A selector.	13 <sup>3</sup> / <sub>4</sub> x 9 <sup>1</sup> / <sub>4</sub> x 6 <sup>1</sup> / <sub>4</sub> ins.	Way stations on train dispatching circuits operated on central energy basis.	\$49.50
*101B	Same as No. 101A, except equipped with: No. 50B selector and No. 21U condenser instead of a No. 21H.			49.50
160A	Box similar in appearance to No. 101A. Equipped with: 1 No. 60A selector. 1 No. 60C ringer. 2 No. 21AA condensers. 2 No. 51F retardation coils. 1 48000 ohms resistance.	13 <sup>3</sup> / <sub>4</sub> x 9 <sup>1</sup> / <sub>4</sub> x 6 <sup>1</sup> / <sub>4</sub> ins.	Way stations on A.C. train dispatching circuits.	53.00
†102A	Box equipped with: 1 No. 101404 bell. 2 No. 51F retardation coils. 1 No. 5G resistance. 1 No. 50A selector. Arranged for, but not equipped with 2 dry cells.	10 <sup>3</sup> / <sub>4</sub> x 9 <sup>1</sup> / <sub>4</sub> x 6 <sup>1</sup> / <sub>4</sub> ins.	Way stations on train dispatching circuits operated on local battery basis.	49.50
†102B	Same as No. 102A, except equipped with: a No. 50B selector and 1 No. 5T resistance in place of No. 5G.			50.00
†102C	Similar to No. 102A. Box equipped with: 1 No. 50C selector, 1 No. 190M relay, 2 No. 51F retardation coils, 1 No. 101404 bell, 1 No. 5G resistance, 1 spl. No. 43 retardation coil.			69.00
†102E	Similar to No. 102A. Box equipped with: 1 No. 50C selector, 1 No. 190M relay, 2 No. 51F retardation coils, 1 No. 101404 bell.			59.50
†102F	Similar to No. 102A. Box equipped with: 1 No. 50F selector, 1 No. 190M relay, 2 No. 51F retardation coils, 1 No. 5G resistance, 1 No. 120818 bell.			62.00

NOTE: \*Nos. 101A and 101B sets are arranged for but not equipped with 2 No. 34A resistances.

†Nos. 102A, B, C, E and F sets are arranged for but not equipped with 1 No. 34A resistance. These resistances are ordered separately in accordance with the circuit requirements.

## SEMAPHORE AND TELEPHONE EQUIPMENT

### Selectively Operated



Semaphore, Selector and Telephone Apparatus Along Right-of-way

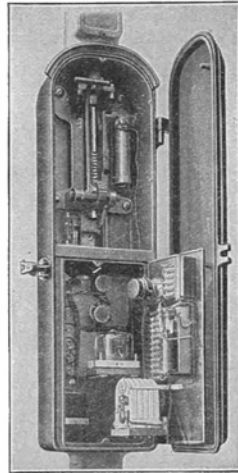

Interior View

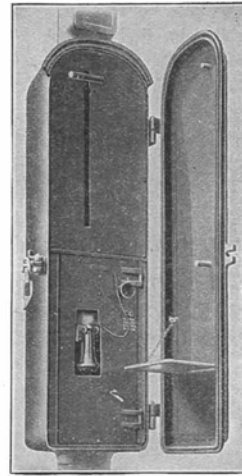

Selector Signal Mechanism, and Telephone Apparatus Case

The Western Electric Combined Selectively operated Semaphore and Telephone Equipment can be used and operated in connection with a regular telephone train wire.

Particularly adapted to steam roads who do not find it practicable to keep an operator on duty at every station the entire twenty-four hours. It can be used independently or as an auxiliary to the regular telephone train dispatching system.

Electric Railways will also find this equipment of great assistance in operating trains.

It can be installed either at the station or any point along the right-of-way—a siding for example. The dispatcher sets the arm in the same manner as calling a way station and is able to tell absolutely whether the arm selected came to the desired position. By means of the telephone equipment the train crew and the dispatcher are in immediate communication as soon as the train is stopped.

The weatherproof apparatus box is locked and can be opened only by keys in the possession of the proper employees.

The semaphore is of standard make and is furnished in either the upper or lower quadrant types as desired. The Semaphore blade itself can be furnished in any style or shape desired in order to conform to the practice of the railroad purchasing the equipment.

The telephone and selector apparatus is protected from the weather and all parts are moisture-proof. Standard Western Electric Railway telephone equipment is used throughout.

In ordering semaphores, the following information should be given:

Height of mast—21 feet is standard.

Upper quadrant—left or right

or

Lower quadrant—left or right.

Shape and color of blade.

Double or single spectacles.

Color of lenses.

Eight-day burners will be provided unless otherwise specified.

Information and prices on request.

SIGNALS



No. 4E, No. 2 Mounting



No. 32A

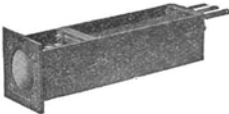

No. 34A



No. 42A Signal on No. 79 Mounting

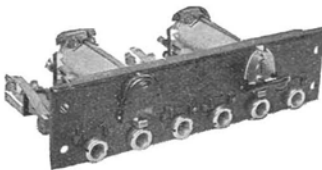

No. 5A Signal Group

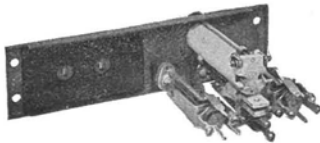

No. 6A Rear View  
Telephone Apparatus and Supplies

Switchboard Type

The No. 4 type has two coils and is used principally as a line signal in private exchanges employing magnetic signals and operating on a central battery basis.

The No. 32 type has a single coil and is used principally as a line and supervisory signal in cordless private exchange switchboards.

The No. 34 is used as a line signal in the No. 9 switchboard and in the trunk circuits of the No. 105 magneto switchboard.

The No. 41B is used in the cord circuits of the No. 9 switchboard.

The No. 42A is used as a busy signal with multiple toll line jacks and mounts on same centers as jacks.

The Nos. 4, 34 and 41 types are numbered in paint on the shutter, as specified. Furnished unnumbered, unless otherwise specified.

Code No.	Resistance (Ohms)	*List Price Each
4A	98	\$2.60
4E	500	2.70
4J	400	2.40
32A	33.3	3.40
32B	50	3.60
32C	525	3.60
34A	86	3.20
34B	300	3.40
41B	2 windings—100 each	5.20
42A	100	1.50

\*Prices do not include mountings.

SIGNAL GROUPS

These consist of jacks and combined jacks and signals assembled on a signal mounting, and are used on switchboards for receiving signals and making connections to a through toll line. Furnished less number plates unless otherwise specified. If number plates are ordered, specify numbering desired.

Code No.	Consists of	Dimensions (Inches)	List Price Each
2A	{ 1 No. 23C combined jack and signal (unless otherwise specified) 2 No. 199 jacks 1 No. 91B signal mounting }	2 1/4 x 2 1/4	{ On request
5A	{ 2 No. 23C combined jacks and signals (unless otherwise specified) 4 No. 199 jacks 1 No. 104B signal mounting }	1 3/4 x 6 3/8	{ On request
6A	{ 1 No. 23C combined jack and signal (unless otherwise specified) 2 No. 199 jacks 1 P-112347 apparatus blank 1 No. 104B signal mounting }	1 3/4 x 6 3/8	{ On request

**SIGNAL MOUNTINGS**



No. 62 Signal Mounting

The following are the principal mountings used with signals, combined jacks and signals and supervisory signals.

**For Central Battery Signals**

Code No.	For Signals	Number of Signals per Strip	Size of Face Plate Inches	List Price Each
2	4 type	10	15 x $\frac{9}{16}$	\$1.40
3	4 type	15	22 x $\frac{9}{16}$	2.00
34	34 type	20	24 $\frac{9}{16}$ x $1\frac{3}{8}$	5.40
60	34, 41 type	15	24 $\frac{9}{16}$ x $1\frac{3}{8}$	4.10
61	34 type	20	24 $\frac{9}{16}$ x $1\frac{3}{8}$	5.40
62	34, 41 type	12	21 x $1\frac{3}{8}$	3.30
77	42 type	10	9 $\frac{3}{8}$ x $\frac{7}{8}$	1.40
78	42 type	10	7 $\frac{3}{8}$ x $\frac{7}{8}$	1.40
79	42 type	20	9 $\frac{3}{8}$ x $\frac{7}{8}$	2.70
82	42 type	10	11 $\frac{1}{8}$ x $\frac{7}{8}$	1.40
83	42 type	20	11 $\frac{1}{8}$ x $\frac{7}{8}$	2.70
94A	4 type	5	7 $\frac{3}{8}$ x $1\frac{1}{2}$	.70

**For Combined Jacks and Signals**

Code No.	For Signals	Number of Signals per Strip	Size of Face Plate Inches	List Price Each
80B	2, 3, 6, 7, 8, 9, 12	1	1 $\frac{1}{8}$ x $2\frac{1}{4}$	} Prices on request
80C	4, 5, 11	1	1 $\frac{1}{8}$ x $2\frac{1}{4}$	
81E	2, 3, 6, 7, 8, 9, 12	5	6 $\frac{3}{8}$ x $1\frac{3}{4}$	
81F	4, 5, 11	5	6 $\frac{3}{8}$ x $1\frac{3}{4}$	
88B	2, 3, 6, 7, 8, 9, 12	10	11 $\frac{3}{8}$ x $1\frac{7}{8}$	
88C	4, 5, 11	10	11 $\frac{3}{8}$ x $1\frac{7}{8}$	
89B	22, 23, 26, 27	5	6 $\frac{3}{8}$ x $1\frac{3}{4}$	
89C	24, 31	5	6 $\frac{3}{8}$ x $1\frac{3}{4}$	
92B	22, 23, 26, 27	1	1 $\frac{1}{8}$ x $2\frac{1}{4}$	
92C	24, 31	1	1 $\frac{1}{8}$ x $2\frac{1}{4}$	
100	42C	5	5 $\frac{3}{8}$ x $1\frac{3}{4}$	\$0.70

**For Supervisory Signals**

Code No.	For Signals	Number of Signals per Strip	Size of Face Plate Inches	List Price Each
80D	10, 13	1	1 $\frac{1}{8}$ x $2\frac{1}{4}$	} Prices on request
81D	10, 13	5	6 $\frac{3}{8}$ x $1\frac{3}{4}$	
88D	10, 13	10	11 $\frac{3}{8}$ x $1\frac{7}{8}$	
90A	30, 33	2 on left end of plate	6 $\frac{3}{8}$ x $1\frac{3}{4}$	
90B	30, 33	3 on right end of plate	6 $\frac{3}{8}$ x $1\frac{3}{4}$	
90C	30, 33	5	6 $\frac{3}{8}$ x $1\frac{3}{4}$	

**SIGNAL PLUGS**



No. 4 Type Signal Plug

These are used for inserting in a jack to designate change of number, lines temporarily disconnected, lines arranged for calling only or similar purposes.

Heads are covered with opaque celluloid paint.

The white heads of the Nos. 1A and 3A may be written upon.

**For No. 193 Jacks**

Code No.	Color of Head	Dimensions—Inches— Diameter of Head Overall Length	List Price per 1000	Code No.	Color of Head	Dimensions—Inches— Diameter of Head Overall Length	List Price per 1000
1A	White	} $\frac{21}{64}$ } $\frac{33}{64}$	\$10.80	2E	Yellow	} $\frac{21}{64}$ } $\frac{33}{64}$	\$10.80
2B	Red			2F	Blue		
2C	Slate			2G	Dark green		
2D	Black			2H	Light green		

**For No. 92 Jacks**

Code No.	Color of Head	Dimensions—Inches— Diameter of Head Overall Length	List Price per 1000	Code No.	Color of Head	Dimensions—Inches— Diameter of Head Overall Length	List Price per 1000
3A	White	} $\frac{21}{64}$ } $\frac{33}{64}$	\$10.80	4E	Yellow	} $\frac{5}{16}$ } $\frac{33}{64}$	\$10.80
4B	Red			4F	Blue		
4C	Slate			4G	Dark green		
4D	Black			4H	Light green		

Information and prices on signal plugs to fit other types of jacks than those listed, will be furnished upon request.

### SUPERVISORY SIGNALS

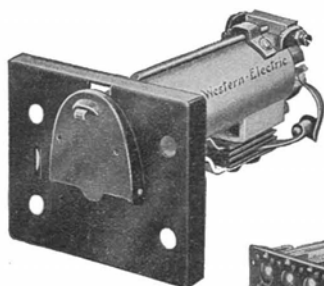

No. 30C Supervisory Signal Shutter Restored

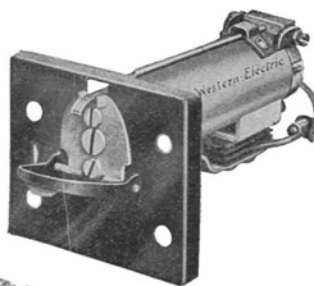

No. 30C Supervisory Signal Shutter Operated

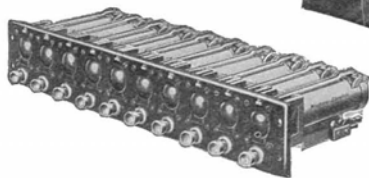

No. 10C Supervisory Signals on No. 88D Mounting

Code No.	Approximate Resistance Ohms	Description	Mountings No.	*List Price Each
10C	240	A magneto supervisory signal similar to the No. 2 type combined jack and signal, except jack springs are omitted and a push button for restoring the signal ball is added.	80D, S1D and SSD	\$4.20
30C	350	A manually restored shutter type magneto supervisory signal, to be used in connection with the No. 22 type combined jack and signal or as a line drop.	90A, B and C	2.70
33A	205 (Inner) 290 (Outer)	A manually restored shutter type magneto supervisory signal with two windings. To be used in connection with the No. 22 type combined jack and signal.	90A, B and C	4.00

\*Prices do not include mountings.

### SUBSCRIBER SETS

Subscriber sets are not listed under this heading in this catalog. The apparatus required will be found listed under telephones, inter-phones, desk set boxes, extension bells or hand generator boxes as the case may be.

### SWITCHES

#### Booth Switches

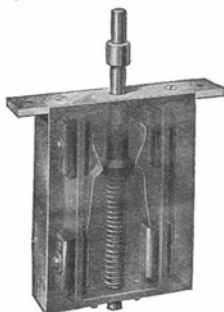

No. 1A Booth Switch

Code No.	Description	List Price Each
1A	For disconnecting siding telephone located in a booth or pole box, from the line when the booth or pole box is locked. Operates when hasp is placed over the staple and held in place by padlock. Guards the telephone set against injury from lightning discharges.	\$7.20

#### Knife Switches

##### PORCELAIN BASE—15 AMPERES

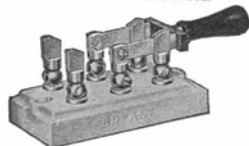

No. 1041 Knife Switch

List No.	Description	List Price Each
1001	Single pole, single throw	\$0.55
1039	Single pole, double throw	.96
974	Double pole, single throw	.68
1041	Double pole, double throw	1.19

**SWITCHES**

**Knife Switches—Continued**

**SLATE BASE—15 AMPERES**

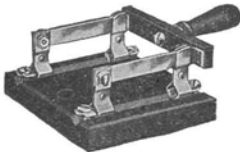

**No. 1638 Knife Switch**

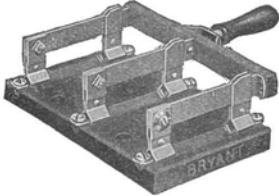

**No. 1640 Knife Switch**

List No.	Description	List Price Each
1638	Double pole, single throw . . . . .	\$0.80
1656	Double pole, double throw . . . . .	1.38
1640	Triple pole, single throw . . . . .	1.67
1658	Triple pole, double throw . . . . .	2.24

**Round Wood Base Switches**

A substantial spring lever switch arm which snaps over contact point, making it jar-proof. For use wherever a positive lever switch is desired.

Furnished in oak or any regular wood finish.

List No.	Description	List Price Each
108	1 point . . . . .	\$0.65
108	2 point . . . . .	.98

**SWITCH HOOKS**



**No. 142A Switch Hook**



**No. 108 Switch**



**No. 141A Switch Hook**



**No. 143 Type Switch Hook**

Code No.	Description	Finish	Contacts	List Price Each
140S	Short lever, self-contained	Black	2 front	\$1.40
143A	Short lever, self-contained	Nickel	2 front	1.40
143B	Short lever, self-contained	Nickel	2 front, 1 back	1.60
143G	Short lever, self-contained	Nickel	2 front, 1 passing ground	1.80
143Y	Short lever, self-contained	Black	2 front	1.40
141A	Brass wire hook threaded at one end and provided with a cap staked on. For use with No. 1002 and 1003 type hand sets.	Nickel	.....	.06
142A	Punched dummy hook for use with No. 1020 type desk stands when an auxiliary receiver is used.	Nickel	.....	.32
142B	Same as No. 142A except finish.	Black	.....	.32

**SWITCHING AND TESTING PANELS**

We are prepared to furnish switching and testing panels to take care of any requirements. These panels are equipped with switches as shown and are used for testing and patching purposes on train dispatching and simplex block circuits.

The dimensions of the No. A-102412 shown are approximately 21 x 15 x 1 3/16 ins.

Prices furnished on request.

159 **Telephone Apparatus and Supplies**

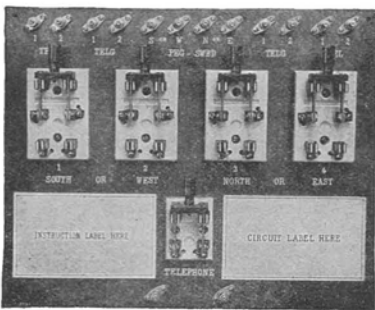

**No. A-102412 Switching Panel**

## TELEPHONE SWITCHBOARDS AND SYSTEMS

### General

The line of non-multiple type switchboards is complete and includes designs that will satisfy every demand for telephone exchange equipment.

Magneto switchboards are offered in capacities varying from 4 to 330 lines.

Private Exchange (P.X.) and Private Branch Exchange (P.B.X.) switchboards, such as our sectional unit type, range in capacities from 20 to 80 lines and over. P.X. and P.B.X. boards are also made up in either desk or cabinet style, ranging in capacity from 60 to 600 lines.

Toll switchboards are offered in either desk or cabinet style and have capacities from 40 lines upward.

Common battery non-multiple switchboards are of the cabinet type and range from 260 to 520 lines in capacity.

Multiple type equipments are also manufactured for regular exchange use, for private branch exchanges and for toll offices. These equipments range in capacity from 300 lines to 10,500 lines.

Due to the varied requirements existing for multiple type equipments, these are not standardized to the same extent as are the non-multiple line of switchboards. Representative installations are, however, illustrated in the following pages.

We will, upon request, gladly make studies, recommend equipments and furnish engineering data and prices applying to any type of switchboard.

### Definitions of Terms

In describing the various telephone switchboards and their features, the following terms occur:

#### AUDIBLE CODE SIGNALING

To enable the switchboard operator to distinguish various code rings on bridging lines an "audible code signaling" feature can be provided. This is accomplished by using No. 6 or No. 26 type combined jacks and signals, having a local contact which is closed during the ringing interval. This contact operates a local alarm bell circuit, which repeats the codes sounded.

#### CENTRAL OFFICE SELECTIVE SIGNALING

This signifies that the subscriber can signal the central office without ringing the other bells on a rural line, or signal the other parties on the line without operating the switchboard signal. For this service the No. 7 or No. 27 type combined jacks and signals are used, permitting one side of the signal winding to be connected to ground. Push button type telephones are used on these lines.

For diagram and information on telephones, see descriptive matter under magneto telephone sets.

#### COMBINED JACK AND SIGNAL

This is the term given to the Western Electric line signal where the jack is mounted immediately under its associated signal. These signals are automatically restored when the answering plug is inserted.

#### CORD CIRCUIT, COMBINATION

This type of cord circuit is so designed that one cord of the pair may be used on either central battery or magneto lines, the other cord being used for one class of service only. The latter may be either central battery or magneto, depending upon the class of service involved.

#### CORD CIRCUIT, UNIVERSAL

This type of cord circuit is so designed that each of the two connecting cords is adapted for making connections with either magneto or central battery lines. The circuit automatically adapts itself to either class of service by the operation of relays which form a part of the circuit. The circuit may be used for connecting two magneto lines and two central battery lines or one magneto line and one central battery line.

#### CORD CIRCUIT, JACK LISTENING TYPE

In this type of cord circuit the operator can listen in on a line by inserting the plug of the listening cord into a listening jack. One of these listening jacks is associated with each pair of connecting cords. Plugging in the listening cord bridges the operator's telephone set across the line.

## TELEPHONE SWITCHBOARDS AND SYSTEMS

### Definitions of Terms (Continued)

#### CORD CIRCUIT, KEY LISTENING TYPE

In this type of cord circuit the operator can listen in on a line by merely operating the listening key handle of a cord circuit key. One of the keys is associated with each pair of cords and the corresponding supervisory drop.

#### CORD CIRCUIT, NON-HANG-UP TYPE

In this type of cord circuit it is possible under all conditions for both subscribers, at the completion of a conversation, to operate the clearing-out signal on the operator's cord circuits.

#### CORD CIRCUIT, NON-RING-THROUGH TYPE

This type of cord circuit is so equipped that it is impossible for any subscriber in "ringing-off" to ring any of the bells on the connected line.

#### CORD CIRCUIT, NON-HANG-UP NON-RING-THROUGH TYPE

This type of cord circuit includes the features of the non-hang-up and the non-ring-through circuits.

#### LINES WITH LINE RELAYS

In central battery private exchanges and private branch exchange switchboards, it is necessary to use line relays in order to operate lines that have over 30 ohms resistance. This corresponds approximately to an 800 foot line of No. 22 or a 1600 foot line of No. 19 B.&S. gauge copper wire.

#### REPEATING COILS IN MAGNETO SWITCHBOARDS

These are sometimes used at the switchboard end of a grounded circuit to eliminate noise when connecting metallic circuits. They are also used in cord circuits to provide the "non-hang-up, non-ring-through" feature. Repeating coils are also used in connection with cord circuits to connect noisy or unbalanced lines.

#### RINGERS USED AS SWITCHBOARD LINE SIGNALS

Ringers are slightly more sensitive than drops or signals, and are sometimes used on extremely long lines. They are also used sometimes where audible code signaling is desired. The Western Electric audible code signaling drop provides this feature without the sacrifice of the additional space required in which to mount ringers.

#### RINGER INDICATORS

These are provided on the ringers used in place of signals or drops where the operator is not constantly at the switchboard. They indicate which line has been calling by means of a sliding shutter actuated by the motion of the clapper.

#### RINGING, ONE WAY

This provides for ringing on the calling (front or nearest the operator) cords only.

#### RINGING, TWO WAY

This provides for ringing on the calling (front or nearest the operator) and also upon the answering (back or farthest from the operator) cords.

#### RINGING KEYS, INDIVIDUAL, FOR PARTY LINES

In this case the various parties on the party line can be signaled selectively directly by means of the cord circuit key associated with each cord circuit.

#### RINGING KEYS, MASTER, FOR PARTY LINES

In this case, the various parties on the party line can be signaled selectively, only by means of a master ringing key operated in conjunction with a cord circuit key. There is one master key for each operator's position.

## TELEPHONE SWITCHBOARDS AND SYSTEMS

### Definitions of Terms (Continued)

#### RINGING COMBINATIONS

For further information on classes of ringing service see general descriptions of magneto and central battery telephones.

**Single party, one-way or two-way ringing** provides for ringing one telephone only over the calling cord or over the calling or answering cord, respectively.

**Two-party, one-way, selective individual or selective master key (divided circuit)** provides for ringing one of two parties on the same line selectively over the calling cord only.

**Two-party, two-way, selective individual or selective master key (divided circuit)** provides for ringing one of two parties on the same line selectively over either calling or answering cord.

**Four-party, one-way, pulsating individual or pulsating master key** provides for signaling one of four parties on the same line selectively, over the calling cord only, by means of positive or negative pulsating current over either side of the line to ground.

**Four-party, two-way, pulsating individual or pulsating master key** provides the same service as the preceding combination except that ringing current can be sent out over either calling or answering cord.

**Four-party, one-way, harmonic individual or harmonic master key** provides for signaling one of four parties on the same line selectively, over the calling cord only, by means of harmonic current. In this case, the telephone ringers ring only when alternating current of a given frequency is sent over the line.

**Four-party, two-way, harmonic individual or harmonic master key** provides for the same service as the preceding combination except that ringing current can be sent out over either calling or answering cord.

**Eight-party, one-way, harmonic individual or harmonic master key** provides for the same service as the corresponding four-party combination except that any one of the eight parties on the same line can be signaled selectively over the calling cord only.

**Eight-party, two-way, harmonic master key** provides for the same service as the corresponding four-party combination except that any one of the eight parties on the same line can be signaled selectively over either calling or answering cord.

#### SUPERVISORY SIGNAL, MAGNETO

This signal, also known as a clearing-out drop, consists of a drop bridged across each cord circuit to indicate when a conversation has been completed. The current for operating this drop is furnished by the ring-off signal from the subscriber's telephone set generator.

#### SUPERVISORY SIGNAL, CENTRAL BATTERY

This consists of a lamp associated with each cord of the cord circuit. This lamp lights when a conversation is completed and each subscriber hangs up his receiver. It remains lighted until the connection is taken down. When making a connection, the lamp on the calling cord remains lighted until the called-for subscriber answers.

#### SUPERVISION, SINGLE

This term is used to describe a telephone switchboard cord circuit having only one "clearing-out" or "ring-off" drop. (For diagrams see description of No. 1200 type switchboards.)

#### SUPERVISION, DOUBLE

This term is used to describe a cord circuit having two "clearing-out" or "ring-off" drops, or two supervisory lamps, one per cord. (For diagrams see description of No. 1200 type switchboards.)

#### THROUGH TOLL LINES

These toll lines are those that loop through an intermediate office. For example, when a toll line connects A and C, and passes through an intermediate office B, code signaling is employed. A and C are called with one ring, and B with two rings.

By means of "cutoff" jacks at B, the one line is made to act as three. That is, either as a through circuit between A and C, or as two local circuits; one between A and B and the second between C and B.

#### TRANSFER CIRCUITS

These are used where a switchboard consists of three or more positions and a number of the subscriber line jacks are out of the reach of any one operator. The transfer circuits provide a means of extending the cord circuits to the positions in which the jacks appear.

#### TRUNK, RECORDING TOLL

This is a trunk circuit between the local switchboard and the toll switchboard that makes it possible for subscribers desiring toll connections to get in direct communication with the recording toll operator. When it is known that it will take some time to complete the toll call, the operator tells the subscriber to hang up and can then call him back to the line over the trunk.

## No. 1800 MAGNETO SWITCHBOARD

### Sectional Unit Type

This type of switchboard corresponds in general design to the familiar sectional unit book case, and is offered for installations that are comparatively small at the start but are expected to grow rapidly, and where the needs for the future are indefinite. An ultimate capacity of 50 lines has been set arbitrarily as the maximum that should be used with this type of switchboard. With a low calling rate, however, it is safe to assume that as many as 70 or 80 lines can be accommodated.

The No. 1800 sectional unit type switchboard has these features:

All the operating features, electrical and mechanical, of the large Western Electric switchboards are retained.

Easy to assemble a switchboard for any line or operating condition.

Necessary to buy only as much equipment as needed, switchboard capacity readily increased (by adding

All terminals and apparatus instantly accessible.

Apparatus, material, construction and finished product are standard Western Electric Quality Products, the best that can be produced.

To meet various requirements, there are different types of base or supporting units, cord units, line units and top units. To assemble a board it is then necessary to select, first, a base unit; second, a cord unit; third, one or more line units, and finally a top unit. These assemble readily in the order given, and provide a perfectly practical switchboard to which additional line units may be added at any time.

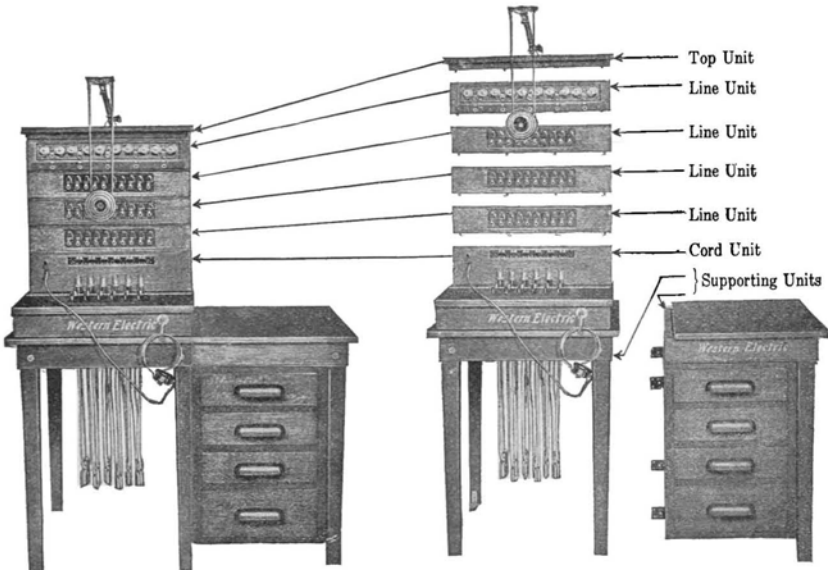

Method of Enlarging No. 1800 Switchboard—Capacity up to 50 lines

## No. 1800 MAGNETO SWITCHBOARD

### Specifications

Thoroughly seasoned, kiln-dried lumber is used to prevent warping and cracking; joints are all tongued and grooved, and securely fastened.

Steel bars are used in key shelf and face of units for mounting keys and signals, insuring perfect alignment.

Plug shelf is covered with  $\frac{1}{8}$  inch sole leather to protect it from the impact of falling plugs.

Line and cord units have hinged rear doors giving access to all terminals, apparatus and wiring.

Outside finish is a rich, golden oak. Interior of cabinets are shellaced to prevent warping and decay.

Cord circuit keys have springs mounted horizontally on edge to facilitate inspection and prevent dust from collecting on contacts. Keys have high insulation, plungers do not stick, and all parts are unusually sturdy.

Keys are fastened to steel framework by machine screws to permit of easy removal from top to key shelf.

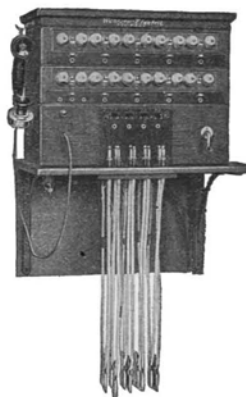

Wall Type—20 Lines  
Consists of:  
1—AA-1 Top Unit  
1—BA-7 Line Unit  
1—BB-7 Line Unit  
1—CA-1 Cord Unit  
1—D-1 Supporting Unit

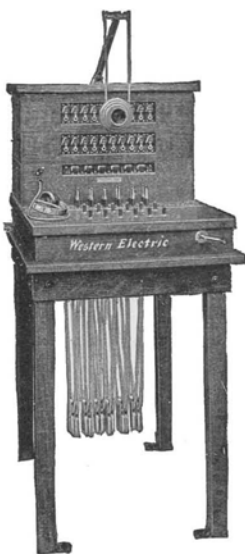

Floor Type—20 Lines  
Consists of:  
1—AA-2 Top Unit  
1—BA-12 Line Unit  
1—BA-13 Line Unit  
1—CA-6 Cord Unit  
1—D-3 Supporting Unit

### Data

#### SUPPORTING UNITS

- |          |  |
|----------|--|
| Code No. |  |
| D-1      | Bracket and board for screwing to wall, adapted for use with cord units having listening jacks.  |
| D-2      | Bracket and board for screwing to wall, adapted for use with cord units having listening keys.   |
| D-3      | Skeleton table for mounting any type of cord unit. When cord units arranged with listening jacks are used a D-5 supporting unit is also necessary. |
| D-4      | A unit comprising four drawers, which may be assembled with the skeleton table unit D-3.   |
| D-5      | A unit required in connection with the D-3 supporting unit as described.   |

#### TOP UNITS

- |      |  |
|------|--|
| AA-1 | Unit arranged for cord units equipped with hand set type operator's telephone.         |
| AA-2 | Unit equipped with transmitter arm arranged for suspended type operator's transmitter. |

#### CORD UNITS

Code No.	Cords, Jack Listening Type	Cords, Key Listening Type	Cord Repeating Coils Wired Capacity	Operator's Telephone Set Type
CA-1	4	....	2	Hand Set
CB-1	4	....	2	
CA-2	....	4 (Note 1)	2	Suspended Transmitter
CA-6	....	(6 Note 1)	2	
			(Note 2)	

## NO. 1800 MAGNETO SWITCHBOARDS

### Data

#### CORD UNITS (Continued)

**Note 1:** These cord circuits are arranged for two-way ringing. Wiring is provided for a master ringing key for party line work. When desired, a two-party or a four-party master key can be installed in the cord unit.

**Note 2:** Two of the cord circuits in each unit are wired for, but not equipped with, repeating coils. If repeating coils are required to eliminate noise when a grounded line is connected to a metallic line, order for each cord circuit a "Repeating Coil Group No. 1," consisting of a repeating coil and a condenser mounted on a common base. These are wired to screw type terminals on the base and are easily connected to the cord units.

**Note 3:** Jack listening type cord circuits are for use where traffic is light and the constant services of an operator are not required. Cord circuits arranged for key listening are for busy central offices and simplify the work of operating.

#### LINE UNITS

Code No.	No. 22 Type Combined Jacks and Signals	2500-ohm Ringers with Indicators	1600-ohm Ringers with Indicators	1000-ohm Ringers with Indicators
BA-12	10	....	....	....
BA-13	10 (Note 1)	....	....	....
BA- 7	....	5	....	....
BB- 7	....	....	5	....
BC- 7	....	....	....	5

**Note 1:** The combined jacks and signals in this unit are equipped with special contacts to provide "audible code signaling."

**Note 2:** The line units equipped with combined jacks and signals may be arranged for through toll circuits. Each through toll circuit equipped occupies the space of two combined jacks and signals and reduces the line capacity correspondingly.

### Information for Ordering a No. 1800 Switchboard

Order should call for

1 (Code No.)	.....	Top Unit
.. (Code No.)	.....	Line Units
.. (Code No.)	.....	Line Units
.. (Code No.)	.....	Line Units
1 (Code No.)	.....	Cord Unit
1 (Code No.)	.....	Supporting Unit
.. Through Toll Circuits in Code No.	.....	Line Unit
1	.....	Party Master Ringing Key
.. No. 1 Repeating Group Coils		

## No. 1200 TYPE MAGNETO SWITCHBOARDS

### Non-multiple—Automatically Restored Line Signals

The No. 1200 type switchboard series (Code Nos. 1220 to 1259) is designed for the medium size magneto exchange. The switchboards range in capacity from 105 lines to 330 lines. Additional capacity may be obtained by lining up two or more sections and making use of transfer trunks.

For exchanges where the ultimate capacity will exceed 330 lines non-multiple magneto switchboards are not recommended because of the resulting lower operating efficiency and lower grade of service. In such cases central battery or multiple type magneto switchboards should be installed.

### Condensed Specifications

#### Framework

Lumber is thoroughly seasoned and kiln-dried to prevent warping or cracking. Joints are tongued and grooved, no butt joints used. All joints are reinforced with steel angles.

Copper-plated steel framework is used to hold apparatus in face of board. Copper plating prevents rust and provides a better path and contact for switchboard ground, night alarm circuit, etc., by reducing resistance of framework joints. Steel framework is securely fastened to woodwork.

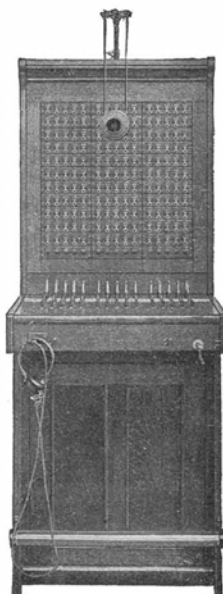

No. 1240D Switchboard

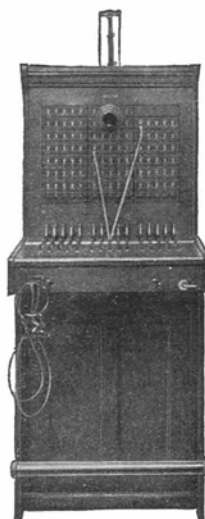

No. 1220D Switchboard

Steel framework is used in key shelf to provide a rigid support for keys and facilitate their removal. Key shelf has piano hinge along full length to give strength and good appearance.

Plug shelf is covered with  $\frac{1}{8}$  inch sole leather to prevent injury from impact of falling plugs.

Rear doors are removable and provided with dustproof frame.

Polished brass foot rails are provided.

#### Finish

Exterior surface is finished in rich golden oak, quarter-sawed. Interior is thoroughly shellacked to prevent warping and decay.

#### Wiring

Wiring as far as possible is run in cable forms and in accordance with a definite color scheme so that any one wire can be readily identified in any part of the switchboard.

Individual wiring in local and line cables is No. 22 B.&S. gauge double silk and cotton insulated copper wire.

Common circuit wiring is of No. 20 B.&S. gauge, black enameled, double silk and cotton insulated copper wire.

All wiring is neatly formed in cables and shellacked to increase insulation and prevent fraying in handling.

Line cables are of the moisture-proofed, beeswaxed core type with a flameproofed covering. All line cable forms are shellacked.

## No. 1200 TYPE MAGNETO SWITCHBOARDS

### Condensed Specifications (Continued)

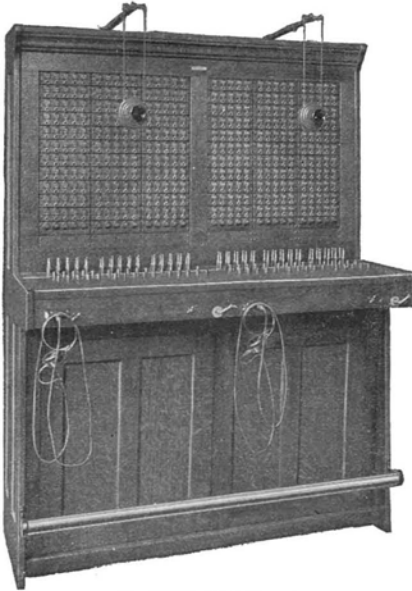

No. 1250D Switchboard

#### Equipment and Arrangement

All equipment is of the same high standard as that used in the large central battery equipments manufactured by the Western Electric Company for telephone companies throughout the country who demand the very best in quality and efficiency.

All apparatus is readily accessible and well spaced.

Line cable wires have clips at switchboard end for connecting the wires to the combined jacks and signals. No soldering iron is necessary to make or disconnect the connections at the line signals.

Combined jacks and signals are removable from face of board.

Cord circuit keys have springs mounted horizontally to facilitate inspection and to prevent dust from collecting on the contacts. Keys have high insulation, plungers do not stick, and all parts are unusually sturdy.

Keys are fastened to steel framework by machine screws to permit of easy removal from top of key shelf.

All wiring terminals are clearly designated.

Blueprints of all circuits are furnished, as are tools for making apparatus adjustments.

Switchboard Code No. (See Note 1)	No. of Positions	Line Capacity	Cord Capacity (See Note 2)	Line Cable Pairs
1220	1	105	15	105
1230	2 { left position right position	105 105	15 15	105 105
1240	1	165	15	165
1250	2 { left position right position	165 165	15 15	165 165

**Note 1:** The No. 1200 type magneto switchboards may be equipped with either No. 2 ball type combined jacks and signals and No. 10 ball type push button restored supervisory signals or No. 22 shutter type combined jacks and signals and No. 34 shutter type supervisory signals. Boards equipped with ball type signals are described by adding the suffix "C" to the switchboard code numbers; as for example, No. 1240C switchboard. Boards equipped with shutter type signals are described by suffixing the letter "D" to the switchboard code number; as for example, No. 1230D switchboard.

**Note 2:** The No. 1200 type non-multiple magneto switchboard is furnished with either single or double supervision cord circuits. Single supervision boards may, if desired, be equipped with five cord circuits having toroidal repeating coils and switching keys. Double supervision boards may be equipped with either the condenser type "non-hang-up" cord circuits, or the condenser repeating coil type "non-hang-up," "non-ring-through" cord circuits. The present No. 1200 types of switchboard, if arranged for single supervision, may be changed to a double supervision board simply by installing the necessary additional apparatus. (See diagrams on following page.)

## No. 1200 TYPE MAGNETO SWITCHBOARDS

## Condensed Specifications (Continued)

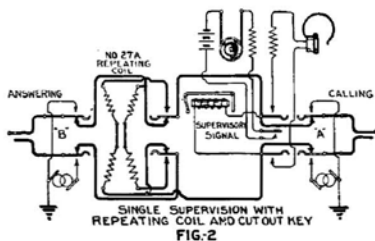
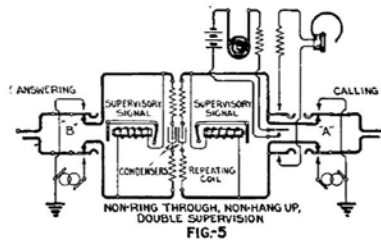
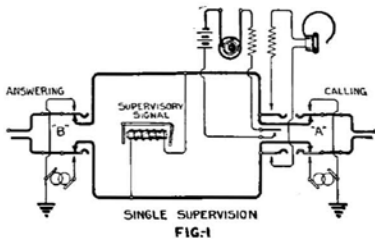

NOTE:  
FOR ONE WAY RINGING ONLY  
KEY 'A' IS FURNISHED  
FOR TWO WAY RINGING BOTH  
KEY 'A' AND 'B' IS FURNISHED

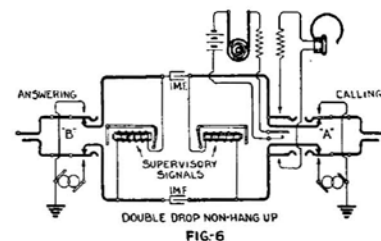

THE DROPS OF THIS CIRCUIT ARE NOT  
ABSOLUTELY SEPARATED OUT IN  
PRACTICE. IT WILL BE FOUND THAT  
THE CIRCUIT GIVES GOOD SATISFACTION

Cord Circuits for No. 1200 Types of Magneto Switchboard

**Note 3:** If through toll line equipment is desired, it must be noted that each two through toll lines occupy the space of one strip of five combined jacks and signals and reduce the line capacity correspondingly.

**Note 4:** The following ringing combinations are wired for and can be supplied as specified (for definitions of terms used, see page 162):

Single-party, one-way or two-way ringing.

Two-party, one-way, selective individual or selective master key (divided circuit, one side of line to ground).

Two-party, two-way, selective individual or master key (divided circuit, one side of line to ground).

Four-party, one-way, pulsating individual or pulsating master key.

Four-party, two-way, pulsating individual or pulsating master key.

Four-party, one-way, harmonic individual or harmonic master key.

Four-party, two-way, harmonic individual or harmonic master key.

Eight-party, one-way, harmonic individual or harmonic master key; and

Eight-party, two-way, harmonic master key.

## No. 1200 TYPE MAGNETO SWITCHBOARDS

### Information for Ordering a No. 1200 Type Switchboard

Order should call for:

- (a.) 1 No. .... C or ..... D switchboard, equipped with ..... subscriber lines, and arranged for ..... ringing
- (b.) Cord circuits per figure. .... with ..... ringing keys.
- (c.) ..... through toll lines.

(If audible code signaling or central office selective signaling is desired, information should so specify; giving number of lines to be equipped.)

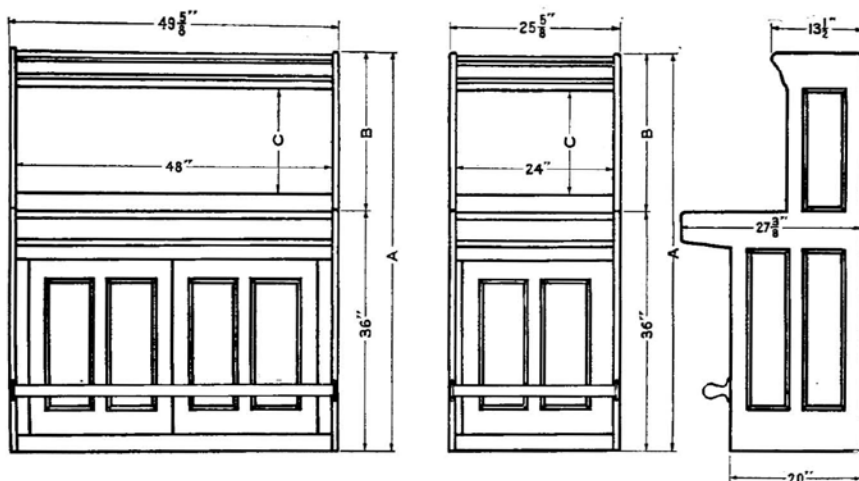

TWO POSITION			
CODE NUMBER OF SWITCHBOARD	A DIMENSION EQUALS	B DIMENSION EQUALS	C DIMENSION EQUALS
1230	60 <sup>5</sup> / <sub>16</sub> "	24 <sup>3</sup> / <sub>16</sub> "	15 <sup>7</sup> / <sub>8</sub> "
1250	67 <sup>11</sup> / <sub>16</sub> "	31 <sup>11</sup> / <sub>16</sub> "	23"

ONE POSITION			
CODE NUMBER OF SWITCHBOARD	A DIMENSION EQUALS	B DIMENSION EQUALS	C DIMENSION EQUALS
1220	60 <sup>3</sup> / <sub>16</sub> "	24 <sup>3</sup> / <sub>16</sub> "	15 <sup>7</sup> / <sub>8</sub> "
1240	67 <sup>11</sup> / <sub>16</sub> "	31 <sup>11</sup> / <sub>16</sub> "	23"

Dimension Diagrams of No. 1200 Type Switchboards

## No. 106B MAGNETO WALL SWITCHBOARD

### Drop Type

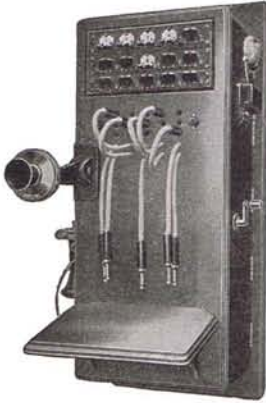

No. 106B Switchboard  
Wall Type

The No. 106B switchboard is intended for exchanges where the total number of lines will not exceed 10.

The cabinet is of richly finished walnut, made to resemble a compact wall type telephone with a hinged front. The switchboard is substantial and will render a high grade of service.

The equipment for each line consists of a 500-ohm drop, bridged across the line, and a jack. These are mounted in the face of the cabinet.

The equipment for answering, originating, and supervising calls consists of four cord circuits with supervisory drop signals, listening jacks and a listening cord.

Equipment for one toll line is also supplied with this switchboard.

The operator's telephone set, furnished with the switchboard, consists of a long distance transmitter and receiver. Other equipment consists of a night alarm circuit, a five-bar hand generator, and a night alarm key.

In operating the switchboard, the operator answers and listens in with either one of the two duplicate listening cords provided for the purpose. Connections are made by means of the other cords without the use of keys. Ringing is done over the listening cord with the hand generator.

### Information for Ordering

Order should call for:

1 No. 106B switchboard equipped for 10 subscriber lines.

## No. 1012 MAGNETO WALL SWITCHBOARD

### Ringer Type

The No. 1012 switchboard is intended primarily for small telephone systems of ten lines or less where it is not feasible to have a regular switchboard operator in attendance.

The cabinet is made of a light finish quarter-sawn oak, having a door hinged in front to facilitate inspection of apparatus and wiring.

Equipment for each line consists of a 1000-ohm ringer. 1600 or 2500 ohm ringers can be furnished if required. Ringer indicators are supplied with each ringer so that the operator, if not in attendance when a bell rings, can tell which line has called.

The equipment for answering and originating calls consists of four cord circuits, listening jacks, and a listening cord. No supervisory or ring-off signals are provided.

The operator's telephone set, furnished with the switchboard, consists of a long distance transmitter and receiver. Other equipment consists of a powerful five-bar hand generator.

In operating the switchboard, the operator answers and listens in with the listening cord and plug provided for the purpose. Connections are made with the other cords without the use of keys. Subscribers are called by ringing with the hand generator through the listening cord.

### Information for Ordering

Order should call for:

1 No. 1012 switchboard equipped for 10 subscriber lines with . . . . ohm ringers.

Telephone Apparatus and Supplies

170

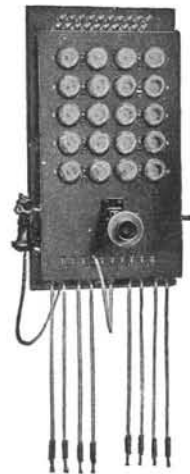

No. 1012 Switchboard  
Wall Type

## PONY MAGNETO SWITCHBOARDS

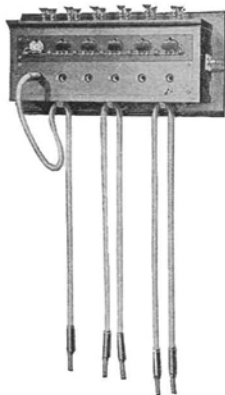

No. 1023 Pony Switchboard

These switchboards are designed for the same class of service as the No. 106B and No. 1012 switchboards. They are simple and inexpensive.

Various sizes are available ranging from 2 to 20 line capacity with connecting cord equipment in proportion to the line equipment.

The Pony switchboards are compactly built of richly finished walnut. Binding posts on top of the cabinet are used to connect in the line wires.

A separate magneto telephone is required for the use of the switchboard attendant.

The board is equipped with a night alarm circuit.

No provision is made for supervisory signals.

Code No.	No. of Lines	No. of Pairs of Connecting Cords
1021	2	1
1022	4	2
1023	6	3
1024	8	4
1025	10	5
1026	12	6
1027	14	7
1028	16	8
1029	18	9
1030	20	10

**Note 1:** The above switchboards can be furnished for use on metallic or grounded lines. Metallic circuit boards are recommended, as they can also be used for grounded lines by grounding one binding post of each grounded line.

**Note 2:** Only the Nos. 1023 and 1025 boards, arranged for metallic circuits, are carried in stock; all others, including the No. 1023 and No. 1025, arranged for grounded circuits, will be made up on order.

### Information for Ordering a Pony Switchboard

Order should call for:

1 No. . . . Pony switchboard for . . . . lines and arranged for . . . . circuit (specify if metallic or grounded circuit).

## No. 1248A AND No. 1258A CENTRAL BATTERY NON-MULTIPLE SWITCHBOARDS

These central battery non-multiple switchboards are designed for serving central battery telephone lines and a small number of magneto lines. With the exception of central battery boards of the multiple type they are the largest made.

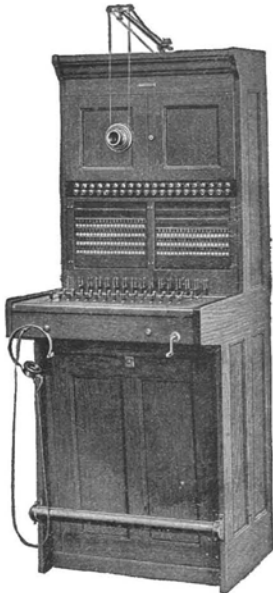

No. 1248A Switchboard

The No. 1248A one-position board is best adapted for use where the number of central battery lines will not exceed 240; the No. 1258A two-position board where the maximum will be 480 lines.

Central battery lines are arranged with lamp signals and relays for controlling the lamps as in the large multiple type boards.

Magneto lines terminate in combined jacks and signals.

Cord circuits are arranged with lamp supervisory signals, giving positive supervision. Any or all cord circuits can be arranged to operate as straight central battery, combination central battery and magneto, or full universal.

In the universal circuits, toroidal type repeating coils will be furnished if specified. When these are furnished, a cut-out key is used so that if two magneto lines are connected, the repeating coil may be either cut in or out of circuit. When a magneto and central battery line are connected, the repeating coil equipment will serve to eliminate noise.

Various ringing combinations are available. To provide for any of these, universal wiring is installed to connect the different types of cord circuit keys.

### Specifications

The condensed specifications applying to the No. 1200 type magneto switchboards and covering frameworks, finish, general equipment, and wiring apply in general to the No. 1248A and No. 1258A switchboards.

Suspended type transmitters are usually furnished, but chest type transmitters will be supplied, if ordered.

The switchboard cabinet is arranged to mount the line relays for the central battery lines in the upper portion. The cord circuit relays are located in the lower portion behind the cords.

Code No.	Positions	Central Battery Line Capacity	Magneto Line Capacity	Cord Circuit Capacity
1248A	1	240	20	15
1258A	2 { left position right position	240 240	20 20	15 15

**Note 1:** The cord circuits have universal wiring and may be equipped as central battery, combination or universal cords as ordered. Toroidal type repeating coils with keys may be provided for any or all cord circuits.

## No. 1248A AND No. 1258A CENTRAL BATTERY NON-MULTIPLE SWITCHBOARDS

### Specifications (Continued)

**Note 2:** At a slight cost any cord circuit arranged for magneto connections may be equipped with the new Flashing Recall feature. This feature provides an automatic and continuous flashing of the lamp supervisory pilot signal on ring-offs or recalls on magneto lines until the signal is answered by the operator. This equipment is described more in detail on page 93.

**Note 3:** Equipment for through toll lines will be furnished if ordered. Each through toll line will occupy the space of two of the combined jacks and signals, and reduces the magneto line capacity correspondingly.

**Note 4:** The universal local cable provides wiring for any of the following ringing combinations:



No. 1258A Switchboard

Single party, one or two-way ringing.

Two-party, one-way, selective individual or selective master.

Two-party, two-way, selective individual or selective master.

Four-party, one or two-way, pulsating master.

Four-party, one or two-way, harmonic individual or harmonic master.

Straight alternating and four-party, one or two-way harmonic master.

Four-party, two-way, harmonic individual or harmonic master.

Straight alternating and eight-party, one or two-way, harmonic master.

Eight-party, one-way, harmonic individual or harmonic master.

Eight-party, two-way, harmonic master.

### Information for Ordering a No. 1248A or No. 1258A Switchboard

Order should call for:

1 No. .... switchboard equipped for .... common battery and .... magneto, subscriber lines and arranged for ..... ringing.

.... subscriber common battery cord circuits.

.... Universal cord circuits with ... repeating coils and cut-out key (coil and key furnished only when specified).

.... through toll lines.

(If the Flashing Recall feature is desired, information should so state.)

## CENTRAL BATTERY MULTIPLE SWITCHBOARDS

Central battery multiple switchboards are designed for use in telephone exchanges serving 1600 to 10500 subscribers.

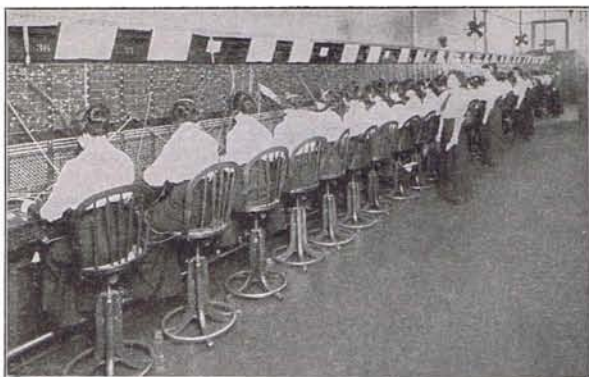

Central Battery Multiple Switchboard at Yonkers, N. Y.

Exchanges of this size necessitate very complete equipments if the highest grade of service is to be given. Boards of the central battery multiple type are, therefore, manufactured to order to conform to the requirements peculiar to each case.

In general, three-position, steel frame, solid mahogany sections are used. The steel frames are rigid and sturdy. The woodwork is thoroughly seasoned and richly finished. All joints are reinforced with steel angle braces. The switchboard sections exhibit the highest quality of workmanship in every part.

Each switchboard requires an end panel at one end and a cable turning section at the other to provide an inclosed space at the point where the cables leave the switchboard to go to the distributing frames.

A separate main distributing frame, relay rack, and power plant are also required. Intermediate distributing frames are often used, particularly in large equipments, but not on installations having the *live* signals directly associated with the multiple jacks.

Desk equipment, that may consist of a chief operator's desk and a wire chief's desk, is usually required. Other desks, such as information desks and manager's desk, are often required and can be furnished when ordered.

The Western Electric Company's enormous production, annually, of multiple central battery switchboards makes it possible to use the best materials that the market affords.

A well-equipped and experienced force of engineers is in readiness at all times to study requirements, furnish traffic study forms, and cooperate in every possible way with telephone companies contemplating the purchase of a switchboard.

## AUTOMATIC FEATURES

### For Central Battery Multiple Switchboards

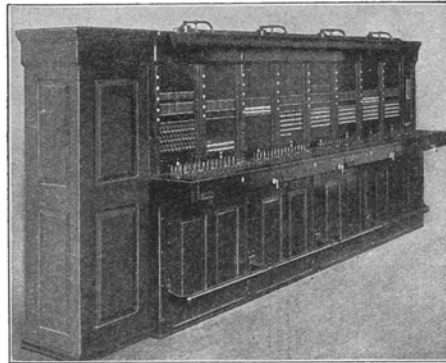

Central Battery Multiple Switchboard, Charles City, Iowa

For use on multiple central battery switchboards, the Western Electric Company offers a number of automatic features for cord circuits that will have the effect of improving service to the telephone-using public, and continuously increase operating efficiency, in most cases 20 to 30 per cent.

Each of these features, by increasing operating efficiency, will effect real economy and increase the telephone company's revenue. More calls can be handled with a fewer number of operators, thus cutting down operating costs.

The principal features that can be supplied with equipments are as follows:

- Automatic listening.
- Automatic ringing.
- Automatic ringing tone to calling subscribers.
- Automatic ringing cut-off on abandoned calls.
- Automatic ringing cut-off by called subscribers the instant a call is answered.
- Automatic flashing recall.
- Automatic call counters.
- Emergency listening.

Local conditions govern, to a great extent, the determination of the features that may be applied to advantage in the case of any one equipment. It is therefore preferred, and to the telephone company's advantage, that a complete study be made to determine what features are needed or those which can best be applied to result in a maximum gain in operating efficiency.

Our engineers are prepared to make extensive studies for any exchange, upon request.

### AUTOMATIC FEATURES

#### For Central Battery Multiple Switchboards

With automatic ringing and automatic listening, operators have a minimum of motions to go through—a great time saver and economy producer under heavy traffic conditions.

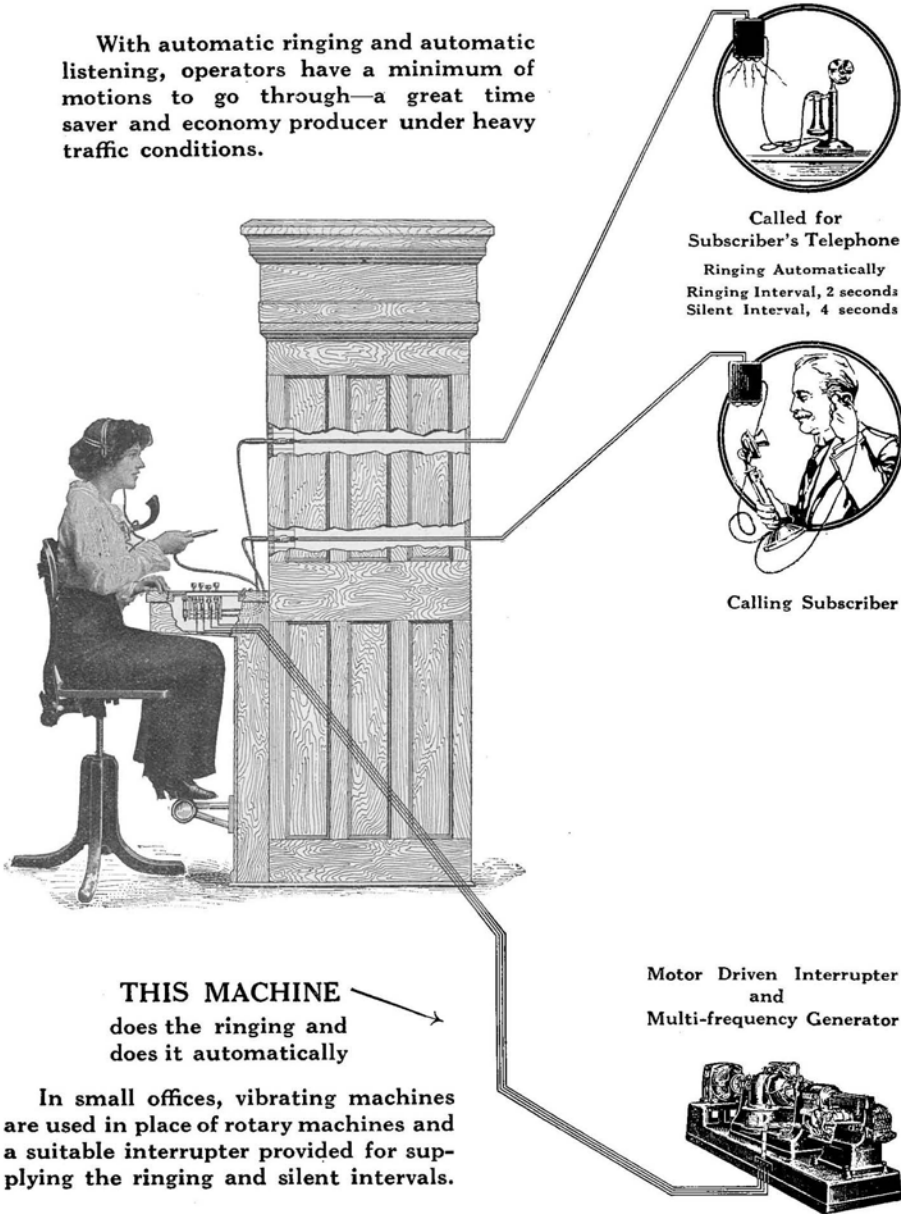

Called for  
Subscriber's Telephone  
Ringing Automatically  
Ringing Interval, 2 seconds  
Silent Interval, 4 seconds

Calling Subscriber

Motor Driven Interrupter  
and  
Multi-frequency Generator

**THIS MACHINE** →  
does the ringing and  
does it automatically

In small offices, vibrating machines are used in place of rotary machines and a suitable interrupter provided for supplying the ringing and silent intervals.

## CONVERTIBLE MULTIPLE SWITCHBOARDS

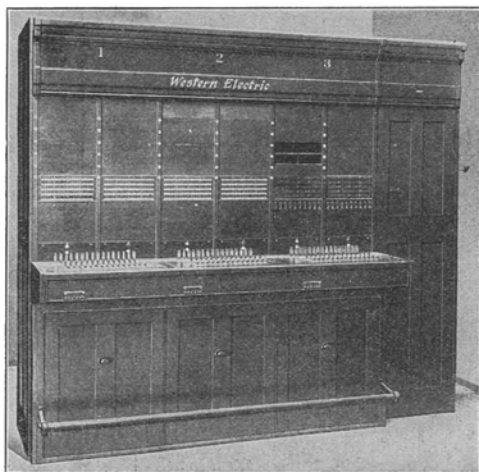

**Typical Convertible Multiple Switchboard**

Convertible multiple switchboards are practically the same as regular common battery multiple equipments.

The wood and steel frameworks, finish, apparatus, wiring, and arrangement are of the same high quality that has made Western Electric apparatus standard equipment for the leading telephone companies throughout the country.

A traffic study will be made upon request to determine the equipment best suited to your needs.

Convertible multiple switchboards have been designed for growing telephone companies who desire to change gradually from operating magneto lines to operating central battery lines.

This type of board makes it possible to introduce central battery operation one line at a time. In place of installing magneto telephones, less expensive central battery instruments can be used. When any line is to be converted, only a slight change in the connections at the line and cut-off relay is necessary. No apparatus need be changed.

The cord circuits differ from those of the central battery multiple board in that they are of the automatic universal type and operate equally well with either magneto or central battery lines.

In appearance and general design, the con-

## MAGNETO MULTIPLE SWITCHBOARDS

The magneto multiple type of switchboard has been designed to produce an equipment for large exchanges operating magneto lines in which there will be a jack for every line within reach of each operator. It is used where local conditions do not warrant central battery operation; but where efficiency of operation can only be obtained with a multiple switchboard.

The magneto multiple board differs from central battery multiple and convertible multiple boards in that combined jacks and signals are used instead of lamp signals and jacks. Separate multiple jacks are used for all lines to enable any operator to establish connections for any subscriber line.

This type of board is also made in what is known as a partial multiple. This consists of a three-position section with the lines terminating in the first position multiplied to the third position, and those in the third position multiplied to those in the first.

Partial multiple boards are adapted to exchanges where the ultimate number of lines will not exceed 600 and where three operators can handle all the traffic.

Frameworks, finish, apparatus, wiring, and arrangement correspond in quality to those of the others in the line of Western Electric switchboards.

Magneto multiple and magneto partial multiple switchboards are made only in capacities of 1200 and 600 lines, respectively.

## TOLL NON-MULTIPLE SWITCHBOARDS

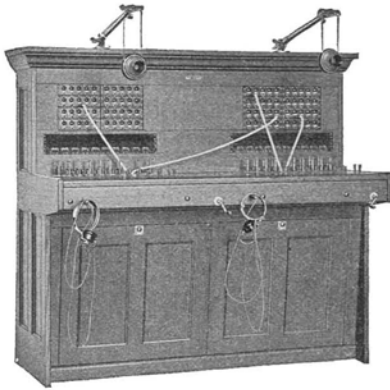

No. 1275  
Toll Non-multiple Switchboard—2 Position Cabinet Type

The difference between toll operating and local line operating makes it advisable to provide a separate toll switchboard where there is considerable toll traffic.

The toll non-multiple boards that are offered are suitable for use with either multiple or non-multiple magneto or central battery local switchboards.

Combined jacks and signals are used throughout for the line equipment.

Incoming trunk lines can be provided to give a means for communication between the local and toll switchboards. If the local board is of the non-multiple magneto type, the incoming trunks terminate in a jack and lamp signal. If the local board is of the central battery type, the incoming trunks terminate in a jack and drop.

Outgoing trunks can also be provided for communicating from the toll board to the local switchboard. The same distinction between trunks from magneto and trunks from central battery boards applies as in the case of incoming trunk circuits.

Recording trunk circuits are available for providing a means whereby local subscribers requesting toll connections can be placed in communication with the recording toll operator. In small toll installations, the toll line operator does the recording work.

Call wire circuits, operating in connection with the outgoing trunks, can be furnished to enable the toll operator to re-establish communication with the calling subscriber, who, due to the length of time needed to establish the long distance connection, has been asked to hang up his receiver until called.

Two types of toll non-multiple switchboards are furnished: the cabinet and desk types. Construction features, apparatus, wiring, and general arrangement are the same as those embodied in the others of the standard Western Electric line.

The high grade of transmission required for good toll service is assured in any of the following equipments:



No. 1325  
Toll Non-multiple Switchboard Desk Type  
Telephone Apparatus and Supplies

## TOLL NON-MULTIPLE SWITCHBOARDS (Continued)

Code No.	Type	Number of Positions	Lines Capacity	Cords Capacity (Notes 2 and 3)	Incoming Trunks Drop Type Capacity	Outgoing Trunks Capacity	Call Wire Circuits Capacity
1265	Cabinet	1	40	10	10	15	4
1275	Cabinet	2 { left	40	10	10	15	4
		{ right	40	10	10	15	4
1305	Desk	1	40	10	10	15	4
1325	Desk	1	40	10	10	15	4
1345	Desk	2 { left	40	10	10	15	4
		{ right	40	10	10	15	4

**Note 1:** The No. 1305 board of the desk type has but one tier of drawers. The No. 1325 board is the same as the No. 1305 except that it has two tiers of drawers.

**Note 2:** Cord circuits are furnished without repeating coils unless the latter are specified on the order. Repeating coils are recommended for use when it is desired to eliminate the noise resulting when a grounded line is connected to a metallic line.

**Note 3:** Cord circuits are furnished with or without "splitting" (two-way cut-off) keys as desired. These keys make it possible for the toll operator to isolate the two parties on the toll line when conversing with either of them.

**Note 4:** The toll switchboards may be equipped with through toll lines (or cut-in stations). Each two through toll lines occupy the space of one strip of five combined jacks and signals and reduce the line capacity accordingly.

### Information for Ordering a Toll Non-multiple Switchboard

Order should call for:

- 1 No. . . . . toll non-multiple switchboard equipped for . . . . . lines.
- . . . . cord circuits without repeating coil.
- . . . . cord circuits with repeating coil.
- . . . . cord circuits with splitting key.
- . . . . incoming trunks.
- . . . . outgoing trunks.
- . . . . recording trunks.
- . . . . call wires.
- . . . . through toll lines.

(Information for ordering should state to what type of local switchboard—magneto or common battery—the toll switchboard is to be connected, and the kind of ringing service employed.)

## TOLL MULTIPLE SWITCHBOARDS

Multiple type toll switchboard equipments are required for the larger toll switching or exchange centers. They are used where a separate toll board and three or more operators at one time are required to care for the large volume of long distance traffic.

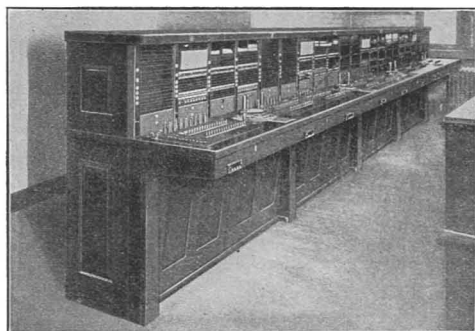

Toll Multiple Switchboard, Lynchburg, Virginia

The great variety of operating requirements makes it necessary to build these toll equipments to order in all cases.

Three general sizes are manufactured, depending upon the size of installation contemplated--the low, intermediate, and high type two-position toll switchboard sections.

These three types have capacities of 150, 300, and 900 toll lines, respectively, with a proportionate capacity for outgoing, trunk-ended jacks.

The intermediate and high type sections are for use only for installations in cities with a large population, such as Cleveland, Detroit, Lincoln, Louisville, Chicago, New York, Philadelphia, Pittsburgh, etc.

The low type of section is intended for cities that have a smaller population.

A high grade of toll service necessitates a high grade of equipment. The severe requirements of this service are met fully in Western Electric toll switchboards. They are in use by leading telephone companies in every part of the country.

We will gladly make a complete study of your toll problems in order that we may recommend an equipment best suited to your particular needs.

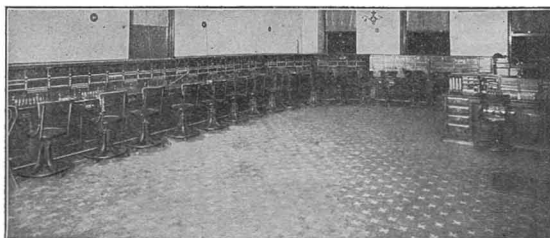

Toll Multiple Switchboard, Syracuse, New York

## No. 1801 CENTRAL BATTERY PRIVATE EXCHANGE SWITCHBOARDS

### Sectional Unit Type

The No. 1801 sectional unit type switchboards have been designed to meet a demand for a small but flexible central battery switchboard suitable for small private exchanges or private branch exchanges, serving from 20 to 60 lines. Equipments having capacities up to 120 lines can also be furnished, if required.

This type of board is constructed along the same lines as the No. 1800 sectional unit type magneto board. They differ in that the No. 1801 has lamps for the line and supervisory signals.

The units of the No. 1801 switchboard are finished in birch, mahogany or light oak. Inside of switchboard units is shellacked to prevent warping. The frameworks are carefully and rigidly assembled. The apparatus is of the same quality as that used in the larger central battery equipments. Wiring is in cable form.

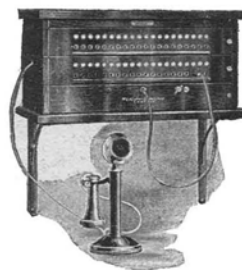

**No. 1801 Switchboard  
Wall Type  
System A**

### Systems

Four different systems—A, B, C and D—have been devised to meet the various classes of service required in this type of switchboard.

#### SYSTEM A

This system provides for communication from outlying stations to one central point only, where an attendant is only required to answer and originate calls. No means are available for connecting two lines together and none for connections to the public telephone system. This system is designed for operation with series, direct current bell type telephones.

#### SYSTEM B

This system provides for communication between stations and between stations and switchboard. No means are available for connecting to the public telephone system. This system is designed for operation with series, direct current bell type telephones.

#### SYSTEM C

This system embodies all the features of systems A and B, and, in addition, provides for connections to a central battery or a magneto central office. This system is designed to operate with series or induction coil direct current bell type telephones. Induction coil telephones are recommended for use with public telephone systems for the best grade of transmission.

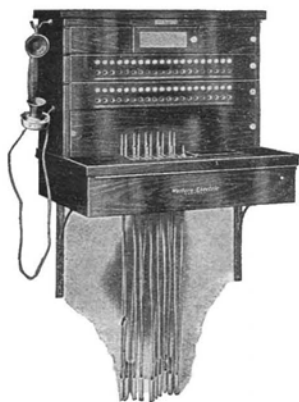

**No. 1801 Switchboard  
Wall Type  
System B, C, or D**

No. 1801 CENTRAL BATTERY PRIVATE EXCHANGE SWITCHBOARDS

Systems (Continued)



No. 1801 Switchboard  
Desk Type  
Systems B, C or D

SYSTEM D

This system provides the same service as System C, except that alternating current is used for ringing the bells at the outlying stations. This makes it possible to use standard central battery telephones with polarized ringers and induction coils.

List of Units

A complete No. 1801 switchboard consists of one supporting unit, one cord unit, one top unit, and one or more line units.

SUPPORTING UNITS

Code No.

- K1 Bracket type support for screwing to a wall (see note).
- K2 Bracket type support, with shelf and casing for cords, arranged for screwing to a wall (see note).
- K3 Desk type with one tier of drawers and with portion of top arranged for mounting the cord unit.

**Note:** System A cord units (later described) are usually mounted on a K1 type support when a wall mounting is desired. Where a wall type support for System B, C and D cord units (later described) is desired, it is customary, but not necessary, to use a K2 type supporting unit which covers up the cords and cord weights by means of a cord casing.

CORD UNITS

System A

Code	Operator's Answering and Calling Cord	Operator's Set Type	Central Battery Lines
JC-1	1	1 hand set	20
JD-1	1	1 desk set	20

**Note:** Of the 20 lines provided in these units, 5 may be arranged for long line service; i.e., lines over 800 feet long, in connection with the line unit HA-2 later described.

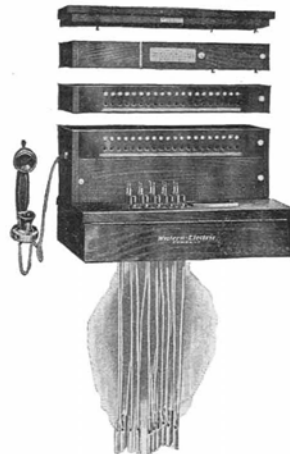

No. 1801 Switchboard  
Showing  
Method of Enlarging

## No. 1801 CENTRAL BATTERY PRIVATE EXCHANGE SWITCHBOARDS

### List of Units

#### CORD UNITS (Continued)

##### System "B"

Code	Connecting Cord Circuits With 1-way Ringing and Listening Keys	Operator's Set Type	Central Battery Lines
JC-2	5	Hand set	20
JD-2	5	Desk stand	20

**Note 1:** Five simultaneous connections may be established by means of the five connecting cords.

**Note 2:** Of the 20 lines provided in these units, 5 may be arranged for long line service with an HA-2 line unit.

##### System C

Code	Connecting Cord Circuits with 1-way Ringing and Listening Keys	Operator's Set Type	Central Battery Lines	Plug Ended Trunks to Central Battery Exchange— Wired	Plug Ended Trunks to Magneto Exchange— Wired
JC-3	5	Hand set	20	2	0
JD-3	5	Desk stand	20	2	0
JC-5	5	Hand set	20	0	2
JD-5	5	Desk stand	20	0	2

**Note 1:** Five simultaneous connections may be established by means of the five connecting cords.

**Note 2:** Of the 20 lines provided in these units, 5 may be arranged for long line service with an HA-2 line unit.

##### System D

Code	Connecting Cord Circuits with 1-way Ringing and Listening Keys	Operator's Set Type	Central Battery Lines	Plug Ended Trunks to Central Battery Exchange— Wired	Plug Ended Trunks to Magneto Exchange— Wired
JC-4	5	Hand set	20	2	0
JD-4	5	Desk stand	20	2	0
JC-6	5	Hand set	20	0	2
JD-6	5	Desk stand	20	0	2
JC-7	5	Hand set	20	0	0
JD-7	5	Desk stand	20	0	0

**Note 1:** Five simultaneous connections may be established by means of the five connecting cords.

**Note 2:** Of the 20 lines provided in these units, 5 may be arranged for long line service with an HA-2 line unit.

#### LINE UNITS

Code No.	No. of Lines Wired (Note 1)	No. of Lines Equipment
HA-1	20	5
HB-1	20	10
HC-1	20	15
HD-1	20	20
HA-2	5 special (note 2)	

**Note 1:** It should be noted that apparatus for 20 line circuits is an integral part of the cord unit equipment. The above line units should be ordered only when a board is required with over 20 lines equipped.

**No. 1801 CENTRAL BATTERY  
PRIVATE EXCHANGE SWITCHBOARDS**

**List of Units**

**LINE UNITS (Continued)**

**Note 2:** The HA-2 line unit is for use in serving 5 long lines in connection with the five regular lines of the cord unit. It is arranged for serving lines that have over 30 ohms resistance. This corresponds to approximately an 800 foot line of No. 22 or a 1600 foot line of No. 19 B.&S. gauge copper wire. The HA-2 unit must be used with another line unit if more than 20 lines are to be served.

**TOP UNITS**

Code No.	Description
G-1	Top unit for use with any combination of units described.

**MISCELLANEOUS UNITS**

Code No.	Description
HB-6	A unit providing facilities for answering all incoming local calls at a given station on the system. This arrangement has proved very desirable with No. 1801 switchboards installed in hotels and industrial establishments where a night clerk or night watchman can most conveniently answer local calls from a station somewhat removed from the switchboard. This unit can be used to operate with systems A, B, C and D.
HA-7	A unit providing for the simultaneous ringing of all stations, and for talking to all stations at one time. This unit can be advantageously arranged to operate only with Systems A, B and C.

**BATTERY SUPPLY**

No. 1801 switchboards require electric current for operation as follows:

System	One Source of 6 Dry Cells in Series for Talking	One Source of 20 Dry Cells in Series (Note 3)	Ringing	No. 22A Hand Generator or No. 62A Interrupter for Ringing
A	Yes	Yes	Yes	No
B	Yes	Yes	Yes	No
C	Yes	Yes	Yes	No
D	Yes } (Note 1)	Yes	No	Yes

**Note 1:** If trunks to a magneto exchange are equipped, 8 instead of 6 dry cells should be used to preserve a high grade of transmission.

**Note 2:** Local conditions frequently justify the use of storage batteries for supplying the current required. If the latter are desired, reference should be made to the descriptive matter covering storage battery plants for telephone exchange use.

**Note 3:** The same string of dry cells is used for ringing and line lamp.

**Information for Ordering a No. 1801 Type Switchboard**

**Operating telephone companies, as a rule, do not permit connections with their wires, switchboards or telephones, of any apparatus or attachments not owned or maintained by them.**

- Order should call for:
- 1 No. . . . . top unit.
  - 1 No. . . . . cord unit.
  - 1 No. . . . . supporting unit.
  - .. No. . . . . line units.
  - .. No. . . . . line units.
  - 1 No. . . . . unit.

No. 1801 CENTRAL BATTERY  
PRIVATE EXCHANGE SWITCHBOARDS  
Dimensions of Units

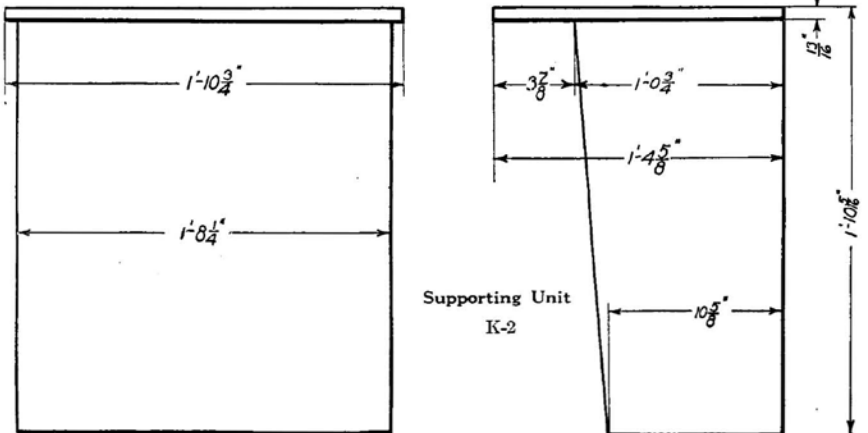
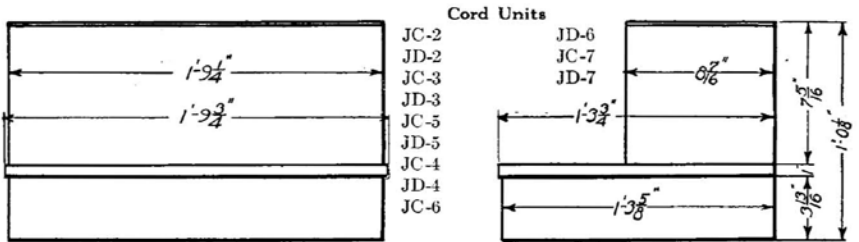
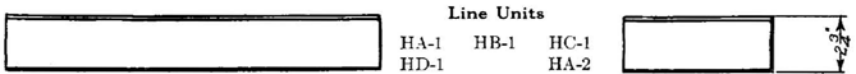
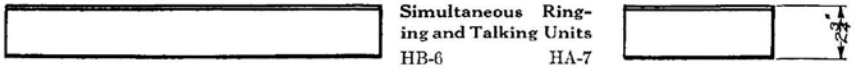
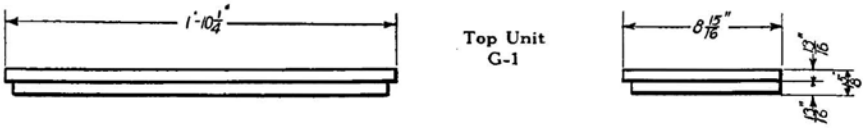
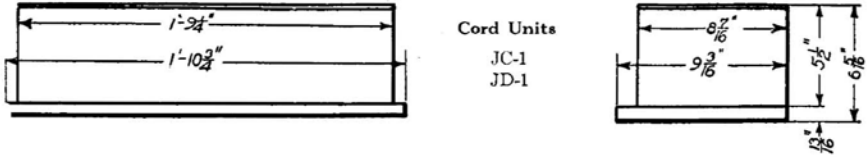

## Nos. 1262-1350 CENTRAL BATTERY P.B.X. SWITCHBOARDS

These switchboards are designed for use as branch exchange equipments connecting with a public telephone system.

They embody, on a small scale, the efficient operating features that are a part of large Western Electric central office equipments. The boards are of the central battery type, making use of lamp line signals and lamp supervisory signals.

This lamp signal type of equipment makes possible rapid and reliable operation. The line signal is associated directly with the corresponding jack so that the operator can plug in directly above the lighted lamp.

Supervision is positive as the signal is closely associated with the corresponding cord.

The current supply may consist of a storage battery at the private branch exchange, charged either over separate conductors or trunks from the central office or from charging equipment at the private branch exchange. It may also be furnished direct from the central office storage battery over a trunk line.

The trunks from the central office terminate in cords and plugs. These plug-ended trunk circuits reduce the number of connecting cords required with the board. The use of one cord instead of two makes for ease in handling and does not tie up the connecting cord circuits. Incoming calls from the central office are completed directly by operator without the use of local cord circuits. This results in increased transmission efficiency.

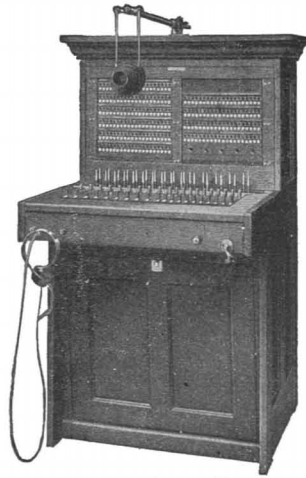

**No. 1262 P.B.X. Switchboard  
Cabinet Type**



**No. 1302 P.B.X. Switchboard Desk Type  
Telephone Apparatus and Supplies**

Holding jack circuits up to the number of five are also provided for each trunk circuit equipped to hold an exchange trunk without tying up a local line. This feature is valuable when the called-for line happens to be busy.

These private branch exchange switchboards are furnished in one and two-position cabinet or desk types.

Cabinet work, finish, apparatus and wiring all conform to Western Electric switchboard standards. The general specifications applying to the construction features of the No. 1200 type, apply to these boards as well.

They can be furnished in either birch, mahogany or oak finish.

## No. 1262-1350 CENTRAL BATTERY P. B. X. SWITCHBOARDS

### Equipment and Capacity Data

Code No.	Type	Number of Positions	Total Line Capacity Wired Including Number Arranged for Relays	Line Relay (Note 2)		Cord Circuit Capacity (Note 3) Number Wired	Plug Ended Trunks (Note 4)	
				Capacity	Wired		Capacity	Wired
1262	Cabinet	1	200	40	20	10	10	5
1272	Cabinet	2	{ L. pos. 200 R. pos. 200	40	20	10	10	5
1280	Cabinet	1	300	40	20	10	10	5
1290	Cabinet	2	{ L. pos. 300 R. pos. 300	40	20	10	10	5
1302	Desk	1	200	30	15	10	10	5
1320	Desk	1	60	30	15	10	10	5
1321	Desk	1	100	30	15	10	10	5
1322	Desk	1	200	30	15	10	10	5
1330	Desk	1	300	30	15	10	10	5
1342	Desk	2	{ L. pos. 200 R. pos. 200	30	15	10	10	5
1350	Desk	2	{ L. pos. 300 R. pos. 300	30	15	10	10	5

**Note 1:** The No. 1302 desk has only one tier of drawers. All others have two tiers of drawers.

**Note 2:** Line relays are necessary where the local lines have over 30 ohms resistance. This corresponds to approximately an 800 foot line of No. 22 or a 1600 foot line of No. 19 B.&S. gauge copper wire.

**Note 3:** Listening and two-way ringing keys are standard for the cord circuits. The cord circuits also have double lamp supervision.

**Note 4:** Plug ended trunks may be equipped for connection to central battery or magneto exchanges. They are provided with listening, ringing, holding and flashing keys. The holding and flashing features can, of course, be used only on trunks to central battery exchanges.

**Note 5:** Suspended type transmitters are standard for this line of boards, but chest type transmitters will be supplied if ordered.

#### BATTERY SUPPLY

These switchboards can be furnished to operate from a 22 or a 40 volt source of battery current. Storage batteries should always be used with boards of the sizes listed, as the use of dry cells or other primary batteries is not an economical proposition.

### For the Information of Customers

**Operating telephone companies, as a rule, do not permit connections with their wires, switchboards or telephones, of any apparatus or attachments not owned or maintained by them.**

### Information for Ordering

Orders should call for:

1 No. .... switchboard finished in ..... and equipped for  
 ..... lines with relays and  
 ..... lines without relays  
 ..... cord circuits  
 ..... plug ended trunks to ..... central office  
 ..... holding jacks

(Ordering information should also state type of transmitter desired; if exchange is to operate on 22 or 40 volts and if trunks are to central battery or magneto central office.)

No. 1262-1350 CENTRAL BATTERY  
P. B. X. SWITCHBOARDS  
Dimension Diagrams

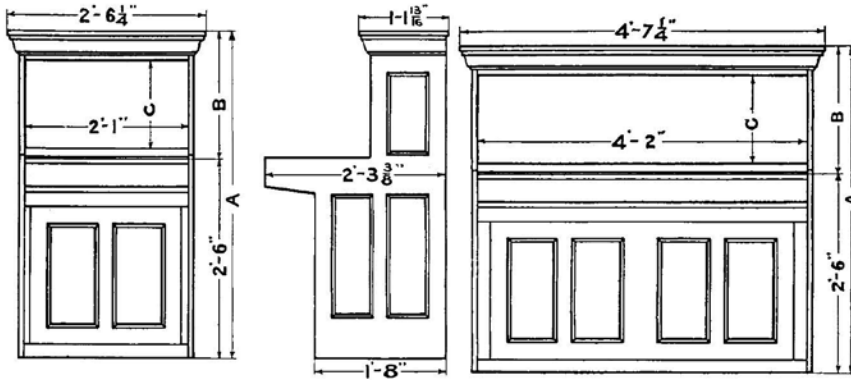

DIMENSIONS OF P. X. SWITCHBOARD CABINET TYPE SINGLE POSITION			
CODE NO. SWITCHBOARD	DIMENSION		
	A	B	C
1262	4'-1"	1'-7"	10 5/8"
1280	4'9 3/8"	2'3 3/8"	16 1/2"

DIMENSIONS OF P. X. SWITCHBOARD CABINET TYPE DOUBLE POSITION			
CODE NO. SWITCHBOARD	DIMENSION		
	A	B	C
1272	4'-1"	1'-7"	10 5/8"
1290	4'9 3/8"	2'3 3/8"	16 1/2"

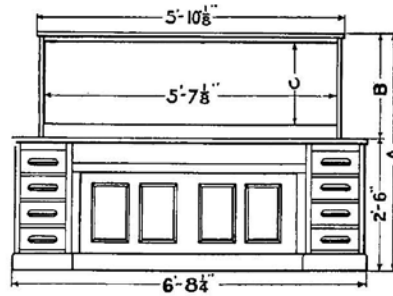
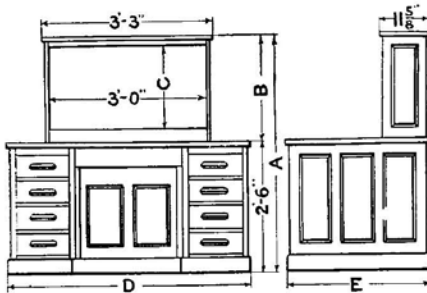

DIMENSIONS OF P. X. SWITCHBOARD DESK TYPE SINGLE POSITION					
CODE NO. SWITCHBOARD	DIMENSION				
	A	B	C	D	E
1302	3'9 7/8"	1'3 3/8"	10 5/8"	3'6 1/4"	2'8 1/2"
1320	3'9 7/8"	1'3 3/8"	10 5/8"	4'6 1/8"	2'8 1/2"
1321	3'9 7/8"	1'3 3/8"	10 5/8"	4'6 1/8"	2'8 1/2"
1322	3'9 7/8"	1'3 3/8"	10 5/8"	4'6 1/8"	2'8 1/2"
1330	4'5 3/4"	1'1 1/2"	16 1/2"	4'6 1/8"	2'8 1/2"

DIMENSIONS OF P. X. SWITCHBOARD DESK TYPE DOUBLE POSITION					
CODE NO. SWITCHBOARD	DIMENSION				
	A	B	C	D	E
1342	3'9 7/8"	1'3 3/8"	—	4'6 1/8"	2'8 1/2"
1350	4'5 3/4"	1'1 1/2"	—	4'6 1/8"	2'8 1/2"

No. 302 Has Only One Tier of Drawers, Which  
Are on the Right Hand Side  
Telephone Apparatus and Supplies

## CORDLESS SWITCHBOARDS

This style of switchboard is designed for central battery and magneto service. It is suitable for use as a private branch exchange as well as a private exchange.

The central battery type usually serves as a private branch exchange switchboard in conjunction with a central battery central office.



No. 505B  
Cordless Switchboard

The magneto type are usually used as private exchanges or private branch exchanges operating in conjunction with a magneto central office.

The central battery cordless switchboard is known as the No. 505B and is arranged for three trunk lines and seven local stations (commonly known as a 3 x 7 cordless switchboard). The magneto board is arranged for ten magneto lines.

It is a small self-contained unit that can be mounted upon an ordinary desk or table. It is a desirable equipment where the operator has other duties to perform, such as stenographic work, clerical work, etc.

Keys are used for establishing connections. This permits of more rapid operation than is possible with cords. Keys also have a longer life than cords and give less trouble.

The keys provide for five simultaneous connections, three to outside parties and two local connections.

The trunks from the central office terminate on drops. This enables central to recall the P.B.X. operator at any time.

Supervision of connections is maintained by means of signal targets that are displayed when the parties have finished talking.

Three keys are mounted on the side of the board. One controls the operation of a night alarm buzzer in connection with the line signals; and another, the supervisory signal buzzer. The third is used as a generator-switching key, so that either ringing current from the central office or from the hand generator may be used.

The operator's telephone consists of a desk set complete with receiver, transmitter and cord.

Standard central battery telephones are used for the No. 505B type board, and standard magneto telephones for the magneto type board.

A stock of the No. 505B type boards is maintained in oak or birch-mahogany finish. Due to the rather limited demand for the magneto type board, they are made on order in either oak or birch mahogany finish.

It is best to obtain battery supply for the No. 505B type central battery board from the telephone central office over spare wires or from an eleven storage cell plant which may be charged over spare wires from the central office. Battery current for the magneto type cordless board may be best obtained from 6 dry cells or other suitable primary batteries (3 cells for telephone circuit and 3 for the buzzer circuit).

### Operation

Below each extension and trunk line signal there is a row of three key levers. The row at the extreme right is for the operator's telephone. Each key lever has three positions—up, normal and down. Throwing the upper lever of any key upward connects the corresponding trunk, extension or operator's set to the No. 1 connecting circuit. Throwing it downward connects the same line to the No. 2 connecting circuit. The middle lever when thrown up or down does the same for connecting circuits Nos. 3 and 4. The upward position of the lower lever connects to the No. 5 connecting circuit.

This will show that when two levers on the same level are in the same position, either up or down, the corresponding lines are connected together.

Thus five different sets of connections are possible by throwing the different levers upward or downward.

The operator rings the extension desired by depressing the lower key lever directly below the corresponding extension signal, if ringing current is furnished from the central office. On magneto lines, or when current is not supplied by the exchange, the hand generator must be turned while this key lever is being depressed.

The operator listens in by throwing one of the key levers at the extreme right of the board into the position corresponding to the connecting circuit into which she wishes to listen. To listen in on a trunk call, she must also operate the corresponding lever below the trunk drops.

When the lower lever of a trunk key is depressed, a holding coil is bridged across the trunk to enable the operator to hold the trunk until the desired connection can be made.

The wiring is so arranged that two trunks cannot be connected together, but any number of extensions can.

### Information for Ordering

Order should call for:

1 No. 505B switchboard finished in . . . . . and for . . . . . service (specify central battery or magneto.)

# Typical Western Electric Telephone Switchboards



Chelsea Exchange,  
New York



Plainfield, N.J.

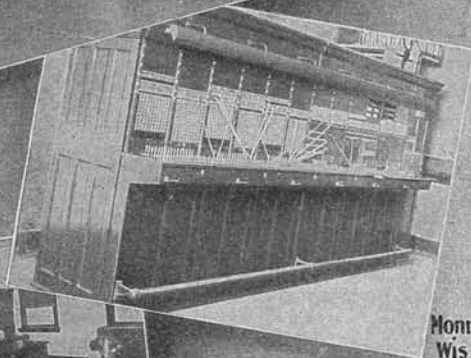

Monroe  
Wis.



Lexington, Mo.

The Western Electric Company  
can supply any type of central  
office equipment from the  
smallest to the largest – to  
meet any condition of service.

# Typical Western Electric Telephone Switchboards



Toll Board  
Lincoln , Neb.



Toll Board  
New York , N.Y.

The Western Electric Company  
can supply common battery,  
convertible magneto multiple  
and other types of non-multiple  
and multiple switchboards.



Toll Board  
Cedar Rapids, Iowa

## *Western Electric* TELEPHONES

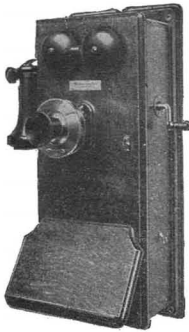

**Magneto Wall Telephone**

There is a Western Electric telephone which will satisfactorily meet any service condition, the telephones listed on the following pages being considered as meeting all usual requirements. For special requirements we have special telephones. Should special conditions be met which are not already covered by existing apparatus, our skilled force of engineers are at your service, and we invite inquiries and correspondence, which will be given immediate and cheerful attention.

Western Electric telephones can be relied upon to give perfect satisfaction. Our valuable and extensive experience in the manufacture of telephone equipment covers a continuous period of more than 38 years, and enables us to offer equipment which has proved its efficiency and reliability under most severe conditions. Through successful design, careful construction and the use of only the best materials and workmanship, Western Electric telephone apparatus has now come to be recognized by the leading telephone authorities throughout the world as standard.

Our large output enables us to purchase raw material under rigid specifications in large quantities at the lowest market prices. This, together with unequalled manufacturing facilities makes it possible for us to offer standard telephones at reasonable prices.

Every telephone, and in fact every part, is subjected to a rigid inspection both in the raw material and during manufacture, as well as before shipment. No expense is spared to make these telephones give perfect service during a long and useful life.

Large and complete stocks are carried in our numerous distributing houses which are located in thirty-two principal cities of the United States and are so situated as to make possible the delivery of goods in most cases within twenty-four hours of the receipt of the order. This system of locating distributing houses in the various commercial centers throughout the country insures prompt filling of orders together with a considerable saving in transportation, as our prices are F. O. B. the distributing houses.



**Magneto Desk Telephone**



**Inter-phone**



**Mine Telephone**



**Central Battery Desk Telephone  
Telephone Apparatus and Supplies**

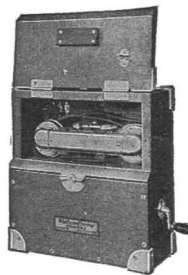

**Portable Railway Telephone  
192**



**Central Battery Wall Telephone**

## TELEPHONE TERMS

### Definitions of Terms—General

The following definitions of terms used in connection with our telephones may be of interest and helpful in selecting the instruments best suited to any condition or requirement.

### Telephone Lines

**GROUNDING LINES** A grounded telephone line or system consists of only one wire, the ground being used for the return circuit, hence the term "grounded line."

Grounded lines give fairly good results when properly installed, provided there are no electric light, power or trolley wires in the vicinity of the telephone line. In this case there is likely to be much objectionable humming and buzzing in the receivers when the line is in use.

**METALLIC LINES** A metallic line is one consisting of two line wires, the ground not being used in this instance to complete the circuit.

Metallic lines under almost every condition are the most satisfactory to build, maintain and operate and are almost universally used, grounded lines being very rarely considered when high class service is desired.

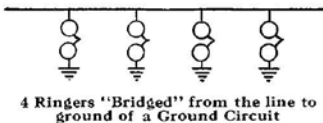

4 Ringers "Bridged" from the line to ground of a Ground Circuit

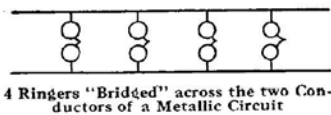

4 Ringers "Bridged" across the two Conductors of a Metallic Circuit

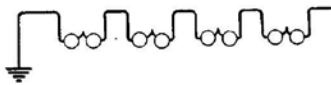

4 Ringers in series with a Grounded Circuit

**BRIDGING LINES** Practically all telephones in present day use are known as bridging telephones. In these telephones the ringers are connected in parallel across the line wires when used on a metallic circuit, or from the single line wire to ground when used on a grounded line.

**SERIES LINES—Magneto** Early in the development of the telephone art, magneto telephones were connected in series—like telegraph instruments are connected in a telegraph line. It was later found, however, that the voice currents by passing through all the ringers connected in the line were quite seriously impeded and lost much of their strength, thus making it impracticable or impossible to telephone over long distances or to place large numbers of telephones on one line and at the same time secure satisfactory service. As mentioned above, nearly all telephones in present day use are bridging, the use of series apparatus being discouraged and only recommended where conditions specifically warrant or require this equipment.

These instruments should not be confused with the Series Central Battery apparatus listed and described under Central Battery Telephones.

### Telephone Systems

There are two general classes of telephone exchange systems in present day use: Magneto (sometimes called local battery) and central battery (sometimes called common battery or central energy). These two systems differ principally in the details of operations, that is, in the method of signaling or calling the other telephones or "central" and in the method of furnishing current for talking.

**MAGNETO SYSTEMS** In magneto systems the telephone user signals or calls the exchange or other telephones on the same line by turning a crank at the side of the telephone, which operates a magneto generator mounted inside, the current thus generated causing a signal to be displayed or sounded at the central office (or exchange) or the bells of the other telephones to ring.

In magneto systems the current for talking is usually furnished by two or three dry cells or batteries, either located inside the telephone itself (in the case of wall telephones) or near by on a shelf or in a battery box.

**CENTRAL BATTERY SYSTEMS** In central battery systems the exchange is signaled by merely lifting the receiver from the hook on the telephone instrument. In these systems the other telephones on the same line cannot be rung except from the exchange.

In central battery systems the batteries, which supply current for talking, as the term implies, are located at the central office or exchange, one large battery usually supplying all the telephones connected to the exchange.

## TELEPHONE TERMS

### Telephone Systems (Continued)

**PRIVATE LINES** These are isolated lines or systems either grounded or metallic which do not come in contact or have any facilities for connecting with other lines for intercommunication, i. e., have no central office or exchange. They may consist of but two instruments connected to each end of the wires or they may have connected several instruments scattered along the line in different locations.

Private lines are principally used by railroads, mines and for farm or rural lines where no connection is possible or desired with other lines through a switchboard or exchange.

Standard bridging magneto telephone instruments are usually employed for private line work, although in the case of railway telephone train dispatching lines, special telephones are used which cannot be classified as either magneto or central battery, these instruments being best described as Railway Train Dispatching Telephones.

Private lines as above described should not be confused with individual or direct lines, later described, which refer to exchange lines equipped with only one telephone.

**INTERCOMMUNICATING SYSTEMS** These systems include a number of lines which usually cover a very limited area, generally within the premises of a single owner or concern. Such systems in general are of an automatic nature, that is, the user performs his own switching by pressing a button or key which rings the bell of the desired station and connects the two lines for talking. No operator is required for these systems and, in fact, no systems requiring a switchboard and attendant are considered under this classification.

As in the case of telephones for a railway train dispatching system, the instruments used in intercommunicating systems do not fall under either the magneto or central battery classification and they are best described and known as intercommunicating telephones. The Western Electric Company's trade name for intercommunicating telephones is "Inter-phone," and on the following pages will be found a very comprehensive listing of this class of equipment, listed under the heading "Inter-phones."

### Exchange Lines

**INDIVIDUAL LINES** An individual or direct line may be either metallic or grounded and has but one telephone instrument connected to it.

**PARTY LINES** A party line is one having two or more telephones connected to it. The number of telephones which can be connected to a party line varies all the way from two to forty or fifty, and depending entirely on the ringing system employed, the character of service desired and the local conditions encountered.

Under the following heading, "Signaling Systems," party lines of different types and capacities are described.

### Signaling Systems

It is doubtful if any branch of the development of the present day telephone system has received as great an amount of attention as the problem of signaling or ringing on party lines.

Individual or direct lines present no ringing difficulties as only one bell is rung when ringing current is sent out over the line from the switchboard. This is not true, however, with party lines, and how to signal or call any one of a number of telephones connected to a party line becomes at once one of the important problems of the design of the telephone apparatus.

**CODE-RINGING NON-SELECTIVE** The most universal method of signaling parties on a magneto telephone line is by code ringing. This method is also occasionally used on central battery lines, but not frequently. In the code ringing system rings of different codes are employed for each telephone, such as two short, three short, one long and a short, two long and two short or other combinations.

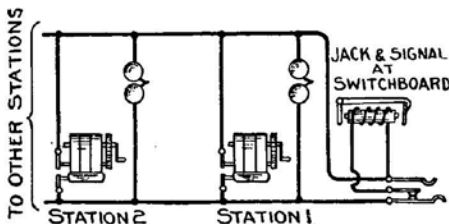

Code Ringing—Magneto Line  
Telephone Apparatus and Supplies

This system has the advantage that it can be used with a large number of telephones on the same line, any number in fact, the number which can be placed on a line depending on conditions other than ringing. Again, it is an economical system, as no special apparatus has to be used for either generator or bells, the only undesirable feature being that when one telephone is called, all the other telephones on the line are also rung, making it necessary for the user to count every signal in order to know when he is being called.

This system is most commonly used on rural or farmer telephone lines.

TELEPHONE TERMS

Signaling Systems—Continued

**SELECTIVE SIGNALING** In order to enable the operator to call the various telephones on a party line a number of methods have been developed whereby the operator can ring the telephones selectively or semi-selectively, as the case may be. Selectively means, of course, that the operator can select and ring any one telephone without disturbing any of the others, semi-selectively meaning that the operator can select and ring any two of the telephones without disturbing the others, code ringing, of course, being employed for selecting out of the two telephones rung the one desired. Telephones arranged for this service can only signal the central office or exchange and cannot call each other without the assistance of the central office operator.

**Individual, 2 Party Selective or 4 Party Semi-selective ALTERNATING CURRENT**

On an individual line the bell is bridged across the two line wires, (in the case of central battery systems a condenser is connected in series with the bell). On a two-party selective line one bell is connected from each side of the line to ground, and on a four-party semi-selective line two bells are connected from each side of the line to ground, the switchboard at the central office being so arranged that by means of a key, current can be sent out over either side of the line through the bells connected to that side of the line to ground. (This class of ringing is often referred to as "divided circuit ringing." On central battery systems a condenser is also connected in series with the bells to ground.)

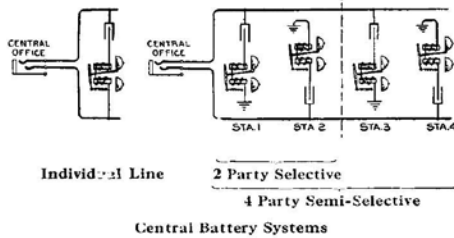

Telephones arranged for this service can only signal the central office and cannot call each other without the assistance of the central office operator.

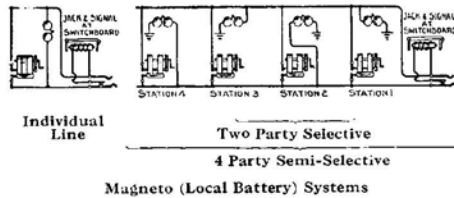

**HARMONIC, 4 and 8 Party Selective or 16 Party Semi-selective**

The telephones used with this system are equipped with special ringers or bells which are made to ring only when alternating current of a given frequency is sent over the line. The frequencies employed are 16 2/3, 33 1/3, 50 and 66 2/3 cycles.

On a four-party selective line the ringers of each

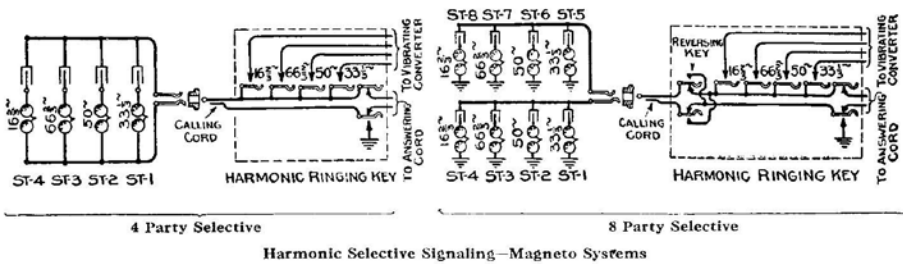

Harmonic Selective Signaling—Magneto Systems

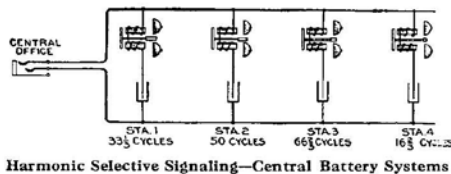

telephone are bridged across the two line wires, on an eight-party selective line four ringers are connected between each side of the line and ground, and on a sixteen-party semi-selective line the ringers are connected between line and ground, eight from each line wire (in this system a condenser is connected in series with each ringer).

Telephone Apparatus and Supplies

TELEPHONE TERMS

Signaling Systems—Continued

4 PARTY SELECTIVE (Magneto Systems)  
—Pulsating Current.

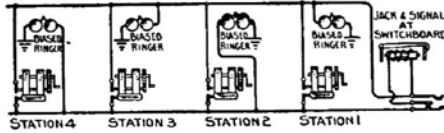

Pulsating Current 4 Party Selective Signaling—Magneto Systems

side. Two of these ringers are connected to each side of the line and so connected that one will respond to positive and the other to negative pulsating current.

4-PARTY SELECTIVE (Central Battery Systems)  
—Pulsating or Superimposed Current

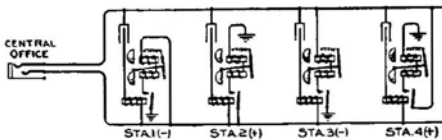

Pulsating Superimposed 4 party Selective Signaling Central Battery System

ically grounded by the operation of the switchboard key. This in turn closes up the four relay contacts and one of the two bells connected to the line over which the current is passing will respond.

The pulsating selective signaling system answers the same requirements as the harmonic selective system, namely: being able to ring any one of four telephones on the same line without ringing any of the other telephones. This system is worked out by sending a positive or negative pulsating current out over either side of the line to ground.

The ringers of the telephones used in this service are biased, i.e., the ringers have a spring on the armature which tends to hold it to one

In Central Battery systems each of the four telephones is equipped with a high impedance relay which is bridged across the two line wires in series with a condenser, and two biased ringers are connected from either side of the line to ground through the contacts of the relays when the latter are operated.

When pulsating or superimposed current of either polarity is sent out over one side of the line to ground, the other side of the line is automatic-

## MAGNETO TELEPHONES

### Definitions of Terms

The following definitions refer to terms used on the following pages in connection with our magneto telephones.

#### SERVICE

The number of telephones that can be connected on the same line varies, ranging from 1 to 40 or more. However, a line having more than 20 or 30 telephones connected is usually very unsatisfactory from a service standpoint, except in case of necessity or for temporary service. The reason for this being that a line carrying so many instruments is bound to be in use almost continuously, the bells ringing at very frequent intervals and the user almost sure to be "rung in the ear" or otherwise interrupted during the conversation.

The following definitions of what may be considered a lightly loaded, medium or heavily loaded line are submitted with the thought that its limits are conservative enough so that under all but extreme conditions the figures given can be relied upon. On the following pages will be found a complete catalog of telephones and opposite the listing of each type is specified the kind of loaded line upon which the particular telephone will give best service. Telephones should never be used on lines loaded heavier than indicated as the maximum for each type.

The telephone lines referred to are assumed to be well insulated and free from high resistance joints.

**Light Loaded Lines** A light loaded line is one of less than 15 miles in length and not equipped with more than 12 telephones.

**Medium Loaded Lines** A medium loaded line is one between 10 and 30 miles long and equipped with from 10 to 30 telephones.

**Heavy Loaded Lines** A heavy loaded line is one up to 40 or 50 miles long or equipped with up to 40 telephones. Lines loaded with this number of telephones are rapidly going out of use and being broken up into shorter lines with fewer number of telephones. Lines of this length or loaded with this great number of telephones should be discouraged in all cases except as before stated, in cases of extreme necessity or for temporary service.

#### CENTRAL OFFICE SELECTIVE SIGNALING

Telephones for this service are so wired that the switchboard drop or signal is operated without ringing the bells of any of the other telephones on the same line by pressing a button while turning the generator crank.

We are prepared to furnish three different telephones, each equipped with a different type of push button which perform similar service, but in a slightly different manner, the results, however, being much the same.

**Using No. 1006A Push Button** Operating this push button connects the generator to one side of the line and to the ground. These telephones can be used only on metallic lines and where the switchboard drop is single wound and has one terminal of its winding connected (or arranged for connecting) to ground. When the generator is operated without pressing the push button, all the other

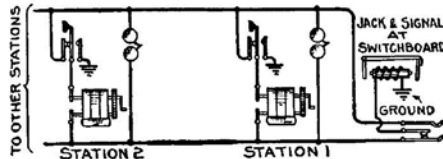

Wiring of Telephones and Switchboard Apparatus when No. 1006A Push Buttons Are Used

telephones on the line are rung without operating the drop at the exchange. When the push button is pressed while turning the generator crank, the drop is thrown, but none of the other telephone bells on the line are rung. This makes it possible to "call central secretly."

**Using No. 1002A Push Button** Operating this push button connects the generator to both sides of the line and to the ground. Telephones equipped with this push button are used where a special double wound drop, having the middle of its winding brought out to a terminal which is connected to the ground, is mounted in the switchboard.

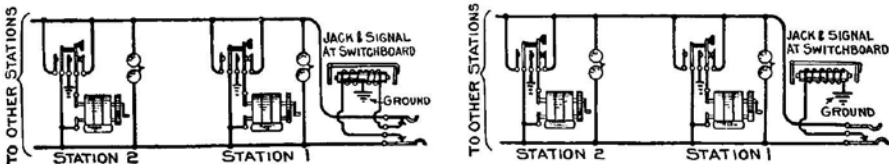

Double Wound Drop Wiring of Telephones and Switchboard Apparatus When No. 1002A Push Buttons Are Used

Telephones equipped with this push button can also be used where the switchboard is equipped with regular single wound drops one side of which is (or can be) connected to ground. When so used, it is not necessary to watch which way the line wires are connected to the telephone, as this push button connects one side of the generator to both sides of the line, and the other to ground.

The operation of this telephone is the same as those equipped with No. 1006A push buttons above described.

## MAGNETO TELEPHONES

### DEFINITIONS OF TERMS

#### Signaling Central Secretly

##### Using No. 1004A Push Button and Pulsating Current Generator

In addition to the push button these telephones are equipped with a special generator, which delivers both pulsating and alternating current. Operating the push button while turning the generator crank throws pulsating current out over the line, which operates the switchboard drop without ringing the other telephone bells connected to the line. In order to operate this system satisfactorily all the telephones

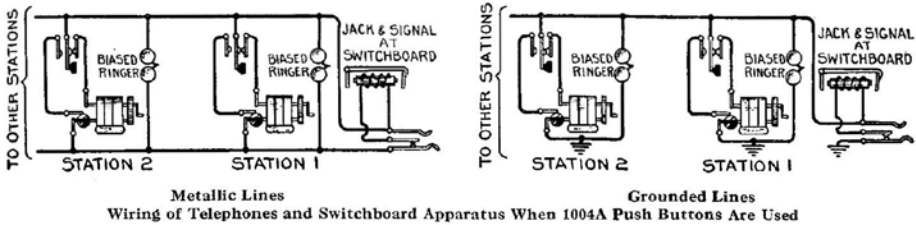

on the line must be equipped with biased ringers and so connected as to have the armature biasing spring pulling in the same direction as the direction of the pulsating current flow, thus preventing their "tapping" when "central" is rung.

When the generator is operated without pressing the push button it sends out alternating current over the line which rings all the telephone bells on the line and also operates the switchboard drop or signal.

With this equipment "central" is signaled on every call, secretly or not, as desired.

#### CENTER CHECKING

Telephones arranged for this service are equipped with a special generator which delivers pulsating current only, and standard alternating current ringers. When the generator is operated central is signaled secretly, that is, none of the other telephone bells on the line are rung. When it is

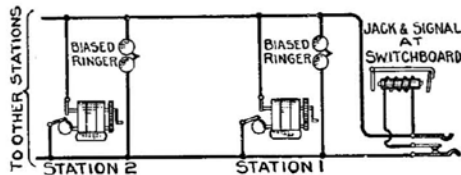

Wiring of Telephones for Center Checking Service

desired to call any other telephone on the line it is necessary to call the central operator and ask to have the telephone desired rung. This scheme gives the central operator control over the line and prevents calls being made without her knowledge. This is sometimes desirable when the telephone is connected to a toll or pay station line running between two exchanges located in different districts, where the calls should all go to one exchange and not to the other.

#### CONDENSERS

On rural lines, trouble sometimes occurs due to parties "listening in" whenever their bells ring, regardless of whether the call is for them or not. Whenever this is done, it is usually impossible to ring on the line after the receiver is off the hook. To overcome this, it is customary to furnish telephones equipped with a condenser wired in the receiver circuit.

All No. 1317 and No. 1305 wall telephones and corresponding desk telephones, arranged for code ringing, have terminals provided so that a condenser can be connected in at any time, and certain types of the No. 1317 telephones are furnished equipped with a condenser as standard.

## MAGNETO TELEPHONES

## No. 1317 Type

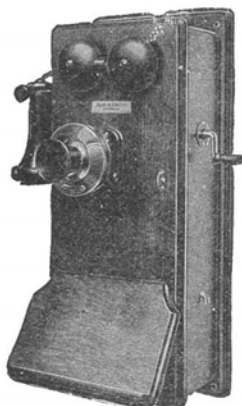

No. 1317C Type (2 Cell)  
Magneto Telephone



No. 1317 (3 Cell)  
Magneto Telephone

## General

The No. 1317 wall type magneto telephones listed herein represent the highest development yet attained in magneto telephone design and construction.

This result is due to the exceptional engineering skill employed and to our forty years' experience in the manufacture of telephones and telephone apparatus, which has enabled us to produce an instrument simple, yet pleasing in design, compact, yet with every part accessible for instant inspection, rugged, yet light in weight and more efficient than any other magneto telephone on the market.

## Cabinet and Assembly

**Finish and Appearance** The design of this telephone is such that it is simple and pleasing in appearance, the dimensions being of good proportion and a durable high polished, hand rubbed finish is given the woodwork, which adds greatly to the appearance, while the interior of the cabinet is also given a protective finish.

**Woodwork** Carefully quarter-sawed oak is used and the construction is strong and durable. All joints are tongued and grooved, the best quality of glue being used. The backboard is slotted its full length to permit the telephone wires entering either from the bottom or top of the instrument.

**Compactness and Accessibility** These telephones are constructed with the aim of producing an instrument which will occupy a minimum of wall space yet with every part easily accessible for inspection.

**Door** The door is plain without paneling, thus permitting a better finish, and is hinged at the left by three electro-galvanized hinges so that when opened the operation of the ringer and generator can be observed while the generator crank is turned, without inconvenience and scratching of the door finish, which is likely to be the case when the door is hinged at the right side. The door is locked when closed by a self-centering screw of substantial design.

**Wiring** All interior wire is in cable form, the conductors in this way being rendered less liable to damage and at the same time making a much neater appearance.

Connections between the apparatus on the door and in the cabinet are made by means of a flexible cable. This obviates the necessity for soldered connections and minimizes the chances for trouble. The cable is held in place by a steel wire spiral.

The main binding posts are inside the cabinet, thus preventing tampering with the connections, accidental short circuits, etc. All terminals including those for the transmitter and receiver cords are screw terminals, and are plainly marked so that there can be no possible mistake when making connections or tests. The various cords, such as those for the transmitter or receiver, and the flexible leads running to the condenser, ringer and battery are all furnished with cord tips.

**Miscellaneous** Each telephone is equipped with a directory hook and the four mounting screw holes are bushed with metal sleeves, thus enabling the installer to put up or take down an instrument without marring the woodwork. A complete and explanatory circuit label or wiring diagram is also pasted on the inside of the door of each telephone.

## MAGNETO TELEPHONES

## No. 1317 Type

## Transmitters

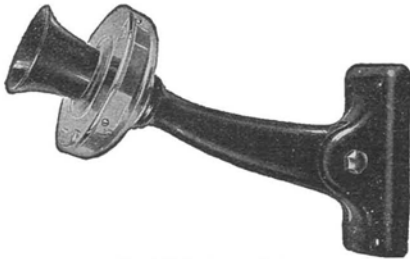

No. 350W Transmitter

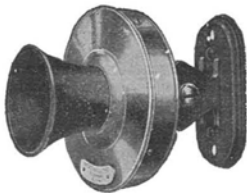
No. 329W Transmitter  
With No. 8A Transmitter BracketNo. 143AW Receiver  
Equipped With Cord  
Telephone Apparatus and Supplies

The transmitters furnished with these telephones are of the most advanced and efficient design and are recognized as standard throughout the world by leading telephone authorities for the longest toll lines as well as short local lines.

Western Electric transmitters are carefully manufactured, every detail being as carefully worked out as those of the finest watch. They have maximum efficiency, are practically indestructible, maintain perfect adjustment throughout life, do not "pack," "burn," or "sputter," consume a minimum amount of current and work equally well in local battery (magneto) or central battery systems.

All exposed metal parts are insulated from the current carrying parts. The diaphragms are made of aluminum which respond readily to sound vibrations, and the face plates are made extra heavy to prevent excessive vibrations and microphonic overtones.

## Receivers

The receivers are scientifically correct in design and are manufactured to give maximum efficiency, long life and to maintain permanent adjustment. A special grade of steel is used in the manufacture of the permanent magnets, enabling them to retain their full strength indefinitely. They respond readily to every variation of the voice currents and faithfully reproduce every spoken word and every voice modulation with full volume and perfect articulation. The spool cores which form the pole pieces are made of specially annealed Norway iron. The permanent magnets and spool cores are electrically welded together forming a perfect magnetic circuit and producing maximum efficiency. The ends of the electro-magnetic cores are absolutely smooth and are lacquered to protect them from rust. The cup or recess back of the diaphragm is made airtight, thus preventing dust from accumulating, or local exterior noises from interfering with the vibrations of the diaphragm, this air chamber also having the effect of damping or cushioning the diaphragm. The shell and cap are smooth and highly polished. The cord hole has a rounded edge which prevents wearing of the cord, and all cord terminals are concealed within the shell. The ear cap is scientifically designed to perfectly fit the orifice of the ear and has no objectionable raised lettering around the rim.

200

## MAGNETO TELEPHONES

### No. 1317 Type

#### Induction Coils

The relation of the windings of the induction coil is such that maximum transmission and efficiency is secured on either long or short lines. The terminals are firmly fastened to the spool heads and so located that the ends of the coils which are fastened to them are not liable to be broken off. The spool heads are amply large and securely held in place. Specially prepared iron is used for the cores of these induction coils which has been selected after years of painstaking research.

#### Switchhooks

The switchhooks used are simple, compact and self-contained. The base, or frame work, has a channel construction which assures rigidity with light weight. The springs are of heavy German silver backed by brass stop springs, insuring positive operation and maximum contact pressure, and are mounted vertically to prevent accumulation of dust on the contacts. A hard rubber roller is provided on the end of the switchhook which rests against the master spring, the latter being adjusted to the proper tension, thus eliminating friction. All of the current carrying parts are well insulated from the frame and all terminals are easily accessible.

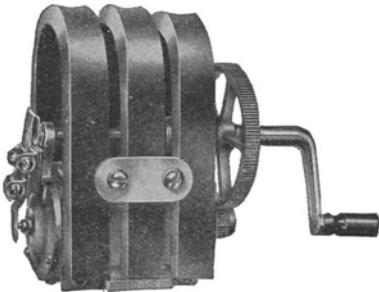

No. 22 Type Generator

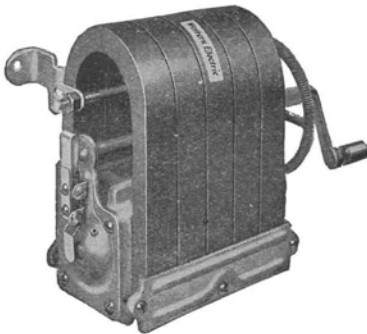

No. 48 Type Generator

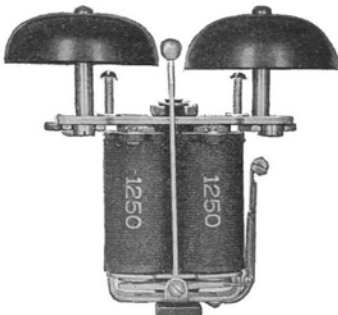

Ringer

#### Generator

The generators used in these telephones are substantially constructed with large bearings for the revolving parts. The armatures are wound with black enamel covered wire, making them moisture-proof, and when not in motion the terminals are either short circuited or disconnected from the line in order to provide complete protection against possible damage from lightning, which may break through the instrument protectors. The act of turning the crank automatically connects the generator to the line and the circuit is automatically broken as soon as the crank is released. The magnets are made of special steel and specially hardened to insure their magnetic strength indefinitely. The crank is made in one piece to give it the necessary strength to withstand rough handling. An oil tube is provided in order that the bearings can be easily oiled when necessary. The gear wheels are carefully cut and finished, which makes possible smooth and noiseless running without appreciable wear.

Generators having 2, 3 or 5 bars with consequent varying strength are furnished for different service conditions. They are the most powerful generators of their type on the market, the No. 50 3 bar generator being the best 3 bar generator yet produced, and, in fact, will ring more bells than many 4 or 5 bar generators.

#### Ringers and Gongs

The ringers furnished with these telephones have specially loud, clear tones and operate on a minimum amount of current and at the same time offer a very high impedance to voice currents. The ringer coils are wound with black enamel wire, which produces more effective ampere turns than a silk insulated wire. This wire also makes the ringer impervious to moisture. The ringer terminals have screw connections and the resistance or impedance is plainly marked. Both the gongs and armature may be easily and accurately adjusted, a screw driver being the only tool needed.

The gongs are black finish and have slotted holes which prevent them from turning on the gong posts and becoming loose. Both 2½ and 3 inch gongs are used, depending on the particular design and construction of the individual telephone.

Western Electric ringers are made in a variety of resistances and frequencies and can be furnished to work satisfactorily on any line with ringers of other manufacture. These ringers are attached to the instrument cabinet by two screws, which can be easily removed when desired.

## MAGNETO TELEPHONES No. 1317-C Type (2 Cell)

Backboard grooved for entrance of line wires at top or bottom.

Switch hook is compact, strong and durable. Finished in durable black.

Receiving efficiency is unsurpassed. Receiver strong and durable. Fits the ear.

Cabinet of solid quarter sawed oak, substantially made. Attractive design.

Writing-shelf placed at convenient and comfortable angle, securely fastened and supported.

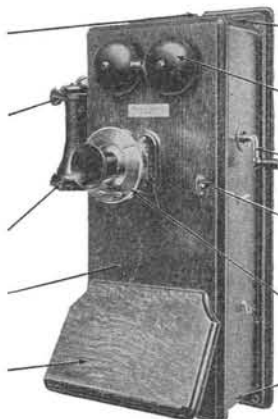

No outside binding posts.

The 2½ inch brass gongs give a loud, clear tone. Finished in black.

One-piece generator crank. Finished in black.

Special self-adjusting lock.

High efficiency transmitter with low battery consumption. Mounted on substantial black enameled bracket, securely fastened to cabinet.

All corners dovetailed and glued.

The new No. 1317C type magneto telephone is the result of a demand by many of our customers for a more compact type of telephone. The principal features of this new type telephone are as follows:

1. It is more compact, smaller and more pleasing in appearance than any telephone of this type.
2. The writing shelf is placed on a more perpendicular angle, which makes it more convenient for writing and also decreases the over-all outside depth of the cabinet. This also makes it impossible for the user to lean on the shelf hard enough to pull the instrument from its fastenings.
3. A short black finished transmitter bracket is provided.
4. Telephones of this type are shipped with the transmitter and writing shelf assembled and attached. Even with these parts attached, the shipping box is approximately the same size as the box used to ship the larger type instruments, which are furnished with the transmitter and writing shelf detached.
5. The new C type has been designed with a battery compartment only large enough to accommodate two cells, thus making possible a smaller and neater cabinet.
6. The No. 50 type 3 bar generator furnished with all C type telephones recommended for moderate and heavy loaded service is exceptionally efficient and powerful, it being capable of giving satisfactory ringing service over at least 95 per cent. of existing magneto lines now in use; for example, this generator will ring at least thirty 2500 ohm ringers connected on a No. 12B.B. iron metallic telephone line, 15 miles in length, assuming, of course, that the line is in good electrical condition, that is, if it is properly insulated and free from high resistance joints. This generator will operate more telephones on one line than many of the 4 and 5 bar generators now in the field. For other use, as indicated in the following listings, our well known No. 22 type 3 bar generator is employed, the service in these cases requiring that a generator which is not so powerful be used.
7. The transmitter bracket, gongs, switchhook, generator handle and lock escutcheon are given a permanent and pleasing black finish, which prevents tarnishing of the metal parts, which is the case when these parts are nickel plated.

Terminals have screw connections. A screw-driver only tool necessary to install and maintain.

Complete wiring diagram showing color and location of every wire.

Door is hinged at left, permitting full view of all operating parts when turning generator.

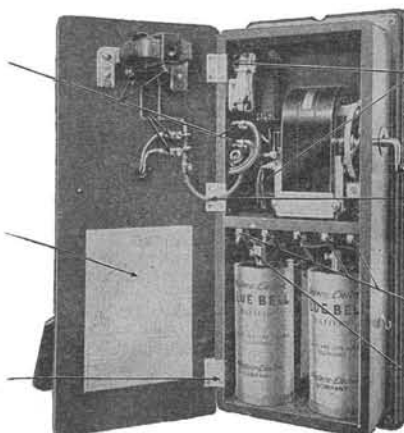

All interior wiring insulated and in cable form. No wires run in slots in back of cabinet.

Flexible armored cable connects apparatus on door and in interior.

Terminals have screw connections. All permanent connections soldered.

Battery terminals extend from cable.

## MAGNETO TELEPHONES

## No. 1317C (2 Cell) Type—Continued

**CENTRAL OFFICE SELECTIVE SIGNALING** Bridging code ringing telephones not listed as equipped with a push button for the above service can be so arranged by ordering a No. 465D key, which is intended for mounting on the side of the telephone and which can be easily wired into the circuit to perform the same function as the telephone equipped with No. 1006A push buttons described on the preceding page.

The No. 1317C type telephones, in addition to the apparatus listed below, are equipped with our standard long distance transmitter, concealed binding post receiver, induction coil, and all necessary cords.

Those telephones for use in harmonic systems are equipped with a 1 Mf. condenser wired in series with the ringer. All other telephones of this type are arranged for a 1 Mf. condenser which may be connected in series with either the receiver or ringer as desired, but with the exceptions indicated below condensers are not furnished unless specified in the order.

**Two Blue Bell Batteries and One No. 60A Protector Are Furnished with Each of the Following Listed Telephones and Are Included in the Price**

**Note:** If batteries are not desired, deduct 60 cents from the list price.  
If protector is not desired, deduct 50 cents from the list price.

## SERVICE DATA AND LIST PRICES

Code No.	Ringer Resistance Ohms	Generator	Push Button	Con-denser	Service	†List Price Each
<b>RINGERS OPERATED BY ALTERNATING CURRENT</b>						
Code Ringing						
1317CN	1600	50 type (3 bar A.C.)	.....	.....	Medium loaded lines	\$22.50
1317CR	1600	50 type (3 bar A.C.)	.....	1 Mf.	Medium loaded lines	23.50
1317CP	2500	50 type (3 bar A.C.)	.....	.....	Heavy loaded lines	23.00
1317CS	2500	50 type (3 bar A.C.)	.....	1 Mf.	Heavy loaded lines	23.90
1317CH	1000	22 type (3 bar A.C.)	.....	.....	Light loaded lines	20.50
1317CG	1000	50 type (3 bar A.C.)	.....	.....	Light loaded lines	22.10
1317CA	1600	50 type (3 bar A.C.)	1006A	.....	Central office selective signaling	23.00
1317CB	2500	50 type (3 bar A.C.)	1006A	.....	Central office selective signaling	23.40
1317CE	1600	50 type (3 bar A.C.)	1002A	.....	Central office selective signaling	23.20
1317CT	1600 (biased)	50 type (3 bar A.C. and pulsating)	1004A	.....	Signaling central secretly	23.60
1317CU	2500 (biased)	22 type (3 bar pulsating)	.....	.....	Center checking	22.10
1317CK	2500 (biased)	50 type (3 bar pulsating)	.....	.....	Center checking	23.80

## RINGERS OPERATED BY PULSATING CURRENT

## Four-party Selective Signaling

1317CJ	2500 (biased)	22 type (3 bar A.C.)			Any one of four parties	\$22.10
--------	---------------	----------------------	--	--	-------------------------	---------

## RINGERS OPERATED BY HARMONIC CURRENT

## Four or Eight-party Selective, Sixteen-party Semi-selective Signaling

Code No.	Ringer	Frequency (Cycles)	Generator	Condenser	Service	†List Price Each
1317CHA	41 type	16 $\frac{2}{3}$	22 type (3 bar *)	1 Mf.	Harmonic selective signaling lines only	\$23.70
1317CHB	41 type	33 $\frac{1}{3}$	22 type (3 bar *)	1 Mf.		23.70
1317CHC	41 type	50	22 type (3 bar *)	1 Mf.		23.70
1317CHD	41 type	66 $\frac{2}{3}$	22 type (3 bar *)	1 Mf.		23.70

\*Arranged to give alternating current, but contact springs are arranged so that approximately one impulse of current out of four is sent over the line.

†These prices include furnishing a No. 143AW composition shell receiver. If the No. 144AW hard rubber shell receiver is required add 50 cents to the list price of each telephone to be so equipped.

Instructions for installing will be furnished on request.

**MAGNETO TELEPHONES**

**No. 1317 (3 Cell) Type**



No. 1317N

The No. 1317 wall telephones listed below are equipped with our standard long distance transmitter, concealed binding post hand receiver and cord, induction coil, and two battery connecting cords.

All of these telephones are wired for a 1 m.f. condenser to be inserted in the receiver circuit. If condensers are desired, however, it should be so stated in the order excepting in the case of the No. 1317R and No. 1317S telephones, which are furnished equipped with a condenser as standard. This equipment should not be confused with the telephones for harmonic ringing service, which are furnished equipped with a 1 m.f. condenser wired in the ringer circuit.

The battery compartments in these telephones provide space for three standard 2½ x 6 ins. dry cells. This number is recommended and usually employed on extremely long distance connection or under severe service conditions where maximum obtainable transmission is absolutely necessary. However, for local exchange and moderate toll service two standard Blue Bell dry cells have been found entirely satisfactory.

**Two Blue Bell Batteries and One No. 60A Protector Are Furnished with Each Telephone and Are Included in the Price**

**Note:** If batteries are not desired, deduct 60 cents from the list price. If protector is not desired, deduct 50 cents from the list price.

**SERVICE DATA AND LIST PRICES**

Code No.	Ringer Resistance Ohms	Generator	Con-denser	Service	*List Price Each
<b>RINGERS OPERATED BY ALTERNATING CURRENT</b>					
(Code Ringing)					
†1317N	1600	48 type (5 bar A.C.)	.....	Medium loaded lines	\$24.10
†1317P	2500	48 type (5 bar A.C.)	.....	Heavy loaded lines	24.50
†1317R	1600	48 type (5 bar A.C.)	21 type	Medium loaded lines	25.10
†1317S	2500	48 type (5 bar A.C.)	21 type	Heavy loaded lines	25.40
†1317AH	1000	22 type (3 bar A.C.)	.....	Light loaded lines	20.50
1317AK	2500 (biased)	48 type (5 bar pulsating)	.....	Center checking	26.20

**RINGERS (BIASED) OPERATED BY PULSATING CURRENT**

**Four-party Selective Signaling**

1317BS	(a)	22 type (2 bar A.C.)	Any one of four parties	\$22.10
--------	-----	----------------------	-------------------------	---------

(a) The ringer furnished with this telephone has an inductive winding of approximately 1000 ohms and a non-inductive winding of approximately 3000 ohms, wound over the inductive winding of the spool. These two windings are connected in series and the junction brought out to an extra terminal for use in connecting an extension instrument or bell.

\*These prices include furnishing a No. 143AW composition shell receiver. If the No. 144AW hard rubber shell receiver is required, add 50 cents to the list price of each telephone to be so equipped.

†These code ringing telephones can be arranged for "Central office selective signaling," by ordering a No. 465D key for each telephone to be so equipped. These keys are intended for mounting on the side of the telephones and can be easily wired into the circuit to perform the same function as telephones equipped with No. 1006A push buttons described on a preceding page.



No. 1317N

Telephone Apparatus and Supplies

## MAGNETO TELEPHONES No. 1305 Type



No. 1305R

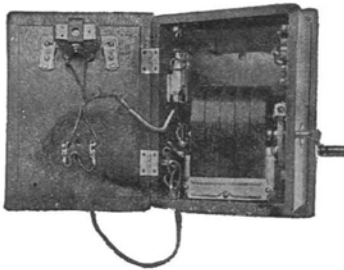

No. 1305R—Open

The No. 1305 type magneto telephones listed below are intended for use in places where a smaller telephone than the No. 1317 type is desired or made necessary on account of available space, the approximate dimensions of the backboard being 7½ inches wide by 10⅝ inches long.

This telephone has no space for batteries, nor is a writing shelf provided. The batteries in this case are supposed to be mounted in some out of the way place, either in a battery box or on a shelf.

The woodwork of the cabinet and the associated parts is of the same high standard as that of the No. 1317 telephone, the transmitting, receiving and ringing apparatus and efficiency of the two types being the same.

Our recommendation regarding batteries is the same as referred to under the No. 1317 (3 cell) type telephone, that is, when it is desired to secure the very highest transmission for long distance service or over lines where transmission conditions are very poor, three dry cells are recommended, but for all average local service and over all but the long toll lines, two Western Electric Blue Bell dry cells have been found to give perfectly satisfactory results.

The gongs of these telephones have a pleasing black finish which prevents tarnishing of the metal.

**The Following Prices Do Not Include Either Batteries or Protector,  
and These Should Be Ordered Separately as Desired**

### SERVICE DATA AND LIST PRICES RINGERS OPERATED BY ALTERNATING CURRENT (Code Ringing)

Code No.	Ringer Resistance, Ohms	Generator	Service	†List Price Each
*1305R	1600	48 type (5 bar A.C.)	Medium loaded lines	\$25.90
*1305AS	1600	50 type (3 bar A.C.)	Medium loaded lines	On request
*1305M	2500	48 type (5 bar A.C.)	Heavy loaded lines	25.70
*1305AT	2500	50 type (3 bar A.C.)	Heavy loaded lines	On request
*1305P	1000	22 type (3 bar A.C.)	Light loaded lines	18.20
1305N	50	22 type (3 bar A.C.)	Series lines	19.70
*1305AC	2500	48 type (5 bar A.C.)	For railway telephone service. Has an insulated generator crank. The induction coil and ringer coils are moistureproofed and the transmitter and switch-hook are black finish. Otherwise similar to the No. 1305M.	On request

### RINGERS OPERATED BY PULSATING CURRENT (Four-party Selective Signaling)

1305U	2500 ohms (biased)	22 type (2 bar A.C.)	Any one of four parties	\$20.80
-------	--------------------	----------------------	-------------------------	---------

\*Arranged for a 1 Mf. condenser to be wired in the receiver circuit, but not so equipped unless specified on order.

†These prices include a No. 143AW composition shell receiver. If the No. 144AW hard-rubber shell receiver is desired, 50 cents should be added to the list price of each telephone to be so equipped.

## MAGNETO TELEPHONES

### Desk and Arm Types

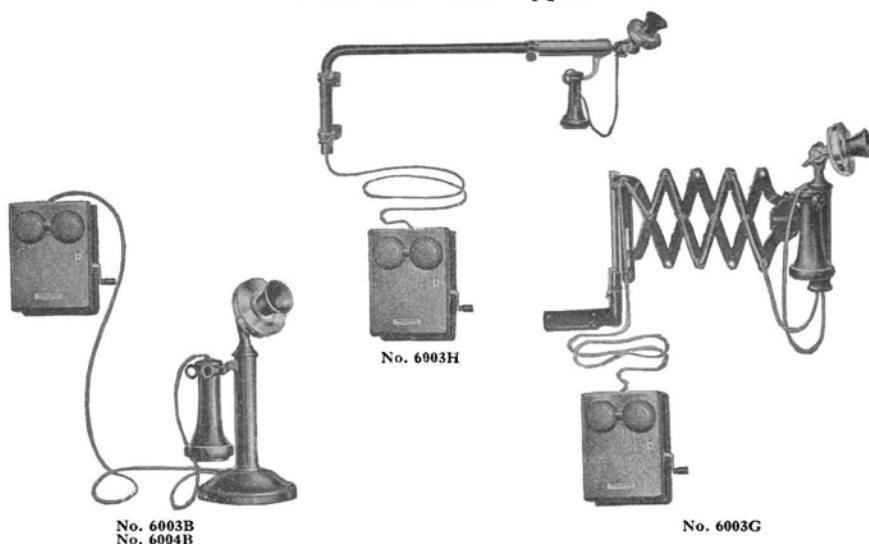

Desk telephones or those with extension arms are usually very popular, and, in the case of desk telephones, are used almost exclusively for business service, this probably being due to the convenience of this type of telephone over a wall instrument, and, being portable, can be placed on a desk, table or shelf within easy reach of the user.

The transmitting and ringing efficiency of these telephones is the same as of the corresponding wall telephones previously described.

#### DESK STANDS

The finish of the desk stands furnished with these telephones is our standard black, nickel finished stand being furnished only on a special order and at an advanced price. These desk stands are equipped with our well known standard long distance transmitter and concealed binding post receiver, and is standard Western Electric apparatus for this class of service.

#### TELEPHONE ARMS

The No. 1020AC adjustable arm is furnished for use on flat top desks or tables and has a radius adjustment of from approximately 35 to 48 inches.

The No. 1048AC arm is a collapsible, swinging arm mounted on top of a desk or table.

Length of arm closed, 9¾ inches.

Length of arm extended, 24½ inches.

As in the case of desk stands, these arms are equipped with our well-known standard long distance transmitter and concealed binding post receiver.

The finish of both these arms is our standard black.

NOTE: For brackets or arms for holding regular desk stands see page 279.

#### DESK SET BOXES

The woodwork of these boxes is of the same high quality and workmanship as that employed in the construction of our wall telephones. They contain a standard generator, ringer, induction coil and the necessary terminals for connecting the line and battery wires and the desk stand cord. In the case of the Nos. 6004B, C, D and E telephones, provision is also made for inserting a No. 21 type condenser which can be connected in series with the receiver. Condensers, however, are not furnished unless so specified.

## MAGNETO TELEPHONES

### Desk and Arm Type (Continued)

**The Following Prices Do Not Include Either Batteries or Protector, and These Should Be Ordered Separately as Desired**

#### SERVICE DATA AND LIST PRICES

##### RINGERS OPERATED BY ALTERNATING CURRENT

(Code Ringing)

Code No.	Desk Stand	Telephone Arm	Desk Set Box	Ringer Resistance, Ohms	Generator	Service	†List Price Each
6003B	1020AL	.....	315H	1000	22 type (3 bar A.C.)	Light loaded lines	\$23.00
6003G	.....	1048AC	315H	1000	22 type (3 bar A.C.)	Light loaded lines	27.30
6003H	.....	1020AC	315H	1000	22 type (3 bar A.C.)	Light loaded lines	32.30
‡6004B	1020AL	.....	300K	2500	48 type (5 bar A.C.)	Heavy loaded lines	28.90
‡6004C	1020AL	.....	300L	1600	48 type (5 bar A.C.)	Medium loaded lines	28.90
‡6004D	1020AL	.....	300AA	2500	50 type (3 bar A.C.)	Heavy loaded lines	On request
‡6004E	1020AL	.....	300AB	1600	50 type (3 bar A.C.)	Medium loaded lines	On request
6025A	1320CN	.....	315G	50	22 type (3 bar A.C.)	Series lines	23.60

##### RINGERS OPERATED BY PULSATING CURRENT

(Four-party Selective Signaling)

6003C	1020AL		315J	2500	22 type (2 bar A.C.)	Any one of four parties (biased)	\$24.00
-------	--------	--	------	------	----------------------	----------------------------------	---------

##### RINGERS OPERATED BY HARMONIC CURRENT

(Four or Eight-party Selective or Sixteen-party Semi-selective Signaling)

Code No.	Desk Stand	Desk Set Box	Frequency (Cycles)	Generator	Service	*List Price Each
6031A	1020AL	354A	33 $\frac{1}{2}$	22 type (3 bar *)	} Harmonic selective signaling lines only	\$26.70
6031B	1020AL	354E	50	22 type (3 bar *)		26.70
6031C	1020AL	354F	66 $\frac{2}{3}$	22 type (3 bar *)		26.70
6031D	1020AL	354G	16 $\frac{2}{3}$	22 type (3 bar *)		26.70

\*Arranged to give alternating current, but contact springs are arranged so that approximately one impulse of current out of four are sent over the line.

†These prices include a No. 143AW composition shell receiver. If the No. 144AW hard rubber shell receiver is desired 50 cents should be added to the list price of each telephone to be so equipped.

‡Arranged for a No. 21 type condenser to be wired in the receiver circuit, but not so equipped unless specified on order.

## Portable Telephones

Portable telephones are described under the heading "Railway Telephones"

## MINE TELEPHONES

### General

A reliable telephone system in a mine will enable the superintendent to communicate instantly with all the important parts of the plant. The saving in time and money which it effects by reliably transmitting routine orders or when there is a temporary suspension of power, a shutdown of some part of the plant, an accident or an emergency affecting both life and property, justifies many times over the investment required.

### Mine Laws

That the Legislatures of many of the States have made the installation of mine telephones and signals a requirement for mine operation is in itself sufficient endorsement of their usefulness. Those far-sighted operators who so quickly and wisely responded to these demands are already realizing the benefits of the increased operating efficiency that they effect in their mines along with the insurance against loss of life which was the primary object of the legislative acts.

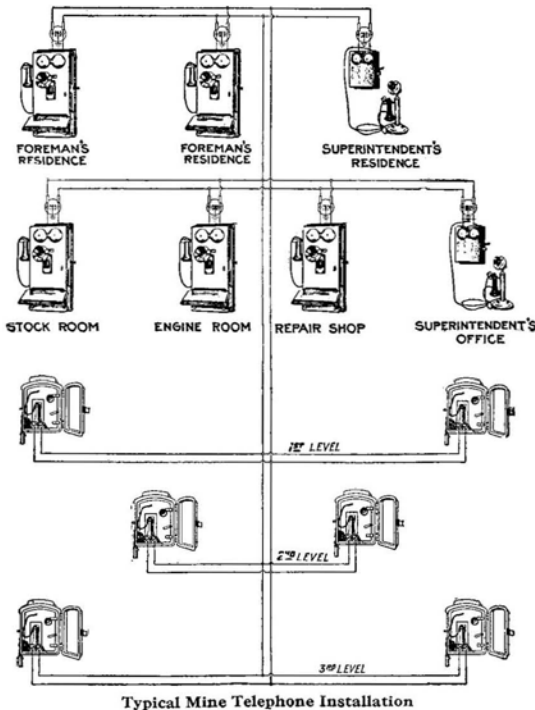

### Mine Telephone Systems

Mine telephone systems usually consist of several instruments connected to one pair of wires, forming a party line. Local battery magneto telephones are used and signaling is done by code rings.

The severe conditions encountered under ground, due to moisture, gases, acidulated water, etc., make it necessary to provide unusually well protected telephone instruments for this service. For use above ground, such as in the engine room, superintendent's office, etc., in conjunction with the mine system, standard wall or desk type telephone instruments can be used unless it is proposed to place them in exposed locations. In that event the metal case telephones should be used, the same as used below ground.

When the mine system requires more lines than one, they should be terminated in a switchboard located at some central point, such as the superintendent's office or engine house.

Switchboards suited to every requirement or condition are described elsewhere in this catalog under the heading of Switchboards.

Write for a copy of booklet, "Mine Telephone Systems and How to Install Them," sent you on request.



No. 1336 Type Mine Telephone  
Telephone Apparatus and Supplies

### No. 1336 Type

The No. 1336 type metal mine telephone is fireproofed, moistureproofed and rustproofed. Its iron case is curved at the top so that water and falling objects will easily slide off.

The apparatus inside the case is doubly protected from moisture, acid fumes and gases by two iron doors, and special treatment given each part to resist the action of such disturbing elements. When the inner door is closed only the metal transmitter mouthpiece, receiver, cord (impregnated with a moisture resisting compound) and the generator handle are exposed. When the outer door is closed even these parts are protected. In using the set it is evident that only the outer door need be opened.

## MINE TELEPHONES

### No. 1336 Type—Continued

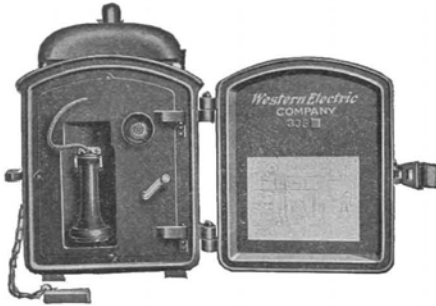

No. 1336 Mine Telephone (Outer Door Open)

It is often desired to provide loud-ringing extension bells, in conjunction with the telephone instruments at certain points when conditions are such that the bells furnished with the sets are not adequate. In this event, ringers or bells as a part of the instrument are unnecessary, and we are prepared to furnish telephones without bells when so specified in the order.

**Transmitter and Receiver** The transmitter and receiver are of standard quality and designed to give service under the most severe conditions known to exist.

**Generator** These telephones are equipped with a powerful 5-bar hand generator for signaling. This generator is of compact, durable construction and is very efficient. All exposed parts are heavily galvanized and the armature winding is impregnated with moistureproofing compound.

It is powerful enough to satisfactorily ring 40 telephones connected across the same line.

**Moisture-proofed Parts** The receiver cord, windings of the receiver, ringer coils and induction coil are impregnated with a compound to protect them from moisture and gaseous fumes and all permanent terminal connectors are also imbedded in the same compound. All interior wiring is done with heavy copper wire insulated with a high grade of rubber. These wires are formed and laced together into cables, which protect them from injury and also present a neat and compact arrangement.

**Condensers** Terminals are provided so that a condenser can be connected in the receiver circuit if desired. A condenser mounted and wired in each telephone makes it possible on a party line to ring the bells of all telephones on the line, even though several receivers may be off their hooks. Telephones will be furnished equipped with condensers if so specified on order.

**Accessibility** Accessibility of the working parts is one of the important features that have been looked after in the design of these telephones. Removable parts can be taken out and replaced when necessary without the use of a torch or soldering iron, as all connections are made with screws.

**Batteries** Two cells of standard dry battery are required for each telephone to furnish the talking current. Western Electric Blue Bell dry batteries are especially designed for telephone service and are recommended because they last longer and are more efficient in telephone work than any other battery available. In ordering batteries for telephones in use in underground or in damp locations, specify that they be furnished with "special impregnated cartons." These cartons resist the action of any moisture which may be present inside the case and prevent leakage and rapid deterioration.

**Entrance for Line Wires** The line wires can be brought in either at the top or the bottom of the case. When brought in at the top, the entrance pipe furnished with each set is used; this forms a drip loop in the wires and prevents water running into the set by following the wires.

When the line wires are brought into the set at the bottom, it is not necessary to use the entrance pipe. In this event, the opening at the top is closed by a plug provided for this purpose.

**Code Signals** By turning the generator crank you ring the bell of the telephone you wish to call, by means of a pre-determined signal or system of code rings (two short, three short, a long and a short or other combination of rings) repeated at intervals till the called telephone answers.

**Ringers or Bells** The instrument most generally used is equipped with a high-efficiency ringer or bell which operates on a minimum of current and which is so designed that it is nearly impossible to get out of adjustment. The construction and arrangement are such, however, that adjustments, when necessary, can be made easily and quickly with a screw-driver.

The gongs emit a very loud, distinct ring which can be heard a long distance under ground. They are given a special finish to prevent corrosion and are protected from injury by an iron hood mounted on the top of the case.



No. 1336 Mine Telephone  
(Outer and Inner Doors Open)  
Telephone Apparatus and Supplies

Code No.	Description	List Price Each
1336A	Metal case mine telephone, without ringer . . . . .	\$51.80
1336E	Metal case mine telephone, equipped with 2500 ohm ringer . . . . .	55.20
		209

**MINE TELEPHONES**

**Telephones for Above Ground Service**



**No. 1317 Telephone Wood Case—For Dry Locations**

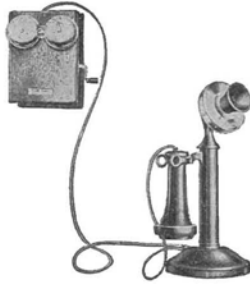

**No. 6004 Desk Telephone**

In the superintendent's office, engine house and other dry and protected parts of the plant which should have communication with each other and the mine, the No. 1317 standard wooden case telephone and No. 6004 desk stand telephone, listed in the preceding pages, can be used and are recommended. These telephones have been designed to meet the most exacting requirements of telephone service, and are standard with the largest telephone companies for heavy duty magneto service.

**Mine Telephone Extension Bells**



**No. 127 Extension Bell**

It is often desired to place a bell at some point distant from the telephone thus permitting the instrument to be located in a more or less sheltered position and still make it possible for the signals to be heard over quite an area. For this use two types of bells can be furnished. The Nos. 127, 392 and 342 types. These are listed under the heading "Extension Bells" elsewhere in this catalog.

Bells having ringer coils wound to either 1000 or 2500-ohms resistance can be furnished. In using these bells on lines in connection with telephones of other manufacture, the 1000 ohm type is recommended.

**No. 127** The No. 127 type is recommended for use above ground in dry, **Type** protected locations where a bell having the same sound volume as the bell furnished with the telephone instrument is satisfactory. Where a loud-ringing bell is required, the No. 392 or No. 342 types are recommended.



**No. 392 Extension Bell Loud-Ringing Type**

**Nos. 392** These extension bells are thoroughly protected against moisture, and **and 342** having impregnated coils and all exposed metal parts galvanized. They are so designed and constructed that it is almost impossible for them to get out of adjustment. However, they can be quickly and easily adjusted, if necessary.

The No. 392 is furnished equipped with 6 inch gongs. The No. 342 is also regularly equipped with 6 inch gongs and is mounted on a wooden backboard with canopy, as a protection against falling material; in case 8 inch gongs are required they can, however, be furnished.

**Mine Telephone Protectors**

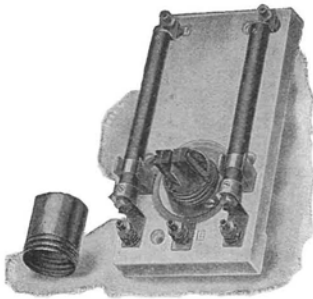

**No. 12A Protector Telephone Apparatus and Supplies**

It is customary to protect mine telephone instruments against lightning discharges and accidental crosses with lightning or power circuits. It is generally recognized by telephone authorities that a protector should be placed as near as possible to where the line wires enter the building, as by this method protection is afforded the inside wiring, the instrument and the building itself.

We manufacture several different types of protectors for use with telephone apparatus. The No. 60A protector is intended for protection against lightning only in locations where there is no chance of contact with electric light or power wires, and the No. 12A protector for protection both from lightning and foreign electric currents. This apparatus is listed under the heading "Protectors."

## MINE TELEPHONES

## Mine Signaling Sets



No. 343A Mine Signaling Set

The old method of electric signaling in mines was by means of single-stroke bells operated by battery current. Batteries at best are expensive for this kind of service, as they must be renewed frequently, even when not furnishing current due to deterioration.

The failure of one cell may cause the failure of the entire circuit at a critical moment and put the whole system out of service. This usually means a loss of valuable time and sometimes loss of property or life.

## No. 343A Signal Set

To provide a reliable system for such important work, we have designed and perfected the No. 343A Signal Set illustrated herewith. This set consists of a strong iron case containing a 5-bar No. 48D hand generator and two terminals. The line wires are brought into the set through a hole in the bottom.

The outer door is fastened with a strong hasp and staple and is locked with a padlock. On the front of this cover a small box having a glass window is provided in which is hung the padlock key. In case of emergency this window must be broken in order to open the set and turn the generator crank. This prevents tampering with the apparatus and insures its use only under circumstances that warrant.

**No. 48D Generator** The No. 48D generator furnished with this signaling set will ring 30 No. 342, 2500 ohms signal bells connected on a  $7\frac{1}{2}$  mile full metallic line of No. 12 B.W.G. iron wire or a  $28\frac{1}{2}$  mile line of No. 12 B.&S. hard drawn copper wire.

It is compact, durable, and has all exposed metal parts galvanized to make them rustproof. The armature winding is impregnated with a moistureproof compound and the magnet bars are made from special steel and will retain their strength indefinitely.

It is mounted inside the metal case and is made proof against dust and dirt by the iron plate which is held firmly against an iron shoulder with large screws. The generator handle only protrudes through the plate, and all other mechanism and wiring is entirely encased even when the outer door is open.

Prices quoted on request.

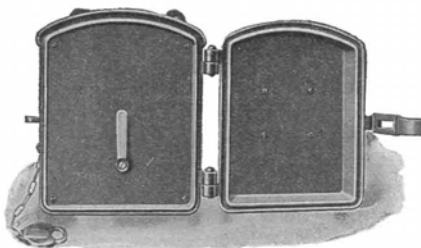

No. 343A Mine Signaling Set (Outer Door Open)

211

## Signal Bells

For receiving the signals either the No. 392 or No. 342 type loud-ringing bells can be used. These bells are alike in design and construction only, the No. 342 type is mounted on a wooden backboard with a canopy for extra protection from falling rocks or other objects.

Telephone Apparatus and Supplies

## MINE TELEPHONES

### Telephones for Use on Signal Wires of Rope Haulage Systems

#### Rope Haulage

In many mines, "rope haulage" is used as motive power for moving coal cars, this system being equivalent to a cable road, the cars being drawn by a moving cable.

In the operation of such a system it is necessary that the operator on the cars or "trip rider" be able to quickly signal the engineer to stop or start the cars. This is usually accomplished by stringing two bare iron or copper wires, suitably insulated, alongside the track and connecting the ends terminating in the engine room with a battery and relay. When the "trip rider" desires to signal the engine room he short circuits the two wires by means of a suitable piece of metal, which energizes the relay and causes a local circuit bell to ring. Code signals are used to indicate what is wanted.

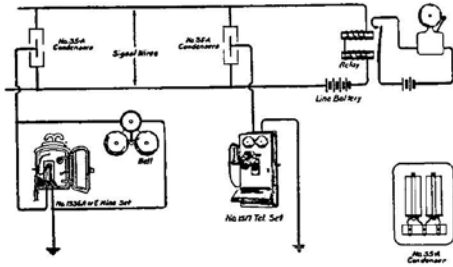

Diagram of Telephone System, Using  
Rope Haulage Signal Wires

#### Telephone Applications

There is considerable demand for telephones which can be connected directly to the present rope haulage signal wires, and the most satisfactory method of doing this is to use the two wires as one side of the telephone circuit, and the ground as the other side. See accompanying diagram.

In order that the telephones do not interfere with the rope haulage signaling it is necessary to connect the telephone instrument through a condenser to the signal wires.

To insure satisfactory operation of the telephone system, good ground connections must be secured and the signal wires must be well insulated and free from leaks and grounds. It is, of course, evident that this system cannot be installed where a grounded generator is used to furnish the signaling current.

**Equipment** No. 1336A or E mine telephone, previously described or the No. 1317 or 6004 telephones can be used, depending on the location and conditions.

With each telephone a No. 35A condenser is required. This consists of two 2M.F. condensers, properly wired and mounted in an iron box which can be installed in any convenient or desirable location. In case the insulation of the signal wires is poor it may be necessary to use two of the No. 35A condensers for each telephone. This, of course, will depend upon conditions and can be decided upon by trial.

#### Number of Telephones on Line

The number of telephones that will operate satisfactorily in such a system is also a matter of trial in each case. Generally speaking, however, it will not be advisable to use more than two or three, and it must be understood that such a system is only a "makeshift" and the service not to be compared to that secured by the use of a metallic circuit installed and maintained exclusively for telephone service. However, in cases where temporary service is required, or where financial conditions do not warrant the construction of other circuits this arrangement can be used to advantage.

**Telephone Apparatus and Supplies**

## MINE TELEPHONES

### Mine Rescue Telephones

In cases of explosions, cave-ins, etc., in mines or underground work, it is found necessary, and urgently recommended by the U. S. Bureau of Mines, to establish a means of communication between the rescue party and the surface or base of supplies.

The Western Electric Company has recently produced a light, serviceable and extremely simple telephone

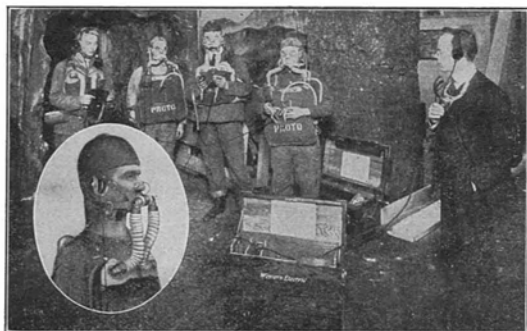

Mine Rescue Crew Using Rescue Telephone Apparatus

equipment for mine rescue work, to be used either alone or in conjunction with any of the now well-known types of oxygen-breathing apparatus on the market.

This equipment consists substantially of a special throat transmitter and head receiver held in place by a leather harness to be worn by one or more members of the advance or rescue party and a standard head receiver and chest type transmitter equipment for the use of the man at the outside or at the rear who is directing the rescue work.

**Wiring** The method of keeping the advance party connected up with the rear is accomplished through a small wire cable consisting of two copper conductors covered with an elastic enamel and two servings of cotton, covered over with a stout linen braid impregnated with a moisture-resisting compound.

**Wire Reels** This wire is furnished in 500 foot coils and is carried on a reel in a leather case fastened to the belt of the chief of the rescue party, and pays out as he advances. Each end of this coil is equipped with special connectors, one end for connecting with a jack attached to the head telephone equipment worn by the rescuer through a cord and plug, and the other end for connecting with the cord running to the battery and apparatus box at the rear.

As the reels of wire used are very light, several of them can be carried along by the rescue party, and as soon as one is run out another can be connected in by means of the connectors and the party proceed another 500 feet, and so on.

**Throat Transmitter** As a man equipped with any of the standard oxygen breathing appliances which covers his mouth cannot use the ordinary type of telephone transmitter, a special transmitter, known as the throat transmitter, has been developed which is the only type of instrument that will satisfactorily meet the special requirements of rescue service. This transmitter is very light and compact and is provided with a soft rubber cup designed to be held firmly against the throat. This transmitter has been found by actual test to be entirely satisfactory and to transmit speech clearly and distinctly.



Receiver, Throat Transmitter and Leather Head Harness

**Weight** The total weight of the equipment carried by the rescuer, including the head telephone apparatus, belt, leather reel box and one 500 foot reel of wire, is only 9 pounds.

## MINE TELEPHONES

## Mine Rescue Telephones

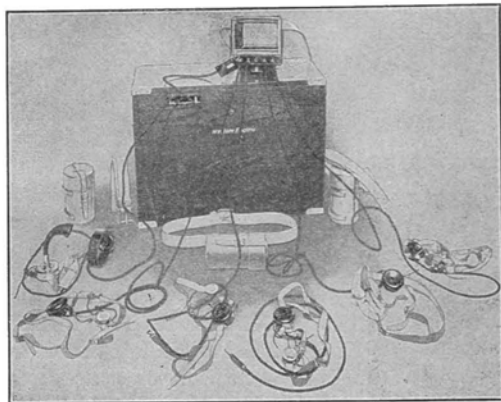

**Battery and Apparatus Box, Showing Apparatus**

The operator's telephone set, which consists of a chest type transmitter and head-band receiver, is connected with the other apparatus mounted in the battery box through four screw-binding post terminals.

The battery key operates in two directions and has three positions—neutral, right and left. When the handle is pushed one way, it connects the battery gauge across the battery terminals. This testing apparatus is provided so that when the equipment is to be used, it can be immediately determined whether the batteries are in good condition or not, as it would be a serious matter to have the rescue party proceed into the mine and later find that the batteries were too weak to give good service. When the handle is pushed in the opposite direction, it locks in that position until released and disconnects the batteries from the circuit, which of course saves current while the apparatus is temporarily out of service. When the key is in its neutral or center position, the batteries are connected with the circuit.

**Cable Reel Box** In many cases it will be found desirable to use cable for carrying the circuit down a shaft or into a slope mine up to the edge of the danger zone. For this purpose a large box equipped with a cable reel is furnished. It consists of a heavily reinforced, metal-bound, mortise-cornered box made of ash, containing a reel on which is wound 1300 feet of special No. 16 B.&S. gauge stranded, twisted, paired, rubber-covered and braided cable.

As this equipment will be more often used at the top of a shaft, a heavy ratchet and pawl are provided to prevent the reel from turning after the proper amount of cable has been paid out. On the end of the cable, which is either left down the shaft or drawn into the slope, is a connector which joins with the coil of wire carried by the rescue party. The electrical contact with the inside end of the cable is made through a pair of substantial collector rings mounted on the reel against which press commutator brushes leading to a connector in the upper right hand corner of the box. Connection between the reel box and the smaller battery and apparatus box is made by attaching the cord furnished with the latter-mentioned piece of apparatus to the connector referred to.

For further information and prices write our nearest house.

Telephone Apparatus and Supplies



**Cable Reel Box**

214

**Battery and Apparatus Box** The battery and apparatus box is always a necessary part of the equipment, and must be located at the point where the person who is directing the rescue work in the rear by means of a telephone is stationed. It contains 12 dry batteries mounted in the bottom of the case, battery key, an induction coil, a battery gauge and a number of screw terminals or binding posts mounted in a separate removable compartment which can be easily lifted out.

The circuit extends from the battery to two flat springs, which press against metal strips fastened on this removable compartment so that when it is put in place it is automatically connected with the batteries.

## RAILWAY TELEPHONES

The following local battery telephones are intended for use primarily on lines in connection with steam and electric railways.

## For Railway Train Dispatching Lines

The following telephones are for use on railway train dispatching circuits, at sidings and similar places for the use of trainmen. A high efficiency transmission circuit is employed, which is specially designed and adapted for this service.



No. 1317W

In the case of the Nos. 1317W, AW, AD, AE, No. 1293 type and No. 1336F telephones a push button is furnished which, when pressed, closes the local transmission circuit, making it necessary for the user to keep the push button depressed while talking. The No. 1317BD and BC and No. 1336H have a slightly different transmission circuit which does not necessitate the use of a push button.

## No. 1317 Type

These telephones are equipped with a No. 48A (5 bar A.C.) generator, No. 21AA (1 Mf.) condenser, 1003A push button (except Nos. 1317BC and BD), induction coil, No. 51A retardation coil (except Nos. 1317BC and BD), No. 282W transmitter and with receivers and ringers as listed below.

**Two Blue Bell Batteries and One No. 60A Protector Are Furnished with Each of the Following Listed Telephones and Are Included in the Price**

**Note:** If batteries are not desired, deduct 60 cents from the list price.

If protector is not desired, deduct 50 cents from the list price.

## SERVICE DATA AND LIST PRICES

Code No.	Ringer		Receiver	Description	List Price Each
	Code No.	Resistance Ohms			
1317W	38BG	2500	No. 163W	Siding telephone for use on railway train dispatching circuits.	\$32.20
1317AW	38BG	2500	No. 156W (head band)	Similar to 1317W except furnished with head receiver equipment.	33.30
1317AD	.....	.....	No. 163W	Similar to 1317W except ringer is omitted.	29.10
1317AE	.....	.....	No. 156W (head band)	Similar to 1317AW except ringer is omitted	30.10
1317BC	38BG	2500	No. 144AW	Similar to 1317W except a different transmission circuit is employed and the push button is omitted.	31.00
1317BD	38BG	2500	No. 148W	Similar to 1317W except a different transmission circuit is employed, the push button is omitted and head receiver is furnished.	32.70

**RAILWAY TELEPHONES**

**No. 1293 Type**



No. 1293AD

These are small, compact wall telephones not equipped with generators. No space is provided for batteries, it being assumed that they will be mounted separately in a battery box or on a shelf in some out of the way location. These telephones are equipped with a push button which must be pressed by the user while talking.

The telephones listed below are the same except that the No. 1293AE and AL are equipped with a head band receiver instead of a standard hand receiver and the No. 1293AK and AL are not equipped with ringers. These telephones are equipped with a No. 21AA (1 m.f.) condenser, No. 29 induction coil, No. 51A retardation coil, No. 1003A push button, No. 284W transmitter and with receivers and ringers as indicated.

Code No.	Ringers	Receivers	*List Price
			Each
1293AD	No. 4BG (2500 ohms)	No. 163W	\$27.00
1293AE	No. 4BG (2500 ohms)	No. 156W (head type)	29.30
1293AK	None	No. 163W	24.00
1293AL	None	No. 156W (head type)	25.90

\*The above prices do not include either batteries or protector; these should be ordered separately as desired.

**No. 1336 Type**

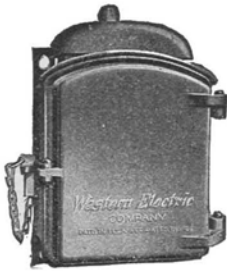

No. 1336H

These telephones have an iron case and are adapted for out of door use on railway train dispatching circuits.

All parts, such as the ringer coils, induction coil, generator, armatures, receiver, receiver cord, transmitter, etc., are treated with a moisture-proofing compound and all other metal parts are rustproof. Space is provided in the case for two standard 2½ ins. x 6 ins. dry cells, but these are not included in the price and should be ordered separately as desired. A standard switch lock can be used for fastening the door if desired. This is a thoroughly weatherproof and reliable instrument for this class of service.



No. 1336H

The two telephones listed differ in that the No. 1336F employs a push button which must be pressed by the user when talking, while the No. 1336H employs a slightly different transmission circuit, which makes the use of a push button unnecessary.

Code No.	Generator	Ringer	Push Button	Transmitter	Receiver	Retardation Coil	List Price Each
1336F	48C (5 bar A.C.)	45BG (2500 ohms)	1002A (special)	292W (Special)	166W	51B	\$65.30
1336H	48C (5 bar A.C.)	45BG (2500 ohms)	None	292W (Special)	144AW	None	58.50

Telephone Apparatus and Supplies

## RAILWAY TELEPHONES

### Street Railway Telephones

#### No. 1278 Type

This is a weatherproof iron box telephone designed to be fastened to poles along a street railway line where it will be most convenient for the use of the car men. The following apparatus is mounted on a removable base:

No. 48 type (5 bar A.C.) generator, ringer, induction coil, two fuses, two open space carbon cutouts, and automatic door switch which is operated by the opening and closing of the door, and a No. 25 type repeating coil. The repeating coil insulates all metallic connection between the line and telephone instruments, thus eliminating as far as possible any danger from the line, should it become crossed with foreign current-carrying wires. The ringing current and talking currents are both transformed through this coil either out over the line or into the instrument, as the case may be. Closing the door operates the door switch and disconnects the repeating coil from the line, and also breaks the local transmitter battery circuit. This prevents current from passing through the repeating coil except when the telephone is in use, and also prevents any unnecessary drain on the battery.

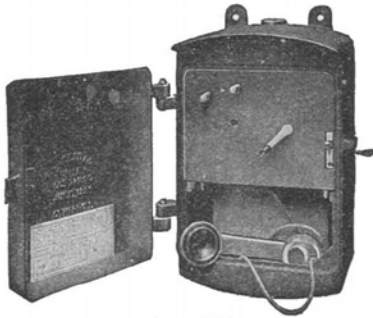

No. 1278G

The lower part of the case is arranged to hold two dry cells and the No. 1001 type hand set and cord when not in use. The cord used is weatherproof and of sufficient length to enable the user to stand in a comfortable position while talking.

The No. 1278G telephone is provided with a lock so constructed that after the key has been inserted and the door opened the key is held tightly in place and cannot be removed until the door has been properly closed again. This serves to insure the closing of the door before the user returns to his car.

Code No.	Generator	Ringer	Hand Set	Door Lock	Fuses	List Price *Each
1278G	48C (5 bar A.C.)	51A (1000 ohms)	1001F	5B	Two 500 volt, 1 ampere	\$85.50
1278H	Same as No. 1278G except that a hasp and staple are substituted for the 5B lock, thus permitting standard switch locks to be used.					82.20

\*The above prices do not include batteries; these should be ordered separately as desired.

### Railway Composite Telephone Apparatus

These telephones are intended for furnishing telephone service over grounded telegraph lines simultaneous with the telegraph messages. They are adapted to use on single Morse lines, but are not suitable or intended for use on duplex or quadruplex lines or when machine sending is employed. To adapt the telegraph line to telephone service requires no change in the telegraph apparatus or its operation. All that is necessary is to bridge the telegraph apparatus at each station with a condenser and resistance and connect the telephone instruments between the line and the ground. Telephone signaling is accomplished by pressing a push button which places high frequency currents on the line by means of an interrupter and induction coil. This current causes howlers located at the different telephone stations to produce a loud, sharp sound which can be readily heard for a considerable distance. Code signals are used for calling any particular station. A local battery talking circuit is employed, batteries being located at each telephone.

## RAILWAY TELEPHONES

## Railway Composite Telephone Apparatus (Continued)

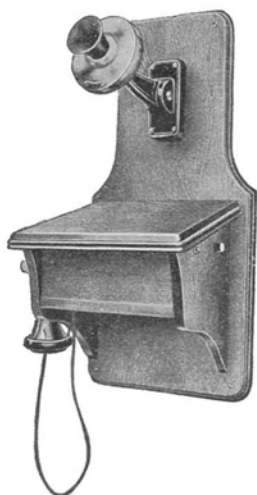

No. 1312A

The length of the telegraph line and the number of telegraph stations with which this composite telephone apparatus can be successfully used depends largely upon the character of the telegraph line. As a general indication of the possibilities of the system, however, successful operation should be practicable over ordinary telegraph lines up to 100 miles long and with as many as five intermediate telegraph stations.

**The Necessary Apparatus for Each Terminal Telegraph station consists of:**

1 No. 1212A wall telephone or 1 No. 6023A desk telephone.

10 Western Electric Blue Bell dry cells.

1 No. 27B condenser.

1 No. 48A retardation coil.

1 No. 58B protector.

**The Apparatus necessary for each Intermediate Telegraph Station Consists of:**

1 No. 1312A wall telephone or 1 No. 6023A desk telephone.

10 Western Electric Blue Bell dry cells.

1 No. 58B protector.

**The Apparatus for a Portable Telephone Outfit Consists of:**

1 No. 1314A portable telephone.

4 Western Electric Blue Bell dry cells.

1 No. 4 line pole.

**The Additional Apparatus Required for Each Telegraph Station Between the Terminal Telephones Consists of:**

1 No. 27B condenser.

1 No. 31A resistance.

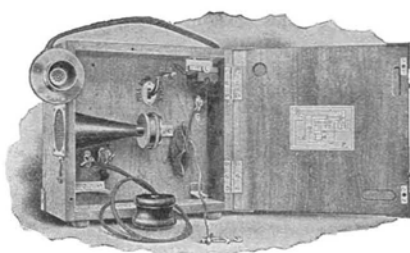

No. 1314A

Code No.	Transmitter	Receiver	Howler	*List Price Each
<b>Wall Telephones</b>				
1312A	No. 286W	No. 144AW	No. 1C	\$42.80
<b>Portable Telephones</b>				
1314A	No. 228W	No. 133W	No. 1B	\$58.50
<b>Desk Telephones</b>				
No. Code	Desk Stand	Desk Set Box	Howler	List Price Each
6023A	No. 1020U	No. 311A	No. 1C	\$41.10

\*The above price includes the telephone only. Batteries and other accessory apparatus must be ordered separately.

Telephone Apparatus and Supplies

## RAILWAY TELEPHONES

### Portable Telephones

The use of portable telephones, by steam and electric railways has been of great assistance in increasing their operating speed and efficiency. Portable telephones also find many other uses too numerous to mention here.

There is a Western Electric portable telephone to suit every kind of service and to operate satisfactorily on any line, and ranging from a simple receiving or listening telephone to one capable of ringing all the bells on a heavily loaded line. These telephones are equipped with standard Western Electric transmitters, receivers, generators, ringers, induction coils and other apparatus and are designed to give perfectly satisfactory service. These telephones are all mounted in a strong case of either wood or leather, well reinforced at the corners and intended for rough service and to withstand ordinary weather conditions.

### Nos. 1330 and 1331 Types

#### PORTABLE MAGNETO TELEPHONES IN WOODEN CASES

These portable telephones are intended for connecting to regular bridging magneto lines, and are equipped with a standard local battery circuit.

They are contained in substantial wooden cases made of hard maple, having the corners reinforced with aluminum brackets. Cases are regularly furnished with a substantial leather suitcase handle. If so specified on the order, however, a broad leather shoulder strap can be furnished in place of the handle or in addition to it.



No. 1330E



No. 1331E

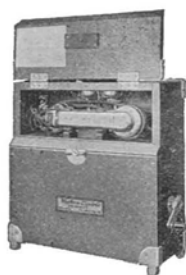

No. 1330E

#### Apparatus

These telephones are equipped with a No. 1001 type hand set which consists of a transmitter and receiver on one handle and which is designed to stand much hard use and abuse without impairing its transmission or receiving efficiency. These hand sets have been in service for many years and have given universal satisfaction. They are equipped with a push button switch

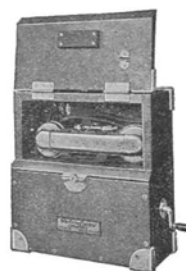

No. 1331E

located in the handle in such a position that it is easily operated by the thumb or finger while holding the hand set. They are connected with the case or box by means of a six-foot waterproof cord, thus enabling the user to stand or sit in any position while the box is either resting on the ground, hung on a pole or other location. This feature is quite important as were the transmitter mounted permanently in the cabinet it would be very inconvenient to talk under many circumstances.

## RAILWAY TELEPHONES

## Nos. 1330 and 1331 Types—Continued

The Nos. 1330F and 1331F are equipped with a six foot cord and No. 146 plug for connecting with the line through a No. 186 pole jack, while the Nos. 1330E and 1331E are intended for use in connection with a No. 3 or No. 5 line pole which must be ordered separately.

The Nos. 1330E and 1331E telephones are furnished equipped with a 1 Mf. condenser wired in the receiver circuit as standard. Condensers are not furnished with the Nos. 1330F or 1331F unless so specified on order.

Code No.	Method of Connecting to Line	Ringers	Generator	Service	*Batteries Used	Approx. Wt. Complete	List Price Each
1330E	Line Pole						
1330F	No. 146 plug and cord	32BG (2500 ohms).....	48A (5 bar)	Heavy loaded lines	2 Blue Bell	28 lbs.	\$55.70 64.20
1331E	Line pole						
1331F	No. 146 plug and cord	3R buzzer (2500 ohms).....	22A (3 bar)	Light loaded lines	1 No. 792 Eveready	17 lbs.	50.70 59.70

\*Batteries are not furnished unless specified in order.

## Nos. 1332 and 1375 Types

## PORTABLE TELEPHONES IN LEATHER CASES

These portable telephones are encased in heavy bag leather cases securely sewed and designed to stand rough usage without showing undue wear, and equipped with a suitable shoulder strap of best quality.

## No. 1332 Type

These portable telephones have no generator and are intended for use on railway train dispatching lines where the dispatcher is always "listening in" on the line.

The No. 1332A and E differ only in that the No. 1332E is equipped with a 2500 ohm buzzer for receiving signals, while the No. 1332A is not equipped with any signal receiving apparatus. The usual method of connecting these telephones with the line is by means of a No. 3 or No. 5 line pole.

The apparatus is compactly mounted on a wood and metal frame which can be easily removed as a unit from the case for inspection or adjustment when necessary.

The line binding posts are conveniently placed on a terminal plate directly under the cover. These telephones are furnished equipped with a standard No. 1001C hand set, induction coil and condenser, and are arranged to hold a No. 792 Eveready tungsten battery, but batteries are not furnished unless so specified in order.



No. 1332A

Code No.	Buzzer	Approximate Weight	List Price Each
1332A	None	6 lbs.	\$38.50
1332E	2500 ohms	6 lbs.	41.20

Telephone Apparatus and Supplies

## RAILWAY TELEPHONES

## Nos. 1332 and 1375 Types—Continued

## No. 1375B Type

This is a complete portable magneto telephone for connecting to metallic or grounded lines and capable of ringing the bells on a heavily loaded circuit.

The apparatus is compactly mounted on an aluminum frame which can be easily removed as a unit from the case for inspection or adjustment when necessary. The line and ground terminals are conveniently mounted on a terminal plate directly under the cover. The equipment consists of a standard No. 1001 type hand set, induction coil, generator, 2150 ohm buzzer for receiving signals and a No. 703 Eveready dry battery.

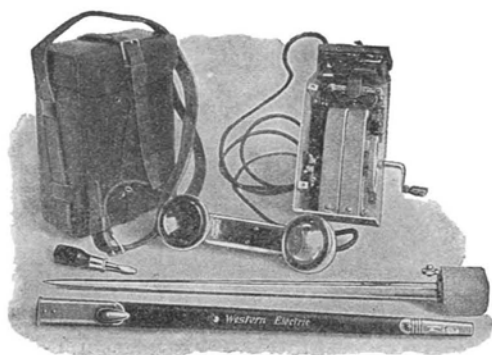

No. 1375B

This portable telephone is especially adapted for line patrolmen and others who are frequently out of reach of a permanent telephone station and who must carry a light and compact telephone for communicating to headquarters quickly in an emergency.

The following equipment is intended for use with these sets, but will not be furnished unless specified in the order:

One Bayonet Type Ground Rod per Spec. D-313 provided with a brass scabbard and a 10 foot connecting wire for attaching to set.

One Line Connection Wire per Spec. D-311 consisting of a 40 foot length of No. 14 B.&S. flexible rubber covered and braided copper wire, equipped with tips at each end and having a 4 inch bared space at the middle.

The usual method of connecting this telephone to the line is either by means of a line pole or by means of the line connecting wire. This wire is thrown over the line and held in such a position that the bared wire is in contact with the line wire, and either one or both ends of the wire being connected to one terminal of the telephone, the other terminal being connected either to the ground by means of a bayonet ground rod or other ground connection, or to the other line wire by means of another line connecting wire in the case of a metallic circuit.

Code No.	Hand Set	Generator	Buzzer	Battery	Weight	List Price Each
1375B	1001H	No. 29E	2150 ohms	No. 703 Eveready	10½ lbs.	\$67.50

## LINE CONNECTING WIRE

Spec. D-311	(As described above)	\$1.00
-------------	----------------------	--------

## BAYONET GROUND ROD

Spec. D-313	(As described above)	\$6.00
-------------	----------------------	--------

## CENTRAL BATTERY TELEPHONES

The Western Electric Company manufactures two general types of central battery telephones:

(a) Induction Coil Type

(b) Series Type

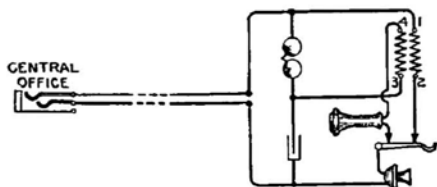

FIG. 1  
Circuit of Induction Coil Telephone

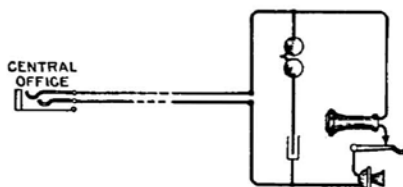

FIG. 2  
Circuit of Series Telephone

### Induction Coil Telephones

The **INDUCTION COIL TYPE**, as the name implies, is equipped with an induction coil and wired, as shown in figure No. 1. The transmitter is of our long-distance type, and the receiver is of the bipolar magnet type. The induction coil instruments and circuit are extremely efficient in transmission, and are recommended for all subscriber lines over two or three miles in length, or where highly efficient transmission is required for toll service, etc.

### Series Telephones

The **SERIES TYPE** is not equipped with an induction coil, but the receiver and transmitter are connected in series, from which arrangement the type derives its name. This is illustrated in figure No. 2. The receivers used with these telephones do not have a permanent magnet, and are therefore known as "direct current" or "electro-magnetic" receivers.

Due to the omission of the induction coil in this circuit, the talking efficiency of the transmitter is slightly lower than in the induction coil telephone, especially on lines exceeding two or three miles in length. The receiving efficiency on short lines, however, is equal to or better than the induction coil telephone on lines of similar length.

### Conclusions

Summarizing the above: Series telephones are very satisfactory on short subscriber lines (one or two miles), but on long lines (over two or three miles) the transmission efficiency is somewhat less than our induction coil apparatus.

## WALL AND DESK TELEPHONES

The various wall and desk type telephones listed on the following pages will meet every requirement of central battery service on single and party lines. There is a Western Electric telephone to satisfy every requirement.

### No. 1333 Metal Wall Telephones

These telephones are the most perfect central battery instruments yet produced, our experience of over thirty-five years in the design and manufacture of telephone apparatus having been put into them. They embody the most modern practices of the telephone art.

The cover is of heavy sheet metal, copper plated and covered with two coats of black enamel, the result being a tough, elastic, non-chipping finish which is serviceable, uniform and free from blemishes and rough spots.

Every part of the interior is readily accessible when the door is opened for test or inspection.

## CENTRAL BATTERY TELEPHONES

### No. 1333 Metal Wall Telephones (Continued)



No. 1333 Telephone

Spacing of apparatus is ample without sacrificing the compactness of the telephone.

All binding posts are of the screw type. Permanent connections are soldered.

View of ringer is unobstructed so that action can be watched while adjusting.

All wiring is in cable form, rendering wires less liable to damage, and producing a neater looking and more accessible interior.

Wires are of different colored insulation, making it easy to trace the circuit.

The induction coil and condenser are mounted so that they may be removed as a unit.

A picture wiring diagram with clear, concise instructions is furnished with every telephone.

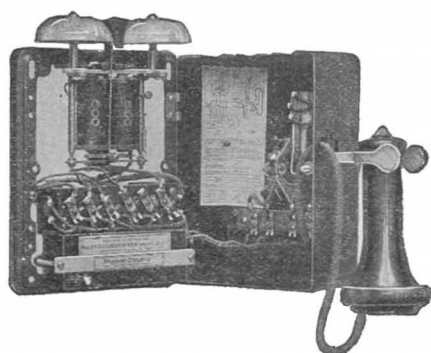

No. 1333 Telephone—Open

### No. 6032 Metal Desk Telephone

These desk telephones consist of a metal desk set box, desk stand and cords.

The stands are strongly built, though light in weight, with a durable black, non-chipping finish. Contact springs, binding posts, lug holders and switchhook are assembled on one terminal plate and can be removed as unit for inspection by loosening one screw. The base is covered with felt and can be replaced at small cost when worn out. All parts are of ample size, and their proportions are such that the stand is not easily upset.

The desk set box is constructed of the same heavy sheet metal as the wall telephones, and is copper plated and given two coats of black enamel.

## Apparatus

### RECEIVER

The receiver supplied is of the standard Western Electric type.

A special grade of steel for the permanent magnets enables them to retain their strength indefinitely. The spool cores are made of special annealed Norway iron. The permanent magnets and spool cores are welded together electrically, forming a perfect magnetic circuit and producing maximum efficiency. Ends of electro-magnet cores are absolutely smooth, and lacquered to protect them from rust. The receiver cup back of the diaphragm is made air-tight and dust cannot accumulate between the moving parts.



No. 6032 Telephone

## CENTRAL BATTERY TELEPHONES

### Apparatus (Continued)

#### TRANSMITTER

The transmitters have extremely high efficiency for both long toll or local service. All exposed metal parts are insulated, and the carbon used comes from a selected mineral vein, specially treated, resulting in a transmitter which does not pack or burn, is uniform in operation and does not change in service, consuming a minimum of current for the high grade of transmission produced. The transmission is the best obtainable, clear and distinct.

#### SWITCHHOOK

All current-carrying parts are well insulated from the frame. The springs are of heavy German silver backed by brass stop springs, insuring positive operation and maximum contact pressure. The contact springs are mounted vertically to prevent accumulation of dust on the contacts. Hard rubber rollers at end of switchhook rest against master contact spring, eliminating friction and sticking when hook is operated.

#### INDUCTION COIL

This is a vital part of the induction coil telephone circuit, carefully designed to meet the requirements of local and long-distance work. The terminals are firmly secured to the spool heads.

#### CONDENSER

The condensers are thoroughly protected against moisture by the use of a special compound. Electrostatic capacity remains practically constant, equal to or greater than that specified. The high insulation resistance—500 megohms per microfarad—is maintained indefinitely. The paper and tinfoil are specially made in accordance with comprehensive specifications, and subjected to rigid physical and chemical tests. Terminals are brought out and formed over to be accessible from either the end or the top.

#### RINGERS

The ringers are extremely sensitive, sturdy in mechanical structure and permanent in adjustment. Black enamel wire is used for the ringer coils, producing more effective ampere turns than a silk insulated wire, as well as a louder ring. Slotted holes in gongs prevent them from turning on the gong posts and becoming loose. Gong posts are mounted direct on ringer frame—and the gongs may be easily and accurately adjusted. Harmonic ringers are closely and accurately tuned. They will operate through a wide range of voltage and over long lines.

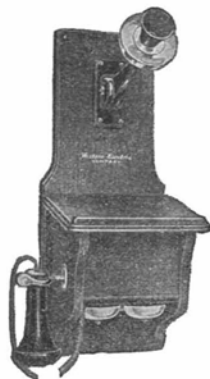

No. 1294 Telephone

### Nos. 1294 and 1296 Wall Telephones

These are wooden wall telephones—regularly finished in oak as standard.

Used in 4 party selective signaling service employing pulsating or superimposed current, and are equipped with a relay in addition to the other apparatus.

The No. 1296E telephone has an inverted circuit and should be used in place of the No. 1296F in case ground potential (earth currents) interferes with the operation of the ringers.

### No 6041A Desk Telephone

This desk telephone consists of an oak desk set box and desk stand with cords. It is used in 4 party selective signaling service when pulsating current is employed. Relay is mounted in desk set box.



No. 1296 Telephone

Telephone Apparatus and Supplies



No. 6041A Desk Telephone

## CENTRAL BATTERY TELEPHONES Induction Coil Telephones

Equipped with transmitter, receiver, induction coil, condenser and ringer.

### Ringers Operated by Alternating Current Individual, 2 Party Selective or 4 Party Semi-selective Signaling WALL TELEPHONES

Code No.				
1333B	Ringer 1000 ohms (biased)			List Price Each \$15.80
	<b>DESK TELEPHONES</b>			
Code No.	Ringer	Desk Stand	Desk Set Box	List Price Each
6032W	1000 ohms (biased)	1020AL	334A	\$19.80

### Ringers Operated by Harmonic Current 4 or 8 Party Selective or 16 Party Semi-selective Signaling WALL TELEPHONES

Code No.				
1333AF	Ringer 33½ cycles			List Price Each \$17.40
1333AG	50 cycles			17.40
1333AH	66⅔ cycles			17.40
1333AJ	16⅔ cycles			17.40
	<b>DESK TELEPHONES</b>			
Code No.	Ringer	Desk Stands	Desk Set Box	List Price Each
6032K	33½ cycles	1020AL	334E	\$22.40
6032L	50 cycles	1020AL	334F	22.40
6032M	66⅔ cycles	1020AL	334G	22.40
6032N	16⅔ cycles	1020AL	334H	22.40

### Ringers Operated by Pulsating or Superimposed Current 4 Party Selective Signaling WALL TELEPHONES

Code No.				
*1294AC	Ringers 1000-3000 ohms (a) (biased)			List Price Each \$23.20
*1296F	1000-3000 ohms (a) (biased)			22.20
*†1296E	1000-3000 ohms (a) (biased)			22.40
	<b>DESK TELEPHONE</b>			
Code No.	Ringer	Desk Stand	Desk Set Box	List Price Each
6041A	1000-3000 ohms (a) (biased)	1020AL	*297G	\$26.10

\*Equipped with a relay in addition to other apparatus.

†Has an inverted circuit for use in locations where ground potential interferes with the ringers of the No. 1296F.

(a) Ringer has an inductive winding of approximately 1000 ohms, and a non-inductive winding of approximately 3000 ohms wound over the inductive winding of one spool. These two windings are connected in series and the junction brought out to an extra terminal for use in connecting an extension instrument or bell.

‡These prices include furnishing a No. 143AW composition shell receiver. If the No. 144AW hard rubber shell receiver is required, add \$0.50 to the list price of each telephone to be so equipped.

### Series Telephones

Equipped with transmitter, receiver, condenser and ringer.

### Ringers Operated by Alternating Current Individual, 2 Party Selective, or 4 Party Semi-selective Signaling WALL TELEPHONES

Code No.				
1333K	Ringer 1000 ohms (biased)	Transmitter Mounting Non-flush—Adjustable		List Price Each \$14.70
1333L	1000 ohms (biased)	Flush—Non-adjustable		13.80
	<b>DESK TELEPHONE</b>			
Code No.	Ringers	Desk Stand	Desk Set Box	List Price Each
6032U	1000 ohms (biased)	1020AH	334N	\$17.60

### No. 1320 Police Telephone



No. 1320—Closed

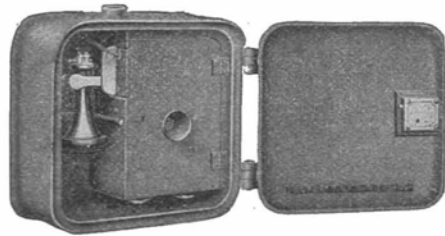

No. 1320—Outer Door Open

A weatherproof central battery telephone, inclosed in a cast iron box and specially adapted for police patrol service. All apparatus is mounted on a frame which can be removed as a unit from case.

Equipped with unbiased 1000 ohm ringers and intended for straight alternating ringing only.

Code No.			
1320A	Lettering on door, as specified . . . . .		List Price Each \$64.20

## CENTRAL BATTERY TELEPHONES

### Telephones for Use with No. 1801 Switchboards Systems A, B and C

#### Series Telephones

These telephones are recommended for use with No. 1801 switchboard systems A, B and C in local service only, that is, in connection with switchboards which do not have connection with an outside exchange. They are equipped with a direct current 140 ohm vibrating bell or buzzer, transmitter and receiver.



No. 1327H  
Systems "A" and "B"

#### WALL TELEPHONES

Code No.	Case and Finish	Mounting	Receiver	List Price Each
1327H	Wood—Golden oak*	Non-flush	Watch case type	\$12. 10
1339NM	Metal—Brush brass	Flush	Watch case type	18. 00
1333AY	Metal—Black enamel	Non-flush	Hand receiver	18. 30

\*Furnished in ebony finish at same price as oak finish.

#### DESK TELEPHONES

Code No.	Description	List Price Each
6034AU	Consists of a No. 1020BJ black desk stand equipped with a watch case receiver. Has a buzzer in the base. . . . .	\$22. 10
6034AT	Consists of a No. 1020BH black desk stand equipped with a watch case receiver. Has a separate direct current vibrating bell. . . . .	22. 10

#### Induction Coil Telephones

These telephones are recommended for use with No. 1801 switchboard systems "C," which have lines connecting the system or switchboard with an outside exchange. They are equipped with a direct current 140 ohm vibrating bell, induction coil, standard long distance transmitter and a bipolar hand receiver.

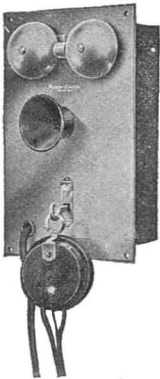

No. 1339 Type  
Systems "A" and "B"

#### WALL TELEPHONES

Code No.	Case and Finish	Mounting	List Price Each
1293AR	Wood—Golden oak	Non-flush	\$19. 80
1333S	Metal—Black enamel	Non-flush	23. 30

#### DESK TELEPHONES

Code No.	Desk Stand	Desk Set Box	List Price Each
6000AE	No. 1120CN (Black finish)	No. 295AU Non-flush (Golden oak finish)	\$26. 30

#### System D

Any standard central battery telephone with ringers operated by alternating current either induction coil or series type can be used with System D. However, induction coil apparatus, such as the No. 1333B wall telephones or No. 6032W desk telephones, are recommended where connection is made to an outside exchange.

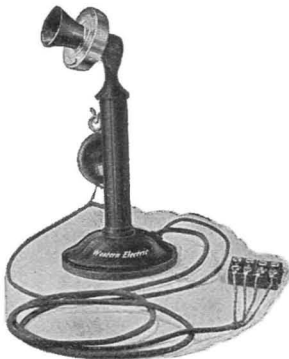

No. 6034AU. Systems "A" and "B"



No. 1333S. System "C"  
226



No. 6000AE. System "C"  
Telephone Apparatus and Supplies

## INTER-PHONES

"Inter-phones" is a trade name adopted by the Western Electric Company for what are generally known as intercommunicating telephones. They are special telephones designed to meet the requirements of service from room to room in a building or possibly from house to barn or garage. They have been designed by skilled telephone engineers especially for such use and are not adapted for outside telephone service.

### For the Information of Customers

Operating telephone companies, as a rule, do not permit connections with their wires, switchboards or telephones, of any apparatus or attachments not owned or maintained by them.

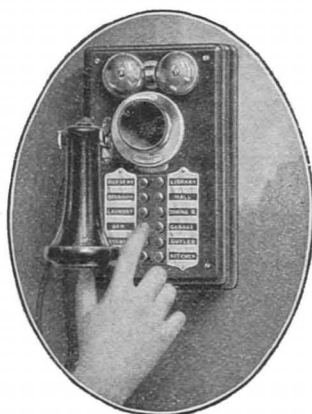

### Application

This apparatus is intended to provide telephonic communication between various points in the home, factory or plant, as for example:

In the home—between

Living-room  
Bedroom  
Library  
Nursery  
Servants' quarters  
Kitchen  
Stable or garage  
Etc.

In a business organization—between

President's office  
General manager  
Superintendent  
Bookkeeper  
Shipping clerk  
Foreman  
Cashier  
Etc.

### Operation

A combination formed by connecting together a number of Inter-phones is called an Inter-phone system.

Each system may be considered as a small private telephone exchange requiring neither switchboard nor operator. Communication—that is, ringing the station desired and conversing with the person answering—can be established by merely depressing a push button for a few seconds, holding the receiver to the ear and talking into the transmitter.

### Inter-phone Systems

To meet the different conditions in home and business, various Inter-phone systems have been designed, which differ in the number of instruments that can be connected, the kind of service they will give, the appearance of the sets—and the price. The quality of the apparatus for each system is of the highest and the difference in price is due to the fact that the service rendered by the various systems necessitates Inter-phones that differ in structure.

**INTER-PHONE SYSTEMS**

**Apparatus Required:**

All Western Electric Inter-phone systems are simple and consist primarily of the following apparatus:

- 1st: Inter-phones.
- 2d: Batteries to furnish current for ringing and talking.
- 3d: Wire or cable to connect Inter-phones and batteries.
- 4th: Installing material (usually furnished by the installer) for connecting and fastening Inter-phones, cable (or wire) and batteries.

**Types of Inter-phones:**

Three different types of Inter-phones to suit different conditions and tastes can be furnished:

- Wall Inter-phones**
- Desk Inter-phones**
- Hand Set Inter-phones**

which can be used interchangeably in the same system except when otherwise stated.

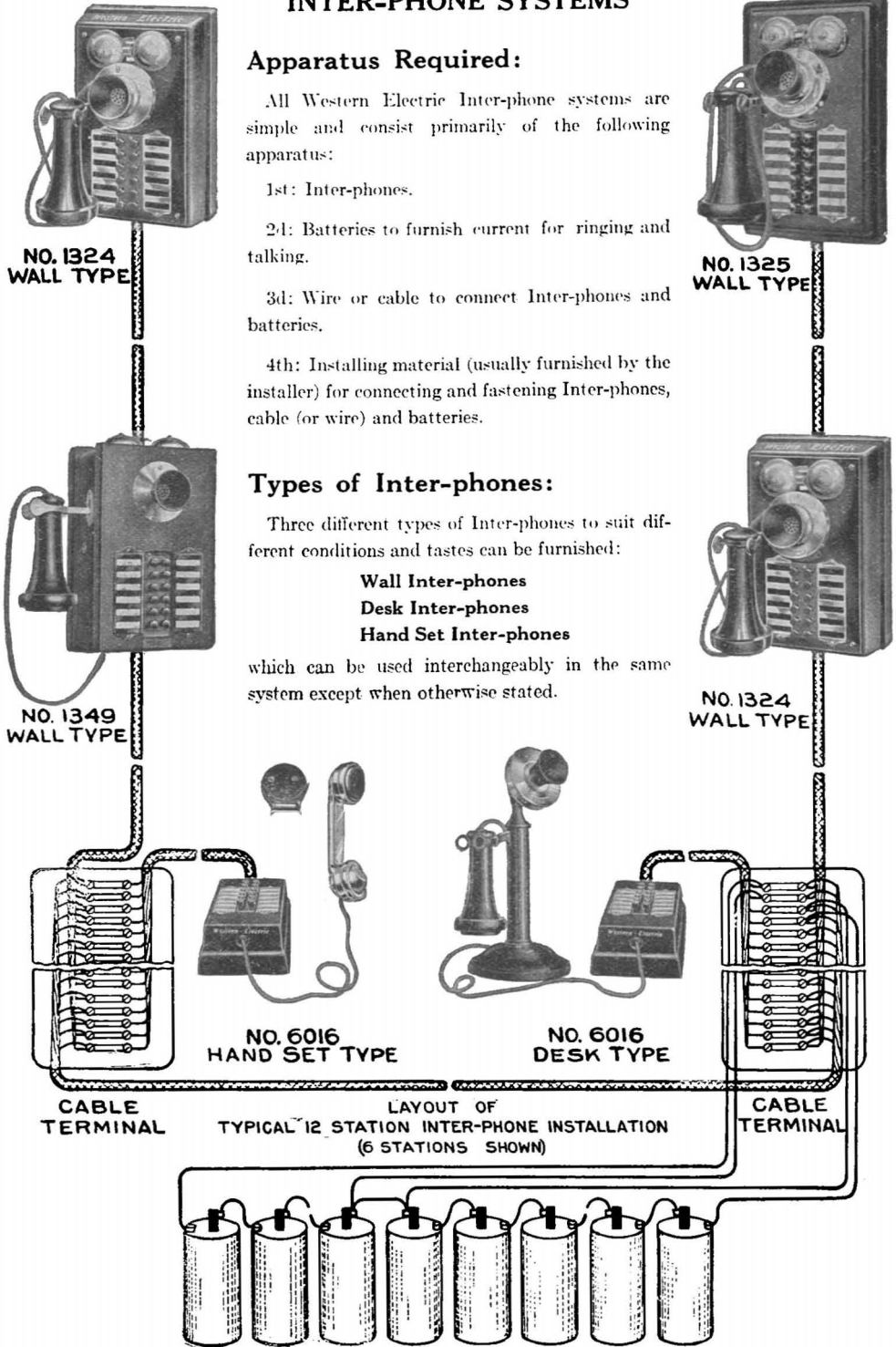

Telephone Apparatus and Supplies

## INTER-PHONE SYSTEMS

In order to assist our customers in selecting a system best adapted to their requirements the following list has been compiled:

### Inter-phone Systems Adapted to Business Organizations, Factories, Stores, Institutions, Large Residences, Etc., and to Meet the Following Requirements:

1. More Than One Conversation Can Take Place Simultaneously.
2. Any Station Can Ring Selectively Any Other Station in the System Instantaneously.
3. Quality of Apparatus, Operation, and Appearance, the Highest Grade Obtainable.

#### SYSTEM NO. 1

**3 Up to 24 Stations . . . . . Page 231**

The most comprehensive system manufactured. From any station it is possible to select, ring, and talk individually to any other station without disturbing the rest of the stations in the system. As many separate conversations can be carried on simultaneously as there are pairs of Inter-phones connected.

**Inter-phone Systems for Residences, Banks, Institutions, Warehouses, Stores, or Other Mercantile Establishments Where Conversations Are Less Frequent, Being Limited to One at a Time. The Systems Are Reliable in Operation, the Apparatus Pleasing in Appearance and Moderate in Cost.**

#### SYSTEM NO. 11

**3 Up to 12 Stations . . . . . Page 235**

From any station it is possible to select and ring any one of the other stations without disturbing the rest of the stations in the system. One conversation can be carried on at a time.

#### SYSTEMS NO. 12 AND NO. 16

**System No. 12—3 Up to 12 Stations . . . . . Page 238**

**System No. 16—3 Up to 24 Stations . . . . . Page 243**

Systems No. 12 and No. 16 consist of one centrally located Inter-phone called the "Master Station" to which are connected a number of other Inter-phones called "Outlying Stations."

From the Master Station it is possible to ring any one of the Outlying Stations selectively, or to ring the Master Station from each of the Outlying Stations. One conversation can be carried on at a time.

#### SYSTEM NO. 15

**2 Up to 6 Stations . . . . . Page 252**

A simple system. The bells of all stations will ring simultaneously whenever a call is made from any one of the stations. The various stations are called by signaling each one with a different code.

#### SYSTEM NO. 14

**2 Stations Only . . . . . Page 255**

Primarily recommended for connecting two points separated by a mile or less. Only two wires are required for connecting the two stations, either of which can ring and converse with the other.

## INTER-PHONE SYSTEMS

### Inter-phone Systems for Apartment Houses

#### SYSTEM NO. 7

7 Up to 25 Stations . . . . . **Page 257**

#### SYSTEM NO. 8

8 Up to 26 Stations . . . . . **Page 257**

#### SYSTEM NO. 9

9 Up to 27 Stations . . . . . **Page 258**

#### SYSTEM NO. 10

9 Up to 70 Stations . . . . . **Page 259**

These systems provide service for any combination of suite, vestibule, janitor's and tradesmen's Inter-phones. They differ from each other in their capacities and combinations.

From the vestibule, janitor and tradesmen stations it is possible to select, ring and talk individually to any of the other stations in the system (except between vestibule and tradesmen and vice versa).

#### SYSTEM NO. 20

4 or More Stations . . . . . **Page 266**

This system provides service for any combination of a number of suite Inter-phones, a vestibule Inter-phone, a janitor Inter-phone and a laundry Inter-phone. From the vestibule, janitor, and laundry stations any one of the suite stations can be selected and rung individually, and vice versa. One conversation can be carried on at a time in the system.

### Inter-phone Annunciator System

Consists of one centrally located annunciator with Inter-phone, called the "Master Station," connected to which are a number of other Inter-phones called "Outlying Stations."

#### SYSTEM NO. 18

10 Up to 70 Stations or More . . . . . **Page 271**

From the Master Station any one of the Outlying Stations can be rung selectively or the Master Station from any one of the Outlying Stations. Communication can be established between any two outlying stations through the medium of one or two connecting cords which can be used with the switchboard annunciator. Where many interconnections are required a private exchange switchboard of the No. 1801 type should be installed.

### Inter-phone Outfits

Complete Inter-phone systems of small capacities (2 or more) put up in standard packages containing Inter-phones, all necessary installing material, and complete instructions for mounting and wiring. **Page 275**

### Mechanical Code Signaling Systems

A call bell system making use of a number of mechanically revolving keys which when turned ring a number of bells simultaneously in accordance with a prearranged code. This calls to the telephone or central point persons to whom the code has been assigned. Fully described on pages **127 and 128**

**Telephone Apparatus and Supplies**

## INTER-PHONES System No. 1

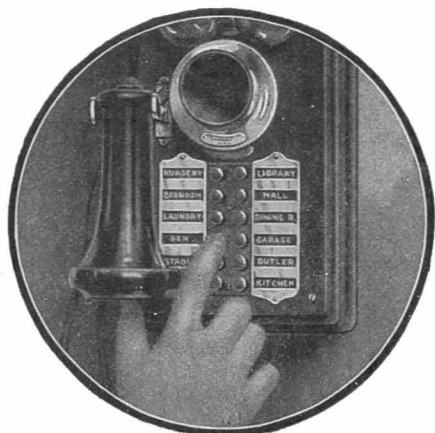

The No. 1 Inter-phone System is recommended for use in business organizations, factories, stores, institutions, large residences, etc., where frequently more than one conversation will take place at the same time; where prompt connections without loss of time are necessary and the highest grade of transmission is required.

The primary object in designing this system has been to obtain the BEST that can be made. Everything has been done to make the instruments as nearly perfect as possible, and the appearance and finish have been carefully studied with the result that they will harmonize with the surroundings under almost all conditions.

### OPERATION

From any station one can select and ring any other station without disturbing the rest of the stations in the system. That is, only the station wanted will be signaled and no other. This is done by means of

push button keys which are mounted in the face plates of the wall Inter-phones or in the key boxes used with desk stands or hand sets. For each station in the system, one push button key is required in each Inter-phone. Associated with the buttons are card holder frames to hold the cards which designate the names or station numbers of the buttons.

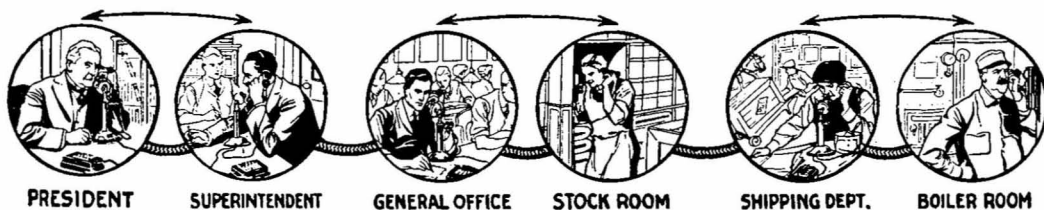

To make a call, the button, marked with the name or number of the station wanted, is pressed (thereby ringing the bell of that station).

Neither switchboard nor operator is required. The user makes his own connections, and is certain to get them right and without delay.

As many separate conversations can be carried on simultaneously as there are pairs of Inter-phones in the system. For example, in a system consisting of six Inter-phones, three separate conversations, as shown above, can be carried on at the same time without interfering with each other.

The class of service as described above is known as "Selective Ringing and Selective Talking" or "Non-interfering Service."

### PUSH BUTTON KEYS

The push button keys used in making calls are constructed to insure long life and positive operation. Each key consists of a plunger and a number of flexible springs fastened to a strong metal frame. The springs of each key are connected to one of the Inter-phones in the system.

When any one push button is completely depressed ("B"), certain spring contacts are made, causing the

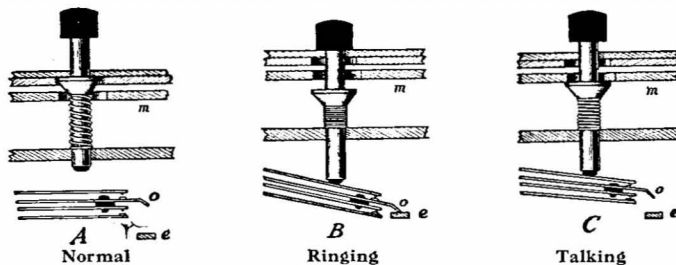

Normal, Ringing and Talking Position of Inter-phone Push Button Key

## INTER-PHONES

### System No. 1 (Continued)

#### PUSH BUTTON KEYS (Continued)

ringing current to flow to the station to which that particular key is connected, thereby ringing the bell at that station. When the push button is released, the plunger assumes an intermediate position ("C" bottom of page 231), breaking the ringing contact and clearing the line for conversation. While conversation is going on, the plunger is automatically held in the talking position by means of a locking plate. The operated key does not resume its normal position until another key is actuated. Talking current, however, is cut off as soon as the receiver is placed back on the switchhook.

#### CAPACITY

Inter-phones for System No. 1 are available in standard capacities of 6, 12, 16, 20 or 24 buttons. There can be as many Inter-telephone stations in a system as there are buttons in the Inter-phones.

#### TYPES OF INSTRUMENTS

Wall, desk and hand set Inter-phones can be used interchangeably in the same system.

### Wall Type Inter-phones



No. 1324 Type Wall Inter-telephone



No. 1325 Type Wall Inter-telephone

#### Metal Case with Dull Black Finish and Nickel Trimmings.

Code No.	Mounting	Capacity	List Price Each
1324F	Non-flush	6 buttons	\$36.20
1324A	Non-flush	12 buttons	41.10
Size of metal housing, 6 $\frac{3}{8}$ inches wide, 10 inches long, 3 $\frac{1}{8}$ inches deep.			
1325F	*Semi-flush	6 buttons	\$36.20
1325A	*Semi-flush	12 buttons	41.10
Size of metal housing, 6 $\frac{3}{8}$ inches wide, 10 inches long.			

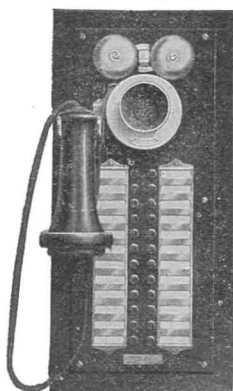

No. 1355 Type Wall Inter-telephone



No. 1349 Type Wall Inter-telephone

Code No.	Mounting	Capacity	List Price Each
1355A	*Flush	16 buttons	\$53.70
1355E	*Flush	20 buttons	57.80
1355F	*Flush	24 buttons	61.90
Size of face plate, 6 $\frac{7}{8}$ inches wide, 14 $\frac{1}{2}$ inches long.			
<b>Wooden Case with Golden Oak Finish and Black and Nickel Trimmings.</b>			
1349A	Non-flush	6 buttons	\$31.50
1349E	Non-flush	12 buttons	36.00
Size of cabinet, 6 $\frac{3}{8}$ inches wide, 9 $\frac{3}{4}$ inches long, 4 inches deep.			
1349F	Non-flush	16 buttons	\$42.80
1349G	Non-flush	20 buttons	46.50
1349H	Non-flush	24 buttons	50.30
Size of cabinet, 7 $\frac{5}{8}$ inches wide, 13 $\frac{1}{4}$ inches long, 4 inches deep.			

\*Metal wall box furnished.

## INTER-PHONES System No. 1 (Continued)

### Desk Type Inter-phones

#### Metal Key Box and Black Finish Desk Stand.

Key box dull black finish, provided with nickel trimmings and four rubber feet to keep the metal housing from scratching the table or desk. Cord between key box and desk stand is six feet long.



No. 6016 Type Desk Inter-phone

Code No.	Capacity	List Price Each
6016M	6 buttons	\$39.60
6016K	12 buttons	44.90
Size of key box, 5 inches wide, 7½ inches long, 2⅝ inches deep.		
6016N	16 buttons	\$53.60
6016P	20 buttons	57.70
6016L	24 buttons	61.90
Size of key box, 5¼ inches wide, 10¾ inches long, 2⅝ inches deep.		

### Hand Set Type Inter-phones

#### Metal Key Box, Nickel Plated Hand Set and Black Finish Hand Set Hanger.

Key box, dull black finish, provided with nickel trimmings and four rubber feet to keep the metal housing from scratching the table or desk. Cord between key box and hand set is six feet long.

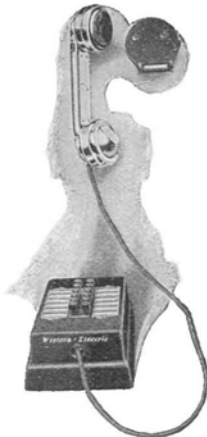

No. 6016 Type Hand Set Inter-phone

Code No.	Capacity	List Price Each
6016MH	6 buttons	\$50.20
6016KH	12 buttons	55.70
Size of key box, 5 inches wide, 7½ inches long, 2⅝ inches deep.		
6016NH	16 buttons	\$64.40
6016PH	20 buttons	68.50
6016LH	24 buttons	72.70
Size of key box, 5¼ inches wide, 10¾ inches long, 2⅝ inches deep.		

### Accessories for System No. 1

#### CABLE

For connections between the various stations, cable specially designed for Inter-phone work can be supplied. This cable includes the necessary number of wire conductors (two pairs for battery leads and one pair for each station in the system) and is furnished in three different types to suit various locations and conditions:

1. Cable with a gray braid covering, treated with fireproofing paint; for use in interiors where no dampness is ever present.
2. Cable with a green glazed cotton covering for interior use in dry locations where an attractive appearance is desired. (Usually in connection with desk and hand set Inter-phone stations.)
3. Cable with a lead covering for use out-of-doors and in locations where dampness even in a small degree is present or likely to be present.

	With Fireproofing Braid	With Green Cotton Braid	With Lead Covering
For a 6 station system . . . . .	Code No. 134	Code No. 155	Code No. 134
For a 12 station system . . . . .	Code No. 141	Code No. 156	Code No. 141
For a 16 station system . . . . .	Code No. 157	Code No. 159	Code No. 157
For a 20 station system . . . . .	Code No. 158	Code No. 160	Code No. 158
For a 24 station system . . . . .	Code No. 136	Code No. 150	Code No. 136

These cables are listed on page 52.

**INTER-PHONES**

**System No. 1 (Continued)**

**Accessories (Continued)**

**CABLE TERMINALS**

A cable terminal should be used wherever a junction is to be made between cables. For example: Where an outside lead-covered cable is connected to an interior cable, or wherever a branch is taken off from the main cable. In cases where the cable can be run direct to the Inter-phone, no cable terminal is necessary. The number of cable terminals required depends entirely upon local conditions and should be determined by the installer.

For 6 and 12 button systems use the No. 19A cable terminals.

For 16, 20 and 24 button systems use the No. 19B cable terminal.

Cable terminals are listed on page 55.

**BATTERIES**

Not more than 12 Blue Bell dry cells will be necessary for operating the system. (Five cells for the talking circuit; four to seven cells for the ringing circuit, depending upon length of line.)

The cells can be placed in the basement or any other accessible place.

Blue Bell dry cells are listed on page 17.

Detailed information covering wiring diagrams of system and Inter-phones, number and size of wires contained in cables, cable terminals, battery requirements, etc., can be found in our booklet, "Inter-phone Installing Instructions," which will be furnished upon request.

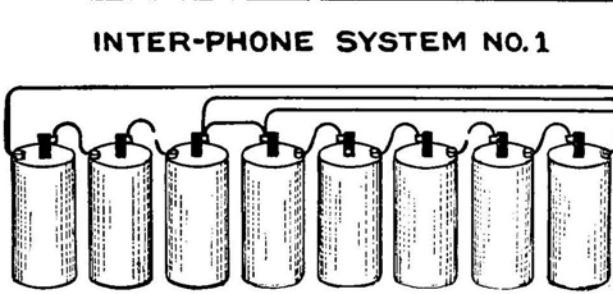

## INTER-PHONES

### System No. 11

The No. 11 Inter-phone system is recommended for use in residences, banks, institutions, warehouses, stores, or other mercantile establishments where conversations can be limited to one at a time.

The system is reliable in operation and the apparatus is pleasing in appearance and moderate in cost.

#### OPERATION



Each Inter-phone in the system is equipped with a number of push buttons for signaling the other stations. Associated with the buttons are card holder frames to hold cards designating the name or station number of the buttons. By depressing the button marked with the name or number of the station wanted, the bell of that station will be rung. No other station in the system will be signaled but the one desired.

Summarizing the service:

**From Any One Station in the System Any Other Station in the System Can Be Selected and Rung Without Disturbing Those Stations That Are Not Wanted, and**

**Only One Conversation Can Be Carried on at a Time**

Each No. 11 system requires one Battery Station, which should be located near the battery. The other stations in the system should be of the Non-battery Station type. For example, in a system consisting of five stations, there should be one battery station and four non-battery stations.

THIS DIAGRAM IS INTENDED TO SHOW THE RINGING SERVICE PROVIDED BY 5-FOUR BUTTON SETS OF SYSTEM NO. 11 AND SHOULD NOT BE CONFUSED WITH THE WIRING DIAGRAM

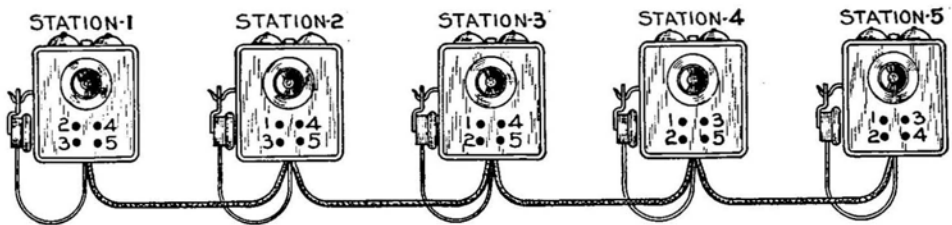

EACH SET REQUIRES ONE BUTTON FOR EACH OTHER STATION IN THE SYSTEM, THUS-4 BUTTON SETS WILL PROVIDE FOR A 5 STATION SYSTEM. STATION #1 CAN RING STATIONS 2,3,4 & 5; STATION #2 CAN RING STATIONS 1,3,4 AND 5 - ETC. - SEE MARKING ON PUSH BUTTONS IN DIAGRAM ABOVE.

The class of service described under this system is known as *Selective Ringing and Common Talking*.

#### CAPACITY

The standard Inter-phones are equipped with 4, 8 and 12 buttons, accommodating the following number of stations in a system:

4 button	—	5 stations.
8 button	—	9 stations.
12 button	—	13 stations.

#### TYPES OF INSTRUMENTS

Wall, desk and hand set Inter-phones can be used interchangeably in the same system.

## INTER-PHONES

### System No. 11 (Continued)

#### Wall Type Inter-phones

**Wooden Case with Golden Oak Finish and Nickel Trimmings.**

Code No.	Mounting	Capacity	Used for	List Price Each
1327J	Non-flush	4 buttons	Battery station	\$19.00
1327K	Non-flush	4 buttons	Non-battery station	18.20
1327L	Non-flush	8 buttons	Battery station	20.70
1327M	Non-flush	8 buttons	Non-battery station	19.80

Size of cabinet 5 $\frac{3}{4}$  inches wide, 6 $\frac{7}{8}$  inches long, 3 $\frac{1}{4}$  inches deep.

**Metal Case with Brush Brass Finished Face Plate and Metal Wall Box**

Code No.	Mounting	Capacity	Used for	List Price Each
1339B	*Flush	4 buttons	Battery station	\$25.80
1339C	*Flush	4 buttons	Non-battery station	24.80
1339D	*Flush	8 buttons	Battery station	\$32.40
1339E	*Flush	8 buttons	Non-battery station	31.40

Size of face plate 5 $\frac{1}{16}$  inches wide, 8 $\frac{1}{16}$  inches long.

Size of face plate 5 $\frac{1}{16}$  inches wide, 9 $\frac{3}{16}$  inches long.

**Metal Case with Dull Black Finish and Nickel Trimmings**

Code No.	Mounting	Capacity	Used for	List Price Each
1324J	Non-flush	12 buttons	Battery station	\$30.70
1324S	Non-flush	12 buttons	Non-battery station	On request
1325M	*Semi-flush	12 buttons	Battery station	\$30.70
1325E	*Semi-flush	12 buttons	Non-battery station	On request

Size of face plate 6 $\frac{3}{8}$  inches wide, 10 inches long.

\*Metal wall box furnished.

#### Desk Type Inter-phones

**Desk Stand—Black Finish, with Push Buttons in Base. Complete with Bell, Terminal Block, 6 Foot Cord, etc.**

Code No.	Capacity	Used for	List Price Each
6034R	4 buttons	Battery station	\$27.50
6034M	4 buttons	Non-battery station	26.10
6034N	8 buttons	Battery station	31.20
6034P	8 buttons	Non-battery station	29.90

**Desk Stand—Black Finish, Without Push Buttons in Base. Signaling Equipment Mounted in a Separate Dull Black Finish Metal Box Connected to the Desk Stand by Means of a Six-Foot Cord.**

The push button box is provided with four rubber feet to keep the metal housing from scratching the table or desk.

Code No.	Capacity	Used for	List Price Each
6016R	12 buttons	Battery station	\$37.60
6016SD	12 buttons	Non-battery station	36.60

Size of push button box 5 inches wide, 7 $\frac{1}{2}$  inches long, 2 $\frac{3}{8}$  inches deep.

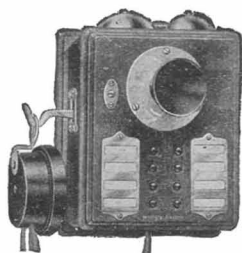

No. 1327 Type Wall Inter-telephone



No. 1339 Type Wall Inter-telephone



No. 1324 Type Wall Inter-telephone



No. 1325 Type Wall Inter-telephone

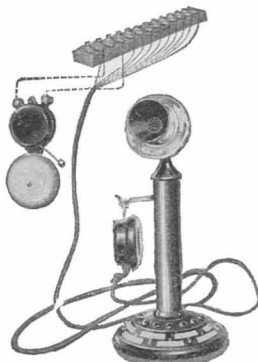

No. 6034 Type Desk Inter-telephone



No. 6016 Type Desk Inter-telephone

## INTER-PHONES

### System No. 11 (Continued)

#### Hand Set Type Inter-phones



No. 6034 Type Hand Set Inter-phone



No. 6016 Type Hand Set Inter-phone

This presents one of the most convenient types of talking equipment. The transmitter and receiver are a part of the hand set, which is held and operated with one hand, leaving the other free. A bar marked "Press to Talk" is mounted in the hand set handle and is held down by the natural position of the hand while conversing. When not in use, the hand set can be hung on a hook or laid down in any position. The finish of the hand set is black.

These Inter-phones are complete, and include a wooden push button block, bell, terminal block, etc. The cord connecting the terminal block to the push button block is six feet long.

Code No.	Capacity	Used for	List Price Each
6034AY	4 buttons	Battery station	\$19.70
6034AZ	4 buttons	Non-battery station	18.40
6034BA	8 buttons	Battery station	23.10
6034BB	8 buttons	Non-battery station	21.80

Another combination consists of the black finish hand set, described above, and a dull black finish metal push button box, which includes push buttons, buzzer, terminals, etc., and is provided with nickel trimmings and four rubber feet to keep metal housing from scratching the table or desk. Cord between push button box and hand set is three feet long.

6016AA	12 buttons	Battery station	\$30.30
6016SH	12 buttons	Non-battery station	29.30

Size of push button box 5 inches wide, 7½ inches long, 2½ inches deep.

#### Accessories for System No. 11

##### CABLE

For connection between the various stations, cable especially designed for Inter-phone work can be furnished. This cable includes the necessary number of wire conductors (3 common wires and 1 individual wire for each station) and is furnished in three different types to suit various locations and conditions.

1. Cable with green braid covering, treated with fireproofing paint for use in interiors where no dampness is ever present.
2. Cable with green glazed cotton covering for interior use in dry locations where an attractive appearance is desired. (Usually in connection with desk and hand set Inter-phone stations.)
3. Cable with a lead covering for use out-of-doors and in locations where dampness even in a small degree is present or likely to be present.

	With Fireproofed Braid	With Green Cotton Braid	With Lead Covering
For a 4 button system . . . . .	Code No. 161	Code No. 142	Code No. 161
For an 8 button system . . . . .	Code No. 162	Code No. 163	Code No. 162
For a 12 button system . . . . .	Code No. 134	Code No. 155	Code No. 134

These cables listed on page 52.

#### CONNECTING BLOCKS

Where a junction is to be made between cables, as for example, where an outside lead covered cable is to be connected to an interior cable, or wherever a branch is taken off from the main cable, a connecting block should be used as shown in diagram. In cases where the cable can be run direct to the Inter-phone the connecting block is not necessary. The number of connecting blocks required depends entirely upon local conditions and should be determined by the installer.

- For 4 and 8 button systems use connecting block 6A.
- For 12 button systems use connecting block 6B.
- Connecting blocks are listed on page 58.

#### BATTERIES

Five Blue Bell dry cells are required for the operation of this system, when the distance between the two sets farthest apart is 750 feet or less, and Inter-phone cable, listed above, is used. On lines of greater length it is recommended that instead of increasing the number of battery cells to more than five, larger wire be used. This should be determined by the installer in accordance with the information furnished in the booklet, "Inter-phone Installing Instructions." The Blue Bell dry cells can be placed in the basement or any other accessible place. Blue Bell dry cells are listed on page 17.

Detailed information covering wiring diagrams of system and Inter-phones, number and size of wires contained in cables, connecting blocks, battery requirements, etc., can be found in the booklet, "Inter-phone Installing Instructions," which will be furnished upon request.

## INTER-PHONES

### System No. 12

The No. 12 Inter-phone system consists of one centrally located Inter-phone called the "Master Station," to which a number of other Inter-phones, known as "Outlying Stations," are connected. This system is adapted for the same class of service as outlined under the No. 16 system, and provides communication from a central point to different rooms, and vice versa. It differs from the No. 16 system in that wall, desk or hand set Inter-phones can be used interchangeably in the same system, whereas the No. 16 system makes use of hand sets only.

#### OPERATION

The master station is equipped with a number of push buttons, one for each outlying station in the system. Associated with the buttons are card holder frames to hold cards designating the name or station number of the buttons. By depressing the button marked with the name or number of the outlying station wanted, the bell of that station will be rung. No other Inter-phone in the system will be signaled but the one desired.

The outlying stations are equipped with only one button, which will signal the master station when depressed.

#### SERVICE

The service provided by Inter-phone System No. 12 is called "two-way service" which signifies that it is possible to *select and ring individually any one of the outlying stations from the master station, and vice versa, and any one of the outlying stations can call the master station.* No provision is made for having the outlying stations call one another. If this feature is desired systems No. 1, 11 or 15 should be used.

*Only one conversation can be carried on at a time.*

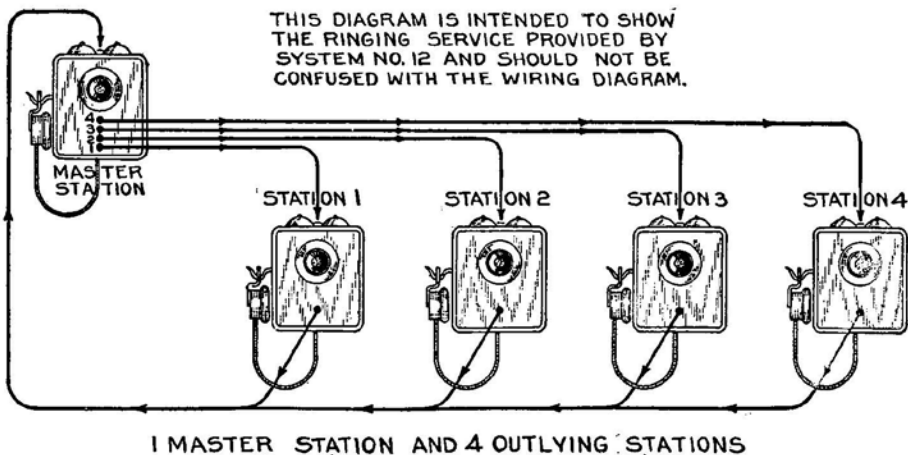

#### CAPACITY

One master station and from two to twelve outlying stations can be connected.

#### TYPES OF INSTRUMENTS

Wall, desk and hand set type Inter-phones can be used interchangeably in the same system.

## INTER-PHONES

### System No. 12 (Continued)

### Master Stations

#### WALL INTER-PHONES

##### Wooden Case with Golden Oak Finish and Nickel Trimmings

Code No.	Mounting	Capacity	List Price Each
1327W	Non-flush	4 buttons	\$19.00
1327Y	Non-flush	8 buttons	20.70

Size of cabinet  $5\frac{3}{4}$  inches wide,  $6\frac{7}{8}$  inches long,  $3\frac{1}{4}$  inches deep.

##### Metal Case with Brush Brass Finished Face Plate and Metal Wall Box

Code No.	Mounting	Capacity	List Price Each
1339F	*Flush	4 buttons	\$25.80

Size of face plate  $5\frac{1}{8}$  inches wide,  $8\frac{1}{8}$  inches long.

1339G	*Flush	8 buttons	32.40
-------	--------	-----------	-------

Size of face plate  $5\frac{1}{8}$  inches wide,  $9\frac{3}{16}$  inches long.

##### Metal Case with Dull Black Finish and Nickel Trimmings

Code No.	Mounting	Capacity	List Price Each
1324J	Non-flush	12 buttons	\$30.70

Size of metal housing  $6\frac{3}{8}$  inches wide, 10 inches long,  $3\frac{1}{8}$  inches deep.

1325M	*Semi-Flush	12 buttons	\$30.70
-------	-------------	------------	---------

Size of face plate  $6\frac{3}{8}$  inches wide, 10 inches long.

\*Metal wall box furnished.

#### DESK INTER-PHONES

##### Desk Stand—Black Finish, with Push Buttons in Base. Complete, with Terminal Block, Six-foot Cord, etc.

Code No.	Capacity	List Price Each
6034L	4 buttons	\$27.40
6034S	8 buttons	31.20

##### Desk Stand—Black Finish, but Without Push Buttons in Base.

Signaling equipment is mounted in a separate, dull black finish, metal box connected to the desk stand by means of a six foot cord. The push button box is provided with four rubber feet to keep the metal housing from scratching the table or desk.

Code No.	Capacity	List Price Each
6016R	12 buttons	\$37.60

Size of push button box 5 inches wide,  $7\frac{1}{2}$  inches long,  $2\frac{5}{8}$  inches deep.



No. 1327 Type Wall Inter-telephone



No. 1339 Type Wall Inter-telephone



No. 1324 Type Wall Inter-telephone



No. 1325 Type Wall Inter-telephone

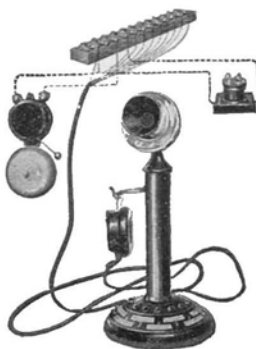

No. 6034 Type Desk Inter-telephone  
239



No. 6016 Type Desk Inter-telephone Telephone Apparatus and Supplies

INTER-PHONES

System No. 12 (Continued)

Master Station (Continued)

HAND SET INTER-PHONES

This presents one of the most convenient types of talking equipment. The transmitter and receiver are a part of the hand set, which is held and operated with one hand, leaving the other free. A bar marked "Press to Talk" is mounted on the handle and is depressed by the natural position of the hand while conversing. When not in use the hand set can be hung on a hook or laid down in any position. The hand set is finished in black.

The signaling equipment for the master station hand sets is of two kinds. The four and eight station Inter-phones have the signaling buttons mounted in an oak block. The bell, connecting block, etc., must be mounted separately. A 6 foot cord connects the terminal block to the push button block.

The twelve-station Inter-phones have a metal key box which contains all the signaling apparatus and is connected to the hand set by means of a cord.

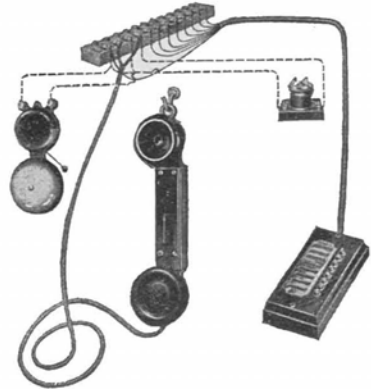

No. 6034 Type Hand Set Inter-phone



No. 6016 Type Hand Set Inter-phone

Code No.	Capacity	List Price Each
6034BC	4 buttons	\$19.70
6034BD	8 buttons	23.10
6016AA	12 buttons	30.30

Size of 12 button push button box 5 inches wide, 7½ inches long and 2⅝ inches deep.

Outlying Stations

WALL INTER-PHONES

Wooden Case with Golden Oak Finish and Nickel Trimmings.

Code No.	Mounting	List Price Each
1327U	Non-flush	\$10.50

Size of cabinet 5¾ inches wide, 6⅞ inches long, 3¼ inches deep.

Metal Case with Brush Brass Finished Face Plate and Metal Wall Box.

Code No.	Mounting	List Price Each
1339H	*Flush	\$13.20

Size of face plate 5⅞ inches wide, 8⅞ inches long.  
\*Metal wall box furnished.

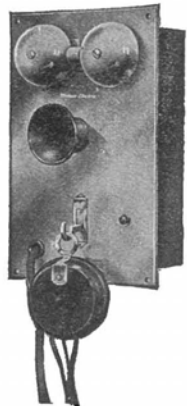

No. 1339 Type Wall Inter-phone



No. 1327 Type Wall Inter-phone

**INTER-PHONES**

**System No. 12 (Continued)  
Outlying Stations (Continued)**

**DESK INTER-PHONES**

**Desk Stand—Black Finish.** The Signaling Equipment Is Mounted in Separate Oak Cabinet. Cord Connecting Desk Stand to Cabinet, 6 Feet Long.



No. 6015 Type Desk Inter-phone

Code No.	List Price Each
6015L	\$23.60

**Desk Stand—Black Finish, with Push Button in Stem, and Buzzer in Base. Includes terminal block and Six Foot Cord.**

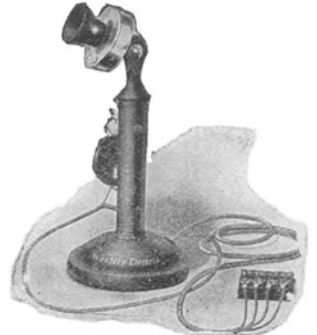

No. 6034 Type Desk Inter-phone

Code No.	List Price Each
6034AP	\$25.60

**HAND SET INTER-PHONES**

The types of hand sets furnished with the outlying stations are the same as described under "Master Stations." For the outlying stations it is necessary to use apparatus boxes containing terminals and other accessories.

Two types of apparatus boxes can be furnished.

1. Round boxes arranged for non-flush mounting, with black finished metal cover and nickel-plated hook; approximate size of box 3 1/8 inches diameter by 1 5/8 inches deep.
2. Metal boxes arranged for flush mounting, intended to be set in the wall and equipped with brush brass finished face plate. See note 2 at the bottom of page 243.

With the non-flush apparatus box, the hand set cord is permanently attached to the hand set and box. With the flush mounted apparatus box the hand set cord terminates in a plug. This plug can be inserted into a receptacle in the center of the face plate just below the push button, thereby connecting the hand set to the system. By removing the hand set, telephone service can be discontinued at any point. Furthermore, one hand set can be carried from station to station and used wherever there is a flush apparatus box.

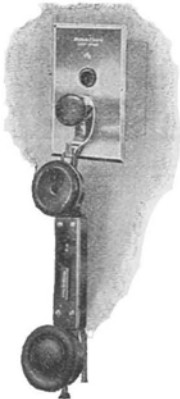

No. 6042K  
Hand Set Inter-phone

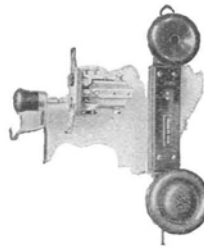

No. 6042E  
Hand Set Inter-phone



No. 6043E  
Hand Set Inter-phone

Code No.	Mounting	List Price Each
6042K	Flush	\$17.90
*6042E	Flush	17.20
6043E	Non-flush	15.20

\*No. 6042E is same as No. 6042K, but without face plate and wall box. See note 2 at the bottom of page 243.

## INTER-PHONES

### System No. 12 (Continued)

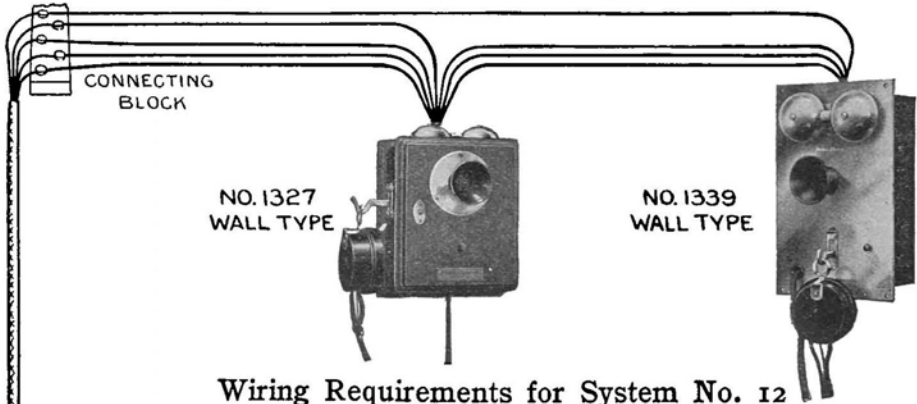

### Wiring Requirements for System No. 12

For connections between the outlying stations and the master station either cable or loose wires can be used, depending largely upon the layout of the system. There will be three wires, common to all stations, required in the system, and in addition, one individual wire from the master to each outlying station. Where there is a long run of a large number of wires, it will be found economical to use cable, and at all distributing and junction points, to install connecting blocks. From these connecting blocks separate wires can be run to the Inter-phones. The sizes of cable and the number of connecting blocks required should be determined by the installer in accordance with the information furnished in our booklet, "Inter-phone Installing Instructions."

Cables are listed on page 52.

Connecting blocks are listed on page 58.

### Battery Requirements for System No. 12

Five Blue Bell dry cells are required for the operation of this system when the distance between the master station and most distant outlying station is 750 feet or less and No. 22 B.&S. gauge wire (as in the case of Western Electric cable) is used.

On lines of greater length it is recommended that instead of increasing the number of battery cells to more than five, larger wire be used. This should be determined by the installer in accordance with the information furnished in our booklet, "Inter-phone Installing Instructions."

The Blue Bell dry cells can be placed in the basement or any other accessible place.

Blue Bell dry cells are listed on page 17.

Detailed information covering wiring diagrams of system and Inter-phones, number and size of wires contained in cables, connecting blocks, etc., can be found in our booklet, "Inter-phone Installing Instructions," which will be furnished upon request.

### INTER-PHONE SYSTEM NO. 12

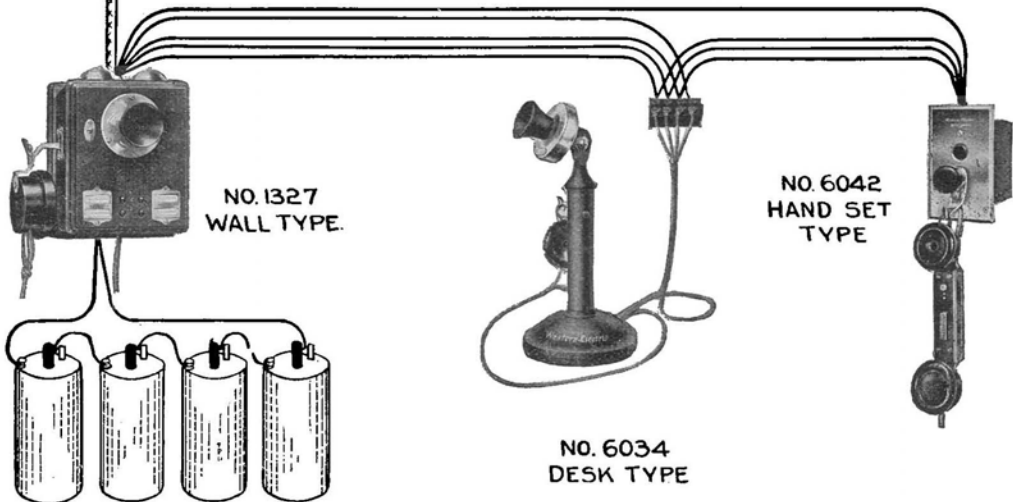

## INTER-PHONES

### System No. 16

#### General

The No. 16 Inter-phone system consists of one centrally located Inter-phone called the "Master Station" connected to a number of other Inter-phones called "Outlying Stations." This system is particularly adapted to residences, country places, hotels, hospitals, schools, etc., where it is desired to communicate from a central point to various rooms, and vice versa; for example:

In residences for calling a central point, such as the kitchen or pantry, from the living-room, bedroom, garage, laundry, vestibule, attic, etc.;

In apartment houses for dumb-waiter service, where telephonic communication is desired between the tradesmen at the foot of the dumb-waiter shaft and the apartments;

In stores, offices, banks, where a number of people must frequently consult with the department heads, and vice versa;

In schools where the principal desires to call the teachers individually and the teachers to call him, but not to call each other;

In hospitals where the house doctor or head nurse may be wanted in a hurry;

In prisons or asylums where the superintendent, warden or other officials are likely to be summoned suddenly.

Special attention is directed to system No. 16B, which is adapted for use in place of ordinary push-button and annunciator systems, as it provides not only ringing service but also telephone service in the simplest and most economical manner. (See description of system No. 16B for details.)

#### Service

Three kinds of ringing service are possible with system No. 16. They are designated as Nos. 16A, 16B and 16C. Any one can be obtained by specifying appropriate equipment.

**No. 16A: One-Way Service, Master Station Can Call Outlying Stations.** Any one of the outlying stations can be called from the master station. No other Inter-phone in the system will be signaled but the one desired. The outlying stations cannot ring the master station.

**No. 16B: One-Way Service, Outlying Stations Can Call Master Station.** Any one of the outlying stations can ring the master station, but the master station cannot ring the outlying stations.

**No. 16C: Two-Way Service.** This is a combination of No. 16A and 16B in which any one of the outlying stations can ring the master station and the master station can ring any one of the outlying stations. No other Inter-phone in the system will be signaled but the one desired.

**Only One Conversation Can Be Carried on at a Time**, no matter what class of ringing service is to be used. No provision is made for having the outlying stations call one another. If this feature is desired, systems Nos. 1, 11 or 15 should be used.

#### Capacity

One master station and any number of outlying stations, up to 24, can be installed with any one of the three systems. Additional outlying stations can be provided if desired.

#### Types of Instruments

##### Hand Sets

Only the hand set type of Inter-phone can be used with system No. 16. This represents one of the most convenient types of talking equipment. The transmitter and receiver are a part of the hand set, which can be held and operated with one hand, leaving the other free. A bar marked "Press to talk" is mounted on the hand set handle and is held down by the natural position of the hand while talking. When not in use, the hand set can be hung on a hook or laid down in any position. The hand set is finished in black.

##### Apparatus Boxes

In connection with the hand set it is necessary to use apparatus boxes containing terminals and other accessories. Two types of apparatus boxes can be furnished.

1. Round boxes arranged for non-flush mounting and equipped with an insulated base, black finished metal cover and nickel hook. Approximate size  $3\frac{1}{8}$  inches in diameter by  $1\frac{1}{8}$  inches deep.

2. Metal boxes arranged for flush mounting, intended to be set in wall and equipped with a brush brass finished face plate. These boxes consist of three parts—a type AA Union sectional switchbox, a No. 382 apparatus unit and a No. 12007 face plate. The face plate is  $4\frac{1}{2} \times 2\frac{3}{4}$  inches, the wall box  $2 \times 3 \times 3$  inches deep. (Continued on next page.)

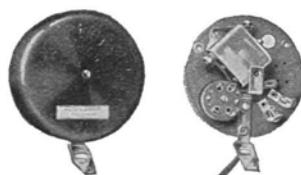

No. 383 Type Apparatus Box  
Non-flush Mounting

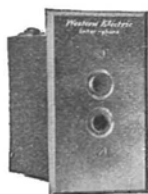

No. 382 Type Apparatus Box  
Flush Mounting

## INTER-PHONES

### System No. 16 (Continued)

#### Types of Instruments (Continued)

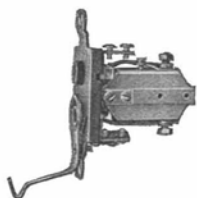

No. 382 Type Apparatus Unit



Face Plate No. 12007

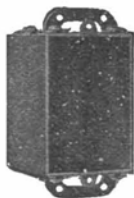

Type AA Union Sectional Switch Box

An important point to be observed is that box and face plate are the same as those used in electric light wiring for push button switches. This feature is of special importance to the contractor, since it allows him to draw on his own stock of Union sectional switchboxes and face plates. For this reason we are prepared to furnish sets either complete, including box and plate, or minus these parts.

#### Flexibility

With the non-flush apparatus box, the hand set cord is permanently attached to the hand set and box. With the flush mounted apparatus box the hand set cord is not permanently attached to the box, but terminates in a plug (except with No. 6042L and G, System No. 16-B.) This plug can be inserted into a receptacle located in the center of the face plate just below the push button, thereby connecting the hand set to the system. This feature makes it possible to discontinue telephone service at any point by simply removing the plug and the hand set. A hand set can be carried around from room to room to serve as an outlying station at any place where a flush apparatus box is located. The plug is equipped with a hook on which the hand set can be hung when not in use.



### System No. 16-A

#### PROVIDING ONE-WAY SERVICE

##### Master Station Can Call Outlying Stations

The master station may consist of a hand set with either a flush or a non-flush mounted apparatus box, and a push button block, with as many push buttons as there are outlying stations to be called. Associated with the buttons are card holder frames for holding cards to designate the name or station number of each button.

THIS DIAGRAM IS INTENDED TO SHOW THE RINGING SERVICE PROVIDED BY SYSTEM NO. 16A AND SHOULD NOT BE CONFUSED WITH THE WIRING DIAGRAM

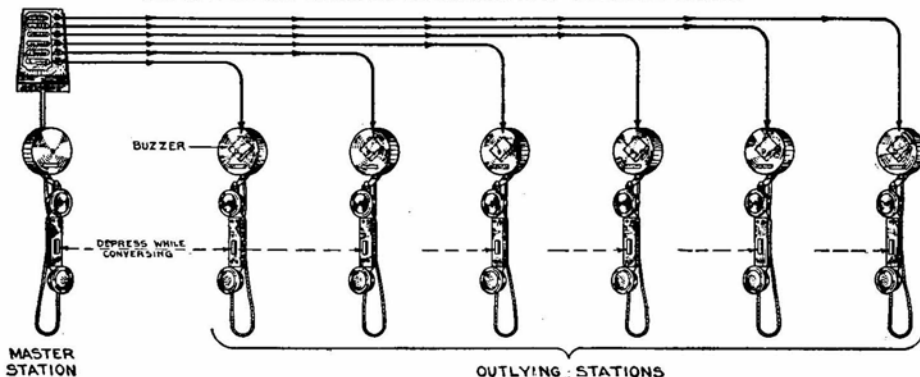

## INTER-PHONES

### System No. 16-A (Continued)

To call an outlying station from the master station, the button marked with the name or number of the station wanted must be depressed. This will operate the buzzer at the outlying station. No other Inter-telephone in the system will be signaled but the one desired. Conversation can be carried on by depressing the talking bar in the hand set handle. In this system the outlying stations cannot call the master station nor can the outlying stations call one another.

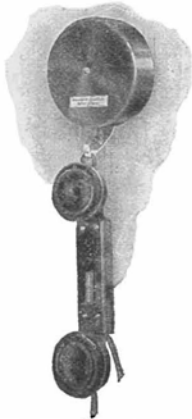

**No. 6043 Type Master or Outlying Station**

#### MASTER STATION

This consists of either a flush or non-flush type apparatus box, black finished hand set and three-foot cord.

Code No.	Mounting	List Price Each
6042AA	Flush	\$14.20
6042AB*	Flush	13.50
6043L	Non-flush	10.70

\*No. 6042AB is the same as No. 6042AA, but without face plate and wall box. See note 2 at the bottom of page 243.



**No. 6042 Type Master or Outlying Station**

#### Push Button Blocks

In addition to the master station hand set one of the following push button blocks must be used. The number of push buttons required depends upon the number of outlying stations in the system.

Code No.	Number of Buttons (One per Outlying Station)	List Price Each
4A	4	\$3.60
6A	6	3.90
8A	8	5.00
10A	10	6.00
12A	12	7.20
14A	14	8.40
16A	16	9.60
20A	20	11.50

#### OUTLYING STATIONS

These consist of either the flush or non-flush type apparatus box with black finished hand set and three-foot cord.

Code No.	Mounting	List Price Each
6042AC	Flush	\$15.90
6042AD*	Flush	15.10
6043M	Non-flush	12.50

\*No. 6042AD is the same as No. 6042AC but without face plate and wall box. See note 2 at the bottom of page 243.

#### WIRING AND BATTERY REQUIREMENTS

##### For System No. 16-A

There must be two wires common to all stations in the system and, in addition, one individual wire from the master station to each of the outlying stations.

Only one battery is required for the operation of the system. This consists of three to four Blue Bell dry cells on lines where the distance between the master station and the farthest outlying station is 200 feet or less and No. 22 B.&S. gauge copper wire is used.

## INTER-PHONES

### System No. 16-A (Continued)

#### WIRING AND BATTERY REQUIREMENTS (Continued)

On lines of greater length, it is recommended that instead of increasing the number of dry cells to more than four, larger wires be used, as follows:

250 to 400 feet use No. 20 B.&S. gauge copper wire.

400 to 600 ft. use No. 18 B.&S. gauge copper wire.

600 to 1000 ft. use No. 16 B.&S. gauge copper wire.

Detailed information covering wiring diagrams of system and Inter-phones can be found in our booklet, "Inter-phone Installing Instructions," which will be furnished upon request.

### System No. 16-B

#### PROVIDING ONE-WAY SERVICE

##### Outlying Stations Can Call Master Station

THIS DIAGRAM IS INTENDED TO SHOW THE RINGING SERVICE PROVIDED BY SYSTEM NO.16-B AND SHOULD NOT BE CONFUSED WITH THE WIRING DIAGRAM

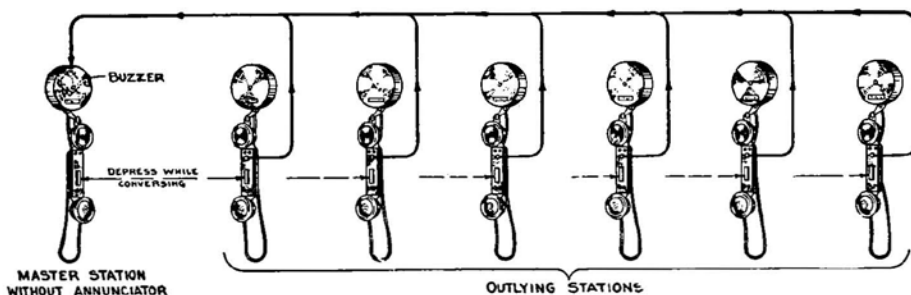

The master station may consist of a hand set with either a flush or non-flush mounted apparatus box, or a hand set and an annunciator. The outlying stations may consist of a hand set with either a flush or a non-flush mounted apparatus box.

THIS DIAGRAM IS INTENDED TO SHOW THE RINGING SERVICE PROVIDED BY SYSTEM NO. 16-B AND SHOULD NOT BE CONFUSED WITH THE WIRING DIAGRAM

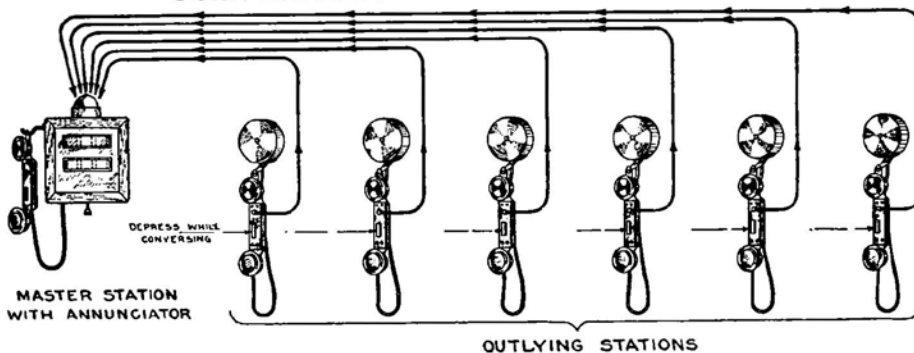

Each outlying station is provided with a push button, which when depressed will signal the master station. If the master station consists of a hand set and apparatus box, there will be nothing to indicate which outlying station originated the call. If such an indicating arrangement is desired, an annunciator, equipped with as many drops as there are outlying stations, is required in place of the apparatus box. Each call from the outlying stations will then be registered by the operation of one of the drops, thereby indicating what outlying station signaled. Conversation can be carried on by depressing the talking bar in the hand set handle.

The master station cannot call the outlying stations, nor can the outlying stations signal each other.  
Telephone Apparatus and Supplies

## INTER-PHONES

## System No. 16-B (Continued)

This system is specially designed to replace the ordinary annunciator and push button systems. It requires the same number of wires and the apparatus may be used either with or without telephones. The following diagrams illustrate the simplicity of this system, showing how telephone service may be obtained over the same number of wires with simple and inexpensive apparatus:

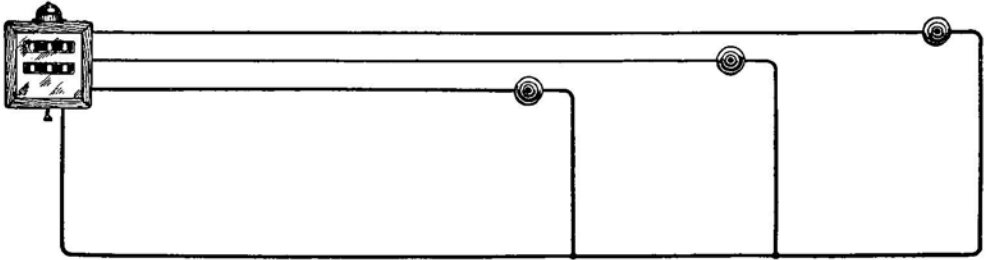

Fig. 1  
Showing Wiring and Equipment of an Ordinary Annunciator and Push Button System

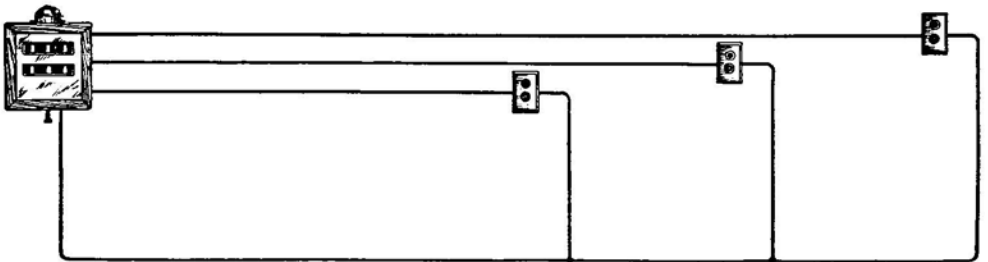

Fig. 2  
Showing the No. 382CB Flush Type Apparatus Box Used in Place of Push Buttons. The Annunciator Is One of the No. 360009 to No. 360017 Type Illustrated on Page 22

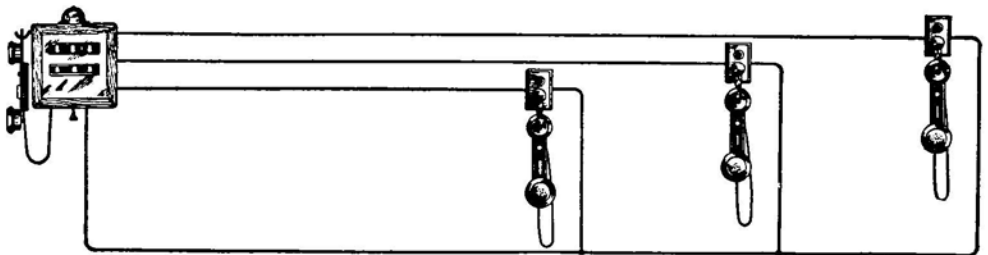

Fig. 3  
Showing How Easily the Added Convenience of Telephone Service Is Obtained by Merely Plugging a No. 1003F Hand Set Into the Apparatus Box and Adding a No. 1003D Hand Set to the Annunciator

## EXTENSION CORD

The standard hand set cord is three feet long. Longer cords are often needed as in case of illness or for other reasons so that the hand sets can be used in bed or any other point some distance from the apparatus box. In such cases hand sets for outlying stations can be furnished provided for or equipped with an extension cord in addition to the standard three-foot hand set cord. Each extension cord is eight feet long and as many extension cords can be connected as desired. See page 251.

## INTER-PHONES

### System No. 16-B (Continued)

#### MASTER STATION WITHOUT ANNUNCIATOR

This consists of either a flush or non-flush type apparatus box equipped with a black finished hand set and three-foot cord. No plug is furnished with the flush type Inter-telephone, as the cord is permanently attached to the apparatus box.



**No. 6043 Type  
Master Station**

Code No.	Mounting	List Price Each
6042L	Flush	\$15.10
*6042G	Flush	14.40
6043N	Non-flush	12.70

\*No. 6042G is the same as No. 6042L, but without face plate and wall box. See Note 2 at the bottom of page 243.



**No. 6042 Type  
Master Station**

#### MASTER STATION WITH ANNUNCIATOR

In this case the master station consists of a black finished hand set with three-foot cord and an annunciator with hook for holding the hand set. Annunciator and hand set must be ordered separately.

#### Annunciators

Any one of the following annunciators may be used depending upon the number of outlying stations for which service is to be provided. The finish of the annunciators is golden oak. Light or dark oak finish will, however, be furnished without additional charge.

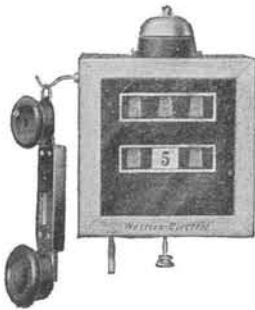

**No. 360011  
Master Station  
One-way Service**

List No.	Number of Drops One per Outlying Station	*List Price Each
360009	2	\$11.60
360010	4	19.20
360011	6	26.40
360012	8	35.20
360013	10	44.00
360014	12	52.80
360015	15	64.50
360016	20	86.00
360017	24	103.20

\*NOTE: The prices for annunciators do not include hand set. Annunciators of greater capacity can be furnished. Price of any size on request.

#### Hand Set

In addition to the annunciators listed, the following hand set must be used. This is equipped with a three-foot cord, and can be hung on the hook fastened to the side of the annunciator.

Code No.	List Price Each
1003D Black finished hand set . . . . .	\$8.90



**No. 6043J  
Outlying Station with  
Extension Cord**

#### OUTLYING STATIONS

These consist of either a flush or non-flush type apparatus box with black finished hand set and three-foot cord.

## INTER-PHONES

### System No. 16-B (Continued)

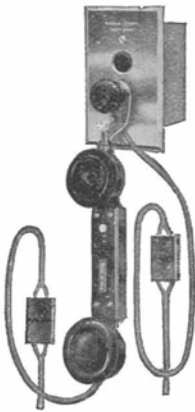

No. 6042T  
Outlying Station  
with Extension Cord

#### OUTLYING STATIONS (Continued)

Code No.	Mounting	Cord	Total Length of Cord	List Price Each
6042R	Flush	Standard	3 ft.	\$15.50
*6042C	Flush	Standard	3 ft.	14.80
6042T	Flush	8 ft. extension	11 ft.	20.20
*6042S	Flush	8 ft. extension	11 ft.	19.50
6043C	Non-flush	Standard	3 ft.	12.00
6043J	Non-flush	8 ft. extension	11 ft.	16.60

\*NOTE: No. 6042C is the same as No. 6042R, but without face plate and wall box. No. 6042S is the same as No. 6042T, but without face plate and wall box. See Note 2 at the bottom of page 243.

#### WIRING AND BATTERY REQUIREMENTS

In case the master station consists of a hand set and wall box, only two wires, common to all stations in the system, will be required. In case the master station consists of a hand set and annunciator, there will be required one wire, common to all stations in the system, and in addition, one individual wire from the master station to each of the outlying stations.

Only one battery is required for the operation of the system. This should consist of three or four Blue Bell dry cells on lines where the distance between the master station and the farthest outlying station is 200 feet or less and No. 22 B.&S. gauge copper wire is used. On lines of greater length it is recommended that instead of increasing the number of dry cells to more than four, larger wires be used as follows:

- 250 to 400 ft., use No. 20 B.&S. gauge copper wire.
- 400 to 600 ft., use No. 18 B.&S. gauge copper wire.
- 600 to 1000 ft., use No. 16 B.&S. gauge copper wire.

Detailed information covering wiring diagrams of system and Inter-phones can be found in our booklet, "Inter-phone Installing Instructions," which will be furnished upon request.

## System No. 16-C

### PROVIDING TWO-WAY SERVICE

#### Master Station Can Call Outlying Stations and vice versa.

In the No. 16-C system the master station consists of a hand set and an annunciator equipped with a bell, a number of drops and a corresponding number of push buttons, one for each outlying station. Associated with these buttons are card holder frames for holding cards to designate the name or station number of each button. The outlying stations may consist of a hand set and apparatus box arranged for either flush or non-flush mounting.

Each outlying station is provided with a push button to ring the bell of the master station annunciator, and at the same time operate one of the annunciator drops.

THIS DIAGRAM IS INTENDED TO SHOW THE RINGING SERVICE PROVIDED BY SYSTEM NO. 16-C AND SHOULD NOT BE CONFUSED WITH THE WIRING DIAGRAM

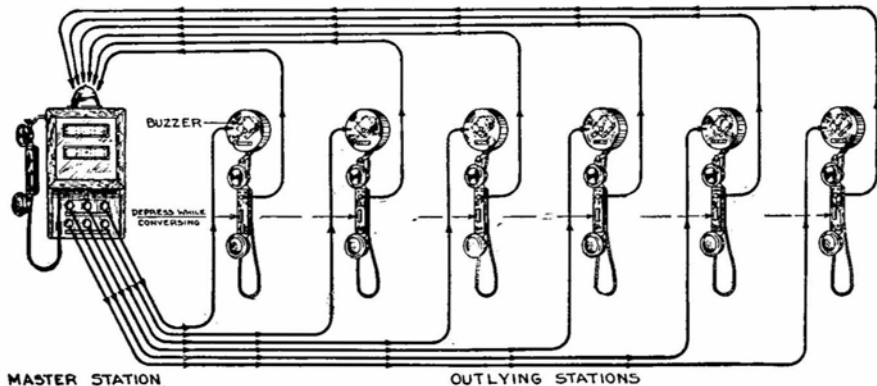

MASTER STATION

OUTLYING STATIONS

## INTER-PHONES System No. 16-C (Continued)

To signal an outlying station from the master station, the annunciator push button corresponding to the station wanted must be depressed, thereby operating the buzzer at the outlying station. No other Inter-phone will be signaled but the one desired.

Conversation can be carried on by depressing the talking bar in the hand set handle.

### EXTENSION CORDS

The standard hand set cord is three feet long. Longer cords are often needed, as in case of illness or for other reasons so that the hand sets can be used in bed or any other point some distance from the apparatus box. In such cases hand sets for outlying stations can be furnished provided for or equipped with an extension cord in addition to the standard three-foot hand set cord. Each extension cord is eight feet long and as many extension cords can be connected as desired.

### MASTER STATION

This consists of a black finished hand set with three-foot cord, and an annunciator with hook for holding the hand set. Annunciator and hand set must be ordered separately. Any one of the following annunciators may be used, depending upon the number of outlying stations for which service is to be provided. The finish of the annunciator is golden oak. Light or dark oak finish can, however, be furnished without additional charge.

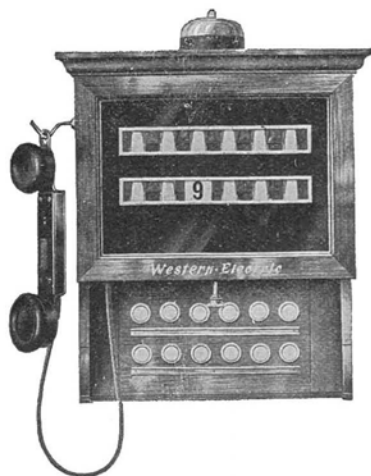

No. 36005  
Master Station Two-way Service

#### Annunciators

List No.	No. of Drops and Push Buttons		*List Price Each
	One per Outlying Station		
360000	2		\$44.00
360001	4		48.00
360002	6		62.00
360003	8		79.00
360004	10		95.00
360005	12		114.00
360006	15		129.00
360007	20		155.10
360008	24		185.50

\*NOTE: Prices for annunciators listed do not include hand set. Annunciators of greater capacities can be furnished. Price of any size on request.

#### Hand Set

In addition to the annunciators listed, the following hand set must be used. This is equipped with a three-foot cord, and can be hung on the hook on the side of the annunciator.

Code No.	List Price
1003D black finished hand set.....	\$8.90

### OUTLYING STATIONS

These consist of either a flush or non-flush type apparatus box with black finished hand set and three-foot cord.



No. 6042M

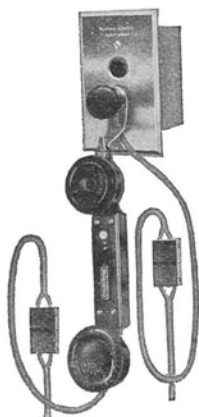

No. 6042P



No. 6043D

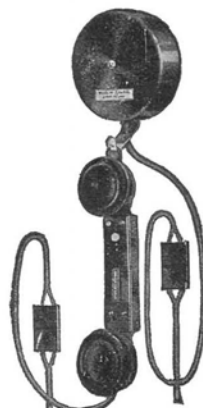

No. 6043H

Types of Outlying Station Hand Set Inter-phones

## INTER-PHONES

### System No. 16-C (Continued)

#### OUTLYING STATIONS (Continued)

Code No.	Mounting	Cord	Total Length of Cord	List Price Each
6042M	Flush	Standard	3 foot	\$17.10
6042D*	Flush	Standard	3 foot	16.40
6042P	Flush	8 foot extension	11 foot	21.80
6042N*	Flush	8 foot extension	11 foot	21.10
6043D	Non-flush	Standard	3 foot	13.80
6043H	Non-flush	8 foot extension	11 foot	18.40

\*NOTE: No. 6042D is the same as No. 6042M, but without face plate and wall box. No. 6042N is the same as No. 6042P, but without face plate and wall box. See note 2 on bottom of page 243.

#### WIRING AND BATTERY REQUIREMENTS

One wire, common to all stations in the system, will be required, and in addition, two individual wires from the master station to each of the outlying stations.

Only one battery is required for the operation of the system. This should consist of three or four Blue Bell dry cells where the distance between the master station and the farthest outlying station is 200 feet or less and No. 22 B.&S. gauge copper wire is used. On lines of greater length it is recommended that instead of increasing the number of dry cells to more than four, larger wires be used as follows:

- 250 to 400 ft. use No. 20 B.&S. gauge copper wire
- 400 to 600 ft. use No. 18 B.&S. gauge copper wire.
- 600 to 1000 ft. use No. 16 B.&S. gauge copper wire.

### Extension Cord



No. 488 Cord

Code No.	Description	List Price Each
488	Black silk-covered, 2 conductor extension cord. Has a plug connection on each end. Used as a part of the No. 1003 Hand Sets. Length 8 feet.....	\$2.60

Detailed information covering wiring diagrams of system and Inter-phones can be found in our booklet "Inter-phone Installing Instructions," which will be furnished upon request.

## INTER-PHONES

### System No. 15

The No. 15 Inter-phone system is a simple and inexpensive system for smaller residences, warehouses, stores or other mercantile establishments, where only a few stations are required and the number of calls between the stations are not frequent.

#### OPERATION

Each station is equipped with one push button for signaling the other Inter-phones in the system. Whenever the push button at any one station is depressed THE BELLS AT ALL THE OTHER STATIONS WILL RING SIMULTANEOUSLY.

When there are more than two stations in the system, it becomes necessary to provide some means whereby IT IS POSSIBLE TO INDICATE TO THE VARIOUS STATIONS WHICH ONE OF THEM IS WANTED TO RESPOND TO THE RING OF THE BELL. This can be arranged BY A CODE OF SIGNALS made up of various numbers of rings; for instance: One ring for station No. 1, two rings for station No. 2, three rings for station No. 3, etc. Thus a certain number of rings originated at any one of the stations will indicate the station desired, and none of the others, to whom the signal will also be audible, will respond.

If more than six stations are in service, the signaling code becomes cumbersome and mistakes are likely to occur, due to the possibility of misunderstood signals.

**Only one conversation can be carried on at a time.**

This system requires one "Battery Station," which should be located near the battery. The other Inter-phones in the system should be of the "Non-Battery Station" type. In a system consisting of five stations, for example, there should be one battery station and four non-battery stations.

**THIS DIAGRAM IS INTENDED TO SHOW THE RINGING SERVICE PROVIDED BY SYSTEM NO.15 AND SHOULD NOT BE CONFUSED WITH THE WIRING DIAGRAM.**

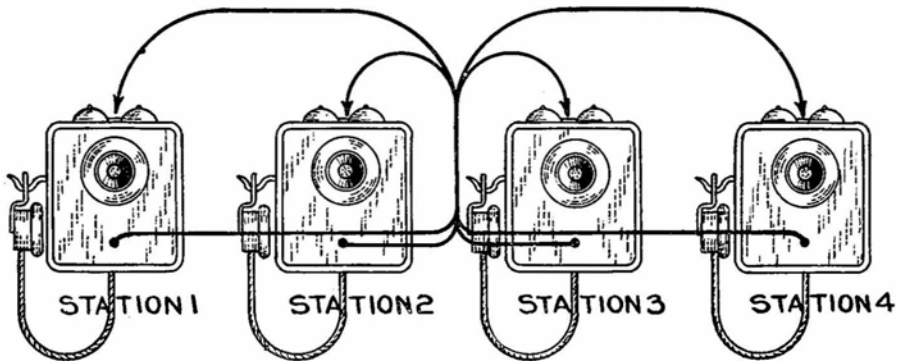

The class of service described is known as "code ringing and common talking."

#### CAPACITY

Two to six stations are recommended for this system. More stations can be added, though at the expense of ease and certainty in signaling.

#### TYPES OF INSTRUMENTS

WALL, DESK and HAND SET Inter-phones can be used interchangeably in the same system.

#### Wall Type Inter-phones

Wooden case with golden oak finish and nickel trimmings.



No. 1327 Type Wall Inter-phone

Code No.	Mounting	Used for	List Price
			Each
1327S	Non-flush	Battery Station	\$12.00
1327T	Non-flush	Non-battery station	11.20

Size of cabinet 5¾ inches wide, 6⅞ inches long, 3¼ inches deep.

## INTER-PHONES

### System No. 15 (Continued)

### Wall Type Inter-phones

**Metal case with brush brass finished face plate and metal wall box.**

Code No.	Mounting	Used for	List Price Each
1339L	*Flush	Battery Station	\$16.50
1339M	*Flush	Non-battery station	14.70

Size of face plate  $5\frac{1}{16}$  inches wide,  $8\frac{1}{16}$  inches long.

\*Metal wall box furnished.

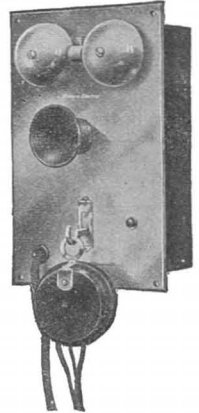

**No. 1339 Type Wall Inter-phone**

### Desk Type Inter-phones

**Desk stand black finish, with push button in stem of stand and buzzer in the base. Terminal block and six foot cord are included.**

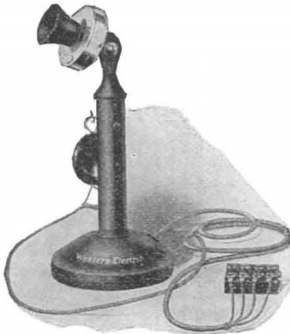

**No. 6034 Type Desk Inter-phone**

Code No.	Used for	List Price Each
6034AS	Battery station	\$27.00
6034AR	Non-battery station	25.60

### Hand Set Inter-phones

This presents one of the most convenient types of talking equipment. The transmitter and receiver are a part of the hand set which can be held and operated with one hand, leaving the other free. A bar marked "Press to Talk" is mounted in the handle and is held down by the natural position of the hand while talking. When not in use, the hand set can be hung on a hook or laid down in any position. The hand set is finished in black.

In connection with the hand sets it is necessary to use apparatus boxes containing connecting terminals and other accessories. Two types of apparatus boxes can be furnished:

1. Round boxes arranged for non-flush mounting with black finished metal cover and nickel hook. Approximate size of box,  $3\frac{1}{8}$  inches diameter,  $1\frac{5}{8}$  inches deep.
2. Metal boxes arranged for flush mounting, intended to be set in the wall and equipped with brush brass finished face plate. See note 2 at the bottom of page 243.



**No. 6042 Type Hand Set Inter-phone**

Code No.	Mounting	Used for	List Price Each
6042H	Flush	Battery station	\$16.20
*6042A	Flush	Battery station	15.50
6042J	Flush	Non-battery station	14.90
†6042B	Flush	Non-battery station	14.20
6043A	Non-flush	Battery station	16.90
6043B	Non-flush	Non-battery station	15.70

\*No. 6042A is the same as No. 6042H, but without face plate and wall box. See note 2 at the bottom of page 243.

†No. 6042B is the same as No. 6042J, but without face plate and wall box. See note 2 at the bottom of page 243.

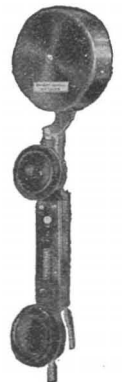

**No. 6043 Type Hand Set Inter-phone**

**INTER-PHONES**

**System No. 15' (Continued)**

**Wiring and Battery Requirements**

Three wires are required for connecting the Inter-phones and battery when only two stations are to be used. When there are three or more stations, four wires are necessary throughout the system.

Five Blue Bell dry cells are required for the operation when the length of the line is 750 feet or less, and not more than four stations are to be used, connected by No. 20 or No. 22 B.&S. gauge copper wire. If more than four Inter-phones are required and the line is longer than 750 feet, larger wires should be used. This should be determined by the installer in accordance with the information furnished in our booklet, "Inter-phone Installing Instructions." The Blue Bell dry cells can be placed in the basement or any other accessible place.

Blue Bell dry cells are listed on page 17.

Detailed information covering wiring diagrams of system and Inter-phones, wiring requirements, installing instructions, etc., can be found in our booklet, "Inter-phone Installing Instructions," which will be furnished upon request.

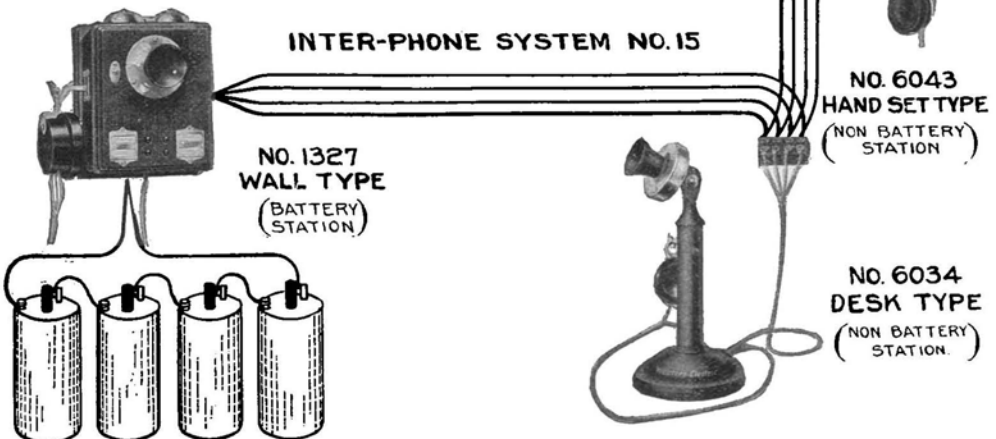

## INTER-PHONES System No. 14

The No. 14 Inter-phone System is intended for use where only two stations will be required, and located a considerable distance apart. A feature of this system is that only two wires are required to connect the Inter-phones.

### OPERATION

**Either station can ring and talk to the other.**

This is done by depressing the push button with which each set is equipped, thereby ringing the bell at the other station, holding the receiver to the ear and talking into the transmitter.

### TYPES OF INSTRUMENTS

Wall and desk Inter-phones can be used interchangeably in this system.



No. 1327 Type  
Wall Inter-phone

### Wall Type Inter-phone

**Wall case with golden oak finish and nickel trimmings.**

Code No.	Mounting	List Price Each
1327.AA	Non-flush	\$11.60
Size of cabinet 5 $\frac{3}{4}$ inches wide, 6 $\frac{7}{8}$ inches long, 3 $\frac{1}{4}$ inches deep.		

### Desk Type Inter-phone

**Desk stand—black finish. Signaling equipment, consisting of bell and push button, is contained in a separate wall box, having a golden oak finish. Cord between desk stand and box is six feet long.**

Code No.  
6015J

Mounting  
Non-flush wall box

List Price Each  
\$25.50

Wall box cabinet 5 $\frac{3}{8}$  inches wide, 6 $\frac{1}{8}$  inches long, 3 $\frac{3}{4}$  inches deep.



No. 6015 Type  
Desk Inter-phone

### Wiring and Battery Requirements

Two Blue Bell dry cells are required at each station to furnish talking current.

For furnishing signaling current, the following additional dry cells are required at each station:

Length of Line Not Exceeding	B. & S. Gauge Copper Wire			
	No. 12	No. 14	No. 16	No. 18
	—Additional Number of Cells for Each Station—			
750 ft.	1	1	1	1
1000 ft.	1	1	1	2
1500 ft.	1	1	1	3
2000 ft.	1	1	2	
2500 ft.	1	2	3	
3000 ft.	1	2		
4000 ft.	2	3		
5000 ft.	2			
6000 ft.	3			

Blue Bell dry cells are listed on page 17.

Detailed information covering wiring diagrams of system and instruments, installing instructions, etc., can be found in our booklet, "Inter-phone Installing Instructions," which will be furnished upon request.

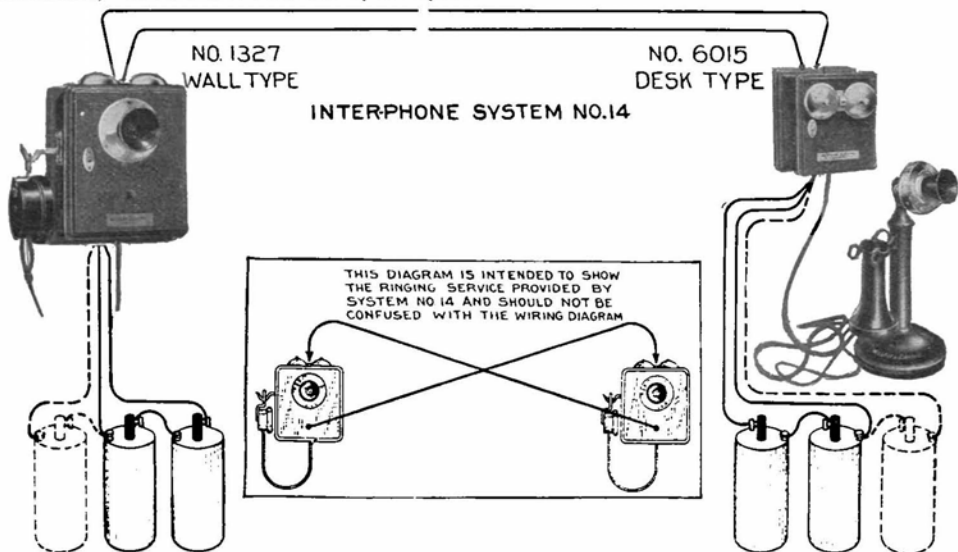

## INTER-PHONES

### Systems for Apartment Houses

#### Introductory

Apartment house Inter-phones are for use in place of the old-time speaking tube for effecting communication between the vestibule, apartments, janitor and tradesmen.

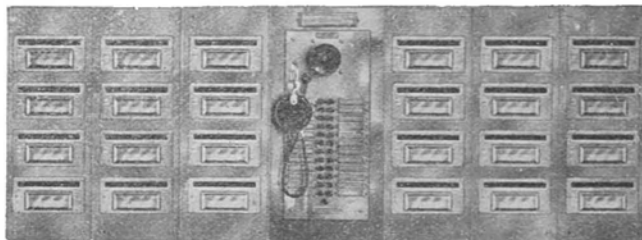

No. 1362 Vestibule Inter-phone with Letter Boxes

Speaking tubes, besides being antiquated, are unsanitary and do not have the flexibility that an intercommunicating system should have to give the best service. Messages spoken through speaking tubes are for the most part not understandable. Inter-phones, on the other hand, have everything to recommend them. Some of the most important considerations in their favor follow:

1. The apartment house Inter-phone system does all the speaking tube should do, and, in addition, is absolutely sanitary. It is perfectly flexible, permitting of additions with a minimum of labor and inconvenience.

2. The apartment house Inter-phone system eliminates the hall boy. It is always ready for service. Its upkeep is insignificant when compared to a hall boy's wages.

3. The Inter-phones in vestibules and apartments are attractive in design and substantially built.

4. The cost of installation is very much less than that for a speaking tube of similar comprehensiveness.

5. A diagram is supplied with each Inter-phone showing the interior wiring. In addition a large diagram is furnished with each vestibule and janitor's Inter-phone showing the wiring of the complete system. All terminals are plainly marked.

The following Apartment House Inter-phone Systems may be divided primarily into two classes, in accordance with the service they will furnish:

1. **Systems Nos. 7, 8, 9 and 10 will furnish selective ringing and selective talking or non-interfering service, making it possible for a number of conversations to take place simultaneously.**

2. **System No. 20 will furnish selective ringing and common talking service, making possible only one conversation at one time.**

### Systems Nos. 7, 8, 9 and 10

These systems are planned throughout with the utmost care to insure satisfaction under all service conditions. The telephone instruments themselves are neat and attractive in design. Systems Nos. 7, 8, 9 and 10 differ from one another in the variety of points in the apartment house that can be connected for intercommunicating service. They are, however, so arranged that one system may be expanded into another by merely supplying additional apparatus.

#### OPERATION

The systems may consist of one, two, three or more central or master Inter-phones located in the vestibule, janitor's or tradesmen's entrance. These sets may be connected to (from 3 to 24) Inter-phones located in the apartments.

## INTER-PHONES

### Systems for Apartment Houses (Continued)

#### Systems Nos. 7, 8, 9 and 10 (Continued)

#### OPERATION (Continued)

The vestibule, janitor's and tradesmen's Inter-phones are equipped with a number of push button keys, one for each apartment station. Associated with these push button keys are card holder frames to hold cards designating the name or apartment number of the buttons. BY SIMPLY DEPRESSING THE BUTTON MARKED WITH THE NAME OR THE NUMBER OF THE APARTMENT DESIRED, THE BELL OF THE INTER-PHONE INSTALLED IN THAT APARTMENT WILL BE RUNG. NO OTHER STATION IN THE SYSTEM WILL BE SIGNALLED BUT THE ONE DESIRED.

The suite Inter-phones can be provided with one or two buttons which, when depressed, will ring the janitor's station or operate an electric door opener.

**SEPARATE CONVERSATIONS MAY TAKE PLACE SIMULTANEOUSLY BETWEEN EACH OF THE VESTIBULE, JANITOR'S AND TRADESMEN'S SETS, AND THREE DIFFERENT APARTMENTS.** This is manifestly impossible with a single speaking tube system.

#### TYPES OF INSTRUMENTS

Wall or hand set type Inter-phones may be used interchangeably in the same system for suite service. The vestibule, janitor's and tradesmen's Inter-phones are of the wall type only. Detailed description of these instruments is given in the following pages.

### System No. 7

#### SERVICE

Vestibule can call apartments. Apartments can open door, if desired.

#### CAPACITY

One vestibule Inter-phone and any number of suite Inter-phones up to 24.

#### APPARATUS REQUIRED FOR SYSTEM NO. 7

	See Page
1 No. 1362 type vestibule Inter-phone .....	260
Letter boxes as required .....	260
Suite Inter-phones as required of any of the following types:	
No. 1327AB non-flush, wooden wall Inter-phone, or .....	260
No. 1339R flush, metal wall Inter-phone, or .....	261
No. 6042L flush apparatus box and hand set, or .....	261
No. 6043G non-flush apparatus box and hand set .....	261
1 No. 295BC coil and condenser box .....	264

#### WIRING AND BATTERY REQUIREMENTS

1 wire common to entire system	}	264
1 individual wire for each Inter-phone in system		
1 additional individual wire for vestibule Inter-phone		
*1 wire common to entire system (for door opener)		
1 door opener		
Battery to furnish current for talking, ringing and operating door opener		
Miscellaneous installing material		

\*NOTE: This common wire can be omitted in case door opener is not required.

### System No. 8

#### SERVICE

Vestibule can call apartments and janitor.  
 Apartments can call janitor and open door, if desired  
 Janitor can call apartments.

#### CAPACITY

One vestibule Inter-phone, one janitor's Inter-phone and any number of suite Inter-phones up to 24.

INTER-PHONES

Systems for Apartment Houses (Continued)

System No. 8 (Continued)

APPARATUS REQUIRED FOR SYSTEM No. 8

See Page

1 No. 1362 type vestibule Inter-phone.....	260
Letter boxes as required.....	260
Suite Inter-phones, as required, of any of the following types:	
No. 1327N non-flush, wooden wall Inter-phone, or.....	260
No. 1339A flush, metal wall Inter-phone, or.....	261
No. 6042W flush apparatus box and hand set, or.....	261
No. 6043G non-flush apparatus box and hand set with separate push button.....	261
1 No. 1350 type janitor's Inter-phone.....	262
1 janitor's annunciator.....	262
1 No. 295AS coil and condenser box.....	264

WIRING AND BATTERY REQUIREMENTS

1 wire common to entire system	}	264
2 individual wires for each Inter-phone in system		
*1 wire common to entire system (for door opener)		
1 door opener		
Battery to furnish current for talking, ringing and operating door opener		
Miscellaneous installing material		
*NOTE: This common wire can be omitted if door opener is not required.		

System No. 9

SERVICE

- Vestibule can call apartments and janitor.
- Apartments can call janitor and open door, if desired.
- Janitor and tradesmen can call apartments.

CAPACITY

One vestibule Inter-phone, one janitor's Inter-phone, one tradesmen's Inter-phone and any number of suite Inter-phones up to 24.

APPARATUS REQUIRED FOR SYSTEM No. 9

See Page

1 No. 1362 type vestibule Inter-phone.....	260
Letter boxes as required.....	260
Suite Inter-phones, as required, of any of the following types:	
No. 1327N non-flush, wooden wall Inter-phone, or.....	260
No. 1339A flush, metal wall Inter-phone, or.....	261
No. 6042W flush apparatus box and hand set, or.....	261
No. 6043G non-flush apparatus box and hand set with separate push button.....	261
1 No. 1350 type janitor's Inter-phone.....	262
1 janitor's annunciator.....	262
1 No. 1350 type tradesmen's Inter-phone.....	263
1 No. 295BD coil and condenser box.....	264

WIRING AND BATTERY REQUIREMENTS

1 wire common to entire system	}	264
2 individual wires for each Inter-phone in the system		
*1 wire common to entire system (for door opener)		
1 door opener.....		
Battery to furnish current for talking, ringing and operating door opener		
Miscellaneous installing material.....		
*NOTE: This common wire can be omitted if door opener is not required.		

## INTER-PHONES

### Systems for Apartment Houses (Continued)

#### System No. 10

##### SERVICE

This system provides the same service as outlined under System No. 9, but on a larger scale. It is intended for use where several vestibules in the same or adjoining apartment houses are to be served by one janitor. In this case, the janitor's equipment consists of a switchboard which combines the functions of a wall type Inter-phone and annunciator.

##### CAPACITY

One janitor's switchboard, two or more vestibule and tradesmen's Inter-phones and any number of suite Inter-phones up to 70.

#### APPARATUS REQUIRED FOR SYSTEM NO. 10

See Page

2 or more No. 1362 type vestibule Inter-phones . . . . .	260
Letter boxes as required . . . . .	260
Suite Inter-phones, as required, of any of the following types:	
No. 1327N non-flush, wooden wall Inter-phone, or . . . . .	260
No. 1339A flush, metal wall Inter-phone, or . . . . .	261
No. 6042W flush, apparatus box and hand set, or . . . . .	261
No. 6043G non-flush apparatus box and hand set, with separate push button . . . . .	261
1 janitor's annunciator switchboard . . . . .	262
2 or more No. 1350 type tradesmen's Inter-phones . . . . .	263
1 or more No. 295 coil and condenser boxes . . . . .	264

#### WIRING AND BATTERY REQUIREMENTS

1 wire common to entire system	}	. . . . . 264
2 individual wires for each Inter-phone in the system		
1 additional individual wire for each vestibule Inter-phone		
*1 wire common to entire system (for door opener)		
1 door opener		
Battery to furnish current for talking, ringing and operating door opener		
Miscellaneous installing material		

†NOTE: For the janitor's annunciator switchboard and each vestibule and tradesmen's Inter-phone, one retardation coil and one condenser will be required.

\*NOTE: This common wire can be omitted if door opener is not required.

### Vestibule Equipment for Systems Nos. 7, 8, 9 and 10

This consists of a vestibule Inter-phone and any number of letter boxes.

#### VESTIBULE INTER-PHONES

Metal case with brush brass finish, arranged for flush mounting. The standard instruments are furnished with 7, 13, 17, 21 and 25 button keys, each one representing one apartment, except the last or odd button, which represents the janitor. The construction of the push button keys insures long life and positive operation. The function of each of these keys, when operated, is to establish connections between the vestibule and suite Inter-phones. When pressed all the way down, contacts are established for the ringing circuit, with the result that the station, associated with the operated push button key, will be signaled. When the pressure is released, the key assumes an intermediate position, thereby breaking the ringing contact and connecting the called line for conversation. The key is automatically held in this intermediate position by a locking plate. The operation of another button releases the key and restores it to its normal position.

INTER-PHONES

Systems for Apartment Houses (Continued)

Vestibule Equipment (Continued)

VESTIBULE INTER-PHONES (Continued)

Talking current is cut off when the receiver is hung back on its hook. The last or odd button (for calling the janitor) is non-locking in the operating position. This provides a means for releasing the other buttons in the set should someone maliciously operate all of them at one time.

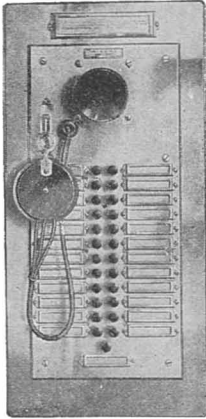

No. 1362 Type Vestibule Inter-phone

Code No.	Capacity	List Price Each
1362G	7 buttons	\$49.00
1362H	13 buttons	55.00

Size of face plate, 7 $\frac{3}{8}$  inches wide, 11 $\frac{3}{8}$  inches long.

1362D	17 buttons	\$60.00
1362E	21 buttons	65.90
1362F	25 buttons	71.70

Size of face plate, 7 $\frac{3}{8}$  inches wide, 16 $\frac{1}{8}$  inches long.

VESTIBULE LETTER BOXES

Metal brush brass finished boxes to match the vestibule Inter-phone. They are equipped with two or four separate compartments and are suitable for mounting on either side of the vestibule Inter-phone.

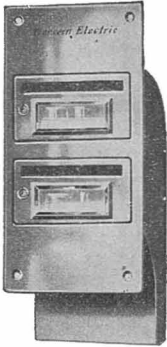

No. 12013 Letter Box

List No.	Capacity	To Mount With	List Price Each
12013	2 compartments	7 and 13 button Inter-phones	\$13.50
116937	4 compartments	17, 21 and 25 button Inter-phones	27.20

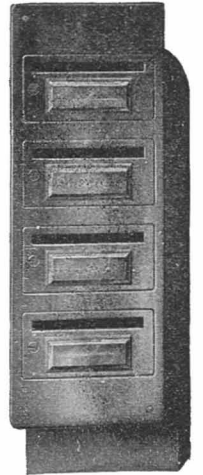

No. 116937 Letter Box

Suite Inter-phones for Systems Nos. 7, 8, 9 and 10

SUITE WALL TYPE

Wooden case with golden oak finish and nickel trimmings.



No. 1327 Type Wall Inter-phone

Code No.	Mounting	Capacity	List Price Each
1327N	Non-flush	2 buttons (marked "Jan." and "Door")	\$11.60
1327AB	Non-flush	1 button (unmarked)	10.50

Size of cabinet 5 $\frac{3}{4}$  inches wide, 6 $\frac{1}{8}$  inches long, 3 $\frac{1}{4}$  inches deep.

## INTER-PHONES

## Systems for Apartment Houses (Continued)

## Suite Inter-phones (Continued)

## SUITE WALL TYPE (Continued)



No. 1339 Type  
Wall Inter-telephone

Metal case with brush brass finished face plate and metal outlet box.

Code No.	Mounting	Capacity	List Price Each
1339A	*Flush	2 buttons (marked "Jan." and "Door")	\$14.40
1339R	*Flush	1 button (unmarked)	13.20

Size of face plate, 5  $\frac{1}{8}$  inches wide, 8  $\frac{1}{8}$  inches long.

\*Metal wall box furnished.

## SUITE HAND SET

This presents one of the most convenient types of talking equipment. The transmitter and receiver are a part of the hand set which is held and operated with one hand, leaving the other free. A bar marked "Press to Talk" is mounted in the hand set handle and is held down by the natural position of the hand while conversing. When not in use, the hand set can be hung on a hook or laid down in any position. The hand set is finished in black.

In connection with the hand set it is necessary to use apparatus boxes containing connecting terminals, etc. Two types of apparatus boxes can be furnished:

1. Round boxes arranged for non-flush mounting with black finished metal cover and nickel plated hook. Approximate size, 3  $\frac{1}{16}$  inches diameter by 1  $\frac{5}{16}$  inches deep.
2. Metal boxes arranged for flush mounting, intended to be set in the wall, and equipped with a brush brass finished face plate. See note 2 at the bottom of page 243.



No. 6042 Type  
Hand Set  
Inter-telephone

Code No.	Mounting	Capacity	List Price Each
6042L	Flush	1 ringing button	\$15.10
*6042G	Flush	1 ringing button	14.40
6042W	Flush	2 ringing buttons	16.50
†6042U	Flush	2 ringing buttons	15.80
6043G	Non-flush	1 ringing button	15.60

Separate push button List No. 360799 required for non-flush type if two ringing buttons are desired.

\*6042G is same as 6042L, but without face plate and wall box. See note 2 at the bottom of page 243.

†6042U is same as 6042W, but without face plate and wall box. See note 2 at the bottom of page 243.



No. 6043 Type  
Hand Set  
Inter-telephone

## INTER-PHONES

### Systems for Apartment Houses (Continued)

#### Janitor's Equipment

If the janitor has but one vestibule to serve, a wall type Inter-phone with a separate annunciator should be used. The latter gives a visible indication of the station calling. If the janitor has to serve more than one vestibule (as in System No. 10) the janitor's equipment should consist of a janitor's annunciator, which apparatus combines the features of the wall type Inter-phone and annunciator.



**No. 1350 Type  
Janitor's Inter-phone**

#### WALL TYPE INTER-PHONES FOR SYSTEMS NO. 8 AND 9

Non-flush wooden case with golden oak finish, and nickel and black trimmings. No ringer is provided as bell is furnished with the annunciator. These Inter-phones are made in standard capacities of 7, 13 and 25 push button keys, the construction and operation of which are the same as outlined under Vestibule Inter-phones. The last or odd button in each Inter-phone is non-locking in operation and provides connection with the vestibule Inter-phone.

Code No.	Capacity	List Price Each
1350A	7 buttons	\$28.50
1350E	13 buttons	33.50

Size of cabinet, 6 $\frac{5}{8}$  inches wide, 10 inches long, 4 inches deep.

1350G	25 buttons	\$43.40
-------	------------	---------

Size of cabinet, 7 $\frac{5}{8}$  inches wide, 13 $\frac{1}{4}$  inches long, 4 inches deep.

#### ANNUNCIATORS FOR SYSTEMS NO. 8 AND 9

Wooden case with oak finish. Other finishes can be furnished at slight increase in price.



**Janitor's Annunciator**

Code No.	Drop Capacity	Drop Arrangement	List Price Each
361332	4	1 horizontal row	\$10.60
361333	6	2 horizontal rows	14.00
361334	8	2 horizontal rows	18.70
361335	10	2 horizontal rows	22.00
361336	12	2 horizontal rows	26.00
361337	15	3 horizontal rows	32.00
361338	18	3 horizontal rows	39.70
361339	25	5 horizontal rows	53.00

#### ANNUNCIATOR FOR SYSTEM NO. 10

Wooden case with oak finish. Number of vestibule drops must be specified on order. Prices do not include talking equipment, which must be ordered separately.

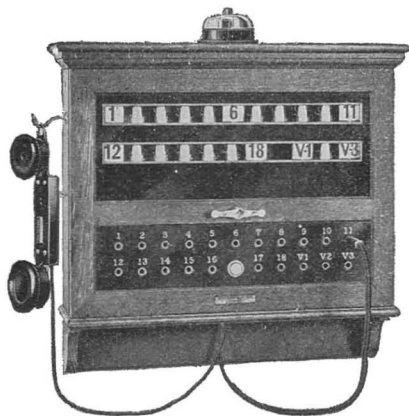

**Janitor's Annunciator Switchboard**

Code No.	Drop Capacity	Drop Arrangement	List Price Each
1040	10	2 horizontal rows	\$92.00
1041	14	2 horizontal rows	123.00
1042	18	2 horizontal rows	141.00
1043	20	2 horizontal rows	152.00
1044	24	2 horizontal rows	182.50
1045	30	3 horizontal rows	213.90
1046	36	3 horizontal rows	256.60
1047	42	3 horizontal rows	299.40
1048	48	4 horizontal rows	342.00
1049	56	4 horizontal rows	385.80
1050	60	5 horizontal rows	413.40
1051	70	5 horizontal rows	482.30

## INTER-PHONES

## Systems for Apartment Houses (Continued)

## Janitor's Equipment (Continued)

## TALKING EQUIPMENT FOR JANITOR'S TELEPHONE SWITCHBOARD



No. 1320BF Desk Stand



No. 1003K Hand Set

Code No.		List Price Each
1003K	Hand set, black finish, 3 ft. cord.....	\$8.80
1320BF	Desk stand, black finish, 6 ft. cord.....	16.50

## Tradesmen's Inter-phones for Systems Nos. 9 and 10

No. 1350 Type  
Tradesmen's Inter-telephone

Non-flush wooden case finished in golden oak with nickel and black trimmings. No bell is provided as apartments will not need to call this station. The sets are furnished in standard capacities of 7, 13 and 25 push button keys, the construction and operation of which is the same as outlined under vestibule Inter-phones.

Code No.	Capacity	List Price Each
1350A	7 buttons	\$28.50
1350E	13 buttons	33.50

Size of cabinet,  $6\frac{3}{8}$  inches wide, 10 inches long, 4 inches deep.

1350G	25 buttons	\$43.40
-------	------------	---------

Size of cabinet,  $7\frac{5}{8}$  inches wide,  $13\frac{1}{4}$  inches long, 4 inches deep.

## Accessories

## COIL AND CONDENSER BOX

Non-flush wooden wall box finished in golden oak. One retardation coil and one condenser are required for each vestibule, janitor's (either wall Inter-telephone or switchboard) or tradesmen's station. This apparatus is necessary in order that separate conversations may be carried on simultaneously between vestibule, janitor's and tradesmen's Inter-telephones—and three apartments without having the conversations interfere with each other. The condenser provides a path for the high frequency talking currents, which cannot pass through the high impedance retardation coil.

## INTER-PHONES

### Systems for Apartment Houses (Continued)

#### Accessories (Continued)

#### COIL AND CONDENSER BOX (Continued)

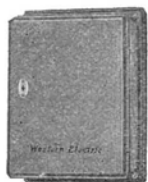

**Coil and Condenser  
Box**

Code No.	Containing	For System No.	List Price Each
295BC	1 coil and 1 condenser	7	\$6.80
295AS	2 coils and 2 condensers	8	10.20
295BD	3 coils and 3 condensers	9 and 10	13.70

#### CABLE

For connecting the various stations of a system, either cable or loose wires can be used, depending largely upon the layout of the building. Where there is a long run of a large number of wires (for instance, between the janitor, vestibule, and tradesmen Inter-phones or for the vertical riser from floor to floor) it will be found economical to use cable, and to install cable terminals or connecting blocks at all of the distributing and junction points.

For connecting the Inter-phones of the various apartments to these distributing points, loose wires (No. 22 B.&S. gauge) can be used. The number of wires needed for systems Nos. 7, 8, 9 and 10 is outlined on the preceding pages. This data should be used when selecting the cable, a complete list of which can be found on page 52.

#### CABLE TERMINALS

Cable terminals or connecting blocks should be used at all junction points of cable and at the distributing points where the cable conductors are distributed to the various apartment stations by means of loose wires. Where there are large numbers of wires to be connected, cable terminals are most suitable. For a small number of wires, connecting blocks will be satisfactory.

Cable terminals are listed on page 55.

Connecting blocks are listed on page 58.

#### BATTERIES

Not more than 12 Blue Bell dry cells will be necessary for operating any of the above systems (5 cells for the talking circuits and 4 to 7 cells for the ringing circuits, depending upon the length of the line). The cells can be placed in the basement or any other accessible place.

Blue Bell dry cells are listed on page 17.

**NOTE:** This battery data is based on the use of standard Inter-phone cable or No. 22 B.&S. gauge wire.

#### DOOR OPENER

If a door opener is included in the system, additional dry cells will be required, the number of which depends upon the working of the opener and the adjustment of the door. Generally, two or three cells have been found sufficient for this purpose.

Any standard type of door opener may be used.

Detailed information covering wiring diagrams of systems and Inter-phones, etc., can be found in our booklet, "Inter-phone Installing Instructions," which will be furnished upon request.

# INTER-PHONES

Systems for Apartment Houses (Continued)

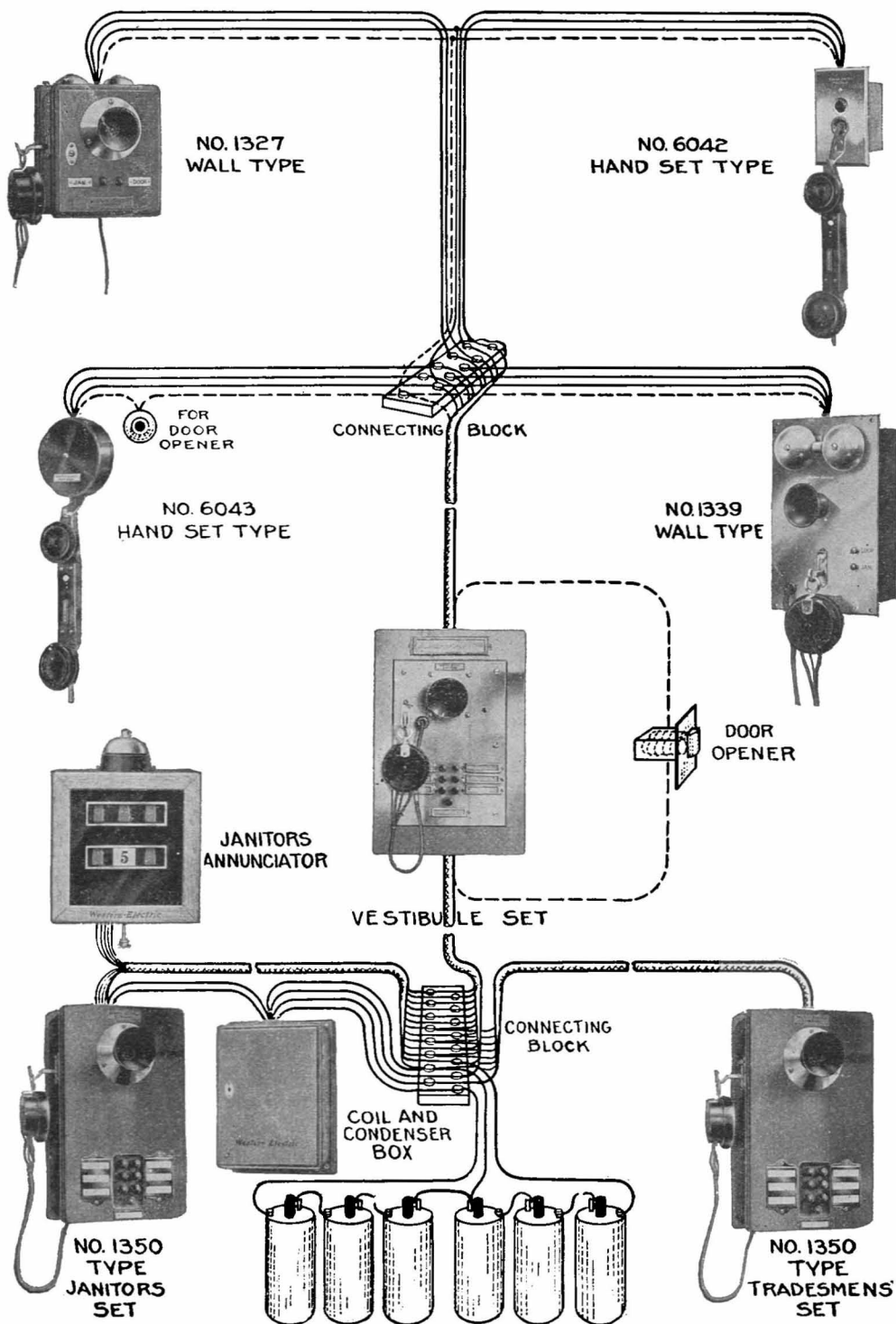

INTER-PHONE SYSTEM NO. 9

## INTER-PHONES

### Systems for Apartment Houses (Continued)

#### System No. 20

The No. 20 Inter-phone system has been designed to provide an inexpensive and reliable means of communication between vestibule, apartments, janitor's quarters, laundry and tradesmen's entrance. There are eight different combinations of the No. 20 system, differing from each other in the variety of points in the apartment house that can be connected for intercommunicating service. The operation of each of these combinations, however, is the same.

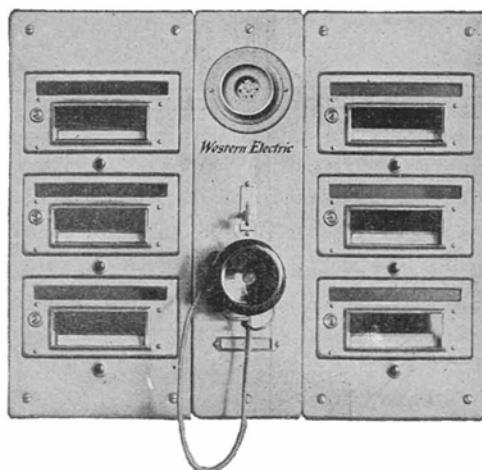

**Vestibule Equipment for Six Apartments**

#### OPERATION

The vestibule equipment consists of one vestibule Inter-phone and any number of letter boxes.

The vestibule Inter-phone is provided with necessary talking equipment and one push button, the latter to be used for calling the janitor. Each letter box is provided with three compartments. A push button is mounted below each compartment. When depressed this button will ring the bell of the Inter-phone in the apartment with which the letter box compartment is associated. No other Inter-phone in the system will be signaled but the one selected. Each letter box compartment is also equipped with a card holder for indicating the name or apartment number.

The suite sets can be provided with a number of push buttons, depending upon the combination selected. These push buttons when depressed will operate the door opener, call the janitor, laundry or any other combination desired.

The janitor's, laundry and tradesmen's Inter-phones can be arranged either for receiving calls from the other stations without being able to signal back, or for receiving calls and for signaling back to any one of the suite sets. In the latter case a separate push button block must be used. This can be mounted conveniently beside the instrument.

**Only One Conversation Can Be Carried on at a Time Over This System.**

The class of service as described under this system is known as "selective ringing and common talking."

**INTER-PHONES**

**Systems for Apartment Houses (Continued)**

**System No. 20 (Continued)**

There are eight combinations of the No. 20 System available. The diagram associated with each SERVICE description is intended to show the service provided and should not be confused with the wiring diagram.

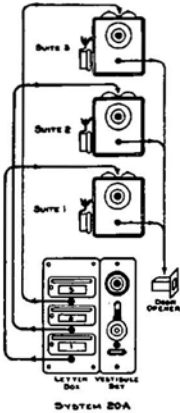

**System No. 20-A**

**SERVICE**

Vestibule can call apartments, apartments can open door.

**APPARATUS REQUIRED**

1 No. 1520U vestibule Inter-telephone.....	See Page	
1 or more No. 3 letter boxes.....	269	
3 or more suite Inter-telephones	} .....	
No. 1327U non-flush, wood type or		269
No. 1339H flush, metal type		

**WIRING AND BATTERIES REQUIRED**

*3 wires common to all Inter-phones and battery.....	270
1 wire for each suite Inter-telephone.....	270
Batteries to furnish current for talking, ringing and operating door opener.....	270
1 door opener.....	270
Miscellaneous installing material.....	270

\*One common wire can be omitted if door opener is not required.

**System No. 20-B**

**SERVICE**

Vestibule can call apartments, apartments can open door and call janitor.

**APPARATUS REQUIRED**

1 No. 1520U vestibule Inter-telephone.....	See Page	
1 or more No. 3 letter boxes.....	269	
3 or more suite Inter-telephones	} .....	
No. 1327NM non-flush, wood type or		269
No. 1339AM flush, metal type		
1 No. 1327T janitor or laundry Inter-telephone.....	270	

**WIRING AND BATTERIES REQUIRED**

*4 wires common to all Inter-phones.....	270
1 wire for each suite Inter-telephone, and	
3 extra wires for connecting battery with vestibule and janitor or laundry Inter-phones.....	270
Batteries to furnish current for talking, ringing and operating door opener.....	270
1 door opener.....	270
Miscellaneous installing material.....	270

\*One common wire can be omitted if door opener is not required.

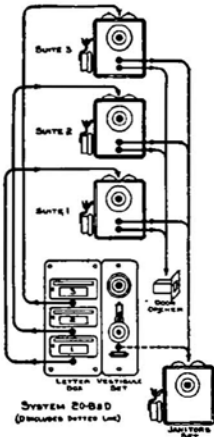

**System No. 20-C**

**SERVICE**

Vestibule can call apartments and janitor, apartments can open door.

**APPARATUS REQUIRED**

Same as System No. 20-A with addition of 1 No. 1327T janitor's Inter-telephone.

**WIRING AND BATTERIES REQUIRED**

*3 wires common to all Inter-phones.....	See Page
1 wire for each suite Inter-telephone and	270
4 extra wires for connecting battery with vestibule and janitor's Inter-telephone.....	270
Batteries to furnish current for talking, ringing and operating door opener.....	270
1 door opener.....	270
Miscellaneous installing material.....	270

\*One common wire can be omitted if door opener is not required.

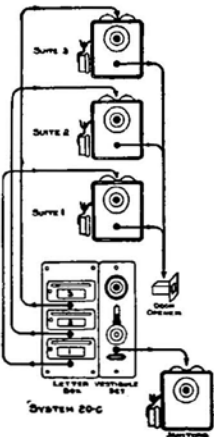

**System No. 20-D**

**SERVICE**

Vestibule can call apartments and janitor, apartments can open door and call janitor.

**APPARATUS, WIRING AND BATTERIES REQUIRED**

Same as System No. 20-B.

## INTER-PHONES

### Systems for Apartment Houses (Continued)

#### System No. 20 (Continued)

##### System No. 20-E

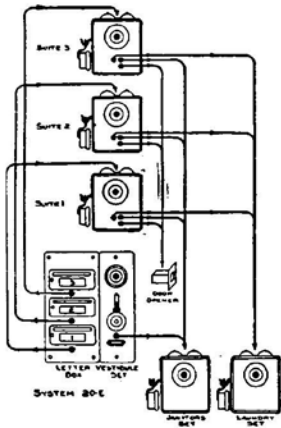

**SERVICE**

Vestibule can call apartments and janitor, apartments can open door and call janitor and laundry.

**APPARATUS REQUIRED**

	See Page
1 No. 1520U vestibule Inter-phone .....	269
1 or more No. 3 letter boxes .....	269
3 or more suite Inter-phones	
No. 1327K non-flush, wood type or	} 269
No. 1339C flush, metal type	
1 No. 1327T janitor's Inter-phone .....	270
1 No. 1327T laundry Inter-phone .....	270

**WIRING AND BATTERIES REQUIRED**

*5 wires common to all Inter-phones .....	270
1 wire for each suite Inter-phone and	
3 extra wires for connecting battery, vestibule, janitor's and laundry Inter-phones .....	270
Batteries to furnish current for talking, ringing and operating door opener, 1 door opener, miscellaneous installing material ..	270
*One common wire can be omitted if door opener is not required.	

##### System No. 20-F

**SERVICE**

Vestibule can call apartments, apartments can open door and call janitor or laundry, and laundry or janitor can call apartments.

**APPARATUS REQUIRED**

	See Page
1 No. 1520U vestibule Inter-phone .....	269
1 or more No. 3 letter boxes .....	269
3 or more suite Inter-phones .....	
No. 1327NM non-flush, wood type or	} 269
No. 1339AM flush, metal type	
1 No. 1327T janitor's or laundry Inter-phone .....	270
1 push button block (one button for each suite Inter-phone) .....	270

**WIRING AND BATTERIES REQUIRED**

*4 wires common to all Inter-phones .....	270
1 wire for each suite Inter-phone, and	
3 extra wires for connecting battery, vestibule, janitor or laundry Inter-phones .....	270
Batteries to furnish current for talking, ringing and operating door opener, 1 door opener, miscellaneous installing material ..	270
*One common wire can be omitted if door opener is not required.	

##### System No. 20-G

**SERVICE**

Vestibule can call apartments and janitor, apartments can open door and call janitor, and janitor can call apartments.

**APPARATUS, WIRING AND BATTERIES REQUIRED**

Same as in System No. 20-F.

##### System No. 20-H

**SERVICE**

Vestibule can call apartments and janitor, apartments can open door and call janitor and laundry. Janitor and laundry can call apartments.

**APPARATUS REQUIRED**

	See Page
1 No. 1520U vestibule Inter-phone .....	269
1 or more No. 3 letter boxes .....	269
3 or more suite Inter-phones	
No. 1327K non-flush, wood type, or	} 269
No. 1339C flush, metal type	
1 No. 1327T janitor's Inter-phone .....	270
1 No. 1327T laundry Inter-phone .....	270
2 push button blocks (each to contain one button for each suite Inter-phone) .....	270

**WIRING AND BATTERIES REQUIRED**

*5 wires common to all Inter-phones .....	270
1 wire for each suite Inter-phone .....	270
3 extra wires for connecting battery, vestibule, janitor's and laundry Inter-phones .....	270
Batteries to furnish current for talking, ringing and operating door opener, 1 door opener, miscellaneous installing materials ..	270
*One common wire can be omitted if door opener is not required.	

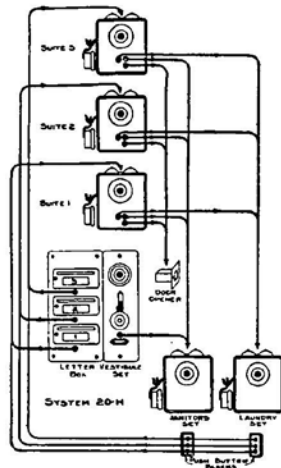

## INTER-PHONES

### Systems for Apartment Houses

#### System No. 20 (Continued)

#### Vestibule Equipment

This consists of one Vestibule Inter-phone and any number of letter boxes, depending upon the number of suite Inter-phones installed. One letter box will care for three suite Inter-phones.



No. 3 Letter Box

#### VESTIBULE INTER-PHONES

The vestibule Inter-phone in System No. 20 consists of a flush mounting, brush brass finished face plate with a push button for signaling the janitor. The metal transmitter mouthpiece is embossed and cannot be broken or removed.

Code	List Price
No.	Each
1520U . . . . .	\$23.00

Size of face plate, 3 $\frac{1}{2}$  inches wide, 12 $\frac{7}{8}$  inches long.

#### LETTER BOXES

Each letter box consists of a brush brass finished face plate to which three letter box compartments are attached. A push button for signaling the suite to which the compartment is assigned is mounted below the plate glass window of each letter box compartment. *The plate glass window, the extra wide letter opening, the card holder inside the box and the push button mounted below each compartment are exclusive features.*

Code	List Price
No.	Each
3 Letter box . . . . .	\$19.00

Size of face plate, 5 $\frac{7}{8}$  inches wide, 12 $\frac{7}{8}$  inches long.



No. 1520 Type Vestibule Inter-phone

### Suite Inter-phones

#### WALL TYPE

**Wooden Case with Golden Oak Finish and Nickel Trimmings.**

Code			List Price
No.	Mounting	Capacity	Each
1327U	Non-flush	1 button (unmarked)	\$10.50
1327NM	Non-flush	2 buttons (marked "Jan." and "Door")	12.50
1327K	Non-flush	4 buttons (can be marked when installed)	18.20

Size of cabinet, 5 $\frac{3}{4}$  inches wide, 6 $\frac{7}{8}$  inches long, 3 $\frac{1}{4}$  inches deep.



No. 1327 Type Wall Inter-phone

**Metal Case with Brush Brass Finished Face Plate and Metal Outlet Box.**

Code			List Price
No.	Mounting	Capacity	Each
1339H	*Flush	1 button (unmarked)	\$13.20
1339AM	*Flush	2 buttons (marked "Jan." and "Door")	16.00
1339C	*Flush	4 buttons (can be marked when installed)	24.80

Size of face plate, 5 $\frac{1}{8}$  inches wide, 8 $\frac{1}{8}$  inches long.

\*Metal wall box furnished.



No. 1339 Type Wall Inter-phone

## INTER-PHONES

### Systems for Apartment Houses

#### System No. 20 (Continued)

#### Janitor's, Laundry and Tradesmen's Inter-phones

If it is desired that the apartments shall be able to call the janitor or laundry, but that the latter two shall not be arranged for calling back the apartments the following Inter-phone should be used.

##### Wooden Wall Inter-phone with Golden Oak Finish and Nickel Trimmings

Code No.	Mounting	List Price Each
1327T	Non-flush	\$11.20

Size of cabinet, 5 $\frac{3}{4}$  inches wide, 6 $\frac{3}{8}$  inches long, 3 $\frac{1}{4}$  inches deep.

##### Push Button Blocks

If it is desired that the apartments shall be able to call the janitor or laundry, and these latter Inter-phones shall be arranged for calling back the apartments, it is recommended that a push button block be associated with the above 1327T Inter-phone allowing one push button to each suite Inter-phone in the system. The block can be mounted conveniently beside the instrument. This arrangement should also be used for the tradesmen's stations.

Code No.	Capacity	List Price Each
4A	4 buttons	\$3.60
6A	6 buttons	3.90
8A	8 buttons	5.00
10A	10 buttons	6.00
12A	12 buttons	7.20
14A	14 buttons	8.40
16A	16 buttons	9.60
20A	20 buttons	11.50

### Wiring Requirements

For connections between the various stations of any of the No. 20 system combinations either cable or loose wires can be used, depending largely upon the layout of the building. Where there is a long run of a large number of wires, as in the case of the vertical riser from floor to floor, it may be found economical to use cable, and to install cable terminal or connecting blocks at all the distributing points. For connecting the Inter-phones of the various apartments to these distributing points, loose wires (No. 20 or No. 22 B.&S.) should be used. The number of wires required by each system has been outlined on the preceding pages, the total number depending upon the number of suite stations required in each case. This information should be used when selecting the cable. A complete list of cable is given on page 52.

#### CABLE TERMINALS

Cable terminals or connecting blocks should be used at all distributing points where the cable conductors are distributed by loose wires to the various apartment stations. Where a large number of wires are to be connected, cable terminals are more suitable. For a small number of wires connecting blocks will be satisfactory.

Cable terminals are listed on page 55.

Connecting blocks are listed on page 58.

### Battery Requirements

For the operation of each system a battery of not more than five Blue Bell dry cells is required. These can be placed in the basement or any other accessible place.

### Door Opener

If a door opener is included in the system, additional dry cells will be required. The number of these depends upon the working of the opener and the adjustment of the door. Generally 2 or 3 cells have been found sufficient for this purpose. Any standard type of door opener may be used.

## INTER-PHONES

### Annunciator System No. 18

The No. 18 Inter-phone Annunciator System is designed to provide the service required in hotels, clubs, Y. M. C. A. buildings, schools, hospitals, asylums, prisons, and in fact wherever it is found desirable to establish communication between a central point and a large number of points in one or several buildings. No connection can be made between this system and a public telephone system.

The system consists of one centrally located Inter-phone equipment called the "Master Station," to which are connected a number of other Inter-phones called "Outlying Stations."

#### OPERATION

The master station equipment is a combination of an annunciator and a hand set type Inter-phone. The annunciator consists of a number of drops and jacks (one of each for every outlying station in the system), a cord and plug, and a hand set Inter-phone. The associated drops and jacks are provided with corresponding numbers. FROM THE MASTER STATION IT IS POSSIBLE TO SELECT AND RING ANY ONE OF THE OUTLYING STATIONS IN ORDER TO CARRY ON CONVERSATION. This is done by inserting the plug into the jack bearing the number of the outlying station wanted and depressing a push button mounted on the front of the annunciator.

Each outlying station is provided with one push button which, when depressed, will ring the bell of the master station, and at the same time operate an annunciator drop bearing a number corresponding to that of the station calling. In response to this signal, the plug of the annunciator cord at the master station should be inserted in the jack corresponding to the operated drop. This connects the calling outlying station to the master station Inter-phone.

Should the calling outlying station wish to converse with another outlying station, a connection can be established by means of a pair of connecting cords consisting of two cords, each terminating in a plug. This connection is effected as follows:

After having learned the number or name of the party desired, the annunciator plug should be withdrawn from the jack of the party calling and inserted into the jack of the party desired. Then the push button on the annunciator should be depressed to ring the bell of the station wanted. After having secured an answer from that station, the annunciator plug should again be removed and the two connecting cord plugs inserted into the jacks of the calling and the called parties.

No supervisory features, however, are provided to indicate the termination of such conversations. This arrangement should therefore only be used as an emergency measure for connecting outlying stations. (Where a comparatively large number of connections are required between outlying stations, the No. 1801 lamp signal P.B.X. switchboard is recommended.)

#### CAPACITY

This system provides for one master station and 10 to 70 or more outlying stations.

#### TYPES OF INSTRUMENTS

WALL or HAND SET type Inter-phones can be used interchangeably in the same system.

### Master Station Equipment

The Master Station Equipment consists of an annunciator and a hand set type Inter-phone.

## INTER-PHONES

### Annunciator System No. 18 (Continued)

#### Master Station Equipment (Continued)

**ANNUNCIATOR**

Wooden case with oak finish. Other finishes can be furnished at slight increase in price. Drops and jacks will be numbered from one up, unless otherwise specified.

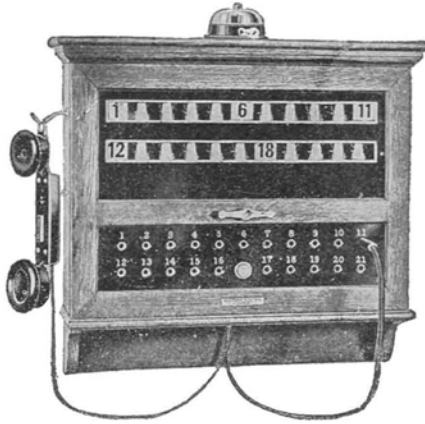

**Master Station Annunciator**

List No.	No. of Drops	Arrangement of Drops		Outside Dimensions in Inches			List Price Each
		Across	Down	Width	Height	Depth	
1028	10	5	2	23 1/4	12 1/2	5 3/4	\$61.20
1029	12	6	2	23 1/4	14	5 3/4	72.60
1030	18	9	2	23 1/4	18 1/2	5 3/4	90.60
1031	20	10	2	23 1/4	20	5 3/4	97.20
1032	24	12	2	23 1/4	23	5 3/4	116.70
1033	30	10	3	29 1/2	20	5 3/4	134.34
1034	36	12	3	29 1/2	23	5 3/4	159.96
1035	42	14	3	29 1/2	26	5 3/4	185.60
1036	48	12	4	34 1/2	23	5 3/4	211.20
1037	56	14	4	34 1/2	26	5 3/4	237.48
1038	60	12	5	40 3/4	23	5 3/4	254.02
1039	70	14	5	40 3/4	23	5 3/4	295.38

For larger sizes, add per drop and jack \$4.20.

NOTE: Each of the above list numbers covers the annunciator only and does not include the Inter-phone, which must be ordered separately.

**HAND SET TYPE INTER-PHONES FOR ANNUNCIATOR**

This presents one of the most convenient types of talking equipment. The transmitter and receiver are a part of the hand set, which is held and operated with one hand, leaving the other free. A bar marked "Press to Talk" is mounted in the hand set handle and is held down by the natural position of the hand while conversing. When not in use the hand set can be hung on a hook or laid down in any position. The finish of the hand set is black, and the cord attached to it is 3 feet long.

Code No.		List Price Each
1003K	Hand set.....	\$8.80

**Hook**

A No. 141A hook can be used in connection with the hand set, the hook to be screwed into the side of the annunciator.

Code No.		List Price Each
141A	Hook.....	\$0.03

**CONNECTING CORDS**

The master station annunciators are equipped with one cord and plug. If intercommunication between outlying stations is desired, one or two pairs of connecting cords should be used, as described under "Operation." These cords can be used with any one of the master station annunciators and should be specified when ordering the annunciator.

For one pair of connecting cords, add \$6.00.

For two pairs of connecting cords, add \$12.00.

## INTER-PHONES

### Annunciator System No. 18 (Continued)

#### Outlying Stations

##### WALL INTER-PHONES

Wooden case with golden oak finish and nickel trimmings.

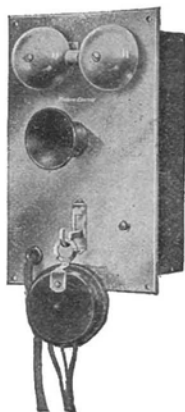

No. 1338 Type  
Wall Inter-phone

Code No.	Mounting	List Price Each
1327AB	Non-flush	\$10.50

Size of cabinet  $5\frac{3}{4}$  inches wide,  $6\frac{7}{8}$  inches long,  $3\frac{1}{4}$  inches deep.

**Metal case with brush brass finished face plate and metal wall box.**

Code No.	Mounting	List Price Each
1339R	*Flush	\$13.20

Size of face plate  $5\frac{1}{8}$  inches wide x  $8\frac{1}{8}$  inches long.

\*Metal wall box furnished.



No. 1327 Type  
Wall Inter-phone

##### HAND SET INTER-PHONES

The hand sets used for the outlying stations have the same general construction as those described under "Master Station Equipment." They, however, require apparatus boxes containing the connecting terminals, buzzers, etc.

Two types of apparatus boxes can be furnished:

1. Round boxes arranged for non-flush mounting, with black finished metal cover and nickel hook—approximate size  $3\frac{1}{8}$  inches diameter by  $1\frac{5}{8}$  inches deep.
2. Metal boxes arranged for flush mounting, intended to be set in the wall and equipped with brush brass finished face plate.

Code No.	Mounting	List Price Each
6042L	Flush	\$15.10
*6042G	Flush	14.40
6043G	Non-flush	15.60

\*No. 6042G is same as 6042L, but without face plate and wall box. See note 2 at the bottom of page 243.



No. 6042 Type  
Hand Set  
Inter-phone



No. 6043 Type  
Hand Set  
Inter-phone

#### Wiring and Battery Requirements

For connections between the outlying stations and the master station, either cable or loose wires can be used, depending largely upon the layout of the system. There will be required one wire common to all stations in the system, and, in addition, two individual wires between the master and each of the outlying stations. Where there is a long run of a large number of wires, it will be found economical to use cable, and to install cable terminals or connecting blocks at all distributing and junction points. From there, the installation can be continued by means of loose wires to the various outlying stations. The size of cable and the number of connecting blocks required should be determined by the installer in accordance with the information furnished in our booklet, "Inter-phone Installing Instructions."

Cables are listed on page 52.

Cable terminals are listed on page 55.

Connecting blocks are listed on page 58.

Five or more Blue Bell dry cells are necessary for operating the system. The cells can be placed in the basement or any other accessible place.

Blue Bell dry cells are listed on page 17.

Detailed information covering wiring diagrams of system and Inter-phones, installing instructions etc., can be found in our booklet, "Inter-phone Installing Instructions," which will be furnished upon request.

# INTER-PHONES Annunciator System No. 18 (Continued)

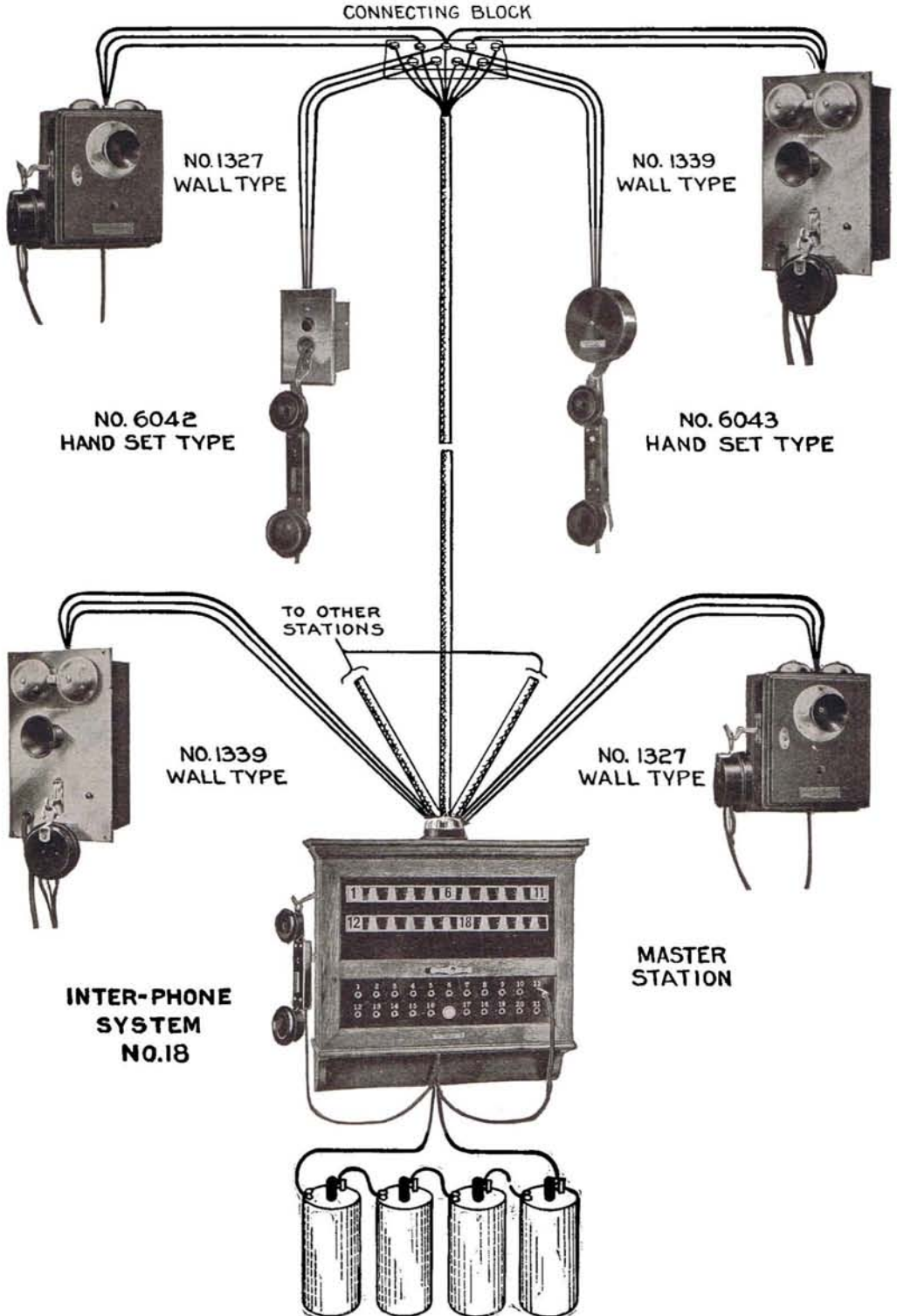

# INTER-PHONES

## Inter-phone Outfits

Where intercommunication is desired between two points in the home or in business, Western Electric Inter-phones can be furnished in "a-pair-in-a-package" outfits; that is, two Inter-phones complete with all the installing materials and instructions necessary to put them up. The outfits do not, however, include batteries, which must be ordered separately. For average conditions four or five dry cells will be sufficient.

This standard package idea for Inter-phones has been devised as a means of assisting purchasers in selecting the proper equipment for their needs without requiring them to make a study of the subject. At the same time it assures them of getting uniformly good materials, and in the proper amounts. The outfits are packed in a box ready to be sold over the counter or mailed by parcel post.

### Outfit No. 14

This consists of two wall type Inter-phones suitable for a private telephone line between house and barn or garage, or for a line that is wholly within a house. It may also be used in offices or shops between two buildings or in one building.

**Either station can ring and talk to the other.**

The Inter-phones are the same as those used for Inter-phone System No. 15. The instruments are of wood, arranged for non-flush mounting and finished in golden oak. Concise and fully illustrated instructions for installing are included in every package.

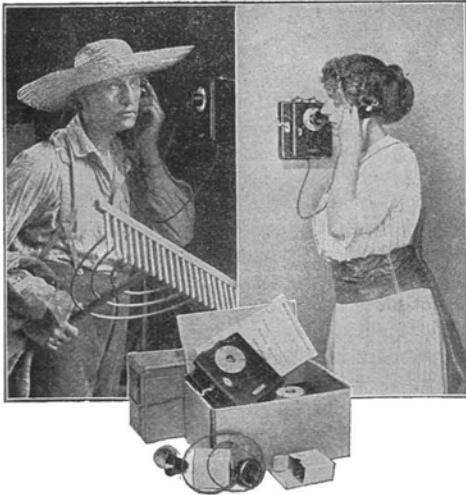

No. 14 Outfit

Outfit No.	Description	List Price
14	Includes two wall type Inter-phones in one box but no installing or wiring material. . . . .	\$23.20
14A	For use where the wiring is to be run entirely under cover and not exposed to moisture or weather. Includes one No. 14 outfit in one box, and another box containing 75 feet of insulated 3 conductor copper wire, two battery connectors, insulated nails for fastening wires, and illustrated installing instructions. . . . .	26.00
14B	For use where the wiring is to be run in the open between or outside of buildings, and exposed to weather and moisture. Includes one No. 14 outfit in one box, and another box containing 150 feet of outside 3 conductor copper wire, two brackets with screws, hooks and knobs to attach wires to building, two porcelain tubes to insulate wires when entering building, two battery connectors, 25 insulated nails for fastening wires inside building, and illustrated installing instructions. . . . .	32.00

## INTER-PHONES

### Outfit No. 15

This consists of two **Hand Set Type Inter-phones** suitable for the same class of service for which the No. 14 type outfit is intended. The Inter-phones are identical with the non-flush type hand sets used in Inter-phone System No. 15.

Either station can ring and talk to the other.

The instruments are finished in black with transmitter and receiver on one handle, and equipped with a small non-flush apparatus box. Complete instructions for installing are included in each package.



No. 15 Outfit

Outfit No.	Description	List Price Each
15	Includes two hand set type Inter-phones in one box but no installing or wiring material.....	\$27.20
15A	For use where the wiring is to be run entirely under cover and not exposed to moisture or weather. Includes one No. 15 outfit in one box, and another box containing 75 feet of insulated 3 conductor copper wire, two battery connectors, insulated nails for fastening wires, and illustrated installing instructions.....	30.00
15B	For use where the wiring is to be run in the open between or outside of buildings, and thus exposed to weather and moisture. Includes one No. 15 outfit in one box, and another box containing 150 feet outside 3 conductor copper wire, two brackets with screws, hooks and knobs to attach wires to buildings, two porcelain tubes to insulate wires when entering building, two battery connectors, 25 insulated nails for fastening wires inside building, and illustrated installing instructions.....	36.00

### Outfit No. 16

Two **Hand Set Type Inter-phones** are furnished with this outfit, which is intended to be used for converting any existing bell, buzzer or annunciator circuit into a practical working telephone system. This can be done by using the existing wires, bell and batteries, replacing the push button with one hand set and connecting the other hand set to the wire near the bell. **As only one bell is used, calls can be made in one direction only.** An outfit of this type placed in the office makes it unnecessary for the clerk or office boy to run back and forth when file information is required by the executive.



No. 16 Outfit

Outfit No.	Description	List Price Each
16A	For use with any existing circuit consisting of one bell or buzzer and one push button. Includes two hand set type Inter-phones, two connecting blocks with mounting screws, 25 feet of insulated twisted pair copper wire (to connect the Inter-phones to the existing wiring), 20 insulated nails for fastening wires, two hooks for holding hand sets and illustrated installing instructions.....	\$17.50

## INTER-PHONES

### Outfit No. 16 (Continued)

If the existing bell, buzzer or annunciator circuit consists of two or more push buttons, a No. 16-A outfit should be used—one hand set for the bell, buzzer or annunciator station, the other to replace one of the push buttons—and one No. 16-B Inter-phone outfit for each additional push button.

Outfit No.	Description	List Price Each
16-B	To be used in addition to No. 16-A outfit if existing bell, buzzer or annunciator circuit has two or more push buttons. Includes one hand set type Inter-phone, one connecting block with mounting screws, 12 feet of insulated twisted pair copper wire, 10 insulated nails for fastening wires, one hook for holding hand set, and illustrated installing instructions.....	\$9.30

### Outfit No 17.

This consists of two **Hand Set Type Inter-phones** with all the material required to install a simple intercommunicating system between two points not over 80 feet apart, and where the wire will be wholly indoors and not exposed to weather conditions or moisture.

When installed in accordance with the directions furnished with each outfit, **either station can call or talk to the other.** Although intended primarily for business use, the No. 17 outfit can be used equally well in the home.



**No. 17 Outfit**

Outfit No.	Description	List Price Each
17	Includes two hand set type Inter-phones, two connecting blocks with mounting screws, 80 feet of insulated twisted pair copper wire, 60 insulated nails for fastening wire, two hooks for holding hand sets, two bells, two battery connectors, and illustrated installing instructions.....	\$22.00

TELEPHONE ARMS

No. 1020 Type

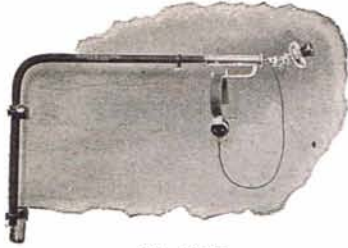

No. 1020C



No. 1020AC

Code No.	Equipped with:	Use	List Price Each
1020C	1 No. 284W transmitter 1 No. 156W Receiver 18 ft. No. 409 cord 1 2½ ft. No. 408 cord	Train dispatching circuits at way stations. Corresponding desk stand No. 1020AB.	\$25.50
1020AC	1 No. 229W transmitter 1 No. 143AW receiver 1 8½ ft. No. 180 cord 1 2½ ft. No. 389 cord	Local or central battery service. Used on flat top desk. Corresponding desk stand No. 1020AL.	21.10

No. 1048 Type

Black finished, adjustable folding telephone arm. Overall length from center of mounting rod—closed 9¾ inches; extended 24½ inches.

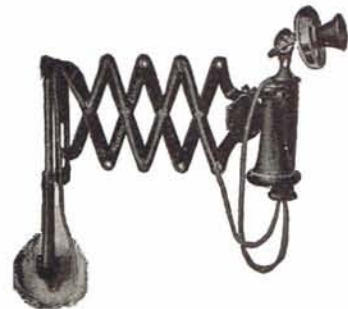

No. 1048AB



No. 1048DC



No. 1048EA

Code No.	Description	Use	List Price Each
1048AA	Equipped with a No. 329W transmitter, No. 143AW receiver, 6 ft. No. 180 cord, 2½ ft. No. 389 cord. Mounts on side of roll top desk.	Local or central battery service. Corresponding desk stand No. 1020AL.	\$16.00
1048AB	Same as No. 1048AA except mounts on wall or side of flat top desk.		16.00
1048AC	Same as No. 1048AA except mounts on top of flat top desk.		16.00
1048DA	Equipped with a No. 280W transmitter, No. 156W receiver, 8 ft. No. 409 cord, 2½ ft. No. 408 cord. Mounts on side of roll top desk.	Train dispatching circuits at way stations. Corresponding desk stand No. 1020AB.	20.30
1048DB	Same as No. 1048DA except mounts on wall or side of flat top desk.		20.30
1048DC	Same as No. 1048DA except mounts on top of flat top desk.		20.30
1048DD	Same as No. 1048DA except mounts on wall in way stations where it is desired to place a flat top desk against the wall.		20.30
1048EA	Equipped with a No. 291W transmitter, No. 171W receiver, 6 ft. No. 406 cord, 2½ ft. No. 389 cord. Mounts on side of roll top desk.	Series central battery service. Corresponding desk stand No. 1020AH.	16.30
1048EB	Same as No. 1048EA except mounts on wall or side of flat top desk.		16.30
1048EC	Same as No. 1048EA except mounts on top of flat top desk.		16.30

TELEPHONE ARMS

No. 1048 Type (Continued)

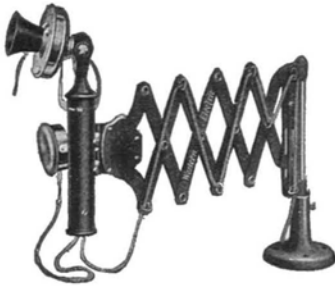

No. 1048GC

Code No.	Description	Use	List Price Each
1048GA	Equipped with a No. 280W transmitter, No. 156W receiver, 8 ft. No. 452 cord, 2½ ft. No. 345 cord. Mounts on side of roll top desk.	Train dispatching at way stations with a desk set box employing a four conductor cord and an induction coil having the primary and secondary windings insulated from each other.	\$20.30
1048GB	Same as No. 1048GA except mounts on wall or side of flat top desk.		
1048GC	Same as No. 1048GA except mounts on top of flat top desk.		
1048GD	Same as No. 1048GA except mounts on wall in way stations where it is desired to place a flat top desk against the wall.		

Van Akin Telephone Arm

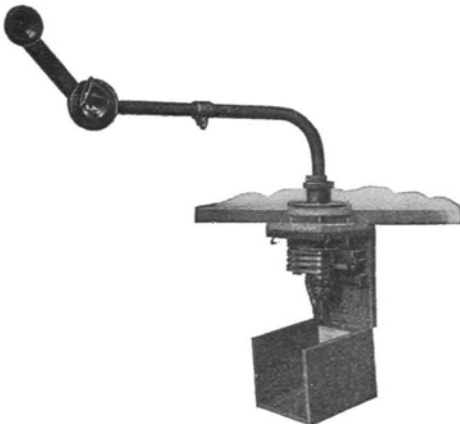

Van Akin Telephone Arm

Consists of a swinging arm equipped with transmitter and receiver on an adjustable bracket which are connected to the circuit when the arm is swung around into position for use by means of commutator switches mounted in an oak box on the under side of the table, desk or other support.

A desk set box is not required with this arm as the induction coil and other necessary equipment is mounted in the commutator box.

Includes:

- 1 transmitter (D-4609)
- 1 receiver (D-4617)
- 1 No. 21AA condenser
- 1 No. 51A retardation coil
- 1 No. 29 induction coil
- 1 No. 377 cord 4 ft. }
- 1 No. 378 cord 4 ft. } Receiver to commutator box
- 1 No. 426 cord 3 ft. 9 ins. }
- 1 No. 427 cord 3 ft. 9 ins. } Transmitter to commutator box

List price \$70.50

TELEPHONE BRACKETS

Black finished, adjustable folding arm arranged with a clamping device for holding a desk stand telephone.



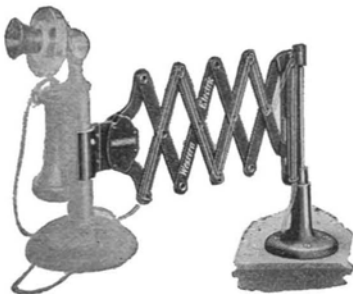



The desk stand is not included in the price of the bracket and must be ordered separately.



No. 147AC

Code No.	Mounts on:	—Length, Inches—		List Price Each
		Closed	Extended	
147AA	Side of roll top desk.	8¼	24	\$9.00
147AB	Wall or side of flat top desk.			
147AC	Top of flat top desk.			
147CA	Side of roll top desk.	10	36	12.00
147CB	Wall or side of flat top desk.			
147CC	Top of flat top desk.			

## TERMINAL PUNCHINGS

	Code No.	Material	Use	List Price per 100
	3	German Silver.	On fuse posts and fuse blocks.	\$0.80
	6	Brass, tinned ends.	For the ground side of ringing leads.	1.70
	8	Brass, tinned ends.	On double sided connecting racks.	4.10
	9	Brass, tinned ends.	On No. 10 switchboards.	.60
	13A	Brass, dip tin finish.	On double sided connecting racks.	2.00
	13B	Brass, dip tin finish.	Similar to No. 13A except 1/2 in. shorter.	2.00
	14	Brass, one end tinned.	For screw connection on one end.	4.70
	15A	Brass, tinned ends.	On one sided connecting racks.	2.40
	16A	Brass, tinned ends.	On repeating coils and retardation coils.	.80
	17A	Brass, tinned ends.	On induction coils and telephone sets.	1.00
	21A	Brass, dip tin finish.	On repeating coils, induction coils and retardation coils.	.70

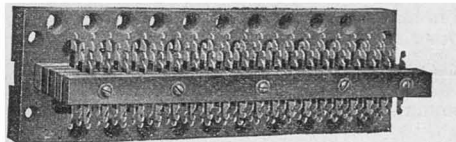

No. 35

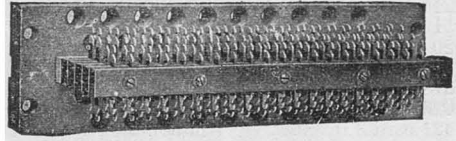

No. 36

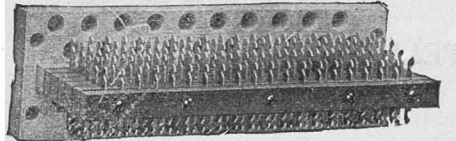

No. 37

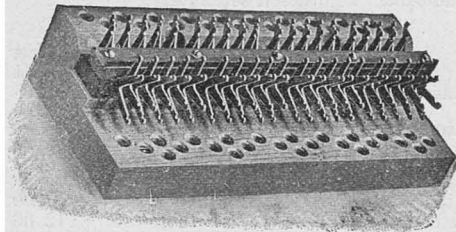

No. 53

## TERMINAL STRIPS

These strips consist of a maple base drilled for connecting wires and equipped with terminal punchings held in place by hard rubber insulating strips; except No. 53, in which case the terminals are driven into holes in the base and no connecting wire holes are provided.

### For Use on Intermediate Distributing Frame

	Code No.	Number of Terminals in Each Row	Number of Rows of Terminals	Length Strip Inches	List Price Each
	35	20	3	7 <sup>31</sup> / <sub>32</sub>	\$2.60
	36	20	4	7 <sup>31</sup> / <sub>32</sub>	3.10
	37	20	5	7 <sup>31</sup> / <sub>32</sub>	3.50
	38	20	3	6 <sup>15</sup> / <sub>32</sub>	2.10
	39	20	4	6 <sup>15</sup> / <sub>32</sub>	2.60
	40	20	5	6 <sup>15</sup> / <sub>32</sub>	3.10
	41	20	6	6 <sup>15</sup> / <sub>32</sub>	3.50
	51	20	6	7 <sup>31</sup> / <sub>32</sub>	4.20

### For Use on Main Distributing Frame

	65	40	1	7 <sup>31</sup> / <sub>32</sub>	2.10
		(Three-way)			

### For Use on No. 9 Switchboard Section

	53	20	2	10	\$0.80
--	----	----	---	----	--------

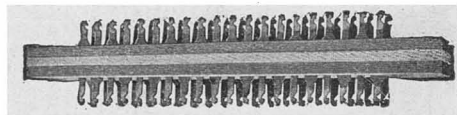

No. 53

## TESTING APPARATUS Lineman's Test Sets

### No. 1017 Type

A wooden box telephone test set equipped with regular local battery talking circuit consisting of a standard transmitter, induction coil, receiver, and a special three-cell dry battery unit.

Can be used either on magneto or central battery lines.  
Size of case  $4\frac{1}{8} \times 6\frac{3}{8} \times 8\frac{1}{8}$  inches. Birch-mahogany finish.

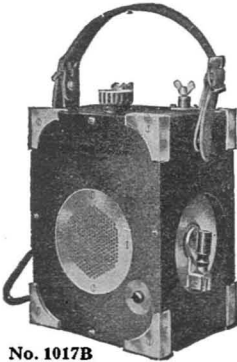

No. 1017B

Code No.	Will Ring Through Ohms	Contains	List Price Each
1017B	2500	1 No. 2D buzzer 1 No. 29B generator 1-2 ft. No. 523 cord 1 No. 13 induction coil 1 special switch 1 No. 703 Eveready Tungsten battery	
1017C	5000	1 No. 145W receiver 1 No. 266W transmitter	\$25.60
1017E	5000	Similar to No. 1017B except equipped with No. 29F generator.	30.10
		Similar to No. 1017B except equipped for use on composited lines, being provided with a No. 6000A interrupter.	40.10

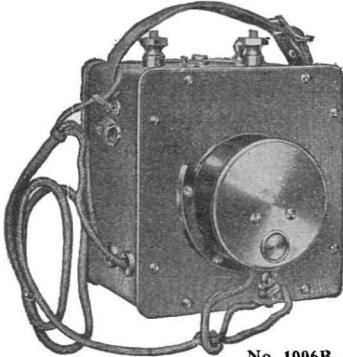

No. 1006B

### No. 1006 Type

Wooden box test set in which the No. 125W receiver is also used as a transmitter. The use of the No. 1017B is recommended on account of its higher transmitting efficiency. Cherry finish.

Code No.	Will Ring Through Ohms	Contains	Size of Case Inches	List Price Each
1006D	5000	1 No. 2A buzzer 1 No. 22B generator 1 No. 125W receiver 1 3 ft. receiver cord 1 two point switch.	$6\frac{3}{4} \times 6\frac{3}{4} \times 4\frac{1}{2}$	\$21.60

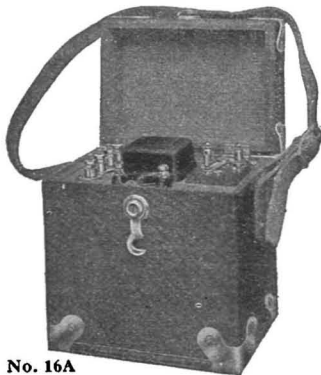

No. 16A

## Cableman's Test Sets

### No. 16A

Size of case  $7\frac{1}{8} \times 5\frac{1}{8} \times 7\frac{3}{4}$  inches.  
Oak finish with nickel trimmings.

Use	Contains	List Price Each
A tone testing set for use in splicing cables.	1 No. 31A condenser 1 No. 13115 switch 1 P. R. buzzer 4 No. 2A binding posts 6 No. R-4 Columbia dry cells*	\$20.50

### No. 1020A

Size of case  $12 \times 6\frac{3}{8} \times 10\frac{1}{4}$  inches.  
Birch-mahogany finish.

Use	Contains	List Price Each
A tone testing set for use in locating shorts and grounds in cable. Interrupted current is sent over wires in trouble and the fault located by exploring coil and receiver.	1 No. 18AC resistance 1 No. 21K condenser 1 induction coil vibrator unit 1 electro-magnetic interrupter 1 two-point battery switch 1 No. 19A test set (exploring coil) 1 instruction book 1 No. 148W receiver 4 "Blue Bell" dry cells*	\$101.30



No. 1020A

\*Batteries not furnished unless ordered.

## NO. 1407 TESTING CABINET

### General

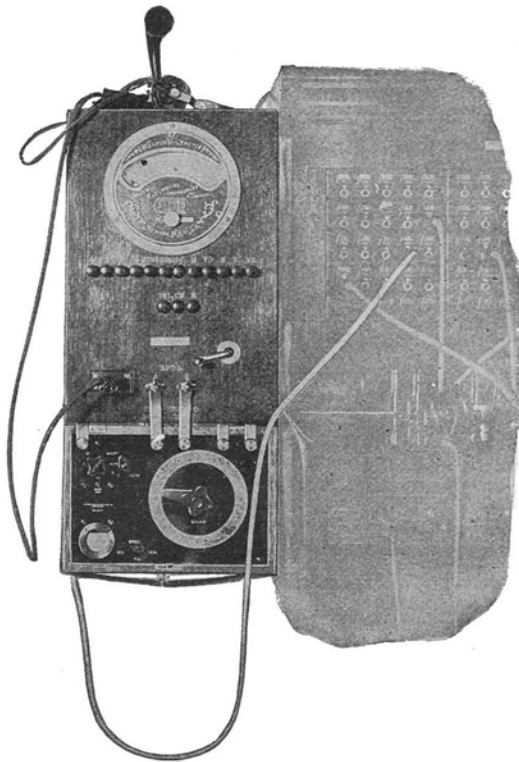

No. 1407 Testing Cabinet with No. 1407 Bridge Unit Attached to the Side of a No. 1200 Type Switchboard

The No. 1407 Testing Cabinet is a condensed wire chief's test desk that will accurately test for practically all troubles occurring in either magneto or central battery systems.

The cabinet, approximately 9½ inches deep by 12 inches wide by 18 inches high, is built of oak and richly finished.

It can be mounted in the terminal room or at the end of the switchboard, the finish of the cabinet being such that it will harmonize with our standard oak switchboard cabinets.

Tests can be easily and quickly made for grounds, crosses, short circuits, opens (that is, lack of continuity), bad joints and practically all other troubles common to the average telephone exchange system, without complicated mathematical calculations.

### Groups

The No. 1407 Testing Cabinets can be furnished in several combinations or groups to suit individual requirements.

When ordering, specify which groups are desired.

#### Group No. 1

Consists of 1 No. 1407 Testing Cabinet for local battery (magneto) systems complete, ready for voltmeter testing (except 30 volt dry cell battery), including the following circuits:

1 testing circuit, arranged for single or two-party ringing, complete with 10000-ohm Weston voltmeter, keys for making tests, testing cord, and grounding cord.

1 operator's circuit, complete with head band receiver and chest type transmitter.

NOTE: The equipment covered by the following groups is not included under Group No. 1.

#### Group No. 2

Consists of hand generator equipment for single or two-party ringing.

This group is not necessary in all cases because ringing current can frequently be obtained from the hand generator on the switchboard, alongside of which the No. 1407 Cabinet is sometimes mounted, or from the interrupter or ringing machine.

#### Group No. 3

Consists of 1 10 foot cord and No. 147 plug (or shoe) for use in testing at the protector frame. This No. 147 plug fits only our Nos. 4, 65, 78, 84, 89, 1168 and 1169 type protectors. If protectors of other than Western Electric manufacture are used, a suitable plug should be obtained from the manufacturer who made the protector.

## No. 1407 TESTING CABINET

### Groups (Continued)

#### Group No. 4

Consists of 30 Blue Bell dry cells. It will usually be found advisable to furnish the dry cells separately and not to include this group with the cabinet.

#### Group No. 5

Consists of 1 No. 1407 Testing Cabinet for central battery systems, complete. This group includes all the apparatus covered by Group No. 1, and, in addition, such other necessary equipment as to make the No. 1407 Testing Cabinet applicable for use with central battery.

NOTE: The equipment covered by the preceding (except Group No. 1) or following groups is not included in Group No. 5.

#### Group No. 6

Consists of apparatus necessary for placing howler current on the testing cord.

#### Group No. 7

Consists of incoming trunk and call wire equipment. This is used when the testing cabinet is located away from the switchboard, and enables the test man to receive and send calls.

#### Group No. 8

Consists of the necessary keys and apparatus to provide for four-party harmonic ringing.

#### Group No. 9

Consists of the necessary keys and apparatus to provide for four-party pulsating ringing.

#### Group No. 10

Consists of hand generator equipment for four-party pulsating ringing. This group is not necessary in all cases of four-party pulsating ringing, as ringing current can frequently be obtained from the hand generator on the switchboard, alongside of which the cabinet is sometimes mounted, or from the interrupter or ringing machine.

## No. 1407 Bridge Unit

The No. 1407 Bridge Unit has been developed to satisfy a persistent demand for a more accurate means of making resistance measurements than is possible with a voltmeter. It consists of a Wheatstone bridge outfit which is designed to line up and attach by means of the No. 1407B Bracket Unit to the bottom of a No. 1407 Testing Cabinet.

With this equipment Murray and Varley loop tests as well as straight resistance measurements can be quickly made in addition to the regular voltmeter testing possible with the No. 1407 Testing Cabinet.

Unknown resistances can be read directly from the scale without referring to tables or other data, and such readings are accurate up to one-half of one per cent.

This Bridge Unit is easily detached from the Testing Cabinet by loosening the binding posts holding the bracket unit straps and moving the bridge about an inch to the right. When removed it can be used as a portable bridge and carried about as desired from exchange to exchange. A cover and carrying strap are provided for this use. See listing and prices on page 284.

## TESTING APPARATUS

### Artificial Lines and Cable



Artificial Lines and Cable

These instruments are designed for use in telephone transmission and telegraph line testing.

The one illustrated contains the necessary resistance and capacity to represent a total length of 32 miles of standard No. 19 B.&S. gauge cable, having a loop resistance of 88 ohms per mile and a mutual electrostatic capacity of .060 M.F. per mile, and is so arranged by means of switches that various sub-divisions to form any length between 1 mile and 32 miles can be made.

Other standard sizes having a total length of 1, 5 or 10 miles can be furnished.

These artificial lines and cables are made to order owing to the varying conditions that are encountered in practice. They are available in standard or special sizes, as desired.

Prices and details upon application.

### Peerless Improved Lineman's Fault Finder

This instrument is especially adapted for the use of wire chiefs in locating crosses, grounds and other cases of line and cable trouble, as well as for straight resistance measurements.

It may be used either as a portable or stationary set and is arranged for mounting vertically or horizontally on desk or wall.

Unknown resistances can be read directly from the scale thus avoiding reference to tables or other data in working out resistance problems.

It is simple, accurate and dependable when an accuracy not higher than  $\frac{1}{2}$  of 1% is desired.

Test set No. T-2062 is the same as the Western Electric No. 1407A except that it has contacts and other facilities for connecting it directly to the No. 1407 testing cabinet.



Peerless Fault Finder

List No.		List Price Each
T-2062	Peerless improved fault finder.....	\$144.50
T-2063	Sole leather carrying case.....	18.00

### No. 1407A Bridge Unit

Used in connection with a No. 1407 testing cabinet, This bridge unit is the same as No. 2062 Peerless Improved Lineman's Fault Finder above described, except that it has facilities for attaching direct to the No. 1407 testing cabinet by means of the No. 1407B bracket supporting unit. A further and more comprehensive description of this equipment will be found in connection with the No. 1407 testing cabinet listed on the preceding pages.

List No.		List Price Each
1407A	Western Electric Bridge Unit.....	\$136.50
1407B	Bracket Supporting Unit.....	7.40

### Direct Reading Ohmmeter

These instruments are built in the laboratory type open form, or the combination laboratory and portable type equipped with a cover which can be closed and locked and the instrument used as a portable. The cover in this case is on detachable hinges so that it may be taken off and the set used in the laboratory. The ohmmeters are made with single, double and triple scale and are built complete with contained standard galvanometers and with or without self-contained battery.

Price applications should state range and style required.

Telephone Apparatus and Supplies



Direct Reading Ohmmeter

## TESTING APPARATUS

### Peerless Portable Plug Set



Peerless Portable Plug Set

The bridge arms in this set are reversible and are arranged as follows:

Bridge coils in "A" arm have values of 1, 10 and 100 and are accurate to 1/20 of 1%.

Bridge coils in "B" arm have values of 10, 100 and 1,000 and are accurate to 1/20 of 1%.

The rheostat coils are arranged in units, tens, hundreds and thousands with multiples of 1, 2, 2 and 5 of each denomination, producing a total of 11,000 ohms. By using the 1 to 1000 ratio on the bridge, a range of 11 megohms in single ohm steps may be obtained. The rheostat coils are accurate to 1/10 of 1%.

Provision is made for an outside battery in case a higher E.M.F. than that of the cells in the set is required.

The set is designed for ease in reading. The bridge is at the top, out of the way of the tester. The plugs are in vertical columns, beginning with the thousands at the left-hand side and followed by the hundreds, tens and units. When balance is obtained, the desired result is obtained by adding the values of the resistances plugged out, in the same way that a column of figures is added.

The case is of highly polished mahogany and the metal work of polished brass, gold lacquered.

The weight, complete, is 7¾ lbs.; the size, 9½ x 5¾ x 5½ inches.

List No.		Price List Each
T-2010	Peerless plug type testing set . . . . .	\$120.00
T-2016	Sole leather carrying case for T-2010 . . . . .	18.00
T-2040	Folding tripod for supporting T-2010 in street . . . . .	18.00

### Government Standard Testing Set

Government standard testing set, made in strict accordance with the rigid requirements of the United States Navy Specifications, 17-T2.

A high-grade type of "plug-in" set.

Battery consists of 6 silver chloride cells.

Bridge values in the A and B arms, 1, 10, 100, 1000 and coils are accurate to 1/20 of 1%. Rheostat on the decade plan, with 10 coils on each decade, of the values of units, tens, hundreds and thousands.

List No.	
T-2070	Peerless G. S. decade portable testing set.
T-2085	Carrying case of sole leather, with shoulder strap.

Price on request.



Government Standard Testing Set

### The Peerless Switch Dial Set

The bridge arms in this set have values of 1, 10, 100 and 1000 in each arm. The coils are accurate to 1/20 of 1%.

Rheostat has four dials of 10 coils each, with values of units, tens, hundreds and thousands. The coils are adjusted to an accuracy of 1/10 of 1%.

An Ayrton shunt is part of the set apparatus. Provision is made for outside galvanometer and outside battery. Any commercial cell may be used for the latter.

A specially designed switch, with negligible contact resistance, is furnished.

The sets are equipped with quick make and break switches for changing from test to test.

Weight, complete, 7¾ lbs. Size, 9½ x 5¾ x 5½ inches.

The case is of highly polished mahogany and the metal work of polished brass, gold lacquered.

List No.		List Price Each
T-2000	Peerless switch dial decade testing set . . . . .	\$170.00
T-2015	Sole leather carrying case for T-2000 . . . . .	18.00
T-2020	Flexible contact clutches for gripping heavy conductors . . . . .	9.00
T-2040	Folding tripod for supporting T-2000 in street . . . . .	18.00

285

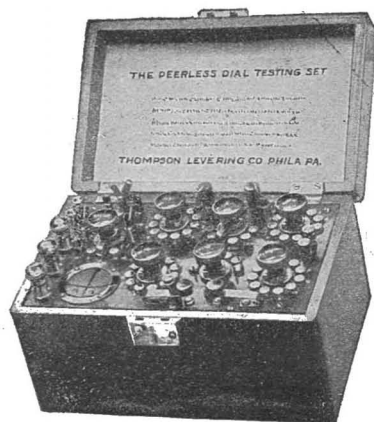

Peerless Switch Dial Set  
Telephone Apparatus and Supplies

## TESTING APPARATUS

### Switch Dial Decade Test Set

#### CI-2011



**Switch Dial Decade Test Set**

This instrument is of the standard Wheatstone Bridge type, and has in its rheostat four decades. The coils have values of units, tens, hundreds and thousand ohms.

The bridge is controlled by a single multiplying dial, giving ranges varying from .001 to one thousand times the rheostat readings. The rheostat coils are accurate to 1/10 of 1% and the bridge arm coils to 1/20 of 1%.

A new method of reading resistance is used, in which the values of the coils appear in a window, only one value showing at a time. Another feature is the new test switch, which makes it only necessary to turn the indicator to the test desired.

All contacts are underneath the top of the set.

The galvanometer is of the high sensibility and dead beat D'Arsonval type.

A commercial battery is used.

The set has been simplified so that no technical education is required to operate it.

List No.	Description	List Price Each
CI-2011	Peerless switch dial decade testing set . . . . .	\$120.00
CI-2012	Sole leather carrying case for CI-2011 . . . . .	18.00
CI-2013	Flexible contact clutches for gripping heavy conductors . . . . .	9.00
CI-2014	Folding tripod for supporting CI-2011 for field work . . . . .	18.00

### Chloride of Silver Testing Battery

(For description see page 18)

#### Plug Type Resistance Box and Wheatstone Bridge

The resistance units in the rheostat are adjusted to an accuracy of 1/10 of 1 per cent. and the bridge arms to 1/20 of 1 per cent. These are built on the well-known post office plan, and are very satisfactory for ordinary testing work. The coils are carefully treated and aged, and are wound on wooden spools. The plugs are carefully made to an exact taper, and will fit in the plug holes smoothly, with practically no contact resistance. The line posts are of a double-grip type, for gripping small or large sized wire, and all binding posts are of a substantial size throughout.













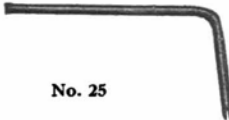

**Plug Type Resistance Box and Wheatstone Bridge**

\*F. O. B. Philadelphia, Pa.

List No.	Description	*List Price Each
T-1550	Resistance box and Wheatstone bridge. Resistance coils 1, 2, 2, 5, 10, 20, 20, 50, 100, 200, 200, 500, 1000, 2000, 2000, 5000; ratio coils—A arm 1, 10, 100 and 1000; B arm 1, 10, 100 and 1000; supplied with battery and galvanometer keys, galvanometer key having a short circuit strap . . . . .	\$68.00
T-1552	Resistance box. Resistance coils of 1, 2, 2, 5, 10, 20, 20, 50, 100, 200, 500. . . . .	34.00
T-1554	Resistance box, similar to the above, except coils of 1, 2, 2, 5, 10, 20, 50, 100, 200, 200, 500, 1000, 2000, 2000, 5000 . . . . .	51.00

## TOOLS

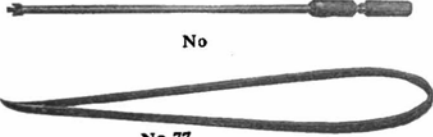
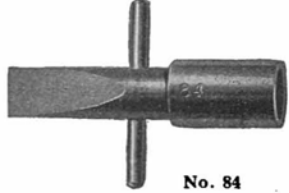
## For Central Offices

	Code No.	Use	List Price Each
	No. 25		
	No. 28		
	No. 34		
	No. 39		
	No. 40		
	No. 43		
	No. 46		
	No. 48 Tool		
	No. 50		
	No. 58		
	No. 63		
	No. 77		
	No. 84		
	No. 85		
	25	Spring adjustment of horizontal key. . . . .	\$0.50
	28	Socket wrench for $\frac{1}{4}$ in. hexagonal nuts on Nos. 4 and 65 type protectors. . . . .	.60
	34	Wrench and screw driver for $\frac{1}{8}$ in. hexagonal nuts on No. 7 type protector fuses. See No. 127 tool. . . . .	1.80
	35	Screw driver with blade $\frac{9}{16}$ in. wide. . . . .	.60
	39	Shutter support adjuster, used on drops. . . . .	.60
	40	Double screw driver for drops. One end bent at angle of 90 degrees. . . . .	.60
	43	Double wrench for $\frac{3}{8}$ in. and $\frac{1}{4}$ in. nuts. . . . .	.60
	45	Socket wrench for $\frac{5}{16}$ in. hexagonal armature adjusting nuts of relays. . . . .	1.00
	46	Removing $\frac{3}{8}$ in. hexagonal cap nuts from relays of No. 122 type. . . . .	1.00
	48	Wrench and screw driver for adjusting armature contacts of relays. Will fit $\frac{1}{4}$ in. and $\frac{7}{32}$ in. hexagonal nuts. . . . .	1.70
	50	Relay spring adjustment. . . . .	.70
	58	Handling heat coils of protectors. . . . .	1.50
	59	Long handle round nose pliers. Overall length 19 ins. . . . .	3.40
	63	Triple wrench for binding posts of transmitters and receivers. Fits $\frac{1}{8}$ , $\frac{3}{8}$ and $\frac{1}{4}$ in. hexagonal nuts. . . . .	.28
	64	Wrench and screw driver for adjusting Nos. 4 and 15 jack fasteners. . . . .	3.40
	72	Wrench and screw driver for adjusting armature contact screws. Same as No. 48 except arranged for $\frac{3}{8}$ in. and $\frac{5}{32}$ in. hexagonal nuts. . . . .	1.50
	74	Double wrench, same as No. 43 except arranged for $\frac{5}{32}$ in. and $\frac{1}{8}$ in. hexagonal nuts. . . . .	.80
	77	Holding wires to terminals of jacks for soldering. . . . .	2.00
	84	Wrench and screw driver for No. 7 type fuses. Fits $\frac{1}{16}$ in. hexagonal nuts. . . . .	.80
	85	Extracting No. 4 type lamps. . . . .	.60

TOOLS

For Central Offices—Continued

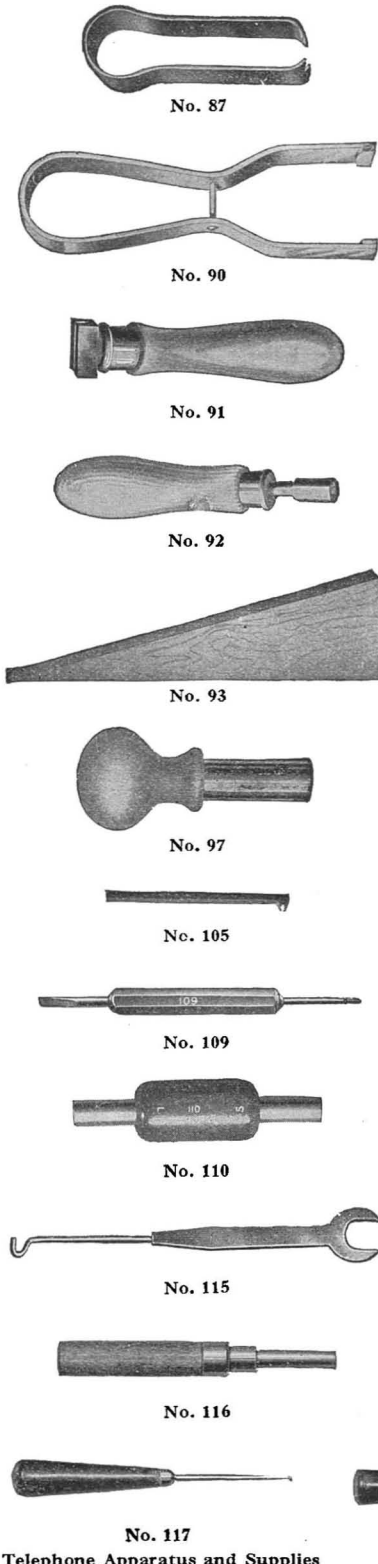

Code No.	Use	List Price Each
87	Extracting No. 8 type lamp caps.....	\$0.60
90	Removing caps of message registers.....	1.70
91	Removing cover of No. 89 type relay.....	1.00
92	Nuts on Nos. 18 and 19 type resistances.....	1.00
93	Multiple cable lifter.....	.50
96	Double screw driver for ringers.....	1.00
97	Socket wrench for $\frac{3}{8}$ in. hexagonal nuts.....	.80
102	Socket wrench for $\frac{3}{8}$ in. hexagonal nuts.....	1.10
103	Wrench and screw driver. Similar to No. 64 except arranged for adjusting No. 16 jack fastener.....	4.10
105	Adjusting springs on No. 453 type keys.....	.80
109	Combination tool for inserting and extracting shell and connecting screws of plugs.....	.60
110	Double socket wrench for No. 20 type desk stands and No. 48 type telephone arms. Fits $\frac{5}{16}$ and $\frac{9}{32}$ in. hexagonal nuts.....	.70
112	Extracting No. 2 type lamp caps and Nos. 59 and 60 type number plates. See No. 125 tool.	.60
115	Adjusting selectors for station desired.....	.50
116	Removing No. 2 type lamps.....	.60
117	Adjusting tip and ring springs of No. 92 jacks. Used with No. 118 tool for adjusting abnormally bent ring springs.....	1.00
118	With No. 117 tool for adjusting abnormally bent ring springs of No. 92 jacks.....	.70
119	Extracting and replacing sleeves of No. 193 jacks.....	On request
122	Adjusting air gap between armature and core on harmonic ringers.....	1.00
125	Removing No. 2 type lamp caps and Nos. 59 and 60 type number plates where the closeness of the centers will not permit the use of the No. 112 tool.....	1.30
127	Screw driver part of No. 34 tool.....	1.00
129	Double wrench for adjusting armature pivot screw nuts and adjusting posts of ringers. Both ends fit $\frac{1}{4}$ in. hexagonal nut.....	.60



## TRANSFORMERS

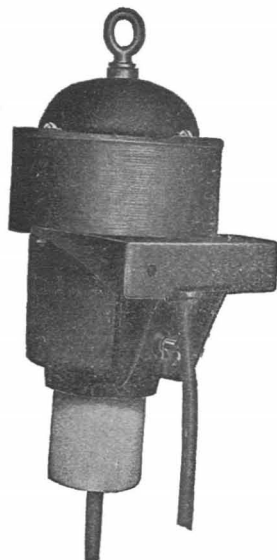

No. Y-109 Transformer

### Line Insulating Transformers

Code No.	Description	List Price Each
Y-109	This transformer is used for protection and is placed between a telephone set and the telephone line when the telephone line parallels high power transmission lines . .	\$50.00

Delivery F. O. B. Pittsfield, Mass.



No. 190546

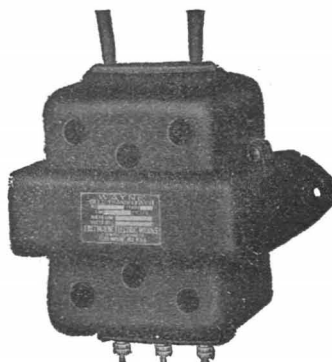

No. 190552

### Bell Ringing Transformers

Transformer No. 190546 is a small, self-contained, tamper-proof, indestructible device made especially for service in residences, flats, etc., for operating the door bells, annunciators, burglar alarms and door openers. It is to be connected to the house lighting circuit of 60 cycles, 110 volts, alternating current, and gives 12 volts across the binding posts for the bell circuit.

It will ring three 4 inch bells connected in multiple; when a 6 inch bell is to be operated two of these transformers should be used, their primaries connected in multiple across the lighting circuit and the secondaries connected in series to supply the current for the bell. With two transformers connected in this manner three 6 inch bells can be operated at one time.

The No. 190552 is designed especially for service in connection with the larger bells used in factories, public buildings, etc., which require more energy to ring them than is furnished by the transformer previously described.

It has a capacity of five 5 to 7 inch bells, or ten 2 to 4 inch transformer bells, the bells to be connected in multiple across the secondary circuit.

The No. 99192 is in construction and outward appearance similar to Transformer No. 190552, but has a capacity of three 10 to 12 inch bells, five 8 inch bells, ten 5 to 7 inch bells, or twenty 2 to 4 inch transformer bells, the bells to be connected in multiple across the secondary circuit.

The above are built to conform to the requirements of the Underwriters and bear their approval.

#### List Prices and Data

List No.	Voltage			Watts	Frequency	Height Inches	Width Inches	Depth Inches	Wt. Lbs.	List Price Each
	Primary	Secondary								
190546	110	12		10	25 to 140	6½	3½	2½	4⅝	\$2.80
99192	110	10, 20 and 30		125	40 to 140	6½	6⅞	4⅜	11½	16.50
190552	110	8, 16 and 24		60	40 to 140	5¾	5⅝	3¾	8	12.30
190885	220	12		10	40 to 140	6½	3½	2¾	5½	4.50

TRANSMITTERS

For Standard Magneto and Central Battery Telephones

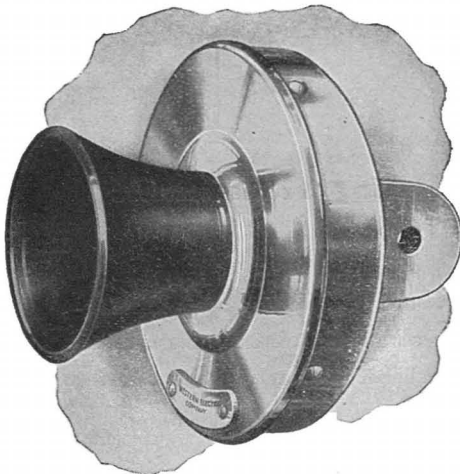

No. 311W and No. 317W



No. 297W and No. 325W

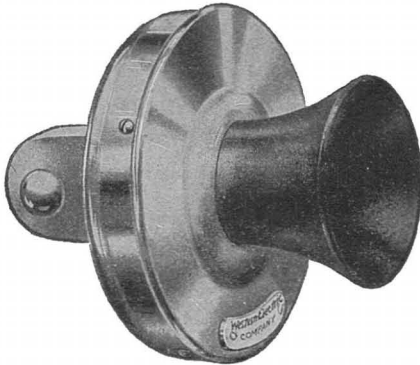

No. 329W

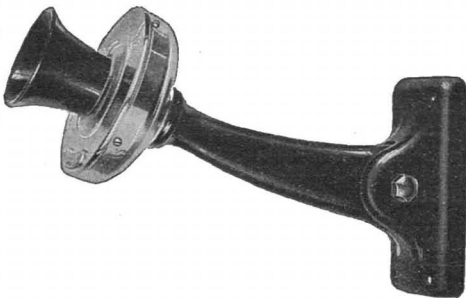

No. 350W

Telephone Apparatus and Supplies

Code No.	Description	Use	List Price Each
311W	High resistance, insulated transmitter. Provided with a mounting lug, but no clamping bolt. Nickel plated case.	Magneto and central battery metal telephones where clamping bolt is not required.	\$4.00
325W	High resistance, insulated transmitter, face only. Arranged for flush mounting. Nickel plated face.	Wooden and metal telephones where flush mounting is desired.	2.70
329W	High resistance, insulated transmitter. Provided with mounting lug and clamping bolt. Nickel plated case. Similar to No. 311W except provided with clamping bolt.	Magneto and central battery desk stands and telephone arms.	4.00
350W	High resistance, insulated, bracket type transmitter. Equipped with two cords. Nickel plated case with black finished bracket and arm.	Magneto and central battery wall telephones, requiring a bracket type transmitter.	4.20
355W	High resistance, insulated transmitter. Arranged to mount on an iron bracket of the type which forms a part of the No. 350W transmitter. Not provided with mounting lug. Nickel plated case.	Magneto and central battery wall type telephones.	3.10

For Series Central Battery Telephones

291W	High resistance, insulated transmitter. Provided with mounting lug and clamping bolt. Nickel plated case. Similar to No. 317W except provided with clamping bolt.	Series service desk stands and telephone sets where lug and bolt are required for mounting.	\$4.30
297W	High resistance, insulated transmitter, face only. Arranged for flush mounting. Nickel plated face.	Series service metal wall telephones where flush mounting is desired.	3.20
301W	High resistance, insulated bracket type transmitter. Equipped with two cords. Nickel plated case with black finished bracket and arm.	Series service wooden wall telephones.	4.30
317W	High resistance, insulated transmitter. Provided with a mounting lug, but no clamping bolt. Nickel plated case.	Series service wall telephones where clamping bolt is not required.	4.10

## TRANSMITTERS

## For Switchboards



No. 232W

Code No.	Description	Use	List Price Each
232W	High resistance, non-insulated transmitter. Arranged to be suspended by two cords. Black finish.	In connection with small switchboards as an operator's transmitter.	\$5.10
234W	High resistance, insulated transmitter. Arranged to be supported by a band around the operator's neck. This attachment is not furnished with the transmitter.	Magneto or central battery switchboards as an operator's transmitter. No. 3 type transmitter attachment is used as a support.	5.40

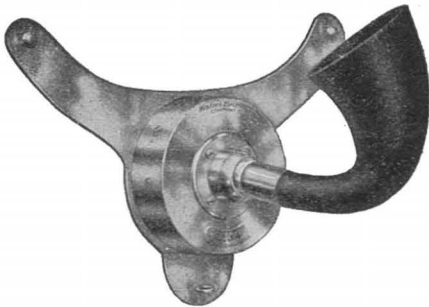

No. 234W

## For Train Dispatching Service

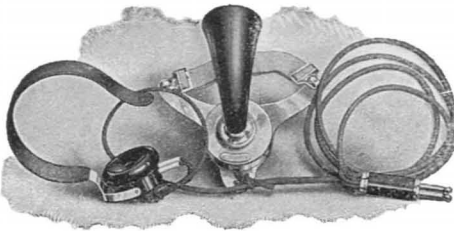
Head Telephone Set with  
No. 283W Transmitter

280W	Low resistance, insulated transmitter. Provided with mounting lug and clamping bolt. Black finish.	Nos. 1020AB and DSP desk stands and 1048 type telephone arms in train dispatching.	\$4.30
282W	Low resistance, insulated, short arm, bracket type transmitter. Mouthpiece does not project beyond edge of writing shelf. Equipped with two cords. Nickel plated case with black finished bracket and arm.	Nos. 1317W, AD, AE, AW, BC and BD telephones in train dispatching circuits.	5.00
283W	Low resistance, insulated, chest transmitter. Nickel plated case.	With No. 375 cord in dispatcher's telephone set. No. 3 type transmitter attachment is used as a support.	6.80
284W	Low resistance, insulated transmitter. Provided with mounting lug and clamping bolt. Nickel plated case.	No. 1020C telephone arm in train dispatching service.	4.30

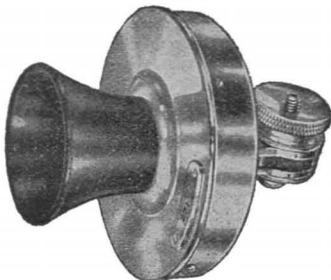

No. 284W

**TRANSMITTERS**

**For Hand Sets**



No. 244W and No. 285W

Code No.	Description	Use	List Price Each
244W	High resistance, insulated transmitter with a metal case and mouthpiece. Nickel plated.	No. 1001 type hand sets.	\$5.10
267W	High resistance, insulated transmitter.	No. 1002 type hand sets.	3.20
285W	Low resistance, insulated transmitter with a metal case and mouthpiece. Nickel plated.	No. 1001C hand sets.	4.70

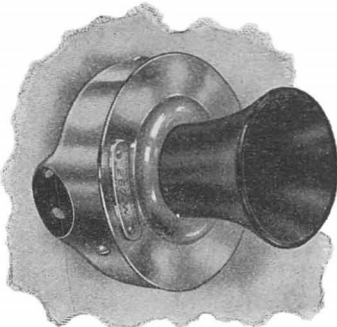

No. 267W

**For Miscellaneous Use**

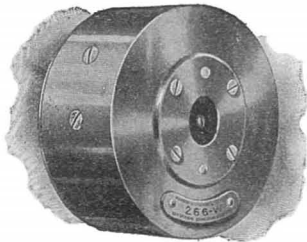

No. 266W

266W	High resistance, insulated transmitter to be fastened inside of case. Nickel plated.	No. 1017 type test sets.	\$2.60
286W	High resistance, insulated, short arm bracket type transmitter. Black finish.	Railway composite sets.	6.70
312W	High resistance, insulated transmitter. Nickel plated face with black finished metal mouthpiece.	Nos. 1336 and 1337 type mine telephones.	7.00

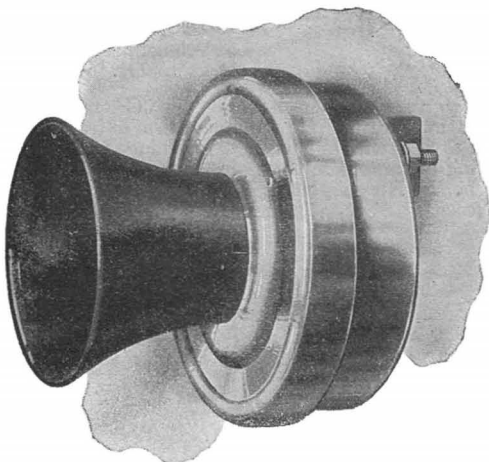

No. 312W

Telephone Apparatus and Supplies

**TRANSMITTER PARTS**

**Mouthpieces**

No.	Transmitters Used On	List Price
P-84570	Nos. 232W, 267W, 280W, 282W, 284W, 286W, 291W, 297W, 301W, 311W, 317W, 325W, 329W, 350W and 355W.....	Prices on request
P-91818	No. 234W.....	
P-91425	No. 283W.....	
P-106561	No. 312W.....	

**Rim Screws**

P-91278	No. 280W.....	Prices on request
P-91811	Nos. 282W, 283W, 284W, 291W, 301W, 311W, 317W, 329W, 350W and 355W.....	
P-180658	No. 267W.....	

## TRANSMITTER ARMS For Switchboards



No. 7A

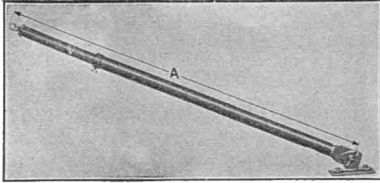

No. 19C

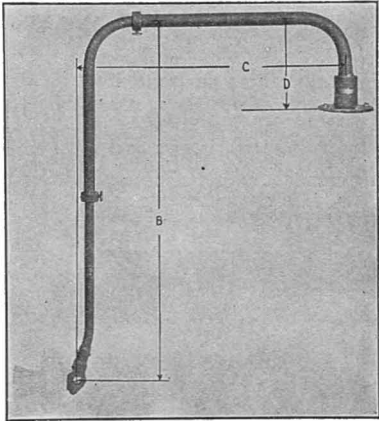

No. 50 Type

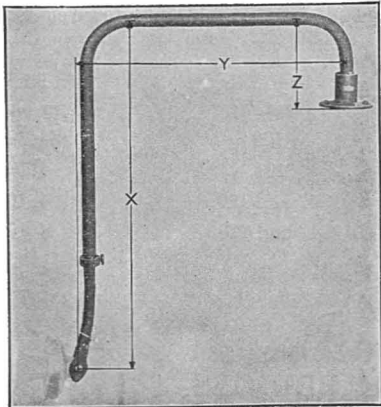

No. 51 Type

### USING SUSPENDED TRANSMITTERS

The code number does not include transmitter or cords.

Code No.	Description	List Price Each
7A	Consists of one arm, two cord escutcheons with tubes, and two No. 103 cord weights. Furnished in brass, lacquered finish unless otherwise specified. In ordering specify whether 7 in. or 13 in. cord escutcheon tubes are desired.	\$9.50
7G	Same as No. 7A except has a black lacquer finish.	9.50
19C	Oxidized copper finish. Dimension A—maximum, 29 $\frac{3}{8}$ ins., minimum 16 $\frac{5}{8}$ ins.	7.00
19D	Oxidized copper finish. Dimension A—maximum 20 $\frac{1}{16}$ ins., minimum 11 $\frac{5}{16}$ ins.	7.00

### USING TRANSMITTER WITH A LUG

The code number does not include transmitter or cords.

No. 50 and 51 type have a black finish.

#### No. 50 Type

Code No.	Dimensions, Inches						List Price Each
	B		C		D		
	Max.	Min.	Max.	Min.			
50A	24 $\frac{1}{4}$	19 $\frac{3}{4}$	22 $\frac{1}{4}$	14 $\frac{1}{4}$	5 $\frac{1}{4}$	\$6.50	
50B	17 $\frac{1}{4}$	12 $\frac{3}{4}$	22 $\frac{1}{4}$	14 $\frac{1}{4}$	5 $\frac{1}{4}$	6.50	
50C	10 $\frac{1}{4}$	8 $\frac{1}{2}$	22 $\frac{1}{4}$	14 $\frac{1}{4}$	*	} On request	

\*Minimum 5 $\frac{1}{4}$  inches, but may be increased by 1 inch steps to a maximum of 10 $\frac{1}{4}$  inches.

#### No. 51 Type

Code No.	Dimensions, Inches				List Price Each
	X		Y	Z	
	Max.	Min.			
51A	21 $\frac{1}{4}$	16	14 $\frac{3}{16}$	5 $\frac{1}{4}$	\$11.70
51B	18	12 $\frac{3}{4}$	17 $\frac{3}{16}$	10 $\frac{1}{2}$	12.20

**TRANSMITTER ATTACHMENTS**



No. 3A

Used to support the operator's chest transmitter.

Buckles are nickel finished.

No. 2A consists of one buckle only.

No. 3 type consists of two buckles and a tape strap. Overall length 21½ inches.

Code No.	Color of Strap	List Price per 100
2A		\$8.10
3A	Slate	18.90
3B	Black	18.90
3C	White	18.90

**TRANSMITTER BRACKETS**



No. 3A

Code No.	Description	List Price Each
3A	Nickel finished bracket for mounting transmitter on front of telephone set.....	\$0.34
3C	Same as No. 3A except connecting lug is omitted, is arranged for mounting an insulated transmitter.....	.32
7A	Nickel finished bracket for mounting transmitter in a semi-flush position in metal telephone sets.....	.25
8A	Black finished bracket for mounting transmitter on front of No. 1317 C type (two cell) telephone sets.....	.70

**TROUBLE CAPS**

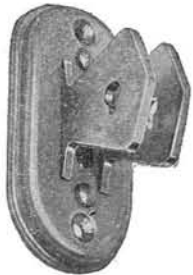

No. 8A

Split fiber tubes for slipping over a plug to designate trouble in the cord circuit apparatus.

Code No.	Color	Used With Plugs Nos.	List Price per 100
1A	Black	109	\$4.10
1B	Red	109	4.10
2A	Black	47 and 110	4.10
2B	Red	47 and 110	4.10



No. 1A

**WHEATSTONE BRIDGES**

See Testing Apparatus

# TELEGRAPH APPARATUS

## Keys



No. 531



No. 530

### Steel Lever Solid Trunnion Keys

#### "THE KEY SUPREME"

The lever is only one-half the weight of the ordinary brass lever. The lever and trunnions being made of but one piece of fine wrought steel, the common defect of loose trunnions is avoided. Strength is obtained with much less weight of metal, and by the perfect bearing, which the solid trunnion gives, together with the use of perfected contact points, sticking is absolutely prevented.

The size and proportions are such as to make it the most perfect operating key possible to obtain, either for the hand of the skilled and rapid expert or the beginner.

List No.		List Price Each
530	Leg key with perfected contact points . . . . .	\$2.48
531	Legless key with perfected contact points . . . . .	2.26
6208	Portable base only, for legless keys . . . . .	1.50

For full nickel plated keys add 76 cents to above list.

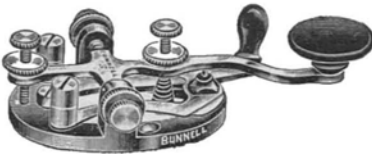

No. 6209



No. 6215

### The Triumph Key

This new model legless form of steel lever key has been adopted as the standard of the Western Union and Postal Telegraph & Cable Co.

In addition to the well-known superior points of our standard steel lever keys it has mica insulations, lips for "Bug" wedge and other valuable improvements which make it the acme of perfection in steel lever keys.

List No.		List Price Each
6209	Triumph key with perfected contacts . . . . .	\$3.38

### The Fry Open Circuit Key

Ideal for open circuit working with dry battery.

Has circuit-closer which must be worked like an ordinary key.

With circuit-closer in "closed" position, the battery cannot be put to line or short circuited by pressing down on key lever, hence leaving a book or other heavy object on key does not waste the battery, but the relay is always in circuit ready to receive signals.

List No.		List Price Each
6215	.....	\$5.40

## TELEGRAPH APPARATUS Sounders

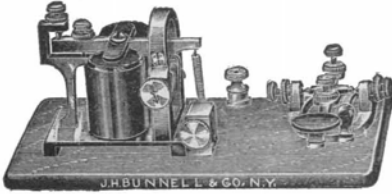

No. 559

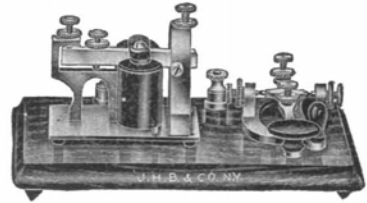

No. 504

### New Main Line Sounders

#### "MCM" MODEL

New and important improvements, instantaneous adjustment of both armature spring and distance from magnet cores, both adjustment nuts conveniently located in front. The arrow on the upper adjusting nut indicates the relative distance between armature and magnet cores, the string arrangement used in the old-style tension springs is entirely dispensed with, and a wide and rapid range of spring adjustment obtained by a cam lever operated by the lower adjusting nut. The MCM model retains all the good points of our original type of instrument, and is intended for use on main lines in place of the ordinary relay, and dispensing entirely with the local sounder, thus saving the continual expense of maintaining local batteries.

List No.		List Price Each
559	150 ohms, with key on base . . . . .	\$12.38
560	150 ohms, without key . . . . .	9.92
561	Mahogany case for wrecking sets . . . . .	4.96
562	Leather case . . . . .	16.50
563	250 ohms, with key on base . . . . .	13.22
564	250 ohms, without key . . . . .	10.74
565	20 to 100 ohms, with key on base . . . . .	11.94
566	20 to 100 ohms, without key . . . . .	9.46

Nos. 563 to 566 are for all circuits from 1 to 100 miles in length, when, with ordinary main battery power suitable for such lines, they are equal to the best local sounders.

### Standard Giant Sounder and Steel Lever Key COMBINATION SET

For learner's use, or for use on city wires, private lines, and all short lines up to 15 miles in length. This instrument consists of the latest form of Giant Sounder, finely finished, with aluminum lever, polished rubber covered magnets wound with fine silk covered wire, and mounted on polished mahogany base, with a steel lever, solid trunnion key, with guaranteed hardened platinum points. These instruments are the same high grade type that are, now, and have been for over a quarter of a century, the standard of the Western Union Telegraph Co., the Postal Telegraph Cable Co., and all the principal railroad telegraph companies in the United States, and are improved up to date.

List No.		List Price Each
504	Wound to 20 ohms resistance. For all short lines up to 15 miles. No relay required. . . .	\$6.08
505	Wound up to 4 ohms resistance. For local battery . . . . .	5.78
506	No. 505, complete with 6 x 8 crowfoot battery and chemicals, wire for connecting, and book of instructions, making an extra fine learner's set. . . . .	8.26

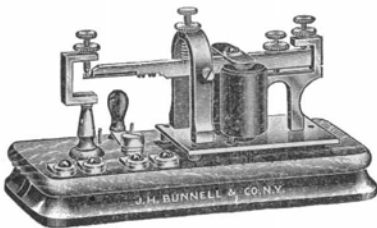

No. 514

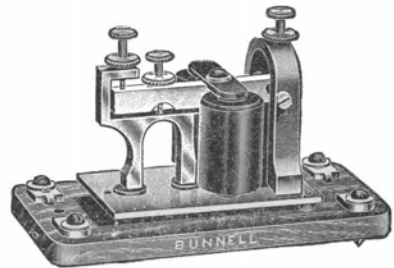

No. 507

### Repeating Sounders

List No.		List Price Each
514	The standard repeating sounder . . . . .	\$9.92
507	"Quad" repeating sounder, Giant pattern, with rigid points . . . . .	6.00

## TELEGRAPH APPARATUS Sounders

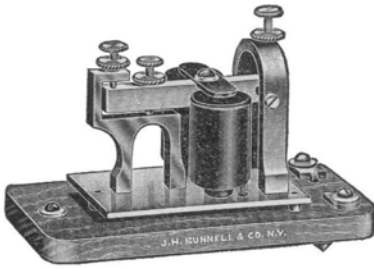

No. 500

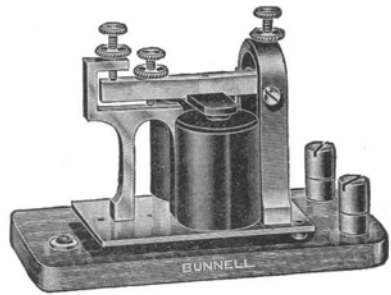

No. 515

### The New Aluminum Lever Giant Sounder

For use where tone, loudness and quick action are desired.

List No.		List Price Each
500	Original Giant sounder, wound to 4 ohms. Requires half the amount of local battery than any other forms of sounders.....	\$3.30
501	Wound with fine wire to 20 ohms resistance, for main line use (without relay) on lines up to 15 miles in length.....	3.60

Old style sounders, with brass levers, furnished at the same price.  
For nickel plated sounders add \$1 to list.

### The "1892" Giant Sounder

With Large Magnets and Important New Improvements

These sounders have aluminum or brass levers, and with one cell of local crowfoot battery will give a loud, clear and quick stroke.

List No.		List Price Each
515	Wound to 4 ohms resistance.....	\$4.96
516	Wound to 20 ohms resistance.....	5.26

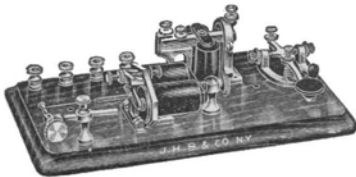

No. 579

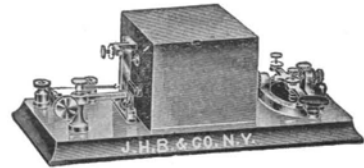

No. 542

### Relay, Steel Lever Key and Giant Sounder Combination Set

A complete set of our best instruments, mounted on polished mahogany base, occupying a space 13 inches long by 6 $\frac{3}{8}$  inches wide. For special office sets, and for use as testing sets at the switchboard.

List No.		List Price Each
579	Wound to 150 ohms.....	\$17.34
6225	Wound to 250 ohms.....	18.16

For nickel plating Fig. 579 or 6225 add \$3.30 to list.

580	With large relay, wound to 250 ohms.....	23.42
-----	--	-------

For nickel plating number 580 add \$4.14 to list.

### Box Sounding Relay and Steel Lever Key Combination Set

Of Best Construction for Loud, Clear Sound, Without Local Sounder, Polished Mahogany Box and Base

List No.		List Price Each
542	With steel lever key on base, wound to 150 ohms with silk covered wire.....	\$12.38
543	As above, wound 250 ohms.....	13.22
545	Without key, wound for 150 ohms resistance.....	9.92
546	Without key, wound for 250 ohms resistance.....	10.74

TELEGRAPH APPARATUS

Relays

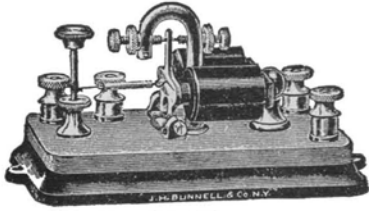

No. 567

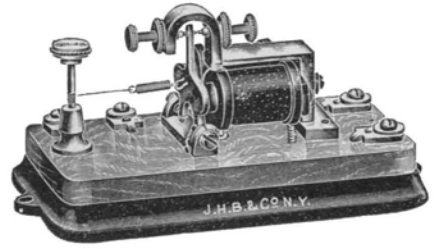

No. 570

The Dandy Pony Relay

List No.		List Price Each
567	20 ohms, non-adjustable rubber covered magnets . . . . .	\$4.50
568	20 ohms, non-adjustable cloth covered magnets . . . . .	4.06
569	20 ohms, adjustable rubber covered magnets . . . . .	4.96

Novel Form Pony Relay

For lines of less than 75 miles in length. Elegantly finished. Mounted on polished mahogany base, with ornamental surbase. Size of base, 6½ x 3½ inches.

570	20 ohms resistance or under, for lines up to 15 miles in length . . . . .	\$3.76
571	50 ohms resistance, for lines 20 to 40 miles long . . . . .	4.14
572	75 ohms resistance . . . . .	4.50
573	100 ohms resistance, for lines of 75 miles . . . . .	4.88
574	With polished rubber magnets, extra . . . . .	.50

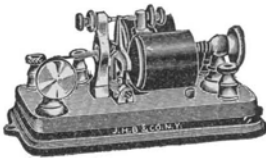

No. 575

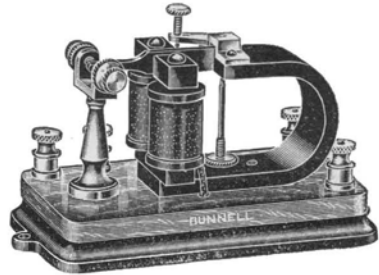

No. 555

The "1900" Model Pony Relay

An improved form of Pony Relay, with rubber covered, adjustable magnets, etc. Finely finished.

List No.	List Price Each	List No.	List Price Each
575	Wound to 20 or 30 ohms . . . . . \$6.38	577	Wound to 75 ohms . . . . . \$7.14
576	Wound to 50 ohms . . . . . 6.76	578	Wound to 100 ohms . . . . . 7.50

Standard Polarized Relays

555	Polarized relay No. 1, 20 ohms . . . \$11.26	556	Polarized relay No. 1, 50 ohms . . . \$11.64
-----	--	-----	--

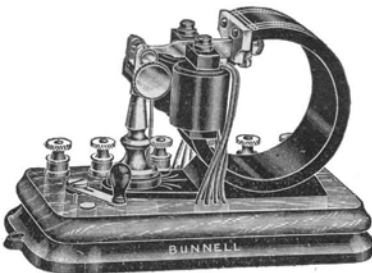

No. 554

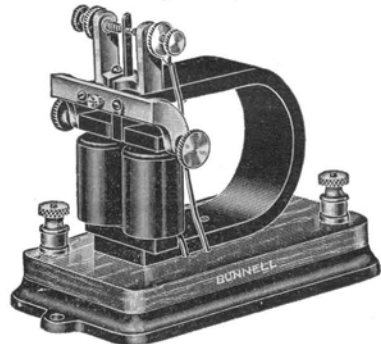

No. 557

Standard Polarized Relays

554	Differentially wound, 400 ohms . . . . .	\$29.26
557	Polarized relay No. 2, 50 ohms . . . . .	15.00
558	Polarized relay No. 2, 100 ohms . . . . .	15.38

The improved form of clamping binding posts are used on all instruments.

## TELEGRAPH APPARATUS Relays

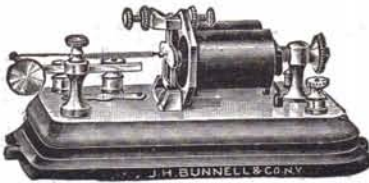

No. 533

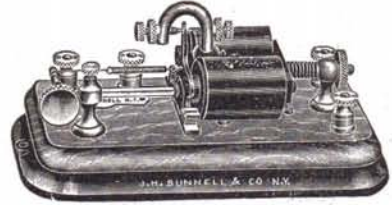

No. 536

### Main Line Relays

These relays are wound with silk covered wire, have polished rubber covered coils, mahogany base, extension adjustment and are mounted on ornamental subbases. The armature and lever are made from a single piece of malleable iron.

List No.		List Price Each
533	Standard No. 1 main line relay, 150 ohms . . . . .	\$9.00
534	Standard No. 1 main line relay, 250 ohms . . . . .	9.76
535	Standard No. 1 main line relay, 300 ohms . . . . .	10.50
536	Standard No. 2 main line relay, 150 ohms . . . . .	7.88
537	Standard No. 2 main line relay, 250 ohms . . . . .	8.64
538	Standard No. 2 main line relay, 300 ohms . . . . .	9.38

The standard No. 2 main line relay has been adopted by the Western Union and Postal Telegraph Companies.

For nickel plated relays add \$1.50 to list.

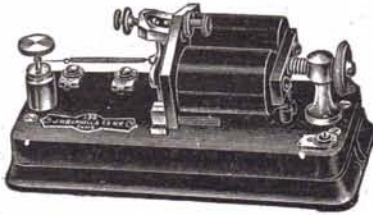

No. 768

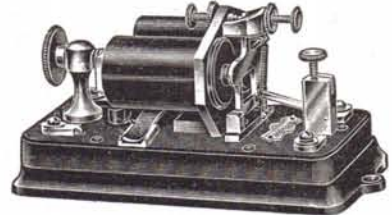

No. 770

### C.Q.A. Relay

With our new magnet adjustment the magnets may be instantly moved to any desired distance from the armature. The armature tension spring adjustment is also simplified and improved. The dimensions of subbase are only 7½ inches long by 3½ inches wide. The C. Q. A. relay is mounted on slate instead of wood. It is furnished with the latest style of W. U. clamp connections to which the magnet and local wires are soldered, thus making such a thing as a loose connection impossible. The magnets are supported and protected by a spectacle frame. An automatic stop prevents contact between the magnet cores and the armature.

The C. Q. A. relay will be furnished regularly with hardened silver contact points as adopted by the Western Union and Postal Telegraph Companies.

List No.		List Price Each
768	Wound to 150 ohms resistance . . . . .	\$2.88
769	Wound to 250 ohms resistance . . . . .	8.64

### S.O.S. Relay

The illustration shows our latest compact form of C. Q. A. relay, known as the S. O. S. type. It is mounted on slate base 5¾ x 3 inches with a "dead" local post, to facilitate resonator connection and with a miniature jack underneath the magnet spools for vibrating transmitter (bug) connection. It has a novel stringless, tension spring adjustment that avoids spoiling the springs by putting them out of shape. We can furnish the S. O. S. relay with or without the bug jack. Mounted on subbase or feet as desired.

List No.		List Price Each
770	150 ohms resistance, with jack . . . . .	\$10.14
771	150 ohms resistance, without jack . . . . .	9.46
772	250 ohms resistance, with jack . . . . .	10.88
773	250 ohms resistance, without jack . . . . .	10.22

## TELEGRAPH APPARATUS Learner's Outfits

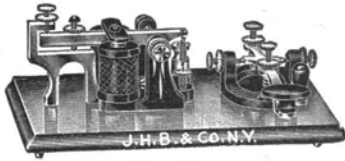

No. 607

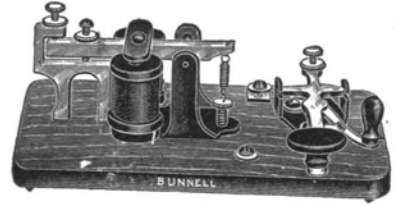

No. 436

### The "Dandy" Morse Learner's Outfit

Consists of a full size, well made, complete Morse telegraph apparatus of the latest and best form for learners, including handsome sounder, with steel lever (solid trunnion) key, and a cell of gravity battery, latest form. It is the best working set of learner's instruments for short or long lines. The sounder lever, sounder yoke, adjustment screws, etc., are in finely finished brass composition, the same metal as in all our first class instruments. The magnets are strong. The sounder is loud and clear.

List No.	List Price Each	
605	Complete outfit consists of one No. 607 "Dandy" learner's instrument, with 5 x 7 crowfoot battery, wire, book of instructions, and all necessary material for operating. . . . .	\$4.96
606	Same as No. 605 but with dry cell instead of crowfoot battery. . . . .	3.50
607	"Dandy" Morse instrument only, wound to 4 ohms. . . . .	3.00
608	"Dandy" Morse instrument only, wound to 20 ohms. . . . .	3.30
609	Cell of 5 x 7 crowfoot battery complete (no chemicals). . . . .	1.50
610	Cell of Mascot dry battery. . . . .	.54

### The "New Departure" Learner's Outfit

The ideal set for home practice. Always ready, neat, clean and attractive. The instrument is a well made Beeko learner's apparatus, with a steel lever key, arranged for use with a Mascot dry battery. The circuit closer is detached from the key, as it will prolong the life of the battery to leave the circuit open when not using the instrument. With circuit closer detached the Mascot battery should last for several months' practice. It is sent with each apparatus so that it can be replaced when it is desired to operate two or more instruments on the same circuit with bluestone battery. The magnets can be rewound at slight expense for use on longer, outdoor lines. Instruction book sent free with each outfit. Manual of telegraphy sent free on application. This outfit, packed in wooden box, weighs 7 pounds.

List No.	List Price Each	
611	Complete outfit consisting of one No. 436 Beeko learner's instrument, with cell of mascot dry battery, wire and book of instructions. . . . .	\$3.00
436	Beeko instrument only, wound to 4 ohms. . . . .	2.48
437	Beeko instrument only, wound to 20 ohms. . . . .	2.78

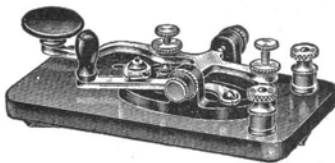

No. 775

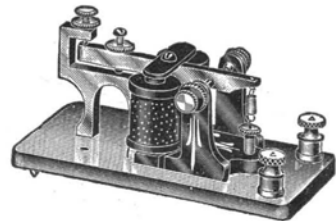

No. 776

### "Dandy" Learner's Key and Sounder

The "Dandy" is our higher grade learner's set, and is superior to any other learner's set on the market. These keys and sounders are the same as those furnished with our regular sets, but are mounted on separate bases.

List No.	List Price Each	
775	Dandy key. . . . .	\$1.50
	Postage weight 1 lb.	
776	Dandy sounder, 4 ohms. . . . .	\$1.96
777	Dandy sounder, 20 ohms. . . . .	2.26
	Postage weight 2 lbs.	

## TELEGRAPH APPARATUS

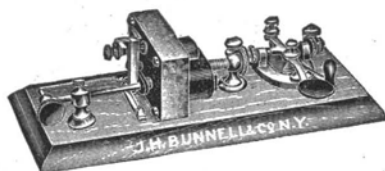

Barclay Box Relay

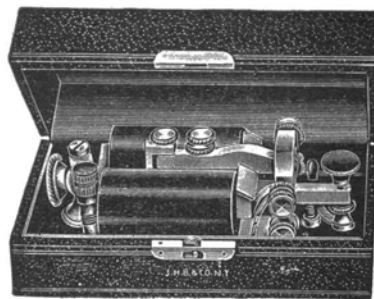

No. 581

## Barclay Box Relays

The snare drum principle produces a clear, pleasing sound that is very penetrating, consequently can be easily read even in noisy places or on lines having weak currents.

List No.	Description	List Price Each
404	150 ohms, with key and local contacts . . . . .	\$14.86
405	150 ohms, with key, without local contacts . . . . .	13.62
426	150 ohms, without key, with local contacts . . . . .	12.38
427	150 ohms, without key or local contacts . . . . .	11.14

For 250 ohms, add 76 cents to above list.

## Pocket Relays

Has all the practical qualities of a full size sounding relay and is a very compact and handsome instrument.

Furnished with nicely finished carrying case 5¾ inches long, 2¾ inches deep, 2½ inches wide.

581	Wound to 150 ohms, with case . . . . .	\$22.50
6226	Wound to 250 ohms, with case . . . . .	23.26

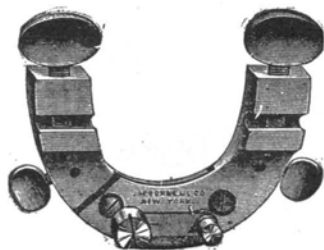

No. 2280

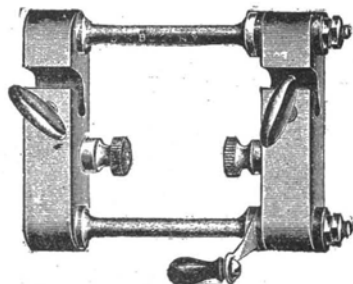

No. 2282

## Line Tapping Clamp

The line tapping clamp is for use in establishing a temporary office anywhere on the line. The line wire is clamped tightly in the upper clamps and then cut, and the operating instrument attached by two pieces of wire to the two lower clamps. The clamp is provided with a circuit closer, and may be left in the line after using until the line repairer can take it out and join the line.

List No.	Description	List Price Each
2280	Brass . . . . .	\$6.00
2281	Steel . . . . .	6.00
2282	No. 2 oblong pattern . . . . .	7.50

## Standard Rheostat

Improved solid top, with coils carefully and accurately adjusted.

List No.	Description	List Price Each
1247	Capacity ½ to 10000 ohms . . . . .	\$67.50
1248	Capacity 1 to 10000 ohms . . . . .	67.50
1250	Capacity ½ to 2000 ohms . . . . .	60.00
1251	Capacity 1 to 2000 ohms . . . . .	60.00
7551	Quadruplex rheostat . . . . .	75.00
7552	Proportional quadruplex rheostat . . . . .	33.76
7554	Smith rheostat . . . . .	18.00
7553	Standard duplex rheostat . . . . .	30.00

**TELEGRAPH APPARATUS  
Pole Changing Transmitters**

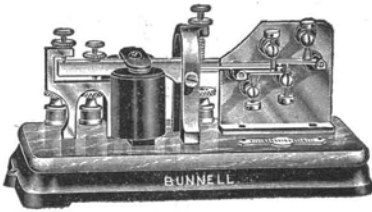

No. 599

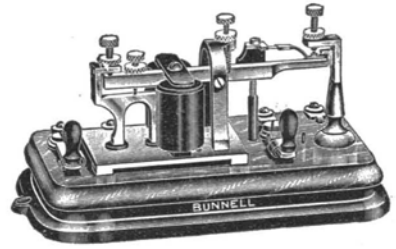

No. 592

**B. & O. Pattern**

Battery pole changing transmitter with adjustable springs bearing upon the contact levers.

List No.		List Price Each
599	For duplex and quadruplex work.....	\$22.50

**Milliken-Hicks Repeater Transmitter**

592.....		\$14.18
----------	--	---------

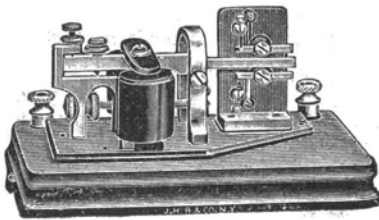

No. 600

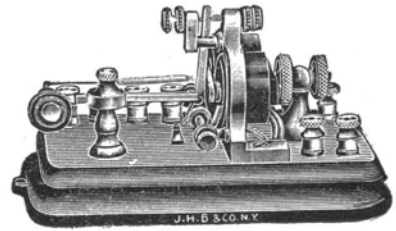

No. 601

**Battery Pole Changer**

List No.		List Price Each
600	For duplex and quadruplex work..... This is the new Western Union type of instrument.	\$22.50

**Smith Neutral Relay**

601	Three coil, for quadruplex circuits.....	\$20.26
-----	--	---------

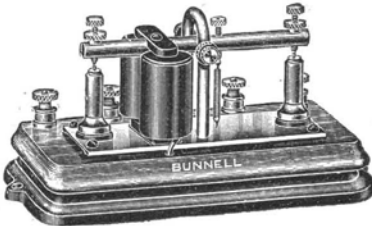

No. 603

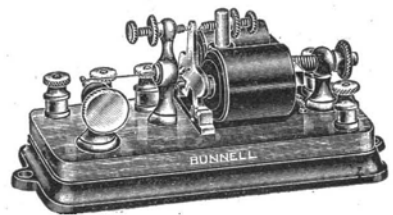

No. 604

**Standard Dynamo Pole Changer**

List No.		List Price Each
603	For duplex and quadruplex circuits.....	\$12.38

**Penn. R. R. Model**

604	30 ohms or under, for duplex and quadruplex circuits.....	\$9.46
-----	---	--------

## TELEGRAPH APPARATUS Switchboards

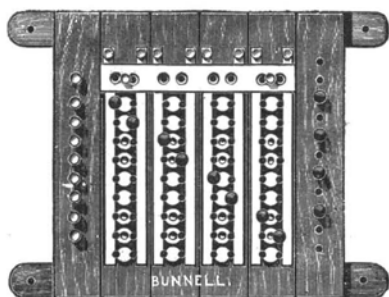

Western Union Button Switch

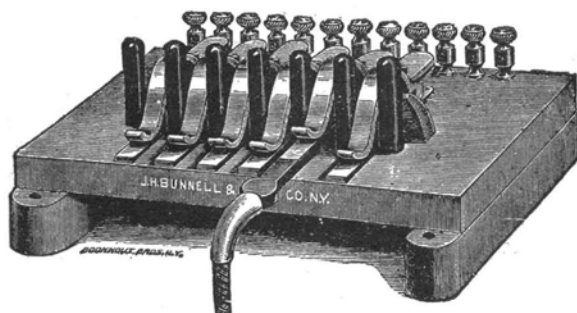

No. 1268 Spring Jack

### Western Union Button Switch, with Plate Lightning Arrester

List No.	Line	Perpendicular Bars	List Price Each
1236	1	2	\$3.48
1237	2	4	6.94
1238	3	6	9.92
1239	4	8	14.86
1240	5	10	19.80
1241	6	12	23.80
1725	7	14	29.72
1726	8	16	37.14
1727	10	20	49.50
1728	12	24	67.50
1729	Extra pins		.22

In ordering switches for large offices, give full particulars as to number and changes of wires, loops, batteries and instruments to be provided for. For larger sizes, special prices furnished upon application.

### Western Union Spring Jack, with Wedge and Cord

List No.		List Price Each
1268	Per line (state number of jacks required in ordering)	\$4.50
1269	Wedge, with 4 ft. cord, extra	3.00
1270	Cord, heavy, flexible, two conductor silk, per yard	1.00

In ordering or requesting prices on spring jack switchboards state the number of lines for which they are wanted, how many horizontal rows of discs, and whether a single or double row of jacks is required. Prices on spring jack switchboards, lampboards and terminal boards, furnished on application, accompanied with particulars of requirements.

### Bunnell Pattern Button Switch

Single pin cut-out and other important improvements

List No.	Line	Perpendicular Bars	List Price Each
1223	1	2	\$4.06
1224	2	4	8.10
1225	3	6	12.38
1226	4	8	18.76
1227	5	10	24.76
1228	6	12	30.00
1229	7	14	37.50
1230	8	16	47.26
1231	10	20	67.50
1232	12	24	90.00
1233	Extra switch pins		.22

In ordering switches for large offices, give full particulars as to number and changes of wires, loops, batteries and instruments to be provided for.

### Loop Peg and Cord

Split peg or pin for use with Western Union Button switch to loop in an instrument.

List No.		List Price Each
1234	Loop peg, without cord	\$1.50
1235	Loop peg, with three-foot cord	3.46

TELEGRAPH APPARATUS

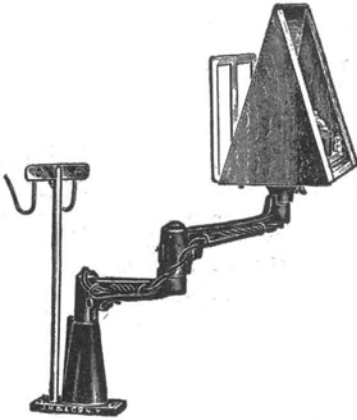

No. 7971

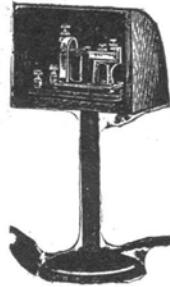

No. 619

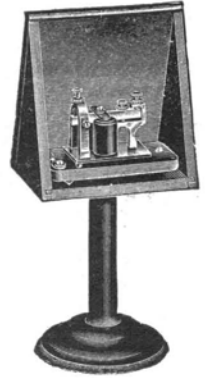

No. 7972

**Acme Adjustable Resonator**

(Western Union Standard E. M. 33A.)

With double swing arm and swivelled hood.

The stand and arms are of iron finished in black japan, the hood of finely finished resonant wood; the message stand and rack are brass finished in gold lacquer, making a very handsome and attractive combination.

The height of the hook stand is 10½ inches, arm spread 15½ inches.

Made in three styles, as follows: Without message rack or stand; with message rack on wood, without stand; with message rack and stand, as shown in illustration.

List No.	(Prices do not include Sounder.)	List Price Each
7969	Without message rack or stand.....	\$10.14
7970	With message rack without stand.....	11.26
7971	With message rack and stand.....	13.50

**Mascot Resonator**

Portable, can be moved to any desired position within range of cord. The cord enters base and passes through hollow stem to sounder.

619	Without sounder.....	\$3.38
-----	----------------------	--------

**Acme Portable Resonator**

(Western Union Standard E. M. 5A.)

A very popular and efficient type.

Furnished with or without message rack on back of hood.

Price does not include sounder.

7972	Without message rack.....	\$4.50
7973	With message rack.....	5.64

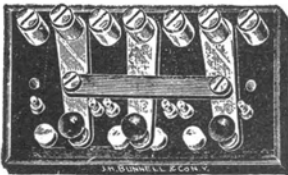

No. 1322

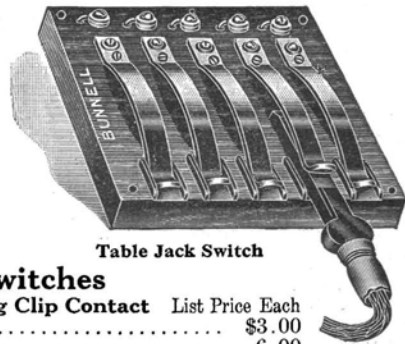

Table Jack Switch

**Quadruplex Switches**

Rubber Base with Spring Clip Contact

List No.	List Price Each
8602	Single 3 point..... \$3.00
1321	Double 3. point..... 6.00

**Quadruplex Switches, Slate Base**

List No.	List Price Each
8528	3 point, 1 lever..... \$1.80
8529	6 point, 2 lever..... 3.38
1322	7 point, 3 lever..... 4.06

**Table Jack Switches**

List No.	List Price Each
633	For switching resonator set of instruments to any desired line. 3 line table jack..... \$4.14
634	Over 3 lines, per line..... 1.24
635	Wedge with 4 foot cord, extra..... 3.00

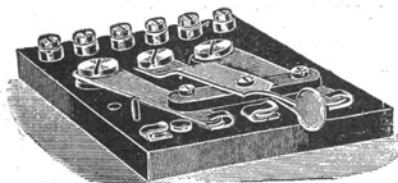

No. 1321

Telephone Apparatus and Supplies

# Western Electric

## GALVANIZED POLE LINE HARDWARE

Line trouble during storms is not caused by the failure of the strongest nor even of the average pin or support. It is the weakest support that causes the damage. You can have no feeling of security, therefore, when your supports are made from a material which, while having the necessary average strength, varies greatly in the strength of the weakest and strongest pieces.

### Open Hearth Steel

Western Electric pole line hardware is made from open hearth steel having a tensile strength of from 55,000 to 65,000 pounds per square inch, while ordinary iron runs as low as 35,000 pounds per square inch, while the best grades of malleable iron run still lower. It has the further advantage of being uniform in strength and every piece equally dependable.

Open hearth steel can be bent cold to 180 degrees flat upon itself without fracture on the outside of the bent portion. Common iron, or Bessemer steel may in one case meet this bending test and the next time break in a slight bend, while malleable iron of ordinary commercial grade breaks largely at less than 15 degrees deflection.

### Galvanizing

There has been much misunderstanding in the past regarding the subject of galvanizing.

There are three processes of so-called galvanizing—the Hot Dip Process, the Cold or Electro Process and the Sherardizing Process. These three processes are exactly alike in the original preparation, that is, the articles must be cleaned of all surface scale, rust and other foreign matter. This is done by pickling the article in a weak solution of sulphuric acid, or they may be cleaned by tumbling or sand blasting. From this point, however, the processes differ:

**ELECTRO-GALVANIZING** This is merely an electric plating process using zinc anodes. A low voltage electric current is used and the zinc is deposited in minute particles. The length of time for a coating of zinc of a given thickness depends upon the voltage; the higher voltage, of course, requiring less time, but this increase in voltage deposits the zinc in larger particles and therefore the higher the voltage is run the more granular and porous will be the coating. This process is commercially impracticable, as it requires a considerable length of time to deposit a coating which will withstand the standard test.

**SHERARDIZING** In this process the articles to be coated are placed in an airtight metal drum and the remaining space filled with zinc dust containing from 40 to 80 per cent. of metallic zinc. This drum is then brought up to a temperature from 100 to 200 degrees below the melting point of zinc and kept at this temperature a predetermined length of time. At the expiration of this period the drum is allowed to cool slowly until the articles have reached a temperature of perhaps 300 to 400 degrees.

The weak point in this process is the variability of the result and to the fact that no accelerated test has been developed which positively proves the weather resisting character of the zinc coating. One sherardized article may have a coating which resists the action of the weather indefinitely, while another piece from the same lot may break down within a few days.

**HOT GALVANIZING** In the hot galvanizing process the articles after being cleaned are treated with a muriatic acid flux and then dipped in molten zinc. The articles are allowed to remain until they have reached the same temperature as the molten zinc. They are then withdrawn, again treated with the flux and reimmersed in the molten metal.

The result of this process is a smooth non-porous covering of pure zinc which adheres closely to the surface, effectually sealing all riveted joints, etc., and positively excluding moisture during the life of the coating.

This process of double hot dip galvanizing is used on all Western Electric line hardware and is guaranteed to meet the standard four-immersion test and will actually withstand five or six immersions before breaking down. This test is equal to from 35 to 40 years of actual service under ordinary atmospheric conditions.

Western Electric galvanized line hardware has no variable factor. If ten articles out of a lot of 10,000 pieces pass the required test, it is fair to assume the entire lot would pass the same test, especially in view of the surface inspection, which eliminates any pieces on which bare spots have been produced by improper cleaning.

Western Electric pole line hardware is the best obtainable and must pass the most rigid inspections of both raw material and the finished product before it is accepted into our warehouse stocks.

Our stocks are large and orders for shipment either from our distributing warehouses or from the factory will receive immediate attention.

## WOOD POLES

### Poles

The Western Electric Company is noted for the quality of the poles it handles and the service it renders. Our facilities for securing stock, our large and numerous concentrating yards, make it possible for us to meet any demand at a moment's notice. Our record has given us an enviable reputation in the pole business throughout the United States and Canada.

In order to give our friends and patrons a more intimate knowledge of what we can supply in the way of poles and pole-line material, we have assembled in these pages a representative list of the standard stocks carried by us.

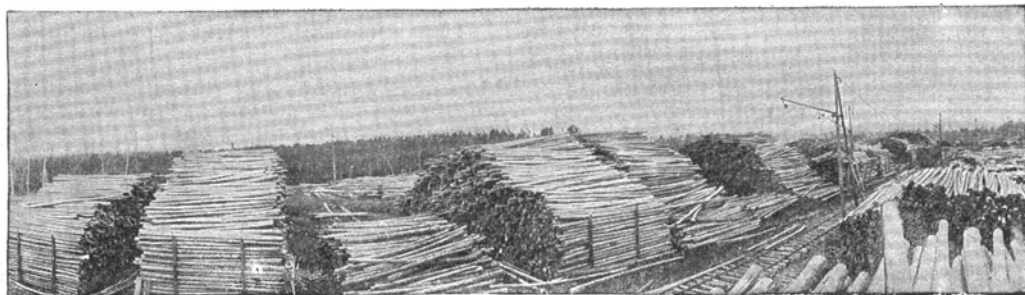

Section of One of Our Many Pole Yards

### Large Posts and Small Poles

#### Northern White Cedar Association Specification

"Sizes 4 inch 10 foot to 4 inch 18 foot inclusive. Sizes at top may be  $\frac{1}{4}$  inch less than the diameter specified. Four inch 20 foot poles circumference measurement at top end 12 inches for seasoned stock and  $12\frac{1}{2}$  inches for green or water soaked stock, 5 inch top and larger 20 foot poles take same circumference top measurement as longer poles of same size. Lengths may be two inches scant. On posts and poles 10, 12, 14, 16 feet long, 4 inch crook one way allowed. Eighteen and 20 foot poles, 4 inch crook one way allowed, the sweep to be measured from a point 4 feet from the butt. Pipe holes in top allowed. Must be cut from live timber and in other respects, except as above mentioned, conform to post specifications. Green, fresh cut or water soaked stock must be plump measure for the diameter or circumference specified."

### Standard Telegraph, Telephone and Electric Poles

#### Northern White Cedar Association Specification

"Sizes 4 inch 25 feet and upwards. Above poles must be cut from live growing timber, peeled and reasonably well proportioned for their length. Tops must be reasonably sound, must measure in circumference as follows: seasoned 4 inch poles, 12 inches; 5 inch poles, 15 inches; 6 inch poles,  $18\frac{1}{2}$  inches; 7 inch poles, 22 inches. If poles are green, fresh cut or water soaked, then 4 inch poles must measure  $12\frac{1}{2}$  inches; 5 inch poles, 16 inches; 6 inch poles,  $19\frac{1}{2}$  inches; 7 inch poles,  $22\frac{3}{4}$  inches in circumference at top end. Lengths may be  $\frac{1}{2}$  inch scant for each 5 feet in length and 6 inches long for any length from 20 feet up.

"One way sweep allowable not exceeding 1 inch for every 5 feet, for example, in a 25 foot pole, sweep not to exceed 5 inches, and in a 40 foot pole, 8 inches. Measurement for sweep shall be taken as follows: That part of the pole when in the ground (6 feet) not being taken into account in arriving at sweep, tightly stretch a tape line on the side of the pole where the sweep is greatest, from a point 6 feet from the butt to the upper surface at top, and having so done measure widest point from tape to surface of pole and if, for illustration, upon a 25 foot pole said widest point does not exceed 5 inches, said pole comes within the meaning of these specifications. Butt rot in the center including small ring rot outside of the center; total rot must not exceed 10 per cent. of the area of the butt. Butt rot of a character which plainly seriously impairs the strength of the pole above ground is a defect. Wind twist is not a defect unless very unsightly and exaggerated. Rough, large knots if sound and trimmed smooth are not a defect."

## WOOD POLES

### Western or Idaho Cedar Poles

#### Western Red Cedar Association Specifications

"All poles must be cut from live, growing cedar timber, peeled, knots trimmed close, butts and tops sawed square, tops must be sound and must measure as follows in circumference:

4 in. top, 12 in. circ.	7 in. top, 22 in. circ.	9 in. top, 28 in. circ.
5 in. top, 15 in. circ.	8 in. top, 25 in. circ.	10 in. top, 31 in. circ.
6 in. top, 18½ in. circ.		

"No pole shall have more than one crook and this shall be one way only, the sweep not to exceed 1 inch to every 6 feet in length. Same to be determined in the following manner: Measurement for sweep shall be taken as follows: That part of the pole when in the ground (6 feet) not being taken into account in arriving at sweep, tightly stretch a tape line on the side of the pole where sweep is greatest, from a point 6 feet from butt to the upper surface at top, and having so done measure widest point from tape to surface of pole and if, for illustration, upon a 30-foot pole said widest point does not exceed 5 inches, said pole comes within the meaning of these specifications.

"Butt rot in center, including small ring rot, shall not exceed 10 per cent. of the area of the butt. Butt rot of a character which impairs the strength of the pole above ground is a defect.

"Large knots, if sound and trimmed smooth, are not a defect.

"A perfectly sound, dead or dry streak shall not be considered a defect when it does not materially impair the strength of the pole."

List No.	Diameter Top Inches	Length Feet	Estimated Wt. Lbs.	List No.	Diameter Top Inches	Length Feet	Estimated Wt. Lbs.
741054	4	20	100	Following sizes require two cars for shipping.			
741055	5	20	135	740051	7	45	850
741056	6	20	190	740052	8	45	1000
741062	7	20	260	740053	9	45	1200
741063	8	20	325	741061	7	50	1050
741057	4	25	150	740054	8	50	1200
741058	5	25	200	740055	9	50	1400
740040	6	25	250	740056	8	55	1400
740041	7	25	325	740057	9	55	1600
740042	8	25	400	740058	8	60	1600
740043	6	30	350	740059	9	60	1850
740044	7	30	400	740060	8	65	1850
740045	8	30	500	740061	9	65	2200
741059	6	35	450	741066	8	70	2200
740046	7	35	500	741067	9	70	2600
740047	8	35	625	741069	8	75	2600
741060	9	35	800	741070	9	75	3000
741064	6	40	600	741072	8	80	3000
740048	7	40	650	741786	9	85	3500
740049	8	40	800	741073	8	80	3500
740050	9	40	1000	741787	8	90	4500

## Chestnut Poles

#### A. T. & T. and Western Union Specifications

"All poles shall be of sound, live white chestnut, squared at both ends, reasonably straight, well proportioned, from butt to top, peeled and knots trimmed to the surface of the pole."

List No.	Class	Length Feet	Circum. Top Inches	Circum. 6 Feet From Butt Inches	Weight	List No.	Class	Length Feet	Circum. Top Inches	Circum. 6 Feet From Butt Inches	Weight
741074	D	20	20	24	400	741093	D	45	20	43	2000
741075	C	20	20	27	500	741094	C	45	20	43	2000
741076	B	20	22	31	600	741095	B	45	22	47	2200
741077	D	25	20	27	500	741096	A	45	24	48	2500
741078	C	25	20	30	600	741097	D	50	20	46	2400
741079	B	25	22	33	700	741098	C	50	20	46	2400
741080	A	25	24	36	1000	741099	B	50	22	50	2700
741081	D	30	20	31	900	741100	A	50	24	51	3000
741082	C	30	20	33	1000	741101	C	55	20	49	3100
741083	B	30	22	36	1100	741102	B	55	22	53	3300
741084	A	30	24	40	1350	741103	A	55	22	54	3300
741085	D	35	20	35	1200	741104	B	60	22	56	3900
741086	C	35	20	36	1250	741105	A	60	22	57	3900
741087	B	35	22	40	1400	741106	B	65	22	59	4500
741088	A	35	24	43	1700	741107	A	65	22	60	4500
741089	D	40	20	39	1600	741108	B	70	22	62	5100
741090	C	40	20	40	1600	741109	A	70	22	63	5100
741091	B	40	22	43	1800	741110	B	75	22	65	5900
741092	A	40	24	45	2000	741111	A	75	22	66	5900

NOTE: The above specifications provide a stocky, high grade pole. We can also furnish chestnut poles under top dimension specification only.

Prices on application.

## WOOD POLES

## Northern White Cedar Poles

## Northern White Cedar Association Specifications

List No.	Diameter Top Inches	Length Feet	Weight Lbs.	No. to Carload		List No.	Diameter Top Inches	Length Feet	Weight Lbs.	No. to Carload	
				From	To					From	To
740001	4	16	85	340	400	740995	5	35	400	75	100
740002	5	16	105	300	400	741531	5½	35	400	75	100
740987	6	16	135	230	300	740017	6	35	450	75	100
740003	4	18	95	325	400	740996	6½	35	450	60	80
740004	5	18	125	250	300	740018	7	35	600	50	75
740005	6	18	155	200	250	740997	8	35	850	40	60
740006	4	20	100	300	400	740019	6	40	625	50	75
740007	5	20	130	230	300	740998	6½	40	625	45	60
740988	5½	20	130	230	300	740020	7	40	850	40	60
740008	6	20	190	150	225	740999	8	40	1100	30	45
740989	5	22	175	175	250	Following sizes require two cars for shipping.					
740009	4	25	150	200	250	741000	6	45	900	60	80
740010	5	25	200	150	225	741001	7	45	1100	50	70
740011	5½	25	200	135	190	741002	8	45	1350	45	60
740012	6	25	250	125	150	741003	6	50	1150	50	70
740990	6½	25	250	100	130	741004	7	50	1350	45	60
740013	7	25	350	90	125	741005	8	50	1700	35	45
740991	8	25	425	90	125	741781	6	55	1400	40	50
740014	5	30	275	110	175	741006	7	55	1700	35	45
740992	5½	30	275	100	130	741007	8	55	2200	25	35
740015	6	30	350	90	125	741008	7	60	2200	25	35
740993	6½	30	350	75	100	741009	8	60	2500	22	30
740016	7	30	450	75	100	741010	7	65	2500	22	30
740994	8	30	600	50	75	741011	8	65	3000	18	25

Prices on application.

## A. T. and T. Co., Western Union and Nat. Electric Light Association Specifications

List No.	Class	Length Feet	Circum. Top Inches	Circum. 6 Feet from Butt Inches	Weight Lbs.	List No.	Class	Length Feet	Circum. Top Inches	Circum. 6 Feet from Butt Inches	Weight Lbs.
741013	F	20	15½	....	130	741035	E	40	18¾	....	625
741014	D	20	17¼	....	130	741036	D	40	18¾	....	625
741015	C	20	18¾	27	190	741037	C	40	18¾	40	625
741016	E	22	15½	....	175	741038	B	40	22	43	850
741017	D	22	17¼	....	175	741039	A	40	24	47	1100
741018	C	22	18¾	28½	250	Following sizes require two cars for shipping.					
741019	B	22	22	30	275	741040	E	45	22	....	1100
741020	G	25	12½	....	150	741041	D	45	22	....	1100
741021	F	25	15½	....	200	741042	C	45	18¾	43	900
741022	E	25	17¼	....	200	741043	B	45	22	47	1100
741023	D	25	18¾	....	250	741044	A	45	24	50	1350
741024	C	25	18¾	30	250	741045	E	50	22	....	1350
741025	B	25	22	32	350	741046	D	50	22	....	1350
741026	A	25	24	36	425	741047	C	50	18¾	46	1150
741027	D	30	18¾	....	350	741048	B	50	22	50	1350
741028	C	30	18¾	33	350	741049	A	50	24	53	1700
741029	B	30	22	36	450	741050	B	55	22	53	1700
741030	A	30	24	40	600	741051	A	55	24	56	2200
741031	D	35	18¾	....	450	741052	B	60	22	56	2200
741032	C	35	18¾	36	450	741053	A	60	24	59	2500
741033	B	35	22	38	600						

Prices on application.

Telephone Apparatus and Supplies

## WOOD CROSSARMS Washington Fir or Yellow Pine



### Wood Crossarm STANDARD ARMS

**Size 3 1/4 x 4 1/4 ins. Bored for 1 1/2 in. Pins, or 1-5/8 in. Machine Bolt and 2-3/8 in. Brace Bolts**

Length Feet	Number of Pins	Standard Spacings			Brace	Washington Fir		Yellow Pine	
		Center	Side	End		List No.	Wt. Lbs. Each	List No.	Wt. Lbs. Each
3	2	28	..	4	25	740092	10.2	740112	13.8
4	4	16	12	4	28	740093	13.6	740113	18.4
5	4	18	17	4	28	740094	17	740114	23
6	4	22	21	4	32	740095	20.4	740115	27.6
6	6	16	12	4	32	740096	20.4	740116	27.6
8	6	18	17 1/2	4	32	740097	27.2	740117	36.8
8	8	16	12	4	32	740098	27.2	740118	36.8
8 1/2	10	16	9 3/4	4	32	741146	28.9	741148	39.1
10	10	17 1/2	15 3/4	4	42	740099	34	740119	46
10	10	16	12	4	42	740100	34	740120	46
10	12	16	9 3/8	3 3/8	42	741147	34	741149	46

### PONY TELEPHONE ARMS

**Size 2 3/4 x 3 3/4 ins. Bored for 1 1/4 in. Pins, 1-5/8 in. Machine Bolt and 2-3/8 in. Brace Bolts**

Length Inches	Number of Pins	Standard Spacings			Brace	Washington Fir		Yellow Pine	
		Center	Side	End		List No.	Wt. Lbs. Each	List No.	Wt. Lbs. Each
24	2	17	....	3 1/2	..	740101	5	740122	6.6
30	2	23	....	3 1/2	..	740102	6.2	740123	8.2
36	2	29	....	3 1/2	25	740103	7.5	740124	9.9
42	4	16	9 1/2	3 1/2	28	740104	8.7	740125	11.5
62	6	16	9 3/4	3 1/2	28	740106	12.9	740126	17
82	8	16	9 3/4	3 3/4	28	740108	17	740127	25.5
102	10	16	9 3/4	4	28	740110	21.2	740129	27.8
120	12	16	9 3/8	3 3/8	28	740111	25	740130	33

### N. E. L. A. ARMS

Standard Sizes Adopted by the National Electric Light Association

**Size 3 1/2 x 4 1/2 ins. Bored for 1 1/2 in. Pins, 1-5/8 in. Machine Bolt and 2-3/8 in. Brace Bolts**

Length Feet	Number of Pins	Standard Spacings			Brace	Washington Fir		Yellow Pine	
		Center	Side	End		List No.	Wt. Lbs. Each	List No.	Wt. Lbs. Each
3 ft. 2 ins.	2	30	....	4	32	740105	12.7	741120	16.9
5 ft. 7 ins.	4	30	14 1/2	4	38	740107	22.3	741121	29.8
8 ft.	6	30	14 1/2	4	38	740109	32	741122	42.8
9 ft. 2 ins.	8	30	12	4	38	741119	36.7	741123	49

### RAILROAD ARMS

**Size 3 x 4 1/4 ins. Bored for 1/2 in. Steel Pins, 1-5/8 in. Machine Bolt and 2-3/8 in. Brace Bolts**

Length Feet	Number of Pins	Standard Spacings			Brace	Washington Fir		Yellow Pine	
		Center	Side	End		List No.	Wt. Lbs. Each	List No.	Wt. Lbs. Each
6	4	22	21	4	32	741662	19.2	741127	24.6
6	6	16	12	4	32	741124	19.2	741128	24.6
8	6	18	17 1/2	4	32	740128	25.6	741129	32.8
8	8	16	12	4	32	741125	25.6	741130	32.8
10	8	17 1/2	15 3/4	4	42	741663	32	741131	41
10	10	16	12	4	42	741126	32	741132	41

### STANDARD POWER ARMS AND SPECIAL BORED ARMS

List No.	Size	Weight per Lineal Foot	List No.	Size	Weight per Lineal Foot
741133	3 1/4 x 4 1/4	3.4 lbs.	741140	3 3/4 x 5	4.7 lbs.
741134	3 x 4 1/4	3.2 lbs.	741141	3 3/4 x 5 3/4	5.4 lbs.
741135	2 3/4 x 3 3/4	2.5 lbs.	741142	4 x 5	5 lbs.
741136	3 1/2 x 4 1/2	4 lbs.	741143	4 x 6	6 lbs.
741137	3 1/2 x 4 3/4	4.2 lbs.	741144	4 3/4 x 5 3/4	6.7 lbs.
741138	3 1/2 x 5	4.4 lbs.	741145	5 x 6	7.3 lbs.
741139	3 3/4 x 4 3/4	4.5 lbs.			

Prices on application.

INSULATOR PINS AND BRACKETS



Oak Pin



Locust Pin

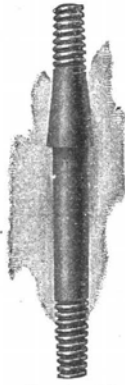

Duplex Pin



Duplex Bracket



Wood Bracket



Steel Pin

Wood Pins  
OAK

List No.	Size	Description	*List Price per 1000
740137	1 1/4 x 8 ins.	Standard Oak Pin.....	\$12.00
740136	1 1/2 x 9 ins.	Standard Oak Pin.....	16.00

LOCUST

740139	1 1/4 x 8 ins.	Standard Locust Pin.....	\$21.08
740140	1 1/4 x 9 ins.	Standard Locust Pin.....	28.00
741150	1 1/4 x 8 ins.	No. 2 grade Locust Pin.....	11.34
741151	1 1/2 x 8 ins.	Standard Locust Pin.....	28.00
741152	1 1/2 x 9 ins.	Standard Locust Pin.....	30.94
741153	1 1/2 x 9 ins.	No. 2 grade Locust Pin.....	16.80
741158	1 1/2 x 11 ins.	Standard Locust Pin.....	43.32

DUPLEX LOCUST

741154	1 1/4 x 12 ins.	Standard Duplex Locust Pin.....	\$39.34
--------	-----------------	---------------------------------	---------

TRANSPPOSITION LOCUST

741155	1 1/4 x 9 ins.	Standard Transposition Locust Pin.....	\$28.00
--------	----------------	--	---------

CORNER PIN LOCUST

741156	1 1/2 x 9 ins.	Locust Corner Pin, equipped with bolts, nuts and washers.....	\$122.50
--------	----------------	---	----------

DUPLEX BRACKETS

741157		Brown Duplex Locust Bracket.....	\$84.28
741158		Brown Duplex Oak Bracket.....	44.68
740153	1 1/2 x 2 x 13 ins.	Duplex Oak Bracket, painted or paraffined.....	42.00

WOOD BRACKETS

740151	1 1/2 x 2 x 10 ins.	Oak Bracket, painted or paraffined.....	\$22.54
740148	1 1/2 x 2 x 12 ins.	Oak Bracket, painted or paraffined.....	22.54
740150	1 1/2 x 2 1/4 x 12 ins.	Oak Bracket, painted or paraffined.....	22.54
740149	2 x 2 1/4 x 12 ins.	Oak Bracket, painted or paraffined.....	28.00
741159	2 x 2 3/8 x 12 ins.	Oak Bracket, painted or paraffined.....	30.94

Western Union Steel Pins

List No.	Size	Description	†List Price per 100	
			Plain	Galv.
740154	1/2 x 8 5/8 ins.	With nut washer and wooden top.....	\$12.40	\$16.40
740155	5/8 x 8 5/8 ins.	With nut washer and wooden top.....	11.06	15.34

\*F. O. B. Factories, Maryland, Indiana and Wisconsin. †F. O. B. Factory, Pittsburgh, Pa. For warehouse deliveries write nearest house.

Western Electric  
Carbolineum

List No.	Description	List Price per Gal.			
		Eastern, Central & Western Zones	Dallas	Denver & Salt Lake	Pacific Coast
741160	5 gal. cases Carbolineum.....	\$1.30	\$1.56	\$1.50	\$1.76
741161	1 to 5 bbl. lots.....	1.10	1.36	1.40	1.36
741162	5 bbl. lots or more.....	1.06	1.16	1.30	1.22

## TRANSPOSITION BRACKETS

Hot Galvanized

The No. 325 Transposition Bracket is designed to clamp over the cross arm and is held in place by means of a bolt and nut as shown in illustration. It is furnished with either  $\frac{5}{8}$  or  $\frac{1}{2}$  inch steel pin attached to the bracket by means of a nut. The pin may be easily replaced if damaged without removing the bracket. The bracket may be used with  $3\frac{1}{4}$  or 3 inch cross arms. The No. 325 type Transposition Bracket is fastened by removing nut holding the ordinary W. U. steel pin in place and substituting bracket, or where wood pins are used, bracket may be attached by a  $\frac{1}{2}$  inch carriage or machine bolt.

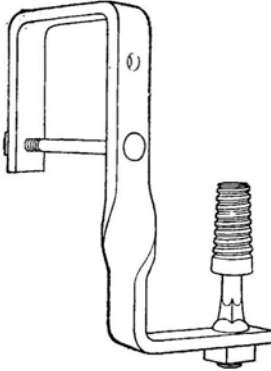

No. 325

List No.		*List Prices Each Galv.
325	Bracket with $\frac{1}{2}$ in. steel pin.....	\$0.64
325	Bracket with $\frac{5}{8}$ in. steel pin.....	.76

Orders should specify whether or not pins are required.

\*F. O. B. Factory, Pittsburgh, Pa. For warehouse deliveries, write nearest house.



No. 437



No. 237



No. 113



No. 112



No. 115

### Peirce Transposition Brackets

The brackets shown with "U" bolts are furnished with bolts bent for  $3\frac{1}{4}$  x 4 inch arm unless otherwise specified, but can be furnished with bolts bent for any size up to 4 x 5 inches. The No. 115 Bracket bolts to the shank of a  $\frac{1}{2}$  inch steel pin below the arm and is held by the pin nut. The No. 238 Bracket is for the transposition of telephone lines on routes with extremely long spaces between poles. Two brackets are needed for each "crossover."

List No.	Size of Channel	Size of Back	Size of U Bolt	Std. Bundle	Wt. Lbs.	*List Price	
						Each	Per 100
437	$\frac{3}{4}$ in.	$1\frac{3}{4}$ ins.	$\frac{5}{8}$ in.	10	400	\$1.24	\$100.80
237	$\frac{3}{4}$ in.	1 in.	$\frac{3}{8}$ in.	20	201	.60	48.96
113	$\frac{3}{4}$ in.	$1\frac{1}{4}$ ins.	0	25	156	.44	38.00
112	$\frac{3}{4}$ in.	1 in.	0	25	96	.34	27.36
115	1 in.	0	0	25	135	.39	31.68

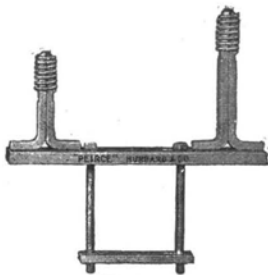

No. 238

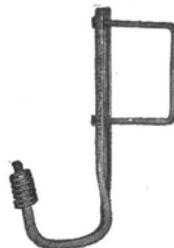

No. 110

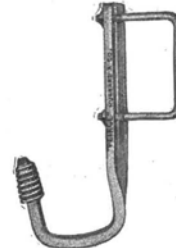

No. 111



No. 114

### Peirce Transposition Brackets

List No.	Size of Channel	Size of Back	Size of U Bolt	Std. Bundle	Wt. Lbs.	*List Price	
						Each	Per 100
238	$\frac{3}{4}$ in.	$1\frac{3}{4}$ ins.	0	10	380	\$1.24	\$100.80
110	$\frac{3}{4}$ in.	0	$\frac{5}{8}$ in.	25	108	.39	31.68
111	1 in.	0	$\frac{3}{8}$ in.	25	170	.51	41.76
114	1 in.	0	$\frac{3}{8}$ in.	25	170	.58	47.52

CROSSARM BRACES

List No.	Description	Approx. Weight per 1000	*List Price per 1000		List No.	Description	Approx. Weight per 1000	*List Price per 1000	
			Plain	Galv.				Plain	Galv.
740311	1 x 1 3/8 x 20 ins.	1125 lbs.	\$55.20	\$87.60	740320	1 1/2 x 3/2 x 32 ins.	2320 lbs.	\$113.92	\$181.68
740312	1 x 1 3/8 x 22 ins.	1230 lbs.	60.72	96.36	740321	1 1/4 x 1/4 x 20 ins.	1840 lbs.	84.18	134.28
740313	1 x 1 1/8 x 24 ins.	1335 lbs.	66.24	105.12	740322	1 1/4 x 1/4 x 22 ins.	2010 lbs.	92.58	147.54
740314	1 3/8 x 7/8 x 20 ins.	1510 lbs.	71.58	114.18	740323	1 1/4 x 1/4 x 24 ins.	2180 lbs.	100.80	160.80
740315	1 3/8 x 7/8 x 22 ins.	1645 lbs.	78.64	125.44	740324	1 1/4 x 1/4 x 26 ins.	2350 lbs.	109.04	174.08
740316	1 3/8 x 7/8 x 24 ins.	1780 lbs.	85.68	136.68	740325	1 1/4 x 1/4 x 28 ins.	2520 lbs.	117.78	187.74
740317	1 3/8 x 7/8 x 26 ins.	1915 lbs.	92.74	147.94	740326	1 1/4 x 1/4 x 30 ins.	2690 lbs.	126.00	201.00
740318	1 3/8 x 7/8 x 28 ins.	2050 lbs.	99.80	159.20	740327	1 1/4 x 1/4 x 32 ins.	2860 lbs.	134.24	214.28
740319	1 3/8 x 7/8 x 30 ins.	2185 lbs.	106.86	170.46	741253	1 3/8 x 3/8 x 28 ins.	1800 lbs.	88.20	145.16

The No. 741253 is W. U. Standard

When ordering, specify plain or galvanized.

For weight of plain braces deduct 110 lbs. from all sizes 1 inch in width, 90 lbs. from all sizes 1 1/2 inches in width, 60 lbs. from all sizes 1 1/4 inches in width, 30 lbs. from W. U. Standard size.



Guy Hook



Plain Strain Plate

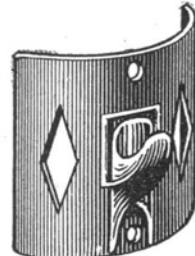

Fletcher Strain Plate

GUY HOOKS

List No.	Description	Size	Approx. Weight per 100	*List Price per 100
740328	Galvanized Guy Hooks	3/8 x 1 1/2 x 4 ins.	95 lbs.	\$19.00
741255	Galvanized Guy Hooks	3/8 x 1 1/2 x 6 ins.	125 lbs.	14.00

STRAIN PLATE

List No.	Mfr. No.	Description	Size	Approx. Weight per 100	List Price per 100
740329	..	Galvanized Strain Plate or Pole Shim, plain type	4 x 8 ins.	70 lbs.	\$17.00
741574	12	Galvanized Strain Plate or Pole Shim, Fletcher type	.....	400 lbs.	Each †1.14



No. 740



No. 742

Steel Back Braces

BACK BRACES

Hot Galvanized

For back bracing arms on corner and terminal poles. Made of 1 x 1/2 inch and 1 3/4 x 5/8 inch channel steel hot galvanized. They fit on the through bolt at pole, and are fastened to the arm with two carriage bolts. These braces are stiffer than any other form of brace for the same weight and cost.

List No.	Style	Std. Bundle	Weight per 100 Lbs.	*List Price	
				Each	Per 100
740	1 in. x 5 ft. back brace	5	410	\$0.56	\$52.08
741	1 in. x 6 ft. back brace	5	510	.68	63.24
742	1 3/4 in. x 5 ft. back brace	5	670	.78	72.54
743	1 3/4 in. x 6 ft. back brace	5	820	.90	83.70
744	1 3/4 in. x 8 ft. back brace	5	1060	1.20	111.60
745	1 3/4 in. x 9 ft. 2 ins. back brace	5	1250	1.40	130.20
746	1 3/4 in. x 4 ft. back brace	5	420	.68	63.24

\*Delivery F. O. B. Pittsburgh, Pa. For warehouse deliveries write nearest house.

†Delivery F. O. B. Dayton, O. For warehouse deliveries write nearest house.

## GALVANIZED WIRE STRAND

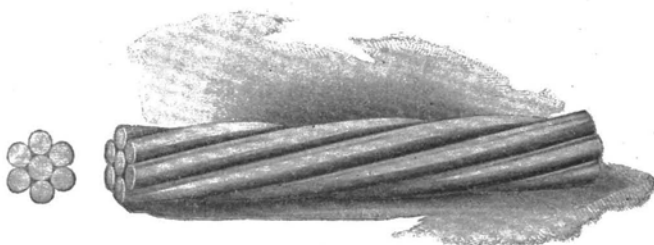

Galvanized Wire Strand

Used for guying telephone and telegraph poles, supporting aerial cables, etc. Composed of seven steel wires twisted together.

## Standard Galvanized Steel Strand

For guying poles, etc. Not suitable for supporting cables, due to its lack of strength and uniformity.

Diameter	Wt. per 1000 Ft. in Lbs.	Approx Breaking Strain in Lbs.	List Price per 100 Ft.
1/2 in.	510	8500	On request
7/16 in.	415	6500	
3/8 in.	295	5000	
5/16 in.	210	3800	
1/4 in.	125	2300	
7/32 in.	95	1800	
3/16 in.	75	1400	
5/32 in.	55	900	
1/8 in.	32	500	
3/32 in.	20	400	

Galvanized strand is furnished both single and double galvanized. In ordering, state which is required.

## Siemens-Martin Strand

Diameter Ins.	Approx. Breaking Strength in Lbs.	List Price per 100 Ft.	Diameter, Ins.	Approx. Breaking Strength in Lbs.	List Price per 100 Ft.
5/8	19000	On request	9/32	4380	On request
1/2	11000		1/4	3050	
7/16	9000		3/16	2000	
3/8	6800		1/8	900	
5/16	4860				

## Extra Galvanized, High Strength Strand

Manufactured under Western Electric specifications. For supporting aerial cables or for use wherever a high-grade, high-strength strand is required.

Diameter Ins.	Approx. Breaking Strength in Lbs.	Size of Wire	Will Support Cable		List Price per 100 Ft.
			No. 19 Gauge	No. 22 Gauge	
5/16	6000	12 B.W.G.	50 pair	100 pair	On request
3/8	10000	11 B.W.G.	100 pair	200 pair	request
7/16	16000	9 B.W.G.	Large sizes		

## GUY ANCHORS AND ANCHOR RODS

### Bierce Guy Anchors

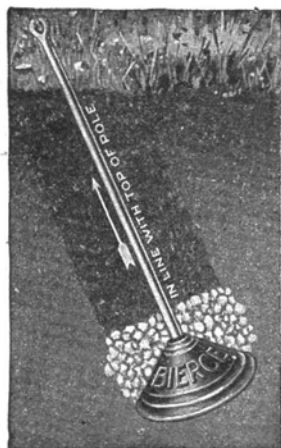

"Bierce" Anchor

The "Bierce" Anchor works on the principle of the inverted wedge. It has exceptional holding power in dry sand or swampy soil. In a recent series of tests, the 8 inch size held over 16,000 pounds in clay and over 13,000 pounds in dry sand. It does away with expanding, screwing, driving or guessing. One man can bore hole with auger, set anchor and tamp it in fifteen minutes. It is made in one solid piece.

To install, bore a hole not less than five feet with an earth auger of same diameter as "Bierce" Anchor. Use  $\frac{1}{2}$  inch,  $\frac{5}{8}$  inch or  $\frac{3}{4}$  inch anchor rods as desired for 8 inch size and 1 inch rods for 12 inch size. Drop the anchor into the hole with the point up. Tamp a quantity of broken stone or brick firmly around the anchor and it is ready to attach to the guy wire. The earth may be back filled loosely or tamped, as desired. We recommend the 8 inch anchor for a general purpose and the 12 inch for dead-ending lines under heavy strain.

List No.	Diam.	Wgt. lbs. per 100	*List Price Each		
			Less than 50	50 to 100	100 or More
740981	5 in. "Bierce" Anchor.....	230	\$0.90	\$0.80	\$0.70
740982	6 in. "Bierce" Anchor.....	290	1.00	.90	.80
740983	8 in. "Bierce" Anchor.....	530	1.20	1.10	1.00
740984	12 in. "Bierce" Anchor.....	1300	2.20	2.10	2.00

\*F. O. B. Factory, Cincinnati, Ohio. For warehouse deliveries write nearest house.

NOTE: Prices do not include rods.



### Anchor Rods

List No.	Size	Weight per 100		†List Price per 100	
		Plain	Galv.	Plain	Galv.
740416	$\frac{1}{2}$ in. x 6 ft.....	420 lbs.	460 lbs.	\$32.40	\$51.74
740417	$\frac{1}{2}$ in. x 7 ft.....	485 lbs.	530 lbs.	36.14	58.14
740418	$\frac{1}{2}$ in. x 8 ft.....	550 lbs.	600 lbs.	39.88	66.94
740419	$\frac{5}{8}$ in. x 6 ft.....	645 lbs.	710 lbs.	45.06	72.28
740420	$\frac{5}{8}$ in. x 7 ft.....	750 lbs.	825 lbs.	50.66	82.14
740421	$\frac{5}{8}$ in. x 8 ft.....	880 lbs.	990 lbs.	56.28	92.00
740422	$\frac{3}{4}$ in. x 6 ft.....	1000 lbs.	1100 lbs.	57.00	92.04
740423	$\frac{3}{4}$ in. x 7 ft.....	1150 lbs.	1260 lbs.	64.20	104.64
740424	$\frac{3}{4}$ in. x 8 ft.....	1300 lbs.	1430 lbs.	71.40	117.24
740425	1 in. x 8 ft.....	2575 lbs.	2840 lbs.	138.24	225.00
740426	1 in. x 9 ft.....	2738 lbs.	3010 lbs.	150.96	247.20
740427	1 in. x 10 ft.....	2900 lbs.	3190 lbs.	163.68	269.40
740428	1 in. x 11 ft.....	3033 lbs.	3360 lbs.	176.40	291.60
740429	1 in. x 12 ft.....	3165 lbs.	3480 lbs.	199.12	313.80

NOTE: Anchor rod with eye at each end will be furnished at the same price as the regular anchor rod with eye at one end, thread and nut at other.

Prices on rods include nuts, but not washers.

When ordering, specify plain or galvanized.

### Harpoon Guy Anchors

Harpoon Guy Anchors are made of steel throughout. They are driven down with a sledge and set by a pull. One man can install a Harpoon Guy Anchor in ten minutes. No digging, boring, tamping or special tool is required. The wings open out in the undisturbed ground and will withstand any strain met in ordinary pole line service.

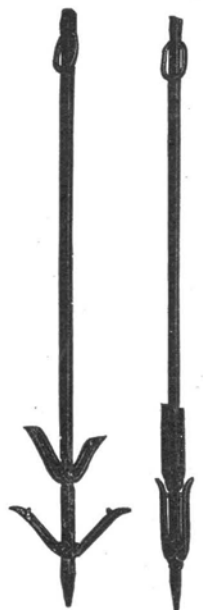

Open

Closed

List No.	Length Rod	Finish	Wt. Lbs.	†List Price Each		
				1 to 49	50 to 99	100 and Over
741274	5 ft.	Black enamel.....	23	\$2.90	\$2.70	\$2.60
741275	5 ft.	Galvanized.....	23	4.50	4.20	4.00

†Delivery F. O. B. Pittsburgh, Pa.

†Delivery F. O. B. Syracuse, N. Y. For warehouse deliveries write nearest house.

## GUY ANCHORS

### Matthews Sculix Anchors

These anchors are screwed down into the solid ground without disturbing it. Each turn of the helix causes it to feed down into the ground and as it goes down the upper half again compresses the earth so that it is as solid above the anchor as around it.

All other types of ground anchors have moving parts which must be adjusted and which are frequently buried unadjusted, and they require a hole to be dug before installing. It is argued that this is wrong in principle because the filled hole of soft dirt above the anchor allows the rain and snow water to gradually soften the dirt and decrease the resistance of the earth above the anchor. The intermittent strains on the line have a tendency to raise the anchor up into this filled and softened earth. The results must necessarily be less satisfactory than with the Matthews Sculix Anchor.

Matthews Sculix Anchors are screwed into solid ground and afford the maximum of resistance to the upward pull of the guy lines.

Manufacturer absolutely guarantees the ungalvanized 5, 6 and 7 inch Matthews Sculix Anchors to outlast any other anchors using galvanized steel rods of the same cross section, and they guarantee the ungalvanized 8, 10 and 12 inch Matthews Sculix Anchors with square rods to outlast the same round section galvanized.

Twelve or more Matthews Sculix Anchors and one No. 567 Wrench for their installation will be sent on thirty days' trial, charges prepaid, on the first order only. If unsatisfactory, they may be returned, freight charges collect.



The Ratchet Handle No. 765

Mfr. No.	Diam. of Anchor	List Prices per 100, Galv.			Net Additions for Delivery on Pacific Coast
		Less than 12	Less than 50 and over 11	50 or More	
502 R	5 in.	\$200.00	\$182.00	\$170.00	\$0.11
603 R	6 in.	293.34	269.34	249.34	.18
704 R	7 in.	456.68	426.68	396.68	.26
567	Wrench	693.00	663.00	612.00	.32
*765	Handle	700.00	700.00	700.00	.00
800	8 in.	793.34	793.34	793.34	.67
1000	10 in.	1134.34	1134.34	1134.34	.88
1200	12 in.	1700.00	1700.00	1700.00	1.40

The above prices are for points east of Pacific Coast States. Add the amounts under Pacific Coast to the net cost per anchor to get prices in Pacific Coast States. The cost of galvanized anchors is found by adding the amounts under that heading to the net cost per anchor.

#### Sizes and Data

Mfr. No.	Wt., Lbs.	Size of Rods	Description	Remarks
502 R	6½	½ inch round	Rod anchor for lightest strains	All rod anchors are 6 feet long over all. A number 567 wrench must be used with all anchors smaller than 800. No wrench is needed for the 800, 1000, or 1200 anchors. * The 765 ratchet handle is for use with the 567 wrench, and is very useful where it is desired to put the anchor down next to walls, fences, etc.
603 R	10	⅝ inch round	Rod anchor for medium strains	
704 R	15	¾ inch round	Rod anchor for heavy strains	
567	25	Wrench	For installing the above anchors	
765	7	Ratchet Handle for above	See (*) Remarks	
800	38	1⅝ inch square	Rod anchor for heavy strains	
1000	50	1¾ inch square	Rod anchor for heavier strains	
1200	80	1½ inch square	Rod anchor for very heavy strains	

GUY CLAMPS



"Baby" Clamp



"Giant" Clamp

Matthews Boltless Guy Clamps

These clamps are made in two sizes, known as the "Baby" and the "Giant." The "Baby" is designed to fit 1/4 and 5/16 inch guy strand. The "Giant" is designed to fit 5/8 and 3/4 inch guy strand.

The Matthews "Baby" Boltless Guy Clamp will safely hold all strains on 1/4 and 5/16 inch guy strand. It is largely used for 5/16 inch guy wire and by electric railway companies for holding 1/4 inch trolley span wires.

Matthews "Giant" Boltless Guy Clamp is used for holding strains on 5/8 inch, and 3/4 inch guy strand.

These Clamps can be installed in less than 4 minutes and cost 21% less installed than ordinary 3-bolt clamps.

The greater the strain on the clamp the more they will hold. The wedge cannot be removed until the guys have been slacked.

List No.	Description	Approx. Wt. per 100	*List Price Each		
			Less than 500	500 and less 1000	1000 or More
740510	"Baby" Clamp.....	40	\$0.20	\$0.20	\$0.16
740511	"Giant" Clamp.....	130	.30	.28	.26

NOTE: For Pacific Coast deliveries add 3 cents for the "Giant" Clamp and 1 cent to the "Baby" Clamp lists.

NOTE: Matthews Boltless Guy Clamps may be assorted with each other or with Matthews 2-Bolt Guy Clamp described below, to obtain the benefit of the quantity prices.

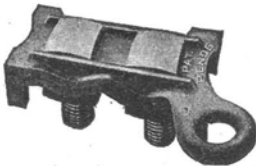

Showing Top

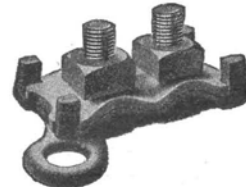

Showing Bottom

Matthews Two Bolt Guy Clamp

Next to Matthews Boltless Clamps described above this clamp is the easiest to install, and it is the strongest clamp made. It will break 16,000 lb. strand. This means that it will hold more than 5 ordinary 3-bolt clamps. For splicing messenger and for all other messenger and heavy guying it is the most economical clamp made. The four feet on the sides of one of the clamping plates prevent the guys from jumping out while slack is being taken up. The ear on this clamp is used for pulling the clamp to its final position while the clamping plates are still loose. This prevents the possibility of scraping off the galvanizing on the strand and the nicking of the strand by misdirected hammer blows, which happens so often when 3-bolt clamps are installed. A chain lever is furnished for the purpose of pulling up the clamp.

List No.	Description	*List Price Each	
		Less than 1000	1000 and Over
740508	2-Bolt Guy Clamp.....	\$0.44	\$0.40

NOTE: For Pacific Coast deliveries add 7 cents to list.

List No.	Chain Lever	*List Price Each
		Each
740505	Chain Lever for use with 2-Bolt Guy Clamp.....	\$3.00

NOTE: Matthews 2-Bolt Guy Clamps may be assorted with Matthews Boltless Guy Clamps described above, to obtain the benefit of quantity prices.

\*Delivery F. O. B. Factory St. Louis, Mo. For warehouse deliveries write nearest house.

## GUY CLAMPS

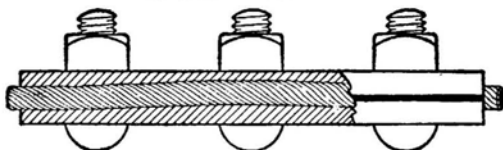

No. 400

### Rolled Steel Guy Clamps

For fastening guy wires and cables. Furnished with bolts 1/2 inch diameter.

List No.	Guy Clamp	Bolt	For Strand	Length	Wt. per 100	*List Price per 100
402	Guy Clamp	2	5/8 in. and larger	3 ins.	110	\$17.48
403	Guy Clamp	2	3/8 to 1/2 in.	3 ins.	125	17.48
400	Guy Clamp	3	1/2 in. and larger	6 ins.	200	27.88
401	Guy Clamp	3	3/8 to 1/2 in.	6 ins.	226	27.88
*404	Guy Clamp	3	1/2 to 1/2 in.	6 ins.	205	27.88

\*No. 404 has 1/2 inch diameter bolts in each end only and center hole 5/8 inch diameter.

## WIRE ROPE THIMBLES

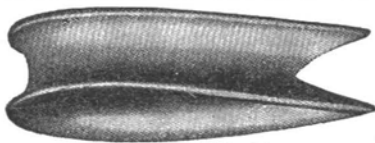

Wire Rope Thimble

List No.	Width of Score	Circumference of Rope	List Price per 100 Galv.	List No.	Width of Score	Circumference of Rope	List Price per 100 Galv.
741414	1/8 in.	1/2 or 5/8 in.	\$3.00	741424	1 in.	3 ins.	\$14.58
741415	1/4 in.	3/4 in.	3.00	741425	1 1/8 ins.	3 1/2 ins.	22.68
741416	5/16 in.	7/8 in.	3.60	741426	1 1/4 ins.	3 3/4 ins.	26.72
741417	3/8 in.	1 in.	4.20	741427	1 3/8 ins.	4 ins.	34.06
741418	1/2 in.	1 1/4 ins.	4.80	741428	1 1/2 ins.	4 1/2 ins.	40.50
741419	5/8 in.	1 1/2 ins.	5.40	741429	1 5/8 ins.	5 ins.	78.00
741420	3/4 in.	1 3/4 ins.	7.50	741430	1 3/4 ins.	5 1/2 ins.	90.00
741421	7/8 in.	2 ins.	7.66	741431	1 7/8 ins.	5 3/4 ins.	114.00
741422	1 in.	2 1/2 ins.	9.66	741432	2 ins.	6 ins.	132.00
741423	1 1/8 in.	2 3/4 ins.	11.10	741433	2 1/4 ins.	6 1/2 ins.	189.00
				741434	2 1/2 ins.	7 1/2 ins.	249.60

## WIRE ROPE CLIPS

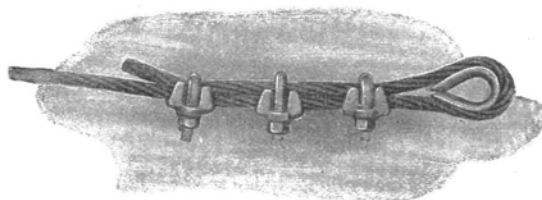

Crosby Clips



Bulldog Clip

This Clip is the only drop-forged galvanized clip made. Die-forged, cannot break; galvanized, cannot rust.

List No.	Size Strand	List Price Each	List No.	Size Strand	List Price Each
740390	1/4 in. strand	\$0.35	740399	1 1/8 in. strand	\$1.14
740391	5/16 in. strand	.35	740400	1 1/4 in. strand	1.32
740392	3/8 in. strand	.35	740401	1 3/8 in. strand	1.50
740393	7/16 in. strand	.42	740402	1 1/2 in. strand	1.80
740394	1/2 in. strand	.42	740403	1 5/8 in. strand	4.20
740395	5/8 in. strand	.66	740404	1 3/4 in. strand	6.60
740396	3/4 in. strand	.78	740405	2 in. strand	9.00
740397	7/8 in. strand	.90	740406	2 1/4 in. strand	11.40
740398	1 in. strand	1.02	740407	2 1/2 in. strand	13.80

### BULLDOG CLIPS

Galvanized

740408	1/4 in. strand	\$0.11	740412	5/8 in. strand	\$0.22
740409	5/16 in. strand	.11	740413	3/4 in. strand	.26
740410	3/8 in. strand	.13	740414	7/8 in. strand	.36
740411	1/2 in. strand	.17	740415	1 in. strand	.43

**POLE CLAMPS**

**Messenger Clamps**

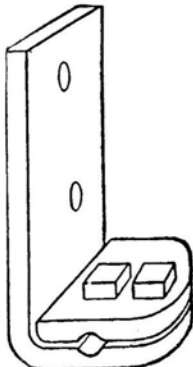

Standard

**TWO BOLT**

List No.		Weight per 100	*List Price Each
740512	2 bolt, plain, for $\frac{5}{16}$ and $\frac{7}{16}$ in. strand.....	222 lbs.	Special
740513	2 bolt, galvanized, for $\frac{5}{16}$ and $\frac{7}{16}$ in. strand...	233 lbs.	Special
740514	2 bolt, plain, for $\frac{7}{16}$ and $\frac{1}{2}$ in. strand.....	300 lbs.	Special
740515	2 bolt, galvanized, for $\frac{7}{16}$ and $\frac{1}{2}$ in. strand..	315 lbs.	Special

**Universal Messenger Clamp**

These clamps are especially adapted for use on corners as well as straight work on account of the shape of the groove. The bolts are heavy and made from high-tensile stock, so that the messenger strand can be clamped securely at each plate.

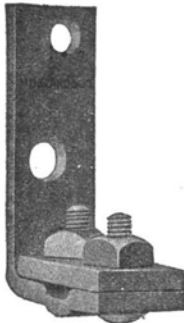

Universal

List No.		*List Price Each
1	$\frac{1}{2}$ x 2 in., galvanized.....	\$0.87
2	$\frac{3}{8}$ x $1\frac{1}{2}$ in., galvanized.....	.81

**Curve Block**

Curve blocks are for easing strand around corners and curves. The same block can be used on an in or out curve.



Curve Block

List No.		†List Price Each		List Price per 100	
		Plain	Galv.	Plain	Galv.
1	For $\frac{1}{2}$ in. strand.....	\$0.48	\$0.57	\$45.00	\$54.00
2	For $\frac{3}{8}$ in. strand.....	.38	.48	36.00	45.00
3	For $\frac{1}{4}$ in. strand.....	.29	.38	27.00	36.00

**Messenger Clamp**

**ONE BOLT**

$2\frac{1}{8}$  inches wide,  $2\frac{1}{2}$  inches long, hole for  $\frac{5}{8}$  inch bolt.

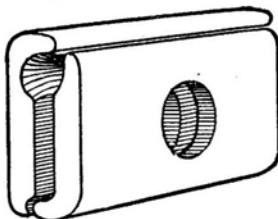

One Bolt Messenger Clamp

List No.		Weight per 100 Pr.	*List Price per 100 Pr.
740522	Galvanized.....	86 lbs.	\$21.00

**No. 4 Messenger Support**

This messenger support is intended for light cable work. One lag screw clamps messenger and fastens the support to the pole.

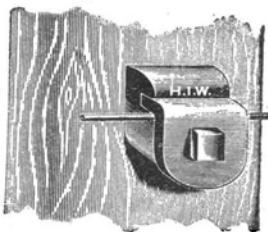

No. 4 Messenger Clamp

List No.		†List Price Each	List Price per 100
740523	Support for No. 4 B. W. G. wire or $\frac{1}{4}$ in. strand, plain.....	\$0.16	\$11.40
740524	Support for No. 4 B. W. G. wire or $\frac{1}{4}$ in. strand, galvanized.....	.23	15.96

\*Delivery F. O. B. Pittsburgh, Pa. †Delivery F. O. B. Chicago, Ill. For warehouse deliveries write nearest house.

## CROSSARM AND BRACE BOLTS

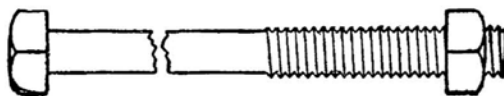

## Crossarm Bolts

## Standard Machine Bolts

With Square Heads and Square Nuts. Finished Points

\*Manufacturer's Standard List. In Effect August 1, 1912  
Price per 100. Special Discounts on Application

Diameter

Length Inches	$\frac{1}{4}$ Inch	$\frac{3}{8}$ Inch	$\frac{1}{2}$ Inch	$\frac{3}{8}$ Inch	$\frac{1}{2}$ Inch	$\frac{5}{8}$ and $\frac{3}{4}$ Inch	$\frac{3}{4}$ Inch	$\frac{7}{8}$ Inch	1 Inch
$\frac{3}{4}$ to $1\frac{1}{2}$ .....	\$1.70	\$2.00	\$2.40	\$2.80	\$3.60	\$5.20	\$7.70	\$10.50	\$15.10
2 .....	1.78	2.12	2.56	3.00	3.86	5.58	8.25	11.20	16.00
$2\frac{1}{2}$ .....	1.86	2.24	2.72	3.20	4.12	5.96	8.80	11.90	16.90
3 .....	1.94	2.36	2.88	3.40	4.38	6.34	9.35	12.60	17.80
$3\frac{1}{2}$ .....	2.02	2.48	3.04	3.60	4.64	6.72	9.90	13.30	18.70
4 .....	2.10	2.60	3.20	3.80	4.90	7.10	10.45	14.00	19.60
$4\frac{1}{2}$ .....	2.18	2.72	3.36	4.00	5.16	7.48	11.00	14.70	20.50
5 .....	2.26	2.84	3.52	4.20	5.42	7.86	11.55	15.40	21.40
$5\frac{1}{2}$ .....	2.34	2.96	3.68	4.40	5.68	8.24	12.10	16.10	22.30
6 .....	2.42	3.08	3.84	4.60	5.94	8.62	12.65	16.80	23.20
$6\frac{1}{2}$ .....	2.50	3.20	4.00	4.80	6.20	9.00	13.20	17.50	24.10
7 .....	2.58	3.32	4.16	5.00	6.46	9.38	13.75	18.20	25.00
$7\frac{1}{2}$ .....	2.66	3.44	4.32	5.20	6.72	9.76	14.30	18.90	25.90
8 .....	2.74	3.56	4.48	5.40	6.98	10.14	14.85	19.60	26.80
9 .....	2.90	3.80	4.80	5.80	7.50	10.90	15.95	21.00	28.60
10 .....	3.06	4.04	5.12	6.20	8.02	11.66	17.05	22.40	30.40
11 .....	3.22	4.28	5.44	6.60	8.54	12.42	18.15	23.80	32.20
12 .....	3.38	4.52	5.76	7.00	9.06	13.18	19.25	25.20	34.00
13 .....	.....	.....	6.08	7.40	9.58	13.94	20.35	26.60	35.80
14 .....	.....	.....	6.40	7.80	10.10	14.70	21.45	28.00	37.60
15 .....	.....	.....	6.72	8.20	10.62	15.46	22.55	29.40	39.40
16 .....	.....	.....	7.04	8.60	11.14	16.22	23.65	30.80	41.20
17 .....	.....	.....	.....	.....	11.66	16.98	24.75	32.20	43.00
18 .....	.....	.....	.....	.....	12.18	17.74	25.85	33.60	44.80
19 .....	.....	.....	.....	.....	12.70	18.50	26.95	35.00	46.60
20 .....	.....	.....	.....	.....	13.22	19.23	28.05	36.40	48.40

The following extras are to be understood as a part of the above list: Bolts with hexagon heads or hexagon nuts, 10 per cent. extra. If both hexagon heads and hexagon nuts, 20 per cent. extra. Machine bolts when fitted with U. S. Standard Square Nuts, add 5 per cent. Machine bolts when fitted with U. S. Standard Hexagon Nuts, add 15 per cent.

## Brace Bolts

## Standard Carriage Bolts

\*Manufacturer's Standard List, November 1, 1912

Price per 100. Special Discounts on Application

Diameter

Length Inches	$\frac{3}{16}$ and $\frac{1}{4}$ In.	$\frac{5}{16}$ Inch	$\frac{3}{8}$ Inch	$\frac{7}{16}$ Inch	$\frac{1}{2}$ Inch	$\frac{5}{8}$ and $\frac{3}{4}$ Inch	$\frac{3}{4}$ Inch
1 .....	\$1.00	\$1.40	\$1.90	\$2.20	\$3.25	\$5.75	\$8.50
$1\frac{1}{2}$ .....	1.00	1.40	1.90	2.20	3.25	5.75	8.50
2 .....	1.10	1.52	2.06	2.40	3.25	5.75	8.50
$2\frac{1}{2}$ .....	1.20	1.64	2.22	2.60	3.25	5.75	8.50
3 .....	1.30	1.76	2.38	2.80	3.53	6.13	9.00
$3\frac{1}{2}$ .....	1.40	1.88	2.54	3.00	3.81	6.51	9.50
4 .....	1.50	2.00	2.70	3.20	4.09	6.89	10.00
$4\frac{1}{2}$ .....	1.60	2.12	2.86	3.40	4.37	7.27	10.50
5 .....	1.70	2.24	3.02	3.60	4.65	7.65	11.00
$5\frac{1}{2}$ .....	1.80	2.36	3.18	3.80	4.93	8.03	11.50
6 .....	1.90	2.48	3.34	4.00	5.21	8.41	12.00
$6\frac{1}{2}$ .....	2.00	2.60	3.50	4.20	5.49	8.79	12.50
7 .....	2.10	2.72	3.66	4.40	5.77	9.17	13.00
$7\frac{1}{2}$ .....	2.20	2.84	3.82	4.60	6.05	9.55	13.50
8 .....	2.30	2.96	3.98	4.80	6.33	9.93	14.00

Washers are not furnished with bolts. Bolts with hexagon nuts, 15 per cent. extra. Intermediate lengths take next longer list. Larger diameters take machine bolt list.

\*Delivery F. O. B. Factory, Pittsburgh, Pa. For warehouse deliveries write nearest house.

**SPACING BOLTS AND LAG SCREWS**

Double Arming Bolts



**Spacing Bolts**

Furnished with 4 Nuts, No Washers

Size	Wt. Lbs. per 100	*List Price per 100 †Galv.	Size	Wt. Lbs. per 100	*List Price per 100 †Galv.	Size	Wt. Lbs. per 100	*List Price per 100 †Galv.
1/2 x 12.....	78.0	\$20.32	5/8 x 12.....	138.0	\$20.44	3/4 x 12.....	220.0	\$30.24
1/2 x 13.....	83.0	21.16	5/8 x 13.....	145.0	21.32	3/4 x 13.....	232.0	31.42
1/2 x 14.....	88.0	22.00	5/8 x 14.....	153.0	22.02	3/4 x 14.....	244.0	32.56
1/2 x 15.....	93.0	22.82	5/8 x 15.....	162.0	22.82	3/4 x 15.....	256.0	33.72
1/2 x 16.....	98.0	23.66	5/8 x 16.....	168.0	23.62	3/4 x 16.....	268.0	34.88
1/2 x 17.....	103.0	16.08	5/8 x 17.....	178.0	24.42	3/4 x 17.....	280.0	36.02
1/2 x 18.....	108.0	16.64	5/8 x 18.....	188.0	25.20	3/4 x 18.....	292.0	37.18
1/2 x 19.....	113.0	17.16	5/8 x 19.....	198.0	25.98	3/4 x 19.....	304.0	38.34
1/2 x 20.....	118.0	17.72	5/8 x 20.....	208.0	26.82	3/4 x 20.....	316.0	39.50

†Prices on plain bolts on application.

**Standard Lag Screws**

With Square Head and Gimlet Point

\*Manufacturers' Standard List. In effect November 12, 1908.

List Price per 100. Special discounts on application.

Diameter



Length Inches	1/4 Inch	5/16 Inch	3/8 Inch	7/16 Inch	1/2 Inch	5/8 and 5/8 Inch	3/4 Inch	7/8 Inch	1 Inch
1 1/2.....	\$2.25	\$2.70	\$3.15	\$3.75	\$6.00	.....	.....	.....	.....
2.....	2.45	2.96	3.47	4.11	6.50	.....	.....	.....	.....
2 1/2.....	2.65	3.22	3.79	4.47	7.00	\$9.20	.....	.....	.....
3.....	2.85	3.48	4.11	4.83	7.50	9.90	\$15.00	.....	.....
3 1/2.....	3.05	3.74	4.43	5.19	8.00	10.60	16.00	\$22.00	.....
4.....	3.25	4.00	4.75	5.55	8.50	11.30	17.00	23.30	.....
4 1/2.....	3.45	4.26	5.07	5.91	9.00	12.00	18.00	24.60	.....
5.....	3.65	4.52	5.39	6.27	9.50	12.70	19.00	25.90	.....
5 1/2.....	3.85	4.78	5.71	6.63	10.00	13.40	20.00	27.20	.....
6.....	4.05	5.04	6.03	6.99	10.50	14.10	21.00	28.50	.....
6 1/2.....	4.25	5.30	6.35	7.35	11.00	14.80	22.00	29.80	.....
7.....	4.45	5.56	6.67	7.71	11.50	15.50	23.00	31.10	.....
7 1/2.....	4.65	5.82	6.99	8.07	12.00	16.20	24.00	32.40	.....
8.....	4.85	6.08	7.31	8.43	12.50	16.90	25.00	33.70	.....
9.....	5.25	6.60	7.95	9.15	13.00	18.30	27.00	36.30	.....
10.....	5.65	7.12	8.59	9.87	14.00	19.70	29.00	38.90	.....
11.....	6.05	7.64	9.23	10.59	15.00	21.10	31.00	41.50	.....
12.....	6.45	8.16	9.87	11.31	16.00	22.50	33.00	44.10	.....
Adv. per in.	\$0.24	\$0.32	\$0.39	\$0.44	\$0.60	\$0.84	\$1.20	\$1.56	

For Hexagon nuts, add 10 per cent.

**Approximate Weight**

Weight in Pounds of 100 Bolts of Sizes Enumerated Below Diameter

Length Inches	1/4 Inch	5/16 Inch	3/8 Inch	7/16 Inch	1/2 Inch	5/8 Inch	3/4 Inch	7/8 Inch	1 Inch
1 1/2.....	2.7	3.5	5.8	9.1	.....	.....	.....	.....	.....
2.....	3.5	4.4	7.1	11.0	15.0	22.8	26.3	.....	.....
2 1/2.....	4.2	5.3	8.5	12.9	17.3	25.3	29.9	.....	.....
3.....	4.7	6.2	9.8	14.8	19.5	27.8	33.5	46.1	71.8
3 1/2.....	5.2	7.1	11.1	16.5	21.6	30.4	37.1	51.5	78.5
4.....	5.7	8.0	12.5	18.2	23.8	33.0	40.7	57.1	85.3
4 1/2.....	6.5	9.0	13.8	19.9	26.3	35.5	44.5	62.9	92.0
5.....	7.0	10.0	14.9	21.8	28.8	38.0	48.3	68.8	98.6
5 1/2.....	7.5	11.0	16.0	23.5	31.3	40.7	52.0	74.7	105.3
6.....	8.0	12.0	17.2	25.2	33.8	43.3	55.7	80.5	112.0
7.....	.....	.....	.....	.....	38.9	50.8	63.2	92.3	125.4
8.....	.....	.....	.....	.....	44.0	56.8	69.3	104.0	138.8
9.....	.....	.....	.....	.....	48.5	63.5	76.4	115.4	156.3

\*Delivery F. O. B. Pittsburgh. For warehouse deliveries write nearest house.

Telephone Apparatus and Supplies

MISCELLANEOUS POLE STEPS

Pole Steps  
Fetter Drive

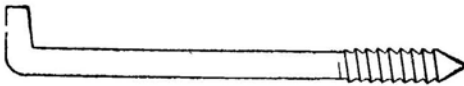

Standard



Button Head

STANDARD

List No.	Size in Inches	Approximate Wt. per 100		*List Price per 1000	
		Plain	Galv.	Plain	Galv.
740188	1 1/8 x 9	65 lbs.	68 lbs.	\$47.62	\$72.68
740189	1 1/8 x 10 1/2	75 lbs.	78 lbs.	53.62	82.94
740190	5/8 x 9	81 lbs.	85 lbs.	59.60	90.28
740191	5/8 x 10	91 lbs.	95 lbs.	64.28	98.40

BUTTON HEAD

740193	5/8 x 10	87 lbs.	90 lbs.	\$65.34	\$100.00
--------	----------	---------	---------	---------	----------

When ordering, specify plain or galvanized.

WOODEN POLE STEP

This pole step is of oak, drilled for two spikes, and is easily nailed up against the pole.



List No.	Description	List Price per 1000
740194	Oak Pole Step, plain	†\$17.50
740195	Oak Pole Step, creosoted	†20.00
741628	Oak Pole Step, paraffined	†20.00

CUTTER REMOVABLE POLE STEP

Weigh less than 14 ozs. per pair, and are much more easily carried than a ladder. The sockets for them are hooked under so as to be sleet-proof.

List No.	Description	Std. Pkg.	†List Price Each
20885	Pole Step, painted	250	\$0.30
20886	Socket, painted	250	.18
20887	Pole Step, galvanized	250	.36
20888	Socket, galvanized	250	.24

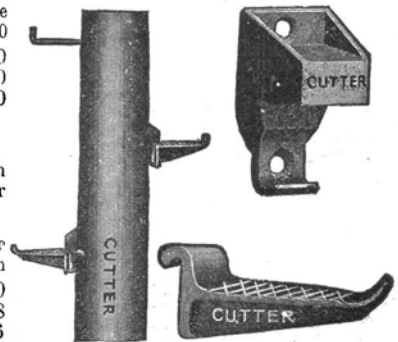

Cutter Removable Pole Step

[(Wooden] Pole Step]



Pole Step for Iron Poles



Removable Step



Socket

McEride Pole Step

POLE STEPS FOR IRON POLES

List No.	Description	††List Price Each
740200	Pole Step, for 4 in. pipe, with bolt	\$0.47
740201	Pole Step, for 5 in. pipe, with bolt	.51
740202	Pole Step, for 6 in. pipe, with bolt	.55
740203	Pole Step, for 7 in. pipe, with bolt	.58
740204	Pole Step, for 8 in. pipe, with bolt	.62

McBRIDE REMOVABLE POLE STEP

List No.	Description	Approximate Wt. per 100		*List Price per 100 Pieces	
		Plain	Galv.	Plain	Galv.
740205	Pole Step and Socket	75 lbs.	80 lbs.	\$13.00	\$16.50

\*Delivery F. O. B. Pittsburgh, Pa. †Delivery F. O. B. South Bend, Ind.  
 †Delivery F. O. B. Factories, Maryland, Wisconsin and Indiana. ††Delivery F. O. B. Newark, N. J.  
 ^Delivery F. O. B. St. Louis, Mo.

For warehouse deliveries write nearest house.



## EXPANSION BOLTS

### Expansion Bolts and Shields



Shield with Screw



Shield

#### MALLEABLE SHIELDS

##### Dimensions, Malleable Shields Only

Dia. of screw . . . . .	1/4 in.	5/16 in.	3/8 in.	7/16 in.	1/2 in.	5/8 in.	3/4 in.	7/8 in.	1 in.	1 1/4 ins.
Outside dia. shield.	1/2 in.	5/8 in.	3/4 in.	7/8 in.	1 in.	1 1/8 ins.	1 1/2 ins.	1 3/4 ins.	1 7/8 ins.	1 3/4 ins.
Length of shield . . .	1 1/2 ins.	1 3/4 ins.	2 3/4 ins.	2 3/4 ins.	3 1/2 ins.	3 1/2 ins.	3 3/4 ins.	5 ins.	5 ins.	8 ins.
Dia. drill required . .	1/2 in.	5/16 in.	3/8 in.	7/16 in.	3/4 in.	5/8 in.	1 1/8 ins.	1 3/8 ins.	1 1/2 ins.	1 7/8 ins.

##### List Price per 100 Shields Without Lag Screws

Dia. of screw . . . . .	1/4 in.	5/16 in.	3/8 in.	7/16 in.	1/2 in.	5/8 in.	3/4 in.	7/8 in.	1 in.	1 1/4 ins.
List price per 100 . .	\$5.64	\$6.30	\$8.02	\$10.66	\$13.20	\$16.68	\$23.98	\$31.98	\$39.96	\$60.00

##### List Price per 100 Shields With Square Head Lag Screws

Length, Inches	List Price per 100 Shields With Square Head Lag Screws									
1 1/2 . . . . .	\$6.08	\$6.96	.....	.....	.....	.....	.....	.....	.....	.....
2 . . . . .	6.52	7.00	.....	.....	.....	.....	.....	.....	.....	.....
2 1/2 . . . . .	6.60	7.12	\$9.54	\$12.18	\$14.50	\$19.02	\$28.98	.....	.....	.....
3 . . . . .	6.76	7.20	9.66	12.30	14.68	19.26	29.32	.....	.....	.....
4 . . . . .	6.90	7.42	9.84	12.48	15.22	19.74	30.00	.....	.....	.....
5 . . . . .	7.12	7.60	10.14	12.70	15.54	20.26	30.64	.....	.....	.....
6 . . . . .	7.32	7.80	10.42	12.90	15.88	20.76	31.32	\$41.34	\$47.74	.....
7 . . . . .	.....	7.98	10.60	13.08	16.20	21.24	31.98	42.00	49.00	.....
8 . . . . .	.....	.....	10.80	13.30	16.56	21.76	32.08	42.66	50.02	\$104.68
9 . . . . .	.....	.....	.....	13.50	16.86	22.26	33.34	43.32	51.46	108.66

Ten per cent. extra for hexagon heads. In figuring lists for longer bolts than those given above, make same advance per inch as on list.  
 NOTE: Standard package of all type shields or shield and screws is 100.

#### COMPOSITION SCREW ANCHORS

##### With Brass Screws



Anchor with Screw

The following list covers anchors not over 1 inch in length complete with flat, round or oval head brass screws.



Anchor

Diameter of Anchor	Length of Anchor	No. of Screw	List Price per 100—Length of Screw				
			3/4 in.	1 In.	1 1/2 Ins.	2 Ins.	2 1/2 Ins.
1/8 in. . . . .	1/2, 3/4, 1 in.	5-6-7-8	\$3.66	\$3.72	\$4.50	\$5.70	\$8.02
3/16 in. . . . .	1/2, 3/4, 1 in.	9-10-11	4.74	5.10	5.70	6.60	8.62
1/4 in. . . . .	1/2, 3/4, 1 in.	12-13-14	5.76	6.30	7.26	8.34	9.66
5/16 in. . . . .	3/4, 1 in.	15-16-17-18	7.36	8.10	10.12	11.92	13.66

NOTE: Standard package of all type shields or shields and screws is 100.

#### ONE PART DIAMOND EXPANSION SHIELDS

##### Composition

List No.	No. Inches	No. of Screw	Length of Shield	Outside Diam.	List Price per 100	List No.	No. Inches	No. of Screw	Length of Shield	Outside Diam.	List Price per 100
740224	1/8 x 1/2	5-6-7-8	1/2	1/4	\$2.64	740234	1/4 x 1	12-13-14	1	3/8	\$3.36
744225	1/8 x 5/8	5-6-7-8	5/8	1/4	2.64	740235	1/4 x 1 1/2	12-13-14	1 1/2	3/8	4.06
740226	1/8 x 3/4	5-6-7-8	3/4	1/4	2.64	740236	1/4 x 2	12-13-14	2	3/8	4.68
740227	3/16 x 1 1/2	9-10-11	1 1/2	1/4	3.00	741540	1/4 x 2 1/2	12-13-14	2 1/2	3/8	5.38
740228	3/16 x 3/4	9-10-11	3/4	1/4	3.00	741541	1/4 x 3/4	15-16-17-18	3/4	7/16	3.76
740229	3/16 x 1	9-10-11	1	1/4	3.00	741542	3/16 x 1	15-16-17-18	1	7/16	3.76
740230	3/16 x 1	9-10-11	1	3/8	3.00	741573	3/16 x 1 3/8	15-16-17-18	1 3/8	1/2	4.32
740231	3/16 x 1 5/8	9-10-11	1 5/8	1/4	3.76	741473	3/16 x 1 1/2	15-16-17-18	1 1/2	7/16	4.50
740232	1/4 x 1 1/2	12-13-14	1 1/2	3/8	3.36	741474	3/16 x 2	15-16-17-18	2	7/16	5.26
700233	1/4 x 3/4	12-13-14	3/4	3/8	3.36						

TOGGLE BOLTS

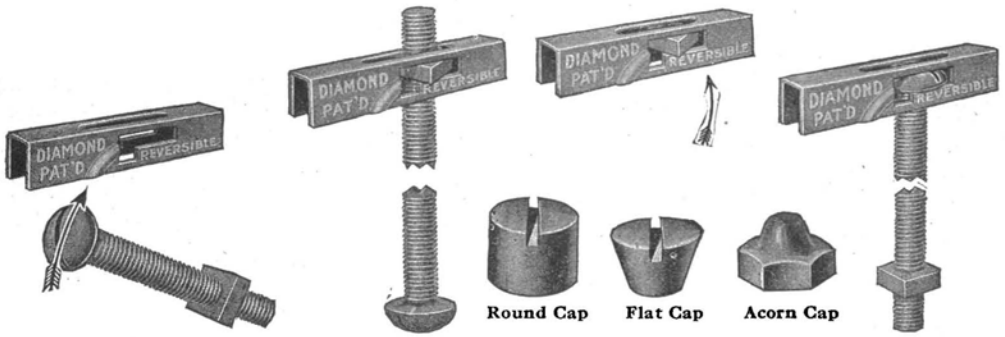

Diamond Reversible Toggle Bolts

They are particularly designed for making quick and permanent fastenings to hollow tile, hollow cement blocks, walls constructed of expanded metal or wood lathes. Can be used with either the finished stove bolt head or the nut exposed or with loose ornamental cap nuts.

**First:** Insert round head of stove bolt through the grooves in sides of toggle and it is ready for use with the nut at the outside of the work.

**Second:** Insert the nut through slot in sides of toggle head and turn the thread of stove bolt into the nut. The toggle is then ready for use with a finished stove bolt head at the outside of the work exposed to view.

**Third:** Diamond toggles are also furnished with long threaded rods as listed below with loose ornamental brass or nickel plated on brass cap nuts, round, flat or acorn.

List Price per Hundred

With Screws	List With Round or Flat Head Stove Bolts		List With Loose Head Plain Brass		List With Loose Head Nickel Plate	
	No.	Price	No.	Price	No.	Price
$\frac{3}{16}$ x 3 ins.	741543	\$4.06	741553	\$4.50	741563	\$5.40
$\frac{3}{16}$ x 3 1/2 ins.	741544	4.24	741554	4.68	741564	5.58
$\frac{3}{16}$ x 4 ins.	741545	4.50	741555	4.86	741565	5.76
$\frac{3}{16}$ x 5 ins.	741546	4.68	741556	5.22	741566	6.12
$\frac{3}{16}$ x 6 ins.	741547	5.14	741557	5.58	741567	6.48
$\frac{1}{4}$ x 3 ins.	741548	5.50	741558	5.94	741568	7.02
$\frac{1}{4}$ x 3 1/2 ins.	741549	5.86	741559	6.30	741569	7.38
$\frac{1}{4}$ x 4 ins.	741550	6.22	741560	6.66	741570	7.74
$\frac{1}{4}$ x 5 ins.	741551	7.12	741561	7.56	741571	8.64
$\frac{1}{4}$ x 6 ins.	741552	7.66	741562	8.64	741572	9.72



Sebco Toggle Bolts

SEBCO NO. 1 TOGGLE

List No.	Size	List Price per 100 With Round or Flat Head Machine Screws
740301	$\frac{3}{16}$ x 3	\$7.50
740302	$\frac{3}{16}$ x 3 1/2	8.00
740303	$\frac{3}{16}$ x 4	8.50
740304	$\frac{3}{16}$ x 5	9.25
740305	$\frac{3}{16}$ x 6	10.00
740306	$\frac{1}{4}$ x 3	8.50
740307	$\frac{1}{4}$ x 3 1/2	9.00
740308	$\frac{1}{4}$ x 4	9.50
740309	$\frac{1}{4}$ x 5	10.25
740310	$\frac{1}{4}$ x 6	11.00

SEBCO NO. 2 TOGGLE

List No.	Size	List Price per 100 With Round or Flat Head Machine Screws
741475	$\frac{3}{16}$ x 3	\$5.20
741476	$\frac{3}{16}$ x 3 1/2	5.50
741477	$\frac{3}{16}$ x 4	5.90
741478	$\frac{3}{16}$ x 4 1/2	6.10
741479	$\frac{3}{16}$ x 5	6.40
741480	$\frac{3}{16}$ x 6	6.90
741481	$\frac{1}{4}$ x 3	5.90
741482	$\frac{1}{4}$ x 3 1/2	6.20
741483	$\frac{1}{4}$ x 4	6.60
741484	$\frac{1}{4}$ x 4 1/2	6.85
741485	$\frac{1}{4}$ x 5	7.10
741486	$\frac{1}{4}$ x 6	7.60

Ajax Toggle Bolts

List No.	Size	List Price per 100	List No.	Size	List Price per 100
740295	$\frac{1}{8}$ x 3 ins.	\$2.88	740298	$\frac{1}{4}$ x 3 ins.	\$3.60
740296	$\frac{1}{8}$ x 4 ins.	3.06	740299	$\frac{1}{4}$ x 4 ins.	3.96
740297	$\frac{1}{8}$ x 6 ins.	3.42	740300	$\frac{1}{4}$ x 6 ins.	4.68

## ANGLE IRON CABLE ARMS

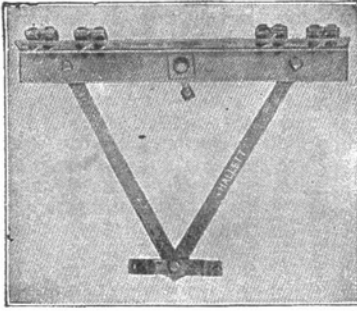

Angle Iron Cable Arm

Can be furnished for supporting 2, 4, 6, and 8 strands. Each arm is complete with strand clamps and a pair of braces.

By counterboring slightly to clear bolt heads, a cross arm may be set in the lap of the angle arm. These strand clamps have heavy steel-forged yokes.

The 6 and 8 strand arms should be gained into the pole about half an inch.

List No.		†List Price Each	
		Plain	Galv.
740336	2 strand arm, complete.....	\$3.96	\$4.72
740337	4 strand arm, complete.....	5.72	5.26
740338	6 strand arm, complete.....	5.46	6.00
740339	8 strand arm, complete.....	6.58	7.50

Galvanized furnished unless otherwise specified.



Guy Shim



Round Washer

## GUY SHIMS

List No.		Weight per 100	*List Price per 100	
			Plain	Galv.
740340	1 x 1/8 x 8 ins.....	38 lbs.	\$4.60	\$7.00
740341	1 1/4 x 1/8 x 8 ins.....	56 lbs.	5.80	9.20

Galvanized furnished unless otherwise ordered.

## ROUND WASHERS

List No.	Diam.	Size of Hole	Thick-ness Wire Gauge	Average No. per 100 Lbs.	*List Price per 1000		List No.	Diam.	Size of Hole	Thick-ness Wire Gauge	Average No. per 100 Lbs.	*List Price per 1000	
					Plain	Galv.						Plain	Galv.
740342	1/8	3/8	16	11,250	\$3.40	\$8.20	740346	1 1/2	5/8	12	2,250	\$9.20	\$19.40
740343	1	7/16	14	6,800	3.40	8.20	740347	1 3/4	1 1/8	10	900	6.14	12.94
740344	1 1/4	1/2	14	4,300	5.00	10.60	740348	2	1 1/8	10	....	8.40	16.68
740345	1 3/8	9/16	12	2,600	5.00	10.60							

When ordering, specify plain or galvanized.

## SQUARE WASHERS



Square Washer

List No.		Weight per 100	*List Price per 1000	
			Plain	Galv.
740350	2 x 2 x 1/8 in., for 1/2 and 5/8 in. bolt.	15 lbs.	17 lbs.	\$9.34 \$16.68
740351	2 1/4 x 2 1/4 x 3/16 in., for 5/8 and 3/4 in. bolt.	25 lbs.	28 lbs.	14.68 26.28
741599	2 1/4 x 2 1/4 x 1/16 in., for 1/2 in. rods.....	25 lbs.	28 lbs.	14.68 26.28
740352	3 x 3 x 3/16 in., for 5/8 and 3/4 in. bolt.	55 lbs.	61 lbs.	31.34 50.00
740353	4 x 4 x 3/16 in., for 5/8 and 3/4 in. bolt.	82 lbs.	90 lbs.	49.34 93.34
740354	5 x 5 x 1/16 in., for 5/8 and 3/4 in. bolt.	130 lbs.	140 lbs.	66.00 124.80

Galvanized furnished unless otherwise ordered.

## HUB OR BUTT PLATES

Are made of 1/8 inch steel bent into a half-circle. This makes a substantial guard, strong enough to stand hard knocks, yet elastic enough so that it can be bent into place on any size pole.

List No.		Weight Each	†List Price Each	
			Painted	Galv.
515	Hub or Butt Plates, 15 x 18 x 1/8 in.....	14 lbs.	\$1.00	\$1.50
516	Hub or Butt Plates, 18 x 20 x 1/8 in.....	19 lbs.	1.34	1.94

Punched for twenty-penny spikes.

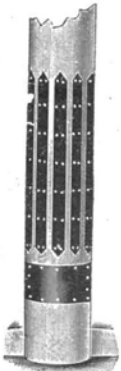

No. 510 & 515-6

## POLE PROTECTION STRIP

Galvanized Steel

List No.		Weight per 100	†List Price	
			per 100	
510	2 in. wide, 4 ft. long, concaved.....			\$16.00

\*Delivery F. O. B. Pittsburgh, Pa. For warehouse deliveries write nearest house.

†Delivery F. O. B. Chicago, Ill. For warehouse deliveries write nearest house.

## STEEL POLE GAINS

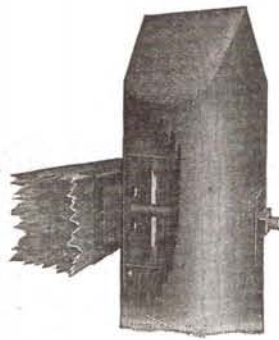

Pole Plate

Steel Gain

This device is a steel support for a cross arm, which saves cutting gains in the pole and obviates the necessity of cross arm braces except on longer than six-pin cross arms. It consists of two pieces, a curved steel plate adapted to embrace the pole, and a steel gain provided with projecting braces or tongues which pass through apertures in the pole plate. The pole plate, when drawn down into place by the bolt, not only conforms closely to the surface of the pole, but draws against the gain, providing sufficient spring tension to compensate for any shrinkage in the pole or cross arm. These gains act as a back brace and will resist a lateral strain, keeping the arm at right angles to the line. They are made of heavy Bessemer steel, and can be furnished either plain or galvanized.

### FOR TELEPHONE USE

### FOR ELECTRIC LIGHT USE

List No.	Gain Plate for Cross Arm	Length of Pole Plate	*List Price Each		List No.	Gain Plate for Cross Arm	Length of Pole Plate	*List Price Each	
			Plain	Galvanized				Plain	Galvanized
740358	3 3/4 ins.	4 ins.	\$0.24	\$0.28	740361	4 1/4 ins.	4 ins.	\$0.24	\$0.28
740359	4 ins.	4 ins.	.24	.28	740362	4 1/4 ins.	8 ins.	.28	.34
740360	4 ins.	8 ins.	.28	.34					

### FOR POWER-TRANSMISSION USE

List No.	Gain Plate for Cross Arm	Length of Pole Plate	*List Price Each		List No.	Gain Plate for Cross Arm	Length of Pole Plate	*List Price Each	
			Plain	Galvanized				Plain	Galvanized
740363	3 3/4 ins.	8 ins.	\$0.40	\$0.52	740368	5 ins.	8 ins.	\$0.44	\$0.58
740364	4 ins.	8 ins.	.42	.54	740369	5 1/4 ins.	8 ins.	.48	.66
740365	4 1/4 ins.	8 ins.	.42	.54	740370	5 1/2 ins.	8 ins.	.52	.70
740366	4 1/2 ins.	8 ins.	.44	.58	740371	5 3/4 ins.	8 ins.	.52	.70
740367	4 3/4 ins.	8 ins.	.44	.58					

\*Delivery F. O. B. Chicago, Ill. For warehouse deliveries, write nearest house.

## ALLEY ARM BRACES

These are made of angle iron, which makes them stiffer and lighter than pipe or rod braces. Made with either forged or straight ends. A step is placed so that the end pins may be conveniently reached. Vertical braces are used to support arms above the bottom one. Galvanized furnished unless otherwise specified.

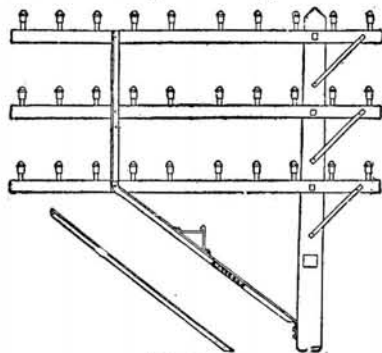

Alley Brace

List No.	Angle Iron Inches	Length Feet	Ends	*List Price per 100 Without Step	
				Plain	Galv.
740372	2 x 2 x 1/4	10	Forged	\$222.50	\$496.00
740373	2 x 2 x 1/4	10	Straight	212.50	478.80
740374	1 3/4 x 1 3/4 x 3/8	7	Forged	118.75	252.00
740375	1 3/4 x 1 3/4 x 3/8	7	Straight	110.00	238.80
740376	1 1/2 x 1 1/2 x 1/2	5	Forged	83.75	156.00
740377	1 1/2 x 1 1/2 x 1/2	5	Straight	76.13	142.80
741591	1 3/4 x 1 3/4 x 3/8	8	Forged	148.75	300.00
741592	1 3/4 x 1 3/4 x 3/8	8	Straight	140.63	287.60
741593	1 3/4 x 1 3/4 x 3/8	9	Forged	180.00	349.00
741594	1 3/4 x 1 3/4 x 3/8	9	Straight	171.25	332.00
741595	1 1/2 x 1 1/2 x 1/2	4	Forged	76.25	142.00
741596	1 1/2 x 1 1/2 x 1/2	4	Straight	70.00	132.00
741597	1 1/2 x 1 1/2 x 1/2	6	Forged	91.25	170.00
741598	1 1/2 x 1 1/2 x 1/2	6	Straight	83.25	156.00

Without step, deduct \$5.00 per 100 Net.

### VERTICAL BRACES

Galvanized 1 1/2 x 1 1/2 x 1/8, 18-inch spacing and 3/16 inch holes unless otherwise specified.

List No.	*List Price per 100	List No.	*List Price per 100		
				Plain	Galv.
740378	2 arm..... \$18.74	26.14	740379	3 arm..... \$30.00	\$46.76

\*Delivery F. O. B. Chicago, Ill. For warehouse deliveries, write nearest house.

## WELDED STEEL EYE BOLTS



Eye Bolt

Fitted with Square Nuts and Washers

PLAIN OR GALVANIZED

Size	Wt. per 100 Pieces	*List Price Each		Size	Wt. per 100 Pieces	*List Price Each		Size	Wt. per 100 Pieces	*List Price Each	
		Plain	Galv.			Plain	Galv.			Plain	Galv.
1/2 x 6	56.7	\$0.18	\$0.24	5/8 x 6	94.9	\$0.23	\$0.30	3/4 x 6	143.0	\$0.31	\$0.42
1/2 x 7	61.8	.19	.25	5/8 x 7	103.1	.24	.31	3/4 x 7	154.9	.33	.43
1/2 x 8	66.9	.20	.26	5/8 x 8	111.3	.24	.32	3/4 x 8	166.8	.34	.45
1/2 x 9	72.0	.20	.27	5/8 x 9	119.5	.25	.34	3/4 x 9	178.7	.35	.48
1/2 x 10	77.1	.21	.28	5/8 x 10	127.7	.26	.35	3/4 x 10	190.6	.37	.49
1/2 x 11	82.2	.22	.29	5/8 x 11	135.9	.27	.36	3/4 x 11	202.5	.38	.50
1/2 x 12	87.3	.22	.29	5/8 x 12	144.1	.28	.37	3/4 x 12	214.4	.39	.52
1/2 x 13	92.4	.23	.30	5/8 x 13	152.3	.29	.39	3/4 x 13	226.3	.40	.54
1/2 x 14	97.5	.24	.31	5/8 x 14	160.5	.30	.40	3/4 x 14	238.2	.42	.56
1/2 x 15	102.6	.24	.32	5/8 x 15	168.7	.31	.41	3/4 x 15	250.1	.43	.57
1/2 x 16	107.7	.25	.33	5/8 x 16	176.9	.32	.42	3/4 x 16	262.0	.44	.59

## GROUND RODS



Ground Rod

Size	Lbs. per 100 Plain and Galv.	*List Price per 100	
		Plain	Galv.
3/8 in. x 5 ft., without ground wire.....	181	\$14.68	\$22.68
3/8 in. x 6 ft., without ground wire.....	218	16.94	26.68
1/2 in. x 6 ft., without ground wire.....	319	25.88	38.68
1/2 in. x 7 ft., without ground wire.....	394	29.62	45.06
5/8 in. x 6 ft., without ground wire.....	600	38.42	62.68
5/8 in. x 8 ft., without ground wire.....	800	44.00	72.54
1/2 in. x 5 ft., with ground wire.....	322	37.34	50.66
1/2 in. x 6 ft., with ground wire.....	388	41.08	57.08
5/8 in. x 6 ft., with ground wire.....	605	52.00	58.28

## PARAGON GROUND CONES



Ground Cone

Are made of a perforated sheet of pure copper; cone is filled with pea-sized charcoal or coke; the charcoal absorbs moisture by keeping the earth around the cone always moist, insuring a permanent and perfect ground.

For telephone, telegraph, railroad, and trolley work it is ideal for grounding lightning arresters of all kinds, pole, cable, terminals, distributing, and protector frames, and all line arresters.

The cone is furnished complete with charcoal, and with braided hollow copper cable of 61,968 cm. cross-section, into which the ground wire may be soldered. The cable is securely soldered to the bottom of the cone.

List No.		Length	B. & S. Gauge	†List Price Each
1	For telephone and telegraph.....	1 ft.	25	\$3.30
2	For telephone and telegraph.....	2 ft.	25	4.80
3	For electric light.....	1 ft.	21	3.90
4	For electric light.....	2 ft.	21	5.40

\*Delivery F. O. B. Pittsburgh. †Delivery F. O. B. Chicago, Ill. For warehouse deliveries write nearest house.

**CABLE HANGERS**

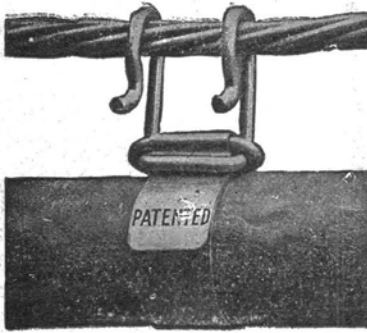

**Boston Cable Clip**

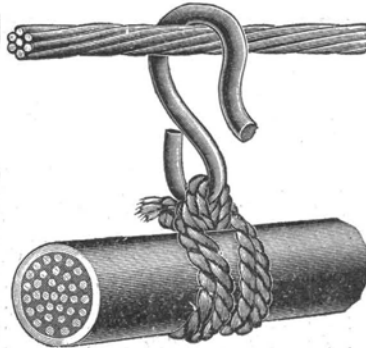

**Marlin Cable Hanger**

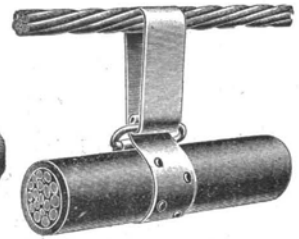

**Metropolitan Cable Clip  
Type A**

**Boston Cable Clip**

Furnished with two sizes of Hooks

No. 1 for 1/4 inch Messenger Wire; No. 4 for 1/2 inch Messenger Wire

List No.	Mfr No.	Length of Strap	Hook No.	*List Price	
				Per 100	Per 1000
740569	1	6 ins.	1	\$7.60	\$64.00
740570	2	7 ins.	1	7.60	64.00
740571	3	8 ins.	1	7.60	64.00
740572	4	6 1/2 ins.	4	7.60	64.00
740573	5	6 1/2 ins.	1	7.60	64.00

**Marlin Cable Hanger**

**No. 1 Grade**

No. 1 grade is an excellent hanger, quality of hemp not quite as good as No. 3. Hooks are made from No. 9 galvanized steel wire.

List No.	Size	Length of Loop	Hook No.	Material	Weight Per 1000	†List Price per 1000
740574	25 pair	9 ins.	9	2-ply Marlin	30 lbs.	\$14.18
740575	50 pair	11 ins.	9	2-ply Marlin	33 lbs.	14.86
740576	75 pair	12 ins.	9	2-ply Marlin	34 lbs.	15.56
740577	100 pair	14 ins.	9	3-ply Houseline	40 lbs.	17.48
740578	150 pair	15 ins.	9	3-ply Houseline	42 lbs.	18.58
740579	200 pair	16 ins.	9	3-ply Houseline	44 lbs.	19.40

**No. 3 Grade**

No. 3 Grade Marlin Cable Hanger is made in accordance with A. T. & T. Co.'s specifications. The marlin used is 3-ply and is made of the finest quality of selected long line American hemp. The hooks are of No. 9 wire, galvanized by hot dip process after they are formed.

List No.	Size	Length of Loop	Hook No.	Material	Weight Per 1000	†List Price per 1000
740580	25 pair	9 ins.	9	3-ply Houseline	35 lbs.	\$18.86
740581	50 pair	11 ins.	9	3-ply Houseline	37 lbs.	20.50
740582	75 pair	12 ins.	9	3-ply Houseline	38 lbs.	21.32
740583	100 pair	14 ins.	9	3-ply Houseline	40 lbs.	22.98
740584	150 pair	15 ins.	9	3-ply Houseline	42 lbs.	23.80
740585	200 pair	16 ins.	9	3-ply Houseline	45 lbs.	24.62

**Metropolitan Cable Clip**

Will stand 400 lbs. strain. The steel wire loop is heavily galvanized and the band which encircles both cable and supporting strand is of zinc.

List No.	Type A	*List Price per 1000	List No.	Type B	*List Price per 1000
741783	8 inches	66.00	741785	9 inches	66.00
741784	9 inches	72.00			

\*Delivery F. O. B. Boston, Mass. †Delivery F. O. B. Cleveland, O. For warehouse deliveries, write nearest house.

**AERIAL CABLE RINGS**



Type "A"



Type "B"



Type "C"



Type "D"

Made of steel heavily and smoothly galvanized after forming. They are placed on the strand by a line-man, seated in a cable car or boatswain's chair.

A tool called a crimping plier is used to fasten them to the strand and the cable is then pulled into the suspended rings.

The inside diameter of ring should be from 1/2 to 3/4 inch greater than the outside diameter of cable to be installed.

List No.	Size, Inches Inside Diameter	*List Price		List No.	Size, Inches Inside Diameter	*List Price	
		Per 100	Per 1000			Per 100	Per 1000
740969	1 3/4 in. Type A Cable Rings	\$1.80	\$12.00	740972	2 1/2 in. Type C and D Cable Rings	\$2.70	\$18.00
740970	1 3/4 in. Type B Cable Rings	1.95	13.00	740973	3 in. Type C and D Cable Rings	3.00	20.00
740971	2 in. Type C and D Cable Rings	2.33	15.50	740974	3 1/2 in. Type C and D Cable Rings	3.60	24.00



Combination

Cable

\*Delivery F. O. B. Boston, Mass. write nearest house.

**PEIRCE CABLE RINGS**

**CABLE**

Width of strap, 1/2 inch; diameter of eye, 1 3/4 inch

List No.	Description	*List Price per 100		
		Weight per 100	Without Bolt	With Bolt
740156	Peirce Cable Ring	15 3/4 lbs.	\$2.98	\$6.24

**COMBINATION**

Width of strap, 5/8 inch; diameter of eye, 1 3/4 inch

List No.	Description	*List Price per 100		
		Weight per 100	Without Bolt	With Bolt
740157	Combination Cable Ring	11 lbs.	\$4.20	\$7.46

†Delivery F. O. B. Pittsburgh, Pa. For warehouse deliveries

**POLE BANDS**



Pole Band, 2-Bolt



Pole Band, 3-Bolt

List No.	Solid Band for	Approx. Wt. Lbs. †List Price		List No.	Split Band for	Approx. Wt. Lbs. †List Price	
		per 100	per 100			per 100	per 100
741575	4 in. pole, single bolt	155	\$23.74	741583	4 in. pole, two bolt	200	\$26.26
741576	5 in. pole, single bolt	180	26.26	741584	5 in. pole, two bolt	225	28.74
741577	6 in. pole, single bolt	210	28.74	741585	6 in. pole, two bolt	235	31.26
741578	7 in. pole, single bolt	230	31.26	741586	7 in. pole, two bolt	275	33.74
741579	4 in. pole, two bolt	200	26.26	741587	4 in. pole, three bolt	275	28.74
741580	5 in. pole, two bolt	225	28.74	741588	5 in. pole, three bolt	313	31.26
741581	6 in. pole, two bolt	250	31.26	741589	6 in. pole, three bolt	330	33.74
741582	7 in. pole, two bolt	275	33.74	741590	7 in. pole, three bolt	338	36.26

†F. O. B. Factory, Newark, N. J. For warehouse deliveries, write nearest house.

CONSTRUCTION MATERIAL

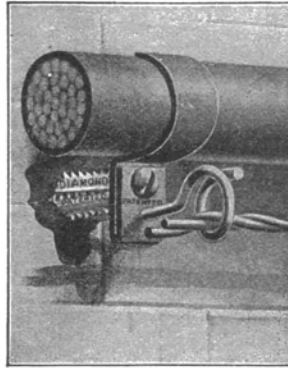

Cable Clamp

“Long-Saut” Combination Cable Clamp

For attaching telephone cables and bridle wires with one fastening to brick or wood buildings, fences, etc.

List No.	No.	Outside Diam. of Cables	*List Price per 100	List No.	No.	Outside Diam. of Cables	*List Price per 100
740158	00000	$\frac{3}{8}$	\$1.86	740165	2	$1\frac{1}{8}$	\$6.52
740159	0000	$\frac{1}{8}$	2.14	740166	3A	$1\frac{1}{4}$	7.66
740160	000	$\frac{1}{2}$	2.26	740167	3	$1\frac{1}{2}$	7.66
740161	00	$\frac{5}{8}$	2.52	740168	4A	$1\frac{3}{4}$	8.02
740162	0	$1\frac{1}{8}$	5.02	740169	4	2	8.02
740163	1	$\frac{3}{4}$	5.64	740170	5	$2\frac{5}{8}$	15.00
740164	2A	1	6.38				

Bridle Rings with Machine Threads to Fit Clamps

Sold Separately

List No.	Size	No. 10 Wire.	Eye	*List per 100—	
				Brass	Galvanized
741498	Size K	No. 10 Wire.	$\frac{3}{4}$ in. eye.	\$4.50	\$3.00
741499	Size M	No. 10 Wire.	$1\frac{1}{4}$ in. eye.	5.78	4.96

Diamond Expansion Shields or Screw Anchors to Attach Clamps

For Nos. 4-0, 3-0 and 2-0 use  $\frac{3}{16}$  x 1 inch anchors, with No. 10 x 1 inch R. H. galvanized wood screws.

For Nos. 0, 1, 2 and 2A use  $\frac{1}{4}$  x 1 inch anchors, with No. 14 x  $1\frac{1}{4}$  inch R. H. galvanized wood screws.

For Nos. 3A, 3, 4A, 4 and 5 use  $\frac{1}{4}$  x  $1\frac{1}{2}$  inch anchors, with No. 14 x  $1\frac{3}{4}$  inch R. H. galvanized wood screws.



Bridle Ring

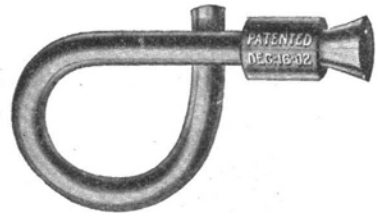

Expansion Ring Bolt

Bridle Rings

Are for the carriage and distribution of wires. Due to the superior process of enameling, no chafing of the wires, absolute smoothness, perfect insulation, and proof against rust are points of distinction.

List No.	Mfr. No. Style	Inside Diam. of Eye	Width of Opening	Length of Stem Under Ring	Std. Pkg.	*List Price per 1000—	
						Enamel	Galvanized
740171	A	$1\frac{5}{8}$	$\frac{5}{16}$	$1\frac{1}{4}$	500	\$66.12	\$32.78
740172	C	$1\frac{1}{4}$	$\frac{1}{8}$	$1\frac{1}{4}$	500	58.90	28.04
740173	E	$\frac{5}{8}$	$\frac{1}{8}$	$\frac{7}{8}$	1000	42.76	12.84
740174	F	3	$\frac{1}{8}$	$1\frac{1}{4}$	Assorted	131.10	87.40

Enamelled furnished unless otherwise ordered.

Peirce Expansion Ring Bolts

List No.	Size	*List Price per 100	List No.	Size	*List Price per 100
740178	$\frac{3}{4}$ in. size.	\$4.54	740180	$1\frac{1}{4}$ in. size.	\$5.72
740179	1 in. size.	5.18	740181	$1\frac{3}{4}$ in. size.	6.66

Ring bolt requires  $\frac{1}{2}$  inch hole, 1 inch deep.

\*Delivery F. O. B. New York. †Delivery F. O. B. Pittsburgh, Pa. For warehouse deliveries write nearest house.

CABLE SPLICING JOINTS

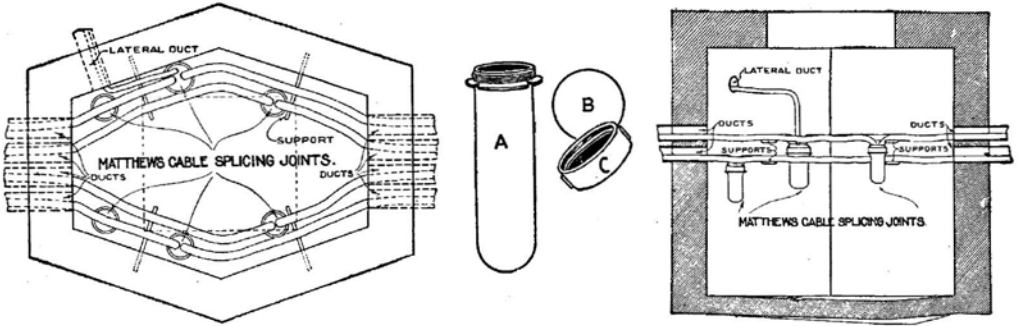

This device is designed to take the place of horizontal splices in multiconductor lead-covered cables, and is adapted particularly for underground manholes. The joint consists of three parts as shown in the illustration: "A," lead pot or sleeve, which is lined with galvanized iron to insure stability, and sweated to a threaded brass ring; "B," brass collar internally threaded to fit ring and tinned on upper edges; "C," lead gasket through which cables pass. In attaching, the cables are "wiped in" and the lead sleeve is screwed into the brass collar "C" by means of the spanner wrenches. The threads of ring "A" are well coated with red lead before screwing into collar "C." The completed splice is absolutely moistureproof, and is readily accessible for line tests or change in multiples. Any lineman can learn to make an absolutely moisture-proof cable joint after an hour's practice on the directions that are furnished with them, avoiding delay in case skilled cable splicers are not obtainable.

List No.	Mir. No.	Description	List Price Each			Net Additions for Delivery on Pacific Coast
			Less than 25	25 to 49	50 or more	
740594	1	Will take for straightaway splice any cable up to and including 1 inch, outside diameter, for each cable..... Weight, 3 lbs., inside dimensions, 2¼ x 8 inches.	\$4.80	\$4.56	\$4.40	\$0.06
740595	2	Will take for straightaway splice any cable up to and including 1½ inches, outside diameter, for each cable..... Weight, 4 lbs., inside dimensions, 3¼ x 8 inches.	6.00	5.70	5.50	.08
740596	3	Will take for straightaway splice any cable up to and including 2⅛ inches, outside diameter, for each cable..... Weight, 7½ lbs., inside dimensions, 4⅜ x 9 inches.	9.60	9.12	8.80	.15
740597	4	Will take for straightaway splice any cable up to and including 2¾ inches, outside diameter, for each cable..... Weight, 15 lbs., inside dimensions, 5¾ x 11⅞ inches.	15.00	14.24	13.74	.30

SPANNER WRENCHES

List No.	For Joint No.	Description	List Price Each	Net Additions for Delivery on Pacific Coast
740598	1	Wrench only.....	\$1.00	\$0.02
740599	2	Wrench only.....	1.10	.02
740600	3	Wrench only.....	1.50	.04
740601	4	Wrench only.....	1.80	.08

Spanner Wrenches will only fit the joint for which they are made. Quantities may consist of an assortment of various sizes of joints.

## POLE SEATS AND PLATFORMS

Hot Galvanized or Painted

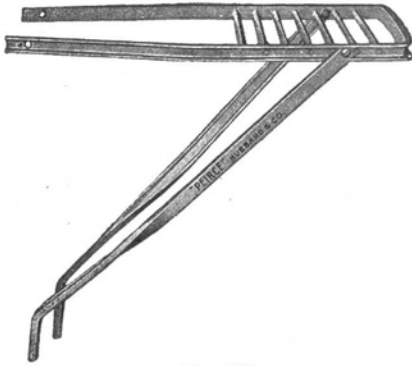

No. 755

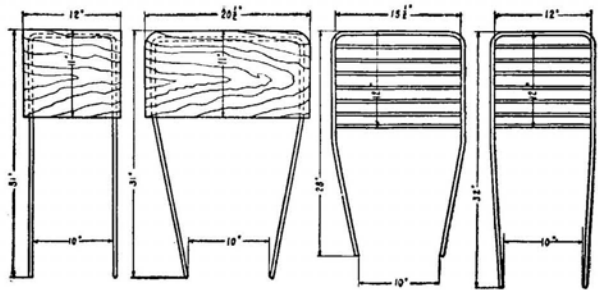

Pole Seats

### Peirce Pole Seats

These seats in a competitive test held a dead load of 1740 lbs. without deflection. A 1 1/4 inch angle iron seat, weighing fifty per cent. more, collapsed with 960 lbs. load. The frames and braces of all styles are of 1 x 1/2 inch channel steel. The wood seats are 1 1/4 inch cypress, boiled in creosote. The bars of the all steel seats are 3/8 inch square steel let into the frame in such manner as to leave no projecting ends. There is no strain on the riveted joints. The bars are placed with corners up, to prevent slipping. They are shipped completely assembled in bundles of five.

List No.	Old No. and Style	Std. Bundle	Weight per 100 Lbs.	*List Price Each
750	No. 1, painted Pole Seat . . . . .	5	1260	\$1.70
751	No. 1, galvanized Pole Seat . . . . .	5	1260	2.00
752	No. 2, painted Pole Seat . . . . .	5	1400	2.50
753	No. 2, galvanized Pole Seat . . . . .	5	1400	2.90
754	No. 3, painted Pole Seat . . . . .	5	1400	1.90
755	No. 3, galvanized Pole Seat . . . . .	5	1400	2.40
756	No. 4, painted Pole Seat . . . . .	5	1260	1.90
757	No. 4, galvanized Pole Seat . . . . .	5	1260	2.40

\*Delivery F. O. B. Pittsburgh, Pa. For warehouse deliveries write nearest house.

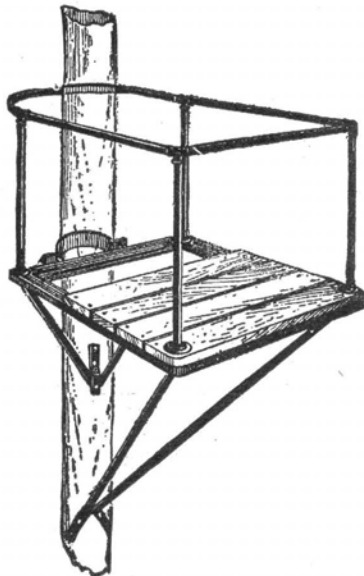

Pole Platform

Telephone Apparatus and Supplies

### Pole Platform

SECURITY TYPE

This type is intended for important points, and is therefore built strong in order to support several men at once. The guard rails go around the pole and fasten to it by lags. This makes the rail very staunch. For shipment, the platform and rail are wired to each other. All the braces, post, and lag screws are boxed and are complete. The dimensions of frame over all are 32 x 32 inches and wood floor is 27 x 32 inches.

List No.		Approximate Weight	†List Price Each
740563	Pole Platform, with railing . . . . .	90 lbs.	\$29.00
740564	Pole Platform, without railing . . . . .	62 lbs.	24.50

†Delivery F. O. B. Toledo, O. For warehouse deliveries write nearest house.

**DISTRIBUTING RACKS AND KNOB FIXTURES**

Hot Galvanized



No. 2900



No. 2901



No. 2902



No. 2910

**Peirce Distributing Racks**

For Telephone Wires

These racks furnish a secure but inexpensive means for distributing twisted pair telephone wires to cable poles. Numbers 2900, 2901 and 2902 are made with 1 3/4 inch channel steel back, pressed steel eyes and 3/8 inch through bolts.

List No.	Mfr. No.	Pair Wires	Frame	Wt. Lbs. per 100	*List Price	
					Each	Lots 25
741233	2900	4	Channel Single	225	\$0.76	\$16.50
741234	2901	6	Channel Single	300	1.00	21.50
741235	2902	8	Channel Single	475	1.24	27.00
741236	2910†	5	Malleable Single	350	1.86	40.00
741237	2911	8	Malleable Single	400	2.30	50.00
741238	2912	10	Malleable Double	515	2.88	62.00
741239	2913	16	Malleable Double	615	4.06	87.50

†The cut shows a 4 instead of a 5 knob rack through error. All prices are for racks complete with knobs.



No. 2920



No. 2922



No. 2924

**Peirce Single Knob Fixtures**

These small fixtures are for either telephone or lighting wires, but for the latter they should only be used in localities not visited by snow or sleet. No. 2922 fixture can be fastened to wood building with a screw in the center hole, and to brick buildings with a Peirce Expansion Bolt, making a strong fastening and one which is especially adapted to duplex service wires. No. 2924 is a redesign of the Peirce Knob Screw, in which the shank is lengthened to 2 1/2 inches.

List No.	Mfr. No.		Wt. Lbs. per 100	*List Price	
				Each	Per 100
741240	2920	Single Knob Fixture.....	35	\$0.12	\$9.60
741241	2922	Single Knob Fixture.....	48	.17	14.40
741242	2924	Single Knob Fixture.....	40	.14	12.00

All prices complete with knobs.

\*F. O. B. Factory, Pittsburgh, Pa. For warehouse deliveries, write nearest house.

PLAIN AND INSULATED TURNBUCKLES

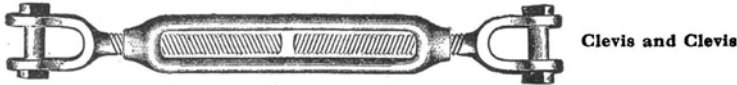
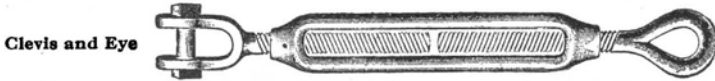
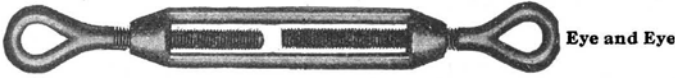
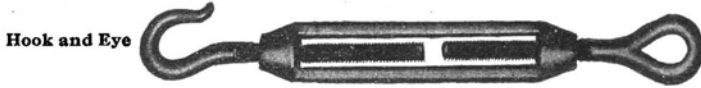

Plain Turnbuckles

Size	Hook and Eye		Eye and Eye		Clevs and Eye		Clevs and Clevs	
	List No.	*List Price	List No.	*List Price	List No.	*List Price	List No.	*List Price
$\frac{3}{8}$ x $2\frac{7}{8}$	741285	\$0.47	741312	\$0.47	741339	\$0.64	741366	\$0.77
$\frac{1}{4}$ x $3\frac{7}{8}$	741286	.49	741313	.49	741340	.71	741367	.84
$\frac{3}{8}$ x $4\frac{1}{4}$	741287	.49	741314	.52	741341	.77	741368	.96
$\frac{3}{8}$ x $4\frac{1}{2}$	741288	.58	741315	.58	741342	.84	741369	1.09
$\frac{3}{8}$ x 9	741289	.87	741315	.91	741343	1.16	741370	1.35
$\frac{3}{8}$ x 12	741290	.98	741317	1.04	741344	1.22	741371	1.41
$\frac{1}{2}$ x 5	741291	.65	741318	.65	741345	1.03	741372	1.28
$\frac{1}{2}$ x 6	741292	.81	741319	.81	741346	1.22	741373	1.48
$\frac{1}{2}$ x 9	741293	1.01	741320	1.01	741347	1.54	741374	1.80
$\frac{1}{2}$ x 12	741294	1.30	741321	1.30	741348	1.67	741375	1.92
$\frac{9}{16}$ x 6	741295	.98	741322	1.10	741349	1.48	741376	1.73
$\frac{9}{16}$ x 9	741296	1.27	741323	1.33	741350	1.80	741377	2.05
$\frac{9}{16}$ x 12	741297	1.39	741324	1.44	741351	1.86	741378	2.18
$\frac{5}{8}$ x 6	741298	1.01	741325	1.39	741352	1.73	741379	1.99
$\frac{5}{8}$ x 9	741299	1.30	741326	1.30	741353	1.99	741380	2.31
$\frac{5}{8}$ x 12	741300	1.59	741327	1.59	741354	2.05	741381	2.37
$\frac{3}{4}$ x 6	741301	1.39	741328	1.39	741355	2.18	741382	2.69
$\frac{3}{4}$ x 9	741302	1.59	741329	1.59	741356	2.50	741383	3.01
$\frac{3}{4}$ x 12	741303	1.88	741330	1.88	741357	2.69	741384	3.14
$\frac{7}{8}$ x 6	741304	1.73	741331	1.73	741358	2.95	741385	3.97
$\frac{7}{8}$ x 9	741305	2.16	741332	2.16	741359	3.52	741386	4.48
$\frac{7}{8}$ x 12	741306	2.45	741333	2.45	741360	3.72	741387	4.61
1 x 6	741307	2.02	741334	2.02	741361	3.52	741388	4.55
1 x 9	741308	2.60	741335	2.60	741362	4.16	741389	5.06
1 x 12	741309	3.03	741336	3.03	741363	4.36	741390	5.32
$1\frac{1}{8}$ x 12	741310	3.75	741337	3.91	741364	5.76	741391	7.04
$1\frac{1}{4}$ x 12	741311	5.64	741338	4.58	741365	7.68	741392	8.64



Insulated Turnbuckles

List No.	Test Load in Lbs.	Average Breaking Load in Lbs.	Max. Takeup in Ins.	Diam. Bolt in Ins.	Max. Length Between Centers of Eyes in Ins.	Approx. Net Wt. per 100	†List Price per 100
740541	3000	6000	6	$\frac{1}{2}$	$18\frac{3}{4}$	275 lbs.	\$100.00
740542	4000	8000	$6\frac{3}{16}$	$\frac{5}{8}$	$18\frac{3}{4}$	325 lbs.	135.00
740543	3000	6000	12	$\frac{1}{2}$	$29\frac{3}{4}$	325 lbs.	150.00
740544	4000	8000	$12\frac{3}{16}$	$\frac{5}{8}$	30	410 lbs.	200.00

\*Delivery F. O. B. South Portland, Me. †Delivery F. O. B. Schenectady, N. Y. For warehouse deliveries write nearest house.

FIBER CONDUIT

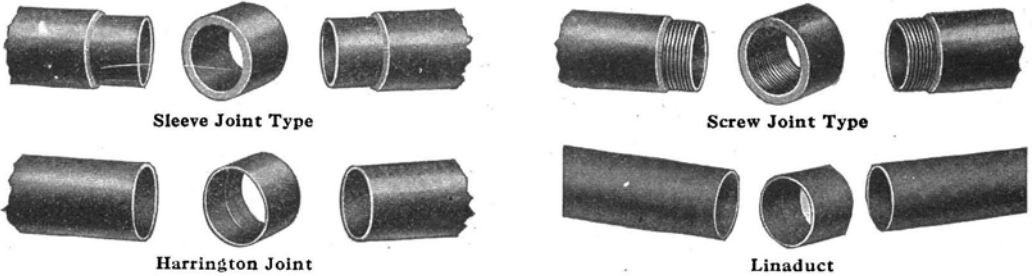

In the process of manufacturing fiber conduit, wet wood pulp or fiber is wrapped in a minutely thin film upon a forming mandrel, under pressure, until the desired thickness of wall is obtained. The individual fibers become felted and form a solid homogeneous wall. Taken off the mandrel, the wet pulp structure is subjected to a drying process, after which it is placed in a vat of liquid compound. This compound is a preservative and is also insulating and waterproofing. It thoroughly permeates the entire structure so that after treatment the wall of the conduit, when cut, presents a strong resemblance to hard rubber. The ends are cut in a lathe to make a socket joint, sleeve joint, or screw thread, as may be desired.

THE SLEEVE JOINT TYPE

The ends of each length are turned down to fit snugly in a sleeve by means of which a tight connection is made. The ends of the pipe are squared and faced.

List No.	Inside Dia., Ins.	Thickness of Wall, Ins.	Wt. per Ft., Lbs.	‡List Price per Ft.†	List No.	Inside Dia., Ins.	Thickness of Wall, Ins.	Wt. per Ft., Lbs.	‡List Price per Ft.†
740062	*1	1/4	0.40	\$0.22	740066	3	1/4	1.30	\$0.20
740063	1 1/2	1/4	0.74	.17	740067	3 1/2	7/16	2.50	.29
740064	2	1/4	0.90	.17	740068	4	1/2	3.20	.36
740065	2 1/2	1/4	1.10	.18					

HARRINGTON JOINT TYPE

This type of joint is a modification of our sleeve joint and is made with a tapered end. Sleeves are tapered also, thereby allowing more swing to the conduit than can be secured by other types of joints. In this type the conduit does not butt, in consequence of which more flexibility may be had.

List No.	Inside Dia., Ins.	Thickness of Wall, Ins.	Wt. per Ft., Lbs.	‡List Price per Ft.†	List No.	Inside Dia., Ins.	Thickness of Wall, Ins.	Wt. per Ft., Lbs.	‡List Price per Ft.†
740069	2	1/4	0.90	\$0.16	740072	3 1/2	1/4	1.55	\$0.20
740070	2 1/2	1/4	1.10	.17	740073	4	1/4	1.90	.22
740071	3	1/4	1.30	.18					

THE SCREW JOINT TYPE

This type of fiber conduit is manufactured with a slightly thicker wall than the socket joint type, owing to the necessity of securing a sufficiently heavy structure for carrying the thread that is cut on the ends of the pipe. The thread is "United States Standard"—four to the inch—and a coupling is provided for completing the joint. A liquid compound is furnished by the manufacturer to be wiped on the threads of the pipe when making the connection. This compound hardens and renders the joint watertight.

List No.	Inside Dia., Ins.	Thickness of Wall, Ins.	Wt. per Ft., Lbs.	‡List Price per Ft.†	List No.	Inside Dia., Ins.	Thickness of Wall, Ins.	Wt. per Ft., Lbs.	‡List Price per Ft.†
740074	*1 1/2	5/8	0.85	\$0.24	740077	3	7/16	2.20	\$0.34
740075	2	3/8	1.32	.27	740078	3 1/2	7/16	2.50	.39
740076	2 1/2	3/8	1.65	.27	740079	4	1/2	3.20	.48

"LINADUCT"

"Linaduct" is designed as a form and insulating lining for concrete subways. This type of fiber conduit is made in five-foot lengths, diameters 2 to 3 1/2 inches, 1/8 inch walls. The sections are joined by a close fitting sleeve, quickly and easily adjusted to give good alignment and a sufficiently tight joint for the exclusion of concrete.

List No.	Inside Dia., Ins.	Thickness of Wall, Ins.	Wt. per Ft., Lbs.	‡List Price per Ft.†	List No.	Inside Dia., Ins.	Thickness of Wall, Ins.	Wt. per Ft., Lbs.	‡List Price per Ft.†
740080	2	1/8	0.55	\$0.17	740082	3	1/8	0.75	\$0.12
740081	*2 1/2	1/8	0.65	.12	740083	3 1/2	1/8	0.85	.14

\*Manufactured only on special order. †Includes one coupling to each length.  
‡Delivery F. O. B. Orangeburg, N. Y. For warehouse deliveries write nearest house.

FIBER CONDUIT (Cont'd.)



Fiber Conduit

THE SOCKET JOINT TYPE

Socket or mortise and tenon connections are automatically turned on the ends of each length, being 3/8 inch long, slightly tapering, and uniform in size. This connection secures laying the conduit perfect in fit and alignment.

List No.	Inside Dia., Ins.	Thickness of Wall, Ins.	Wt. per Ft., Lbs.	‡List Price per Ft.	List No.	Inside Dia., Ins.	Thickness of Wall, Ins.	Wt. per Ft., Lbs.	‡List Price per Ft.
740084	*1	1/4	0.38	\$0.15	740088	3	1/4	1.20	\$0.15
740085	1 1/2	1/4	0.70	.12	740089	3 1/2	1/4	1.45	.16
740086	2	1/4	0.85	.12	740090	4	1/4	1.62	.18
740087	2 1/2	1/4	1.02	.14					

\*Manufactured only on special order.

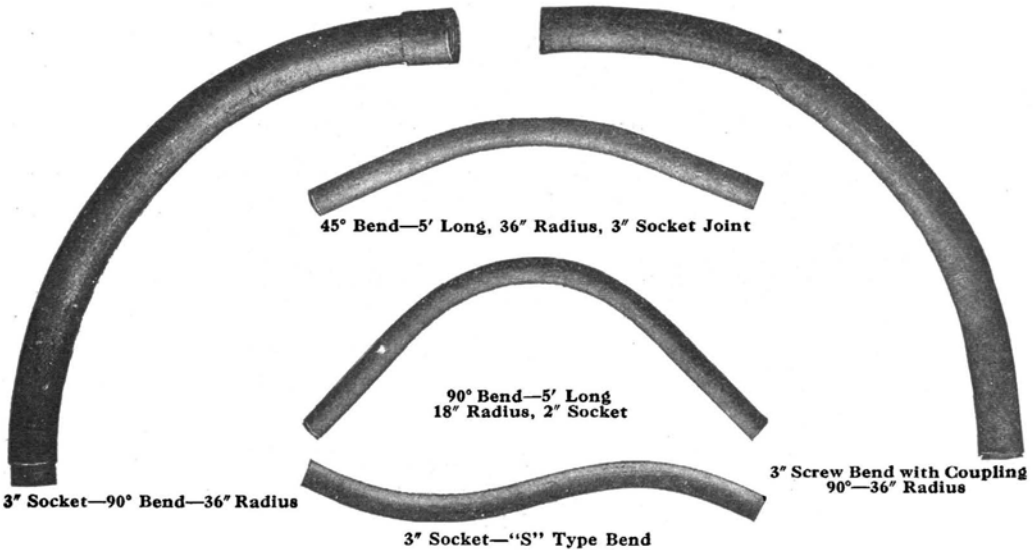

Fiber Conduit Bends

In producing these bends the conduit is first formed in the usual manner. When the wet pulp structure is removed from the mandrel it is bent on a special form to the radius and degree desired, after which it is dried and thoroughly saturated with an insulating and preservative compound. Special bends of short radii are mitered to give the degree and radii desired.

STANDARD BENDS

Inside diameter, ins. ....	1	1 1/2	2	2 1/2	3	3 1/2	4
----------------------------	---	-------	---	-------	---	-------	---

Data, 45° and 90° Bends

Length, feet. ....	2 1/2	5	5	5	5	5	5
Radius, ins. ....	18	18-24-36	18-24-36	24-36	36	36	36

Data, "S" Bends

Offset, ins. ....	10	20	20	20	20	20	20
Radius, ins. ....	8	36	36	36	36	36	36

\*List Price Each

Socket. ....	\$1.80	\$2.04	\$2.04	\$2.10	\$2.16	\$2.40	\$2.70
*Sleeve. ....	1.98	2.28	2.28	2.40	2.52	4.62	5.58
*Harrington. ....			2.28	2.40	2.52	2.76	3.12
*Screw. ....		3.72	3.84	3.84	4.20	4.68	5.64
†Linaduct. ....			2.10	2.16	2.28	2.52	.....

\*Price includes couplings. †1/4 inch wall.

‡Delivery F. O. B. Orangeburg, N. Y. For warehouse deliveries write nearest house.

## FIBER CONDUIT FITTINGS



### Fiber Fittings

These fittings are made throughout of the same material as is used in the manufacture of fiber conduit and possess the same extremely high insulating qualities of that conduit.

In making these fittings the conduit is first formed and dried in the usual manner. It is then shaped into different forms of fittings, after which it is thoroughly saturated with the insulating and preservative compound.

Joints are then cut in a lathe to make a socket, sleeve or screw connection.

Inside diameter, ins. ....	†List Price Each						
	1	1½	2	2½	3	3½	4
<b>COUPLINGS</b>							
Sleeve .....	\$0.11	\$0.11	\$0.12	\$0.15	\$0.17	\$0.27	\$0.34
Harrington .....			.12	.14	.15	.17	.20
Screw .....		.15	.17	.20	.22	.29	.36
Rough fit for socket .....		.09	.10	.11	.12	.14	.15
<b>CAPS OR PLUGS</b>							
Socket .....	\$0.32	\$0.32	\$0.34	\$0.36	\$0.41	\$0.48	\$0.60
Sleeve .....	.32	.32	.34	.36	.41	.48	.60
Screw .....		.36	.39	.41	.45	.51	.63
<b>REDUCERS Largest End</b>							
Socket .....		\$0.48	\$0.51	\$0.56	\$0.60	\$0.68	\$0.75
Sleeve .....		.51	.53	.58	.63	.70	.77
Harrington .....		.51	.53	.58	.63	.68	.75
Screw .....		.53	.56	.60	.65	.72	.80
<b>CROSSES</b>							
*All types .....	\$3.42	\$3.54	\$3.66	\$3.78	\$3.90	\$4.14	\$4.68
<b>TEES</b>							
Socket .....	\$2.16	\$1.98	\$1.98	\$2.10	\$2.16	\$2.34	\$2.70
*Sleeve .....	2.58	2.40	2.40	2.52	2.64	3.06	3.48
*Harrington .....			2.40	2.52	2.64	2.82	3.24
*Screw .....		2.64	2.76	2.82	2.94	3.12	3.54
<b>ELBOWS</b>							
Socket .....	\$1.44	\$1.32	\$1.32	\$1.38	\$1.44	\$1.56	\$1.80
*Sleeve .....	1.68	1.56	1.56	1.62	1.68	1.92	2.16
*Harrington .....			1.56	1.62	1.68	1.80	2.04
*Screw .....		1.612	1.74	1.80	1.86	1.98	2.22

\*Price includes couplings.



### Junction Boxes

Fiber Junction Boxes can be used with either screw, sleeve or socket joint conduit. They are especially recommended for service connections and where it is necessary to light up private roads. These boxes are made two, three and four way. The inside dimensions are, approximately, 8 x 8 inches, and the weight is 16 pounds.

List No.		†List Price Each
741706	Junction Box, one to four openings .....	\$7.92

Always specify number of openings wanted, and type of conduit with which junction box is to be used.  
 †Delivery F. O. B. Orangeburg, N. Y. For warehouse deliveries, write nearest house.

## VITRIFIED CLAY CONDUIT

This conduit is made of the purest fire-clay, salt glazed, and guaranteed to comply rigidly with the American Telephone and Telegraph Company's specifications. We inspect all conduit as it is loaded. Conduit is manufactured in all standard sizes and designs, and includes some special economic forms.

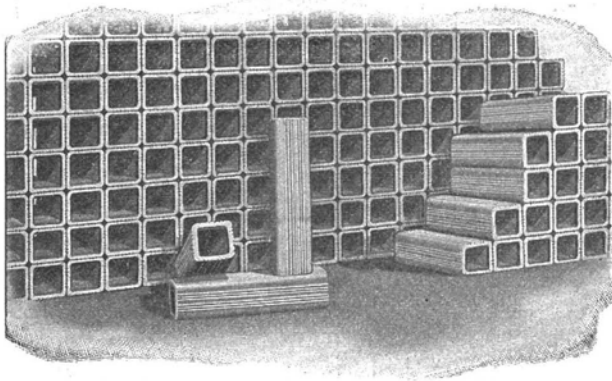

### Single-Way Conduit

**Single Duct Conduit:** May be obtained in either of two forms: the square or round duct. The square duct single is heavier and has no real advantage over the round duct single. The round duct is now the popular single duct conduit. Its weight is much less, thus saving on freight. It is especially efficient in building up trunk lines, the beveled corners allowing square interstices between the pieces, thus forming an additional concrete support, and insuring good alignment before and after cable pulling.

### 2-Way and 3-Way Multiple Conduit

**Two-way and Three-way Multiple Conduit** can only be manufactured in 2 foot lengths, and is designed for building up trunk lines to the desired capacity of laying singly in the trench for terminal and lateral construction.

### 4-Way and 6-Way Multiple Conduit

Is the most satisfactory conduit made, strong in the web, straight in line, smooth in the duct, and flat on the ends. This ware is the most economical per duct foot to lay in the trench.

Style	Length of Piece, Feet	Duct Feet in Piece, Feet	Weight per Duct Foot	Duct Diameter Inches	Duct Feet Minimum Cor.	Price per Duct Foot
Square Duct, Single.....	1.5	1.5	10	3½	4278	\$0.09
Round Duct, Single.....	1.5	1.5	8	3½	5000	.09
2-Way Multiple.....	2	4	8	3¾	6250	.09
3-Way Multiple.....	2	6	8	3¾	6250	.09
4-Way Multiple.....	3	12	7.50	3¾	7800	.09
6-Way Multiple.....	3	18	7.50	3¾	7800	.09
9-Way Multiple.....	3	27	7.50	3¾	7800	.09

## WOODEN CONDUIT

This pine "pump-log duct" is largely used by telephone companies with underground lead-covered cable; it is creosoted, and, therefore, there is no limit to its life; the price is moderate, freight is low, breakage is very slight, cost of laying is low; dimensions, square, 4½ x 4½ inches outside; hole, 3 inches.

Prices on application.

## GLASS INSULATORS

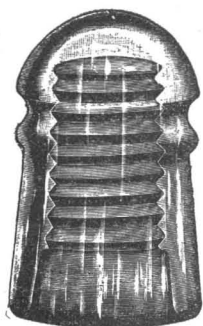

**No. 9 Pony  
Without Drip Points**

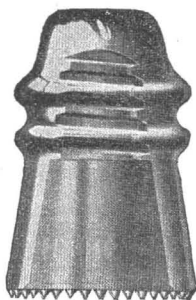

**No. 9 Pony  
With Drip Points**

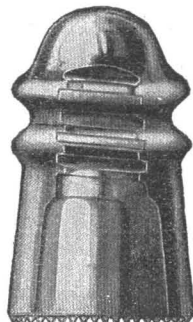

**No. 16 Long Distance**

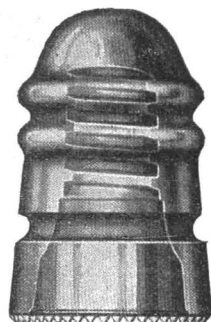

**No. 12 Double Groove**

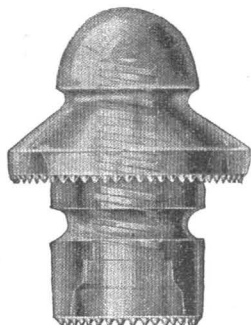

**No. 51 Perfect Transposition**

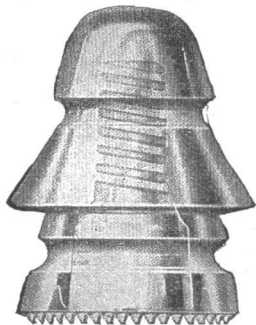

**No. 52 Transposition**

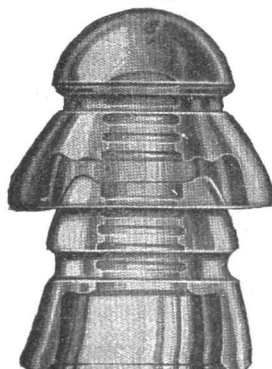

**No. 50 Two-piece Transposition**

### No. 9 Pony

#### With Drip Points

Dimensions:	Height $3\frac{3}{4}$ inches, diameter, $2\frac{1}{4}$ inches, groove, $\frac{3}{8}$ inch.
Weight Each	9 oz.
Approximate Weight per 1000, packed	675 lbs.
Std. Bbl. Quantity	400
List Price per 100	\$50.00

#### Without Drip Points

Dimensions:	Height, $3\frac{1}{2}$ inches; diameter, $2\frac{1}{8}$ inches; groove, $\frac{1}{4}$ inch.
Weight	10 oz.
Approximate Weight	750 lbs.
Std. Bbl.	350
List Price	\$50.00

### No. 12 Pony Double Groove

Dimensions:	Height, $3\frac{5}{8}$ inches; diameter, $2\frac{3}{8}$ inches; groove, top, $\frac{3}{8}$ inches; bottom, $\frac{1}{4}$ inch.
Weight	$10\frac{1}{2}$ oz.
Approximate Weight	750 lbs.
Std. Bbl.	400
List Price	\$160.00

### No. 31 Pony, Double Groove

Dimensions:	Height, $3\frac{1}{2}$ inches; diameter, 2 inches; groove, $\frac{1}{4}$ inch.
Weight	10 oz.
Approximate Weight	760 lbs.
Std. Bbl.	340
List Price	\$50.00

### No. 16 Long Distance, Regular

Dimensions:	Height, 4 inches; diameter, $2\frac{5}{8}$ inches; groove, $\frac{3}{8}$ inch.
Weight	14 oz.
Approximate Weight	1000 lbs.
Std. Bbl.	300
List Price	\$72.00

### No. 51 Perfect Transposition

Dimensions:	Height, $5\frac{1}{2}$ inches; diameter, $4\frac{1}{4}$ inches; bottom diameter, $2\frac{5}{8}$ inches; groove, top, $\frac{3}{8}$ inch; bottom, $\frac{1}{2}$ inch.
Weight	34 oz.
Approximate Weight	2500 lbs.
Std. Bbl.	100
List Price	\$98.80

### No. 52 Transposition

Dimensions:	Height, $4\frac{3}{4}$ inches; diameter, $3\frac{5}{8}$ inches; bottom diameter, $3\frac{1}{4}$ inches; groove, $\frac{3}{8}$ inch.
Weight	28 oz.
Approximate Weight	2100 lbs.
Std. Bbl.	125
List Price	\$148.00

### No. 50 Two-piece Transposition

#### SPECIAL SCREW THREAD

Dimensions:	Height, 5 inches; diameter, $3\frac{3}{4}$ inches; bottom diameter, $3\frac{1}{4}$ inches; groove, $\frac{3}{8}$ inch.
Weight	25 oz.
Approximate Weight	1950 lbs.
Std. Bbl.	125 prs.
List Price	\$200.00

Delivery F. O. B. Factory, Old Bridge, N. J. For warehouse deliveries write nearest house.

**GLASS INSULATORS (Continued)**

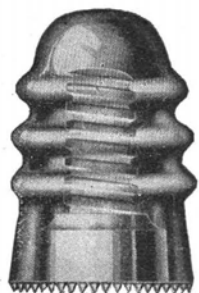

No. 54 Double Groove

**No. 54 Double Groove**

**STANDARD SCREW THREAD**

Dimensions: Height,  $4\frac{1}{4}$  inches, diameter,  $2\frac{7}{8}$  inches; groove,  $\frac{3}{8}$  inch.

Weight, Each	Approximate Weight per 1000, Packed	Std. Bbl. Quantity	List Price per 100
20 oz.	1375 lbs.	200	\$200.00

**No. 73 Pony, Brown or Duplex**

**STANDARD SCREW THREAD**

Dimensions: Height,  $2\frac{1}{2}$  inches; diameter,  $2\frac{1}{2}$  inches; groove,  $\frac{1}{4}$  inch.

Weight, Each	Approximate Weight per 1000, Packed	Std. Bbl. Quantity	List Price per 100
10 oz.	750 lbs.	350	\$92.00



No. 73 Brown



No. 72 Brown Brown Insulator Mounted on Bottom of Duplex Pin

**No. 72 Deep Groove, Brown or Duplex**

**STANDARD SCREW THREAD**

Dimensions: Height,  $2\frac{5}{8}$  inches; diameter,  $2\frac{3}{4}$  inches; groove,  $\frac{1}{2}$  inch.

Weight, Each	Approximate Weight per 1000, Packed	Std. Bbl. Quantity	List Price per 100
14 oz.	950 lbs.	250	\$92.00

Delivery F. O. B. Factory, Old Bridge, N. J. For warehouse deliveries write our nearest house.

**PORCELAIN INSULATORS**

**For Telephone and Telegraph Service**

**BROWN GLAZE FURNISHED UNLESS OTHERWISE SPECIFIED**

**Package Data and List Price**

List No.	Weight per 1000	Wt. packed per 1000	Quantity per Bbl.	List Price per 100
1011	750 lbs.	925 lbs.	400	\$4.96
1012	570 lbs.	700 lbs.	500	4.40

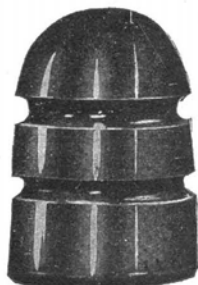

No. 1011

**PORCELAIN CLEATS**

**No. 333 Telephone Cleat**

(Bottom No. 333 $\frac{1}{2}$ )

Dimensions: Length,  $1\frac{3}{8}$  inches; width,  $\frac{1}{2}$  inch; groove,  $\frac{1}{4}$  inch; screw hole,  $\frac{3}{16}$  inch; height: top,  $\frac{1}{2}$  inch; bottom,  $\frac{1}{4}$  inch.

List No.	Description	No. per Bbl.	List Price per 1000
333	Top, glazed	21500	\$12.00
333 $\frac{1}{2}$	Bottom, glazed	22000	10.80

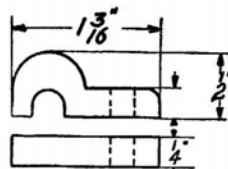

$\frac{2}{5}$  Size  
Top No. 333  
Bottom No. 333 $\frac{1}{2}$



No. 1012

Delivery F. O. B. Factory, Lisbon, O. For warehouse deliveries write nearest house.

## PORCELAIN TUBES

### Standard Unglazed Porcelain Tubes

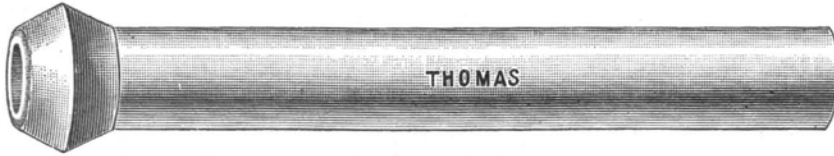

Tube list dimensions conform to the new rules of the Underwriters' Board.  
Barrel lots constitute a standard package.

#### List Price per 100

Length in Inches Under Head	$\frac{1}{16}$ Hole $\frac{1}{16}$ Out-side Diameter	$\frac{3}{16}$ Hole $\frac{1}{16}$ Out-side Diameter	$\frac{1}{2}$ Hole $\frac{1}{16}$ Out-side Diameter	$\frac{5}{8}$ Hole $\frac{1}{16}$ Out-side Diameter	$\frac{3}{4}$ Hole $\frac{1}{16}$ Out-side Diameter	1 Hole $\frac{1}{16}$ Out-side Diameter	$1\frac{1}{4}$ Hole $\frac{1}{16}$ Out-side Diameter	$1\frac{1}{2}$ Hole $\frac{1}{16}$ Out-side Diameter	$1\frac{3}{4}$ Hole $\frac{1}{16}$ Out-side Diameter	2 Hole $\frac{1}{16}$ Out-side Diameter	$2\frac{1}{4}$ Hole $\frac{1}{16}$ Out-side Diameter	$2\frac{1}{2}$ Hole $\frac{1}{16}$ Out-side Diameter
$\frac{1}{2}$	\$1.30	\$1.40										
1	1.30	1.40	\$2.10	\$2.70	\$3.00	\$4.50						
$1\frac{1}{2}$	1.30	1.50	2.10	2.70	3.30	5.30						
2	1.40	1.80	2.60	3.20	4.20	6.00						
$2\frac{1}{2}$	1.50	2.20	3.00	4.00	5.00	7.00	\$12.20	\$15.60	\$19.80	\$23.40	\$26.80	\$30.30
3	1.60	2.60	3.40	4.70	5.50	8.00	13.80	17.40	22.00	25.80	29.60	32.50
4	2.70	3.00	4.10	5.50	6.80	10.00	15.60	19.20	23.90	27.70	31.50	35.30
5	3.20	3.60	4.80	6.40	8.00	12.50	18.10	25.30	34.10	41.70	48.80	56.80
6	3.90	4.50	5.50	7.30	9.50	14.30	19.20	31.20	45.30	57.90	70.50	83.20
8	7.20	8.40	9.60	10.80	12.00	16.80	24.00	38.40	58.10	73.90	89.80	105.60
10	9.60	10.80	12.00	14.40	16.80	19.20	31.20	45.60	66.00	81.80	97.70	113.50
12	14.40	15.60	16.80	19.20	21.60	26.40	45.60	69.20	102.10	128.00	154.00	180.00
14	34.34	39.27	44.03	48.96	53.89	58.82	107.78	166.43	249.69	312.29	377.06	441.66
16	39.27	44.03	48.96	58.82	63.75	73.44	127.33	186.15	269.28	334.05	398.65	463.08
18	44.03	48.96	58.82	68.51	73.44	83.30	146.88	208.59	323.51	397.97	472.09	545.87
20	48.96	53.89	63.75	73.44	78.37	92.99	161.67	230.18	359.38	440.64	522.92	605.03
22	56.27	61.20	68.51	78.37	88.23	100.47	176.29	252.11	393.72	484.67	575.79	666.91
24	63.75	68.51	73.44	83.30	97.92	107.78	190.91	274.21	428.91	528.87	628.83	728.45

- For glazed tubes, add 50 per cent. to list prices.
- For split regular tubes, multiply list by ten (10).
- For floor tubes, multiply list by six (6).
- For split floor tubes, multiply list by ten (10).
- For headless tubes, multiply list by four (4).
- Curved and curved end tubes, multiply list by six (6).
- Crossover tubes split, multiply list by ten (10).
- Crossover tubes solid, multiply list by eight (8).

NOTE.—In computing prices on split floor tubes, headless tubes, curved and curved end tubes, the above list prices and lengths must be used as referring to "OVER-ALL" lengths, and not lengths under head.  
Split regular tubes lengths refer to under head.  
Crossover, solid and split tubes lengths refer to between heads.

#### SPECIAL PACKAGES

##### Standard Porcelain, Packed in Corrugated Paper Boxes

Special attention is called to the method of packing Standard Porcelain in heavy corrugated paper cartons. This method entirely eliminates the breakage incident to the usual barrel packages. Packing in cartons is done by hand, which insures inspection of every piece and the selection of only perfect material; this fact easily compensates for the slightly increased cost over the usual barrel packages.

##### Packed 100 in a Carton

Material	Over-all Dimension of Carton
$\frac{1}{16}$ x 3 inch Tubes	8 x 8 x 4 inches
$\frac{1}{16}$ x 4 inch Tubes	8 x 8 x 5 inches
$\frac{3}{8}$ x 3 inch Tubes	7 x 6 x 7 inches
$5\frac{1}{2}$ inch Split Knobs	9 x 8 x 5 inches
2-wire Cleats	9 x 8 x 5 inches
$\frac{3}{8}$ x 4 inch Tubes	9 x 8 x 6 inches

##### Packed 500 in a Carton

$\frac{1}{16}$ x 3 inch Tubes	8 x 10 x 12 inches
$\frac{1}{16}$ x 4 inch Tubes	10 x 10 x 12 inches
$\frac{3}{8}$ x 3 inch Tubes	8 x 10 x 16 $\frac{1}{2}$ inches
$\frac{3}{8}$ x 4 inch Tubes	10 x 10 x 16 $\frac{1}{2}$ inches
$5\frac{1}{2}$ inch Split Knobs	10 x 10 x 14 inches
2-wire Cleats	10 x 10 x 16 $\frac{1}{2}$ inches



Telephone Apparatus and Supplies

**PORCELAIN KNOBS**

**NO. 5 1/2 DESIGN**

Following knobs are all of the same general design, differing only in dimensions.

List No.	Height	Diameter	Groove	Hole
5 1/2	1 9/16 ins.	1 in.	3/8 in.	1/4 in.
5 1/2	1 3/4 ins.	1 1/8 ins.	3/8 in.	1/4 in.
5	1 1/4 ins.	1 in.	3/8 in.	1/4 in.

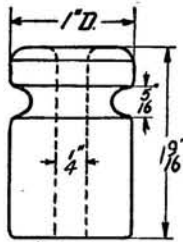

No. 5 1/2 Old Code

**Package Data and List Price**

List No.	Std. Pkg.	Pkg. Wt.	List per 1000
5 1/2	4500	400 lbs.	\$13.64
5 1/2	3500	410 lbs.	17.08
5	6000	430 lbs.	13.70

**MIDWAY DESIGN**

Following knobs are all of the same general design, differing only in dimensions.

List No.	Height	Diameter	Groove	Hole
Midway	1 7/8 ins.	1 3/4 ins.	3/8 in.	3/8 in.
4	1 1/2 ins.	1 1/2 ins.	3/8 in.	3/8 in.
4 1/2	1 1/8 ins.	1 1/2 ins.	7/16 in.	3/8 in.
10	1 3/4 ins.	1 5/8 ins.	3/8 in.	3/8 in.
10 1/2	1 7/8 ins.	1 1/2 ins.	3/8 in.	3/8 in.

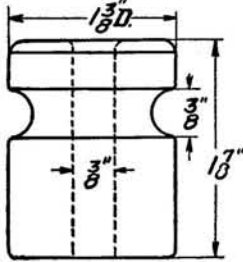

1/2 Size Midway No. 4

**Package Data and List Price**

List No.	Std. Pkg.	Pkg. Wt.	List per 1000
Midway	2000	390 lbs.	\$21.46
4	1900	415 lbs.	21.46
4 1/2	1700	410 lbs.	23.98
10	1500	400 lbs.	32.24
10 1/2	1500	415 lbs.	32.30

**NO. 22**

List No.	Height	Diameter	Groove	Hole
22	1 5/8 ins.	2 1/8 ins.	5/8 in.	1 in.

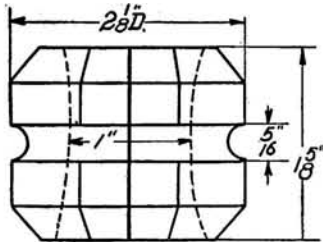

1/2 Size No. 22

**Package Data and List Price**

List No.	Std. Pkg.	Pkg. Wt.	List per 1000
22	1000	400 lbs.	\$38.72

**NO. 24 DESIGN**

Following knobs are all of the same general design, differing only in dimensions.

List No.	Height	Diameter	Groove	Hole
24	1 3/4 ins.	1 7/8 ins.	5/8 in.	7/8 in.
26	2 ins.	2 1/4 ins.	5/8 in.	7/8 in.

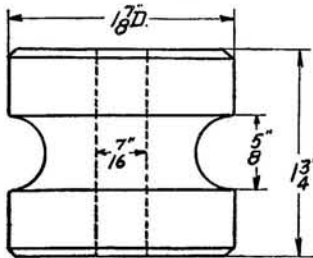

1/2 Size No. 24

**Package Data and List Price**

List No.	Std. Pkg.	Pkg. Wt.	List per 1000
24	1200	425 lbs.	\$55.82
26	700	420 lbs.	43.74

**FIBER CLEATS**



Style A



Style B



Style C



Style D



Style No. 1



Style No. 2



Style No. 2A

These cleats are neat, durable, easy to install, good insulators, and on account of the finished appearance they make, are just the thing for office or residence installation.

In ordering be sure to mention color preferred: red, gray or black; otherwise red will be furnished.

Style		Length	Width	Groove	List Price per 1000
A	Single groove cleat	3/4 in.	1 1/2 in.	1/4 x 1/8 in.	\$10.80
B	Double groove cleat	3/4 in.	1 3/4 in.	1/8 x 1/8 in.	10.80
C	Corner cleat	1 1/8 in.	1 3/8 in.	1/4 x 1/8 in.	9.60
D	Three-wire cleat	1 1/8 in.	1 3/8 in.	1/8 x 1/8 in.	21.60
1	Single groove				4.80
2	Double groove				4.80
2A	Double groove				4.80

**STAPLES AND TACKS**



No. 1

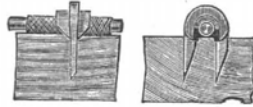

Insulated Saddle Staples



Compressed Cleats

**Blake Insulated Staples**

Designed for use on all low voltage circuits of interior wiring, such as telephone, telegraph, messenger call, annunciator and bell work.

List No.		List Prices			
		Single Pkg. per 100	Lots 1000 to 5000 per 1000	Lots 5000 to 10000 per 1000	Lots 10000 and Over per 1000
1	For hardwood, for single and twisted pair wire. . . .	\$0.30	\$2.90	\$2.80	\$2.60
3	For general use, for single and twisted pair wire. . . .	.30	2.90	2.80	2.60
5	For hardwood, for twisted 3 wire and extra heavy pair wire. . . . .	.34	3.20	3.10	2.90
6	For general use, for twisted 3 wire and extra heavy pair wire. . . . .	.34	3.20	3.10	2.90
7	For softwood, for twisted 3 wire and extra heavy pair wire. . . . .	.34	3.20	3.10	2.90

**Insulated Saddle Staples**

List No.	Inches in Diameter	List Price per 1000
5	5/100	\$1.20
10	10/100	1.40
15	15/100	1.60
25	25/100	3.40
50	50/100	10.80
40	40/100	10.00
100	1	13.60

**Blake Compressed Cleats**

These compressed cleats are treated so as to be impervious to dampness and moisture. They will not break under the blow of the hammer, so that wire nails can be used as well as screws. This enables a saving to be effected in both material and labor.

Blake Compressed Cleats. . . . .	List Prices			
	Single Pkg. of 100 Cleats per Pkg.	1000 and less than 5000 per 1000	5000 and less than 10000 per 1000	10000 and Over per 1000
	\$0.70	\$5.50	\$5.30	\$5.00

**Leather Nail Heads**

These leather nail heads or washers are used to prevent cracking the porcelain in knob or cleat wiring.

Wgt. per Box of 1000 1 lb.	List Price Per Thousand			
	Less than 10000	10000-25000	25000-50000	50000 and Over
	\$1.00	\$0.70	\$0.40	\$0.32



No. 15    No. 18    No. 20    No. 22

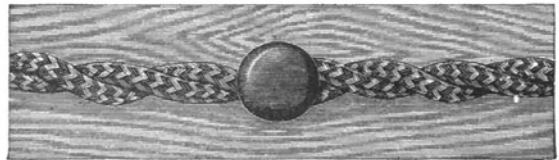

Milonite Nails

**Milonite Nails**

**"Milonite" Perfection Insulated Nails**

Diameter of head in four sizes. Length of nail to suit. Prevent short-circuiting. Color matches wire or wall. Wire can be taken down without cutting or injuring insulation.

List No.		List Price per 1000
15	Nails (plain top) . . . . .	\$2.04
18	Nails (plain top) . . . . .	2.04
20	Nails (plain top) . . . . .	2.38
22	Nails (plain top) . . . . .	2.72

**NOTE:** The above furnished in any color desired except white, for which add 34 cents to list.

## WIRE

The following table may be of assistance in deciding just what kind of wire should be ordered for any given service:

Service	Wire Recommended
<b>Aerial Lines:</b> 1. Rural lines. 2. Town lines (open wires). 3. Toll or other long lines where the best transmission is very important. 4. Lines running through trees where it is impracticable to trim.	Galvanized iron, copper clad, or hard drawn copper. Galvanized iron, copper clad, or hard drawn copper. Hard drawn copper. Weatherproof iron or copper to correspond with other wire used on the line.
<b>Subscribers' Wiring:</b> 1. Drops or loops (pole to protector). 2. Interior (protector to instrument). 3. Ground (protector to ground rod or other ground connection).	No. 17 twisted pair copper clad wire, No. 14 B.&S. twisted pair copper or No. 18 B.W.G. twisted pair ironite. Interior copper telephone wire (twisted pair or triple). Ground wire.
<b>Miscellaneous:</b> 1. Pot heads (for making lead cable pot heads). 2. Switchboard and telephone wiring. 3. Cross connecting on distributing frames.	Pot head wire. Switchboard wire. Flameproof cross connecting or distributing frame wire.

### Galvanized Iron Telephone Wire



Galvanized Wire

There are three grades of galvanized wire, classified as follows: Extra Best Best (E.B.B.), Best Best (B.B.) and Steel. Specify grade desired.

Extra Best Best (E.B.B.) wire is made from a special stock of great purity, producing wire of absolutely uniform quality, in which the elements of softness and elongation are combined with low electrical resistance to a marked degree. It is largely employed in long lines or service where low electrical resistance is both desirable and necessary.

Best Best (B.B.) wire is made from a stock of high quality, producing a wire somewhat less uniform and of higher resistance than E.B.B., but of greater tensile strength. This grade is used almost exclusively for the construction of subscribers' lines in exchanges, and on account of its great tensile strength is best adapted for rural or farmer lines.

Steel wire has a greater tensile strength than either E.B.B. or B.B., but on account of its greater electrical resistance is not very generally used.

The different grades of wire are Extra Galvanized, i.e., the wire is protected from atmospheric action by a heavy uniform coating of spelter.

B. W. G. Gauge	Diameter in Ins.	Approx. Breaking Strength in Lbs.			Weight in Lbs. per Mile	Length Coil
		E. B. B.	B. B.	Steel		
6	.203	1770	1947	2183	590	1/3
8	.165	1170	1287	1443	350	1/2
10	.134	774	851	955	258	1/2
12	.109	510	561	629	170	1/2
14	.083	297	327	366	99	1/2

Lowest market prices on application.

#### AVERAGE RESISTANCE OF IRON WIRE Ohms per Mile at 68° F.

B. W. G. Gauge	E. B. B.	B. B.	Steel
6	8.21	9.6	11.35
8	12.42	14.53	17.18
10	18.83	22.04	26.04
12	28.46	33.3	39.36
14	49.08	57.44	67.88

## WIRE

## Hard-drawn Copper Wire

Copper wire for telephone lines is highly desirable where climatic conditions are unfavorable, such as salt air or where a great deal of dampness is present, which would, of course, corrode or rust out iron wire in a few years, no matter how well galvanized. Copper wire is unaffected by moisture, smoke, or other gases, and will last practically indefinitely. Further, it has a definite junk value of approximately 80 per cent. of the original cost should it ever be taken down for any cause, which is not true of iron wire.

Size or Gauge	Approx. B.&S. Gauge Equivalent	Diameter Inches	Weight per Mile	Put up in Coils	Resistance Ohms per Mile
8 B.W.G.	No. 6	.165	438	½ mile	1.97
12 N.B.S.	No. 10	.104	172	1¼ mile	4.97
14 N.B.S.	No. 12	.080	103	¾ mile	8.40

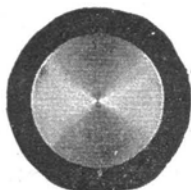

Enlarged Cross Section of Copper Clad Wire

## Copper Clad Wire (C. C. C.)

This wire consists of a steel core having a permanently welded copper film or coating. It is made in all standard sizes, either bare or insulated, the insulated wire being furnished in singles, twisted pairs and triples.

The No. 17 B.&S. gauge insulated twisted pair is the standard for drop wire work of nearly all the large operating telephone companies.

The bare wire is not intended to displace pure copper wire for long and important toll lines. It will be found entirely satisfactory for medium length local lines where a longer life, greater conductivity, and tensile strength are desired than secured by the use of galvanized iron wire.

In addition to a considerable saving in first cost over copper, copper clad wire will effect a saving of from 50 to 75 per cent. in maintenance charges, due to its much greater tensile strength.

It is particularly adapted to Municipal Fire and Police Telegraph, and Railroad Signal service, or wherever medium conductivity and great tensile strength are the principal requirements. Prices on application.

## Average Conductivity 40 Per Cent. of Copper

## Comparative Characteristics—Bare Wire

Size B.&S. Gauge	Approx. Weight per Mile		Approx. Breaking Weight		Av. Resistance Int. Ohms per Mile at 60° F.	
	Copper Clad	Copper	Copper Clad	Copper	Copper Clad	Copper
10	154	165.8	751	506	12.91	5.278
11	122	131.3	613	403	16.25	6.665
12	97	104.2	499	318	20.49	8.398
14	61	65.5	333	202	32.80	13.35

## WIRE

### Weatherproof Wire

(Tree Wire)



This is sometimes called tree wire. Its use is advised where branches of trees interfere with line and it is impracticable to trim for some reason.

These wires are extensively used in telephone and telegraph work, and have the same insulation as regular weatherproof line wires. They are finished with the same smooth polish as all other wires, and are put up for shipment in coils only, thoroughly wrapped in burlap.

Nos. 8, 9 and 10 doubled braided are made up on special order only.

#### IRON WIRE

Size Iron Wire Gauge (B.W.G.)	Double Braided Approximate Pounds per Mile	Triple Braided Approximate Pounds per Mile	Length of Coils
10	350	400	1/2 mile
12	230	260	1/2 mile
14	150	175	1/2 mile

#### COPPER WIRE

Size B.&S. Gauge	Triple Braided Approximate Weight Lbs. per Mile	Length Coils
10	280	1/2 mile
12	185	1/2 mile
14	130	1/2 mile

#### COPPER CLAD WIRE

Size B.&S. Gauge	Double Braid Weight in Lbs.		Triple Braid Weight in Lbs.		Approximate Weight of Coils Lbs.
	1000 Feet	Mile	1000 Feet	Mile	
10	44	229	50.75	268	150-200
12	28.7	151	33.75	178	80-120
14	19	102	24.00	127	50-75

The use of triple braided wires is recommended.

### No. 17 B.&S. Twisted Pair Copper Clad



#### DISTRIBUTING OR DROP WIRE

This is the standard wire for making the drop from the pole to the house, and is used by nearly all the large operating telephone companies. It replaces No. 14 B.&S. Twisted Pair Copper Distributing Wire on account of its light weight, great tensile strength, and lower cost.

Insulated to a diameter of  $\frac{7}{8}$  inch over rubber, and covered with a cotton braid saturated with black weatherproof compound. Weight per 1000 feet (twisted pair), 36 lbs. Furnished in coils of approximately 1000 feet each.

Prices on application.

## WIRE

### Twisted Pair Iron

#### DISTRIBUTING OR DROP WIRE

This is a special conductor, much lighter than copper, and just as flexible.

The conductor is tinned by a special process to prevent rust. It is then rubber-covered, the braid is saturated and waxed and then twisted in pairs.

A raised thread on one of the conductors is used as a tracer.

Twisted pair drop wire is made in the following sizes:

No. 19 B.W.G. or No. 18 B.&S.  $\frac{7}{8}$  inch insulation.

No. 18 B.W.G. or No. 16 B.&S.  $\frac{4}{3}$  inch insulation.

No. 16 B.W.G. or No. 14 B.&S.,  $\frac{5}{2}$  inch insulation.

No. 14 B.W.G. or No. 12 B.&S.,  $\frac{1}{4}$  inch insulation.

Also furnished in single and triple conductors.

Prices on application.

### Twisted Pair Copper Bridle Wire



The standard wire for this use is No. 18 B.&S. twisted pair, insulated to a diameter of  $\frac{7}{8}$  inch over rubber and covered with a cotton braid saturated with a black weatherproof compound, one conductor having a raised tracer.

This wire is used largely for block wiring or in ring construction work where a number of pairs of wires are suspended from a messenger by means of galvanized cable suspension or Locke rings.

Prices on application.

### Ground Wire—Single Conductor Copper



This wire is used to run from the protector to the ground connection at subscribers' stations, and is also used for cross connecting and inside wiring in connection with ground return systems where only one wire is used.

It consists of a No. 18 B.&S. copper wire, insulated to a diameter of  $\frac{7}{8}$  inch over rubber and covered with a cotton braid saturated with black weatherproof compound.

Prices on application.

### Pot Head Wires



The standard wire for pot head work is either 19, 20 or 22 B.&S. gauge in single or twisted conductor. The insulation of this wire is of high quality, suitable to withstand the effects of the hot sealing compound and outside exposure without a protecting braid. As a distinguishing marker one conductor of the twisted pair has a double ridge on the insulation. Make sure in ordering this wire that it has the double ridge; as this insures you a "quality product."

Weight per 1000 feet (twisted pair), 19 lbs. Coil lengths, 200-1500 feet.

Gauge	Weight per 1000 Feet, Twisted Pair	Coil Length
19, 20 or 22 B.&S. Pot head wire . . . . .	19 lbs.	200-1500 ft.

Prices on application.

## WIRE

## Interior Copper Telephone Wire



## Twisted Pair and Triple Conductors

The wire most commonly used for this purpose is No. 19 B.&S. gauge, insulated to a thickness over the rubber of  $\frac{3}{32}$  inch or  $\frac{1}{4}$  inch. The conductors are braided with a dry glazed braid and then twisted together.

Olive green braid with a tracer thread in one conductor, is standard, but various color combinations can be furnished. Prices on application.

Size B.&S. Gauge	Approximate Weight per 1000 Feet Lbs.	Diameter over Rubber Inches	Put up in Coils of Feet
19	22	$\frac{3}{32}$	200-1500

## Switchboard Wire



Copper wire with double silk and single cotton paraffined insulation of assorted colors. Wound on spools; furnished by the pound.

Size, B.&S. Gauge
No. 19
No. 22
No. 19
No. 22

Single Conductor
Single Conductor
Twisted Pair
Twisted Pair

Prices on application.

## Cross Connecting or Distributing Frame Wire

This wire is used for cross connecting work on distributing frames, and is made in singles, twisted pairs, and triples. It is made in No. 20 and No. 22 B.&S. gauge, insulated to  $\frac{5}{16}$  inch with a flameproof braid.

The twisted pair is furnished having one red and one white conductor.

Prices on application.

## Annunciator Wire



Insulated with two winds of cotton yarn applied in opposite directions, saturated with a special wax compound and highly polished. This makes a very compact insulation. Furnished either on spools containing about 8 lbs. or exactly 1 lb. and in 1 lb. coils, and packed in cases containing approximately 200 lbs. Furnished in colors and styles as follows—either plain copper or tinned; copper furnished unless otherwise ordered; red, blue, red and white, brown, white, olive, yellow, blue and white.

Single Conductor		Twisted Pairs	
Size B.&S. Gauge	Lbs. per 1000 Feet	Size B.&S. Gauge	Lbs. per 1000 Feet
14	15	14	30
16	9.5	16	19
18	6.5	18	13
20	4.5	20	9

## SLEEVE CONNECTORS



Fig. 1  
Double Tube Sleeve



Fig. 2  
Sleeve and Wire Welded Together in One Solid Piece

### Copper Sleeves

#### For Splicing Copper Wire

The above connectors are of the double tube type, and are made accurately and very close to the size of the wire for which they are intended.

When twisted the sleeve is drawn snugly around the wire, forming an absolutely solid joint which air and moisture cannot penetrate. Fig. 2 shows sleeve sawed lengthwise after being twisted.

#### DOUBLE TUBE

Sizes of Wire	Wire	—Length, Ins.—		Wire	Diam.	—Length, Ins.—	
		Full Sleeve	Half Sleeve			Full Sleeve	Half Sleeve
8 B.W.G.	.165	6 $\frac{3}{4}$	3 $\frac{3}{8}$	14 N.B.S.	.080	4 $\frac{1}{2}$	2 $\frac{1}{4}$
10 N.B.S.	.128	5 $\frac{1}{2}$	...	14 B.&S.	.064	4	2
10 B.&S.	.102	4 $\frac{3}{4}$	2 $\frac{3}{8}$	17 B.&S.	.045	4	2
12 N.B.S.	.104	4 $\frac{3}{4}$	2 $\frac{3}{8}$	18 B.&S.	.040	4	2
12 B.&S.	.080	4 $\frac{1}{2}$	2 $\frac{3}{4}$	19 B.&S.	.036	...	1 $\frac{1}{2}$

#### COMBINATION

12 N.B.S.—14 N.B.S.	.104—.080	4 $\frac{3}{4}$	2 $\frac{3}{8}$	14 N.B.S.—14 B.&S.	.080—.064	4	2
12 N.B.S.—14 B.&S.	.104—.064	4 $\frac{3}{4}$	2 $\frac{3}{8}$	14 N.B.S.—17 B.&S.	.080—.045	4	2
12 N.B.S.—16 B.&S.	.104—.051	4 $\frac{3}{4}$	2 $\frac{3}{8}$	14 B.&S.—17 B.&S.	.064—.045	4	2
12 N.B.S.—17 B.&S.	.104—.045	4 $\frac{3}{4}$	2 $\frac{3}{8}$	18 B.&S.—19 B.&S.	.040—.036	...	1 $\frac{1}{2}$

### Tinned Steel Sleeves

#### For Splicing Iron Wire

#### DOUBLE TUBE

9 B.W.G.	.148	5 $\frac{3}{4}$	...	12 B.W.G.	.109	4 $\frac{3}{4}$	2 $\frac{3}{8}$
10 B.W.G.	.134	5 $\frac{1}{2}$	...	14 B.W.G.	.083	4 $\frac{1}{2}$	2 $\frac{1}{4}$

#### COMBINATION

12 B.W.G.—14 B.W.G.	.109—.083	4 $\frac{3}{4}$	...
---------------------	-----------	-----------------	-----

Prices on application.

TEST CONNECTORS

Western Electric Bridging Connectors

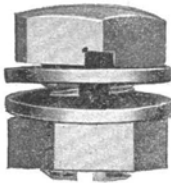

No. 3



No. 2

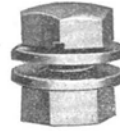

No. 1

These consist of a brass bolt slotted to receive two or more wires, which are clamped by two washers and a hexagonal nut. Will connect two or more wires of different sizes used in telephone construction, holding them securely regardless of vibration. These connectors can be slipped under and secured to a through line for making branch connections, permitting the joining of a wire any size smaller than that of the main line.

List No.	Description	List Price per 100
1	Brass bolt slotted to receive No. 17 or No. 18 B.&S. wire.....	\$4.00
2	Brass bolt slotted to receive No. 12 B.&S. or No. 14 N.B.S. wire.....	4.20
3	Brass bolt slotted to receive No. 10 B.&S. or No. 12 N.B.S. wire.....	9.00

Fahnestock Connectors

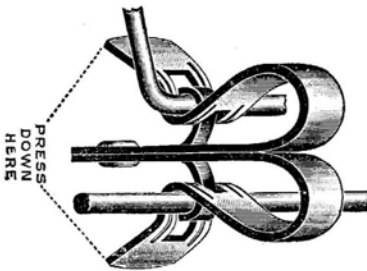

No. 30  
Line Connector

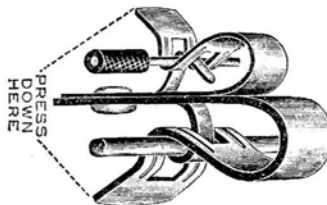

No. 31  
Line Connector

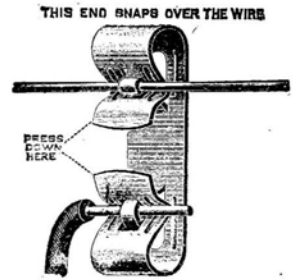

No. 34  
Line Connector

List No.	Description	List Price Each
30A	For connecting wires on test poles. Recommended for use on No. 12 N.B.S. (.104 in.) and No. 14 N.B.S. (.080 in.) wire.....	\$0.16
31	For attaching subscribers' drops or branch circuits to main line. Large clip snaps over line wire. Small clip does not snap over line, but will take up to and including a No. 14 B.&S wire.....	.15
34	One end snaps over a No. 12 B.W.G. wire. The other end does not snap over the wire, but will take any size wire up to No. 12 B.W.G.....	.16
35	Does not snap over the wire on either end. Will take up to and including No. 9 B.W.G. wire.....	.16

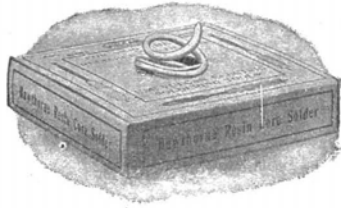

## SOLDER Bar and Wire Solder

List No.		List Price
460060	Strictly Half and Half Bar Solder....	per Lb.
460061	Strictly Half and Half Wire Solder....	Prices on application

## W. E. Resin Core Solder

460062	Resin Core Solder in 1/2 lb. boxes....	Prices on application
460063	Resin Core Solder, on 1 lb. spoons....	
460064	Resin Core Solder, on 2 lb. spoons....	
460065	Resin Core Solder, on 5 lb. spoons....	
460066	Resin Core Solder, on 10 lb. spoons....	

## Cable Solder

460067	W. E. Cable Solder.....	Prices on application
--------	-------------------------	-----------------------

## Solderall

A complete solder, and non-corrosive fluid. Combined in paste form and put up in convenient collapsible tubes.

List No.		List Price
460058	Solderall.....	per Doz. \$10.00

## SOLDERING ACCESSORIES Western Electric Soldering Paste

This is a superior quality of soldering paste. It will not corrode or injure in any way the material that is to be soldered. It takes the place of injurious acids and is equally effective. It may be applied with a rag, a stick or even with the fingers. It is particularly intended for those who prefer a soldering flux in paste form rather than the soldering stick, and in cases where it is inconvenient to heat the joint in order to apply the stick flux.

		List Price Each			
		Less than 12	12 to 36	36 to 108	108 and Over
List No.					
460016	2 oz. tin cans.....	\$0.18	\$0.16	\$0.12	\$0.10
460017	4 oz. tin cans.....	.25	.20	.16	.14
		Net Prices per Lb.			
		Less than 5 Lbs.	5 to 100 Lbs.	100 Lbs. and Over	
460018	1/2 lb. tin cans.....	\$0.80	\$0.54	\$0.50	
460019	1 lb. tin cans.....	.72	.52	.46	
460020	5 lb. tin cans.....	.68	.50	.40	



## Soldering Salts

Our soldering salt combines in soluble crystal form the most efficient soldering agents known to chemistry. It dissolves readily in water and does not give off any obnoxious odors or gases. Directions for dissolving in water to make a soldering agent of proper strength are included with each package.

### Western Electric

### Allen's

List No.	Description	List Price Each	List No.	Description	List Price Each
460040	1/2 lb. cans	\$0.72	460046	1/2 lb. bottles	\$0.45
460041	1 lb. cans	.68	460047	1 lb. bottles	.60
461045	5 lb. cans	.42	460048	5 lb. bottles	3.00

## Western Electric Soldering Stick

This soldering stick is made under the same formula as our paste and put up in a neat, substantial package. Its use is very convenient as it can be carelessly carried in the workman's tool kit or pocket. To apply this stick it is only necessary to heat the joint to be soldered and rub it with the bared end of the stick.



List No.	Description	List Price Each
460052	Western Electric Soldering Stick.....	\$0.25

## INSULATING TAPES

### Victor Tapes



Victor Tape

These are commercial grades of tape which we furnish regularly in half pound rolls,  $\frac{3}{4}$  inch wide. We furnish under this same brand both a friction tape and a rubber splicing compound. Therefore it is always necessary to specify whether friction tape or splicing compound is desired. The standard width of all tapes is  $\frac{3}{4}$  inch, but on special orders we can furnish the Victor friction tape either  $\frac{1}{2}$  inch, 1 inch,  $1\frac{1}{4}$  inches,  $1\frac{1}{2}$  inches or 2 inches wide.

#### Victor Friction Tape

Description	List Price per Lb.
$\frac{3}{4}$ in. black tape . . . . .	\$0.80

#### Victor Splicing Compound

Description	List Price per Lb.
$\frac{3}{4}$ in. rubber tape . . . . .	\$1.50



Amazon Tape

### Amazon Tapes

These tapes are of excellent quality and meet the requirements of those desiring something better than a regular commercial product. The price is accordingly somewhat higher than our Victor tapes

#### Amazon Friction Tape

Description	List Price per Lb.
$\frac{3}{4}$ in. black tape . . . . .	\$0.90

#### Amazon Splicing Compound

Description	List Price per Lb.
$\frac{3}{4}$ in. rubber tape . . . . .	\$1.60

### Okonite Tapes

$\frac{3}{4}$  Inch,  $\frac{1}{2}$  Lb. Rolls

Description	List Price per Lb.
Manson Black Friction . . . . .	\$1.16
Manson White Friction . . . . .	1.16
Okonite Splicing Compound . . . . .	1.86

### P. & B. Tape

$\frac{3}{4}$  Inch,  $\frac{1}{2}$  Lb. Rolls

Black Weatherproof . . . . .	\$0.80
------------------------------	--------

NOTE: If desired in  $\frac{1}{4}$  lb. rolls add  $\frac{1}{2}$  cent. per lb. to list.

### Star Cotton Tape or Webbing

A plain cotton tape of good quality without compound. It is furnished regularly in rolls containing 36 lineal yards or will be furnished in other lengths when desired. Used for binding cable splices.

List No.	Width, Ins.	Thickness Ins.	List Price Gr. Yds.	List No.	Width, Ins.	Thickness Ins.	List Price Gr. Yds.
5918	$\frac{1}{2}$	.013	\$1.36	5906	1	.013	\$2.30
5821	$\frac{5}{8}$	.013	1.60	9652	$1\frac{1}{2}$	.013	3.60
5727	$\frac{3}{4}$	.013	1.80				

## PAPER SLEEVES

For Splicing Cable Conductor

Style	Dimensions	List Price per 1000	Style	Dimensions	List Price per 1000
2 $\frac{1}{2}$ A	$\frac{1}{8}$ x $2\frac{3}{4}$ ins.	\$1.50	18A	$\frac{1}{8}$ x 18 ins.	\$7.50
3 B	$\frac{3}{16}$ x 3 ins.	1.50	18B	$\frac{3}{16}$ x 18 ins.	7.50
3 C	$\frac{7}{32}$ x 3 ins.	1.50	18C	$\frac{7}{32}$ x 18 ins.	7.50

## SOFT RUBBER TUBING

Inside Diam.	Covers B.&S. Wire	Feet per Lb.	List Price per Lb.	Inside Diam.	Covers B.&S. Wire	Feet per Lb.	List Price per Lb.
$\frac{1}{8}$ in.	36	125	\$2.20	$\frac{1}{4}$ in.	10	20	\$1.60
$\frac{3}{8}$ in.	20	60	2.20	$\frac{5}{16}$ in.	6	15	1.60
$\frac{3}{16}$ in.	14	30	1.60	$\frac{3}{8}$ in.	4	12	1.60

Telephone Apparatus and Supplies

## PARAFFINE

White, commercially refined paraffine, principally used in "boiling out" paper insulated cables. Usually furnished in cakes of 11 lbs. each.  
Price on request.

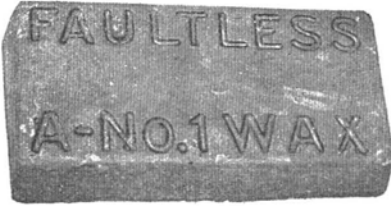

## BEESWAX COMPOUND

For impregnating or "boiling out" cable forms, cores of wool or silk and cotton cables, etc., to render them moisture resisting and prevent the insulation from fraying.

Furnished in cakes of 1 lb. each.

Price on request.



## *Western Electric* COMPOUND

For insulating and sealing pot heads, and for all other purposes where it is desired to insulate and protect wires or other current-carrying parts of apparatus from moisture.

When heated it can be poured, and as it cools hardens into the form of the mold.

Furnished in 1 and 10 lb. packages.

Price on request.

## CABLE PASTERS

Gummed strip of white paper  $2\frac{1}{8}$  inches wide by 25 inches long. Used by cablemen in wiping lead cable joints to limit the length of the wiped joint.

Furnished in packages of 250.

## COTTON SLEEVING

Tubular white cotton fabric tubing used in making tap or straight splices in cables which are likely to be re-opened. Furnished in 1 lb. spools.

Size  
 $\frac{5}{8}$  in.  
 $\frac{1}{4}$  in.

Diameter  
.156 in.  
.250 in.

**SPOONS AND SHOVELS**



Round Point Regular Spoon Spade D Handle Square Point Flat Toe Spoon Square Point

**Long Handle Spoons**

HUSSEY-BINNS BRAND					VICTOR BRAND				
Length of Handle	With 9-in. Strap		With 18-in. Strap		Length of Handle	With 9-in. Strap		With 18-in. Strap	
	List No.	*List Price per Doz.	List No.	*List Price per Doz.		List No.	*List Price per Doz.	List No.	*List Price per Doz.
6 ft.	760000	\$25.62	760006	\$28.12	6 ft.	760012	\$21.88	760017	\$24.38
7 "	760001	27.24	760007	29.74	7 "	760013	23.12	760018	25.62
8 "	760002	29.74	760008	32.24	8 "	760014	25.62	760019	28.12
9 "	760003	32.24	760009	34.76	9 "	760015	28.12	760020	30.62
10 "	760004	34.74	760010	37.24	10 "	760016	30.62	760021	33.12

NOTE: Specify whether regular or flat toe spoon is desired when ordering.

**Long Handle Shovels**

HUSSEY-BINNS BRAND					VICTOR BRAND				
Length of Handle	With 9-in. Strap		With 18-in. Strap		Length of Handle	With 9-in. Strap		With 18-in. Strap	
	List No.	*List Price per Doz.	List No.	*List Price per Doz.		List No.	*List Price per Doz.	List No.	*List Price per Doz.
6 ft.	760022	\$23.76	760028	\$26.26	6 ft.	760034	\$20.62	760039	\$23.12
7 "	760023	25.38	760029	27.88	7 "	760035	21.88	760040	24.38
8 "	760024	27.88	760030	30.38	8 "	760036	24.38	760041	26.88
9 "	760025	30.38	760031	32.88	9 "	760037	26.88	760042	29.38
10 "	760026	32.88	760032	35.38	10 "	760038	29.38	760043	31.88

With spoon handles, 6 and 7 foot \$1.25 list per dozen additional; 8, 9 and 10 foot, \$2.50.

With spoon handles, 6 and 7 foot \$1.25 list per dozen additional; 8, 9 and 10 foot, \$2.50.

**Spoon and Shovel Handles, Victor Brand**

Spoon Handles				Shovel Handles				
Length	List No.	*Per Doz.	Length	List No.	*Per Doz.	Length	List No.	*Per Doz.
6 ft.	760044	\$10.62	9 ft.	760047	\$16.24	6 ft.	760050	\$9.38
7 "	760045	11.24	10 "	760048	18.74	7 "	760051	10.00
8 "	760046	13.74				8 "	760052	11.24

**Shovels and Spades**

	Hussey-Binns		Victor	
	List No.	*Per Doz.	List No.	*Per Doz.
D Handle, Square Point Shovel	760056	\$20.74	761228	\$15.02
D Handle, Round Point Shovel	760057	20.74	761229	15.02
D Handle, Square Point Spade	760058	20.74	761230	15.02

Specify whether Malleable Iron, D, or Tamping Handles desired, no extra charge.

Above furnished with 5-foot overall Handle when specified at same price as D Handle.

\* Delivery, F. O. B. Pittsburgh, New York, Chicago and St. Louis. For warehouse deliveries write nearest house.

## DIGGING AND TAMPING BARS



Crow and Digging Bar

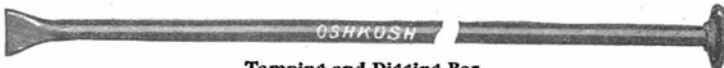

Tamping and Digging Bar



Plain Digging Bar

### Crow and Digging Bar

List No.		List Price		List No.		List Price	
		Wgt.	Each			Wgt.	Each
1060	1 in. octagon, 6 ft. long...	17 lbs.	\$3.90	1063	1 1/8 in. octagon, 6 ft. long..	22 lbs.	\$5.30
1061	1 in. octagon, 7 ft. long...	20 lbs.	4.40	1064	1 1/8 in. octagon, 7 ft. long..	26 lbs.	5.70
1062	1 in. octagon, 8 ft. long...	23 lbs.	4.90	1065	1 1/8 in. octagon, 8 ft. long..	30 lbs.	6.20

### Tamping and Digging Bar

1070	1 in. octagon, 6 ft. long...	17 lbs.	\$4.90	1073	1 1/8 in. octagon, 6 ft. long..	22 lbs.	\$5.40
1071	1 in. octagon, 7 ft. long...	20 lbs.	5.30	1074	1 1/8 in. octagon, 7 ft. long..	26 lbs.	5.80
1072	1 in. octagon, 8 ft. long...	23 lbs.	5.60	1075	1 1/8 in. octagon, 8 ft. long..	30 lbs.	6.60

### Plain Digging Bar

1080	1 in. round, 6 ft. long....	16 1/2 lbs.	\$1.90	1083	1 1/8 in. round, 6 ft. long....	21 lbs.	\$2.90
850	1 in. round, 7 ft. long....	19 lbs.	2.40	1084	1 1/8 in. round, 7 ft. long....	24 1/2 lbs.	3.30
1082	1 in. round, 8 ft. long....	21 1/2 lbs.	3.10	851	1 1/8 in. round, 8 ft. long....	28 lbs.	3.70



Digging Spud with Tamper



Electric Tamping Bar



Loy or Slick

### Digging Spud With Tamper

List No.		Weight per Doz.	List Price Each
852	Digging spud with tamper, 9 ft. long.....	234	\$5.30

### Electric Tamping Bar

1044	Electric tamping bar, 8 ft. long.....	...	\$3.60
------	---------------------------------------	-----	--------

### Loy or Slick

853	Loy or slick, 8 ft. handle.....	210	\$4.40
-----	---------------------------------	-----	--------



Tamping Bar with Heavy Iron Shoe



Tamping Bar with Extra Heavy Iron Shoe

### Tamping Bar

WITH HEAVY IRON SHOE

WITH EXTRA HEAVY IRON SHOE

List No.		List Price		List No.		List Price	
		Wgt. per Doz.	Each			Wgt. per Doz.	Each
854	Tamping bar, 7 ft. handle.	150 lbs.	\$2.30	1054	Tamping bar, 7 ft. handle.	160 lbs.	\$2.50
855	Tamping bar, 8 ft. handle.	170 lbs.	2.40	1055	Tamping bar, 8 ft. handle.	180 lbs.	2.90

Delivery F. O. B. Oshkosh, Wis. For warehouse deliveries write nearest house.

DIGGING TOOLS

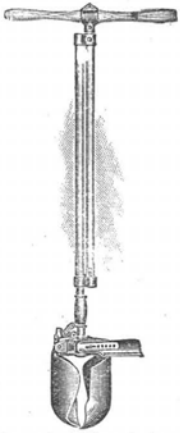

Standard Earth Auger



Iwan Post Hole Auger

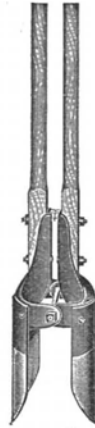

Hercules Post Hole Digger



Split Handle Post Hole Digger



Gibbs Post Hole Digger

Standard Earth Auger

List No.		*List Price Each
14	Will bore 8, 9, 10, 11, 12, 13, or 14 in. holes.....	\$12.00
16	Will bore 8, 9, 10, 11, 12, 13, 14, 15, or 16 in. holes.....	12.00

Iwan Post Hole Augers

List No.		†List Price per Doz.	List No.		†List Price per Doz.
761254	4 in.; length 4 ft.....	\$30.80	761259	9 in.; length 4 ft.....	\$35.20
761255	5 in.; length 4 ft.....	30.80	761260	10 in.; length 4 ft.....	39.60
761256	6 in.; length 4 ft.....	30.80	761261	12 in.; length 6 ft.....	105.60
761257	7 in.; length 4 ft.....	33.00	761262	14 in.; length 6 ft.....	132.00
761258	8 in.; length 4 ft.....	33.00	761263	16 in.; length 6 ft.....	158.40

Hercules Post Hole Digger

List No.		†List Price per Doz.
761264	6 in. diameter; 4 ft. handle.....	\$16.24

Split Handle Post Hole Digger

761265	6 in. diameter; 4 ft. handle.....	\$14.00
761266	6 in. diameter; 7 ft. handle.....	20.00

Gibbs Post Hole Digger

761267	7 in. diameter; 4½ ft. handle.....	\$22.00
--------	------------------------------------	---------

Picks and Mattocks



Mattock



Adze Eye



Panama

No. List		Weight Lbs.	†List Price per Doz.	No. List		Weight Lbs.	†List Price per Doz.
296	Adze Eye.....	5 to 6	\$7.00	450	Panama R. R. Pick.....	7	\$22.24
296	Adze Eye.....	6 to 7	7.50	450	Panama R. R. Pick.....	8	22.24
396	Adze Eye.....	7 to 8	8.00	Above are furnished with handles.			
308	Adze Eye.....	6 to 7	9.00	424	Mattock, Long Cutter.....	5	10.80
308	Adze Eye.....	7 to 8	9.50	424	Mattock, Long Cutter.....	6	11.46

\*Delivery F. O. B. Factory Chicago, Ill. †Delivery F. O. B. Factory, South Bend, Ind. ‡Delivery F. O. B. Factory, Pittsburgh, Pa. For warehouse deliveries write nearest house.

**PIKE POLES**



Pike Poles Nos. 805-816



Western Electric Pattern Nos. 818-824

**Pike Poles**

**Standard Small Size**

List No.	Handles	Weight List Price		List No.	Handles	Weight List Price	
		per Doz.	Each			per Doz.	Each
805	1 3/4 ins., 10 ft.	70 lbs.	\$1.40	807	1 3/4 ins., 14 ft.	110 lbs.	\$1.80
806	1 3/4 ins., 12 ft.	90 lbs.	1.60	808	1 3/4 ins., 16 ft.	130 lbs.	2.10

**Standard Heavy Size**

809	2 1/4 ins., 10 ft.	80 lbs.	\$1.80	813	2 1/4 ins., 18 ft.	170 lbs.	\$3.00
810	2 1/4 ins., 12 ft.	100 lbs.	2.00	814	2 1/4 ins., 20 ft.	200 lbs.	3.40
811	2 1/4 ins., 14 ft.	120 lbs.	2.30	815	2 1/4 ins., 22 ft.	230 lbs.	4.10
812	2 1/4 ins., 16 ft.	140 lbs.	2.60	816	2 1/4 ins., 24 ft.	260 lbs.	4.60

**Western Electric Pattern**

818	2 1/2 ins., 12 ft.	150 lbs.	\$2.40	822	2 1/2 ins., 20 ft.	240 lbs.	\$3.80
819	2 1/2 ins., 14 ft.	165 lbs.	2.80	823	2 1/2 ins., 22 ft.	260 lbs.	4.50
820	2 1/2 ins., 16 ft.	185 lbs.	3.10	824	2 1/2 ins., 24 ft.	285 lbs.	5.00
821	2 1/2 ins., 18 ft.	215 lbs.	3.50				

Delivery F. O. B. Factory, Oshkosh, Wis. For warehouse deliveries write nearest house.

**CARRYING HOOKS, CANT HOOKS AND PEAVIES**



Regular Pattern



Western Union Pattern

**Carrying or Lug Hooks**

**REGULAR PATTERN**

List No.	Handles	Weight List Price	
		per Doz.	Each
295	2 1/2 ins. x 4 ft. maple handle	85 lbs.	\$3.00
296	2 1/2 ins. x 4 1/2 ft. maple handle	90 lbs.	3.20
297	2 1/2 ins. x 5 ft. maple handle	95 lbs.	3.30

**EXTRA HEAVY WITH STEEL SWIVELS**

List No.	Handles	Weight List Price	
		per Doz.	Each
298	3 ins. x 5 ft. maple handle	145 lbs.	\$4.40
299	3 ins. x 6 ft. maple handle	155 lbs.	5.00
300	3 ins. x 7 ft. maple handle	165 lbs.	5.40

**Western Union Pattern**

800	4 ft. maple handle	135 lbs.	\$3.80	803	7 ft. maple handle	175 lbs.	\$5.50
801	5 ft. maple handle	150 lbs.	4.30	804	8 ft. maple handle	190 lbs.	5.60
802	6 ft. maple handle	165 lbs.	4.70				



Socket Peavy



Cant Hook

**Malleable Socket Peavies**

List No.	Handles	Weight List Price	
		per Doz.	Each
124	With 2 1/2 ins. x 4 ft. select maple handle	110 lbs.	\$2.90
137	With 2 1/2 ins. x 4 ft. select hickory handle	110 lbs.	3.20
150	With 2 1/2 ins. x 4 ft. second growth maple handle	110 lbs.	3.20

**Cant Hooks**

List No.	Handles	List Price		List No.	Handles	List Price	
		Each	Each			Each	Each
188	2 1/2 ins. x 4 ft. select maple handle	\$2.20		200	2 1/2 ins. x 4 1/2 ft. select hickory handle	\$2.90	
189	2 1/2 ins. x 4 1/2 ft. select maple handle	2.30		210	2 1/2 ins. x 4 ft. 2d growth maple handle	2.60	
199	2 1/2 ins. x 4 ft. select hickory handle	2.60		211	2 1/2 ins. x 4 1/2 ft. 2d growth maple handle	2.90	

Weight per dozen, 4 ft., 85 lbs.

Weight per dozen, 4 1/2 ft., 90 lbs.

POLE RAISING TOOLS



Guarded Pike Pole

Guarded Pike Poles

List No.	Handle, Washington Fir	Weight per Doz.	List Price		List No.	Handle, Washington Fir	Weight per Doz.	List Price	
			Each	Each				Each	Each
832	10 ft., 1 3/4 ins.	100 lbs.	\$2.40		835	16 ft., 2 1/4 ins.	195 lbs.	\$3.40	
833	12 ft., 1 3/4 ins.	120 lbs.	2.50		836	18 ft., 2 1/4 ins.	210 lbs.	3.50	
834	14 ft., 1 3/4 ins.	140 lbs.	2.80		837	20 ft., 2 1/4 ins.	235 lbs.	3.80	
795	16 ft., 1 3/4 ins.	160 lbs.	3.00		798	22 ft., 2 1/4 ins.	250 lbs.	4.20	
796	12 ft., 2 1/4 ins.	165 lbs.	3.00		799	24 ft., 2 1/4 ins.	265 lbs.	4.50	
797	14 ft., 2 1/4 ins.	180 lbs.	3.20						

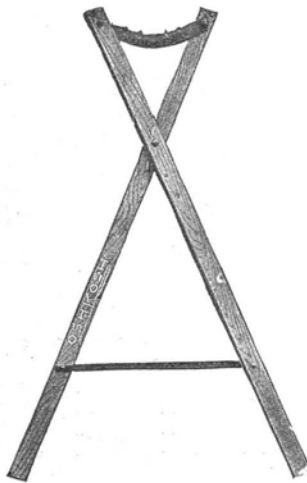

No. 842



No. 1048



No. 845



No. 1045



No. 848

Pole Supports

WOODEN JENNEY POLE SUPPORTS

List No.	Weight	List Price	
		Each	Each
842	6 ft., 2 1/2 x 3 ins.	39 lbs.	\$8.60
843	7 ft., 2 1/2 x 3 1/2 ins.	57 lbs.	9.40
844	8 ft., 2 1/2 x 3 1/2 ins.	62 lbs.	10.30

IRON JENNEY POLE SUPPORTS

List No.	Weight	List Price	
		Each	Each
1048	6 ft. pole support	32 lbs.	\$18.80
1049	7 ft. pole support	34 lbs.	13.80
1050	8 ft. pole support	53 lbs.	14.70

WOODEN MULE SUPPORT

List No.	Weight	List Price	
		Each	Each
845	6 ft., 3 1/2 in. diam.	23 lbs.	\$6.00
846	7 ft., 4 1/2 in. diam.	26 lbs.	6.90
847	8 ft., 4 1/2 in. diam.	29 lbs.	8.40

IRON MULE SUPPORT

List No.	Weight	List Price	
		Each	Each
1045	6 ft. mule pole support	32 lbs.	\$10.80
1046	7 ft. mule pole support	35 lbs.	11.60
1047	8 ft. mule pole support	39 lbs.	12.50

Standard Dead Man

WESTERN ELECTRIC PATTERN

Made of 2 x 4 inch white oak with wrought steel fork and pike and with steel bands to prevent splitting.

List No.	Weight	List Price	
		Each	Each
848	8 ft. standard dead man (Western Electric Co. pattern)	29 lbs.	\$12.50

Delivery F. O. B. Factory, Oshkosh, Wis. For warehouse deliveries write nearest house.

Telephone Apparatus and Supplies

POLE DINKEYS AND REEL WHEELS

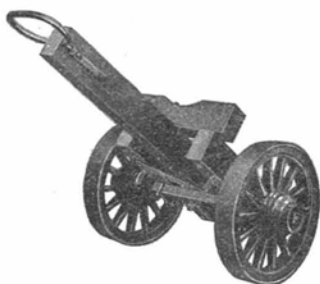

No. 306 Dicke's Heavy Pole Dinkey

Dicke's Light Pole Dinkey

A strongly built truck, especially useful for handling poles which are to be set in places that cannot be reached with a team. One man can easily handle the heaviest pole with this truck.

The woodwork is of seasoned oak, and the wheels Sarven patent, 2 feet 8 inches high, with 16 1 3/8 inch spokes. The tires are 2 1/2 x 1/4 inch, bearings 8 inches long, axles 1 3/8 inches, truck 32 1/2 inches. The entire dinkey is painted one coat before assembling and two coats afterward.

List No.	Mfr. No.		Weight Lbs.	*List Price Each
760186	305	Dicke's Light Pole Dinkey.....	165	\$50.00

Dicke's Heavy Pole Dinkey

A very strongly built dinkey that is indispensable to telegraph and telephone companies who handle large poles. The top of the carrying frame is provided with heavy pikes and is ironed with iron 3 1/2 x 1/4 inches. The bottom is cross-braced with steel 1 1/4 x 1/4 inches. The woodwork is of seasoned oak and the wheels heavy truck 25 inches in diameter, with 14 spokes 1 7/8 x 1 1/4 inches. The tires are 4 x 1/2 inches, wheel boxes of soft iron 9 3/4 x 3 inches. Hubs 8 inches in diameter, 11 1/4 inches long. The axles are 1 3/4 inches, truck 38 inches. The entire dinkey is painted one coat before assembling, and two coats afterward.

List No.	Mfr. No.		Weight Lbs.	*List Price Each
760187	306	Dicke's Heavy Pole Dinkey.....	330	\$100.00



Cable Reel Wheels

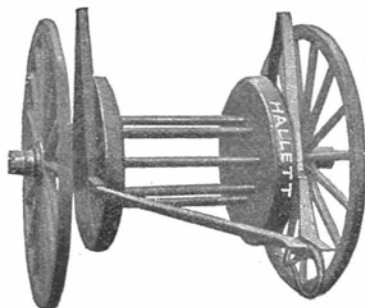

Steel Line Cart

Cable Reel Wheels

List No.		†List Price Each
760188	Pair of 6 ft. wheels, with 6 ft. reel bar.....	\$128.24
760189	One adjustable tongue.....	19.00

Steel Line Cart

List No.		†List Price Each
760190	For coiling up wire rope; by turning the tongue over the cart it brings the standard against the ground, which will raise the wheels from the ground, thus making the cart immovable while in use; made either with a steel or oak reel.....	\$104.00

\*Delivery F. O. B. Factory, Downers Grove, Ill. †Delivery F. O. B. Factory, Harvey, Ill. For warehouse deliveries write nearest house.

**PAY-OUT AND TAKE-UP REELS**

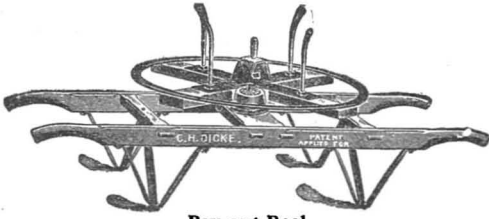

**Pay-out Reel**

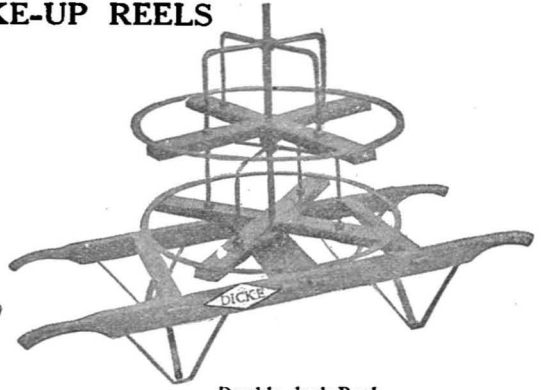

**Double-deck Reel**

	<b>Pay-out Reels</b>	*List Price
List No.		Each
760202	Dicke Pay-out Reel on barrow.....	\$16.80
760203	Dicke Double-deck Reel on barrow.....	29.70

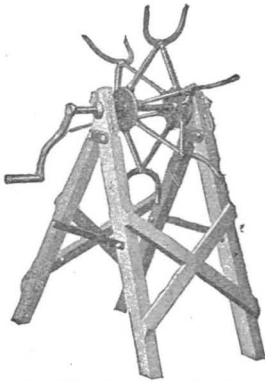

**Folding Take-up Reel**



**Folding Take-up Reel Closed**

	<b>Take-up Reels</b>	Weight	†List Price
List No.		Lbs.	Each
761270	Folding, for 12 inch coil.....	43	\$17.16
760204	Folding, for 18 inch coil.....	45	17.66
760205	Folding, for 21 inch coil.....	48	18.04
761271	Folding, for 24 inch coil.....	50	18.52

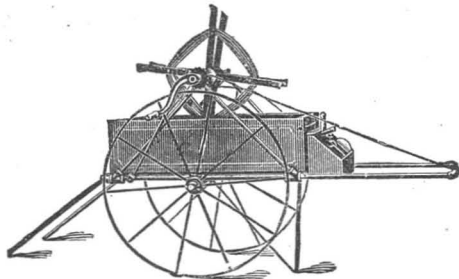

**Lineman's Cart**

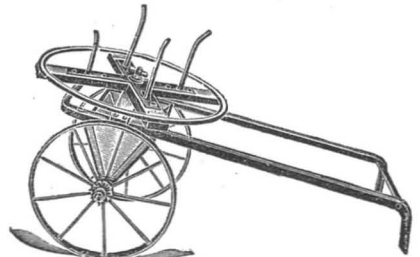

**The Wasson Reel**

	<b>Lineman's Carts</b>	List Price
List No.	Mfr. No.	Each
760208	512	Lineman's Cart with reel attached..... \$30.00
760209	...	Wasson single reel and cart..... ††24.00
760210	...	Wasson double reel and cart..... ††40.00
760211	...	Wasson single reel, less cart, with axle and tension..... ††12.00
760212	...	Wasson cart, less reel, with axle and tension..... ††16.00

\*Delivery F. O. B. Factory, Downers Grove, Ill. †Delivery F. O. B. Factory, Oshkosh, Wis. ††Delivery F. O. B. Factory, Chicago, Ill. †††Delivery F. O. B. Factory, Clinton, Ill. For warehouse deliveries write nearest house.

## BUFFALO GRIPS

(Come-alongs)

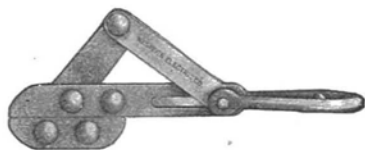

Closed

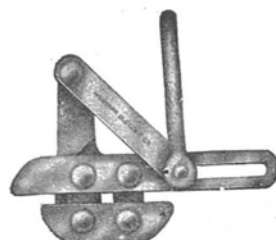

Showing Jaws Locked Open

## Western Electric

### Buffalo Grips

Made in the Following Types and Sizes

The jaws may be clamped open at any width, the grip held in one hand and the wire inserted, no matter in what position the lineman may be.

The harder the pull the firmer it grips, yet it does not injure the wire or insulation.

List No.	Grip No.	Description	Grip Only
761272	1	Extreme opening of .22 inch, holding wire from smallest size to No. 6, inclusive.	\$4.00
761273	2	Extreme opening of .35 inch, holding wire from smallest size to No. 0, inclusive.	6.40
761274	3	Extreme opening of .48 inch, holding all sizes of wire from smallest size to No. 0000, inclusive.	9.60
761275	4	Extreme opening of .52 inch, holding O. K. weatherproof wire, sizes No. 6 to No. 1, inclusive.	6.40
761276	5	Extreme opening of .68 inch, holding O. K. weatherproof wire, sizes No. 4 to No. 0000, inclusive.	8.00
761277	6	Extreme opening of .32 inch, holding O. K. weatherproof wire, sizes No. 14 to No. 8, inclusive.	4.00



With Pulley



Lineman's Tool

### Buffalo Grips with Pulleys

Made in the Following Types and Sizes

List No.	Grip No.	Description	Grip with Pulley
761278	1	Extreme opening of .22 inch, holding wire from smallest size to No. 6, inclusive. Will accommodate rope $\frac{3}{8}$ inch in diameter.	\$4.80
761279	2	Extreme opening of .35 inch, holding wire from smallest size to No. 0, inclusive. Will accommodate rope $\frac{1}{2}$ inch in diameter.	7.20
761280	3	Extreme opening of .48 inch, holding all sizes of wire from smallest size up to No. 0000, inclusive. Will accommodate rope $\frac{5}{8}$ inch in diameter.	10.40
761281	4	Extreme opening of .52 inch, holding O. K. weatherproof wire, sizes No. 6 to No. 1, inclusive. Will accommodate rope $\frac{7}{16}$ inch in diameter.	7.20
761282	5	Extreme opening of .68 inch, holding O. K. weatherproof wire, sizes No. 4 to No. 0000, inclusive. Will accommodate rope $\frac{5}{8}$ inch in diameter.	8.80

### Buffalo Lineman's Tool

List No.	Tool No.	Description	Complete Tool
761283	1	Extreme opening of .22 inch, holding wire from smallest size to No. 6, inclusive.	\$10.00
761284	2	Extreme opening of .35 inch, holding wire from smallest size to No. 0, inclusive.	13.00
761285	4	Extreme opening of .52 inch, holding weatherproof wire sizes No. 6 to No. 1, inclusive.	13.00

**PULLEY BLOCKS AND GRIPS**



Lineman's Wood Block

**Lineman's Wood Pulley Blocks**  
With Eye at Ends for Fastening Grips

List No.	Mfr. No.		Weight per Pair	List Price per Pair
761973	180	4 inch block for 1/2 inch rope.....	4 lbs.	\$5.04

We can furnish rope, but none is included in the prices listed.



Pulley Block With Eccentric Grip

**Klein's Pulley Blocks with Eccentric Grips**

List No.	Mfr. No.		Weight per Pair	List Price per Pair
761974	182	Galvanized iron 2 1/2 inch blocks, for 3/8 inch rope.....	2 3/4 lbs.	\$3.52
761975	183	Brass 2 1/2 inch blocks, for No. 12 wire and smaller, for 3/8 inch rope. 3	lbs.	8.40
761976	184	Galvanized 4 inch blocks, for No. 4 wire and smaller, for 3/8 inch rope. 6 1/2	lbs.	7.20

Rope extra.

**Self-locking Lineman's Slack Tackle**

Light steel shell blocks fitted with snubbing hook to lock in any position, also in handling a vertical load. To lock the load, simply pull the luff rope under the hook. To release, simply pull the rope. The forward block is arranged with a snap hook with spring guard.



Lineman's Slack Tackle No. 1801-30

List No.	Mfr. No.		Weight Lbs.	List Price per Set
760264	1801-30	Self-locking lineman's slack tackle, galv., furnished with 25 ft. of rope.....	2 1/2	\$5.50



Quick Samson Grip

**Quick Samson Grip**  
Strand or Messenger Wire Grips

The grip consists of a body or retaining piece in which two steel wedge shape jaws move longitudinally. These jaws are arranged so as to move in either direction simultaneously, thus opening or closing them in unison. The gripping surface of the jaws is concave, and is provided with a series of milled teeth, spread over their entire length. These teeth grip into the spirals of the strand, and being uniformly distributed over the entire length of the jaw, grip the wire at very many points, thus taking a secure hold with the pressure distributed along the entire length of the gripping surface, so that no amount of strain falls sufficiently at one point to crush or injure the wire. The tackle is attached to the two oblong rings in the body piece; these rings being arranged central, insure a straight pull. The proportions of the various parts are calculated to carry any strain that is necessary to tighten the wire and the jaws are self adjusting. Made in the following sizes:

List No.		For Strand	
		Weight Lbs. Each	List Price Each
1618-20	For 1/8 to 3/8 in. strand, gripping surface 7 in.....	8	\$16.00
1618-30	For 1/4 to 1/2 in. strand, gripping surface 7 in.....	9 3/4	17.50
1618-40	For 5/8 to 3/4 in. strand, gripping surface 9 in.....	14 1/2	19.00

PULLEY BLOCKS



Single Shell  
One Eye



Double Shell  
One Eye



Double Shell  
Double Eye



Single Shell  
Hook and Eye

Polished Brass and Malleable Iron

List No.		List Price Each
760287	Pol. Brass 2 1/4 in. shell, single, one eye, for 3/8 in. rope.....	} Prices on Application
760288	Pol. Brass 2 1/4 in. shell, single, two eyes, for 3/8 in. rope.....	
760289	Pol. Brass 2 1/4 in. shell, single, with hook, for 3/8 in. rope.....	
760290	Pol. Brass 2 1/4 in. shell, single, with hook and eye, for 3/8 in. rope.....	
760291	Pol. Brass 2 1/4 in. shell, double, one eye, for 3/8 in. rope.....	
760292	Pol. Brass 2 1/4 in. shell, double, two eyes, for 3/8 in. rope.....	
760293	Pol. Brass 2 1/4 in. shell, double, with hook, for 3/8 in. rope.....	} List Price per Doz.
760294	Pol. Brass 2 1/4 in. shell, double, with hook and eye, for 3/8 in. rope.....	
760299	Mal. Iron 2 1/4 in. shell, single, one eye, for 3/8 in. rope.....	\$2.70
760300	Mal. Iron 2 1/4 in. shell, single, two eyes, for 3/8 in. rope.....	2.70
760301	Mal. Iron 2 1/4 in. shell, double, one eye, for 3/8 in. rope.....	3.96
760302	Mal. Iron 2 1/4 in. shell, double, two eyes, for 3/8 in. rope.....	3.96
760303	Mal. Iron 3 in. shell, single, one eye, for 1/2 in. rope.....	5.40
760304	Mal. Iron 3 in. shell, single, two eyes, for 1/2 in. rope.....	5.40
760305	Mal. Iron 3 in. shell, double, one eye, for 1/2 in. rope.....	7.20
760306	Mal. Iron 3 in. shell, double, two eyes, for 1/2 in. rope.....	7.20
760307	Mal. Iron 3 1/4 in. shell, single, one eye, for 9/16 in. rope.....	6.30
760310	Mal. Iron 3 1/4 in. shell, single, two eyes, for 9/16 in. rope.....	6.30
760311	Mal. Iron 3 1/4 in. shell, double, one eye, for 9/16 in. rope.....	8.64
760312	Mal. Iron 3 1/4 in. shell, double, two eyes, for 9/16 in. rope.....	8.64
760313	Mal. Iron 4 in. shell, single, one eye, 5/8-in. rope.....	13.32
760314	Mal. Iron 4 in. shell, single, two eyes, for 5/8 in. rope.....	13.32
760315	Mal. Iron 4 in. shell, double, one eye, for 5/8 in. rope.....	16.56
760316	Mal. Iron 4 in. shell, double, two eyes, for 5/8 in. rope.....	16.56
760317	Mal. Iron 2 1/4 in. shell, single, with hook, for 3/8 in. rope.....	5.40
760318	Mal. Iron 2 1/4 in. shell, single, with hook and eye, for 3/8 in. rope.....	5.40
760319	Mal. Iron 2 1/4 in. shell, double, with hook, for 3/8 in. rope.....	6.48
760320	Mal. Iron 2 1/4 in. shell, double, with hook and eye, for 3/8 in. rope.....	6.48
760321	Mal. Iron 3 in. shell, single, with hook, for 1/2 in. rope.....	9.36
760322	Mal. Iron 3 in. shell, single, with hook and eye, for 1/2 in. rope.....	9.36
760323	Mal. Iron 3 in. shell, double, with hook, for 1/2 in. rope.....	10.80
760324	Mal. Iron 3 in. shell, double, with hook and eye, for 1/2 in. rope.....	10.80
760327	Mal. Iron 3 1/4 in. shell, single, with hook, for 9/16 in. rope.....	10.26
760328	Mal. Iron 3 1/4 in. shell, single, with hook and eye, for 9/16 in. rope.....	10.26
760329	Mal. Iron 3 1/4 in. shell, double, with hook, for 9/16 in. rope.....	12.96
760330	Mal. Iron 3 1/4 in. shell, double, with hook and eye, for 9/16 in. rope.....	12.96
760331	Mal. Iron 4 in. shell, single, with hook, for 5/8 in. rope.....	16.20
760332	Mal. Iron 4 in. shell, single, with hook and eye, for 5/8 in. rope.....	16.20
760333	Mal. Iron 4 in. shell, double, with hook, for 5/8 in. rope.....	20.52
760334	Mal. Iron 4 in. shell, double, with hook and eye, for 5/8 in. rope.....	20.52

NOTE: The sizes given on all blocks indicate the length of shell from shoulder to shoulder and not the size of sheaves.

## PULLEY BLOCKS

### Wood Pulley Blocks

#### Wood Pulley Block with Hook



Wood Pulley Block with Becket

List No.	Size Sheave, Inches	Length Shell	No. of Sheaves	Size of Rope	List Price Each
760335	1 3/4 x 1 1/2 x 3/8	3 ins.	Single	3/8 in.	\$0.70
760336	1 3/4 x 1 1/2 x 3/8	3 ins.	Double	3/8 in.	1.34
760337	1 3/4 x 1 1/2 x 3/8	3 ins.	Triple	3/8 in.	1.74
760338	2 x 1 1/2 x 3/8	3 1/2 ins.	Single	3/8 in.	.74
760339	2 x 1 1/2 x 3/8	3 1/2 ins.	Double	3/8 in.	1.44
760340	2 x 1 1/2 x 3/8	3 1/2 ins.	Triple	3/8 in.	2.00
760341	2 1/4 x 5/8 x 3/8	4 ins.	Single	1/2 in.	.84
760342	2 1/4 x 5/8 x 3/8	4 ins.	Double	1/2 in.	1.60
760343	2 1/4 x 5/8 x 3/8	4 ins.	Triple	1/2 in.	2.14
760344	3 x 3/4 x 3/8	5 ins.	Single	5/8 in.	.90
760345	3 x 3/4 x 3/8	5 ins.	Double	5/8 in.	1.74
760346	3 x 3/4 x 3/8	5 ins.	Triple	5/8 in.	2.24
760347	3 1/2 x 1 x 1 1/2	6 ins.	Single	3/4 in.	1.10
760348	3 1/2 x 1 x 1 1/2	6 ins.	Double	3/4 in.	2.00
760349	3 1/2 x 1 x 1 1/2	6 ins.	Triple	3/4 in.	2.90
760350	4 3/4 x 1 1/8 x 5/8	8 ins.	Single	1 in.	1.64
760351	4 3/4 x 1 1/8 x 5/8	8 ins.	Double	1 in.	2.84
760352	4 3/4 x 1 1/8 x 5/8	8 ins.	Triple	1 in.	4.24

NOTE: State if wanted with or without becket.



Single with Becket



Double with Becket

### Steel Tackle Block

#### Iron Bushed

List No.	Diameter Sheaves	Length Shell	No. of Sheaves	Size of Rope	List Price Each
760353	1 3/4 ins.	3 ins.	Single	3/8 in.	\$0.70
760354	1 3/4 ins.	3 ins.	Double	3/8 in.	1.34
760355	1 3/4 ins.	3 ins.	Triple	3/8 in.	1.74
760356	2 1/4 ins.	4 ins.	Single	1/2 in.	.84
760357	2 1/4 ins.	4 ins.	Double	1/2 in.	1.60
760358	2 1/4 ins.	4 ins.	Triple	1/2 in.	2.14
760359	3 ins.	5 ins.	Single	5/8 in.	.90
760360	3 ins.	5 ins.	Double	5/8 in.	1.74
760361	3 ins.	5 ins.	Triple	5/8 in.	2.24
760362	3 1/2 ins.	6 ins.	Single	3/4 in.	1.10
760363	3 1/2 ins.	6 ins.	Double	3/4 in.	2.00
760364	3 1/2 ins.	6 ins.	Triple	3/4 in.	2.90
760365	4 1/4 ins.	7 ins.	Single	7/8 in.	1.30
760366	4 1/4 ins.	7 ins.	Double	7/8 in.	2.40
760367	4 1/4 ins.	7 ins.	Triple	7/8 in.	3.50
760368	4 3/4 ins.	8 ins.	Single	1 in.	1.64
760369	4 3/4 ins.	8 ins.	Double	1 in.	2.84
760370	4 3/4 ins.	8 ins.	Triple	1 in.	4.24



Single with Becket



Double with Becket

### Hollow Shell Steel Blocks

#### Improved Roller Bushed

List No.	Diameter Sheaves	Length Shell	No. of Sheaves	Size of Rope	List Price Each
760371	1 3/4 ins.	3 ins.	Single	3/8 in.	\$1.80
760372	1 3/4 ins.	3 ins.	Double	3/8 in.	3.52
760373	1 3/4 ins.	3 ins.	Triple	3/8 in.	5.02
760374	2 1/4 ins.	4 ins.	Single	1/2 in.	1.86
760375	2 1/4 ins.	4 ins.	Double	1/2 in.	3.66
760376	2 1/4 ins.	4 ins.	Triple	1/2 in.	5.24
760377	3 ins.	5 ins.	Single	5/8 in.	2.02
760378	3 ins.	5 ins.	Double	5/8 in.	3.90
760379	3 ins.	5 ins.	Triple	5/8 in.	5.46
760380	3 1/2 ins.	6 ins.	Single	3/4 in.	2.46
760381	3 1/2 ins.	6 ins.	Double	3/4 in.	4.56
760382	3 1/2 ins.	6 ins.	Triple	3/4 in.	6.36
760383	4 1/4 ins.	7 ins.	Single	7/8 in.	2.84
760384	4 1/4 ins.	7 ins.	Double	7/8 in.	5.24
760385	4 1/4 ins.	7 ins.	Triple	7/8 in.	7.04
760386	4 3/4 ins.	8 ins.	Single	1 in.	3.66
760387	4 3/4 ins.	8 ins.	Double	1 in.	6.60
760388	4 3/4 ins.	8 ins.	Triple	1 in.	9.30

## CAPSTANS AND JACKS



Hand Capstan



Horse Capstan

## Hand Capstan

This capstan is mounted on an iron frame and fitted with a raised link, which brings the holding line on the level with the pull.

List No.		*List Price Each
760180	Style A, suitable for all ordinary use, with 5 handspikes.....	\$130.00
760181	Style A, made with horsepower attachment, complete with lever and singletree.....	150.00

## Horse Capstan

Special horse lever telephone capstan, a light, high speed tool. Keeps the ropes down close to the ground, and has no complicated back gear to get out of order.

List No.		*List Price Each
760182	Horse Capstan, with a 2 ft. drum, complete.....	\$130.00
760183	Horse Capstan, with a 2 ft. 6 in. drum, complete.....	140.00

W. E. Cable Reel Jack  
Front ViewW. E. Cable Reel Jack  
Side View

## W. E. Cable Reel Jack

Has angle iron frame  $1 \times \frac{1}{8}$  inch which is securely braced and corners reinforced. Bottom dimensions are  $16 \times 36\frac{1}{2}$  inches. Frame is approximately 24 inches high. Screw is 2 inches diameter and  $13\frac{1}{8}$  inches long. Screw head is  $5\frac{3}{4}$  inches high with groove for cable reel axle 2 inches wide and  $3\frac{1}{2}$  inches deep. With maximum extension of the screw, the height of jack would be approximately 40 inches, which will handle the largest size of usual cable reels. The hole for insertion of bar to raise and lower the screw is round and 1 inch in diameter.

List No.		Weight Lbs.	†List Price per Pair
760184	W. E. Cable Reel Jack.....	150	\$50.00

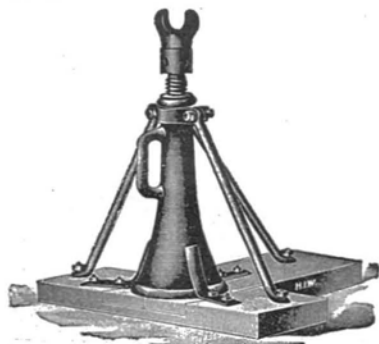
No. 4700-1  
Cable Reel Jack

\*Delivery F. O. B. Factory, Harvey, Ill. †Delivery F. O. B. Factory, New York, N. Y. For warehouse deliveries write nearest house.

## Cable Reel Jack

A pair of these jacks will support cable reels of any size while the cable is being run off. The forked head will hold a  $2\frac{1}{2}$  inch diameter shaft and will swivel to any position. The cable may be raised or lowered while it is supported on the jacks. These jacks are fitted with 2 x 16 inch locomotive jack screws braced on oak braces, or ratchet operated screws.

List No.		*List Price per Pair
4700-1	Cable Reel Jack, with jack screw.....	\$22.00
4700-2	Cable Reel Jack, with ratchet screw.....	31.00

**CABLE ROLLERS AND CARS**



"Bierce" Cable Roller—Closed



"Bierce" Cable Roller—Open  
**"Bierce" Cable Roller**



Cable Car No. 1

The "Bierce" cable roller is practically non-breakable, the frame being made of forged steel and the roller of cast iron, supported and protected on both sides by pressed steel disks, which insure the roller from injury as well as the cable, and at the same time prevent the cable or rope from catching when being pulled over the roller.

The hinged member, when thrown back, allows ample opening for the easy removal of the frame from the messenger wire and cable after the cable has been drawn and tied up in position.

The clamping device, being mounted upon the hinged member, allows the frame to be rigidly clamped in position without placing any side strain upon the messenger wire.

The construction of the frame is so arranged as to allow it to hang safely from the messenger wire before the clamp is tightened. An oil hole is provided in the roller for oiling the axle.

List No.	Bierce Cable Roller.....	Weight Lbs.	*List Price Each—	
			Plain	Galvd.
760191	Bierce Cable Roller.....	7½	\$4.20	\$4.80

**Security Messenger Cable Cars**

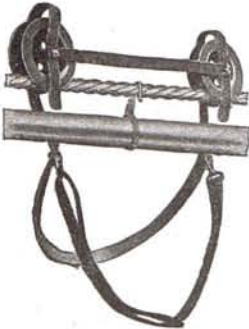

Cable Car No. 3

Cable Car No. 1 is a combined seat and table. The framework of the car is continuous, without joints, except for one elbow at each roller on the hook side, where it carries no weight. The rollers are of malleable iron, thin and light, but very strong. The seat is of wood with dovetail at each end, and its adjustable feature makes it fit any lineman and any kind of work. The table holds tools and materials.

Car No. 3 is not equipped with table, but is intended for use with a lineman's safety belt, which can easily be adjusted for height.

List No.	Mfr. No.	Description	Weight Lbs.	†List Price
				Each
760195	1	With adjustable seat and table.....	53	\$23.00
760196	1	With adjustable seat, no table.....	37	15.00
760197	3	Without safety strap.....	28	7.90

\*Delivery F. O. B. Factory, Cincinnati, O. †Delivery F. O. B. Factory, Toledo, O. For warehouse deliveries write nearest house.

**Manhole Skids and Sheaves**



A tool for leading the pulling line from the mouth of the duct to the capstan. The skids have pin holes every three inches from top to bottom so that the sheaves can be moved any place desired in the skid. Nine foot sets furnished unless otherwise ordered.

List No.		††List Price Each
760174	Nine-foot skids, per set.....	\$52.70
760175	Price for additional lengths, per foot.....	2.63

**Empire Duct Rods**

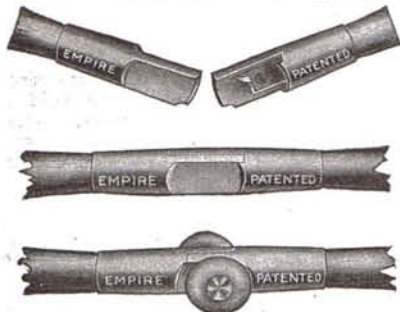

Empire Duct Rods

These rods are constructed of malleable iron machined to a perfect fit so that side or end play is avoided. The wooden rod is of the best selected straight-grained well-seasoned hickory, and is expanded in the end of the iron coupling by means of a wedge which makes it impossible to pull out.

The rods are made in two styles, without wheels and with wheels. In the wheel type the wheels are so staggered that if one axle should come in contact with an obstruction on one side of the duct the other side will remain free.

List No.	Length	List Price		List No.	per Rod
		With Wheels	Without Wheels		
760176	3 ft.	\$2.00		760178	\$1.60
760177	4 ft.	2.16		760179	1.16

\*Delivery F. O. B. New York City. †Delivery F. O. B. Factory, Chicago, Ill. ††Delivery F. O. B. Factory, Harvey, Ill. §Delivery F. O. B. Factory, Garwood, N. J. For warehouse deliveries write nearest house.

**CABLE GRIPS**



**Universal Leather Collar Protector**



**Universal Single Eye Cable Grip**



**Universal Double Eye Cable Grip**



**Universal Double Eye Split Cable Grip**

**Universal Cable Grips**

These cable grips are made in three different styles, as shown in illustrations. The single eye grip is used for attaching the pulling line to the end of the aerial or underground cable.

The double eye grip is designed for a luffing tool, to pull additional cable into a manhole after the single eye grip has been removed. It is invaluable for pulling out old underground cable, leaving it in the best of condition for future use.

The double eye split grip can be lashed on a working cable at any desired point, allowing slack to be pulled without interruption to the service. To determine size of Universal Cable Grips to order, refer to table of measurements.

**Table of Measurements**

Cable Grip Size	Cable Diameter, Inches	Cable Grip Size	Cable Diameter, Inches
1/2 in.	For 1/2 in. to 5/8 in.	2 in.	For 2 in. to 2 3/8 in.
3/4 in.	For 3/4 in. to 7/8 in.	2 1/2 in.	For 2 1/2 in. to 2 7/8 in.
1 in.	For 1 in. to 1 1/8 in.	3 in.	For 3 in. to 3 3/8 in.
1 1/2 in.	For 1 1/2 in. to 1 7/8 in.		

**List Prices and Data**

Single Eye Grip			Single Eye Grip		
List No.	Size	*List Price Each	List No.	Size	*List Price Each
741500	1/2 x 24 ins.	\$3.00	741507	1/2 x 36 ins.	\$5.00
741501	3/4 x 24 ins.	3.50	741508	3/4 x 36 ins.	5.50
741502	1 x 24 ins.	4.00	741509	1 x 36 ins.	6.00
741503	1 1/2 x 24 ins.	4.50	741510	1 1/2 x 36 ins.	6.50
741504	2 x 24 ins.	5.00	741511	2 x 36 ins.	7.00
741505	2 1/2 x 24 ins.	5.50	741512	2 1/2 x 36 ins.	7.50
741506	3 x 24 ins.	6.00	741513	3 x 36 ins.	8.00
Double Eye Grip			Double Eye Split Grip		
741514	3/4 x 18 ins.	\$5.00	741520	3/4 x 18 ins.	\$6.00
741515	1 x 18 ins.	6.00	741521	1 x 18 ins.	7.00
741516	1 1/2 x 18 ins.	7.00	741522	1 1/2 x 18 ins.	8.00
741517	2 x 18 ins.	8.00	741523	2 x 18 ins.	9.00
741518	2 1/2 x 18 ins.	9.00	741524	2 1/2 x 18 ins.	10.00
741519	3 x 18 ins.	10.00	741525	3 x 18 ins.	11.00

**Universal Leather Collar Protector**

The Universal Leather Collar Protector is for use with single eye grips only. It will prolong the life of the cable grip, as it protects the point of greatest wear.

**Single Eye Grip For 24 Inch and 36 Inch**

List No.	Size	*List Price Each	List No.	Size	*List Price Each
741526	1 in.	\$1.50	741529	2 1/2 ins.	\$1.80
741527	1 1/2 ins.	1.60	741530	3 ins.	1.90
741528	2 ins.	1.70			

\*Delivery F. O. B. Syracuse, N. Y. For warehouse deliveries, write nearest house.

LINEMEN'S STRAPS AND BELTS



No. 5200 Plain Tool Belt



No. 5205 Double Tool Belt, With Rings

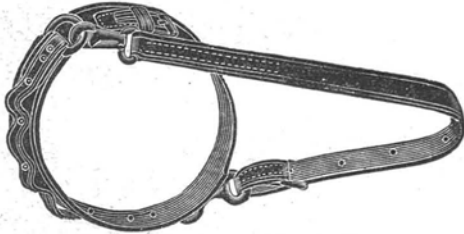

No. 5206-1A Belt and Safety Strap



No. 5202 Single Tool Belt, With Rings

List No.	Belt and Safety Strap	Weight Lbs.	List Price Each
5206-1A	2 1/4 in. belt, including safety strap. . . . . The safety strap is 1 3/4 inches wide and 6 feet long, and provided with a snap at each end.	3 1/2	\$6.20

Belt With Rings

5202	2 1/4 in. belt, with rings for attaching safety strap . . . . .	1 5/6 lbs.	\$3.10
5204	3 1/2 in. belt, with rings for attaching safety strap . . . . .	1 5/6 lbs.	3.70
5205	2 1/4 in. double belt, with rings for attaching safety strap . . . . .	2 lbs.	4.20

Plain Tool Belt

5200	Plain Tool Belt, 2 1/4 in. . . . .	14 2/3 oz.	\$2.50
------	------------------------------------	------------	--------

NOTE: When ordering belts, state if wanted for 38, 40, 42, 44, or 46 inch waist.



No. 5106 Leather Pouch

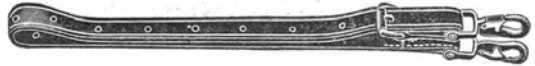

No. 5253 Safety Strap



No. 5303-1 Jack or Vise Strap



No. 5308 Combined Safety and Jack Strap

Combined Safety and Jack Strap

List No.	Combined Safety and Jack Strap	Weight Lbs.	List Price Each
5308	1 3/4 in. strap, fixed snap on one end, roller snap at other. . . . .	2 1/4	\$3.70

Jack or Vise Strap

5303-1	Regular Jack Strap, for vise, 1 1/4 in. x 5 1/2 ft. . . . .	3/4 lbs.	\$2.20
--------	---	----------	--------

Safety Strap

5250	1 3/4 in. x 6 ft. Safety Strap, with japanned snaps . . . . .	2 1/2 lbs.	\$3.20
5251	1 3/4 in. x 6 1/2 ft. Safety Strap, with roller snaps . . . . .	2 1/2 lbs.	3.80
5252	1 3/4 in. x 6 1/2 ft. Safety Strap, with swivel roller snaps . . . . .	2 1/2 lbs.	4.20
5253	2 in. x 6 ft. Safety Strap, with roller snaps . . . . .	2 3/4 lbs.	4.50

Leather Pouch

5106	Made with loop to slip into belt, for holding screw, etc. . . . .	6 2/3 oz.	\$1.10
------	---	-----------	--------

NOTE: When ordering belts, please state if wanted for 38, 40, 42, 44, or 46 inch waist.

LINEMEN'S CLIMBERS



No. 1901  
Eastern



No. 5301-1  
Eastern



No. 1900-1903  
Eastern



No. 5300-1  
Western



No. 1902  
Western

Klein's Pole Climbers

List No.		Length	Weight per Pair	List Price per Pair
1900	Eastern—without straps, riveted strap loops.....	15 to 18 in.	3 <sup>3</sup> / <sub>4</sub> lbs.	\$4.50
1903	Special light weight Eastern riveted loops—without straps	15 to 16 <sup>1</sup> / <sub>2</sub> in.	2 <sup>3</sup> / <sub>4</sub> lbs.	4.50
1901	Eastern—without straps, punched strap loops.....	15 to 18 in.	3 <sup>5</sup> / <sub>8</sub> lbs.	4.00
1902	Western—without straps.....	15 to 18 in.	2 <sup>5</sup> / <sub>8</sub> lbs.	3.50

NOTE: When ordering climbers, always specify length wanted by half inch variation. The steel in Linemen's Eastern Pattern Climbers is made to special order of a springy, durable quality, forged to the right thicknesses for safety and lightness. The gaffs are of tool steel set into the shank and never loosen. When worn down, however, they can be removed and new gaffs set in place.

The lines of form make them well fitting and comfortable. Quality and workmanship is the best in either. The only difference is in the loop through which the straps pass. The No. 381 and No. 381L have the loops riveted into the shank, while in the No. 382 they are punched out of the metal of the shank. No. 381L is the pattern of No. 381, but made lighter than the standard weight.

If straps are wanted with climbers, mention it in the order. We never send straps unless it is mentioned.

Climber Straps

List No.		Weight per Doz. Sets	List Price per Pair
5301-1	Straps for Eastern Climbers, with plain leather pads.....	15 lbs.	\$2.80
5301-2	Straps for Eastern Climbers, with sheep-lined pads.....	16 lbs.	3.20
5301-3	Straps for Eastern Climbers, with felt-lined pads.....	16 lbs.	3.20
5300-1	Straps for Western Climbers, with plain leather pads.....	15 lbs.	2.80
5300-2	Straps for Western Chambers, with sheep-lined pads.....	16 lbs.	3.20
5300-3	Straps for Western Chambers, with felt-lined pads.....	16 lbs.	3.20

Eastern Climber straps set consists of two upper straps with 4 x 4 leather pads and two lower straps as shown in cut.

Western Climber straps set consists of two upper straps with oval plain leather pads and two lower straps as shown in cut.

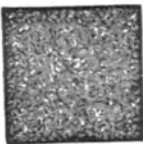

Soft Pads

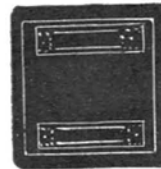

Plain Leather Pads

Strap Pads

List No.		Weight per Doz. Sets	List Price per Pair
8200	Strap Pads, sheep lined, 4 x 4 inches.....	3 lbs.	\$1.50
8201	Strap Pads, felt lined, 4 x 4 inches.....	3 lbs.	1.50
8202	Strap Pads, plain leather, 4 x 4 inches.....	3 lbs.	1.00

**WIREMEN'S PLIERS**



Klein's Extra Long Nose Pliers Without Side Cutters



Klein's Extra Long Nose Pliers (Side Cutting)

**Klein's Extra Long Oval Nose Pliers**

List No.	Size Inches		Weight per Doz.	List Price Each	List No.	Size Inches		Weight per Doz.	List Price Each
301-5	5	Without Cutter	2¾ lbs.	\$1.60	203-5	5	With Side Cutter	2¾ lbs.	\$1.70
301-6	6	Without Cutter	3 lbs.	1.70	203-6	6	With Side Cutter	3 lbs.	1.80
301-7	7	Without Cutter	3¼ lbs.	1.90	203-7	7	With Side Cutter	3¼ lbs.	2.00



Long Needle Nose Pliers

**Klein's Extra Long Needle Nose Pliers**

List No.	Size Inches		Weight per Doz.	List Price Each
303-5	5	Without Cutter	2½ lbs.	\$1.60
303-6	6	Without Cutter	3 lbs.	1.70
303-7	7	Without Cutter	3¼ lbs.	1.90

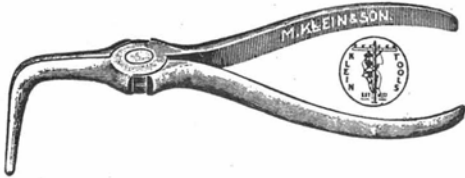

Klein's Extra Long Curved Nose Pliers

List No.		Weight per Doz.	List Price Each
302-6	6 inch extra long curved nose pliers.....	2¾ lbs.	\$1.90

**Klein's Extra Long Curved Nose Pliers**

List No.		Weight per Doz.	List Price Each
202-5	5 inch diagonal cutting pliers.....	4 lbs.	\$2.00
202-6	6 inch diagonal cutting pliers.....	4¼ lbs.	2.20

**Klein's Oblique Diagonal Cutting Pliers**



Extra Long Flat Nose Pliers Without Side Cutters

**Klein's Extra Long Flat Nose Pliers Without Side Cutters**

List No.	Size Inches		Weight per Doz.	List Price Each
305-5	5	Without Cutter	3 lbs.	\$1.60
305-6	6	Without Cutter	3½ lbs.	1.70
305-7	7	Without Cutter	3¾ lbs.	1.90

Telephone Apparatus and Supplies

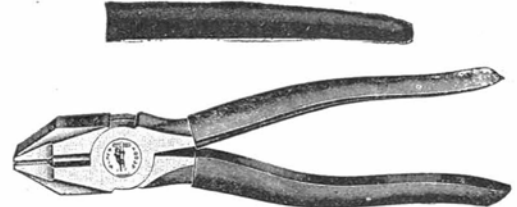

Rubber Sleeves for Insulating Pliers

**Rubber Sleeves For Insulating Pliers**

Made of Pure Gum Soft Rubber

List No.		Weight per Doz.	List Price Each
2400-6	For 6-in. pliers, per pr.	2¾ lbs.	\$1.00
2400-7	For 7-in. pliers, per pr.	3¼ lbs.	1.00
2400-8	For 8-in. pliers, per pr.	3¾ lbs.	1.00

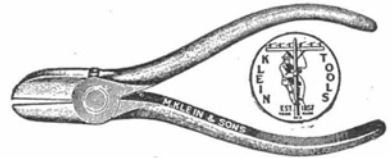

Klein's Oblique Diagonal Cutting Pliers

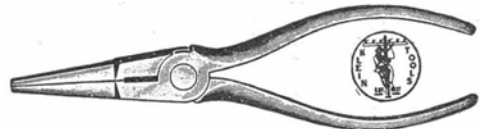

Extra Long Flat Nose Pliers With Side Cutters

**Klein's Extra Long Flat Nose Pliers—Side Cutters**

List No.	Size Inches		Weight per Doz.	List Price Each
206-5	5	With Side Cutter	3¼ lbs.	\$1.70
206-6	6	With Side Cutter	3½ lbs.	1.80
206-7	7	With Side Cutter	3¾ lbs.	2.00

**SPLICING CLAMPS**

The splicing clamp is one of the most important tools in the lineman's kit, and as electrically and mechanically good joints are of the most importance in a line, it is evident that the tools selected to do this work should have careful consideration. The following illustrations show our different styles and the sizes of wire for which they are fitted. The handles have a spring temper and will not bend out of shape after being closed on the wire.



No. 102-1



No. 102-3

**Baby Pattern for Telephone Work**

List No.	Length Inches	Wt. per Doz., Lbs.	List Price Each
102-1 For Nos. 10, 12, 14, and 16 copper wire; 12, 14, 16, 18 iron wire.	7	4½	\$2.70
102-3 For Nos. 6, 8, 10, 12 and 14 iron wire, 4, 6, 8, 10 and 12 copper wire	10½	14¾	3.40



No. 102-4



No. 102-2

**For Electric Light, Telegraph and Railroad Work**

List No.	Length Inches	Wt. per Doz., Lbs.	List Price Each
102-2 For Nos. 4, 6, 8 and 10 iron wire, or Nos. 2, 4, 6 and 12 copper wire	10½	14½	\$3.20
102-4 For Nos. 0, 2 and 4 copper wire.	10¾	14¾	3.20



Nos. 105-6 and 105-7

**For Telephone, Telegraph, Railway, Light and Power Work**

List No.	Length Inches	Wt. per Doz., Lbs.	List Price Each
105-6 For sleeves Nos. 8, 10, 12 and 14 B&S gauge or 10, 12, 14, 16 B. W. G.	10½	14	\$3.20
105-7 For sleeves Nos. 6, 8, 10 and 12 B&S gauge or 8, 10, 12, 14 B. W. G.	10½	14	3.20

**Combination Wire and Sleeve Clamps**

For Telephone, Telegraph, Railway, Electric Light and Power Work



No. 132-2



No. 132-5

List No.	Length Inches	Wt. per Doz., Lbs.	List Price Each
132-2 Has 4 round holes for Nos. 8, 10, 12, 14 iron wire, 6, 8, 10, 12 copper wire and 3 double holes for Nos. 10, 12, 14 B&S sleeves, or 12, 14 and 16 B. W. G. sleeves.	9	10¼	\$3.50
132-5 Has six round holes for Nos. 6, 8, 9, 10, 12, 14 and 16 iron wires, or Nos. 4, 6, 8, 9, 10, 11, 12 and 14 copper wires. Five double holes for twisting sleeve joints Nos. 6, 8, 9, 10, 11, 12 and 14 B&S copper sleeves, or Nos. 8, 9, 10, 11, 12, 14 and 16 iron sleeves.	11¼	17¾	4.00



No. 132-3



No. 132-4

List No.	Length Inches	Wt. per Doz., Lbs.	List Price Each
132-3 Has 5 round holes and 4 double holes for Nos. 6, 8, 10, 12 and 14 iron wire, 4, 6, 8, 10 and 12 copper wire, and 8, 10, 12 and 14 B&S sleeves, or 10, 12, 14 and 16 B. W. G. sleeves.	10¾	15½	\$3.60
132-4 Same style only arranged for different sleeves. For Nos. 6, 8, 10 and 12 B&S sleeves, or 8, 10, 12 and 14 B. W. G. sleeves, 6 to 14 iron wire, and 4 to 12 copper wire.	10¾	15½	3.60

## Western Electric TIE WRENCH

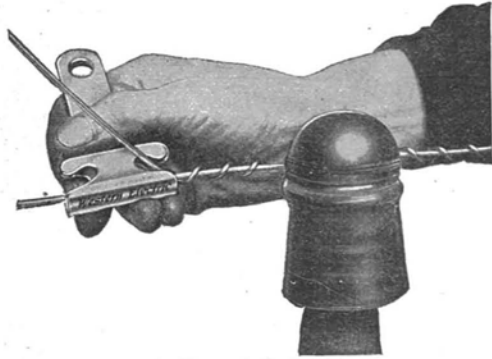

**Method of "Tying In" with Tie Wrench**

the line wire to cause a break which may seriously interrupt the service, while if the tie wires are put on with the fingers it is impossible to wrap them tightly enough to hold the line wire firmly when subjected to sleet loads or the failure of an adjacent span support or break, and also to leave the tie without projecting ends.

The Western Electric Tie Wrench above illustrated is designed to wrap the tie wire evenly and firmly around the line wire and at the same time leave no projecting ends. A tie can also be put on much quicker with this wrench than with either the fingers or pliers.

This wrench is furnished in three sizes as follows:

List No.	Size Line Wire Nos.	List Price Each
8	8-10 B.&S.	\$3.00
12	12 B.&S.	3.00
14	14 B.&S.	3.00



Western Electric Tie Wrench

In tying line wires to the insulators it is imperative that the tie wires be given a specified number of complete turns or wraps around the line wire on each side of the insulator, and that in so doing this the line wire is not scored or nicked in the operation.

It is the habit of many linemen to use their fingers, a pair of pliers or even connectors in "tying in," but it is universally conceded that pliers or connectors frequently damage the wire and it takes but one nick in



No. 3105-20

### Splicing Wrench

List No.		*List Price Each
3105-20	Tie wire, sleeve, and splicing wrench for tying in with No. 7 to 11 copper wire, for splicing Nos. 8 and 9 iron wire and for twisting Nos. 9 and 10 B.&S. gauge sleeves.....	\$2.50

**NOTE:** No. 3105-20 for use along with the splicing clamp.

\*Delivery F. O. B. Factory, Chicago, Ill. For warehouse deliveries write nearest house.



Steel Lag Screw Wrench



Combination Lag Screw Wrench

### Klein's Steel Lag Screw Wrench

This wrench is forged from select bar steel. The jaw is made tapering, allowing it to take any ordinary size machine bolts, nuts, or lag screws, from  $\frac{3}{8}$  inch to  $\frac{5}{8}$  inch. The hook is a means of attaching the wrench to the tool belt, and it serves to keep the heads of bolts within the jaws of the wrench when in use.

List No.		Wgt. Length per Doz.	List Price Each
3110-20	Steel Lag Screw Wrench, full polished.....	11 $\frac{1}{2}$ in. 20 lbs.	\$2.80

### Klein's Combination Lag Screw Wrench

This wrench is forged from select bar steel. The slot in this wrench is formed in a cross shape, and will fit machine bolts, nuts, or lag screws, from  $\frac{3}{8}$  inch to  $\frac{5}{8}$  inch. The small end of the wrench is arranged for  $\frac{1}{8}$  inch machine bolts or lag screws, the round hole allowing the end of a bolt to come through as the nut is run on.

3109-20	Combination Lag Screw Wrench, full polished.....	13 $\frac{1}{2}$ 20 lbs.	\$3.30
---------	--	--------------------------	--------

Telephone Apparatus and Supplies

## RUBBER GLOVES

### Pure Rubber Gloves



Seamless Glove—Unlined

The seamless type gloves are made of red rubber. Only the best selected pure fine Para rubber is used in their manufacture. Being seamless, they have no imperfection on account of laps or joints. They are easily cleaned or dried by turning, as they have no fabric or lining to interfere. They are flexible and serviceable, while the safety is measured by the tests to which each pair is subjected before leaving the factory.

The sizes are standard rubber glove sizes and compare with Nos. 14 and 15 of the coated seam glove. The standard weights are tested for about 4,000 volts, heavy weights about 10,000 volts. The heavy palm have the standard weight gauntlet, but palm of this glove is tested for about 10,000 volts. Length, 11 to 15 inches.

List No.	Size No.	Length Inches	Style	List Price per Doz. Pairs
760542	10	12	Standard	\$45.00
760548	11	12	Standard	45.00
760545	10	15	Standard	52.50
760551	11	15	Standard	60.00
760543	10	12	Ex. Heavy Finger & Palm	60.00
760550	11	12	Ex. Heavy Finger & Palm	60.00
760546	10	14	Ex. Heavy Finger & Palm	75.00



Without Gauntlet



With Gauntlet

### Rubber Gloves, Cloth Lined

#### Palm and Fingers Reinforced

The seam rubber glove is made from selected rubber and is cloth lined. The heavy weight gloves listed below are subjected to a test of 9,000 volts before leaving factory. To determine size required, measure hand around knuckles, and then add 6 inches to measurement; i.e., if hand should measure 8 inches, order size No. 14 for close fit, or No. 15 for loose fit.

List No.	Style	Size	Extra Heavy Weight, Without Gauntlet	List Price per Doz. Pairs
760554	Short	13 to 15	.....	\$50.62
760555	Short	16	.....	55.70
760556	Short	17	.....	65.82

#### Extra Heavy Weight, With Gauntlet

List No.	Style	Length Gauntlet	Size	List Price per Doz. Pairs
760558	Half Long	4½ inch	13 to 15	\$60.74
760559	Half Long	4½ inch	16	65.82
760560	Half Long	4½ inch	17	70.88

**TOOL BAGS**



No. 5108, Leather Tool Bag

**Inspector's Leather Tool Bag, Harness Leather**

This bag is a combination of all the good features of the various common leather bags. It is made of harness leather and will stand rough and hard usage and still always look well. It has a shoulder strap combined with a pad and hand strap; also a saw and bit holder. The bottom is three ply and is studded with steel studs. Retaining straps pass clear around the bag so that it may be loaded to the limit of its capacity and be securely held intact. All seams are sewed with hot waxed linen thread, lock stitched. The leather used does not absorb moisture.

List No.	Size	Material	Wgt. Lbs.		List Price	
			Each	Each	Each	Each
5108-14	14 x 8 in.	harness leather	3		\$9.90	
5108-16	16 x 8 in.	harness leather	4 1/8		10.40	
5108-18	18 x 8 in.	harness leather	4 1/2		11.00	
5108-20	20 x 8 in.	harness leather	5 1/8		11.50	
5108-22	22 x 8 in.	harness leather	6		12.00	
5108-24	24 x 8 in.	harness leather	7 1/4		12.80	

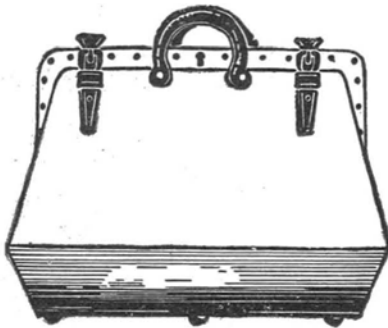

Canvas Tool Bag



No. 5101-15

**Lineman's Canvas Tool Bag, Leather Bottom**

List No.	Size Inches	Wgt. Lbs. Each	List Price Each	List No.	Size Inches	Wgt. Lbs. Each	List Price Each
5102-22	22 in.	4	6.90	5102-14	14 in.	3	5.30
5102-20	20 in.	3 3/8	6.30	5102-12	12 in.	2 5/8	5.10
5102-18	18 in.	3 3/4	6.00				

**Inspector's Black Leather Tool Bag**

This bag is made with shoulder straps entirely of leather, tongue and buckle fastenings, convenient for inspector, wireman or lineman.

List No.	Size	Wgt. Lbs.		List Price	
		Each	Each	Each	Each
5101-15	15 ins. long, 12 ins. high	3		\$8.00	
5101-20	20 ins. long, 12 ins. high	3 3/4		10.50	

MISCELLANEOUS TOOLS



Bell Hanger's Gimlet Bit

Bell Hanger's Gimlet Bits

List No.	Length Inches	Size Inches	List Price per Doz.	List No.	Length Inches	Size Inches	List Price per Doz.	List No.	Length Inches	Size Inches	List Price per Doz.
760693	12	1/4	\$6.24	760696	18	1/4	\$8.74	760699	24	1/4	\$11.24
760694	12	5/16	6.86	760697	18	5/16	9.36	760700	24	5/16	11.86
760695	12	3/8	7.50	760698	18	3/8	10.00	760701	24	3/8	12.50

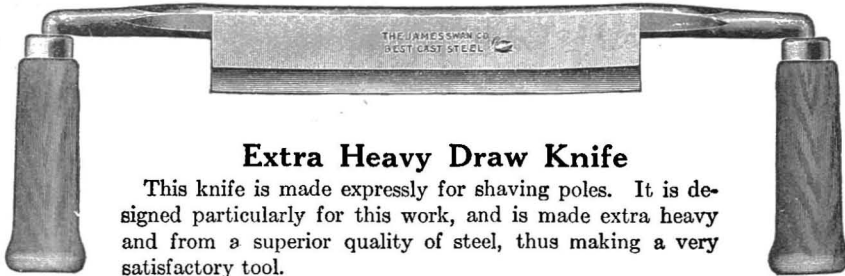

Extra Heavy Draw Knife

This knife is made expressly for shaving poles. It is designed particularly for this work, and is made extra heavy and from a superior quality of steel, thus making a very satisfactory tool.

Length of blade, inches	8	9	10	11	12	14
List No.	760702	760703	760704	760705	760706	760707
List per doz.	\$23.76	\$26.72	\$29.70	\$32.66	\$35.64	\$41.58

Framing Chisels



Bevel Back Framing Chisel

Width of blade, ins.	1/2	5/8	3/4	7/8	1	1 1/8	1 1/4	1 1/2	1 3/4	2
List No.	760708	760709	760710	760711	760712	760713	760714	760715	760716	760717
List per doz.	\$8.52	\$9.00	\$9.44	\$9.92	\$10.40	\$11.34	\$11.34	\$12.30	\$13.70	\$15.12



Electrician's Hammer



Lineman's Axe



Hand Axe

Electrician's Hammer

List No.	List Price Each
760718	9 oz. electrician's tack hammer . . . \$0.94

Lineman's Axe

List No.	List Price Each
760719	3 1/2 lb. with handle . . . \$1.86
760720	5 lb. with handle . . . 2.08

Hand Axe

List No.	Mfr. No.	Weight	Bit	List Price Each
760721	640	1 lb. 8 oz.	4 ins.	\$1.18
760722	641	1 lb. 12 oz.	4 1/2 ins.	1.30
760723	642	2 lb. 2 oz.	5 ins.	1.40
760724	643	2 lb. 8 oz.	5 1/2 ins.	1.50
760725	644	2 lb. 14 oz.	6 ins.	1.66
760726	645	3 lb. 4 oz.	6 1/2 ins.	1.86
760727	646	3 lb. 12 oz.	7 ins.	2.08
760728	647	4 lb. 4 oz.	7 1/2 ins.	2.50

**TREE TRIMMERS**

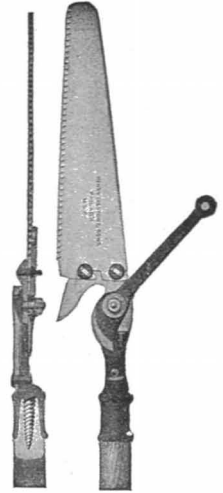
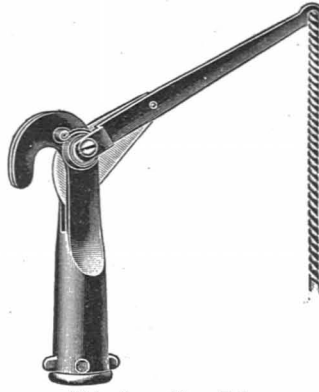
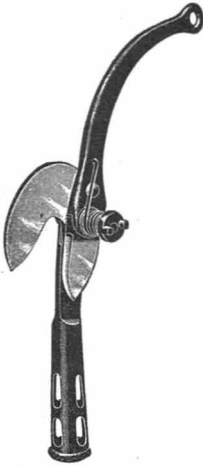

Standard Tree Trimmer

New Giant Tree Trimmer

Telephone Tree Trimmer

Little Giant

**Standard Tree Trimmer**

List No.	Length	Approx. Wt. Each		*List Price Each	List No.	Length	Approx. Wt. Each		*List Price Each
		lbs.	ozs.				lbs.	ozs.	
760275	4-ft. Standard.....	2	8	\$1.00	760278	10-ft. Standard.....	4	4	\$1.26
760276	6-ft. Standard.....	3	2	1.16	760279	12-ft. Standard.....	5	0	1.38
760277	4-ft. Standard.....	4	0	1.26					

**New Giant Tree Pruner**

List No.	Description	Size	Weight	*List Price Each
761655	New Giant Tree Pruner without pole.....	15 ins. high	2 lbs., 4 ozs.	\$4.00

**Telephone Tree Trimmer**

List No.	Description	Approx. Wt. Each	*List Price Each
760280	Heads only, without pole and rope.....	1½ lbs.	\$2.00

**“Little Giant” Pruning Hook and Saw**

List No.	Description	*List Price Each
760281	Hook and saw (without pole), length of blade 12 inches.....	\$3.88
760282	Hook only (without pole).....	1.88

†Delivery F. O. B. Factory, Williamsport, Pa. \*Delivery F. O. B. Factory, New York City. For warehouse deliveries write nearest house.

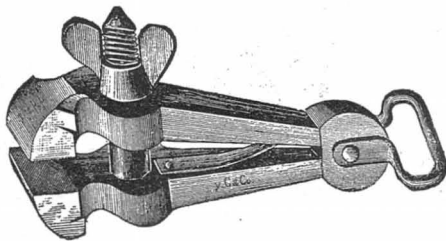

Lineman's Vise

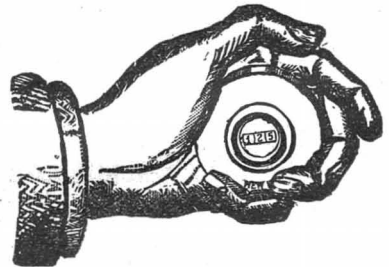

Pole Counter

**LINEMAN'S VISES**

List No.	Description	List Price Each
760267	5½ in. lineman's vise, with loop.....	\$1.70
760268	6 in. lineman's vise, with loop.....	2.10

**POLE COUNTER**

List No.	Description	List Price Each
0	Pole counter, records 1 to 1000.....	\$4.04
1	Pole counter, records 1 to 10,000.....	5.64

Telephone Apparatus and Supplies

MISCELLANEOUS POCKET TOOLS

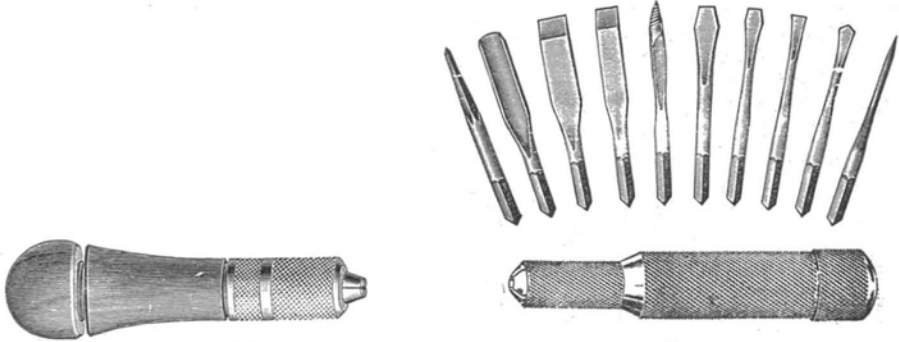

Hollow Handle Tool Sets

List No.	Mfr. No.	Description	Length of Handle	Length of Tool	†List Price
760272	4	Cocobolo wood, jaws and shell nickeled 10 tools.....	6¼ in.	2½ in.	\$2.00
761855	600	Combination handle, complete with 20 tools.....	5 in.	2¼ in.	1.50

\*Delivery F. O. B. Factory, Trenton, N. J. †Delivery F. O. B. Factory, Downers Grove, Ill. ††Delivery F. O. B. Factory, New York City. †††Delivery F. O. B. Factory, Miller Falls, Mass. For warehouse deliveries write nearest house.

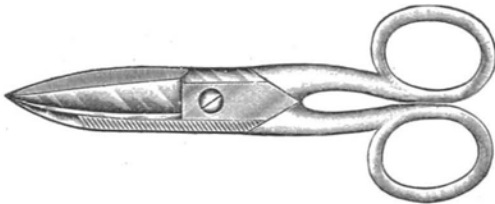

Electrician's Scissors

"Xela" Electrician's Scissors



No. 1550-1—Single Blade

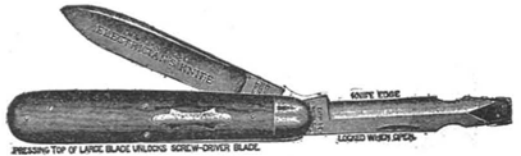

No. 1550-2—Double Blade

List No.	Mfr. No.	Description	Finish	Weight Each	Size	List Price Each
761049	2100-5	Electrician's Scissors.....	Nickel Plated	2¾ oz.	5 in.	\$1.00

"Xela" Electrician's Knife and Screw Driver

These knives have a screw driver blade which locks when open, thus preventing closing on the hand. The screw driver blade is ground to a knife edge, which makes it suitable for stripping insulated wire. The point of the blade is made for a screw driver and is drawn to a satisfactory temper for setting screws. The handles are made of rosewood with brass rivets. The bolsters are of German silver.

List No.	Mfr. No.	Description	Weight	List Price
761050	1550-1	Single Blade Electrician's Knife.....	1 5/6 oz.	\$1.00
761051	1550-2	Double Blade Electrician's Knife.....	2 5/6 oz.	1.50

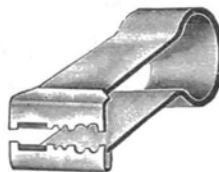

P. & G. Wire Skinner

P. & G. Wire Skinner

This wire Skinner does away with the dangerous pocket knife. Skins wire clean at one stroke. Does not nick, mar, or injure the wire. Skins or splits any kind of insulated wire, including weatherproof, rubber covered, cotton covered, braided, lead covered, single and duplex wire, lamp cord, etc.

List No.	Mfr. No.	Description	Weight	List Price
760274	2300-10	Wire Skinner.....	4 oz.	\$1.50

POCKET TOOL KITS



No. 1304-2

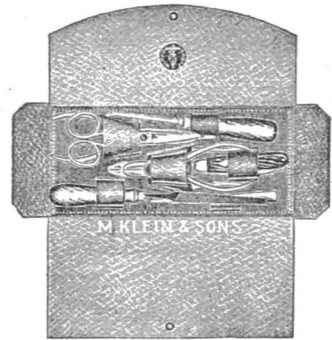

No. 1301-2

These tool kits are recommended especially for every electrician, mechanic, repairman, inspector, lineman, signalman and supervisor.

List No.		List Price Each
1304-2	Genuine leather case, contains a selection of Klein tools such as have been found particularly desirable by electricians and wiremen on switchboard and telephone work. It is of convenient pocketbook style, with firm metallic clasp, and measures 4 x 9 ins. It contains the following tools: One single blade "Xela" electrician's knife, one 5 in. Klein special side cutting pliers, one 5 in. Klein oblique diagonal pliers, one 6 in. Klein long nose side cutting pliers, one 3½ in. blade nickel-plated screw driver and one pair 5½ in. "Xela" electrician's scissors, and one 3½ in. file and handle. Weight, 1¾ lbs. . . . .	\$10.00
1301-2	Genuine leather case, durable and compact, 8 ins. long, 3½ ins. in width and 2 ins. high when closed. Furnished in either russet or black leather. The kit contains seven tools, all of which are in constant use. Each one is of superior quality and will give excellent service. They are Klein's 7 in. special side cutting pliers, hand forged, with knives of guaranteed quality; 5 in. nickel-plated "Xela" scissors; double-bladed knife screw driver and wire scraper combined; 3 in. half-round mill file and handle; 2½ in. "Xela" screw driver, 3½ in. nickel-plated tweezer and 2 ft. 4 fold boxwood rule. Weight, 1½ lbs.	12.00

Metal Tool Kits

These kits are made of prepared steel, but are no heavier than other bags and suit cases, their average weight being between 5 and 11 lbs., depending on size.

They are built to stand the wear and tear of hardest usage, being reinforced throughout, and fitted with brass side catches, strong two-tumbler Corbin locks, steel leather-covered handles, so riveted that they cannot pull out, and are protected by solid corner irons.

Finished in a durable baked enamel of brown or black, they present an appearance neat and attractive, and look like leather traveling bags or suit cases. Disappearing and waterproof hinges give smooth carrying surface with no rivets showing. Material, special construction, and overlapping features make these kits waterproof, fire, oil and weatherproof. These kits are also thief-proof because they can be locked, chained if desired, and cannot be cut open. Heavy material can be carried without buckling or changing shape of bag. There is no strain on hinges or locks as entire weight is on body of bag. Double seamed, electric welded and reinforced throughout.



Standard Kit with or without Tray

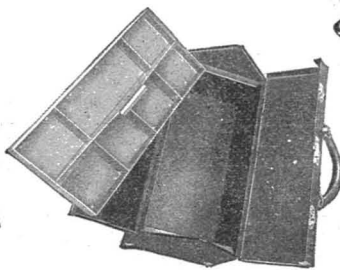

Standard Kit with Tray

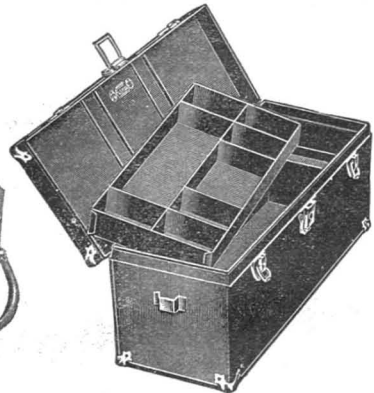

Electrician's Case with Tray

Standard Kits

For Electrical Workers, Mechanics, Railroad Men, Construction Men, Installation Men and Contractors

List No.	Style	STYLE X			Weight	List Price
		Length	Width	Height		
86678	X	14 ins.	7 ins.	9 ins.	4½ lbs.	\$5.26
86676	DD	16 ins.	9 ins.	11 ins.	5½ lbs.	5.64
86680	D	18 ins.	10 ins.	13 ins.	6¾ lbs.	6.00
86681	E	20 ins.	11 ins.	13 ins.	7¼ lbs.	6.38
86682	F	22 ins.	11 ins.	13 ins.	10½ lbs.	13.76

With tray for bag shape only for screws, nuts and small parts, add 54 cents extra each size.

Telephone Apparatus and Supplies

**EXTENSION CHUCKS AND SCREW DRIVERS**

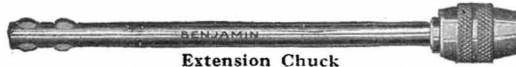

Extension Chuck

**Extension Chuck**

List No.	Length	Weight per Doz.	List Price per Doz.
S-21	5 ins.	1 3/4 lbs.	\$4.84
S-22	10 ins.	2 5/8 lbs.	5.64



Friction Drive

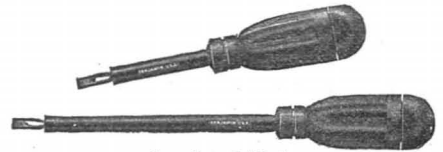

Insulated Blade

**FRICITION DRIVE SCREW DRIVERS**

List No.	Length of Blade	Diam. of Blade	Std. Pkg.	Wt. Lbs. per Doz.	Price per Doz.	List No.	Length of Blade	Diam. of Blade	Std. Pkg.	Wt. Lbs. per Doz.	Price per Doz.
A-33	3 ins.	3/16 in.	144	1 1/8	\$3.22	B-46	6 ins.	1/4 in.	144	3 3/8	\$6.44
A-34	4 ins.	3/16 in.	144	2	4.02	B-48	8 ins.	1/4 in.	144	3 3/4	7.24
A-35	5 ins.	3/16 in.	144	2 1/8	4.84	C-53	3 ins.	1/8 in.	144	3 1/2	4.84
A-36	6 ins.	3/16 in.	144	2 1/4	5.64	C-54	4 ins.	1/8 in.	144	3 3/4	5.64
A-38	8 ins.	3/16 in.	144	2 1/2	6.44	C-55	5 ins.	5/16 in.	144	4	6.44
B-43	3 ins.	1/4 in.	144	2 3/4	4.02	C-56	6 ins.	5/16 in.	144	4 1/4	7.24
B-44	4 ins.	1/4 in.	144	2 5/8	4.84	C-58	8 ins.	5/16 in.	144	4 7/8	8.04
B-45	5 ins.	1/4 in.	144	3 1/8	5.64						

**INSULATED FRICITION DRIVE SCREW DRIVERS**

List No.	Length of Blade	Diameter of Blade	Std. Pkg.	Wt. Lbs. per Doz.	Price per Doz.
E-33	3 ins.	3/8 in.	144	3 1/4	\$8.86
E-36	6 ins.	3/8 in.	144	3 7/8	11.26



Screw-driver Set No. 1

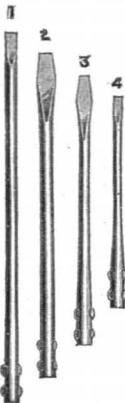

Tool Set No. 4  
**SCREW-DRIVER SET**



Tool Set No. 7

Set No. 1 consists of one friction drive handle with four-jaw screw chuck and four screw-driver blades put up in a box.

List No.	No. of Blades	Std. Pkg.	Wt. Lbs. Std. Pkg.	Retail Price Each	Price per Doz.
S-1	4	12	6 3/4	\$10.80	\$14.48

**AUTO TOOL SETS**

**Tool Set No. 4** consists of one friction drive handle with four-jaw screw chuck, five screw-driver blades and six additional tools.

**Tool Set No. 7** consists of four screw-driver blades, one three-sided angle screw-driver blade No. 5, one gimlet No. 6, one spark plug scraper No. 7, one sharp-pointed awl No. 8, one counter sink No. 9, one taper reamer No. 10, one brad awl No. 11, one friction drive handle or chuck, one double-ended alligator wrench.

S-4	13	12	10	\$27.00	\$36.18
S-7	12	12	10	27.00	36.18

**YANKEE TOOLS**



No. 41 Automatic Drill



No. 44 Automatic Drill

**Automatic Drills**

The No. 41 automatic drill is equipped with eight drill points  $\frac{1}{16}$  to  $\frac{1}{4}$  inch, which are in plain sight when magazine is open. During the return movement of handle the drill point revolves backward to clear chips, etc. Length of tool, inclusive of drill points,  $11\frac{3}{8}$  inches.

The No. 44 automatic drill has spring with adjustable tension. The cap on top of drill has a screw attached to it, by revolving which the spring is made longer or shorter, and as a result weaker or stronger. The spring is held at any desired tension by a small bolt engaging in cap and operated by the small knob on side of handle. The drill has eight drill points,  $\frac{1}{16}$  to  $\frac{1}{4}$  inch, in magazine in handle. Length of tool, inclusive of drill points,  $11\frac{1}{4}$  inches.

List No.	Mfr. No.		*List Price
			Each
760869	41	Automatic drill, complete with 8 drill points.....	\$2.62
760870	44	Automatic drill, complete with 8 drill points.....	2.90

**Ratchet Screw Driver**



No. 12 Ratchet Screw Driver

Adjustment for right or left hand is made by slide moved in direction across length of blade. Made for special use of mechanics requiring a strong, substantial screw driver with short blade. Blade  $\frac{1}{8}$  inch diameter; length over all,  $5\frac{3}{4}$  inches.

List No.	Mfr. No.		*List Price
			Each
760871	12	Ratchet Screw Driver.....	\$0.96

**Yankee Plain Screw Drivers**



No. 90 Standard Style



No. 95 Cabinet Style

Yankee plain screw drivers are strong, durable, well balanced tools of high quality, material and workmanship. The fastenings of blade and handle are such that they cannot be loosened in use, or even the usual abuse. The blades and ferrules are finely polished, the handle of hard wood finished in dull dead black, making a handsome as well as durable appearance. Each screw driver is subjected to a thorough and hard test at factory.

**NO. 90 STANDARD STYLE SCREW DRIVER**

Size, ins.....	4	5	6	8	10	12	15
List No.....	760872	760873	760874	760875	760876	760877	760878
*List, each.....	\$0.36	\$0.42	\$0.50	\$0.68	\$0.86	\$1.02	\$1.38

**NO. 95 CABINET STYLE SCREW DRIVER**

Size, ins.....	3½	5½	6½	7½	8½	10½	12½
List No.....	760879	760880	760881	760882	760883	760884	760885
*List, each.....	\$0.30	\$0.40	\$0.44	\$0.52	\$0.58	\$0.68	\$0.80

\*Delivery F. O. B. Factory, Philadelphia, Pa. For warehouse deliveries write nearest house.

Telephone Apparatus and Supplies

380

## YANKEE RATCHET SCREW DRIVERS



No. 11 Yankee Ratchet Screw Driver

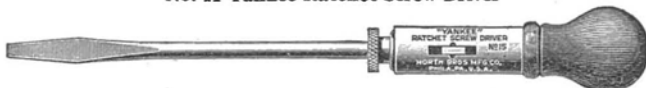

No. 15 Yankee Ratchet Screw Driver

The No. 11 Ratchet Screw Driver is made of the best cast steel, from stock especially imported for that purpose. They are properly tempered, ground and polished, and every single one is tested before leaving factory. Adjustment for right or left hand is made by slide moved in direction across length of blade.

The No. 15 has all of the qualities of the No. 11. Adjustment for right or left hand is made by slide moved in direction of length of blade.

### No. 11 Yankee Ratchet Screw Driver

### No. 15 Yankee Ratchet Screw Driver

List No.	*List Price Each	List No.	*List Price Each	List No.	*List Price Each	List No.	*List Price Each
760886	\$0.76	760888	\$1.12	760890	\$0.60	760892	\$0.70
760887	.98	760889	1.30	760891	.66	760893	.76

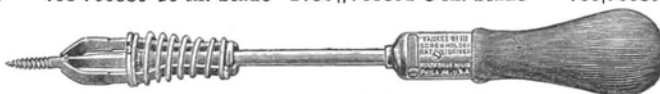

No. 111 Ratchet Screw Driver with Screw Holder Attachment

### No. 111 Ratchet Screw Driver

This screw driver is the same design as the No. 11, but with screw holder attachment. This attachment consists of two jaws, fastened to a head at one end, a ring to limit speed of jaw at other end, and a spring to operate jaws.

List No.	*List Price Each	List No.	*List Price Each
760894	\$1.00	760897	\$1.30
760895	1.08	760898	1.42
760896	1.14		



No. 30 Spiral Ratchet Screw Driver



No. 130 Spiral Ratchet Screw Driver

### Spiral Ratchet Screw Driver

No. 30 drives or draws screws by pushing on handle or by ratchet movement of handle, and can be made rigid as an ordinary screw driver by an ingenious locking device when closed. Three bits of different width are included with each tool.

No. 130 is the same tool as No. 30, with a spring added in handle as shown in illustration which causes the handle to come back for the next push in drawing screws.

List No.	Mfr. No.	Description	*List Price Each
760899	30	Spiral Ratchet Screw Driver	\$2.74
760900	130	Spiral Ratchet Quick Return Screw Driver	3.16



Countersink



Chuck



Bit with Screw Holder



HALF ACTUAL SIZE.  
Drill Points

### ATTACHMENTS FOR SPIRAL SCREW DRIVERS

List No.	Description	*List Price
760901	Chuck with 8 drill points, $\frac{1}{8}$ to $\frac{1}{4}$ in. for Nos. 30 and 130 driver, per doz. sets	\$11.24
760902	Countersink for Nos. 30 and 130 drivers, each	.62
760903	Bit with screw holder attachment, for Nos. 30 and 130 drivers, each	.52

\*Delivery F. O. B. Factory, Philadelphia, Pa. For warehouse deliveries write nearest house.

HAND AND BREAST DRILLS



No. 1530 Hand Drill

“Yankee” Hand Drill

The frame is malleable iron, finished in dead black color. The chuck body is steel, polished and nickel plated. The jaws are of steel, drop forged and hardened. The spindle is of steel and gears are cast iron with cut teeth. Particular attention is called to the little slide on cylinder between gears and the notches. With slide in first notch (at top), it is a plain drill; in second, a left-hand ratchet; in third, a right-hand ratchet; in fourth, a double ratchet, where any movement of crank, forward or backward, causes the drill to cut continuously; in fifth (at bottom), gearing, etc., is locked to open or close chuck.

List No.	Mfr. No.		Weight Lbs.	*List Price Each
760688	1530	Yankee Hand Drill.....	1 1/4	\$4.00

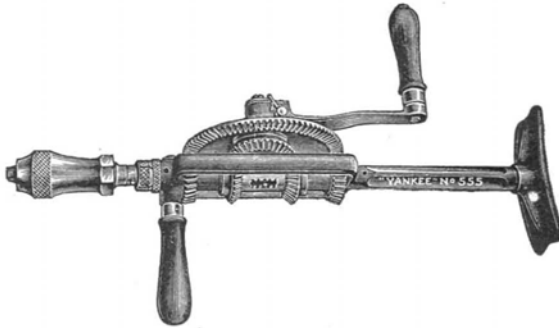

No. 555 Breast Drill

“Yankee” Breast Drill

The frame is malleable iron, the spindle of steel turned and fitted, the gears have the teeth cut from the solid to run smooth and accurately. The tool is finished in a dead black color. Note the little slide on cylinder between gears and notches. With slide in first notch (at top), it is a plain drill; in second, a left-hand ratchet; in third, a right-hand ratchet; in fourth, a double ratchet, where any movement of crank forward or backward causes the drill to cut continuously; in fifth (at bottom), gearing, etc., is locked to open or close chuck.

List No.	Mfr. No.		Weight Lbs.	*List Price Each
760689	555	Breast Drill, double speed, 2 jaw chuck.....	6 1/2	\$8.64

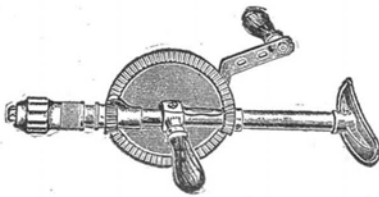

Breast Drill No. 1

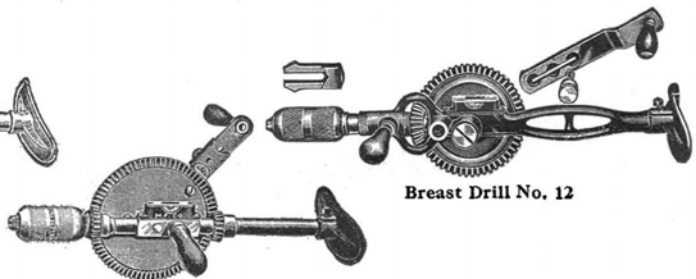

Breast Drill No. 12



Breast Drill No. 13

Breast Drill

List No.	Mfr. No.		Weight Lbs.	†List Price Each
760690	1	Breast Drill, nickel plated, cocobolo handles.....	6	\$6.64
760691	13	Breast Drill, double gear, 6 inch drive wheel.....	6	6.08
760692	12	Breast Drill, ball-bearing changeable gear.....	6 1/2	4.32

\*Delivery F. O. B. Philadelphia, Pa. †Delivery F. O. B. Millers Falls, Mass. For warehouse deliveries write nearest house.

MECHANICS' TOOLS



Corner Bit Brace



Angle Boring Bit Stock

Bit Braces

List No.	Mfr. No.	Description	List Price Each
760584	80	8 inch sweep corner brace.....	\$5.50
760582	100	10 inch sweep corner brace.....	6.00
760583	...	Improved angle boring bit stock.....	2.50



Ratchet Brace

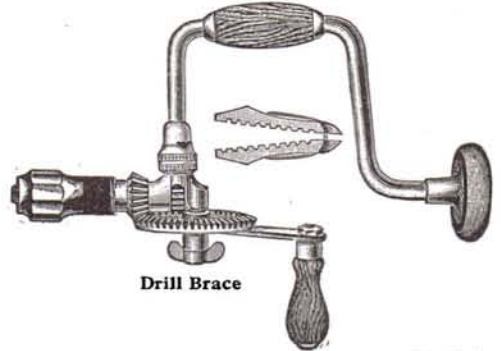

Drill Brace

Bit Braces

List No.	Mfr. No.	Description	List Price Each
760584	62	6 inch sweep ratchet brace.....	\$2.82
760585	82	8 inch sweep ratchet brace.....	2.82
760586	102	10 inch sweep ratchet brace.....	3.02
760587	122	12 inch sweep ratchet brace.....	3.30
760588	142	14 inch sweep ratchet brace.....	3.54
760589	...	Drill brace with 10 inch sweep.....	7.08

Extension Bit Holder



Extension Bit Holder

This extension will follow a 5/8 inch hole. Holds bit absolutely straight.

List No.	Mfr. No.	Description	List Price Each
760590	6120	12 inch length extension bit holder.....	\$2.50
760591	6120	18 inch length extension bit holder.....	2.70
760592	6120	24 inch length extension bit holder.....	2.90

Bell Hanger Wood Drill Bit



Bell Hanger Wood Drill Bit

The numbers indicate the sizes in 32nds of an inch.

12 In.		18 In.		24 In.		30 In.		36 In.	
No.	per Doz.	No.	per Doz.	No.	per Doz.	No.	per Doz.	No.	per Doz.
6	\$6.00	6	\$8.40	6	\$10.80	6	\$13.20	6	\$15.60
8	6.00	8	8.40	8	10.80	8	13.20	8	15.60
10	6.60	10	9.00	10	11.40	10	14.40	10	15.60
12	7.20	12	9.60	12	12.00	12	14.40	12	15.60
14	8.40	14	10.80	14	13.20	14	15.60	14	16.80
16	9.60	16	12.00	16	14.40	16	16.80	16	18.00
18	10.80	18	13.20	18	15.60	18	18.00	18	19.20
20	12.00	20	14.40	20	16.80	20	18.00	20	19.20
22	13.20	22	15.70	22	18.00	22	19.20	22	20.40
24	14.40	24	16.80	24	19.20	24	20.40	24	21.60
26	15.60	26	18.00	26	20.40	26	21.60	26	21.60
28	16.80	28	19.20	28	21.60	28	22.80	28	22.80
30	18.00	30	20.40	30	22.80	30	24.00	30	24.00
32	19.20	32	21.60	32	24.00	32	24.00	32	24.00
34	20.40	34	22.80	34	24.00	34	24.00	34	24.00
36	21.60	36	24.00	36	25.20	36	25.20	36	25.20

**BORING MACHINES**

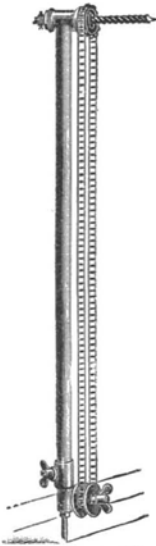

**Henderson Boring Machine**



**Jones Boring Machine**

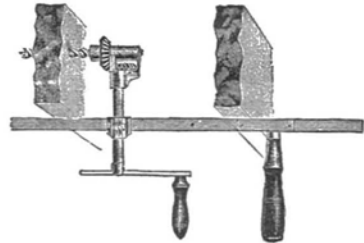

**Anthony Boring Tools**

	<b>HENDERSON BORING MACHINE</b>	†List Price
List No.		Each
760567	For boring joist for electric light wiring. Made of bicycle tubing, nickel plated, with ball bearing shaft, universal bit. Holder extends to 12 feet, and telescopes to 5 feet. . . . .	\$37.50
	<b>JONES CONVERTIBLE BORING MACHINE</b>	†List Price
List No.		Each
760568	This machine is adjustable, and may be used for boring under almost any condition met with in wiring. Has standard bit chuck head. Boring machine, complete. . . . .	\$50.00
	<b>ANTHONY BORING TOOL</b>	†List Price
List No.		Each
760570	Made to take standard 1/2 inch round shank machine bit. But special bits, as listed below, may be furnished, which have a keyway cut in the shank, making it impossible for them to turn in chuck. . . . .	\$12.00



**MACHINE BITS**

**For Anthony Boring Tool**

Size. . . . .	1/4	5/16	3/8	7/16	1/2	9/16	5/8	3/4	7/8	1
List No. . . .	760571	760572	760573	760574	760575	760576	760577	760578	760579	760580
†List Each.	\$0.90	\$0.96	\$1.00	\$1.10	\$1.14	\$1.24	\$1.40	\$1.60	\$1.80	\$2.04

†Delivery F. O. B. Factory, Charlotte, N. C.

†Delivery F. O. B. Factory, Detroit, Mich. For warehouse deliveries write nearest house.

**Telephone Apparatus and Supplies**

## AUGER BITS

### Standard Car and Ship Bits



#### JENNINGS PATTERN

Oil tempered, strictly high grade, full polished, accurate to size.

Size, Inches.....	$\frac{3}{8}$	$\frac{7}{16}$	$\frac{1}{2}$	$\frac{9}{16}$	$\frac{5}{8}$	$\frac{11}{16}$	$\frac{3}{4}$	$\frac{7}{8}$	1	$1\frac{1}{4}$	$1\frac{1}{2}$
List No.....	760611	760612	760613	760614	760615	760616	760617	760618	760619	760620	760621
List per Dozen...	\$2.84	\$3.20	\$3.56	\$3.90	\$4.26	\$5.00	\$5.00	\$5.70	\$6.40	\$8.54	\$10.68



#### IRWIN PATTERN

Solid center, perfect temper, and highly polished. Made accurate to size.

Size, Inches.....	$\frac{3}{8}$	$\frac{7}{16}$	$\frac{1}{2}$	$\frac{9}{16}$	$\frac{5}{8}$	$\frac{11}{16}$	$\frac{3}{4}$	$\frac{7}{8}$	1	$1\frac{1}{4}$	$1\frac{1}{2}$
List No.....	760622	760623	760624	760625	760626	760627	760628	760629	760630	760631	760632
List per Dozen...	\$3.00	\$3.36	\$3.74	\$4.12	\$4.50	\$5.24	\$5.24	\$6.00	\$6.74	\$9.00	\$11.24



#### IRWIN PATTERN CAR BITS

Total length about 18 inches.

Size, Inches.....	$\frac{1}{4}$	$\frac{5}{16}$	$\frac{3}{8}$	$\frac{7}{16}$	$\frac{1}{2}$	$\frac{9}{16}$	$\frac{5}{8}$	$\frac{11}{16}$	$\frac{3}{4}$	$\frac{7}{8}$	1
List No.....	760633	760634	760635	760636	760637	760638	760639	760640	760641	760642	760643
List per Dozen...	\$6.74	\$6.74	\$6.74	\$7.50	\$8.42	\$9.36	\$10.30	\$11.24	\$12.18	\$14.24	\$16.50



#### JENNINGS PATTERN CAR BITS

Total length about 18 inches.

Size, Inches.....	$\frac{1}{4}$	$\frac{5}{16}$	$\frac{3}{8}$	$\frac{7}{16}$	$\frac{1}{2}$	$\frac{9}{16}$	$\frac{5}{8}$	$\frac{11}{16}$	$\frac{3}{4}$	$\frac{7}{8}$	1
List No.....	760644	760645	760646	760647	760648	760649	760650	760651	760652	760653	760654
List per Dozen...	\$8.10	\$8.10	\$8.10	\$9.00	\$10.12	\$11.24	\$12.36	\$13.50	\$14.62	\$17.10	\$19.80



#### SINGLE TWIST CAR BITS

Total length about 18 inches.

Size, Inches.....	$\frac{1}{4}$	$\frac{5}{16}$	$\frac{3}{8}$	$\frac{7}{16}$	$\frac{1}{2}$	$\frac{9}{16}$	$\frac{5}{8}$	$\frac{11}{16}$	$\frac{3}{4}$	$\frac{7}{8}$	1
List No.....	760655	760656	760657	760658	760659	760660	760661	760662	760663	760664	760665
List per Dozen...	\$9.00	\$9.00	\$9.00	\$10.00	\$11.24	\$12.50	\$13.74	\$15.00	\$16.24	\$19.00	\$22.00



#### SHIP AUGER CAR BITS

12 inch twist.

Size, Inches.....	$\frac{1}{4}$	$\frac{3}{8}$	$\frac{7}{16}$	$\frac{1}{2}$	$\frac{9}{16}$	$\frac{5}{8}$	$\frac{11}{16}$	$\frac{3}{4}$	$\frac{13}{16}$	$\frac{7}{8}$	1
List No.....	760666	760667	760668	760669	760670	760671	760672	760673	760674	760675	760676
List per Dozen...	\$9.56	\$10.12	\$10.68	\$11.24	\$11.80	\$12.36	\$12.92	\$13.50	\$14.06	\$14.62	\$16.30



#### SINGLE TWIST AUGER BITS

Size, Inches.....	$\frac{3}{8}$	$\frac{7}{16}$	$\frac{1}{2}$	$\frac{9}{16}$	$\frac{5}{8}$	$\frac{11}{16}$	$\frac{3}{4}$	$\frac{7}{8}$	1	$1\frac{1}{4}$	$1\frac{1}{2}$
List No.....	760677	760678	760679	760680	760681	760682	760683	760684	760685	760686	760687
List per Dozen...	\$4.00	\$4.50	\$5.00	\$5.50	\$6.00	\$7.00	\$7.00	\$8.00	\$9.00	\$12.00	\$15.00

## MECHANICS' TOOLS Clark Expansion Bits

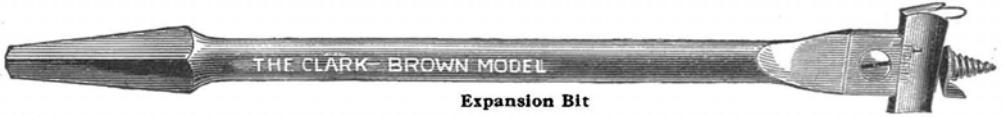

Expansion Bit

<b>List No.</b>		<b>List Price Each</b>
760594	With 2 cutters, one boring from $\frac{1}{2}$ to $\frac{3}{8}$ , and the other from $\frac{7}{8}$ to $1\frac{1}{2}$ inches.....	\$1.50
760595	With 2 cutters, one boring from $\frac{7}{8}$ to $1\frac{3}{4}$ , and the other from $1\frac{3}{4}$ to 3 inches.....	2.25



No. 75 Yankee Push Brace

### Yankee Push Brace

Is made to hold all the small tools used in a bit brace, but is operated by pushing the handle to revolve the tools in same manner as a spiral ratchet screw driver. It will with little effort bore  $\frac{1}{8}$  inch holes in metal, drive  $\frac{3}{8}$  inch auger bit in hard wood, or  $\frac{1}{2}$  inch to  $\frac{5}{8}$  inch bits in white pine. It can be used for tapping holes, and with socket wrench drive in small lag screws, run burrs or nuts on bolts, also used with screw driver bit, etc. Being straight and cylindrical and operated by pushing, it can reach into many places in corners, holes back of obstructions, where a brace can not be operated. The spiral rod is of steel, grooved for both right and left hand with extra long nuts of hard bronze, to secure extra durability. The chuck is made of malleable iron, polished and nickel plated. The jaws are of steel, drop forged and hardened. The chuck will hold squares up to  $\frac{1}{2}$  inch wood bit. The handle is  $2\frac{3}{8}$  inches in diameter, of hard wood, polished. The entire length of tool, without bit, when closed, is  $16\frac{1}{4}$  inches; when extended,  $23\frac{1}{2}$  inches.

<b>List No.</b>	<b>Mfr. No.</b>		<b>†List Price Each</b>
760593	75	Yankee Push Brace.....	\$4.74

### Standard Wrenches



Stillson Wrench

#### STILLSON WRENCHES

List No.	Length Inches	Grips Pipe	Wire	List Price Each
760596	6	$\frac{1}{2}$	$\frac{3}{8}$	\$1.00
760597	8	$\frac{3}{4}$	$\frac{1}{8}$	1.00
760598	10	1	$\frac{1}{8}$	1.14
760599	14	$1\frac{1}{2}$	$\frac{1}{4}$	1.50
760600	18	2	$\frac{1}{4}$	2.00
760601	24	$2\frac{1}{2}$	$\frac{1}{4}$	3.00
760602	36	$3\frac{1}{2}$	..	6.00
760603	48	5	..	9.00



Monkey Wrench

#### MONKEY WRENCHES

List No.	Description	List Price Each
760604	6 inch monkey wrench.....	\$0.90
760605	8 inch monkey wrench.....	1.00
760606	10 inch monkey wrench.....	1.20
760607	12 inch monkey wrench.....	1.40
760608	15 inch monkey wrench.....	2.40
760609	18 inch monkey wrench.....	3.00
760610	21 inch monkey wrench.....	3.60

### Cochran Pipe Wrench

Mfr. No.	List No. (Complete)	Size	Range	Price	\$761326	\$761327	\$761328	\$761329
1	Hook Jaws.....	6 ins.	$\frac{1}{8}$ to $\frac{1}{2}$	each.	\$2.00†	\$2.00†	\$2.26†	\$3.00†
2	Inserted.....	8 ins.	$\frac{1}{4}$ to $\frac{3}{4}$	each.	.68	.68	.76	1.00
3	Rockers.....	10 ins.	$\frac{1}{8}$ to 1	each.	.26	.26	.28	.40
4	Nuts.....	14 ins.	$\frac{1}{2}$ to 1	each.	.20	.20	.28	.36
5	Springs.....	18 ins.	$\frac{1}{4}$ to $1\frac{1}{2}$	each.	.12	.12	.14	.18
	Weight of wrench.....	6 ins.	8 ins.	10 ins.	14 ins.	1/2 lb.	3/4 lb.	1 1/2 lbs.
	Number packed in a box.....	8 ins.	10 ins.	14 ins.	18 ins.	1/2 doz.	1/2 doz.	1/2 doz.
	Weight of box and contents.....	10 ins.	14 ins.	18 ins.	21 ins.	3 lbs.	5 lbs.	10 lbs.

†Delivery F. O. B. Factory, Philadelphia, Pa. ‡Delivery F. O. B. Factory, Chicago, Ill. For warehouse deliveries write nearest house.

REAMERS AND HAMMERS



Lightning Burring Reamer

Lightning Taper Reamer No. 460

Lightning Burring Reamer

Is made of fine steel, carefully ground to cut iron, brass, wood, etc. Used for pipe, also for counter-sinking.

List No.	Mfr. No.	Diam. at Point Inches	Length of Flute Inches	Burring Pipe Sizes Inches	List Price Each	List No.	Mfr. No.	Diam. at Point Inches	Length of Flute Inches	Burring Pipe Sizes Inches	List Price Each
760729	542	$\frac{7}{32}$	1	$\frac{1}{8}$ to $\frac{1}{2}$	\$1.34	761289	554	$\frac{5}{16}$	$2\frac{3}{16}$	$\frac{1}{4}$ to $1\frac{1}{4}$	\$2.00
760730	544	$\frac{7}{16}$	$1\frac{9}{16}$	$\frac{3}{8}$ to 1	1.68	761290	546	$\frac{15}{16}$	$2\frac{1}{2}$	1 to 2	4.00

Lightning Taper Reamers

List No.	Diameter	Length of Flute Inches	Total Length Inches	List Price Each	List No.	Diameter	Length of Flute Inches	Total Length Inches	List Price Each
760731	$\frac{3}{8}$	$2\frac{3}{16}$	$4\frac{9}{16}$	\$0.74	760737	$\frac{3}{4}$	$2\frac{7}{8}$	$6\frac{7}{16}$	\$1.60
760732	$\frac{7}{16}$	$2\frac{3}{8}$	$4\frac{11}{16}$	.80	760738	$\frac{13}{16}$	$3\frac{1}{8}$	$6\frac{7}{16}$	1.88
760733	$\frac{1}{2}$	$2\frac{1}{2}$	$5\frac{1}{16}$	.94	760739	$\frac{7}{8}$	$3\frac{1}{2}$	$6\frac{11}{16}$	2.14
760734	$\frac{9}{16}$	$2\frac{3}{4}$	$5\frac{15}{16}$	1.07	760740	$\frac{15}{16}$	$3\frac{3}{8}$	7	2.40
760735	$\frac{5}{8}$	$2\frac{3}{4}$	$5\frac{15}{16}$	1.20	760741	1	$3\frac{3}{8}$	7	2.68
760736	$\frac{11}{16}$	$2\frac{7}{8}$	$6\frac{1}{16}$	1.42	760742	$1\frac{1}{8}$	$3\frac{5}{8}$	$7\frac{1}{4}$	3.20



Plain Face



Bell Face



Machinist's Ball Pein

ADZE EYE NAIL HAMMERS Plain and Bell Face

List No.	Size	Weight Ozs.	List Price Each	List No.	Size	Weight Ozs.	List Price Each
760743	0	28	\$1.04	760745	$1\frac{1}{2}$	16	\$0.70
760744	1	20	.74	760746	2	13	.64

MACHINISTS' BALL PEIN

List No.	Size	Weight Ozs.	List Price Each	List No.	Size	Weight Ozs.	List Price Each
760747	000	8	\$1.00	760749	2	24	\$1.24
760748	0	16	1.04	760750	4	32	1.40



Striking Hammer

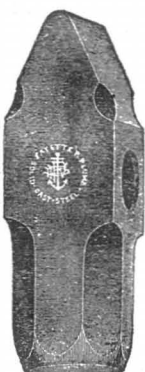

Sledge Hammer

Drilling or Striking Hammers

Nevada Pattern

List No.	Mfr. No.	Weight	List Price per Lb.
760751	860	Polished faces, oil finished, under 3 lbs.	\$0.50
760752	860	Polished faces, oil finished, 3 to 5 lbs.	.40
760753	860	Polished faces, oil finished, 5 lbs. and above	.30

Sledge Hammers

List No.	Mfr. No.	Weight	List Price per Lb.
760754	1030	under 3 lbs.	\$0.50
760755	1030	3 to 5 lbs.	.40
760756	1030	5 lbs and above	.30

SAWS



Disston Hand Saws

Crucible steel, patent ground and tempered, grained blade, beech handle.

List No.		†List Price Each	List No.		†List Price Each
760757	16 in. panel saw.....	\$1.60	760760	22 in. panel saw.....	\$2.26
760758	18 in. panel saw.....	1.74	760761	24 in. panel saw.....	2.36
760759	20 in. panel saw.....	1.98	760762	26 in. hand saw.....	2.48

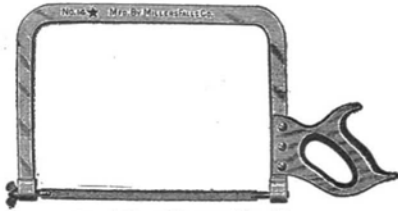

Hack Saw Frame No. 14



Hack Saw Frame No. 15

Hack Saw Frames

List No.	Mfr. No.		†List Price Each	List No.	Mfr. No.		†List Price Each
760763	14	12 in. inside frame to tooth edge.....	\$3.00	760764	15	Polished and nicked... Depth, 5¼ inches for 12 inch blade..	\$2.40



Hack Saw Frame No. 26

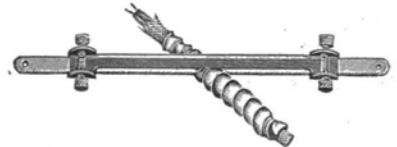

Hack Saw Depth Gauge No. 53

HACK SAW FRAME NO. 110

List No.	Mfr. No.		†List Price Each
760765	26	Steel frame, nicked, riveted sockets, reversible hack saw frame.....	\$1.08

Hack Saw Blades

FOR HAND USE

Length, inches.....	6	7	8	9	10	11	12	17	18
List, per gross.....	\$6.14	\$6.68	\$7.08	\$8.00	\$8.80	\$9.74	\$10.54	\$19.98	\$19.98

FOR POWER USE

Size	List Price per Gross	Size	List Price per Gross
12 x 5/8 x .032 in.....	\$14.14	14 x 3/4 x .049 in.....	\$34.58
12 x 3/4 x .032 in.....	21.60	14 x 1 x .049 in.....	45.74
12 x 3/4 x .049 in.....	29.62	17 x 1 x .049 in.....	55.54
12 x 1 x .049 in.....	39.20	17 x 1 x .065 in.....	64.26
14 x 1/2 x .030 in.....	15.92	24 x 1 x .049 in.....	74.48
14 x 3/4 x .032 in.....	25.20	24 x 1 x .065 in.....	90.72

Hack Saw Depth Gauge No. 53

List No.	Mfr. No.		List Price Each
761713	53	Pressed steel length 7½.....	\$0.50

†Delivery F. O. B. Factory, Philadelphia, Pa. \*Delivery F. O. B. Factory, Boston, Mass. For warehouse deliveries write nearest house.

## STEEL DRILLS

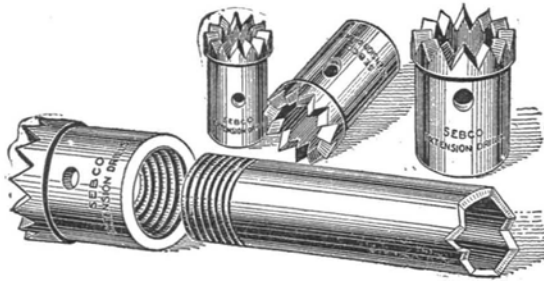

Extension Drills

### SebcO Extension Drills FOR BRICK AND STONE

These drill heads are designed with the view of increasing efficiency and decreasing cost of time and energy. The quicker, neater, and easier a job is done the more satisfactory and cheaper is the cost of the work. For drilling deep holes in brick and plaster they are very convenient to use. The heads are made of best steel, carefully tempered. A piece of gas or water pipe may be used as a handle, making it any length desired. One piece of gas pipe will fit six different sizes of drill heads. When the job is completed, unscrew the head and throw the handle aside. SebcO drills never break nor crumble brick; they drill a hole clean and smooth and do not bind.

List No.	Diameter of Cutting Edge	Size Pipe For Handle	*List Price per Doz.	List No.	Diameter of Cutting Edge	Size Pipe For Handle	*List Price per Doz.
761299	5/8 in.	1/8 in.	\$3.84	761308	2 ins.	1 in.	\$20.00
761300	3/4 in.	1/4 in.	3.84	761309	2 1/4 ins.	1 in.	30.00
761301	7/8 in.	3/8 in.	3.84	761310	2 1/2 ins.	1 in.	36.66
761302	1 in.	1/2 in.	3.84	761311	2 3/4 ins.	1 in.	45.00
761303	1 1/8 ins.	1/2 in.	6.00	761312	3 ins.	1 in.	51.66
761304	1 1/4 ins.	3/4 in.	7.00	761313	3 1/4 ins.	1 1/4 ins.	60.00
761305	1 3/8 ins.	3/4 in.	12.50	761314	3 1/2 ins.	1 1/4 ins.	66.66
761306	1 1/2 ins.	3/4 in.	15.00	761315	3 3/4 ins.	1 1/4 ins.	73.32
761307	1 3/4 ins.	1 in.	17.50	761316	4 ins.	1 1/4 ins.	80.00

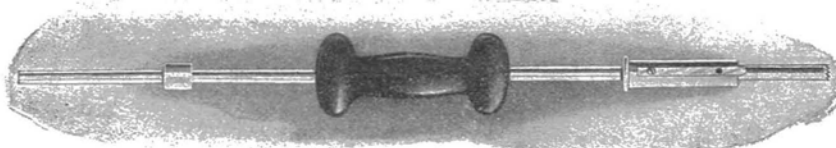

Hammer Drill



1/2 x 4" Drill Point



3/8 x 6" Drill Point

### Peirce Hammer Drill

This tool offers the one quick means of drilling holes easily in brick, stone and concrete. It takes various sizes of drill points, which are quickly removed for sharpening. The guard on chuck has been enlarged to better protect the hand. The collar is welded to rod instead of being brazed. The dumb-bell is made of malleable iron.

List No.	Description	†List Price Each	List No.	Description	†List Price Each
760829	Hammer drill, only for 1/4 in. bolts.	\$8.16	760832	5/8 x 6 in. drill point, for 3/8 in. bolts.	\$1.62
760830	Hammer drill, only for 3/8 in. bolts.	8.68	760833	5/8 x 12 in. drill point	2.06
761317	3/4 x 4 in. drill point.	1.10	760834	3/4 x 6 in. drill point	1.92
760831	1/2 x 4 in. drill point, for 1/4 in. bolts.	1.10	760835	3/4 x 12 in. drill point	2.30
761318	1/2 x 6 in. drill point	1.24	760836	7/8 x 6 in. drill point, for 1/2 in. bolts	2.06
761319	1/2 x 12 in. drill point	1.36	760837	7/8 x 12 in. drill point	2.46

\*Delivery F. O. B. Factory, Bayonne, N. J. †Delivery F. O. B. Factory, Pittsburgh, Pa. For warehouse deliveries write nearest house.

## STEEL DRILLS

For Brick and Stone



### Sebco Steel Drills

Is especially adapted for drilling brick and stone.

List No.	Length	Diameter of Cutting Edge										
		1/4	5/16	3/8	7/16	1/2	5/8	3/4	7/8	1	1 1/8	1 1/4
760838	12	\$8.50	\$8.50	\$8.50	\$9.00	\$10.00	\$12.00	\$14.00	\$16.00	\$18.00	\$24.00	\$30.00
760839	18	11.00	11.00	11.00	11.50	12.50	15.00	17.50	20.00	22.50	28.00	35.00
760840	24	13.50	13.50	13.50	14.00	15.00	17.50	20.00	22.50	25.00	32.00	40.00

Specify diameter of cutting edge in ordering.



### Star Pipe Drills

This drill is unequalled for a clean, quick job; is best for brick, concrete, etc.

List No.	Length	Diameter of Cutting Edge										
		1/4	5/16	3/8	7/16	1/2	5/8	3/4	7/8	1	1 1/8	1 1/4
760841	12	\$8.50	\$8.50	\$8.50	\$9.00	\$10.00	\$12.00	\$14.00	\$16.00	\$18.00	\$24.00	\$30.00
760842	18	11.00	11.00	11.00	11.50	12.50	15.00	17.50	20.00	22.50	28.00	35.00
760843	24	13.50	13.50	13.50	14.00	15.00	17.50	20.00	22.50	25.00	32.00	40.00

NOTE: Price of drills of intermediate diameter, same as next size larger. At proportionate list prices, drills of larger diameter or greater lengths will be furnished promptly on order. Specify diameter of cutting edge in ordering.

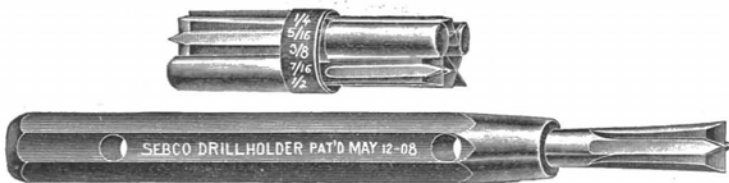

### Improved Star Drill Set

Is made of the best tool steel, and is preferred by up-to-date workmen because of its durability. A set comprises any assorted six steel drill points and one holder, neatly packed in a wooden box. The drills wear a long time before redressing is needed. They will drill 2 1/2 inches to 3 1/2 inches in depth.

List No.	Special Star Drill Points										
	1/4	5/16	3/8	7/16	1/2	5/8	3/4	7/8	1	1 1/8	1 1/4
760844	\$7.64	\$7.64	\$7.64	\$7.64	\$7.64	\$8.10	\$8.10	\$8.10	\$9.00	\$10.80	\$12.60

Specify size in ordering.

List No.	Drill Holder	List Price per Doz.
760845	Drill Holder (fits all drills)	\$15.00

\*Delivery F. O. B. Factory, Bayonne, N. J. For warehouse deliveries write nearest house.

Telephone Apparatus and Supplies

## MEASURING TAPES



Enameled Steel Case



Star Steel Tape

### Cotton Tape

#### Enameled Steel Case with Brass Trimmings

These tapes are half inch in width, enclosed in an enameled steel case, brass bound. They are the cheapest tape made, and are only adapted to the most ordinary work; although printed from a standard, they are liable to variations in use.

List No.	Mfr. No.		List Price per Doz.
760904	30	25 feet $\frac{1}{2}$ inch cotton ass' skin	\$5.90
760905	33	50 feet $\frac{1}{2}$ inch cotton ass' skin	7.86
760906	35	75 feet $\frac{1}{2}$ inch cotton ass' skin	11.80
760907	37	100 feet $\frac{1}{2}$ inch cotton ass' skin	14.16

### Star Steel Tape

This tape is  $\frac{3}{8}$  inch wide and the case is made of steel, nickel plated, and fitted with flush handle. It is one of the most popular tapes on the market for the reason that it is strongly made, winds easily, is compact in form, and although cheap is very durable.

List No.	Mfr. No.		List Price Each
760908	497	25 feet $\frac{3}{8}$ inch steel tape	\$4.44
760909	500	50 feet $\frac{3}{8}$ inch steel tape	5.34
760910	502	75 feet $\frac{3}{8}$ inch steel tape	7.12
760911	503	100 feet $\frac{3}{8}$ inch steel tape	9.50

Steel tape lines will be coppered or nickel plated to prevent rusting when so ordered, at an advance in price.



Metallic Warp Tape

### Metallic Warp Tape

This tape is  $\frac{5}{8}$  inch in width, and contains metal threads to prevent stretching. Nicely finished and reinforced on the first end with leather to prevent breaking, and is as near waterproof as possible. The cases are of heavy russet leather, fitted with flush handles, and all metal work is nickel plated.

List No.	Mfr. No.		List Price per Doz.
760912	137	25 feet $\frac{5}{8}$ inch metallic warp tape	\$34.90
760913	140	50 feet $\frac{5}{8}$ inch metallic warp tape	49.86
760914	142	75 feet $\frac{5}{8}$ inch metallic warp tape	69.82
760915	143	100 feet $\frac{5}{8}$ inch metallic warp tape	79.80

MEASURING TOOLS

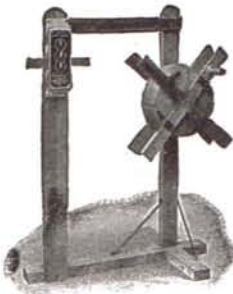

Wire Measuring Machine



Wire Meter



High Speed Indicator

Reels and Meters

A most efficient device for measuring and reeling wire and cordage of various sizes.

List No.	Description	*List Price Each	List No.	Description	*List Price Each
761000	Wire meter with reel.....	\$50.00	761002	Counter meter.....	\$32.90
761001	Meter only.....	32.00	761003	Cable meter only.....	50.00

High Speed Indicator

This indicator may be run at highest speed required without heating, and this on account of the frictionless bearing against which the inner end of the spindle revolves. The dial plate has two rows of figures, reading right or left, as the shaft may run.

List No.	Mfr. No.	Description	†List Price Each
761004	104	Complete with rubber tips.....	\$1.88
761005	106	Improved indicator, same as 104, with rubber handle and tips complete.....	3.76
761006	109	Surface speed attachments for speed indicators.....	.94
761007	109-A	Leather case for speed indicator.....	.94



B&S Wire Gauge

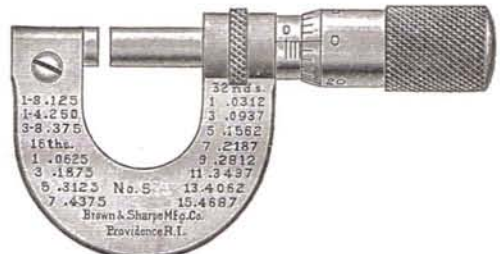

Micrometer Caliper

Wire Gauge

These gauges are manufactured from the best steel, and are tempered, adjusted, and warranted accurate. Size 3¼ inches in diameter and ⅛ inch thick. In order to be familiar with the usage of these gauges with the decimal equivalents of the gauge numbers, we furnish both sizes with these decimal equivalents expressed in thousandths on the back, opposite to the regular gauge numbers.

List No.	Mfr. No.	Description	†List Price Each
761008	688	Size wire B&S gauge, 0 to 36, American standard.....	\$4.26
761334	688	Size wire B&S gauge, 5 to 36, American standard.....	3.40
761335	690	Size wire BWG gauge, 1 to 36, English standard.....	3.40
761009	690	Size wire BWG gauge, 6 to 36, English standard.....	3.40

Micrometer Caliper No. 2

English or Metric Measure

Measures all sizes less than one-half inch by one-thousandths of an inch. It is also made to measure all sizes less than 13 millimeters by hundredths of a millimeter. When so made the table of decimal equivalents is omitted.

List No.	Description	List Price Each
761010	2 Range 0 to ½ inch, or 0 to 13 mm.....	\$8.50
761011	.. Same, with ratchet stop.....	9.36
761012	.. Morocco case.....	1.12

\* Delivery F. O. B. Factory, Minneapolis, Minn. † Delivery F. O. B. Factory, Athol, Mass. ‡ Delivery F. O. B. Factory, Providence, R. I. For warehouse deliveries write nearest house.

## ELECTRIC SOLDERING IRONS

All soldering irons are furnished complete, finished in polished nickel, with six foot cords but no attachment plugs. Elements are removable and extra elements can be furnished complete with core.



No. 3108



No. 3111



No. 3110

### No. 3108 SOLDERING IRON

This is a light telephone iron adapted for switchboard work. Tips can be furnished that will extend several inches beyond the end of the iron. Can be bent to any angle desired.

List No.	Diam. of Tips	Watts	Length	Shape Tips	Wt.	Shpg. Wt.	List Price Each
†3108	$\frac{5}{16}$ ins.	100	11 ins.	A	10 oz.	1 $\frac{1}{4}$ lbs.	\$8.40

### No. 3110 SOLDERING IRON

This is for small light work only, such as soldering together small brass parts, connections, etc.

3110	$\frac{7}{8}$ ins.	100	12 ins.	C or D	1 lb.	1 $\frac{1}{2}$ lbs.	\$8.40
------	--------------------	-----	---------	--------	-------	----------------------	--------

### No. 3111 SOLDERING IRON

This is a standard telephone iron used for switchboard and also by manufacturers upon small parts. It is the most popular iron for this class of work.

3111	$\frac{7}{16}$ in.	100	13 ins.	A	1 lb.	1 $\frac{1}{2}$ lbs.	\$8.40
------	--------------------	-----	---------	---	-------	----------------------	--------

Always specify voltage when ordering.



No. 3120



No. 3130



No. 3121

### No. 3120 SOLDERING IRON

It is for all around light work. Used by electric wiremen, lead glaziers, etc.

List No.	Diam. of Tips	Watts	Length	Shape Tips	Wt.	Shpg. Wt.	List Price Each
3120	1 in.	150	12 ins.	C or D	1 $\frac{1}{2}$ lbs.	2 lbs.	\$9.10

### No. 3121 SOLDERING IRON

This is for light constant work where a slightly hotter and heavier iron than the No. 3111 is required.

3121	$\frac{1}{2}$ in.	130	13 ins.	B	1 $\frac{3}{8}$ lbs.	1 $\frac{3}{4}$ lbs.	\$9.10
------	-------------------	-----	---------	---	----------------------	----------------------	--------

### No. 3130 SOLDERING IRON

This is a very satisfactory iron for all around work, heavy enough to do any ordinary soldering, and still not too heavy for the lighter work.

†3130	1 $\frac{1}{4}$ ins.	300	14 ins.	C or D	2 $\frac{1}{2}$ lbs.	2 $\frac{3}{4}$ lbs.	\$10.50
-------	----------------------	-----	---------	--------	----------------------	----------------------	---------

Always specify voltage when ordering.

Made in following voltage ranges: 95-104, 105-114, 115-125, 190-209, 210-229, 230-250. Furnished with six-foot cord directly attached.

†These devices can be secured for 30 and 60 volt circuits at no extra charge.

**SOLDERING COPPERS**



**Pony Soldering Coppers**

Fitted with Black Lacquered Handles

Specially adapted for electrical work. Made of pure copper, tinned.

List No.	Mfr. No.	Size	Length of Handle,		List Price Each	List No.	Mfr. No.	Size	Length of Handle,		List Price Each
			Inches	Weight					Inches	Weight	
760919	51	No. 1 copper..	12 1/2	5 1/2 oz.	\$1.20	760922	54	No. 4 copper..	8 3/4	1 oz.	\$0.60
760920	52	No. 2 copper..	11 1/2	3 oz.	1.00	760923	55	No. 5 copper..	8 3/4	1/8 oz.	.40
760921	53	No. 3 copper..	9 1/2	1 3/4 oz.	.80						

**SOLDERING ACCESSORIES**



Soldering Furnace



Melting Pot

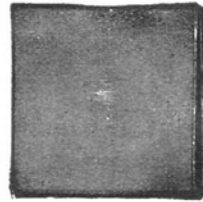

Wiping Cloth



Pouring Ladle

**Charcoal Soldering Furnace, Galvanized Iron**

For melting solder and heating soldering irons. Opening in top admits 6 inch melting pot. Furnace is provided with grate.

List No.	Description	Weight	List Price Each
3550-6	With removable cast iron top .....	12 lbs.	\$8.00

**Melting Pots**

List No.	Description	List Price Each	List No.	Description	List Price Each
761124	5 in. cast iron pot.....	\$0.80	761126	8 in. cast iron pot.....	\$1.50
761125	6 in. cast iron pot.....	1.00			

**Wiping Cloths**

For Wiping Lead Joints, Etc.

761127	Moleskin.....	\$0.50	761128	Ticking.....	\$0.30
--------	---------------	--------	--------	--------------	--------

**Double Lip Pouring Ladles**

761129	2 1/2 in. bowl.....	\$0.50	761131	4 in. bowl.....	\$0.80
761130	3 in. bowl.....	.60	761132	5 in. bowl.....	1.00

FIRE POTS AND TORCHES

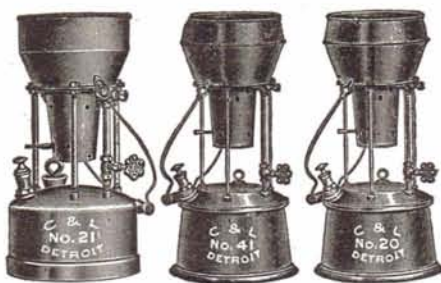

No. 21 Fire Pot No. 41 Fire Pot No. 20 Fire Pot

Nos. 20 and 10 Fire Pots for Gasoline

List No.	Capacity	Weight	List Price
		Lbs.	Each
20	One gallon with automatic pump.....	13 lbs.	Special
10	One gallon with rubber bulb.....	13 lbs.	Special

Fitted with galvanized cast iron top plate and bottom ring. All small or light castings are malleable iron or brass. The coil and burner are steel. The needle point valves are fitted with stuffing boxes and are always tight and give perfect control of the fire.

Nos. 21 and 11 Fire Pots for Gasoline

21	One gallon with automatic pump.....	9¾ lbs.	Special
11	One gallon with rubber bulb.....	9¾ lbs.	Special

The latest improved up-to-date coil fire pot made, with seamless drawn steel tank, large funnel and filler plug, heavy uprights, large valve, heavy malleable top plate and one-piece steel shield.



No. 106 Torch

No. 110 Torch

Nos. 41 and 31 Fire Pots for Gasoline

List No.	Capacity	Weight	List Price
		Lbs.	Each
41	One gallon with automatic pump.....	13 lbs.	Special
31	One gallon with rubber bulb.....	13 lbs.	Special

Coil fire pot with malleable iron small fittings throughout, cast top plate and bottom ring.

No. 106 Torch for Gasoline (Pint Size)

106 With detachable soldering copper holder.. 3¾ lbs. Special

A high-grade torch that will give good satisfaction. The burner is made of generator metal, producing a steady blue flame of intense heat and will work well indoors or outside. It is fitted with automatic brass pump with double spring check valve which easily and quickly supplies all needed air pressure.

No. 110 Torch for Gasoline (Pint Size)

110 With detachable soldering copper holder.. 3¾ lbs. Special

The No. 110 is similar to No. 106 with the exception of pump, which is in the tank, and metal wheel on needle.



No. 108 Torch

No. 107 Torch

Nos. 108 & 107 Gasoline Torches (Qt. Size)

108 With hook and support for soldering copper 5¼ lbs. Special

107 Without hook and support for soldering copper 5 lbs. Special

This meets the demand for a cheaper quart torch. It has a good burner mounted in the center of the tank, and while it will not produce as much heat as the better grade torches, it is well worth the price and will give satisfaction.

No. 10 Torch for Alcohol

10 Torch. Size, 1¾ x 6 inches..... 1 lb. Special

The No. 10 is a blow-pipe torch. Air blast produces a hot blue flame. Evaporation of fuel prevented by screw-cap over wick. Air blast tube is adjustable. Nickeled.

No. 14 Torch for Alcohol or Gasoline

14 Torch. Size, 1¾ x 6½ inches..... 1 lb. Special

The No. 14 burns alcohol or gasoline. Air blast through full chambers makes hotter flame than other methods. Nickeled.

No. 28 Torch for Alcohol

28 Torch. Size 1¾ x 7¼ inches..... 1 lb. Special

A torch or blow pipe for electricians for producing a fine concentrated flame. Finish brass, nickeled.



No. 10

No. 28 Alcohol Torches

No. 14

Trundy Soldering Iron Furnace

Made of wrought iron, with a false bottom, which makes danger or damage from downward heat impossible. 15 inches long, 9 inches high, and 7¼ inches wide. Designed to be packed in the tool chest along with other tools.

760976 Trundy Furnace, New York and Chicago style..... 19 \$16.90

\*Delivery F. O. B. Factory, Chicago, Ill. †Delivery F. O. B. Factory, New York City. For warehouse deliveries, write nearest house.

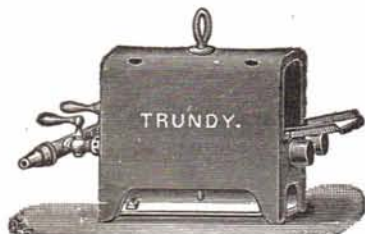

Trundy Soldering Furnace

CABLE TOOLS



Oval



Triangle

Plumber's Scrapers

For scraping lead sleeves, lead pipe, lead-covered cable ends of potheads, etc.

List No.		List Price Each
760989	Oval head lead scraper .....	\$0.60
760990	Triangle-shaped lead scraper .....	.60



No. 1515-1



No. 1515-2

Cable Splitting Knives

List No.		Weight per Doz.	List Price Each
1515-1	Cable splitting knife, with leather handle .....	6 $\frac{3}{8}$ lbs.	\$2.00
1515-2	Cable splitting knife, solid steel, polished .....	5 $\frac{1}{2}$ lbs.	1.50



Cable Stripper Knife No. 1560-1



Cableman's Saw

Cable Stripper and Cable Saw

List No.	Cable Stripper Knife	Weight per Doz.	List Price Each
1560-1	Cable stripper knife, polished .....	3 $\frac{1}{2}$ lbs.	\$2.30

Klein's Cableman's Saw

This saw is particularly recommended for use on cable work. One side has coarse teeth for cutting through lead cable sheath, while the other has finer teeth for cutting through the wire core. The saw is made of silver steel, with apple handle fastened by three brass screws passing through the blade and into brass flush nuts on the other side. Length of blade, 14 inches. Length over all, 18 inches.

906-14	Double-edged cableman's saw .....	Weight Each $\frac{7}{8}$ lb.	\$2.00
--------	-----------------------------------	-------------------------------	--------

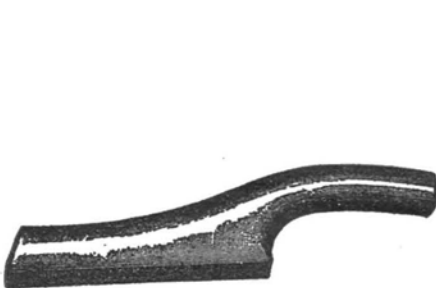

Boxwood Dresser



Boxwood Turning Pin



Boxwood Bossing Stick

Shaping Tools

List No.		List Price Each
760995	Boxwood dresser for shaping lead sleeves, lead pipe, etc. ....	\$1.80
760996	Boxwood bossing stick, for shaping lead sleeves, lead pipe, etc. ....	1.80
760997	Boxwood turn pin, size 1 .....	.50
760998	Boxwood turn pin, size 2 .....	.50
760999	Boxwood turn pin, size 3 .....	.50

NOTE: Boxwood turn pins are for expanding ends of lead pipe, lead sleeves, potheads, etc.

# Western Electric

## SMALL ELECTRIC LIGHT OUTFITS

### General

Why not light your home with electricity?

It is superior to all other light, is safe, healthy, costs little and can be used anywhere. Unlike the other forms of lighting, the electric light bulb has no flame and gives off but very little heat. It can be used and left burning near hay, grain, cotton or paper without danger of fire. On the other hand, you have read or heard of the oil lantern being kicked over in the milking stall, or hay loft; of children overturning the kerosene table lamp; of gas explosions, leaky pipes, and the thousands of fires from matches.

Then, too, electric light is healthier. Any flame, either of gas or kerosene oil, robs the air in a room of its oxygen, and so makes it unhealthy to breathe. The electric light uses no oxygen and gives off no gas. It leaves the air pure.

With electric light you can enjoy many conveniences of electric power.

You can clean thoroughly and quickly with a vacuum cleaner, wash your dishes or your clothes with an electric machine, cook, iron, churn, separate milk, cut fodder, pump water, charge an electric automobile ventilate and cool the house, operate an incubator and a brooder and do many other useful things with simple and reliable appliances that we can supply.



Electric Light Saves Your Eyesight



It's a Flameless, Smokeless and Safe Light

You need a light that is all light, not mixed with heat, flame, smoke and smell. A light that is always ready upon the touch of a button. You need the electric light for every reason you can think of, you need electric power and you do not have it—why? Because you live beyond the reach of the electric light company's wires.

Wherever your home is, you can enjoy the modern electrical comforts. Whether it is your regular home, your summer bungalow or your farm, you can have electric light and power from the simplest, most efficient, and economical outfit on the market, the Western Electric Small Electric Light Plant.

You can secure one of these inexpensive and easy-to-run little outfits, tuck it away in a corner, an out-building or the cellar, and enjoy all the comforts of "push-the-button" light. The outfit is easily operated and costs little to run.

## SMALL ELECTRIC LIGHT OUTFITS

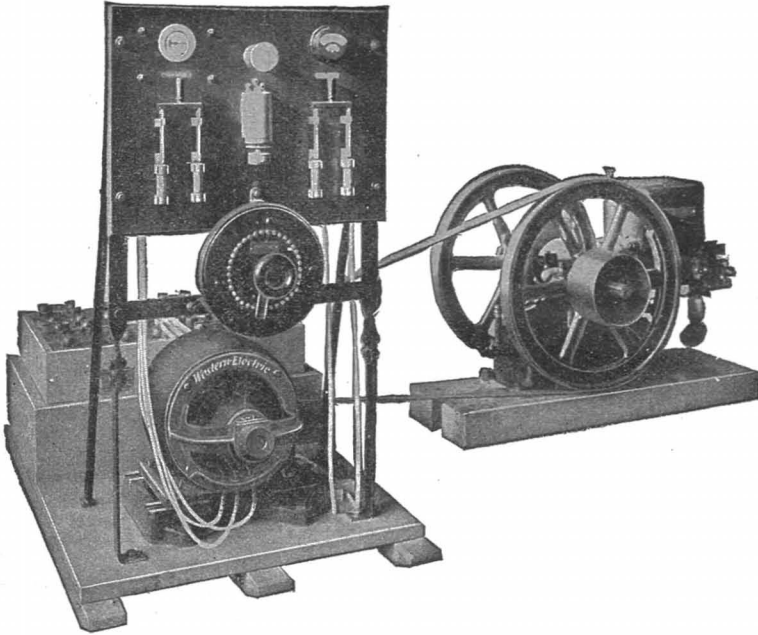

Complete plant ready for operation. Engine not included in outfit

### Description

Each of the outfits consists of an electric generator which either furnishes electricity for immediate use or charges up the storage battery, a storage battery which furnishes the electricity while the engine is not running, and a switchboard. You use your own engine to drive the generator when the battery gets empty, or we furnish an engine if you so desire.

We supply several sizes and styles of these plants so that any condition can be economically suited.

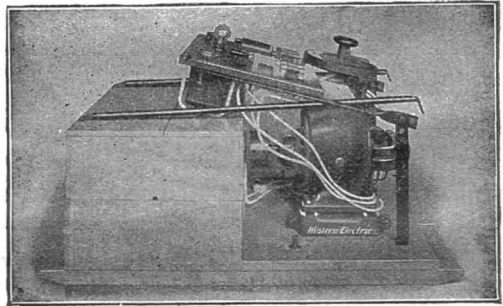

The Complete Outfit Unpacked

Our Nos. 1, 2, 3 and 4 outfits are shipped complete, set up and charged ready for use except the engine which we only furnish when it is so ordered. The generator, battery and switchboard are arranged substantially as shown in the top illustration. Upon receipt of the outfit, the side and top boards are knocked off, the switchboard unfolded and the house wires joined on. The electricity can then be turned on at will.

In our Nos. 9 and 10 outfits, the units making up the outfits are packed separately and are to be assembled where used. These latter two outfits are lower in price than the others, but are quite satisfactory in all respects.

We will send you on request a copy of our book "Brightening Up the Farm" containing full descriptions, listings and data on our electric light outfits, together with directions on how to wire your house (if you have to do this yourself).

Address our nearest house.

Telephone Apparatus and Supplies

398

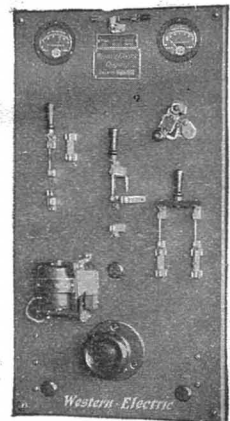

The Switchboard of our Nos. 9 and 10 Outfits

## SMALL ELECTRIC LIGHT OUTFITS

## List Prices of Outfits

## OUTFIT No. 1—LIST No. 3075

Net Price

<b>Generator</b> —Western Electric Type B, 20 amperes, 32-42 volts.....	}	\$227.75
<b>Battery</b> —16 cells, Type DDR-5.....		
<b>Switchboard</b> —Type E, 30 amperes.....		

Above mounted on skids, connected, packed and crated.

## OUTFIT No. 2—LIST No. 3076

<b>Generator</b> —Western Electric Type B, 20 amperes, 32-42 volts.....	}	\$263.63
<b>Battery</b> —16 cells, Type EER-5.....		
<b>Switchboard</b> —Type E, 30 amperes.....		

Above mounted on skids, connected, packed and crated.

## OUTFIT No. 3—LIST No. 3459

<b>Generator</b> —Western Electric Type B, 30 amperes, 32-42 volts.....	}	\$304.71
<b>Battery</b> —16 cells, Type EER-7.....		
<b>Switchboard</b> —Type E, 30 amperes.....		

Above mounted on skids, connected, packed and crated.

## OUTFIT No. 4—LIST No. 3460

<b>Generator</b> —Western Electric Type B, 45 amperes, 32-42 volts.....	}	\$377.11
<b>Battery</b> —16 cells, Type EER-9.....		
<b>Switchboard</b> —Type E, 60 amperes.....		

Above mounted on skids, connected, packed and crated.

## OUTFIT No. 5—LIST No. 3461

<b>Generator</b> —Western Electric Type B, 45 amperes, 32-42 volts.....	}	\$408.16
<b>Battery</b> —16 cells, Type EER-11.....		
<b>Switchboard</b> —Western Electric 60 ampere type.....		

Above mounted on skids, connected, packed and crated.

## OUTFIT No. 6—LIST No. 3462

<b>Generator</b> —Western Electric Type B, 60 amperes, 32-42 volts.....	}	\$439.21
<b>Battery</b> —16 cells, Type EER-13.....		
<b>Switchboard</b> —Western Electric 60 ampere type.....		

Above mounted on skids, connected, packed and crated.

## OUTFIT No. 7—LIST No. 3463

<b>Generator</b> —Western Electric Type B, 60 amperes, 32-42 volts.....	}	\$468.88
<b>Battery</b> —16 cells, Type EER-15.....		
<b>Switchboard</b> —Type E, 60 amperes.....		

Above mounted on skids, connected, packed and crated.

## OUTFIT No. 8—LIST No. 3464

<b>Generator</b> —Western Electric Type B, 60 amperes, 32-42 volts.....	}	\$499.24
<b>Battery</b> —16 cells, Type EER-17.....		
<b>Switchboard</b> —Type E, 60 amperes.....		

Above mounted on skids, connected, packed and crated.

## OUTFIT No. 9—LIST No. 9

<b>Generator</b> —Western Electric Type B, 20 amperes, 32-42 volts.....	}	\$220.00
<b>Battery</b> —16 cells, Type DDR-5.....		
<b>Switchboard</b> —Western Electric, 30 ampere type.....		

Above not mounted on skids or connected. Each item shipped separately to be set up by purchaser.

## OUTFIT No. 10—LIST No. 10

<b>Generator</b> —Western Electric Type B, 20 amperes, 32-42 volts.....	}	\$245.00
<b>Battery</b> —16 cells, Type EER-5.....		
<b>Switchboard</b> —Western Electric, 30 ampere type.....		

Above not mounted on skids or connected. Each item shipped separately to be set up by purchaser.

# Western Electric

## BATTERY LANTERN



One Cell Type

The Western Electric lantern is needed by everyone indoors or outdoors. In the house it is needed whenever you have to go in the dark, or look in a closet or unlighted place for anything. On the farm its uses are legion, in the barn, the dairy, the stable, the hayloft, the pasture, the orchard, the garden. To the storekeeper it is invaluable. To the camper, the automobilist, the motor-boater, the watchman, the grocer, every mechanic, storekeeper or artisan this lantern is a necessity.

This lantern has many new points. The light rays are gathered together and shot out in a long, concentrated beam which will illuminate an object 200 feet distant. The reflector is exceptionally large and has great reflecting powers. It is 4 inches in diameter and is a true parabola like the headlight of an automobile. It is made of solid brass, heavily plated.

You turn on the light by turning the entire reflector, a most ingenious arrangement of contacts acting as the switch. This does away with all moving parts outside the lantern to corrode or become loosened and, by entirely dispensing with slots, keeps out moisture.

Metallic objects cannot touch the live parts and waste the battery, nor can the light be turned on accidentally.

There is a swinging bail for convenience in carrying which serves as a handle and also locks the top on, absolutely preventing the top coming off and thereby injuring the lamp or reflector.

A rigid handle is also provided and has a slot in it by which it can be hung on a nail.

The lamp bulb is one of the latest, high efficiency Mazda electric tipless lamps and is most carefully adjusted for satisfactory service.

The metal case of the lantern is finished with two coats of genuine automobile lamp black enamel. Every part of the case is insulated from the electric current.

We recommend Western Electric Red Label battery as the most satisfactory, but any fresh No. 6 battery with either flush or protruding carbon terminals may be used.

Where a stronger light is needed use the two cell lantern. This gives a more powerful light for the same period than the one cell lantern.



Two Cell Type

	Net Price
One Cell . . . . .	\$1.25
Two Cell . . . . .	1.75

Batteries not included.

## INDEX

Material	A	Page	Material	Page
Alcohol Torches		395	Boxes, Jack	109
Alley Arm Braces		326	Braces, Alley Arm	326
Ammeters, Battery		30	Braces, Back	312
Anchors, Guy	314	315	Braces, Bit	363
Anchor Rods		314	Braces, Crossarm	312
Annunciator Wire		348	Brackets, Pole	310
Apartment House Inter-phones	256	270	Brackets, Telephone	279
Apparatus Blanks		16	Brackets, Transmitter	294
Apparatus Boxes		16	Brackets, Transposition	311
Apparatus Cases, Selector		152	Brick Drills	389-390
Arms, Cable		325	Bridle Cable	49
Arms, Telephone	278	279	Bridle Rings	330
Arms, Transmitter		293	Bridle Wire	347
Arresters, Lighting	132	134	Bridge Unit, 1407A Type	282-284
Arresters, Vacuum		133	Bridges, Testing	284-286
Artificial Lines and Cables		284	Bridging Connectors	350
Augers, Earth		356	Buffalo Grips	361
Automobile Telephones		57	Butt Plates	325
Axes		375	Buzzers, A.C.	36
			Buzzers, D.C. Iron Box	36
	<b>B</b>			<b>C</b>
Backboards		17	Cabinets, Battery	30
Back Braces		312	Cabinets, Interruption	131
Bags, Tool		374	Cabinets, Protector	135
Bands, Pole		329	Cabinets, Storage Battery	31
Bars, Digging		355	Cable, Bridle	49
Bars, Tamping		355	Cable, Composite	48
Batteries, Blue Bell		17	Cable, Emergency	49
Batteries, Blue Stone		19	Cable, Ferrin Circular Loom	49
Batteries, Dry	17	18	Cable, Inter-phone	52
Batteries, Edison Primary		21	Cable, Lead Covered Telephone	40-52
Batteries, Eveready		18	Cable, Submarine	48
Batteries, Gravity		19	Cable, Switchboard	50-51
Batteries, Liquid		19	Cable Arms	325
Batteries, Oval Columbia		18	Cable Boxes	53-55
Batteries, Sal-ammoniac		19	Cable Cars	366
Batteries, Samson		19	Cable Clamps	330
Batteries, Silver Chloride Testing		18	Cable Grips	367
Batteries, Storage	22	27	Cable Hangers	328
Battery Boxes		36	Cable Pastors	353
Battery Cabinets		31	Cable Reel Wheels	359
Battery Connectors		20	Cable Rings	329
Battery Coppers		19	Cable Rollers	366
Battery Charging Units		123	Cable Splicing Joints	331
Battery Gauges		30	Cable Terminals	53-55
Battery Lanterns		400	Calculagraphs	56
Battery Meters		30	Cameron Rings	329
Battery Sets, Patterson	32	35	Cant Hooks	357
Battery Supplies		19	Caps, Lamp	119-120
Battery Thermometers		28	Capstans	365
Battery Zincs		19	Carbon Blocks, Protector	137
Beeswax		353	Carrying Hooks	357
Bell Ringing Transformers		289	Cedar Poles	306-308
Bells, A.C.		91	Central Office Tools	287-288
Bells, D.C. Iron Box		36	Chairs, Operators	56
Bells, Extension		91	Charging Generators	123-124
Belts, Linemen's		368	Charging Machines	123-124
Binding Posts		37	Chau-phones	57
Bit Braces		383	Chestnut Poles	306-308
Bit, Wood Drill		383	Chisels	375
Bits, Auger		385	Chronoscope	58
Bits, Expansion		386	Church Telephones	56
Blake Insulated Staples		343	Circuit Breaker	58
Blanks, Apparatus		16	Circular Loom Cables	49
Blocks, Protector		137	Clamps, Cable	330
Blocks, Pulley	362	364	Clamps, Guy	316-317
Blue Bell Batteries		17	Clamp, Line Tapping	301
Blue Vitriol		19	Clamps, Messenger	318
Bolts, Brace and Crossarm		319	Clamps, Pole	318
Bolts, Double Arming		320	Clamps, Splicing	371
Bolts, Expansion		323	Cleats, Blake Compressed	343
Bolts, Expansion Rings		330	Cleats, Fiber	342
Bolts, Eye		327	Cleats, Porcelain	340
Bolts, Lag		320	Clips, Wire Rope	317
Bolts, Toggle		324	Code Signaling System	127-128
Booth Switch		158	Coils, Heat	100
Booths, Folding Door		38	Coils, Induction	101
Booths, Telephone	38	39	Coils, Repeating	143-144
Boring Machines		384	Coils, Retardation	147-148
Bossing Stick		396	Coin Boxes	59
Boxes, Apparatus		16	Coin Collectors	59
Boxes, Battery		36	Columbia Oval Batteries	18
Boxes, Cable	53	55	Combined Jacks and Signals	60-63
Boxes, Desk Set	81	83	Come Alongs	361-362
Boxes, Hand Generator		97	Composite Cable	48

Material	Page	Material	Page
Compound, Western Electric	353	Furnace Soldering Iron	395
Condensers	64	Fuse Blocks	95
Condenser Straps	64	Fuse Posts	95
Conduit	335-338	Fuses	94
Connecting Blocks	58	Fuses, Telegraph	94
Connectors, Battery	20		
Connectors, Bridging	350	<b>G</b>	
Connectors, Fahnestock	350	Galvanized Iron Wire	344
Connectors, Sleeve	349	Galvanizing	305
Connectors, Test	350	Gasoline Torches	395
Coppers, Battery	19	Gauges, Battery	30
Copper Clad Wire	345	Gauges, Wire	392
Cords	65	Generator Parts	98
Cords, Desk Stand	72	Generators, Charging	123-124
Cords, Receiver	71	Generators, Hand	96-98
Cords, Switchboard	65-67	Generators, Power	96
Cords, Transmitter	73	Generators, Ringing	125-126
Cord Fasteners	75	Gimlets	375
Cord Hooks	75	Glass Insulators	339-340
Cord Pulleys	75	Gloves, Rubber	373
Cord Tips	76	Gong Mountings	99
Cord Weights	75	Gong Nuts	99
Cordless Jack Boxes	109	Gongs	99
Cotton Sleeving	353	Gravity Batteries	19
Counters, Peg	77	Gray Pay Stations	50
Crosby Clips	317	Grips, Buffalo	361
Crossarms	309	Grips, Cable	367
Crossarm Braces	312	Ground Cones	327
Cross Connecting Wire	348	Ground Rods	327
Crowfoot Zincs	19	Ground Strips	99 and 133
Curve Block	318	Ground Wire	347
Cut-in Station	77	Groups, Protector	136
		Guy Anchors	314-315
<b>D</b>		Guy Clamps	316-318
Deadmen	358	Guy Hooks	312
Desk Set Boxes, Central Battery	81-82	Guy Shims	325
Desk Set Boxes, Magneto	83	Guy Strand	313
Desk Stand Cords	72		
Desk Stands	79-80	<b>H</b>	
Designation Strips	78	Hack Saws	388
Digging Bars	355	Hand Generator Boxes	97
Dinkeys, Pole	359	Hand Generators	96-98
Distributing Frame Wire	348	Hand Set Hanger	100
Distributing Frames	84-86	Hand Sets	100
Distributing Rings	87	Hanger, Hand Set	100
Distributing Wire	346-347	Hangers, Cable	328
Double Tube Connectors	349	Hard Drawn Copper Wire	345
Draw Knife	375	Heat Coils	100
Dresser, Boxwood	396	Hammers	375 and 387
Drill, Wood	383	Hook Switches	159
Drills, Brick and Stone	389-390	Howlers	100
Drills, Hand and Breast	380-382	Hub Plates	325
Drop Mountings	88	Hydrometer Jar	29
Drop Wire	346-347	Hydrometers, Storage Battery	28
Drops	87, 89, 90		
Drop Spaces	88	<b>I</b>	
Dry Batteries	17-18	Induction Coils	101
Duct Rods	366	Insulated Staples	343
Duster, Universal	88	Insulating Tapes	352
Dynamotors, Ringing	125	Insulators, Glass	339-340
		Insulators, Porcelain	340
<b>E</b>		Inter-phone Cable	52
Edison Primary Batteries	21	Inter-phone Outfits	275-277
Electric Light Outfits	397-399	Inter-phones	227-277
Electric Soldering Irons	393	Inter-phones, Apartment House	256-270
Electrolyte Tester	29	Interrupter Battery Cabinets	31
Emergency Cable	49	Interrupter Ringing Outfits	105
Eveready Batteries	18	Interrupters	102-105
Expansion Bolts	323	Interior Wire	348
Extension Bells	91	Iron Box Bells, D.C.	36
Extension Bit Holder	383	Iron Box Buzzers, D.C.	36
Extinguishers, Fire	92		
Eye Bolts	327	<b>J</b>	
		Jack Boxes	109
<b>F</b>		Jack Fasteners	109
Factory Call System	127-128	Jack Mountings	109-110
Fahnestock Connectors	350	Jack Straps	368
Fanning Strips	92	Jacks	106-108
Fiber Cleats	342	Jacks, Cable Reel	365
Fire Extinguishers	92	Jacks, Pole	108
Fire Pots	395	Jacks, Restaurant	108
Flameproof Wire	348	Joints, Cable Splicer	331
Flashing Recall Outfit	93		
Foot Switch Attachments	92	<b>K</b>	
Foot Switches	92	Key Boxes	114 and 116
Frames, Distributing	84-86	Key Cases, Selector	153
<b>Telephone Apparatus and Supplies</b>	<b>402</b>		

Material	Page	Material	Page
Key Levers	117	Pole Bands	329
Key Mountings	117	Pole Changers	102
Key Spaces	117	Pole Changers, Rotary	126
Keys	111-118	Pole Changers, Telegraph	302
Keys, Selector	152	Pole Counter	376
Keys, Telegraph	295	Pole Jacks	108
Knife Switches	158-159	Pole Platform	332
Knives	377	Pole Protection Strips	325
Knives, Cable	396	Pole Seats	332
Knob Racks and Fixtures	333	Pole Specifications	306
Knobs, Porcelain	342	Pole Steps	321
<b>L</b>			
Ladle, Solder	394	Poles, Wood	306-308
Lag Bolts or Screws	320	Police Telephones	225
Lamp Caps	119-120	Porcelain Cleats	340
Lamp Socket Mountings	121	Porcelain Insulators	340
Lamp Sockets	120	Porcelain Knobs	342
Lamps, Switchboard	119	Porcelain Tubes	341
Lanterns, Battery	400	Portable Storage Batteries	26-27
Lead Covered Telephone Cable	40-52	Portable Telephones	218-221 and 281
Leather Nail Heads	343	Post Hole Digger	356
Levers, Key	117	Pothead Wire	347
Lightning Arresters	132-134	Pulley Blocks	362-364
Line Insulating Transformers	289	Pulleys, Cord	75
Linemen's Vises	376	Push Buttons	137
Line Poles	122	<b>R</b>	
Line Tapping Clamp	301	Railway Telephones	215-221
Liquid Batteries	19	Reamers	387
Locke Rings	329	Receivers	138-139
<b>M</b>			
Machines, Charging	123-124	Receiver Cords	71
Machines, Ringing	125-126	Rectifiers, Mercury Arc	140
Manhole Skids and Sheaves	366	Reels, Wire	360
Mattocks	356	Registers, Message	129
Measuring Tapes	391	Relays	141-142
Mechanical Code Signaling Systems	127-128	Relays, Telegraph	298-299 and 301
Mercury Arc Rectifiers	140	Repeating Coils	143-144
Message Registers	77 and 129	Repeating Coil Groups	143-144
Messenger Clamps	318	Resistances	145-146
Mica Fuses	94	Resistance Lamps	146
Micas, Protector	137	Resonators, Telegraph	304
Micrometer Caliper	392	Retardation Coils	147-148
Milonite Nails	343	Ringers	149-151
Mine Rescue Telephones	213-214	Ringer Indicators	150
Mine Signaling Systems	211	Ring Bolts, Expansion	330
Mine Telephones	208-214	Rings, Bridle	330
Monkey Wrenches	36	Rings, Cable	329
Motor Generator Ringing Sets	126	Rings, Distributing Frame	87
Mounting Plates	129	Rollers, Cable	366
<b>N</b>			
Number Plates	130	Rotary Pole Changers	126
<b>O</b>			
Operators' Chairs	56	Rubber Gloves	373
<b>P</b>			
Paper Sleeves	352	Rubber Tubing	352
Paraffin	353	<b>S</b>	
Paste, Soldering	351	Safety Straps	368
Pasters, Cable	353	Sal-ammoniac	19
Patterson Battery Sets	32-35	Salts, Soldering	351
Pay Stations	59	Samson Batteries	19
Peavies	357	Saw, Cableman's	396
Peg Counters	77	Saws, Hack	388
Pencil Zines	19	Saws, Wood	388
Phantom Repeating Coils	144	Scissors	377
Picks	356	Scrapers, Cable	396
Pike Poles	357-358	Screw Drivers	379-381
Pins, Crossarm	310	Screws, Lag	320
Pipe Wrenches	386	Screws, Wood	322
Protector Blocks	137	Seats, Pole	332
Protector Cabinets	135	Selectors	152
Protector Groups	136	Selector Apparatus Cases	152
Protector Micars	137	Selector Keys	152
Protector Mountings	137	Selector Key Cases	153
Protectors	132-134	Selector Key Spaces	153
Protectors, Central Office	134	Selector Sets	154
Platform, Pole	332	Semaphore	155
Pliers	369-370	Shims, Guy	325
Plugs	131	Shovels	354
Plug Seats	131	Signal Groups	156
		Signal Mountings	157
		Signal Plugs	157
		Signals	156
		Signals, Supervisory	158
		Silver Chloride Testing Batteries	18
		Sleeve Connectors	349
		Sleeves, Paper	352
		Sleeving, Cotton	353
		Solder	351

Material	Page	Material	Page
Solder Ladle	394	Telephone Arms	278-279
Solder Pot	394	Telephone Booths	38-39
Soldering Coppers	394	Telephone Brackets	279
Soldering Furnace	394	Telephone Terms	193-198 and 222
Soldering Irons, Electric	393	Terminals, Cable	53-55
Soldering Iron Furnace	395	Terminal Punchings	280
Soldering Paste	351	Terminal Strips	280
Soldering Salts	351	Test Connectors	350
Soldering Sticks	351	Test Sets, Cablemen's	281
Sounders, Telegraph	296-297	Test Sets, Linemen's	281
Speed Indicator	392	Testing Apparatus	281-286
Splicing Clamps	371	Testing Cabinet, 1407 Type	282-283
Splicing Wrenches	372	Thermometers, Battery	28
Spoons	354	Thimbles, Wire Rope	317
Stands, Desk	79-80	Tie Wrench	372
Staples, Blake Insulated	343	Toggle Bolts	324
Steel Pole Gains	326	Tool Bags	374
Steps, Pole	321	Tool Belts	368
Stillson Wrenches	386	Tool Kits	378-379
Stone Drills	389-390	Tool Sets, Pocket	377
Storage Battery Cabinets	31	Tools, Central Office	287-288
Storage Batteries	22-27	Tools, Switchboard	287-288
Storage Batteries, Portable	26-27	Torches, Alcohol	395
Strain Plates	312	Torches, Gasoline	395
Strand, Galvanized	313	Transformers, Bell Ringing	289
Straps, Condenser	64	Transformers, Line Insulating	289
Street Railway Telephones	217 and 219	Transmitters	290-292
Subscribers' Sets	158	Transmitter Arms	293
Submarine Cable	48	Transmitter Attachments	294
Supervisory Signals	158	Transmitter Brackets	294
Switchboards, 1800 Type	163-165	Transmitter Cords	73
Switchboards, 1200 Type	166-169	Transposition Brackets	311
Switchboard Cable	50-51	Tree Trimmers	376
Switchboard Cords	65-67	Tree Wire	346
Switchboard Installations	190-191	Trouble Caps	294
Switchboard Lamps	119	Tubes, Porcelain	341
Switchboard Terms	160-162	Tubing, Rubber	352
Switchboard, Telegraph	303	Turnbuckles	334
Switchboard Tools	287-288	Turning Pin, Boxwood	396
Switchboard Wire	348		
Switchboards, Central Battery Multiple	174-176	<b>V</b>	
Switchboards, Central Battery Non-multiple	172-173	Vacuum Arresters	133
Switchboards, Convertible	177	Van Akin Telephone Arms	279
Switchboards, Cordless	189	Vises, Linemen's	376
Switchboards, Definitions of Terms	160-162	Voltmeters, Battery	30
Switchboards, Magneto	163-171		
Switchboards, Multiple Magneto	177	<b>W</b>	
Switchboards, P.B.X.	186-189	Washers, Galvanized	325
Switchboards, Pony	171	Wax Compound	353
Switchboards, Private Exchange, 1801 Type	181-185	Weatherproof Wire	346
Switchboards, Toll	178-180	Weights, Cord	75
Switchboards, Wall Type	170	Wheatstone Bridges	286
Switch Hooks	159	Wheels, Cable Reel	359
Switches	158-159	Wiping Cloths	394
Switches, Table Jack	304	Wire, Annunciator	348
Switching and Testing Panels	159	Wire, Bridle	347
Syringes, Battery	29	Wire, Copper Clad	345
		Wire, Cross Connecting	348
<b>T</b>		Wire, Distributing	346-347
Tamping Bars	355	Wire, Distributing Frame	348
Tape, Cotton	352	Wire, Drop	340-347
Tape, Insulating	352	Wire, Flameproof	348
Tapes, Measuring	391	Wire, Galvanized Iron	344
Tape, Okonite	352	Wire Gauges	392
Telegraph Apparatus	295-304	Wire Grips	361-362
Telegraph Fuses	94	Wire, Ground	347
Telegraph Keys	295	Wire, Hard Drawn Copper	345
Telegraph Relays	298-299 and 301	Wire, Interior	348
Telegraph Resonators	304	Wire Measuring Machine	392
Telegraph Switchboards	303	Wire, Pothead	347
Telephones	192-277	Wire Skinner	377
Telephones, Definitions of Terms	193-198	Wire, Switchboard	348
Telephones, Central Battery	222-226	Wire, Tree	346
Telephones for Use with 1801 Switchboards	226	Wire, Weatherproof	346
Telephones, Magneto	197-221	Wood Screws	322
Telephones, 1317 Type	199-204	Wrench, Lag Screw	372
Telephones, 1305 Type	205	Wrench Splicing	372
Telephones, Magneto Desk	206-207	Wrench, Tie	372
Telephones, Mine	208-214	Wrenches, Monkey	386
Telephones, Mine Rescue	213-214	Wrenches, Pipe	386
Telephones, Police	225	Wrenches, Stillson	386
Telephones, Portable	218-221 and 281		
Telephones, Railway	215-221	<b>Z</b>	
Telephones, Railway Composite	217-218	Zincs, Battery	19
Telephones, Rope Haulage System	212		
Telephones, Street Railway	217 and 219		
Telephone Apparatus and Supplies	404		

**SAVE TIME AND FREIGHT**



**TELEPHONE OUR NEAREST HOUSE**