

4008 Program Amplifier★

contents

section 1	general description	page 1
section 2	application	page 2
section 3	installation	page 4
section 4	circuit description	page 8
section 5	block diagram	page 9
section 6	specifications	page 8
section 7	testing and troubleshooting	page 10

1. general description

1.01 The Tellabs 4008 Program Amplifier (figure 1) is a single-channel, wideband, low-distortion amplifier designed for use in program transmission applications. An integral amplitude equalizer provides switch-selectable, adjustable, precision equalization of nonloaded cable for 8kHz or 15kHz program circuits, with capability of greater than 30dB slope correction. With the equalizer removed (also by switch selection), the amplifier response is essentially flat (± 1 dB) from 20Hz to 20kHz.

1.02 The 4008 provides from 0 to 40dB of adjustable gain in switch-selectable 10dB increments (0 to 10dB, 10 to 20dB, 20 to 30dB, or 30 to 40dB). Within each increment, gain is continuously adjustable via a front-panel potentiometer. Maximum output is +20dBm.

1.03 When used to provide precision amplitude equalization in 5, 8, or 15kHz program circuit applications, an active equalizer is used to compensate for the frequency response of nonloaded telephone cable, and equalization is controlled by adjustment of three potentiometers accessed through the module's front panel. Two adjustments, one for high frequencies and one for low frequencies, establish the equalizer response shape. A third adjustment provides response "trimming" at very low frequencies. The composite equalizer is capable of slope correction in excess of 30dB for various lengths and gauges of nonloaded telephone cable. Equalization to within ± 1 dB is achievable for either 8kHz or 15kHz circuits. Adjustment is precise and can be accomplished with relative ease. Roll-off is provided at approximately 10kHz in the lower of the two switch-selectable equalization ranges, and at 20kHz in the higher range.

1.04 The 4008 is designed to operate between 600 ohm balanced or 150 ohm balanced or unbalanced source and load impedances. Input and output impedances are each independently switch-selectable for 150 or 600 ohms. Input and output impedances are not affected by insertion of the active amplitude equalizer.

1.05 Secondary lightning protection is provided at both ports of the Amplifier, including surge current limiting resistors in both input and output

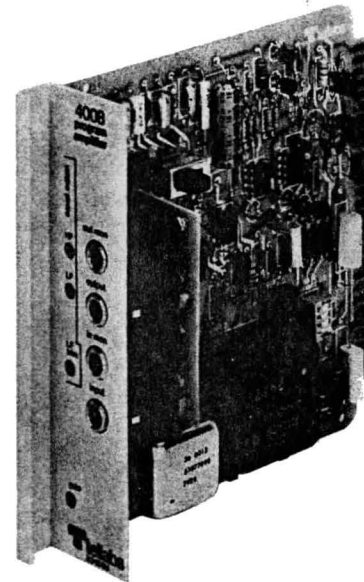

figure 1. 4008 Program Amplifier

paths. Transient protection is also provided for the power regulating circuit in the Amplifier.

1.06 The 4008 is designed to operate on any input voltage between -23 and -56 Vdc. Current drain is 50mA at maximum output and 35mA quiescent.

1.07 Use of tantalum capacitors and other carefully chosen components permits operation of the 4008 within the temperature range of -40° to $+140^{\circ}$ Fahrenheit.

1.08 The front panel of the 4008 is designed so that adjustments can be made while the module is mounted in place. Front-panel gain and equalization controls are complemented by a full set of test jacks (input, output, input monitor, and output monitor) to facilitate alignment and testing of the module.

1.09 A Type 10 module, the 4008 mounts in one position of a Tellabs Type 10 Mounting Shelf, versions of which are available for relay rack or apparatus case installation. In relay rack applications, up to 12 modules may be mounted across a 19-inch relay rack, while up to 14 modules may be mounted across a 23-inch rack. In either case, 6 inches of vertical rack space is used.

1.10 As a member of Tellabs' 248 Group of Program Transmission equipment, the 4008 may also be mounted in any of Tellabs' prewired Type 248 Mounting Assemblies, which are available in both apparatus-case and rack-mounted-shelf versions.

The 248A and 248B Assemblies are, respectively, single-module wall-mounted and two-module desk-top or wall-mounted apparatus cases (see figures 2 and 3). A special wall-mounted Assembly, the 248RF (figure 4), provides both mounting and effective RF shielding for two 4008 modules. Pre-wired 19 and 23-inch relay-rack-mounted Shelf Assemblies, the 248C through 248G, are also available. Further information is available in Tellabs' practices and catalog sheets describing the 248 Assemblies and the 4012 and 4018 Program Distribution Amplifiers.

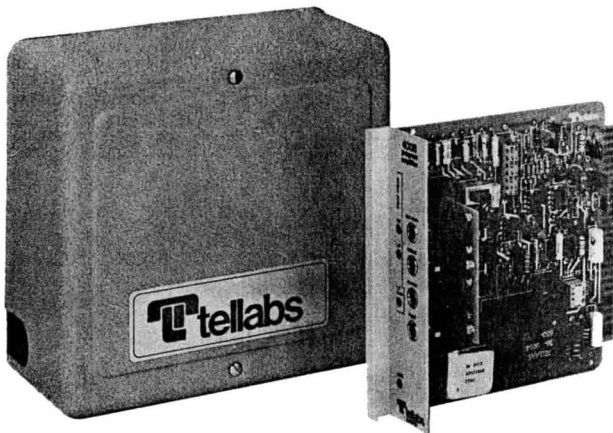

figure 2. 248A Program Amplifier Assembly

2. application

2.01 Tellabs' 4008 Program Amplifier module provides the amplification, amplitude equalization and low harmonic distortion necessary for the transmission of high quality, wideband audio signals over nonloaded telephone cable. As such, the 4008 finds primary application as a program amplifier, conditioning the transmission facility (i.e., nonloaded telephone cable) from a radio or television station to a transmitter site, or from a remote pickup point to a studio or transmitter site. Standard 5kHz (am), 8kHz (television audio), or 15kHz (fm) bandwidth signals may be accommodated.

2.02 The 0 to 40dB gain range of the 4008, in conjunction with its +20dBm maximum output level, provides adequate amplification for applications within the limits of good transmission design. The four gain ranges (0 to 10dB, 10 to 20dB, 20 to 30dB, and 30 to 40dB) are selected via a DIP switch on the 4008's printed circuit board. Fine adjustment within each range is accomplished by means of a front-panel potentiometer. Gain may be easily set to any level ± 0.1 dB within the overall 0 to 40dB range.

2.03 The active equalizer in the 4008 is capable of inversely matching the slope of nonloaded telephone cable from either 50Hz to 15kHz or from 100Hz to 8kHz, where the loss differential between the lowest and the highest frequencies of interest is between 0 and 31dB. Equalizer response is independent of amplifier gain, permitting independent adjustment of facility frequency response and loss (or gain). Equalizer slope is matched to cable characteristics through adjustment of two potentiometers

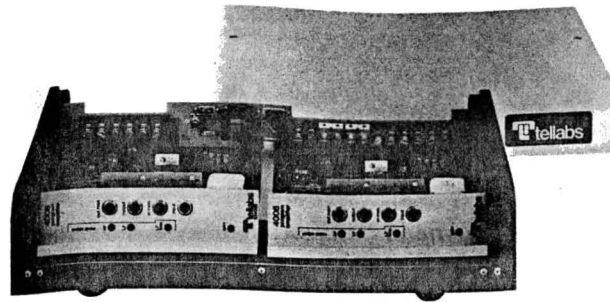

figure 3. 248B Program Amplifier Assembly

labeled *HF* (high frequency) and *LF* (low frequency) on the module's front panel. A third front-panel potentiometer, labeled *LF trim*, is provided to "trim" low-frequency (below 200Hz) response after primary equalization has been achieved. A composite frequency response for cable and amplifier that is flat within ± 1 dB from either 50Hz to 15kHz or from 100Hz to 8kHz can be achieved with the 4008's equalizer.

2.04 Slope equalization provided by the active equalizer is limited to a loss differential of about 31dB between lowest and highest frequencies of interest. This limit is translated to equivalent cable lengths in tables 1 and 2. Table 3 lists the loss per kilofoot of various gauges of cable at both 8kHz and 15kHz.

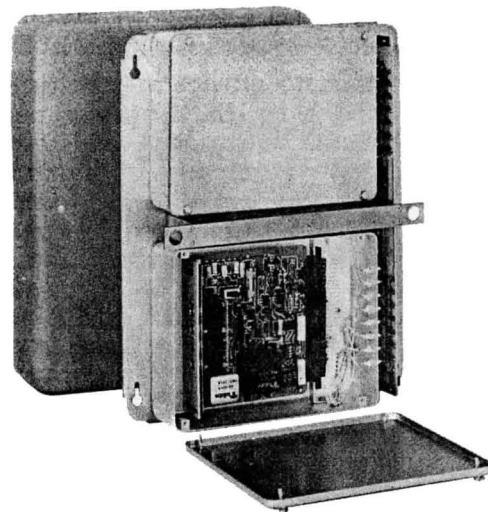

figure 4. 248RF Program Amplifier Assembly

2.05 When equalization is not required, the 4008's equalization circuitry may be removed from the transmission path via switch option. In this mode, the 4008 provides flat gain from 20Hz to 20kHz, with roll-off below 20Hz and above 20kHz.

2.06 Equalizer response is unaffected by choice of input and output impedance, but, in general, use of 150-ohm cable interface impedances will permit equalization of longer cable sections than will 600-ohm impedances. (The 150-ohm impedance-matching option presents an impedance mismatch that provides a nominal degree of slope equalization for nonloaded telephone cable.)

Note: The 4008 is designed for use in balanced transmission facilities when optioned for 600-ohm impedances. Capacitors are connected between the midpoints of the input and output transformers and external connector pins, and these pins may be grounded (either to power-supply ground or to local ground) to improve longitudinal balance. These capacitors will seriously degrade amplifier performance if the unit is connected to an unbalanced 600-ohm source or load. The capacitors are electrically removed from the circuit when the 4008 is optioned for 150-ohm impedance, permitting use of the amplifier in this mode with unbalanced source and/or load terminations.

cable gauge	maximum length	cable loss at equalization limit (600Ω terminations)	
		1kHz	8kHz
19	61.5kf	15.3dB	41.5dB
22	40	13.6	41.0
24	30	12.2	38.5
26	24	12.8	38.0

table 1.
Approximate maximum equalization ranges — 5kHz and 8kHz program circuits

cable gauge	maximum length	cable loss at equalization limit (600Ω terminations)	
		1kHz	15kHz
19	46.0kf	11.5dB	42.5dB
22	31.2	10.5	45.6
24	22.2	8.8	40.8
26	18.0	9.5	40.4

table 2.
Approximate maximum equalization limits — 15kHz program circuit

cable gauge	loss/kf at 8kHz	loss/kf at 15kHz
19	0.675dB	0.924dB
22	1.025	1.462
24	1.283	1.838
26	1.583	2.244

table 3. Loss per kilofoot of cable

2.07 A switch provides somewhat closer adaptation of the 4008's equalization to long loops or short loops — long loops being those with greater than 17dB loss at the highest frequency of interest. Considerable overlap in the two ranges is provided by the 4008's front-panel controls.

2.08 The 4008 may be physically located at any point in the circuit, but since post-equalization is preferable to pre-equalization, the terminating end of the facility is generally chosen. (It is easier to post-equalize because the installer can see the results of equalizer changes as adjustments are made. In addition, pre-equalization may create crosstalk problems due to higher than desirable transmission levels at the high-frequency end.) Because the terminating end of the facility to which the 4008 is normally applied may very well be an unheated equipment enclosure or shed, the module is designed to operate over a -40° to $+140^{\circ}$ F temperature range.

2.09 As a Type 10 module, the 4008 mounts in one position of a Tellabs Type 10 Mounting Shelf, versions of which are available for relay rack or apparatus case installation. For single-amplifier applications, a prewired apparatus case with an integral rectifier, the 248A Program Amplifier Assembly, is available. In applications where a stereo program circuit necessitates two independent Program Amplifiers, two 4008's may be mounted in a prewired 248B Program Amplifier Assembly. Both 248A and 248B may be provided with a receptacle-mounted ac stepdown transformer for operation from conventional 117Vac input. The 248A may also be provided with optional gas tube protection.

2.10 In applications characterized by a high RF environment, such as transmitter sites, a 248RF Assembly may be used. The 248RF Assembly provides RF-shielded mounting for two Program Amplifier modules. Shielding, along with RF decoupling circuitry for all transmission and power leads entering the 248RF Assembly, prevents the coupling of modulated RF energy into the Program Amplifiers' transistorized circuitry. The 248RF Assembly thus eliminates problems of instability, cross-coupling between am and fm signals, and extraneous noise pickup, allowing the 4008 Amplifiers to be located conveniently at the transmitter site.

2.11 Tandem operation may be accommodated by the 4008. Three Program Amplifiers may be used in tandem without exceeding the noise specifications of standard program circuits.

2.12 Power is supplied to the amplifier and equalizer circuits by means of an on-board voltage regulator that operates from input voltages between -23 and -56 Vdc. Maximum current requirement is 50mA at 20dBm output and 35mA in the quiescent state (-48 Vdc input).

2.13 The 4008 is designed to operate from a relatively well-filtered power source (0.5 volt maximum ripple) with positive ground. Some applications, however, may require that the Amplifier be located at an intermediate point where a local source of power is unavailable. Power may be provided to the 4008 over a separate cable pair, with a maximum resistance in the power-feed loop of 1000 ohms. A simplex power-feed arrangement may also be used. *In either case, however, the following precautions must be heeded to avoid introduction of 60Hz noise:*

(a) Remote powering via a separate cable pair is the preferred powering arrangement for remote location applications. The total resistance in the powering loop must not exceed 1000 ohms (48-volt supply). To minimize introduction of 60Hz noise resulting from longitudinal or metallic potentials on the power-feed loop, capacitive filtering at the remote location is highly recommended. A minimum of 50 microfarads capacitance is suggested, with a minimum dc rating of 150 volts. (A 130-volt varistor in the 4008 will protect the capacitor against momentary surge potentials exceeding 150 volts.) The filter capacitor should be

connected directly across the power pair at the remote location.

(b) Simplex leads are derived on the input and output transformers (600-ohm option only) to accommodate simplex powering at remote locations. This powering arrangement is not recommended, however, because of the likelihood of noise problems. If simplex powering is to be used, a capacitive filter should be used between the simplex lead and the return path (or ground, if ground return is used), and care must be taken to ensure that the simplex current is balanced (no more than 3mA of dc unbalance can be tolerated). A capacitor of at least 50 microfarads, with minimum 150 volt rating, should be used for power filtering.

(c) When the 4008 is powered via a separate cable pair at a remote location, several grounding arrangements are available to minimize introduction of 60Hz noise. These include optional grounding of the transformer midpoint capacitors to either local ground or to supply ground, optional ground of transformer shields to either ground, and provision of a separate ground connection for the front-panel-mounted jack sleeves. If 60Hz noise pickup is noted at a remote Amplifier site, a systematic "trial and error" approach to grounding is recommended.

2.14 The 4008's input and output ports may be accessed via input and output jacks located on the module's front panel. The jacks labeled *input* and *output* directly access the Amplifier ports, with the external connections opened while a 310-Type plug is inserted. Input and output monitor jacks, labeled *in mon* and *out mon*, are also provided for bridging access to the two ports, and, with a second plug inserted into the access jack, the external facility leads may be accessed through the appropriate monitor jack.

Note: When access is made to the input or output of the amplifier through the input or output jacks, the current-limiting resistors are bypassed. This will cause input and output impedances to appear 11.2 ohms lower than will be measured at the input and output connector pins, creating a 0.1dB difference in insertion loss with a 600-ohm termination and a 0.2dB difference with a 150-ohm termination.

3. installation inspection

3.01 The 4008 Program Amplifier module should be visually inspected upon arrival in order to find possible damage incurred during shipment. If damage is noted, a claim should immediately be filed with the carrier. If stored, the module should be visually inspected again prior to installation.

mounting

3.02 The 4008 module mounts in one position of a Tellabs Type 10 Shelf or Type 248 Mounting Assembly, both of which are available in configurations for both relay rack and apparatus case installation. The 4008 plugs physically and electrically in

to a 56-pin connector at the rear of the module's mounting position. For installation of a 248 Assembly, refer to the practice, schematic, or wiring drawing available on that Assembly.

installer connections

3.03 Before making any connections to the mounting shelf or assembly, make sure that power is off and modules are removed. Modules should be put into place only after they are properly optioned and after wiring is completed.

3.04 Table 4 lists external connections to the 4008 Program Amplifier. All connections are made via wire wrap at the 56-pin connector at the rear of the module's mounting position. Pin numbers are found on the body of the connector. In the case of the 248A and 248RF Assemblies, external connections are indicated on the 248A and 248RF Assemblies, and the 248B Assembly should be connected as per table 5.

connect:	to pin:
AMPLIFIER INPUT (TIP)	7
AMPLIFIER INPUT (RING)	13
INPUT SIMPLEX	9 and 11
INPUT SX CAPACITOR GROUND	21
SLEEVE GROUND (front-panel jacks)	55
AMPLIFIER OUTPUT (TIP)	5
AMPLIFIER OUTPUT (RING)	15
OUTPUT SIMPLEX	1 and 3
OUTPUT SX CAPACITOR GROUND	19
SHIELD GROUND (transformer)	23
-BATT (-23 to -56Vdc input)	35
GND (ground)	17

table 4. External connections to 4008 module mounted in Type 10 Shelf

connect:	to terminal block position:
AMP 1 (J1) in.	1 and 2
AMP 1 (J1) out.	4 and 5
SX IN	3
AMP 2 (J2) in.	6 and 7
AMP 2 (J2) out.	9 and 10
power in (-) 24Vdc or 18Vac input	-
power in (+) 24Vdc or 18Vac input	+
SX OUT	8
ground	ground lug on case

table 5. External connections to terminal block on 248B Assembly

ground connections

3.05 When the 4008 is located in a central office or at a location with local power, best results will be achieved when the transformer shield grounds are connected to the power-supply ground. The jack sleeves may be grounded either to frame ground or to power ground. At remote locations, the jack sleeves may be connected to local ground or left open, and the other grounds should be connected either to local ground or to power ground, whichever minimizes introduction of 60Hz noise.

3.06 If the 4008 is to be mounted in a 248A, 248B, or 248RF Assembly, power may be supplied via an ac power transformer (6VA) or via a local dc

power supply (24 to 56Vdc). In either case, the polarity of the input power voltage is immaterial, as the full-wave bridge rectifier provided in these Assemblies serves as a polarity guard for input dc potentials. It is important, however, that the local dc power supply be ungrounded when used with these Assemblies, and that a good connection be made from the ground lug on the apparatus case to a reliable source of local ground. (This ground connection is especially important when the 4008 is used in a 248RF Assembly at a transmitter site, where high RF fields are encountered.)

option selection

3.07 Six option switches must be set before the 4008 is aligned. These switches and their functions are described in paragraphs 3.08 through 3.12. Locations of these switches on the module's printed circuit board are shown in the condensed alignment, figure 5.

3.08 Two switches, labeled *Z IN* and *Z OUT*, are set to select the 4008's input (*Z IN*) and output (*Z OUT*) impedances. These switches select either 150-ohm or 600-ohm impedance-matching options. In general, the 150-ohm option is used to interface nonloaded cable, while the 600-ohm option is used to interface broadcast equipment. (The 150-ohm impedance-matching position provides a nominal degree of slope equalization for nonloaded cable.)

Caution: *If the 600-ohm impedance option is selected, the input and output connections to the 4008 must be balanced if the midpoint capacitors are grounded. Response measurements using unbalanced instruments will be in error. If 150-ohm impedance is used, the unit may be connected to either balanced or unbalanced source and load terminations.*

bandwidth

3.09 The bandwidth-selection switch is set for the program application in which the 4008 is to be used. The 8kHz-option is selected when the 4008 is used in standard am radio or television audio applications, while the 15kHz-option is selected when the 4008 is used in fm radio applications.

equalization

3.10 The *EQUAL* switch is set to enable or disable the 4008's integral equalization circuitry. In applications where equalization is required, set the *EQUAL* switch to the *IN* position to enable the equalizer. In applications where equalization is not required, set the *EQUAL* switch to the *OUT* position.

3.11 If equalization is used, the *LONG LPS/SHT LPS* switch must also be set to configure the equalization shape for either long or short loops. Set this switch to the *LONG LPS* position if the unequalized facility loss at the upper band edge

(either 8kHz or 15kHz) exceeds 17dB, or to the *SHT LPS* position if facility loss at 8kHz or 15kHz is less than 17dB.

gain

3.12 Switch selection of either the 0 to 10dB, 10 to 20dB, 20 to 30dB, or 30 to 40dB gain range is accomplished by setting the four-position *GAIN RANGE* DIP switch as indicated in table 6. (Fine adjustment within the selected 10dB range is made via the front-panel *gain* potentiometer during alignment of the module. This potentiometer is continuously adjustable over a range of approximately 11dB to ensure overlap of the major gain increments.) Switch positions are identified as left, center, and right, rather than by number, because the numbering of switch positions by the various switch manufacturers is not consistent. The left position refers to the leftmost switch position as the module is viewed from the connector end; center refers to the next adjacent switch position, etc. If equalization is not used, refer to the circuit level record (CLR) card and set the *GAIN RANGE* switch for the 10dB range that encompasses the required transmission level. If equalization is used, initially set the *GAIN RANGE* switch for the 10 to 20dB range, and reset the switch (if required) after equalization is completed. (Selection of the 10 to 20dB range will introduce sufficient gain to overcome the loss inherent in the equalizer, thus ensuring accurate equalization.) Again, precise level adjustment will be made via the *gain* potentiometer.

special note: *In some rare applications, it may be necessary to operate or test a circuit with a 4008 at very high input levels — beyond the specified +10dBm maximum input. (This may be the case when a radio station performs deviation and modulation tests or frequency runs.) While input levels below +10dBm will not produce distortion through the 4008, input signals between +10dBm and +20dBm may produce overload distortion unless the following precautions are taken:*

- 1) Use the Short Loops (*SHT LPS*) option for all loops with 1000Hz insertion loss below about 5dB (measured between 600-ohm source and load impedances).
- 2) Always set the *GAIN RANGE* switch for the 0 to 10dB range whenever the 4008 is operated in the *SHT LPS* mode. This gain step overcomes loss inherent in the equalizer in the *SHT LPS* mode.
- 3) Whenever practical, attempt to arrange signal levels and amplifier gain so that gain introduced by the front-panel 10dB *gain* potentiometer is minimized (fully counterclockwise). This means that gain should be introduced via the 10dB *GAIN RANGE* switch especially in relatively short loop applications.

*as viewed from connector end of module

gain range	left*	center*	right*	far right*
0-10dB	on/closed	on/closed	on/closed	unused
10-20dB	off/open	on/closed	on/closed	unused
20-30dB	off/open	off/open	on/closed	unused
30-40dB	off/open	off/open	off/open	unused

table 6. Switch selection of gain ranges

Note: Only three of the four positions on the GAIN RANGE switch are used. The switch position on the far right is unused.

alignment

3.13 The alignment procedure consists of sending test tones from the originating end of the circuit to the 4008, measuring the level of each tone at the 4008 with a test set, and adjusting the module's equalizer and amplifier appropriately. In tandem applications (i.e., more than one 4008 module in the circuit), there are two accepted methods of alignment. In the first method, each 4008 is isolated and aligned individually. Test tones are sent from the originating end of the circuit to the first 4008 and that module is aligned. The next 4008 is aligned to test tones sent from the site of the first 4008. Subsequent 4008's are aligned in similar fashion. In the second method of alignment, test tones are sent only from the originating end of the circuit and each 4008 is aligned to those tones, beginning with the 4008 closest to the originating end of the circuit. In both methods, alignment of the composite circuit is verified via end-to-end measurements.

Note: A condensed alignment procedure (figure 5) is included to facilitate alignment of the 4008.

alignment — without equalization

3.14 After all options (including gain range) have been selected, insert the 4008 into its mounting, adjust the *gain* potentiometer fully counterclockwise, and apply power. Adjust the gain of the Amplifier as described in paragraph 3.17.

alignment — with equalization

3.15 After all options have been selected, insert the 4008 into its mounting position. Adjust the *HF*, *LF*, and *gain* potentiometers fully counterclockwise and adjust the *LF trim* potentiometer to the approximate midpoint of its range. Apply power and perform the equalization and gain alignment procedures in paragraphs 3.16 through 3.18.

Note: For convenience, the following equalization procedure is written with regard to the module's use in 15kHz applications. In 8kHz applications, the equalization procedure is identical except for the frequencies at which level measurements are made. In 15kHz applications, measurements are made at 15kHz, 10kHz, 1000Hz, and 100Hz. In 8kHz applications, measurements are made at 8kHz, 5kHz, 1000Hz, and 100Hz.

3.16 To align the 4008's equalizer, it is essential that the procedures be followed precisely and in the order presented. Other procedures will result in failure to converge on the desired equalization characteristics.

A. With a properly terminated transmission measuring set (TMS) (receive) connected to the 4008's output jack, request personnel at the originating end of the circuit to send 15kHz test tone at the level specified on their circuit level record (CLR) card. Verify that 15kHz is being sent and record the received level.

B. Request personnel at the originating end to send 10kHz tone at the specified level. Verify the frequency and adjust the *HF* potentiometer clockwise until the 10kHz level is equal to the 15kHz level recorded in step A.

C. Request that the originating end again send 15kHz tone. Verify the frequency and record the level. Request the originating end to send 10kHz and adjust the *HF* potentiometer until the 10kHz level is equal to the new 15kHz level. Repeat this step until the 15kHz and 10kHz levels are equal. Be sure to record each level. (As the *HF* potentiometer is adjusted clockwise, both the 10kHz and 15kHz levels will change. Therefore, several repetitions of adjustment and measurement between 15kHz and 10kHz will probably be required to achieve the desired flat response between the two frequencies.)

D. Request personnel at the originating end to send 1000Hz tone at the specified level. Verify the frequency and adjust the *LF* potentiometer clockwise until the 1000Hz level is equal to the 10kHz level achieved in step C.

E. Request that the originating end send 10kHz tone. Verify the frequency and record the level. If the 10kHz level is different from the 10kHz level achieved in step C, request the originating end send 1000Hz and adjust the *LF* potentiometer until the 1000Hz level is equal to the 10kHz level. Repeat this step until the 1000Hz and 10kHz levels are equal. Be sure to record each level.

F. Request that the originating end send 15kHz tone. Verify the frequency and record the level. Request that the originating end send 10kHz and trim the *HF* potentiometer until the 10kHz level is equal to the 15kHz level measured in this step.

G. Request the originating end to send 1000Hz and adjust the *LF* potentiometer until the 1000Hz level is equal to the 10kHz level achieved in step F. Record this level.

H. Request that the originating end send 100Hz tone. Verify the frequency, and adjust the *LF trim* potentiometer until the 100Hz level is equal to the 1000Hz level recorded in step G.

I. Request the originating end to send 100Hz and 15kHz tones at the specified level. Verify the frequencies and verify that both levels are within ± 1 dB of the 1000Hz level recorded in step G.

continued, page 8

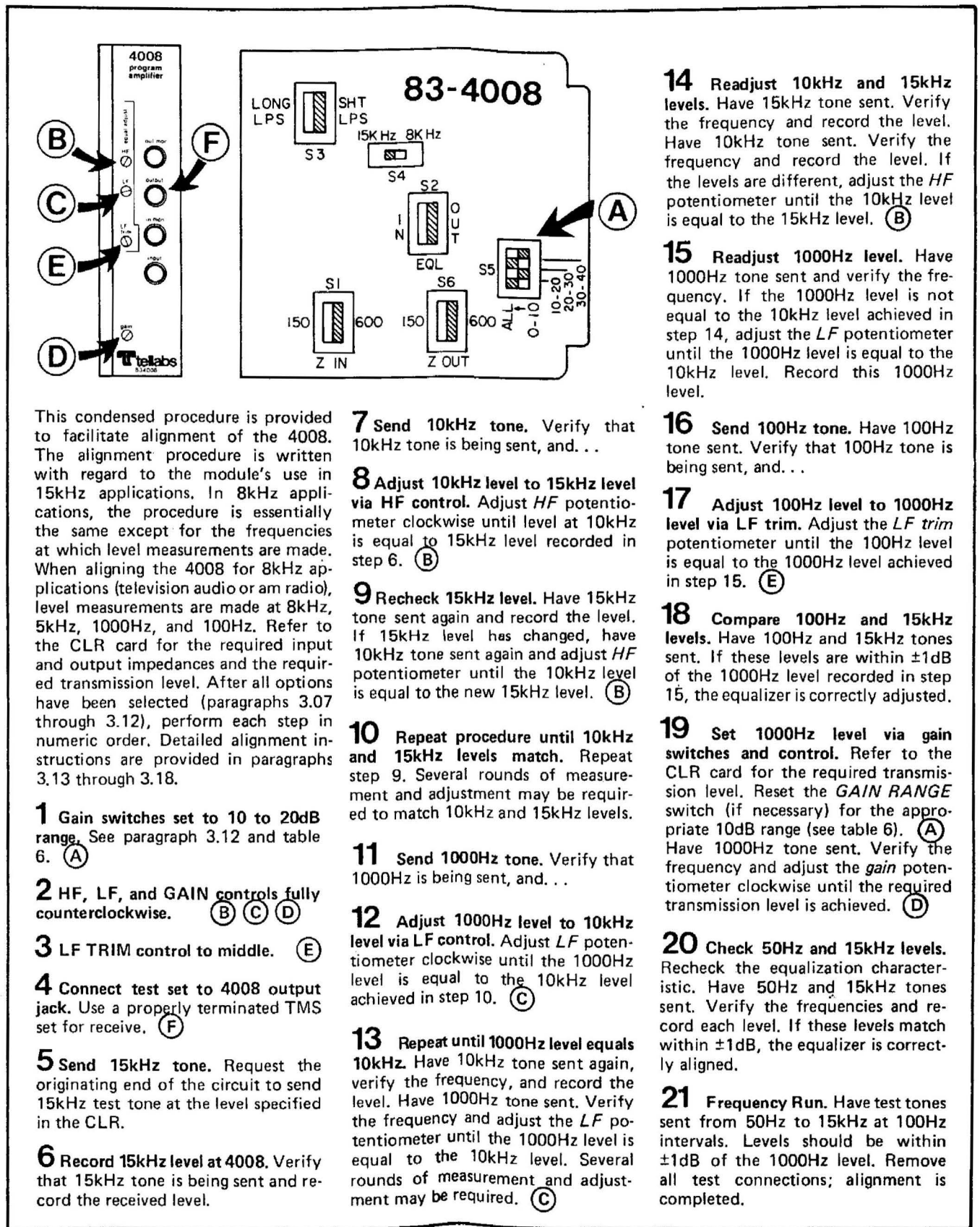

This condensed procedure is provided to facilitate alignment of the 4008. The alignment procedure is written with regard to the module's use in 15kHz applications. In 8kHz applications, the procedure is essentially the same except for the frequencies at which level measurements are made. When aligning the 4008 for 8kHz applications (television audio or am radio), level measurements are made at 8kHz, 5kHz, 1000Hz, and 100Hz. Refer to the CLR card for the required input and output impedances and the required transmission level. After all options have been selected (paragraphs 3.07 through 3.12), perform each step in numeric order. Detailed alignment instructions are provided in paragraphs 3.13 through 3.18.

- 1** Gain switches set to 10 to 20dB range. See paragraph 3.12 and table 6. (A)
- 2** HF, LF, and GAIN controls fully counterclockwise. (B) (C) (D)
- 3** LF TRIM control to middle. (E)
- 4** Connect test set to 4008 output jack. Use a properly terminated TMS set for receive. (F)
- 5** Send 15kHz tone. Request the originating end of the circuit to send 15kHz test tone at the level specified in the CLR.
- 6** Record 15kHz level at 4008. Verify that 15kHz tone is being sent and record the received level.

- 7** Send 10kHz tone. Verify that 10kHz tone is being sent, and...
- 8** Adjust 10kHz level to 15kHz level via HF control. Adjust HF potentiometer clockwise until level at 10kHz is equal to 15kHz level recorded in step 6. (B)
- 9** Recheck 15kHz level. Have 15kHz tone sent again and record the level. If 15kHz level has changed, have 10kHz tone sent again and adjust HF potentiometer until the 10kHz level is equal to the new 15kHz level. (B)
- 10** Repeat procedure until 10kHz and 15kHz levels match. Repeat step 9. Several rounds of measurement and adjustment may be required to match 10kHz and 15kHz levels.
- 11** Send 1000Hz tone. Verify that 1000Hz is being sent, and...
- 12** Adjust 1000Hz level to 10kHz level via LF control. Adjust LF potentiometer clockwise until the 1000Hz level is equal to the 10kHz level achieved in step 10. (C)
- 13** Repeat until 1000Hz level equals 10kHz. Have 10kHz tone sent again, verify the frequency, and record the level. Have 1000Hz tone sent. Verify the frequency and adjust the LF potentiometer until the 1000Hz level is equal to the 10kHz level. Several rounds of measurement and adjustment may be required. (C)

- 14** Readjust 10kHz and 15kHz levels. Have 15kHz tone sent. Verify the frequency and record the level. Have 10kHz tone sent. Verify the frequency and record the level. If the levels are different, adjust the HF potentiometer until the 10kHz level is equal to the 15kHz level. (B)
- 15** Readjust 1000Hz level. Have 1000Hz tone sent and verify the frequency. If the 1000Hz level is not equal to the 10kHz level achieved in step 14, adjust the LF potentiometer until the 1000Hz level is equal to the 10kHz level. Record this 1000Hz level.
- 16** Send 100Hz tone. Have 100Hz tone sent. Verify that 100Hz tone is being sent, and...
- 17** Adjust 100Hz level to 1000Hz level via LF trim. Adjust the LF trim potentiometer until the 100Hz level is equal to the 1000Hz level achieved in step 15. (E)
- 18** Compare 100Hz and 15kHz levels. Have 100Hz and 15kHz tones sent. If these levels are within ± 1 dB of the 1000Hz level recorded in step 15, the equalizer is correctly adjusted.
- 19** Set 1000Hz level via gain switches and control. Refer to the CLR card for the required transmission level. Reset the GAIN RANGE switch (if necessary) for the appropriate 10dB range (see table 6). (A) Have 1000Hz tone sent. Verify the frequency and adjust the gain potentiometer clockwise until the required transmission level is achieved. (D)
- 20** Check 50Hz and 15kHz levels. Recheck the equalization characteristic. Have 50Hz and 15kHz tones sent. Verify the frequencies and record each level. If these levels match within ± 1 dB, the equalizer is correctly aligned.
- 21** Frequency Run. Have test tones sent from 50Hz to 15kHz at 100Hz intervals. Levels should be within ± 1 dB of the 1000Hz level. Remove all test connections; alignment is completed.

figure 5. Condensed alignment procedure

Note: These instructions coincide with the summary of Tellabs' 4008 Videotape Training Program. This and other Tellabs Training Programs are available in 3/4" and 1/2" videotape formats. Contact your Tellabs representative through your training or engineering departments for information about this Program.

3.17 To adjust the gain of the module, refer to the CLR card for the required transmission level and reset the *GAIN RANGE* DIP switch (if necessary) for the appropriate 10dB range. With a properly terminated TMS (receive) connected to the 4008's *output* jack, request that personnel at the originating end of the circuit send 1000Hz tone at the level specified on their CLR card. Verify the frequency and adjust the *gain* control clockwise until the transmission level specified on the CLR card is achieved.

Note: *The active equalizer used in the 4008 is an absorption-type equalizer that functions by reducing insertion gain of the amplifier/equalizer combination below either 8 or 15kHz. Thus, with the equalizer in the circuit, maximum amplifier gain (40dB) is realized only at frequencies near either 8 or 15kHz.*

3.18 After completing the gain adjustment, request that personnel at the originating end of the circuit send 50Hz and 15kHz tones at the level specified on their CLR card. Verify the frequencies and verify that the 50Hz level is within ± 1 dB of the 15kHz level. Make a frequency run, checking levels at 100Hz intervals from 50Hz to 15kHz. Levels should be within ± 1 dB of the 1000Hz level.

4. circuit description

4.01 This circuit description is intended to familiarize you with the 4008 Program Amplifier module for engineering and application purposes only. Attempts to test or troubleshoot the 4008 internally are not recommended. Procedures for recommended testing and troubleshooting in the field are limited to those prescribed in section 7 of this Practice. Please refer to the 4008 block diagram, section 5, as an aid in following this circuit description.

4.02 The input section of the 4008 consists of a wideband input transformer with a split primary winding, and a variable-gain *preamplifier*. The input transformer derives switch-selectable 600 or 150-ohm input impedance and, when optioned for 600 ohms, provides a center tap for derivation of an input simplex lead. The transformer secondary provides input to a variable-gain *preamplifier* that supplies adjustable gain (0 to 10dB) and prevents the equalizer input from affecting the amplifier input impedance.

4.03 With the *EQUAL* switch in the *OUT* position, the *preamplifier* output is connected directly to the input of a *voltage amplifier* whose gain is incremented in 10dB increments from 0 to 40dB in response to switch settings on a four-position DIP switch. A *power amplifier* stage following the *voltage amplifier* stage drives an output transformer with a split primary winding. The output transformer provides switch-selectable 600 ohm or 150 ohm output impedance. An output simplex lead is derived when the transformer is optioned for 600 ohm output impedance.

4.04 When the *EQUAL* switch is set to the *IN*

position, an active *slope equalizer* is inserted between the *preamplifier* and the *voltage amplifier* gain stage. The equalizer response is determined by the location of a pair of complex conjugate poles derived through use of controlled positive feedback around an operational amplifier. Network quality factor (Q), damping factor, and natural resonance are varied to control the response shape.

6. specifications

amplifier section

gain range

0 to 40dB in increments of 10dB, gain continuously adjustable within each 10dB range

frequency response (any gain setting, no equalization)

± 1.0 dB, re 1000Hz, 20Hz to 15kHz

± 0.5 dB, re 1000Hz, 30Hz to 15kHz

gain stability

maximum deviation from gain at 70°F is ± 0.7 dB, -40° to $+140^\circ$ F, 20Hz to 20kHz

maximum output level

+20dBm, 30Hz to 20kHz; +18dBm, 20Hz to 20kHz

maximum input level (input stage overload point)

+10dBm, 30Hz to 20kHz (see note, page 5)

distortion

less than 0.25% THD, 50Hz to 15kHz, measured at +18dB output level;

gain linearity

less than 0.1dB compression, 20Hz to 20kHz, any output level below +18dBm

envelope delay

less than 15 μ s, 200Hz to 20kHz

less than 70 μ s, 100Hz to 20kHz

noise

maximum output noise measured with input terminated, flat weighting, 40Hz to 15kHz, is dependent upon amplifier gain as follows:

gain	8kHz channel	15kHz channel
10dB	5dBm	5dBm
20dB	10	12
30dB	20	22
40dB	20	24

equalizer section

8kHz equalization

± 1.0 dB maximum deviation from flat response, 100Hz to 8kHz, for nonloaded cable with up to 30dB loss differential between 100Hz and 8kHz

15kHz equalization

± 1.0 dB maximum deviation from flat response, 50Hz to 15kHz, for nonloaded cable with up to 30dB loss differential between 50Hz and 15kHz

adjustments (8 and 15kHz equalizers)

high frequency

low frequency

low frequency trim

equalizer response stability

± 0.5 dB maximum variation, -40° to $+140^\circ$ F

specifications continued on page 10

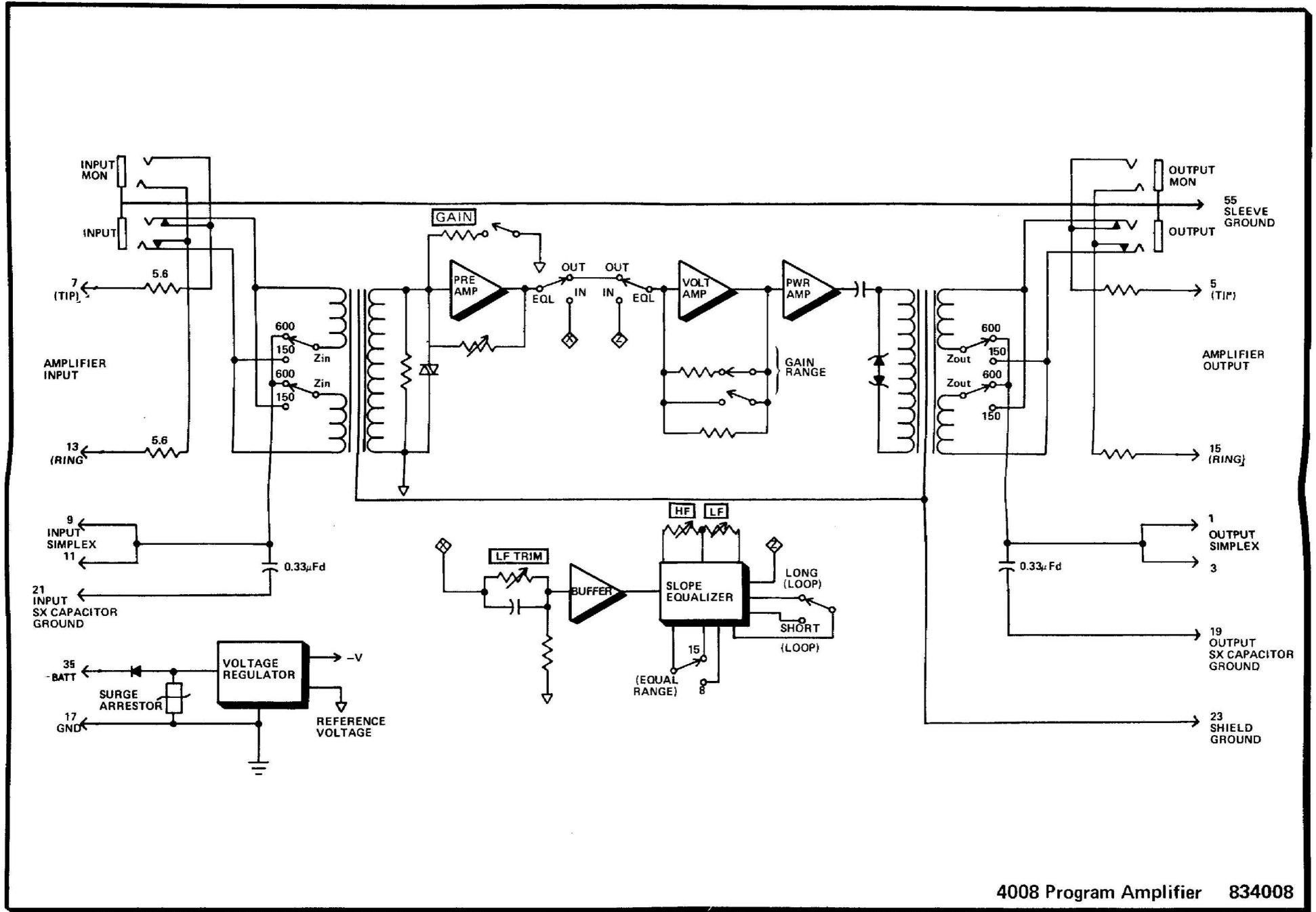

page 6

5. Block Diagram

4008 Program Amplifier 834008

common specifications (with or without equalizer)

input impedance

600 ohms $\pm 5\%$, balanced, 20Hz to 20kHz
150 ohms $\pm 15\%$, balanced, 20Hz to 20kHz

output impedance

600 ohms $\pm 5\%$, balanced, 20Hz to 20kHz
150 ohms $\pm 15\%$, balanced, 20Hz to 20kHz

longitudinal balance (input and output)

greater than 65dB, 20Hz to 20kHz

maximum input voltage

-56Vdc

minimum input voltage (for +20dBm output level)

-23.5Vdc

minimum input voltage (for +18dBm output level)

-20.5Vdc

current (quiescent)

30 to 35mA at 48Vdc

current (+20dBm output level)

45 to 50mA at 48Vdc

jack configuration

input monitor

output monitor

input access

output access

operating environment

-40° to +140° F (-40° to +60° C), humidity to 95% (no condensation)

dimensions

5.58" (14.17cm) high

1.42" (3.61cm) wide

5.96" (15.14cm) deep

weight

13 ounces (368 grams)

mounting

relay rack or apparatus case via one position of a Tellabs

Type 10 Shelf, or one position of a Tellabs Type 248

Mounting Assembly

7. testing and troubleshooting

7.01 The Testing Guide Checklist may be used to assist in the installation, testing or troubleshooting of the 4008 Program Amplifier module. The Testing Guide Checklist is intended as an aid in the localization of trouble to a specific module. If a module is suspected of being defective, a new module should be substituted and the test conduct-

ed again. If the substitute module operates correctly, the original module should be considered defective and returned to Tellabs for repair or replacement. It is strongly recommended that no internal (component level) testing or repairs be attempted on the 4008 module. Unauthorized testing or repairs may void the 4008's warranty.

7.02 If a situation arises that is not covered in the Checklist, contact Tellabs Customer Service at (312) 969-8800, or at your Tellabs Regional Office, for further assistance.

7.03 If a 4008 is diagnosed as defective, the situation may be remedied by either *replacement* or *repair and return*. Because it is the more expedient method, the *replacement* procedure should be followed whenever time is a critical factor (e.g., service outages, etc.).

replacement

7.04 If a defective 4008 is encountered, notify Tellabs via telephone [(312) 969-8800], letter [see below], or twx [910-695-3530]. Notification should include all relevant information, including the 8X4008 part number (from which we can determine the issue of the module in question). Upon notification, we shall ship a replacement 4008 to you. If the warranty period of the defective module has not elapsed, the replacement module will be shipped at no charge. Package the defective 4008 in the replacement module's carton; sign the packing list included with the replacement 4008 and enclose it with the defective module (this is your return authorization); affix the preaddressed label provided with the replacement module to the carton being returned; and ship the equipment prepaid to Tellabs.

repair and return

7.05 Return the defective 4008 Program Amplifier, shipment prepaid, to:

Tellabs Incorporated
4951 Indiana Avenue
Lisle, Illinois 60532

Attn: repair and return dept.

Enclose an explanation of the module's malfunction. Follow your company's standard procedure with respect to administrative paperwork. Tellabs will repair the module and ship it back to you. If the module is in warranty, no invoice will be issued.

testing guide checklist

trouble condition	possible cause (in order of likelihood)
no gain	<ol style="list-style-type: none"> 1) Incorrect setting of <i>GAIN RANGE</i> switch (see paragraph 3.12) <input type="checkbox"/>. 2) Power input polarity <input type="checkbox"/>.
excessive high-frequency roll-off	<ol style="list-style-type: none"> 1) Use of unbalanced source or terminating meter with simplex leads or simplex capacitors grounded <input type="checkbox"/>.
excessive low-frequency loss	<ol style="list-style-type: none"> 1) Improper equalizer adjustment <input type="checkbox"/>. 2) Use of capacitively coupled meter <input type="checkbox"/>.
inability to properly equalize facility	<ol style="list-style-type: none"> 1) Loss in excess of 31dB between highest frequency of interest and 100Hz <input type="checkbox"/>. 2) Incorrect equalization adjustment (see 3.15 to 3.16, or figure 5) <input type="checkbox"/>. 3) Non-uniform cable frequency response, including presence of load coils, buildout capacitors, or impedance compensators <input type="checkbox"/>. 4) Presence of cable bridge-tap, especially at point of connection of <i>repeater</i> <input type="checkbox"/>. 5) Split cable pairs in the program circuit <input type="checkbox"/>.
audible pick up of radio station (Use of a 248RF Assembly, which is required in high RF environments, is assumed.)	<ol style="list-style-type: none"> 1) Unbalanced cable pairs on input side of amplifier <input type="checkbox"/>. 2) Improper power supply grounding <input type="checkbox"/>. 3) Enclosure covers not in place <input type="checkbox"/>. 4) Improper grounding, and lead shielding <input type="checkbox"/>.
excessive 60Hz noise when mounted in 1912 Apparatus Case	<ol style="list-style-type: none"> 1) Unbalanced cable pairs <input type="checkbox"/>. 2) Improper ground of Apparatus Case and dc power supply (if used) <input type="checkbox"/>. 3) Improper connection of List 4 Transformer (power input to the 1912 should be connected to screws 1 and 3 on the List 4 Transformer) <input type="checkbox"/>. 4) Low power voltage (minimum power voltage is 23Vdc or 26Vac between terminals 10 and 11 on the 1912 barrier strip) <input type="checkbox"/>.
excessive 60Hz noise — remote power location	<ol style="list-style-type: none"> 1) Unbalanced cable pairs <input type="checkbox"/>. 2) Failure to filter power feed input to 4008 (see paragraph 2.13) <input type="checkbox"/>. 3) Improper arrangement of transformer simplex capacitor grounds and transformer shield grounds <input type="checkbox"/>. 4) Failure to locally ground jack sleeves (pin 55) <input type="checkbox"/>. <p><i>Note: Effects of cable unbalance can be determined by inserting a terminating plug into the INPUT jack and measuring the noise at the OUTPUT jack. This isolates the amplifier from the cable (in both directions, if appropriate), making possible the measurement of amplifier noise without introduction of noise from the cable.</i></p>
distortion at amplifier output	<ol style="list-style-type: none"> 1) Excessive output signal level <input type="checkbox"/>. 2) Input signal level too high, especially at low frequencies (input signals above +10dBm may overload first equalizer stage) (see note, page 5) <input type="checkbox"/>.

Tellabs Incorporated
 4951 Indiana Avenue, Lisle, Illinois 60532
 telephone (312) 969-8800 twx 910-695-3530

Addendum: 4008 Program Amplifier

1. General

- 1.01 This addendum to Practice Section 834008, revision G (dated September 1979), is being issued to correct the *input impedance* and the *output impedance* on page 10, replace the existing text with the following corrected text:

input impedance

600 ohms $\pm 15\%$, balanced, 20Hz to 20kHz

150 ohms $\pm 15\%$, balanced, 20Hz to 20kHz

output impedance

600 ohms $\pm 15\%$, balanced, 20Hz to 20kHz

150 ohms $\pm 15\%$, balanced, 20Hz to 20kHz