

1. GENERAL .....	1
2. TEST SET ARRANGEMENT .....	2
Controls .....	2
Indicators .....	3
Test Jacks .....	3
3. TEST CORDS .....	4
4. PREPARATION .....	4
5. TEST PROCEDURES .....	5
Preliminary .....	5
Step-By-Step Tests .....	6
Method for Performing Tests .....	7
A Relay Current Test .....	7
B Relay Release Test .....	8
C Relay Release & Rotary Speed Test (Selectors) .....	8
Polarity Test of Trunks from Selector Levels .....	9
Digit Absorbing Tests .....	10
Loop Pulsing Tests .....	10
Leak Pulsing Tests .....	11
Simplex Pulsing Tests .....	12
Magnet Tests .....	12
External Voltmeter and Milliammeter Tests .....	13
Transmission and Noise Measuring Access .....	14
Other Relay Release Time Tests .....	14
6. MAINTENANCE .....	15
Field Calibration Check .....	15
Milliammeter Check .....	15
Voltmeter Check .....	16
Output Pulsing Check .....	17
7. REPAIR .....	18

**1. GENERAL**

1.01 This Section is issued to provide the description and instructions for the operation and use of the CMC 708 QUIK CHEK® -II TEST SET (see Figure 1). This Test Set is used for routing PBX, CDO and large SXS central offices to determine the necessary adjustments and/or repairs for the equipment.

1.02 This Section is revised to add a field calibration check procedure and to incorporate the information from the Addendum CMC 0708, Issue 1 (March, 1979) into the Practice. Due to the extent of changes, change indicators are not used.



**Figure 1 CMC 708 Quik Chek® -II Test Set**

1.03 The Quik Chek-II has several features which simplify its use; a five-digit loop and simplex auto dialer; a digital panel meter with a full-scale accuracy of  $\pm 0.2\%$  presents large easily read digits; an amplified push-to-talk circuit; and long life light-emitting diodes (LED's) for display of circuit polarity and continuity.

1.04 The Quik Chek-II is used to perform the following tests:

- (a) Pulsing
  - (1) Loop 1400 ohm and 1200 ohm
  - (2) Leak A and B
  - (3) Simplex loop (77% Brk.) and leak (42% Brk.)
  - (4) Pulse Rate: 12 pps
- (b) Timing
  - (1) B relay release
  - (2) C relay release and rotary speed
  - (3) Relay (other than B and C) release
- (c) Magnet Test
  - (1) Loop (20% BK)
  - (2) Leak (67% BK)
- (d) "A" Relay Current Test
  - (1) Test Values
  - (2) Readjust Values

**Section CMC 0708**  
**Issue D**

- (e) External dc Voltage Measurements
- (f) External dc Milliampere Measurements
- (g) Polarity and Monitor
  - (1) Loop Polarity
  - (2) Sleeve Polarity
  - (3) Simplex Continuity
  - (4) Push-to-Talk
- (h) Transmission and Noise Measuring Test Access (900 ohm impedance)
- (i) Digit Absorbing Features

C RLS MS ROT SPD	C relay release Timing in milli-seconds and Rotary Speed Test (Loop or SX Mode)
POLARITY & MON	Polarity Test, Push-to-Talk and Monitor (Loop or SX Mode)
LP 1400	Loop Pulsing Test, 1400 ohms line resistance at 68.5% break
LK A	Leak Pulsing Test Type A 60.5% break
LP 1200	Loop Pulsing Test, 1200 ohm line resistance at 68.5% break
LK B	Leak Pulsing Test Type B 60.5% break
SX LP	Simplex Loop Pulsing Test at 77% break (Loop or SX Mode)
SX LK	Simplex Leak Pulsing Test at 42% break (Loop or SX Mode)
MAG LP	Magnet Loop Pulsing Test at 67% break (Loop or SX Mode)
MAG LK	Magnet Leak Pulsing Test at 20% break (Loop or SX Mode)
CURRENT TEST	Provides all static current testing described in sub-paragraph (c) (Loop or SX Mode)

1.05 The test set operator can monitor wiper and switch noise, observe tones and announcements and talk over circuits when required.

1.06 The Test Set requires no warm-up time. It can be used strapped to a ladder or placed on a cart.

**2. TEST SET ARRANGEMENT**

2.01 The following controls, indicators and jacks are located on the face of the Quik Chek-II Test Set (see Figure 1).

**Controls**

2.02 The controls described below are used to prepare the Test Set to perform the desired test functions:

- (a) DIGIT SELECT Switch - Five Station lever switch; each station has 12 positions designated 0 through 9, X (skip) and S (stop) respectively. Selects the digit(s) to be out-pulsed by the auto dialer.
- (b) TEST SELECTOR Switch - Rotary Switch provides for the following test settings. All pulsing is at 12 pps  $\pm$  1 pulse. Percent Break values are accurate to  $\pm$  0.5% (see Figure 8 for Brush Recorder charts of the output pulsing in the various switch settings).

- (c) CURRENT TEST Controls - Current test functions may be performed in SX (simplex) or Loop Mode. The Test Set mode is selected by operation of the MODE-SX/LOOP switch to the proper position (see sub-paragraph e).
  - (1) ENABLE - LOCK ON and MOMENTARY switches (illuminated while operated).
    - LOCK ON - (On-off push button) locks Test Set in current Test Mode for adjusting current flow value.
    - MOMENTARY - (Momentary Push-button) applies current flow value momentarily to relay under test.

OPR - Selects the current value adjusted by the OPERATE potentiometer.

SOAK - Eliminates the series potentiometer adjustments and selects a fixed soak current value.

NON-OPR - Selects the current value adjusted by the NON-OPERATE potentiometer.

- (3) OPERATE/NON-OPERATE Potentiometers (Equipped with Positive Lock).

OPERATE Control - Adjustment for A relay operate current flow value.

NON-OPERATE Control - Adjustment for A relay non-operate current flow value.

- (d) TEST - RELEASE and START switches (illuminated while operated).

START - (Momentary Push-button) starts auto dialer for all dialing or repeated tests.

RELEASE - (Momentary Push-button) opens the loop (on hook). Stops the auto dialer and all repeated tests.

- (e) MODE-SX/LOOP Switch (2-position) -

SX selects simplex operation mode of Test Set in TEST SELECTOR switch positions SX-LP, SX-LK, B RLS MS, C RLS MS ROT SPD and POLARITY & MON

LOOP selects loop operation mode of Test Set in all TEST SELECTOR switch positions.

- (f) PUSH-TO-TALK Switch - Push-button switch connects the speaker as a microphone to converse over the test circuit.

- (g) VOLUME Control - Adjust volume of the monitor amplifier in Test Set.

- (h) RANGE (10, 100 & 1000) Switches - Push-button switches select the operating current range or voltage range of the Test Set meter.

*NOTE: The dc current measuring and adjusting capability ranges are:*

*0 to 19.99 mA measurable to 0.01 mA (RANGE Switch 10)*

*0 to 199.9 mA measurable to 0.1 mA (RANGE Switch 100)*

*0 to 1999 mA measurable to 1.0 mA (RANGE Switch 1000)*

*WARNING: To avoid internal damage to the Test Set, current flow through the OPERATE and NON-OPERATE potentiometers should be limited to 250 mA and voltages greater than 300V dc should not be measured with the Test Set.*

- (i) EXTERNAL (VOLTS and MA) Switches - Select operating mode of Test Set when used as a dc voltmeter or dc milliammeter. The Test Set will NOT measure ac mA or ac voltage.

#### Indicators

2.03 The indicators on the Test Set are as follows:

- (a) LOOP POLARITY: STR LED for straight line polarity and REV LED for reverse line polarity. (Not used in Simplex Testing).
- (b) SP/SL - E/EC: BATT for - 50V potential on SP/SL or E/EC lead and GND for ground (+) potential on SP/SL or E/EC lead.
- (c) SX CONTINUITY: TIP for continuity through the Tip-lead and RING for continuity through the Ring lead of Simplex Circuits.

2.04 The Panel Meter is a 3-1/2 digit digital meter with overrange indicator. Accuracy is  $\pm 0.2\%$  of full-scale range selected.

*NOTE: Overage is indicated by a flashing digital display on the meter.*

#### Test Jacks

2.05 The Test Set is equipped with the following Telephone Company type test jacks:

- (a) BATT jack (310 type) - Connects C.O. battery and ground to the Test Set.

**Section CMC 0708  
Issue D**

- (b) TRANSMISSION jack (310 type) - Connects a transmission or noise measuring set to the Test Set for level or noise measurements on the test circuit (900 ohm input impedance).
- (c) MAG TEST & C RLS jack (310 type) - Connects the magnets (vertical or rotary) of a two-motion switch to the Test Set for a magnet test. Connects a ground return to the Test Set for C release timing.
- (d) TEST jack (310 type) - Connects the two-motion switch to be tested to the Test Set.

- (c) CMC 0076 (3W4A) Test Cord - A three-conductor cord, 6-ft. long, one end equipped with a 310 plug and the other end equipped with three 360 tools.

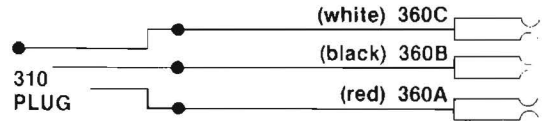

- (d) 419A Connecting Tools (3) - Plug into 360 Tools to connect Test Set to equipment.
- (e) KS6278 Connecting Tools (3) - Plug into 360 Tools to connect Test Set to equipment.

**3. TEST CORDS**

3.01 The following test cords and connecting tools are furnished with the Quik Chek-II Test Set:

- (a) CMC 0073 (2P9A) Test Cord - A two-conductor cord, 9-ft. long, equipped with a 310 plug on each end. Used for a power cord when the office is equipped with power jacks.



For central offices and dial PBX's equipped with battery and ground clip-on terminals: 2W12A Test Cord - A two-conductor cord, 9-ft. long, equipped with a 310 plug on one end and alligator clips on the other end.



- (b) CMC 0078 (3P35A Modified) Test Cord - A three-conductor cord, 9-ft. long, one end equipped with a 310 plug and the other with a 240H plug, modified as follows:

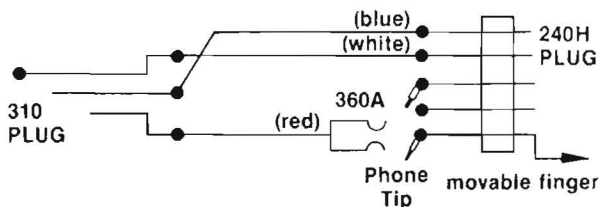

3.02 The following Test Cord is required when using the Quik Chek-II with Stromberg XY equipment. However, the XD Release and Y speed Timing Test cannot be performed. Order the Test Cord separately.

- (a) Test Cord: Assembly CMC 0080 - A three-conductor cord, 9-ft. long, one end equipped with a 310 plug and the other end with an SC-63 plug.



**4. PREPARATION**

4.01 Make the following connections for all tests with the Quik Chek-II Test Set:

*NOTE: Switch covers should not be removed except for C relay actual release time test and magnet test or for readjusting the relays.*

- (a) Insert the 310 plug of the power cord into the BATT jack on the face of the Quik Chek and connect the other end to C.O. battery supply (-50V dc nominal; minimum -47V to maximum -54V).

*NOTE: When connecting the Test Set power cord, connect to the C.O. battery supply LAST. When disconnecting the equipment, disconnect the C.O. battery supply FIRST.*

- (b) Insert the 310 plug of the 3P35A test cord into the TEST jack of the Quik Chek-II and the 240H plug into the switch test jack.

- (c) Insert a CMC 106-608 Dummy Plug (Phenolic) or equivalent into the TRANSMISSION test jack for ALL testing except transmission level or noise measurements (see Figure 2). The Dummy Plug is furnished with the Test Set.

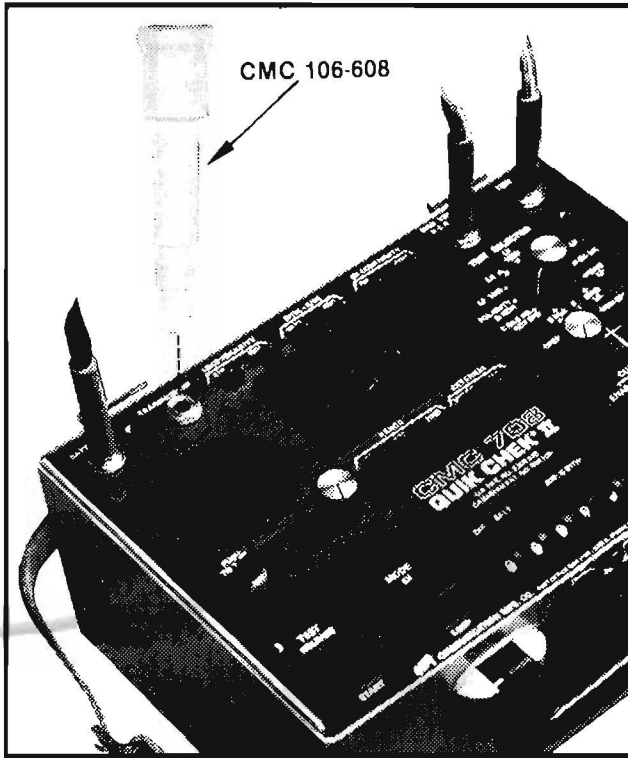

Figure 2 Phenolic Dummy Plug and Location of Transmission Test Jack.

4.02 Make the following additional connection to verify C relay release time. This test does not need to be performed except in case of a failure in the C relay release and rotary speed test.

- (a) Insert the 3W4A Test Cord 310 plug into the Quik Chek MAG TEST & C RLS Test Jack and connect the White (T) lead to the rotary interrupter spring having interrupted access to the rotary magnet (see Figure 3).
- (b) Be sure that the 3P35A cord red lead is disconnected from the 240H plug.

4.03 **CAUTION:** Due to a mercury-wetted pulsing relay, used for precise pulsing, the Quik Chek-II Test Set **MUST** be placed in a horizontal position with the faceplate up while in use. Variations of more than 30° tilt from the horizontal position will cause pulse distortion.

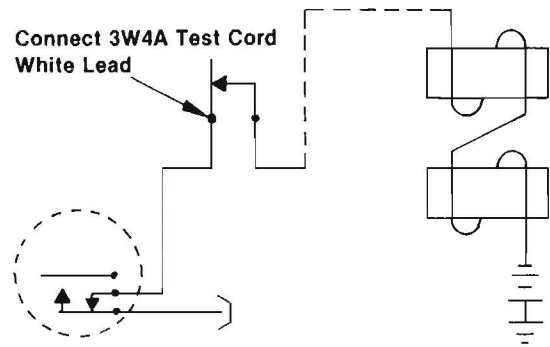

Figure 3 Schematic of Typical Selector Rotary Magnet Operating Circuit Showing Connection to Interrupter Spring (Paragraph 4.02)

## 5. TEST PROCEDURES

### Preliminary

- 5.01 Make the Test Set connections as described in Paragraph 4.01.
- 5.02 Set the TEST SELECTOR Switch to the CURRENT TEST Position.
- 5.03 Operate the MODE switch to the LP position (for Loop Pulsed Switches) or SX position (for Simplex Pulsed Switches) according to the type of switch to be tested.
- 5.04 Unlock the OPERATE and NON-OPERATE controls and adjust them to the mid-position. Depress the 100 RANGE switch.
- 5.05 Operate the CURRENT TEST VALUE switch to the SOAK position. Momentarily depress the ENABLE - MOMENTARY switch.
- 5.06 Operate the VALUE switch to the OPR position. Depress the ENABLE-LOCK ON switch. Adjust the OPERATE control to indicate the Test Operate Value (15.1), Readjust Operate Value (14.8) or other desired value on the Digital Meter. Lock the OPERATE control by rotating the locking ring in the direction of the arrows (clockwise). Depress the ENABLE-LOCK ON switch.
- 5.07 Operate the VALUE switch to the NON-OPR position. Depress the ENABLE-LOCK ON switch. Adjust the NON-OPERATE control to indicate the Test Non-Operate Value (14.4), Readjust Non-operate Value (13.9) or other desired value on the Digital Meter. Lock the NON-OPERATE control by rotating the locking ring in the direction of the arrows (clockwise). Depress the ENABLE-LOCK ON switch.

**Section CMC 0708**  
**Issue D**

5.08 If a subscriber is encountered during any test through misdialing or stopping on a busy switch, the Quik Chek-II operator may converse with him by depressing the PUSH-TO-TALK switch.

*NOTE: The PUSH-TO-TALK switch is not effective in B and C TIMING or CURRENT TEST modes.*

**Step-By-Step Tests**

5.09 The following paragraphs cover the tests which may be made with the Quik Chek-II Test Set on Step-by-Step switches in all types of Step-by-Step offices, including CDO's, Centrex and PBX's.

*NOTE: In offices using a 52V power supply, the voltage must be reduced to 50V prior to performing Loop or Leak pulsing tests for accurate results.*

5.10 The Tests are as follows:

- (a) A RELAY CURRENT TEST: This is a Quik Chek of the A RELAY using the Current Flow TEST values specified in the circuit requirements (Loop or SX Mode).
- (b) B RELAY RELEASE: This is a Quik Chek of the B RELAY releasing time. The actual B relay release time is displayed on the meter (Loop or SX Mode).
- (c) C RELAY RELEASE and ROTARY SPEED-SELECTORS: This is a Quik Chek of the C RELAY releasing time, cut in, and rotary stepping. Actual C relay release time can be displayed on the meter (Loop or SX Mode).
- (d) POLARITY: This is a Quik Chek of the continuity and polarity of switches and selector level trunks (Loop or SX Mode).

- (e) DIGIT ABSORBING: This is a Quik Chek of the digit absorbing features of selectors (Loop or SX Mode).
- (f) LOOP PULSING: This is a Quik Chek method of making loop pulsing tests on selectors and connectors.
- (g) LEAK PULSING: This is a Quik Chek method of making leak pulsing tests on selectors and connectors.
- (h) SIMPLEX PULSING: This is a Quik Chek of the pulsing and continuity of simplex switches and selector level trunks.
- (i) MAGNET: This is a Quik Chek of the vertical and/or rotary magnets of selectors and connectors.
- (j) VOLT/MILLIAMP: This is a Quik Chek of dc voltage or dc milliamperes.
- (k) OTHER RELAY RELEASE: This is a Quik Chek of the release time of relays other than B and C relays. Actual relay release time is displayed on the meter.

5.11 If it is found necessary to talk on a connection, the PUSH-TO-TALK switch is held depressed. The speaker is used as a microphone while talking. The PUSH-TO-TALK switch is non-locking.

5.12 Local procedures should apply in busying out switches, trunks, etc.

5.13 Records of troubles found and other reports should be made out as required locally.

Method for performing Tests:

STEP	ACTION	VERIFICATION
<b>A RELAY CURRENT TEST</b>		
1	Prepare the Quik Chek-II as described in Paragraphs 4.01 and 5.01 through 5.08.	None
2	Set the TEST SELECTOR switch to the CURRENT TEST position. Insert the Test Cord 240H plug into the test jack of the switch under test.	None
3	With the OPR and NON-OPR settings adjusted as in Paragraphs 5.02 through 5.07, operate the VALUE switch to the SOAK position and momentarily depress the ENABLE-MOMENTARY switch.	The A relay operates when the ENABLE switch is in the MOMENTARY position and releases when the ENABLE switch returns to OFF position.
	Operate the VALUE switch to the OPR position and momentarily depress the ENABLE-MOMENTARY switch.	
4	Operate the VALUE switch to the SOAK position and momentarily depress the ENABLE-MOMENTARY switch.	The A relay does not operate when the VALUE switch is operated to the NON OPR position.
	Operate the VALUE switch to the NON OPR position and momentarily depress the ENABLE-MOMENTARY switch.	
5	Remove the 240H plug from the test jack of the switch and insert it into the next switch to be tested; or if preferred, make other desired tests on the same switch.	None
6	Repeat Steps 2 through 5 until all switches have been tested.	Same as Steps 2 through 5
7	Remove the 240H plug from the last switch tested.	None

Section CMC 0708  
Issue D

STEP	ACTION	VERIFICATION
<b>B RELAY RELEASE TEST</b>		
1	Connect the Test Set as described in Paragraph 4.01.	None
	Connect the 3P35A cord red lead to the 240 plug sleeve(s) spring.	
2	Set the TEST SELECTOR switch to the B RLS-MS position.	<p>The Test Set seizes the switch for 250 ms then releases, starting the timing period. The actual release time of the B Relay is displayed in milliseconds on the Digital Panel Meter. The test is automatically repeated every 1583 ms.</p> <p><i>NOTE: If the Test Set is inadvertently left in either the 10 or 100 range, a decimal point will appear in the meter display. In this case, disregard the decimal and read the three digits as whole milliseconds.</i></p>
	Depress the RANGE-1000 switch. momentarily depress the TEST-START switch.	
3	Momentarily depress the TEST-RELEASE switch.	The switch under test releases and the Test Set stops pulsing.
4	Repeat Steps 1 through 3 until all switches have been tested.	Same as Steps 1 through 3.
5	Remove the 240H plug from the last switch tested.	

**C RELAY RELEASE & ROTARY SPEED TEST (SELECTORS)**

1	<p>Connect the Test Set as described in Paragraph 4.01.</p> <p><i>NOTE: Be sure that the red lead is connected to the movable finger of the 240H plug and the finger rests firmly against the C (sleeve) wiper cord terminal.</i></p>	None
2	Set the TEST SELECTOR switch to the C RLS-MS & ROT SPD position.	
	Momentarily depress the TEST-START switch.	<p>The Test Set seizes the switch for 250 ms, opens the circuit for 83 ms and again seizes the switch for 375 ms then opens the circuit.</p> <p>The switch steps to the first level and rotates to 9th or 10th rotary step and releases. The test is repeated every 1583 ms.</p>
	To verify the actual C relay release time, make the additional connection described in Paragraph 4.02. Depress the RANGE-1000 switch. (This test is normally used only if C relay release and rotary speed test fails to meet requirements.)	The switch steps to the first level and rotates to the first idle trunk. The actual C relay release time in milliseconds is displayed on the digital meter ( <i>see Note in B Relay Release Test, Step 2, Verification</i> ).

STEP	ACTION	VERIFICATION
<b>C RELAY RELEASE &amp; ROTARY SPEED TEST (SELECTORS) Continued</b>		
3	Momentarily depress the TEST-RELEASE switch.	The switch under test releases and the Test Set stops pulsing.
4	Repeat Steps 1 through 3 until all switches have been tested.	Same as Steps 1 through 3.
5	Remove the 240H plug from the last switch tested. Remove the 310 plug from the Test Set MAG TEST & C RLS jack if used.	None
<b>POLARITY TEST OF TRUNKS FROM SELECTOR LEVELS</b>		
1	Connect the Test Set as described in Paragraph 4.01.	None
2	Set the TEST SELECTOR switch to the POLARITY & MON position.	None
3	Operate the DIGIT SELECT lever switches to select the digit for the bank level to be tested. (When setting only one digit on the DIGIT SELECT switches, set the left lever switch to the desired digit and the remainder of the switches to the X position). <i>NOTE: Always set the left-most switch to a digit (0 through 9).</i>	None
4	Momentarily depress the TEST-START switch.	The switch under test steps up and cuts in on level indicated by the DIGIT SELECT switch.
	"Flip" the switch across the bank level.	On Loop Pulsed switches, LOOP POLARITY - STR & REV LED's light to indicate polarity of each trunk in turn.  On Simplex pulsed switches, SX CONTINUITY - TIP and RING LED's light to indicate circuit continuity.
5	Momentarily depress the TEST-RELEASE switch.	The switch under test restores to normal.
6	Repeat Steps 3, 4 and 5 until all levels have been tested.	Same as Steps 3, 4 and 5.
7	Remove the 240H plug and repeat Steps 1, 3, 4, 5 and 6 until all trunks in all shelves have been tested.	Same as Steps 1, 3, 4, 5 and 6.
8	Remove the 240H plug from the last switch tested.	

STEP	ACTION	VERIFICATION
<b>DIGIT ABSORBING TEST</b>		
1	Prepare the Test Set as described in Steps 1 through 3 of the POLARITY TEST OF TRUNKS FROM SELECTOR LEVELS.	None
2	Momentarily depress the TEST-START switch.	The switch under test steps to the level indicated by the DIGIT SELECT switch and: <ol style="list-style-type: none"> <li>1. If the digit is absorbed - the switch releases.</li> <li>2. If unlocked - the switch cuts in to first idle trunk.</li> </ol>
3	Repeat Steps 1 and 2 until all digit absorbing features on all levels have been tested.	Same as Steps 1 and 2.
4	Momentarily depress the TEST-RELEASE switch.	The Switch restores to normal.
	Remove the 240H plug from the switch under test.	
5	Repeat Steps 1 through 4 until all switches have been tested.	Same as Steps 1 through 4.
6	Remove the 240H plug from the switch under test.	None

**LOOP PULSING TEST**

1	Connect the Test Set as described in Paragraph 4.01.  <i>NOTE: In offices using 52V power supply, the voltage MUST be reduced to 50V prior to performing Pulsing Tests for accurate results.</i>	None
2	Set the TEST SELECTOR switch to the required Loop position (LP 1400 or LP 1200).	None

STEP	ACTION	VERIFICATION
<b>LOOP PULSING TEST Continued</b>		
3	<p>Select the bank level to be dialed (normally 9). The Auto Dialer is programmed via the five DIGIT SELECT lever switches. Each lever switch has 12 positions: 0-9, X (skip) and S (stop). The desired digits are set on the switches starting with the left-most switch. The switches not required are set in the X position.</p> <p><i>NOTE: If it is desired to dial the switch train beyond the switch under test, the digits to be dialed are preset on the DIGIT SELECT lever switches. Dialing can be stopped after any digit by pre-operating a succeeding lever switch to the S (stop) position. As an example, the number 234 may be programmed to stop after each digit by operating the first, third and fifth lever switches to positions 2, 3 and 4, respectively, and the second and fourth lever switches to position S (stop). To restart auto-dialing, momentarily depress the TEST-START switch.</i></p>	None
4	<p>Momentarily depress the TEST-START switch.</p>	The preset digit(s) is outputted each time the TEST-START switch is depressed.
	<p><i>NOTE: On some switches it is necessary to separate contacts 5 &amp; 6 of the test jack assembly with an orange stick in order to perform pulsing tests.</i></p>	Observe that the switch under test steps smoothly to the correct level and rotates to the first idle trunk.
5	<p>Momentarily depress the TEST-RELEASE switch. Remove the 240H plug from the switch under test.</p>	The switch under test restores to normal.
6	<p>Repeat Steps 1, 4 and 5 on next switch until all switches are tested.</p>	Same as Steps 1, 4 and 5.

**LEAK PULSING TESTS**

1	<p>Set the TEST SELECTOR switch to the required Leak position (LK A or LK B) otherwise the procedure is the same as the LOOP PULSING TESTS.</p>	Same as in the LOOP PULSING TEST.
---	---	-----------------------------------

**SIMPLEX PULSING TESTS**

1	Connect the Test Set as described in Paragraph 4.01.	None
	<p><i>NOTE: In offices using 52V power supplies, the voltage must be reduced to 50V prior to performing pulsing tests for accurate results.</i></p> <p>Connect a ground cord from a convenient ground point to the sleeve of the CMC 0078 Test Cord 240 plug to furnish a holding ground forward on the circuit. Use a single conductor cord with an alligator clip on one end and a 360 Tool on the other.</p>	
2	Operate the MODE-SX/LOOP switch to the SX position and the TEST SELECTOR switch to the required simplex position (SX-LP or SX-LK).	None
3	Select the bank level to be dialed (normally 9) as in Step 3 of LOOP PULSING TEST.	None
4	Momentarily depress the TEST-START switch.	The preset digit(s) is out-pulsed each time the TEST-START switch is depressed.
		In the SX-LP mode, the switch steps to the correct level and rotates to the first idle trunk. (The switch may not step smoothly).
		In the SX-LK mode, the switch steps smoothly to the correct level and rotates to the first idle trunk.
5	Remove the 240H plug from the switch under test. Momentarily depress the TEST-RELEASE switch.	The switch under test restores to normal and the Test Set stops pulsing. The auto dialer is reset.

**MAGNET TESTS**

1	Connect the Test Set as described in Paragraph 4.01 ( <i>see Loop Pulsing Test, Step 1 NOTE</i> ).	None
	Insert the 3W4A test cord 310 plug into the Test Set MAG TEST & C RLS jack.	

STEP	ACTION	VERIFICATION
<b>MAGNET TESTS Continued</b>		
2	Connect the 3W4A test cord Ring (Black) lead to the B relay spring which is connected to the vertical magnet (normally spring 3).	None
3	Operate the TEST SELECTOR switch to the MAG LK position and the MODE switch to the LOOP position. Momentarily depress the TEST-START switch.	The switch under test pulses 9 steps vertical.
4	If a retest is desired on the same switch, momentarily depress the Test Set TEST-RELEASE switch. Wait approximately one second for Test Set to re-seize the switch. Momentarily depress the TEST-START switch.	The switch under test pulses 9 steps each time the TEST-START switch is depressed.
5	Disconnect the test cord from the B relay spring.	Switch under test restores to normal.

**EXTERNAL VOLTMETER AND MILLIAMMETER TESTS**

1	Connect C.O. battery to the Test Set as in Paragraph 4.01 (a).	None
	Insert the 3W4A Test Cord 310 plug into the Test Set TEST jack.	
2	<p>Depress the appropriate RANGE switch (10,100 or 1000) and the EXTERNAL - VOLTS or EXTERNAL - MA according to the required operating mode.</p> <p>NOTE: As a safety feature, the EXTERNAL VOLTS and MA switches are the on-off type and are interlocked so that both switches cannot be operated at the same time.</p>	None
3	<p>Connect the 3W4A Test Cord connecting tools to the circuit to be tested (white cord to positive side and black cord to negative side).</p> <p>NOTE: See Paragraph 2.02 (h).</p>	The voltage or milliampere value is indicated on the Test Set Digital Meter. If the Meter display is preceded by a negative (-) symbol, the polarity of the test leads is reversed.
4	After testing is completed, disconnect the Test Set and restore all equipment to normal.	None

STEP	ACTION	VERIFICATION
<b>TRANSMISSION AND NOISE MEASURING ACCESS</b>		
1	<p>Transmission or noise measuring tests can be performed in conjunction with other tests. A transmission measuring set (TMS) or noise measuring set (NMS) is patched to the circuit under test by connecting the input jack of the TMS or NMS to the TRANSMISSION jack of the Quik Chek-II Test Set with a 3P7A Test Cord. This connects TMS or NMS input to the tip and ring of the TEST jack.</p> <p><i>NOTE: The TRANSMISSION jack has a 900 ohm impedance.</i></p>	<p>Transmission level or noise is indicated on TMS or NMS when the trunk is seized during normal test.</p>
<b>OTHER RELAY RELEASE TIME TESTS</b>		
1	<p>Connect C.O. battery to the Test Set as in Paragraph 4.01 (a).</p>	<p>None</p>
2	<p>Insert a 3W4A or equivalent Test Cord (3-conductor cord equipped with 310 plug one end and three 360 tools on other end) into the Test Set TEST jack.</p> <p>Connect the Test Cord 360 Tools to the relay to be timed as shown in Figure 4.</p>	<p>None</p>
3	<p>Set the TEST SELECTOR switch to the B RLS - MS position.</p> <p>Depress the RANGE-1000 switch. Momentarily depress the TEST-START switch.</p>	<p>The Test Set seizes the relay for 250 ms then releases, starting the timing period. The actual release time of the relay is displayed in milliseconds on the Digital Panel Meter. The test is automatically repeated every 1583 ms until released.</p> <p><i>NOTE: If the Test Set is inadvertently left in either the 10 or 100 range, a decimal point will appear in the meter display. In this case, disregard the decimal and read the three digits as whole milliseconds.</i></p>
4	<p>Momentarily depress the TEST-RELEASE switch.</p>	<p>The relay under test is released and the Test Set stops pulsing.</p>
5	<p>Remove all test connections and restore all equipment to normal.</p>	

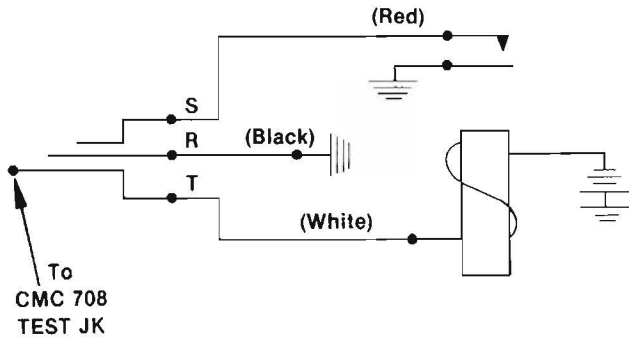

NOTE: Polarity may be reversed through relay coil (Tip and Ring Leads).

Figure 4 Schematic of Connections for checking Release Time for Relays other than B or C Function Relays

## 6. MAINTENANCE

6.01 There is no maintenance to be performed on the Quik Chek-II by the field forces.

6.02 Should the Test Set be suspected of a malfunction or if it has been exposed to exceptionally rough handling, a field calibration check may be performed as described in Paragraphs 6.03 through 6.29. If the calibration check indicates problems do exist, the Test Set should be returned to CMC for complete routine maintenance and repair.

### Field Calibration Check

6.03 The test equipment required to perform the calibration check is as follows:

- CMC 7350 Current Flow Test Set or equivalent.
- Brush Recorder, Mark 220 or equivalent.
- Test cords as required for connecting the test equipment.

### Milliammeter Check

6.04 Prepare the CMC 7350 Current Flow Test Set as follows (see Figure 5):

- Connect 50V central office battery supply to the BATT jack of the Test Set with the 2P9A or 2W12A Power Cord.
- Depress the BATT function switch, the MA mode switch and the 100 range switch.

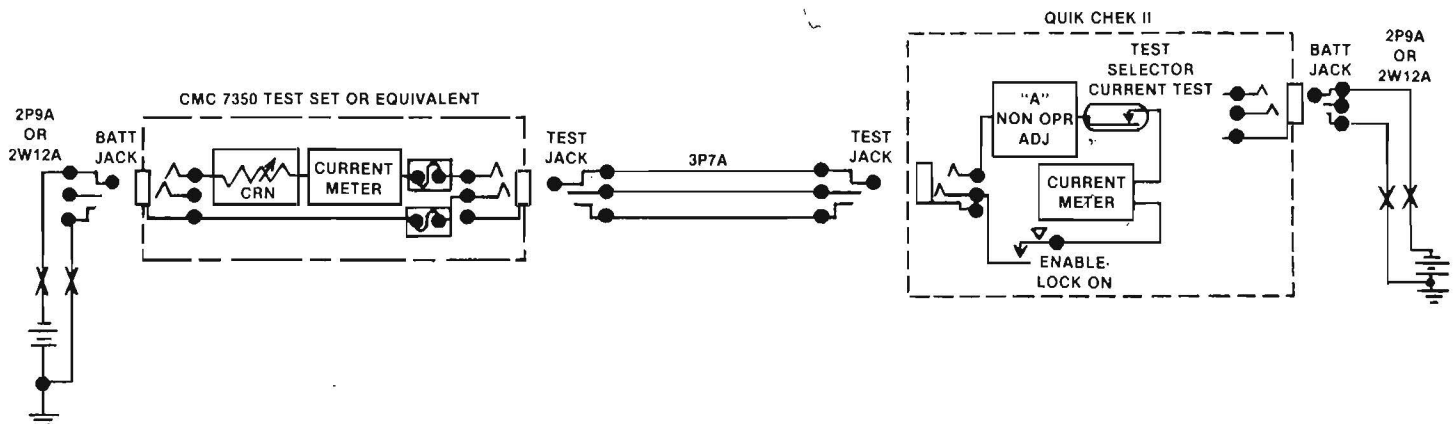

SWITCH	POSITION
FUNCTION-BATT	OPERATE
MODE-MA	OPERATE
RANGE SW-100	OPERATE
CONTROL SWITCH	OPERATE

SWITCH	POSITION
TEST SELECTOR	CURRENT TEST
ENABLE-LOCK ON	OPERATE
VALUE	NON-OPR
MODE	LOOP

Figure 5 Test Equipment Arrangement for Calibration Check of Milliammeter

**Section CMC 0708**  
**Issue D**

- (c) Insert one 3P7A Test Cord 310 plug into the CMC 7350 TEST jack. Place a short across the Tip and Ring of the other 310 plug.
- (d) Operate one of the CMC 7350 control switches and adjust the associated control potentiometer for current flow not to exceed 20 mA.
- (e) Remove the short from the 3P7A Test Cord 310 plug.

6.05 Connect the 50V central office battery supply to the Quik Chek-II BATT jack with the 2P9A or 2W12A Power Cord. Set the TEST SELECTOR switch to the CURRENT, TEST position. Turn the NON-OPERATE control fully counterclockwise to cut in all resistance. Operate the VALUE switch to the NON-OPR position and the MODE switch to the LOOP position (see Figure 5).

6.06 Using the 3P7A test cord, patch the TEST jack of the Current Flow Test Set to the TEST jack of the Quik Chek-II. Depress and lock the control switch (associated with the potentiometer adjusted in Paragraph 6.04, step D) on the Current Flow Test Set. Depress the ENABLE-LOCK ON switch on the Quik Chek-II. Adjust to a current value of 10 mA using the potentiometer on the Current Flow Test Set. Compare milliammeter readings at 10 mA, 15 mA and 20 mA, using the Quik Chek-II potentiometer to adjust to the various values beyond 10 mA.

**Volt Meter Check**

6.07 Connect the 50V central office battery supply to the CMC 7350 Test Set BATT jack with the 2P9A or 2W12A Power Cord.

6.08 Insert a 2W17A Test Cord 310 plug into the CMC 7350 TEST jack. Connect the White lead to one side of a relay coil (200 ohm). Connect the Black lead to the other side of the coil (see Figure 6).

6.09 Insert a 2W17A Test Cord 310 plug into the CMC 7350 MEAS jack. Connect the White and Black lead alligator clips to the relay coil (Paragraph 6.08). Positive (White) and negative (Black) TEST and MEAS cord leads MUST be connected White to White and Black to Black.

6.10 On the CMC 7350, depress the GND and MEAS function switches, the V mode switch and the 100 range switch.

6.11 Connect the 50V central office battery supply to the Quik Chek-II. BATT jack with the 2P9A or 2W12A Power Cord.

6.12 Insert a 3W4A (or 2W17A) 310 plug into the Quik Chek-II TEST jack. Connect the White and Black lead alligator clips to the relay coil (Paragraph 6.08). Connect White lead to White leads and Black lead to Black leads.

6.13 On the Quik Chek-II, depress the EXTERNAL-VOLTS switch and the RANGE-100 switch.

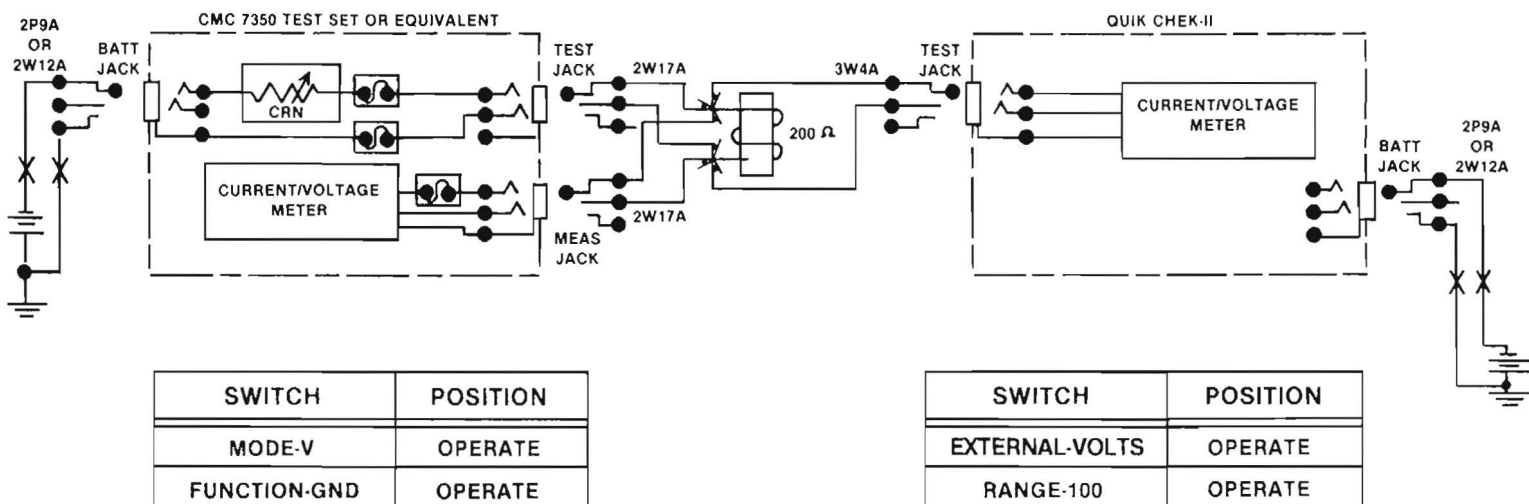

SWITCH	POSITION
MODE-V	OPERATE
FUNCTION-GND	OPERATE
FUNCTION-MEAS	OPERATE
RANGE-100	OPERATE
CONTROL SW	OPERATE

SWITCH	POSITION
EXTERNAL-VOLTS	OPERATE
RANGE-100	OPERATE

**Figure 6 Test Equipment Arrangement for Calibration Check of Voltmeter**

6.14 Operate one of the CMC 7350 control switches and adjust the associated control potentiometer for maximum voltage reading. Verify that the Quik Chek-II meter indicates within  $\pm 0.8$  volt of the CMC 7350 meter.

6.15 Adjust the control potentiometer (Paragraph 6.14) for minimum voltage reading and for mid-range voltage reading. Verify that the Quik Chek-II meter indicates within  $\pm 0.8$  volts at both settings.

**Output Pulsing Check**

6.16 Charts are run on a Mark 220 Brush Recorder or equivalent to check all the pulsing modes in the Quik Chek-II.

6.17 Connect the 50V central office battery supply to the Quik Chek-II BATT jack with the 2P9A or 2W12A Power Cord. Set the TEST SELECTOR switch to POLARITY & MON and operate the MODE switch to LOOP.

6.18 Insert a 3W4A Test Cord 310 plug into the Quik Chek-II TEST jack. Connect the other end to the Brush Recorder Channel 2 terminals as shown in Figure 7. (White lead to Terminal 2 and Black lead to ground).

6.19 Connect the Brush Recorder power cord to 110V ac. Set the SENSITIVITY SELECT switch to 1V/Div. Depress the 1mm/sec switch.

6.20 Depress and hold the Quik Chek-II TEST-RELEASE switch and adjust Brush Recorder POSITION control until the pen follows the left hand edge of the chart.

6.21 Depress and hold the Quik Chek-II TEST START switch and adjust the Brush Recorder Sensitivity Control until the pen just reaches the right edge of the chart.

6.22 If necessary, readjust the Brush Recorder Position and Sensitivity Controls alternately until the pen just reaches the edge of the chart at each end of its swing. Depress the Brush Recorder STOP switch and the Quik Chek-II TEST-RELEASE switch.

6.23 Depress the Brush Recorder 25 mm/sec SPEED switch and momentarily depress the Quik Chek-II TEST START switch. The Quik Chek-II output pulses to the Brush Recorder (see Figure 8).

6.24 Set the Quik Chek-II TEST SELECTOR switch to LOOP 1400, LKA, LP1200, LKB, SX-LP, SX-LK, C RLS MS ROT SPD and B RLS MS in sequence. Momentarily depress the TEST START switch and output pulse the set digit at each of the pulsing positions and two or three cycles at the C RLS MS ROT SPD and B RLS MS positions.

6.25 Depress the Brush Recorder STOP switch and the Quik Chek-II TEST-RELEASE switch.

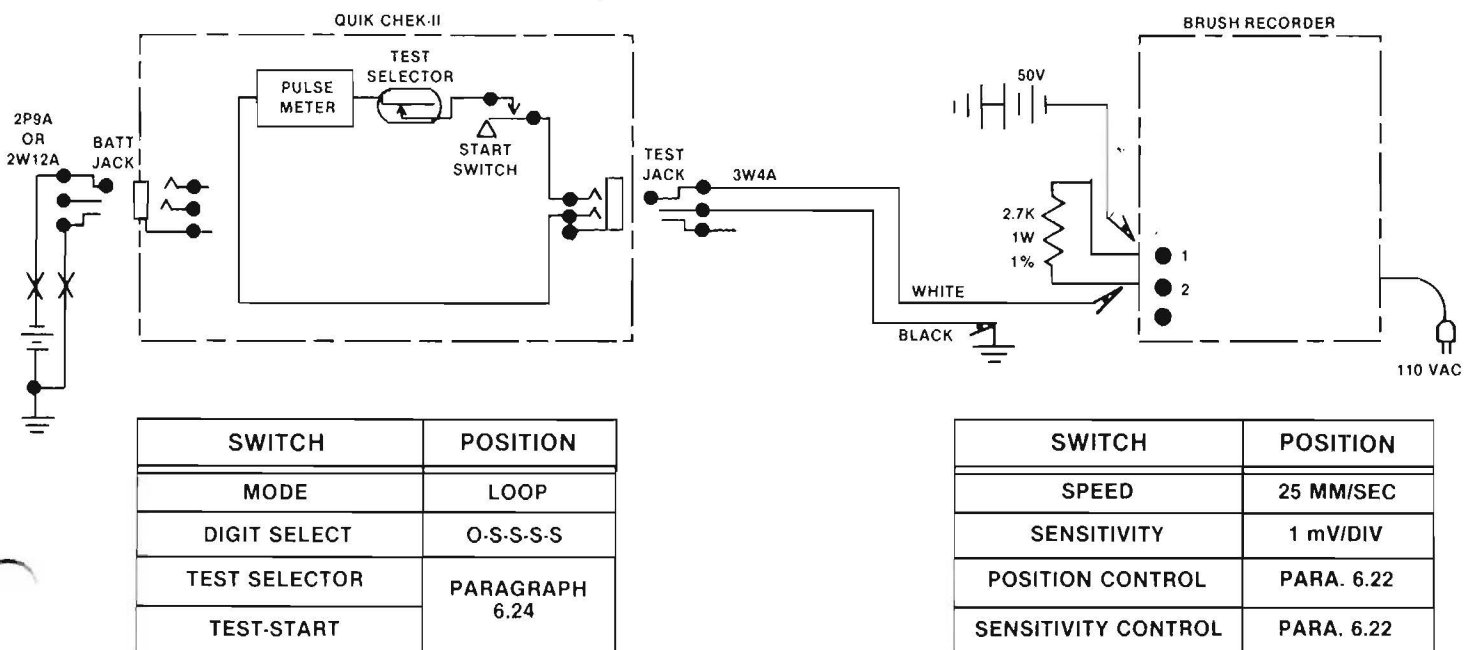

Figure 7 Test Equipment Arrangement for Output Pulsing Check

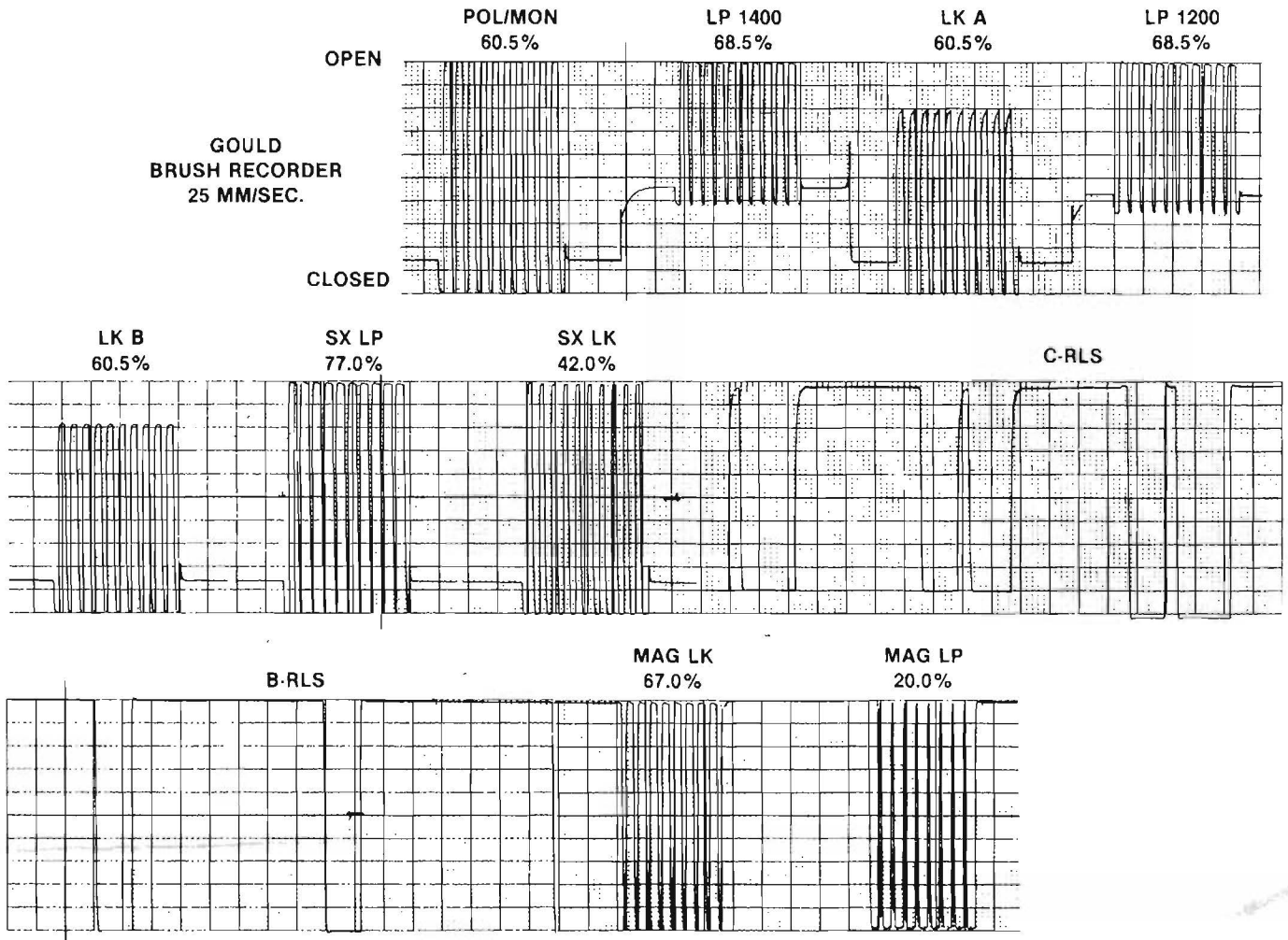

Figure 8 Typical Output Pulsing Charts for CMC 708 Quik Chek II

6.26 Remove the 3W4A Test Cord 310 plug from the Quik Chek-II TEST jack and insert it into the MAG TEST & C RLS jack. Disconnect the 3W4A alligator clips from the Brush Recorder and ground and connect the Ring (Black) lead to the Brush Recorder Terminal 2.

6.27 Depress the Brush Recorder START switch. Set the Quik Chek-II TEST SELECTOR switch to MAG LK and MAG LP in sequence. Momentarily depress the TEST-START switch and outpulse the set digit at each position.

6.28 Depress the Brush Recorder STOP switch and the Quik Chek-II RELEASE switch.

6.29 Compare the charts produced in Paragraphs 6.23 through 6.27 with the charts in Figure 8. If the charts do not match, return the Quik Chek-II to CMC for complete calibration.

## 7. REPAIR

7.01 It is not recommended that the Test Set be repaired in the field. If, at any time, it requires repairs, the Set should be returned through regular channels to the manufacturer, or to a centralized equipment repair center for repairs. A note should accompany the Unit explaining the nature of the trouble.

Permission is hereby expressly given to any operating telephone company to use or reproduce this practice in part or total for official telephone company practices, procedures or other documents.

For uses other than official telephone purposes, permission must be requested.