

PANEL DIAL SYSTEMS

by

R. E. Hersey

Bell Telephone Laboratories, Inc.
Educational Department
463 West Street
New York

(Issued for Training Purposes Only)

INDEX

<u>CHAPTER</u>	<u>TITLE</u>	<u>PAGE</u>
I	INTRODUCTION	1
II	APPARATUS	5
III	SUBSTATION EQUIPMENT	12
IV	PANEL TYPE POWER-DRIVEN LINE FINDER	14
V	THE PANEL LINK FRAME	23
VI	CONNECTING A CALLING LINE WITH AN IDLE SENDER CIRCUIT	27
VII	SUBSCRIBERS' SENDERS - APPARATUS AND FRAME	32
VIII	DIALING AND REGISTRATION	37
IX	2-DIGIT TRANSLATION - APPARATUS AND OPERATION	40
X	DISTRICT AND OFFICE SELECTOR FRAMES	45
XI	DISTRICT AND OFFICE SELECTIONS AND TRUNK HUNTING	49
XII	TRUNKING SCHEME ON OUT-TRUNKING FRAMES	55
XIII	IN-TRUNKING - SCHEME AND FRAMES	61
XIV	COMPLETING A MECHANICAL CLASS CALL	66
XV	RCI EQUIPMENT AND OPERATION	86
XVI	PANEL SYSTEM "B" BOARD AND ASSOCIATED EQUIPMENT	95
XVI-A	CALL DISTRIBUTING "B" SWITCHBOARD	102-A
XVII	KEY INDICATOR AND DIALING "A" METHODS OF COMPLETING MANUAL TO PANEL CALLS	103
XVIII	"OPERATOR CLASS" CALLS	107
XIX	PANEL SYSTEM "A" BOARD	111
XX	OTHER METHODS OF HANDLING ORIGINATING TRAFFIC	124
XXI	3-DIGIT TRANSLATION - EQUIPMENT AND OPERATION	127
XXI-A	DECODER AND DECODER SENDER	134-A
XXII	TANDEM OPERATIONS	135
XXIII	MISCELLANEOUS FRAME AND DESK EQUIPMENT	140
XXIV	ROUTINE TESTING	155
XXV	POWER EQUIPMENT	166

ILLUSTRATIONS

<u>CHAPTER</u>	<u>TITLE</u>
I	Fig. 1 - ANALOGY BETWEEN MANUAL AND PANEL SWITCHING OPERATION
II	Fig. 1 - POWER-DRIVEN SEQUENCE SWITCH Fig. 2 - POWER-DRIVEN SEQUENCE SWITCHES Fig. 3 - ISOMETRIC OF A SEQUENCE SWITCH Fig. 4 - POWER-DRIVEN INTERRUPTER
III	Fig. 1 - DESK STAND Fig. 2 - DIAL
IV	Fig. 1 - LINE WIRING AT MDF AND IDF Fig. 2 - LINE FINDER FRAME Fig. 3 - INTERRUPTER FRAME Fig. 4 - EQUIPMENT ON LINE FINDER FRAME Fig. 5 - LINE RELAY AND TRIP CIRCUIT UNIT Fig. 6 - START AND EMERGENCY TRIP CIRCUIT UNIT Fig. 7 - CABLING BETWEEN LINE FINDERS AND DISTRICT SELECTORS Fig. 8 - LOCAL CABLE ON LINE FINDER FRAME Fig. 9 - PANEL TYPE MULTIPLE BANKS Fig.10 - LINE FINDER BRUSH ROD AND TRIP MECHANISM Fig.11 - FRICTION ROLL DRIVE FOR PANEL SELECTOR FRAMES Fig.12 - PANEL SELECTOR CLUTCH Fig.13 - PANEL SELECTOR COMMUTATOR Fig.14 - ARRANGEMENT OF LINE FINDER MULTIPLE FOR 28, 40, 60 AND 80 LINE FINDERS PER GROUP Fig.15 - CIRCUIT CONVENTIONS FOR POWER DRIVEN SELECTORS Fig.16 - LAYOUT OF MOTOR DRIVE FOR PANEL TYPE FRAMES
V	Fig. 1 - PANEL LINK FRAME Fig. 2 - EQUIPMENT ON PANEL LINK FRAME Fig. 3 - CABLING BETWEEN DISTRICT AND SUBSCRIBERS' LINK FRAMES
VI	Fig. 1 - PANEL LINK HUNTING CIRCUIT Fig. 2 - PANEL LINK ALLOTTING CIRCUIT Fig. 3 - FINDING THE CALLING LINE - LINE, TRIP, START, LINK, AND LINE FINDER CIRCUITS Fig. 4 - LINE FINDER AND LINK COMMUTATORS
VII	Fig. 1 - 200-TYPE SELECTOR Fig. 2 - EQUIPMENT ON 2-DIGIT SUBSCRIBER'S SENDER FRAME Fig. 3 - EQUIPMENT ON 3-DIGIT SUBSCRIBER'S SENDER FRAME Fig. 4 - 2-DIGIT SUBSCRIBER'S SENDER FRAME Fig. 5 - 3-DIGIT SUBSCRIBER'S SENDER FRAME - NON-UNIT TYPE Fig. 6 - 3-DIGIT SUBSCRIBER'S SENDER FRAME - UNIT TYPE Fig. 7 - CABLING BETWEEN SUBSCRIBERS' LINK AND SENDER FRAMES

ILLUSTRATIONS (Continued)

<u>CHAPTER</u>	<u>TITLE</u>
VIII	Fig. 1 - REGISTRATION 2-DIGIT SENDER
IX	Fig. 1 - POWER-DRIVEN SELECTOR - 1203 TYPE
	Fig. 2 - TRANSLATION - 2-DIGIT SENDER
	Fig. 3 - SETTING THE CLASS SWITCH
X	Fig. 1 - EQUIPMENT ON DISTRICT FRAME
	Fig. 2 - DISTRICT SELECTOR FRAME
	Fig. 3 - OFFICE SELECTOR FRAME - 3-WIRE
	Fig. 4 - EQUIPMENT ON OFFICE FRAME
	Fig. 5 - TRIPPING MECHANISM
	Fig. 6 - DISTRICT AND OFFICE COMMUTATOR
	Fig. 7 - PANEL SELECTOR BRUSH AND TRIP RODS
XI	Fig. 1 - DISTRICT BRUSH AND GROUP SELECTION - CIRCUIT
	Fig. 2 - TRUNK HUNTING CIRCUIT
	Fig. 3 - OFFICE TEST AND SELECTIONS - CIRCUIT
XII	Fig. 1 - OUT-TRUNKING SCHEMATIC
	Fig. 2 - TYPICAL SLIP ARRANGEMENT FOR TRUNK MULTIPLE ON OFFICE FRAME
	Fig. 3 - TYPICAL SLIP ARRANGEMENT FOR TRUNK MULTIPLE ON DISTRICT FRAME
XIII	Fig. 1 - SCHEMATIC OF NUMERICAL TRANSLATION
	Fig. 2 - INCOMING SELECTOR FRAME
	Fig. 3 - EQUIPMENT ON INCOMING FRAME
	Fig. 4 - FINAL SELECTOR FRAME
	Fig. 5 - EQUIPMENT ON FINAL FRAME
	Fig. 6 - IN-TRUNKING SCHEMATIC
	Fig. 7 - TYPICAL SLIP ARRANGEMENT FOR TRUNK MULTIPLE ON INCOMING FRAME
XIV	Fig. 1 - TRANSLATION OF NUMERICAL REGISTRATION - 2-DIGIT SENDER CIRCUIT
	Fig. 2 - INCOMING AND FINAL SELECTIONS - CIRCUIT
	Fig. 3 - BUSY TEST CIRCUIT AND LINE MULTIPLE SLEEVE CONDITIONS
	Fig. 4 - FINAL SELECTOR CIRCUIT
	Fig. 5 - TALKING SELECTION - CIRCUIT
	Fig. 6 - TRUNK CLOSURE AND RINGING ON MECHANICAL CLASS CALL - CIRCUIT
	Fig. 7 - INDIVIDUAL, 2-PARTY, 4-PARTY SELECTIVE, AND 4-PARTY SEMI-SELECTIVE RINGING - CIRCUITS
	Fig. 8 - TALKING - BUSY REPORT - CIRCUIT
	Fig. 9 - RETURN SELECTORS TO NORMAL - CIRCUIT
	Fig. 10 - RESTORING SENDER TO NORMAL - ADVANCE OF LINK - CIRCUIT
	Fig. 11 - SENDER TIME MEASURE - CIRCUIT
XV	Fig. 1 - ROUTE OF CALL FROM A PANEL TO A MANUAL OFFICE USING DIRECT OR TANDEM RCI TRUNKS
	Fig. 2 - RELAY CALL INDICATOR POSITION
	Fig. 3 - RCI POSITION KEYSHELF
	Fig. 4 - SENDING AND RECORDING IMPULSES ON RCI CALLS - CIRCUIT
	Fig. 5 - RCI PULSE CODE

ILLUSTRATIONS (Continued)

<u>CHAPTER</u>	<u>TITLE</u>
XVI	Fig. 1 - ROUTE OF CALL FROM MANUAL TO PANEL OFFICE VIA PANEL SYSTEM "B" BOARD
	Fig. 2 - PANEL SYSTEM "B" SWBD.
	Fig. 3 - EQUIPMENT AT CORDLESS "B" POSITION
	Fig. 4 - "B" SENDER AND LINK FRAME
	Fig. 5 - EQUIPMENT ON "B" SENDER AND LINK FRAME
	Fig. 6 - CORDLESS "B" OPERATION - CIRCUIT
XVI-A	Fig. 1 - SCHEMATIC ARRANGEMENT OF CALL DISTRIBUTING "B" SWBD.
	Fig. 2 - ARRANGEMENT OF KEYSHELF EQUIPMENT
	Fig. 3 - FRONT VIEW OF CALL DISTRIBUTING "B" SWBD. AND CABLE TURNING SECTION
	Fig. 4 - SCHEMATIC LAYOUT OF CIRCUITS
	Fig. 5 - EQUIPMENT FOR CALL DISTRIBUTING "B" LINK FRAME
	Fig. 6 - SIMPLIFIED CIRCUIT SHOWING LINK ALLOTMENT
	Fig. 7 - SIMPLIFIED CIRCUIT SHOWING METHOD OF REGISTRATION IN THE SENDER
XVII	Fig. 1 - MANUAL TO PANEL-KEY INDICATOR METHOD
XIX	Fig. 1 - SEMI-MECHANICAL POSITION - PANEL SYSTEM "A" SWBD.
	Fig. 2 - MANUAL DIALING POSITION - PANEL SYSTEM "A" SWBD.
	Fig. 3 - INTERCEPTING POSITION - SEMI-MECHANICAL - PANEL SYSTEM "A" BOARD
	Fig. 4 - TEST STRIP FOR CHECKING MULTIPLE - PANEL SYSTEM "A" SWBD.
	Fig. 5 - CHECK TONE CIRCUIT
	Fig. 6 - ROUTE OF A 2-NUMBER TOLL CALL - FINAL TERMINAL CORD METHOD
	Fig. 7 - "A" POSITION SENDER AND LINK FRAME
XX	Fig. 1 - LINE SWITCH AND DISTRICT SENDER SELECTOR CIRCUIT
	Fig. 2 - SUBSCRIBER'S LINK FRAME - ROTARY TYPE
	Fig. 3 - LINE, TRIP, START, LINE FINDER, AND ROTARY LINK CIRCUITS
XXI	Fig. 1 - 3-DIGIT TRANSLATOR FRAME
	Fig. 2 - PULSE MACHINE
	Fig. 3 - PULSE MACHINE FUSE BOARD
	Fig. 4 - SENDER PULSE FUSE BOARD
	Fig. 5 - TRANSLATION - 3-DIGIT SENDER - CIRCUIT
	Fig. 6 - CABLING BETWEEN SENDERS, TRANSLATORS AND PULSE MACHINE FUSE BOARD
XXI-A	Fig. 1 - REGISTERING DIALED NUMBER IN THE DECODER SENDER
	Fig. 2 - CONTROLLING FUNDAMENTAL SELECTIONS IN DECODER SENDER
	Fig. 3 - RECEIVING AND CHECKING THE OFFICE CODE REGISTER SETTING
	Fig. 4 - METHOD OF SELECTING ROUTE-RELAY IN THE DECODER
	Fig. 5 - METHOD OF TRANSMITTING AND CHECKING SELECTIONS IN THE DECODER

ILLUSTRATIONS (Continued)

<u>CHAPTER</u>	<u>TITLE</u>
	Fig. 6 - SIMPLIFIED P.C.I. IMPULSE SWITCH
	Fig. 7 - 3-DIGIT DECODER FRAME
	Fig. 8 - 3-DIGIT SENDER FRAME - UNIT TYPE
	Fig. 9 - DECODER FRAMES
	Fig.10 - DECODERS AND DECODER TEST FRAMES
XXII	Fig. 1 - TANDEM ROUTES - 2-WIRE OFFICE AND FULL MECHANICAL TANDEM
	Fig. 2 - TANDEM ROUTES - SEMI-MECHANICAL TANDEM
XXIII	Fig. 1 - LOCAL TEST DESK - KEYSHELF AND FRONT EQUIPMENT
XXIV	Fig. 1 - EQUIPMENT ON SENDER TEST FRAME
	Fig. 2 - ARRANGEMENT FOR CONNECTING TEST CIRCUIT TO THE SENDERS TO BE TESTED
	Fig. 3 - ARRANGEMENT FOR CONNECTING TEST CIRCUIT TO THE DISTRICT SELECTORS TO BE TESTED
	Fig. 4 - ARRANGEMENT FOR CONNECTING TEST CIRCUIT TO THE OFFICE SELECTORS TO BE TESTED
	Fig. 5 - FINAL SELECTOR TEST FRAME
	Fig. 6 - WAGON TYPE TEST SETS
XXV	Fig. 1 - CHARGING GENERATORS
	Fig. 2 - MACHINE ROOM - SHOWING RELATIVE LOCATION OF UNITS
	Fig. 3 - COMMERCIAL CHARGING GENERATOR
	Fig. 4 - BATTERY CONTROL BOARD - FRONT VIEW
	Fig. 5 - BATTERY CONTROL BOARD - REAR VIEW
	Fig. 6 - BATTERY ROOM
	Fig. 7 - BATTERY DISTRIBUTING FUSE PANEL
	Fig. 8 - RINGING MACHINE
	Fig. 9 - RINGING POWER BOARD

CHAPTER I

INTRODUCTION

It is the purpose of these notes to give a brief description of the equipment, and an explanation of the operation, of the Panel Dial System of such scope and in such detail as will enable those, who are already familiar with the manually operated telephone system, to understand how telephone service is rendered by the Panel System.

Among the telephone systems in common use in the U.S. are the so-called Manual System, Step-by-Step Dial System and Panel Dial System. The Step-by-Step (also called Strowger) and the Panel systems substitute mechanical switching equipment (that is, electrically controlled and mechanically operated trunk and line selector mechanisms) for the telephone operators, in the Manual system, with whose functions you are familiar. When a subscriber, served by a Step-by-Step or Panel system office removes the receiver, a distinctive tone, called "dial tone" is transmitted to the subscriber in place of the operator's "number please". A device called a dial is then actuated by the subscriber thereby telling the mechanical equipment the number of the line with which connection is desired.

As far as the subscriber is concerned there is no distinction between service rendered by a Step-by-Step office and that rendered by a Panel office. There are, however, several fundamental differences in the central office equipment. In the Step-by-Step system the selector mechanisms are operated by electromagnets acting directly under control of the dial. Both the dial and the selector mechanisms operate on a decimal basis. In the Panel system electrical motors furnish the energy for operating the selector mechanisms. For this reason the term "power driven" is also frequently made use of in referring to the Panel system. The energy is applied to the selectors by friction clutches which are operated by electromagnets. The electromagnets are not directly controlled by the dial, for the dialed number is first recorded on a set of "registers" before the selector mechanisms are directed in accordance therewith. This indirect control permits using a selector mechanism which does not operate on the decimal basis and the decimal record from the dial must therefore

be translated to a non-decimal basis before the selector mechanisms make their selections. This non-decimal selection permits as many trunks in a group as are required to carry a certain traffic instead of dividing the trunks into groups of ten, as in the Step-by-Step system. This results in economy in the use of trunks and selective devices. As many as 90 trunks are directly accessible to a selector in the Panel system and this system would therefore appear to be peculiarly adapted for use in large cities where inter-office traffic is heavy.

The Panel system makes use of a number of circuit units in completing a connection and we will at this time be introduced to the names of some of these units and in a general way describe the function of each by analogy with manual operation. (See Figure 1). The following description applies to the operations involved in completing an inter-office call over a direct connecting trunk.

Manual Operation

The subscribers' lines terminate on answering jacks at the "A" board, with each of which is associated a line lamp.

When a subscriber in an office "K" removes the receiver to make a call, the line relay in the central office operates, lighting the lamp associated with the answering jack at the "A" board, at which the subscriber's line terminates, thus telling the operator that there is a receiver off the hook.

The plug of the answering cord is inserted in the answering jack, thus establishing a connection

Panel Dial Operation

The subscribers' lines in a Panel office terminate on rows of terminals in a "line finder bank" there being two additional rows of terminals associated with the line terminals one of which is called the "hunt" terminal.

When a subscriber in a Panel office "R" removes the receiver to make a call and the line relay operates in the central office it connects battery to the "hunt" terminal associated with the line. It also causes a "start" circuit to tell another circuit unit called a "line-finder-district" that there is a receiver off the hook.

The line finder part of the "line finder-district" hunts for the line to whose "hunt" terminal, battery has been connected and

between the operator and the subscriber.

The operator says "number please".

The calling subscriber gives his order verbally to the operator, "L 3754".

The operator tests with the tip of the calling cord the sleeves of the outgoing trunk multiple of the particular group of trunks which carries the traffic from office "K" to office "L" until she finds an idle one and inserts the plug of the cord in the jack. The telephone of a "B" operator is now automatically associated with this trunk and two zip tones are sent over the trunk to the "A" operator. The "A" operator tells the "B" operator in office "L" that a subscriber wants to be connected with "L 3754" by saying "3754".

The "B" operator looks over the plugs on which the trunks from office "K" are terminated and

when found the line finder stops thereon. At the same time that the line finder is hunting for the calling line, a "link" circuit to which the line finder-district is connected hunts for and selects an idle "sender" circuit.

The "sender" to which the subscriber's line is connected (through the line finder and link) transmits a "dial tone" to the calling subscriber.

The subscriber dials his order to the sender, "S 3754".

The sender translates the decimal dial signals by the aid of a decoder and having determined what selections are necessary to complete the connection, causes the "district selector" part of the "line finder-district" to select an idle trunk in a certain group of trunks which carries the traffic from office "R" to office "S".

The selected trunk terminates in another circuit unit called an "incoming selector". The sender causes this incoming selector

seeing that trunk 116 has a flashing lamp associated with it, tests the sleeve of one of the multiple jacks, associated with line "3754", with the tip of the plug in which trunk 116 terminates, and if line "3754" is idle, inserts the plug in the jack, ringing being started automatically.

to hunt for and connect with an idle local trunk which terminates in another circuit unit called a "final selector". The sender then causes this final selector to select and stop on a set of terminals associated with line "3754". The final selector tests the line to see if it is busy or idle. If the line is idle, the final selector connects the incoming selector thereto, and tells the incoming that the line has been selected. The incoming repeats this news to the sender. The sender causes the district selector to connect the calling line with the inter-office trunk and the sender then disconnects itself from the connection. The incoming closes the ringing circuit and when the called subscriber answers it connects the inter-office trunk to the final selector, and through the final selector to the called subscriber.

If line "3754" is busy the "B" operator inserts the plug of trunk 116 in a busy back jack thereby transmitting a busy flash to the "A" operator and a busy tone to the calling subscriber.

If line "3754" is busy the final disconnects itself therefrom and transmits a busy tone to the calling subscriber as soon as the connection between the calling line and the final selector has been completely established.

One of the greatest difficulties in developing a new type of telephone system is the limitation placed on such development by the necessity that equipment of the new system must interconnect with equipment of other existing systems. The indirect control used in the Panel system makes it easy to arrange for interconnection with systems of any other type. Means for interconnection with Step-by-Step, Manual and Toll Systems have already been developed and will be considered in these notes.

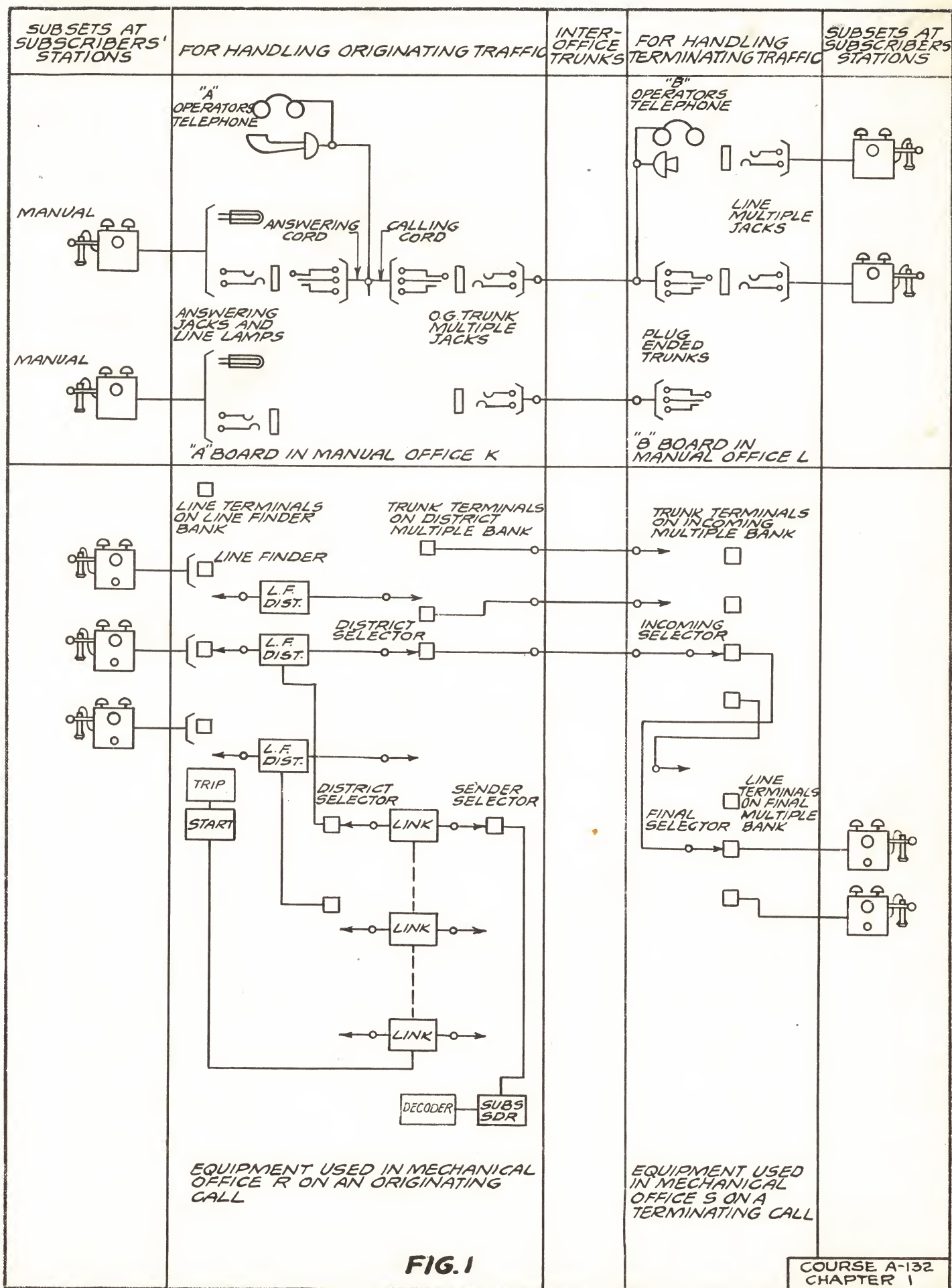

FIG. 1

CHAPTER II

APPARATUS

The Panel system makes use of nearly all the apparatus which the Manual system uses, even to including sections of switchboard very similar to the "A" switchboard of the #1 type. Of course, much of this apparatus has been modified to better meet the requirements of the Panel system and in many cases new types have been developed.

In the operation of Panel system equipment, events must occur in regular sequence and with as little delay as possible. To meet these requirements, large numbers of relays are used, including marginal, differential, polarized, slow acting and fast acting relays. "E" and "R" type relays are used as far as possible; "B", "L" or "N" type relays are used where extreme sensitivity is required; 206 type relays are used where directional selectivity is required; 207 and 208 type relays are used where extreme speed is required; 149 and 178 type relays are used where extreme slow action is required; and 114 type relays are used for controlling ringing circuits. An understanding of the characteristics and adaptability of the various types of relays is necessary in following the operation of Panel equipment. The relays are given 1, 2 or 3 letter designations on circuit and equipment drawings, the designation usually having some relation to the function of the relay.

Condensers are used in Panel equipment as in manual for transmission, in AC circuits, and with resistance for contact protection. There are, however, more cases in the panel system where contact protection is required since many of the magnets and clutches used are of low resistance and high inductance. The most commonly used types of condensers are the 89 and 90 types. Most of the resistances used are of the 18 or 19 type, this being the type which is commonly used in series with condensers for contact protection. 44 type resistances are used extensively to feed battery to electromagnetic apparatus whose windings are of low resistance, when 18 or 19 type resistances could not safely dissipate the heat generated. 40 type resistances are used when the heat to be dissipated is small and they mount like an "E" type relay. Condensers and resistances are alphabetically designated on Panel circuits and are shown symbolically in the

same manner as on manual circuits.

No special mention is thought necessary at this time in regard to other apparatus which is common to both Panel and Manual systems, but the Panel system makes extensive use of other apparatus. This includes the dial, the power driven selector and line finder, the 200 type selector, the 1202 and 1203 type selectors, the pulse machine, the sequence switch, and the power driven interrupter. Of these, only the sequence switch and the power driven interrupter will be described at this time, the description of the remainder being made later in chapters which deal with equipment units of which they are a part.

THE SEQUENCE SWITCH

The sequence switch (see Figure 1) is a rotary device used for switching a plurality of circuits in a known and positive sequence. The advantages gained by the use of a sequence switch are: 1. That it replaces a large number of relays and effects a saving thereby. 2. It exercises a more exact control of the time intervals between successive operations and of the order in which these operations occur. It consists of a metal framework, a clutch (rotary) magnet, a number of brush assemblies and a square metal shaft on which are mounted a metal clutch disc and a number of other circular discs called "cams". The shaft is supported horizontally between two bearings at opposite ends of the frame. The rotary magnet winding is mounted on one end of the framework and the clutch disc is fastened on the same end of the shaft by a flexible spider which permits movement of the disc in a horizontal direction. The spider is keyed to a metal driving collar which fits on the end of, and is shaped so as to engage with, the square shaft. A nut is screwed on to the end of the shaft against the spider and driving collar. When the rotary magnet is energized the surface of the clutch disc is pulled up against the edge of a driving disc which is mounted on, and continuously revolves with, a vertical drive shaft. The drive shaft extends the length of the frame on which a number of sequence switches are mounted and is gear driven at its lower end by an electric motor. See Figure 2. Normally, there is a small clearance between the edge of the driving disc and the surface of the driven or clutch disc.

The circular discs or cams are designated alphabetically from left

to right, the first cam at the rotary magnet end of the shaft being the A cam. The frame and shaft are made in two sizes A and B, the A switch having a maximum of 20 cams in addition to the A cam, and the B switch having a maximum of 24 cams in addition to the A cam. The A cam consists of a stamped circular phosphor bronze disc with a corrugated rim and a disc of hard durable insulating material which is riveted to the left-hand (or rotary magnet) side of the metal disc within the corrugated rim. There is a square hole in the center through which the shaft extends, the cam being rigidly secured so as to rotate with the shaft. One of the brush assemblies, which consists of three springs insulated from each other and securely held together between two metal stampings, is mounted on the framework directly behind the A cam. Attached to the end of one of these springs which extends out toward the A cam is a metal roller which engages with the left-hand side of the corrugated rim directly above the shaft. The other two springs are brush springs which extend to the rear of the metal stampings to provide terminals to which wires may be connected and which extend forward from the metal stampings so that their tips rest on the flat central portion of the right-hand surface of the A cam directly above the shaft. One of these springs, known as the right outer or #3 spring, rests on the outer rim of the flat surface and the other, known as the right inner or #4 spring, rests on the flat surface closer to the center of rotation. The wire connected to the terminal of the #3 spring is connected to ground and the #4 spring terminal is connected to the winding of the rotary magnet. The other end of the magnet winding is connected to battery. The switch has a maximum of 18 positions of rest and there are 18 waves in the corrugated rim. When the switch is in the middle of any position the A cam roller rests in the trough of one of these waves. The A cam roller acts, therefore, as a centering device. The #4 brush makes continuous contact with the A cam metal but the #3 brush does not, for the metal is notched out so that in all of the positions in which it is required that the switch come to rest the #3 brush rests on the insulating disc and not on the metal. In between the positions of rest, that is, at all points through which the switch is to move without stopping, the metal is not notched out, and the #3 brush holds the "R" magnet energized until the switch reaches the next position of rest.

The cams other than the A cam are made up of two phosphor bronze stampings which are supported by, and riveted together through, a circular disc of hard durable insulating material. The shaft extends through a square hole in the center of each cam, the cams being rigidly secured so as to revolve with the shaft. The cams are separated by metal rings or collars, the collars being insulated from the shaft by fibre washers. When adjacent cams are not to be electrically connected, the metal on the adjacent surfaces is cut away so as to clear the metal collar; but when electrical connection is desired, the metal is cut away only enough to clear the shaft and not enough to clear the metal collar. Cams which are electrically connected in this way are said to be "collared". Collars which do not electrically connect cams are distinguished, from those that do, by a groove around their outer surface. On the end of the shaft furthest from the "R" magnet is mounted an index wheel, on the periphery of which the position numbers from 1 to 18 are stamped. The cams and index wheel are so mounted on the shaft that position 1 of each cam is in contact with the brushes when the pointer is opposite position 1 on the index wheel. Outside of the index wheel a hexagonal nut screws on to the end of the shaft securely clamping the index wheel, cams, and the separating collars against the driving collar on the clutch disc. A fixed pointer, attached to the frame, points to the number of the position, on the index wheel, in which the switch is resting.

The brush assemblies other than the A cam assembly consist of 8 brush springs which are insulated from each other and securely held together between two metal stampings, one of which is fastened to the frame, there being one brush assembly mounted on the frame directly behind each pair of cams (after the A cam). On the top of the other stamping are stencilled the designations of the two cams with which the brush assembly is associated. The brushes extend to the rear of the stampings as terminals on to which the leads to the brushes are soldered, and extend forward to the cams on whose surfaces their tips rest. The ends of four of the brushes rest on the surface of one cam, and the ends of the other four rest on the surface of the other cam of the pair. There are, therefore, two springs on each side of each cam in the same relative position as springs #3 and #4 on the A cam. Accordingly the brushes are designated left inner or #1, left outer or #2, right outer or #3, and right inner or #4.

The portions of the metal discs on which the brush tips rest are notched so as to provide closures and openings in the brush circuits as are required in each particular case. Since there are 18 possible positions of rest the cam is also theoretically divided into 18 positions, each embracing an arc of 20°. When a switch is centered in a position the brush springs are located so that 10° (or 1/2 of the position) is in front and 10° in the rear of the center of the spring. When the A cam is "cut" in a position, 10° of the metal, that is, 5° on either side of the position center are cut away and the #3 spring rests on insulation when the switch is standing in this position. When any of the cams from B to Y inclusive, are "cut" in a single position, the first and last 5° of metal in this position is cut away and a single position "Cutting", therefore, consists of a 10° metal segment which extends 5° on each side of the position center. When any cam from B to Y, inclusive, is cut to close continuously for several positions, the metal segment extends from 5° in advance of brush in the beginning position to 5° beyond the brush in the terminating position.

On circuit diagrams a notation is placed adjacent to each cam spring to denote the open and closed periods during a revolution of the switch. This notation is best explained by illustration, thus, "1-2-4-6/8-12³/₄/16" adjacent to a spring indicates that there is a circuit closure when the switch is in positions 1, 2 and 4, 6 to 8 inclusive, and in positions 12³/₄ to 16 inclusive. The notation placed adjacent to the A cam is "ALL" when the A cam is cut so as to permit stopping in every one of the 18 positions, and a notation such as 1-5-17-18 indicates that the metal is so cut that the switch can come to rest only in positions 1, 5, 17 and 18.

Openings are not specifically indicated on circuits but lie between the indicated closures. Openings cannot be less than 10°. A cutting in which no metal is cut away is called a "feed" and is specified by a special symbol. If a brush is not in use, that is, it is a spare, the metal is also left uncut but the feed symbol is not used, no notation being shown adjacent to this brush. Feeds are usually inner cuttings but where two feeds are used they are sometimes both on the same side of the cam.

It must be remembered that for all cuttings the metal extends 5° in

advance of the position in which the notation indicates circuit closure and 5° beyond the position in which the notation indicates circuit opening except for 5° cuttings where the metal extends $2\frac{1}{2}^\circ$ on each side of the center.

Sketch A in figure 3, shows an isometric view of a sequence switch which is illustrative of the wiring which operates the "R" (rotary) magnet. In this sketch the winding of the "R" magnet is connected to the #4 brush on the A cam and to the #2 brush on the C cam. When the switch is resting in position 4 a circuit is closed from battery through the winding of the "R" magnet and through SS2-C and SS1-C to ground (SS2-C is the designation used for referring to the #2 brush on the C cam in circuit descriptions and on circuit requirement tables, the other brushes being similarly designated). The "R" magnet is energized and the clutch or driven disc is drawn up against the edge of the driving disc starting the switch out of position 4. Ground through SS3-A holds the rotary magnet energized until the switch is advanced far enough to be centered in position 6 with the help of the A cam roller. Sketch B in figure 3 shows all of the angles into which a cam may be divided for cam cuttings and sketch C shows the symbols used on circuit drawings which pertain to sequence switches.

The most common use of the sequence switch is that of switching a plurality of circuits in a definite and known order but the switch can also be used as a code transmitter or as a code register. A switch which is used in the transmission of a code is the RCI Impulse switch in a "Sender" circuit. This switch differs from the one we have described chiefly in the omission of the A cam and A cam roller. The RCI Impulse switch will be further considered in connection with the completion of calls from Panel to Manual offices.

Where more than one sequence switch is used in a circuit the switches are designated R1, R2, R3, etc. The cams associated with any one switch are distinguished from each other by their alphabetical designation and are also distinguished from cams on the other switches by adding the numerical subscript which applies to the switch on which it is located i.e. K₂ or M₃. In some circuits sequence switches are used so as to have normal positions, that is positions in which the switch is resting when the circuit of which it is a part is not in use. When the switch makes a complete revolution per call it has but one

normal position (position 1); when a switch makes only a half revolution per call, positions 1 and 10 are normal positions; and when it makes only onethird of a revolution per call, positions 1, 7 and 13 are normal positions. In all positions other than normal, some particular operation or operations are controlled and a "legend" is shown on the circuit naming the various positions in accordance therewith. Positions in which the switch does not stop are called "pass by" positions which may be shown in the legend or omitted. In some cases a switch has no normal position and it remains in one position until a call is originated which requires its advance to some other position. The legend also indicates in its heading the alphabetical designation of the last cam with which the switch is equipped. The legend also indicates the striping which is required on the sequence switch index wheel. This striping is for the aid of the maintenance force. Sequence switch legends are shown on most of the circuit sketches associated with these notes.

THE POWER DRIVEN INTERRUPTER

The power driven interrupter (see Figure 4) is a device for producing open and closed periods in a circuit or circuits of some required duration and sequence. The interrupter consists of a cast iron frame, usually mounted at the top of a selector frame, with a double bearing bracket at one end in which a gear driven spindle is free to revolve. The spindle is driven directly by a sequence switch drive shaft or through a reduction gear. In addition to the drive gear the spindle carries a cam assembly whose periphery engages with a roller on the end of a metal bar. The bar is supported at each end by a flat spring which fastens to the iron framework, the springs holding the roller against the cam. Rotation of the cam results in a reciprocating motion of the bar. Extending vertically on both sides of the bar are insulated studs which engage with spring assemblies attached to the frame in pairs, one above and one below the bar. The switch may be equipped with any number of pairs of spring assemblies from 1 to 15. Figure 4 also shows the symbols which are used on circuit drawings to represent the various spring combinations obtainable on a power driven interrupter.

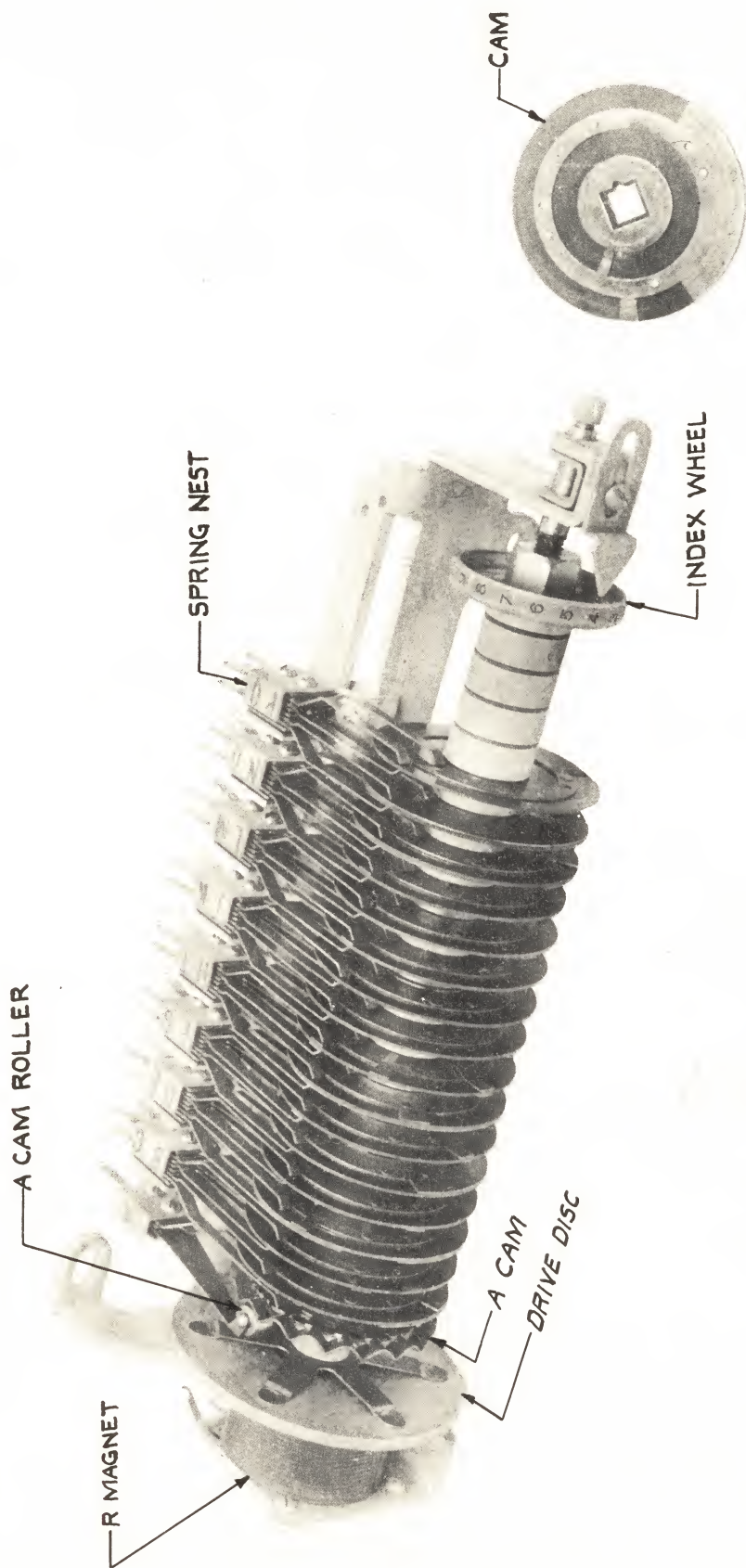

POWER DRIVEN SEQUENCE SWITCH
FIG. I

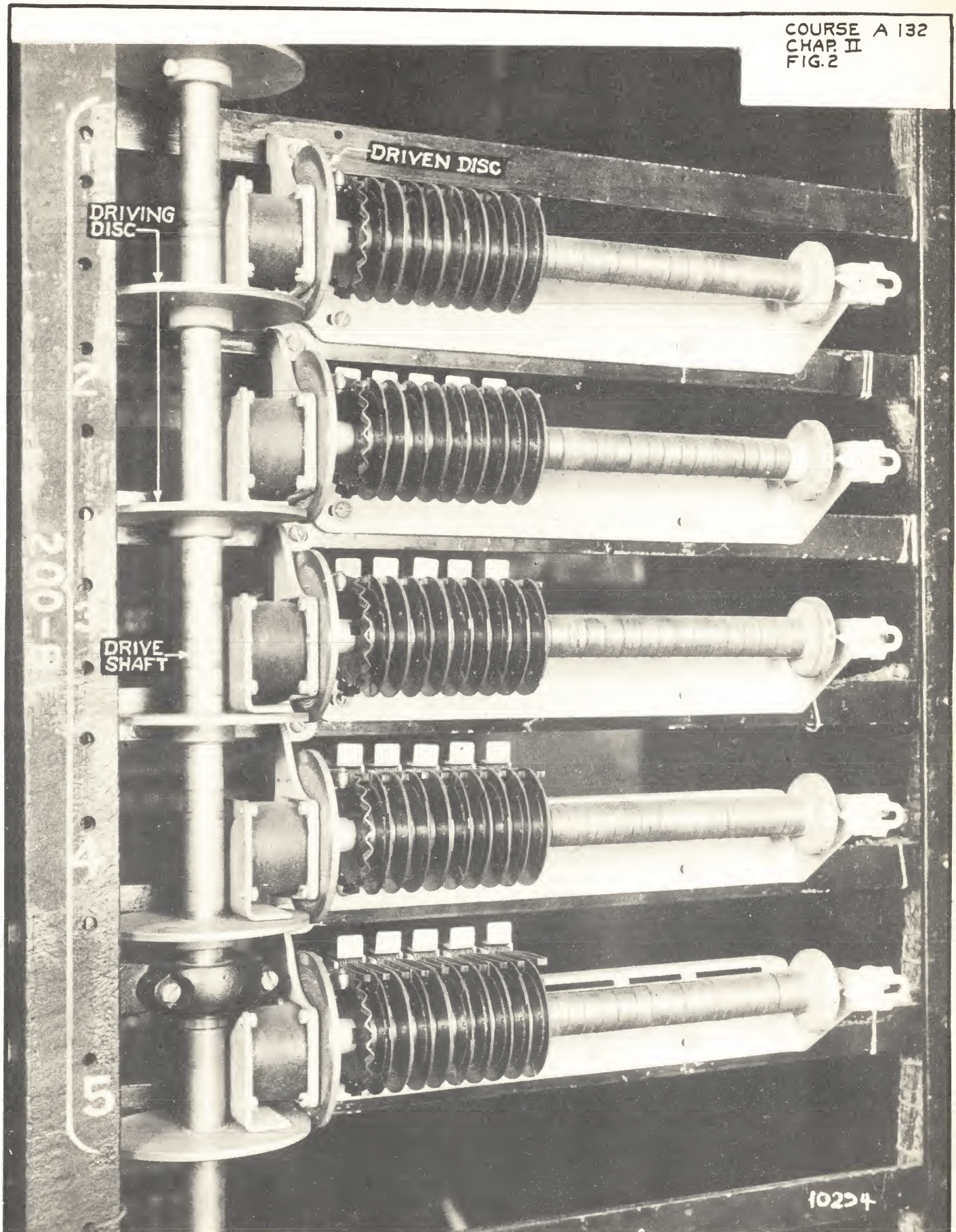

POWER DRIVEN SEQUENCE SWITCHES
FIG. 2

SCHEMATIC

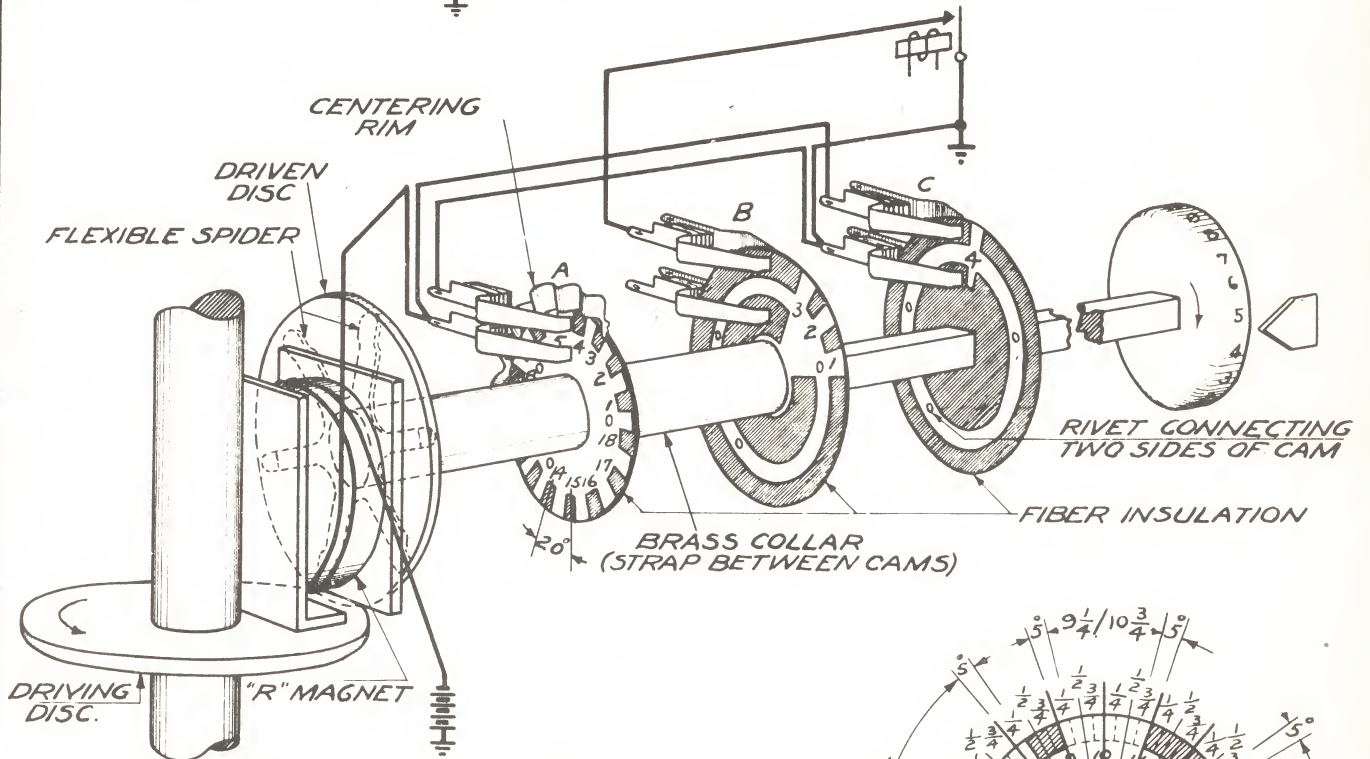
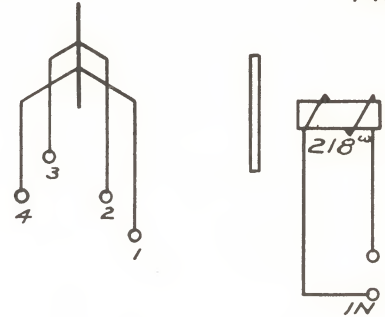
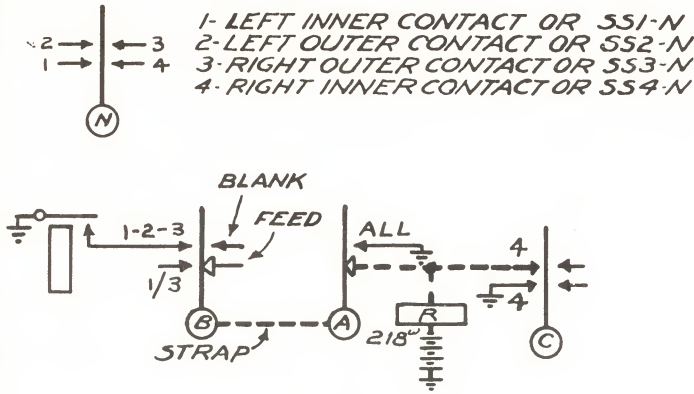

THE CAM CUTTINGS SHOWN ON A SCHEMATIC INDICATE THE CENTERS OF CLOSURES (EXCEPT FOR THE (A) CAM); THAT IS, A CLOSURE BEGINS 5° BEFORE THE CENTER AND REMAINS CLOSED UNTIL 5° PAST THE CENTER OF THE CLOSURE SPECIFIED.

THE CAM CUTTINGS SHOWN FOR THE (A) CAM INDICATE THE CENTERS OF OPENINGS; THAT IS, AN OPENING BEGINS 5° BEFORE THE CENTER AND REMAINS OPEN UNTIL 5° PAST THE CENTER OF RESTING POSITION OF SEQUENCE SWITCH.

UNSHADED PART OF CAM INDICATES CLOSURE WITH BRUSH AND SHADED PART (FIBRE INSULATION) INDICATES NON-CLOSURE.

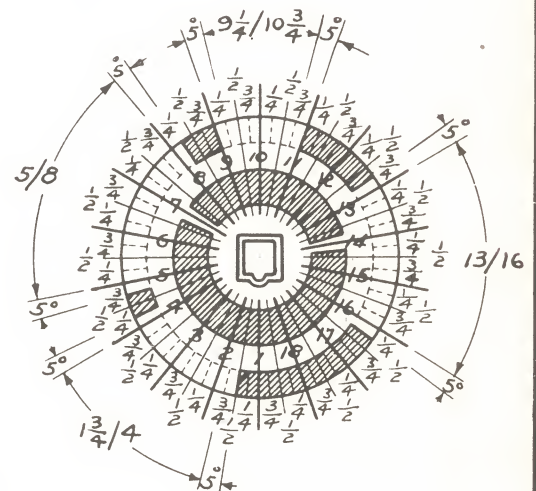

SEQUENCE SWITCH
 ILLUSTRATION OF CAM CUTTINGS
 AND CIRCUIT CONVENTIONS
 FIG. 3

SPRING ASSEMBLY CONVENTIONS

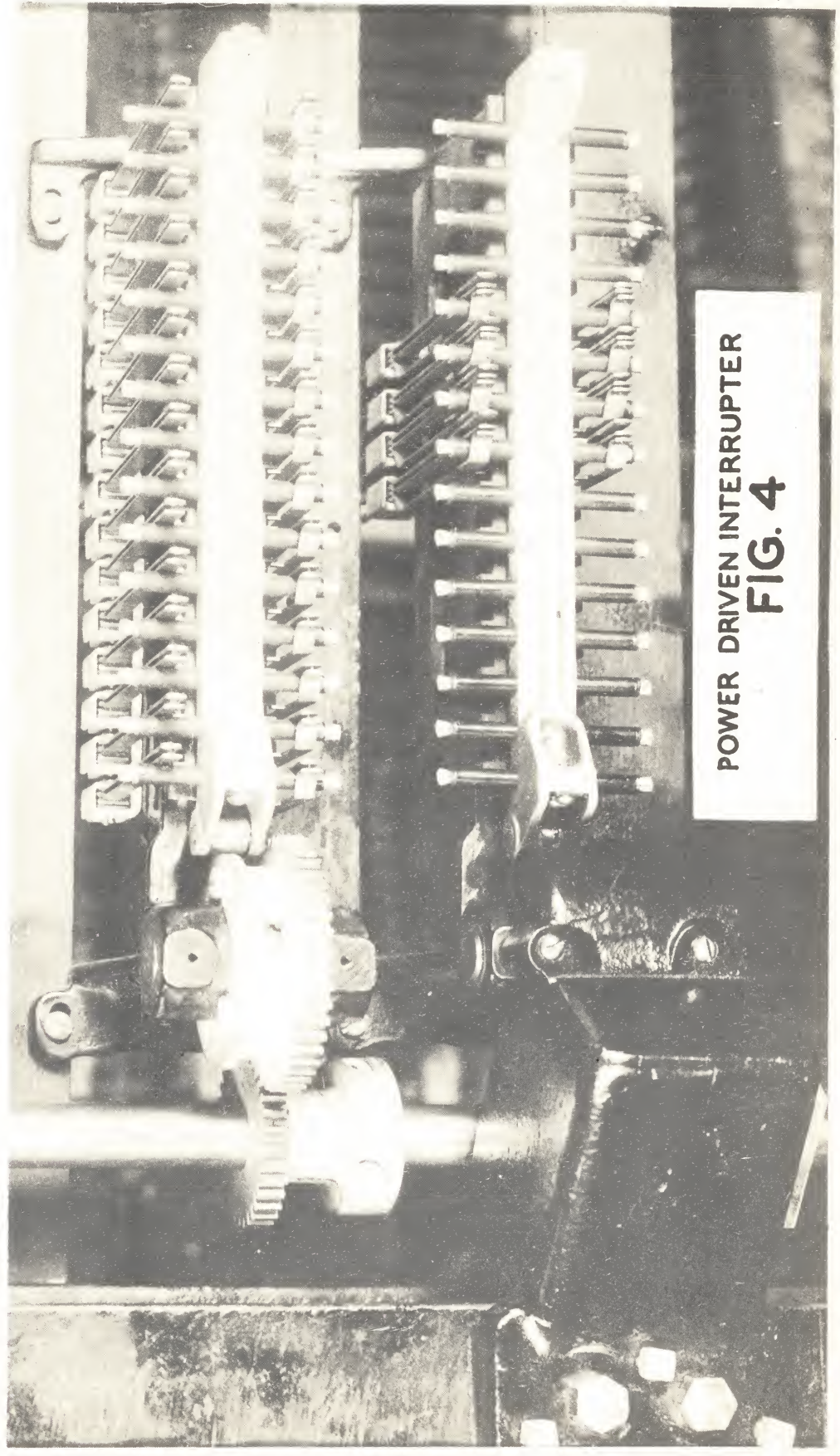
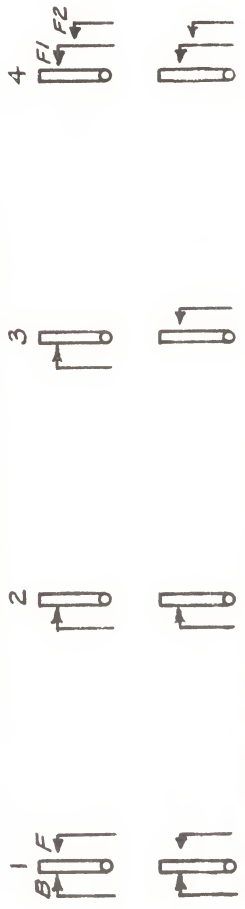

POWER DRIVEN INTERRUPTER
FIG. 4

CHAPTER III
SUBSTATION EQUIPMENT

The only change necessary in the subscriber's station equipment when converting from a manual to a mechanical basis is the addition of a "dial" by means of which the subscriber makes known the number of the line with which connection is desired. Figure 1 shows the type of desk stand used at subscribers stations which are served by Panel offices. The dial is mounted on the base, the standard having been located off center so as to make room for the dial.

The dial itself is shown in Figure 2. It is so constructed that by proper manipulation the line circuit is momentarily opened a number of times equal to the number of units in the particular digit, of the called line number, which is being dialed. The line circuit closure is therefore not only under control of the receiver hook but also under control of two normally made contact springs (called impulse springs) which are part of the dial. The movable portion of the dial consists of a shaft which carries a finger plate and impulse wheel and a governor driving gear. The finger plate has ten finger holes normally located directly above the numbers from 1 up to 0 which appear regularly spaced on a fixed plate below the finger dial. The impulse wheel which is fixed on the shaft has ten teeth in its periphery. The dial is operated by inserting the finger in one of the finger holes and rotating the dial in a clockwise direction until the finger comes up against a finger stop which is attached to the stationary part of the dial. This rotation winds the dial against a coiled spring so that when released by the finger the dial will return to its normal position. During its return to normal as many of the teeth on the impulse wheel successively engage with an "impulse pawl" as there were units in the digit which appeared under the hole into which the finger was inserted. Each time one of the impulse wheel teeth engage with the impulse pawl, a hard rubber bushing strikes one of the impulse springs and opens the line circuit contacts. The line circuit is therefore opened as many times for each digit dialed as there are units in the digit which appears directly below the hole into which the finger is inserted, except that when zero (0) is dialed the circuit is opened ten times.

The speed at which the dial returns to normal is controlled by a

centrifugal governor which is driven by the gear mounted on the dial shaft. This speed control is necessary in order that the line "open" and line "closed" intervals be of such duration as will cause registration of the digit by the central office apparatus. The dial transmits pulses at a rate of from 8 to 11 pulses per second while returning to normal. The open periods vary from .050 second to .100 second and the closed periods which occur between the open periods of a series of pulses, vary from .025 second to .050 second. In the same spring assembly with the line contact springs is an additional set of springs whose contacts are normally open. These contacts are closed during the time the dial is off normal so as to short-circuit the receiver and transmitter of the subset during transmission of the dial pulses. This prevents the impulses from being heard in the receiver and also aids registration of the number in the central office by placing a direct short-circuit across the line during the closed portions of the dial impulses.

Appearing on the fixed plate with the digits from 2 to 9 inclusive are the letters of the alphabet in groups of three, with the exception of the letters I and Z. Thus "ABC" appears with 2, "DEF" with 3, etc. The dialing of one of these letters has the same effect as the dialing of the digit with which it is associated. These letters appear in order that the system of giving office names can be maintained and the subscriber will therefore not be required to remember 6 or 7 digit numbers. Instead the exchange name and 4 digits are used to distinguish one line from another. Theoretically where an exchange area has an ultimate capacity of less than 100 offices it is sufficient to dial only the first two letters of an office name, but in an exchange area having more than 100 offices it is necessary to dial the first three letters of the office name. For this reason we have what are called, 2 digit and 3 digit systems. Practically, since letters appear only under eight of the 10 finger holes, the number of offices in a 2 digit area is limited to 64, and in a 3 digit area to 512. The choice of names in an area served by a dial system must be such that there are no duplications of the office code (first two or first three letters of the office name) and no names used which could be spelled in more than one way. The office code letters are capitalized in the telephone directory to indicate that part of the name which must be dialed.



11369

DESK STAND
FIG. I

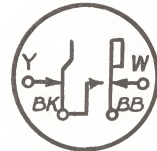

TYPICAL CIRCUIT CONVENTION



DIAL
FIG. 2

CHAPTER IV

PANEL TYPE POWER DRIVEN LINEFINDER

The subscribers' lines extend into a Panel type office through the main and intermediate distributing frames to terminals in "multiple banks" which are mounted on "linefinder frames". The Panel system gets its name from the multiple bank which is of the "panel" type. On each unit of the linefinder frame (see Fig. 1) can be mounted a maximum of ten 40 point (sets of terminals) banks of multiple terminals, and 60 sets of selecting brushes together with the driving mechanism relays, terminal blocks, and other associated apparatus. (The earlier linefinder frames were equipped with a maximum of fifteen 20 point multiple banks.) The banks, selecting brushes and clutch mechanisms are mounted in the central unit of framework; the subscribers line, trip, and start circuit relay equipment is mounted in a section on one side of the banks. (The line finder circuit relay equipment is mounted on the district frame); and the terminal blocks are mounted at one end of the frame outside of the relay equipment. In addition to the tip and ring terminals, there are two other terminals associated with each line. One of these terminals is the "sleeve" terminal and corresponds to the sleeve of an answering jack. The other is known as the "hunt" terminal and serves a somewhat similar purpose to that of the line lamp on a manual "A" board. Fig. 1 illustrates the wiring in the central office which provides for terminating subscribers' lines on the apparatus through which calls are originated. A local form carries the wiring from the terminal blocks on the linefinder frame to the line and cut-off relays and to soldering lugs on the multiple bank.

The "multiple bank", which we will now describe, is the one used when 400 subscribers' lines originate calls at such a rate that 60 linefinders are required to care for the busy hour load. Other multiple arrangements will be described later. The bank, similar to that shown in Fig. 9, is divided vertically in the middle, each half being made up of 172 metal strips placed one upon the other. The first 164 are separated from each other by strips of insulation. The 8 top strips are not insulated from each other, but are insulated from the 164th strip and from the frame. A terminal strip or punching, has 15 contact terminals on each edge and a soldering lug at each end. The metal strips are piled

in sets of 4, the lower of each set being a "sleeve" terminal strip; "ring", "hunt" and "tip" terminal strips follow in the order named. Each of the first 40 sets of 4 strips is associated with one of 40 subscribers' lines. The terminals on the four kinds of strips differ in their spacing so that they form 60 vertical rows on both the front and rear of each half of the multiple bank. These vertical rows group themselves in sets of 4, there being a "tip" row, a "hunt" row, a "sleeve" row and a "ring" row of terminals in each set, naming them in order from left to right when facing either side of the frame. The terminal strips in the bottom set on one half of the multiple bank, are connected by wires from the lugs on their inner ends to the lugs at the inner ends of the corresponding strips in the fortieth set on the other half of the bank. All other sets of strips are similarly connected from one half to the other. Therefore, if the sets of terminals in one half of the bank are associated with subscribers lines from 360 to 399 inclusive the sets of terminals in the other half of the bank are associated with the same lines but in the reverse order, that is, from 399 to 360.

The line finders which hunt over the half in which the lines number from 360 to 399 are designated sub-group "A" and those which hunt over the lines in the reverse order are designated sub-group "B". The lines also are divided into two sub-groups. The lines from 360 to 379 being in sub-group "A" and the lines from 380 to 399 being in sub-group "B". The controlling circuits are so arranged that, when a line in sub-group "A" (in any one of the 10 banks) originates a call, a line finder in sub-group "A" is used to find and connect to the calling line, except that when all the line finders in sub-group "A" are busy then a line finder in sub-group "B" will be used if there be an idle one. Similarly, lines in sub-group "B" are served by line finders in sub-group "B" unless they are all busy, in which case a line finder in sub-group "A" is used if there be an idle one. This arrangement of multiple reversal and division of lines and line finders into sub-groups reduces the average time required for a line finder to connect with a calling line and therefore reduces the possibility of a subscriber dialing before the line is connected to a sender circuit in which the number about to be dialed will be registered.

At one end of the bank, the "tip", "hunt", "ring" and "sleeve" strip

soldering lugs (first 40 sets only) are connected by wiring in the local form to the "T", "R", "S" and "M" terminals on a terminal block which mounts at that end of the linefinder frame. This wiring is quite clearly shown in Figs. 1 & 2. The forty-first set of terminal strips and the group of 8 strips on the top are not connected to subscribers' lines. In addition to serving as brush guides they are used as "tell tale" terminals, a use which will not be explained at this time.

In front of each set of vertical rows of "T", "H", "S" and "R" terminals in the multiple bank is located a brush rod on which are mounted 10 multiple brush assemblies or "multiple brushes", one for each bank on the frame, and one commutator brush. (see Fig. 10). There is, therefore, space for 30 brush rods on each side of the frame an arrangement which makes for economy in the use of floor space. Vertical movement of the rod, a distance equal to the height of a multiple bank, brings each set of line terminals on the entire frame within reach of one of the 10 brushes on each of the 60 brush rods. A linefinder multiple brush consists of a metal framework which supports 4 contact springs insulated from each other. A spring separating device which engages the two inner springs, normally keeps the springs spread apart so that they cannot make contact with the line terminals. The device consists of a metal detail hinged to a projection at the bottom of the brush framework. The detail supports a pair of rollers normally wedged between the two inner springs. Extensions of the hinged detail serve as "trip" and "reset" levers. When the brush is tripped, that is, the "trip lever" has been pulled down from its normal position, the roller swings out from between the inner pair of springs so that all four brushes make contact successively with the vertical rows of terminals, when the brush rod is moved upward. The trip mechanism consists of 2 trip magnets attached to the linefinder frame at one end of, and just below each multiple bank, one on each side of the frame (see Fig. 2). When the trip magnet is energized, it engages with and causes the rotation of a horizontal trip rod through an angle of about 30°. This trip rod extends the length of the bank just above the brush rod bearing plates and is held in its normal angular position by a retractile spring. Attached to the trip rod are 30 trip fingers, one for each brush rod on the same side of the frame. Rotation of the trip rod moves these

trip fingers into such a position with respect to the trip levers on all of the 30 brushes which are associated with this particular bank that if any one of these brush rods is driven upward the brush on this rod is tripped, so that the springs make contact with the bank terminals. The ends of all brush springs are provided with insulating shoes in which the contact mechanism is embedded, the shoes acting as guides for the springs. The left outer and left inner springs ("tip" and "hunt") make contact with the left side of the tip and hunt terminals respectively, and the right outer and right inner springs ("ring" and "sleeve") make contact with the right side of the ring and sleeve terminals respectively. The trip magnets associated with only one multiple bank can be operated at one time, otherwise a finder might be electrically connected to the terminals of two or more different lines at the same time. The reset lever extends below the brush when in the tripped position and to reset the brush, this lever must be pushed up to its normal position so that the rollers reenter between the inner pair of brush springs. At the bottom of each bank there is a comb for guiding the brushes on to the terminals in each vertical row. This comb consists of pieces of aluminum casting, fastened to the multiple bank frame, there being vertical ribs on the outer surface of these castings. At the top of the bank, the 8 additional terminal strips serve as guides and no comb is necessary.

The brush rod on which the multiple brushes are mounted is a hollow metal tube held in place and guided by bearing plates at the bottom of each bank with the exception of the bottom bank. A bearing plate is not placed at the bottom of the lowest bank for the reason that the brush rod extends only to the bottom of this bank and would move out of the bearing each time it is elevated. Within the rod is carried the wiring which connects the corresponding springs of each of the 10 brushes.

Attached to the lower end of the rod is a flat strip of bronze known as a "rack". There are rectangular slots in the strip on 1/6" centers corresponding to the spacing of the sets of line terminals in the multiple bank. The rack is somewhat longer than the height of a multiple bank. On each side of the frame, the brush rod racks extend downward in front of two "friction rolls" which are mounted horizontally one above the other. The rolls (shown in Fig. 11) are gear driven by small electric motors, there being one motor for the

rolls on the same side of two adjacent frames. Each of the rolls consists of a steel shaft covered with a layer of cork the upper roll being the down-drive roll and the lower one the up-drive roll. The two rolls in each set revolve in opposite directions, one of them being known as the "up-drive" roll, the other as the "down-drive" roll. In front of the two "friction rolls" on each side of the frame, are mounted 30 "clutch" assemblies, one associated with each of the 60 brush rods on the frame. The line finder "clutch" consists of an up-drive ("UP") magnet and roller, a down-drive ("DOWN") magnet and roller, a pawl and a pawl trip lever, all mounted on a metal framework. (The clutch used on a final selector is shown in Fig. 12. On the line finder clutch the top and bottom magnets shown are omitted.) The up-drive roller presses the rack against the up-drive friction roll when the UP magnet is energized causing the brush rod to move upward. When the UP magnet releases, the brush rod drops back against the pawl which has engaged with one of the slots in the rack. This pawl is pivoted on the clutch framework and is tensioned toward the rack at all times, by a retractile spring. An index stamped on the edges of the face of the rack, indicates, with reference to the top of the clutch magnet assembly, the number of the set of line terminals in each bank opposite which their respective multiple brushes are resting. When the down-drive magnet is energized, the pawl trip lever disengages the pawl from the rack following which the down-drive roller presses the rack against the down-drive friction roll, returning the brush rod to normal. If one of the brushes has been tripped, the reset lever of this brush strikes the trip lever rod, causing the trip lever to be pushed up to its normal position, thereby resetting the brush. Just above two of the multiple brushes, up-stop collars are attached to the brush rod to limit its upward motion. A down-stop detail is collared to the lower end of each brush rod and this stop detail carrying the weight of the rod, brushes and rack normally rests against the top plate of the clutch framework.

Attached to the upper end of the brush rod is a set of brush springs called a "commutator brush" (see Fig. 13). The "T", "H", "S" and "R" springs of the multiple brushes are connected by the wiring which is carried inside of the brush rod, to the corresponding springs of the commutator brush, and, as the brush rod moves upward, these springs slide along on the surface of the

"commutator", making contact with similarly designated commutator segments. A commutator is a bar of insulating material in which are embedded a number of metal strips. It is fastened by a steel detail called a "commutator locating plate", to the top of the frame in such a position that the commutator brush springs make contact with and slide over its segments when the brush rod is driven upward. The metal strips terminate at one end in soldering lugs which are wired to other apparatus in the linefinder district circuit as required. The commutator and commutator brush are, therefore, necessary in completing a connection between the circuit of which a particular line finder is a part, and a set of multiple bank terminals with which one of the multiple brushes is in contact. The commutator brush also has other springs designated "G", "M", "N", "K" and "X", and "C", all of which are strapped together but each of which makes contact at various times with separate but similarly designed segments on the commutator. These brushes and segments are used to control various circuits and their use will be explained when describing that part of the operation in which they come into play.

There is one regular trip circuit for controlling the trip magnets and the relays used in this trip circuit are mounted with the line and cut-off relays at one end of the bank with which they are associated. An emergency trip circuit is mounted above the relay equipment at the end of the top multiple bank. Connection is made to each regular trip circuit by inserting a plug in a jack adjacent to the relay equipment. Transfer of this plug to the emergency set of springs in this jack box, cuts in the emergency trip circuit in place of the regular one. In this way, the one emergency trip circuit can be used in place of any one of the 10 regular trip circuits.

There is one "start" circuit for the group of 60 linefinders on the frame which we have described and the relays used in this circuit are mounted at the top of the frame just above the emergency trip circuit relays. Relays for an emergency start circuit are mounted just above the relays for the regular start circuit, and the emergency start circuit can be "cut into service" in place of the regular circuit by moving a plug in the jack associated with the start circuits. Below the relay equipment is mounted a fuse panel, which feeds battery and ground as required by the line trip, and start circuit

apparatus mounted on the frame. The individual line finder apparatus is fed thru fuses on the district frame. Jacks used for testing and maintaining the equipment on the frame are grouped on jack mountings attached to the framework at the end of the multiple banks next to the relay equipment. The power driven interrupters which are associated with the line finder circuits on a linefinder frame are mounted on a separate interrupter frame which is shown in Fig. 3.

We have mentioned that there is a local form associated with each multiple bank which carries the wiring between the multiple bank, line and cut-off relays, and the line terminal blocks. The local cabling on a line finder frame consists of the following:

1. Two line finder local cables.
2. Ten multiple bank-line relay and trip circuit local cables for each line relay bay.
3. One start and emergency trip circuit local cable for each start circuit unit.
4. One local cable for each line relay bay.
5. One local power cable for each line of frames.

Each line finder local cable ties together the clutches, commutators and miscellaneous jacks associated with the line finders on one side of the frame and is terminated on the four terminal strips near the top of the left upright of the bay. One subscriber's line relay and trip circuit local cable is required with each line relay unit and associated bank or banks. The cable extends from the multiple bank and trip magnet terminals past the relay equipment and trip circuit jack to the line relay unit terminal strip. When the subscriber's lines are multiplied before two line finder frames as on a 40 and 80 line finder group the local cable is extended from the terminal strip to the soldering terminals of the adjoining multiple bank. The start and emergency trip circuit relays are connected by the start and emergency trip circuit local cable to the jack thru which connection to the start circuit is made. The line relay bay local cable connects the start circuit equipment and the battery leads with the ten line relay and trip circuit units. It extends between the terminal strip of the units and the fuse panel with an arm connecting to the terminal of the start circuit jack. One local power

cable is required for each line of line finder frames to carry the miscellaneous leads running between the two sides of the same frame, between adjacent frames, and from points beyond the line finder frames, to the distributing power terminal strip which is located at the end of the line-up. From this point the leads are carried in switchboard cable to the power alarm board, IDF etc. The miscellaneous leads of the line finder circuit are picked up by the local power cable at the power terminal strip of this bay and those of the line relay bay at the power punching of the start circuit unit terminal strips. Figure 8 shows the arrangement of the various line finder local cables. The line finder district circuit are cabled in groups of five and the number of cabled line finders on a frame will be a multiple of this number.

The line finder bank which has been described was the one used when 400 subscribers lines originate such an amount of traffic as requires the use of 60 line finders. Other multiple bank arrangements are used whereby 28, 40 or 80 line finders are grouped together to care for the traffic which is originated by 400 lines. In these cases the multiple bank is divided vertically and the multiple strips are divided into sections. There are two trip magnets one on each side of the frame for each group of lines and the trip rods actuated by these trip magnets extend only the length of the group and not the length of the frame. Figure 14 illustrates the bank arrangements for the 28, 40, 60 and 80 line finder groups.

Each one of these line finder units is a part of and is used in the circuit unit called the "line finder - district". The line finder - district includes a district selector which is somewhat similar to a line finder for it also consists primarily of a brush rod, multiple brushes, a clutch mechanism, a commutator and a commutator brush. The district selector is mounted on a frame which is also somewhat similar to a line finder frame. The line finder and district selector parts of the line finder district circuit are connected by switchboard cables. Each cable carries the wires for connecting 5 circuits (6 leads per circuit) and terminates on terminal blocks mounted on the end of each of the line finder and district frames. The relays, resistances, and sequence switch associated with each line finder - district circuit are mounted on the district selector frame and not on the line finder frame.

Course A-132
Chapter IV

The symbols used on circuit drawings to represent various parts of the power driven line finder are shown in Figure 15. These symbols are used in a similar manner for all power driven selectors.

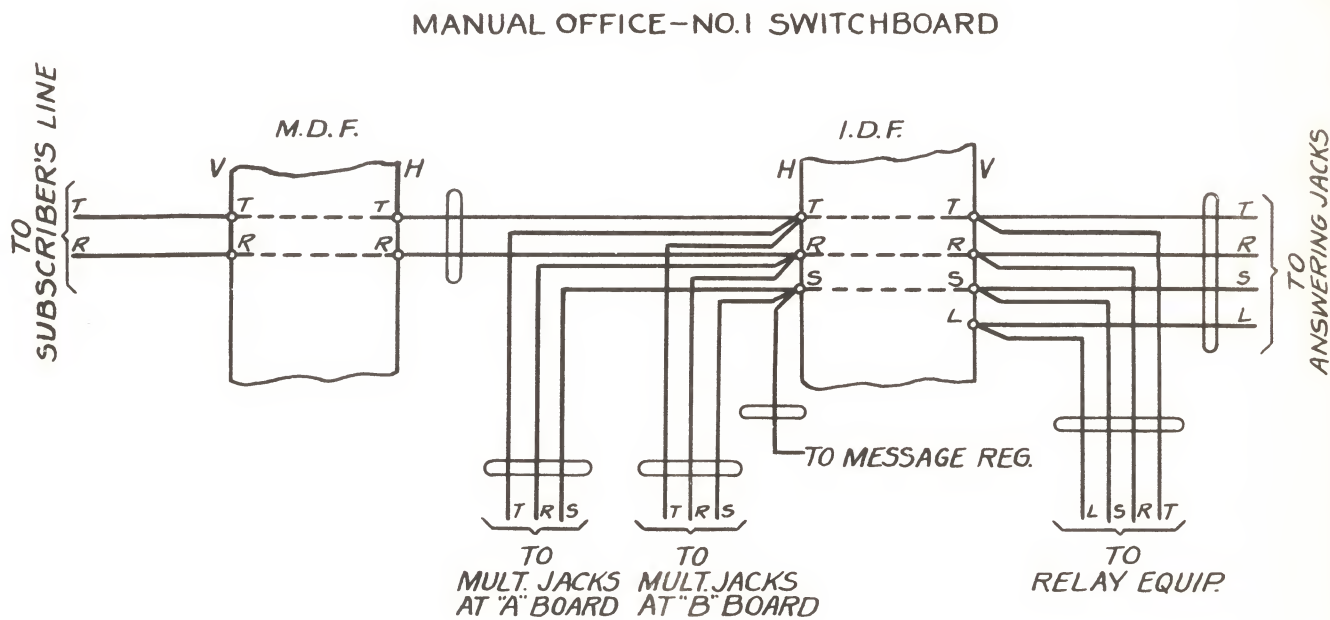
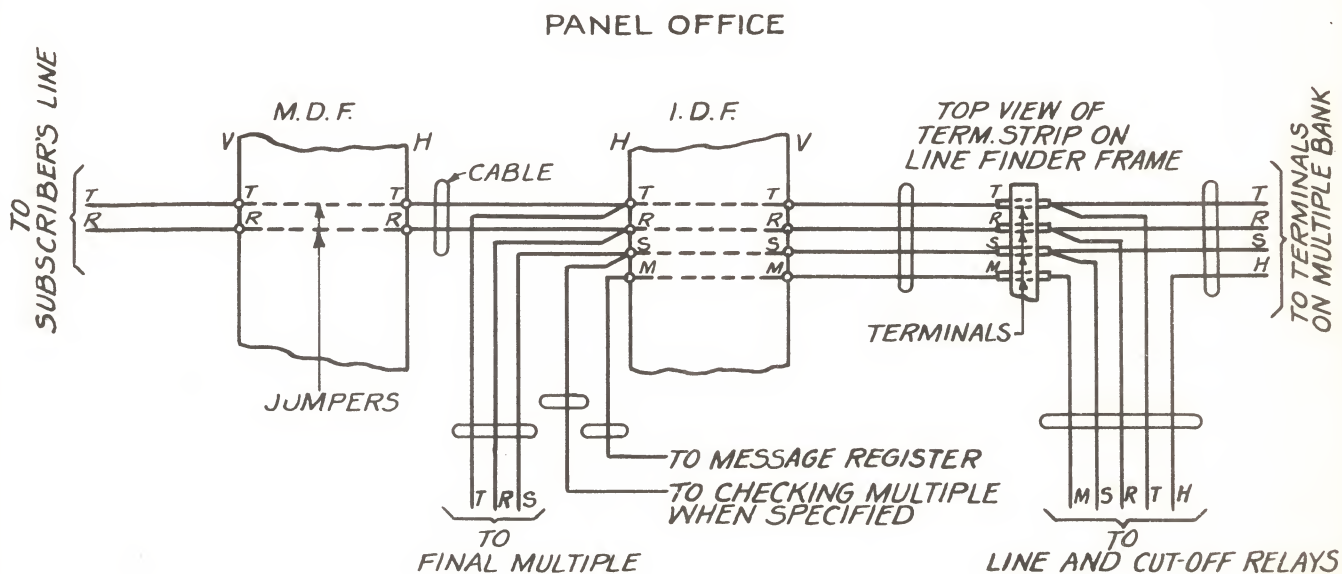

**METHOD OF
 CABLING AND CROSS-CONNECTING SUBSCRIBERS' LINES
 FIG. I**

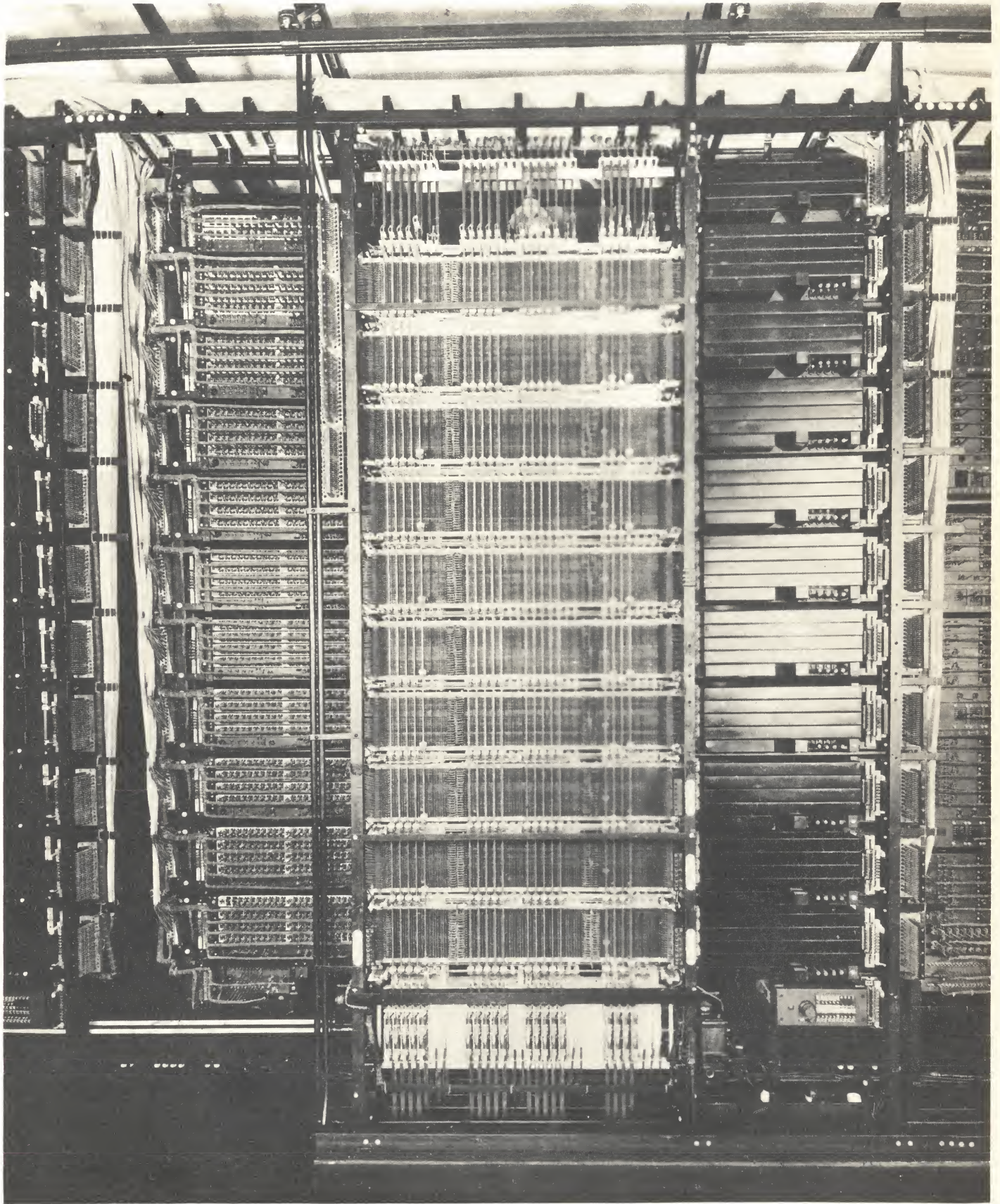

LINE FINDER FRAME - 28 L.F. GROUP
FIG. 2

INTERRUPTERS
FOR START CKT.
TIME ALARM

STB-REG. →
STA-REG. →
STB-EM. →
STA-EM. →

G9 & G10 →
G7 & G8 →
G5 & G6 →
G3 & G4 →
G1 & G2 →

INTERRUPTERS
FOR TRIP CKTS.
TIME ALARM

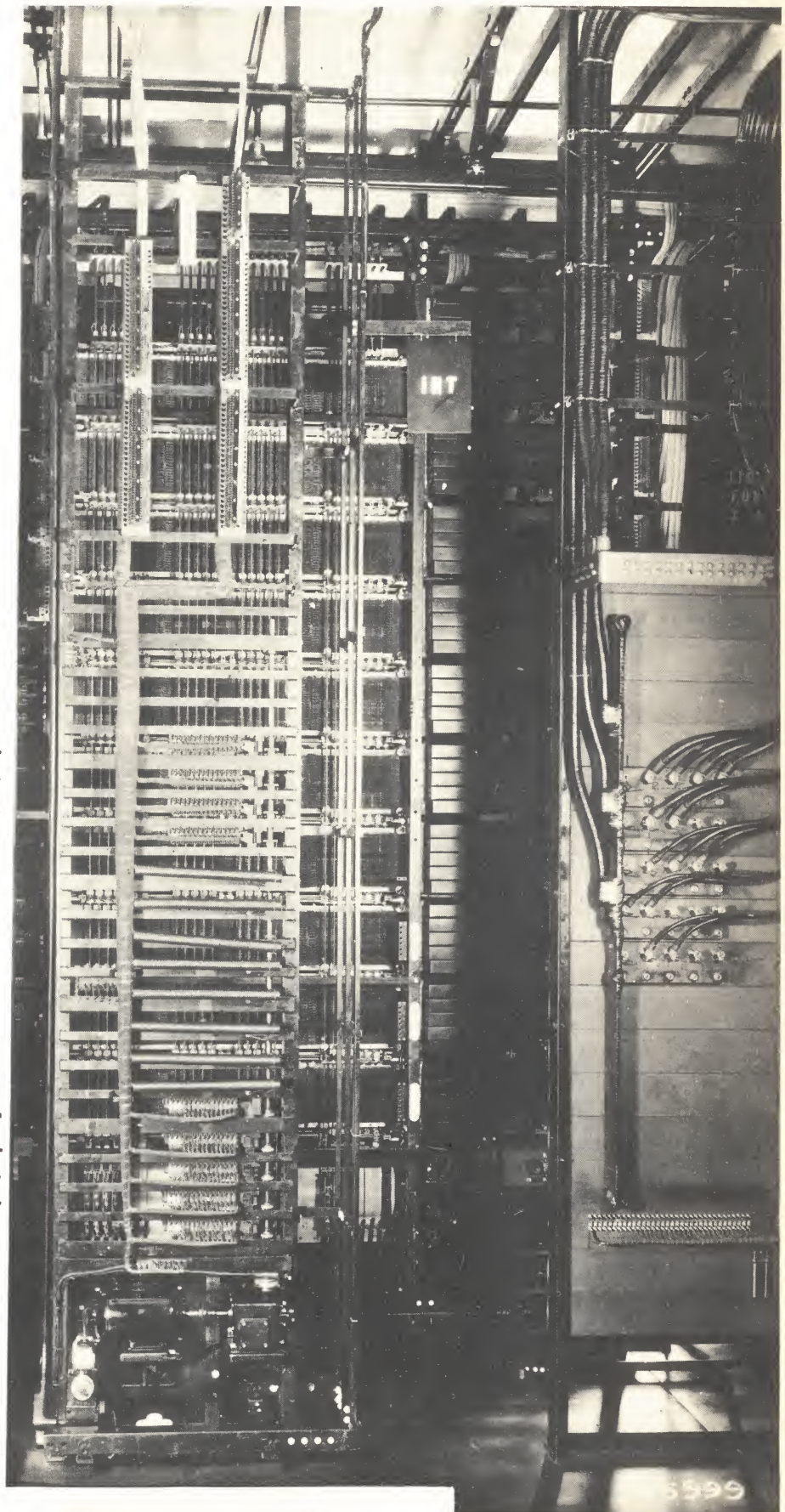

INTERRUPTER FRAME
FIG. 3

134-TERM. STRIP.
 TERMINAL STRIP DESIGNATIONS FOR F.R.
 INDIVIDUAL M.R. AND COIN LINES.

399	M	398	I
397	S	396	R
393	B	392	T
389	R	388	M
385	I	384	S
381	M	380	T
377	S	376	R
373	B	372	I
369	R	368	M
365	I	364	S
361	M	360	T
40	---	33	---
24	---	17	---
8	---	1	---

POWER ○ 360 ○ SUBS LINES ○ 399 ○

156-A TERM. STRIP.
 TERMINAL STRIP DESIGNATIONS FOR
 TWO PARTY MESSAGE RATE LINES.

399	M	398	I
397	S	396	R
393	B	392	T
389	R	388	M
385	I	384	S
381	M	380	T
377	S	376	R
373	B	372	I
369	R	368	M
365	I	364	S
361	M	360	T
50	---	41	---
30	---	21	---
10	---	1	---

POWER ○ 360 ○ SUBS LINES ○ 399 ○

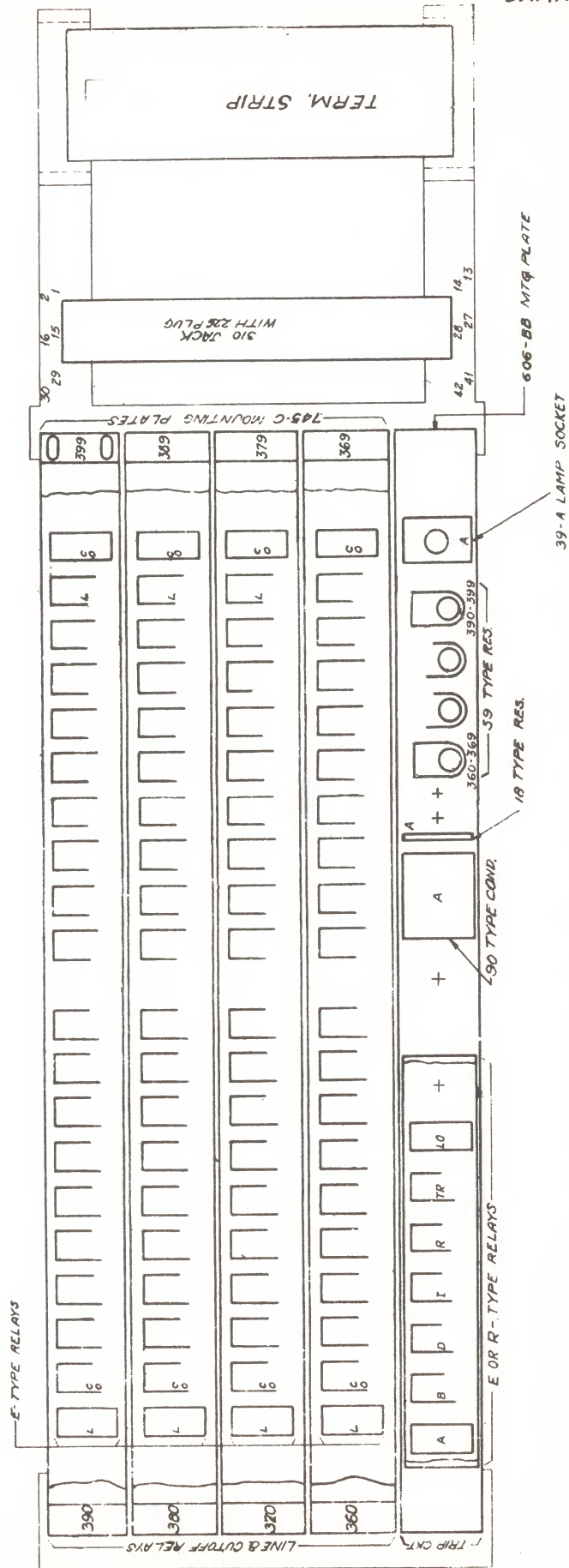

400 POINT LINE FINDER FOR USE WITH SUBSCRIBERS' LINKS
 Equipment of Line Relay and Trip Circuit Unit

FIG. 5

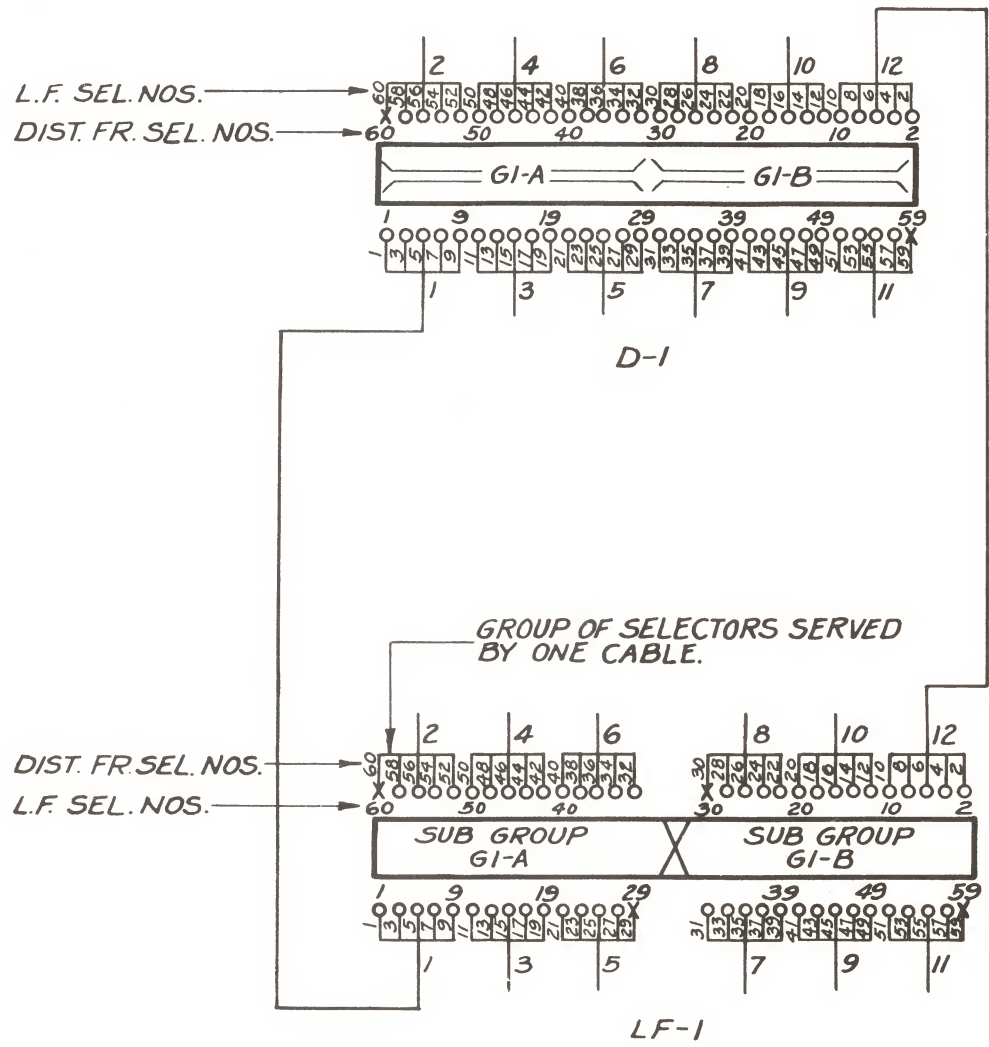

CABLING OF 60 LINE FINDER GROUP
 LINE FINDER TO DISTRICT
FIG. 7

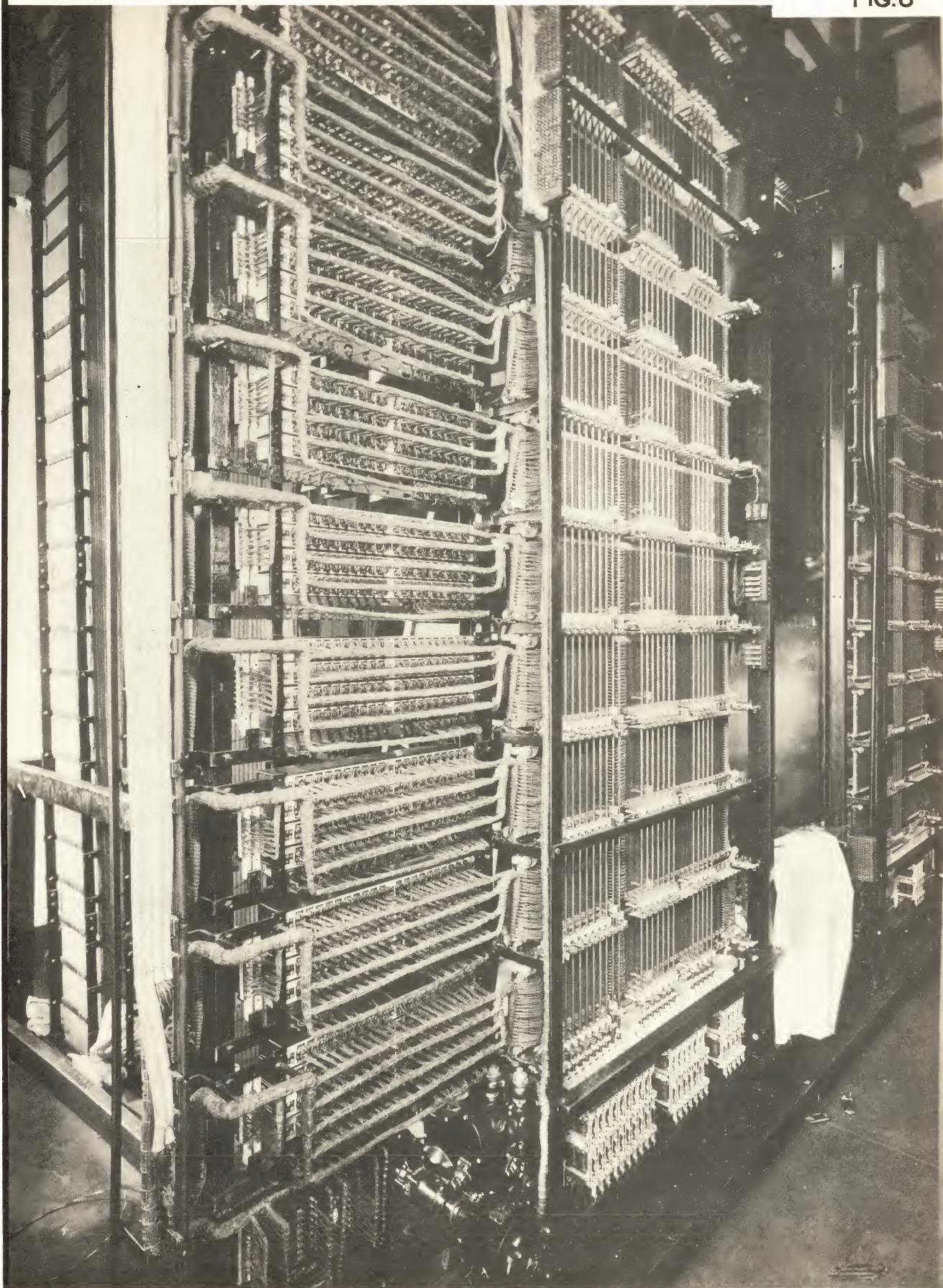

LOCAL CABLE ON LINE FINDER FRAME
FIG. 8

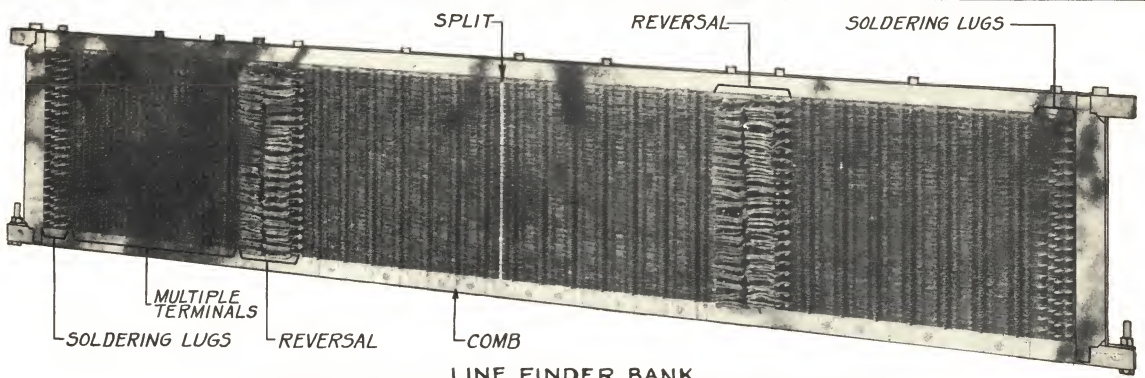

LINE FINDER BANK
40 SETS OF S,R,H,&T MULTIPLE TERMINAL STRIPS

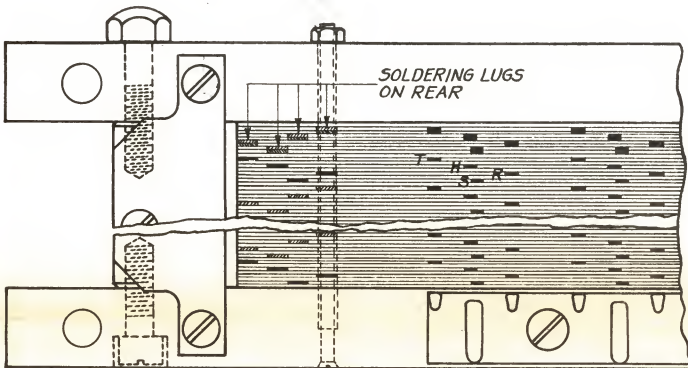
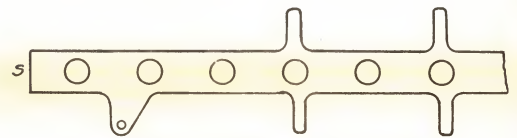
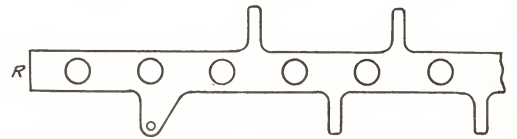
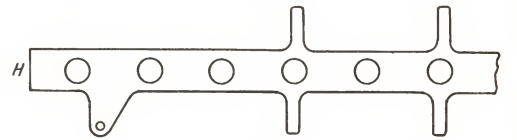
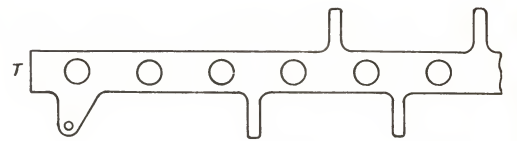
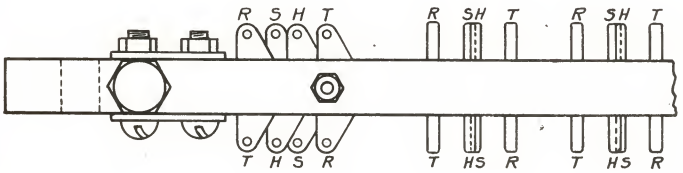

PARTIAL FRONT AND PLAN VIEWS
OF LINE FINDER BANK

MULTIPLE TERMINAL STRIPS
OF LINE FINDER BANK

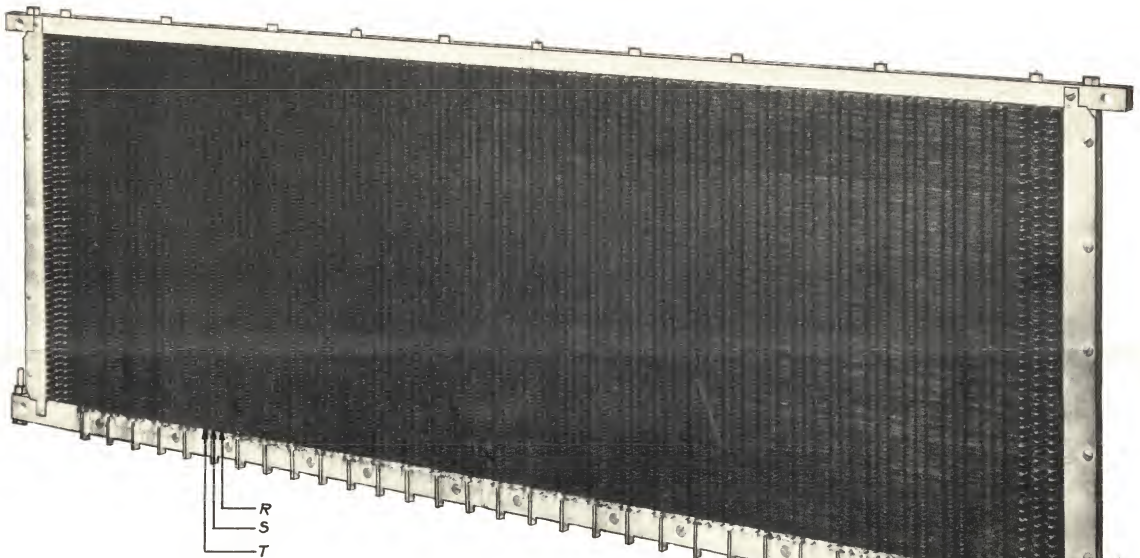

TRUNK HUNTING SELECTOR BANK
100 SETS OF S,R,&T MULTIPLE TERMINAL STRIPS

PANEL TYPE BANKS
FIG. 9

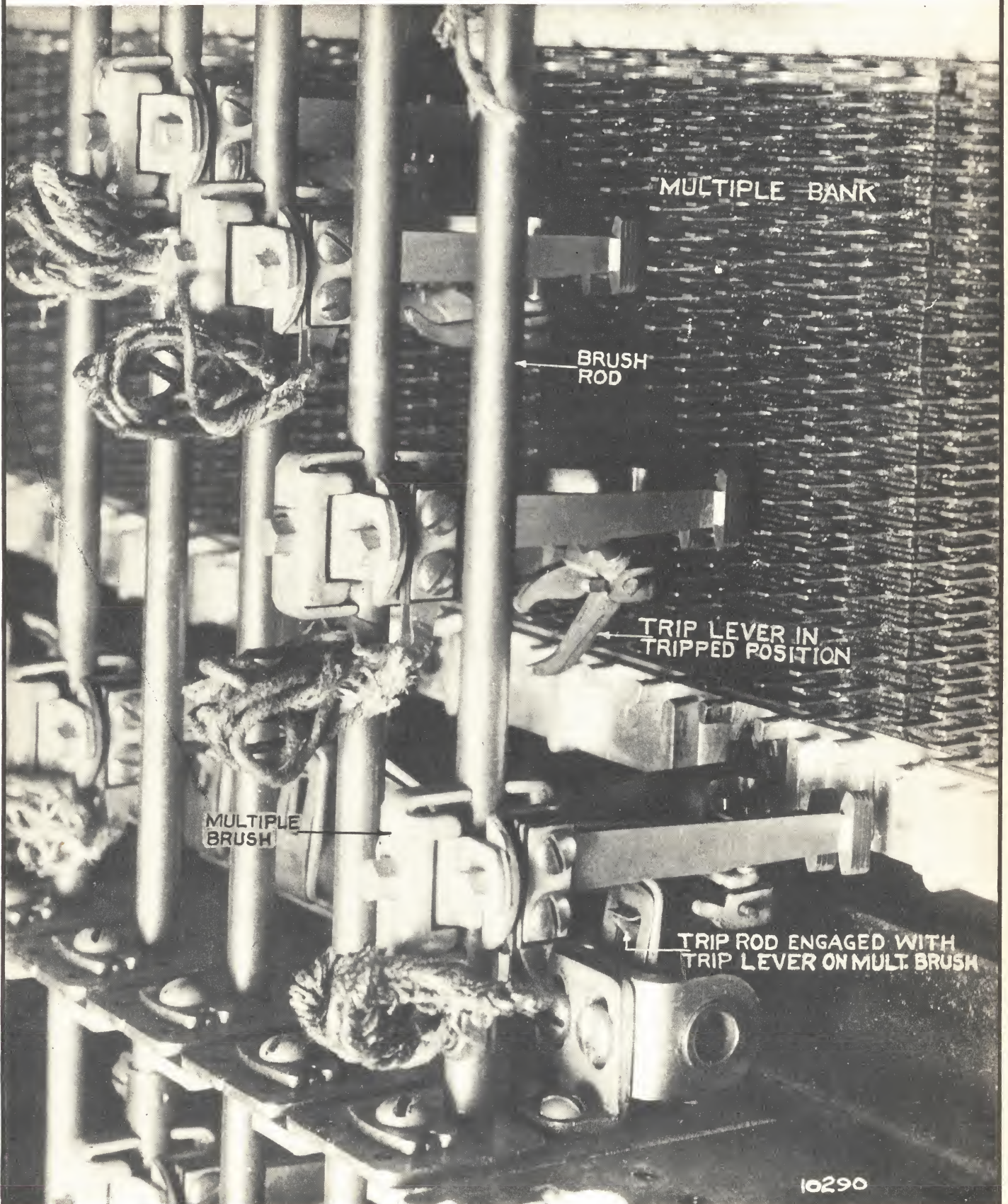

LINE FINDER BRUSH ROD & TRIP MECHANISM
FIG. 10

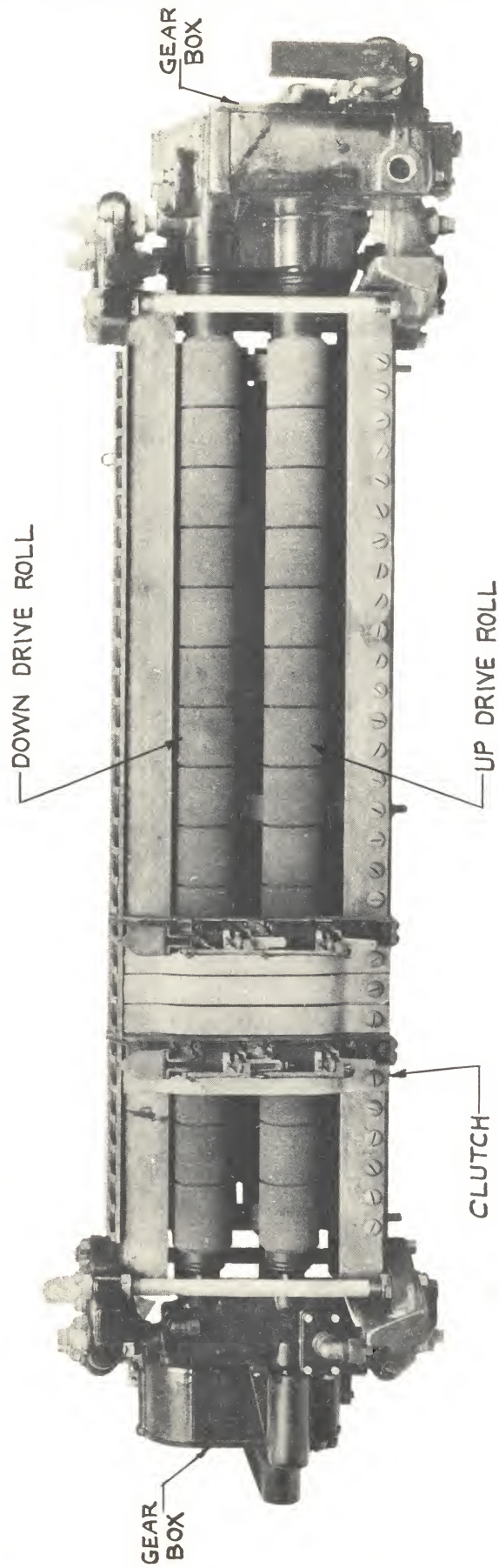

FRICTION ROLL DRIVE
FOR PANEL SELECTOR FRAMES
FIG. 11

PLATE 1
CONTRACT 7/105

FIG. 11
CONTRACT 7/105



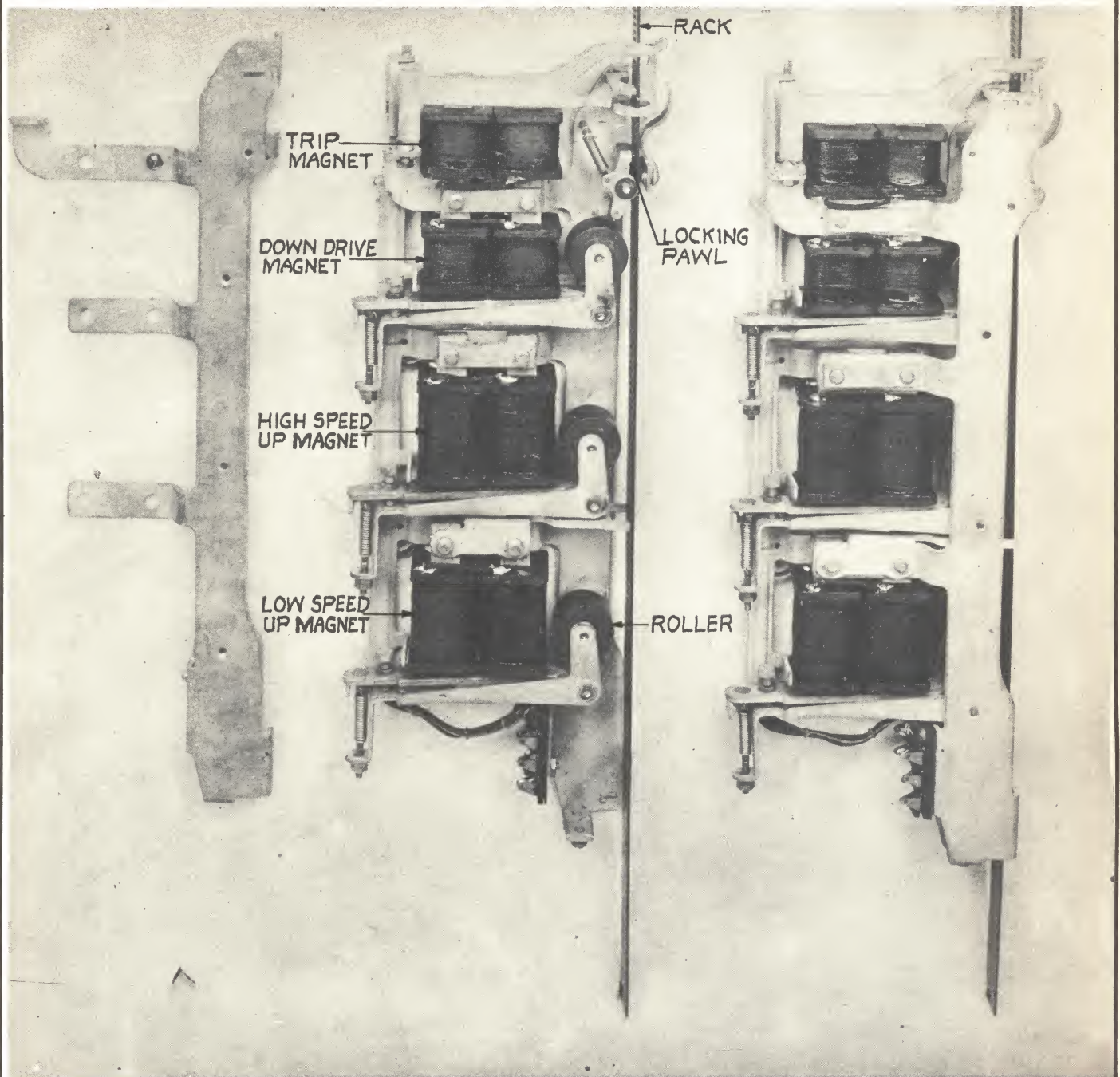

THE CLUTCH SHOWN IS A FINAL SELECTOR CLUTCH-THE LINE FINDER CLUTCH INCLUDES ONLY THE HIGH-SPEED UP MAGNET AND DOWN MAGNET-THE DISTRICT, OFFICE AND INCOMING SELECTOR CLUTCHES INCLUDE ONLY THE TRIP, HIGH-SPEED UP MAGNET, AND DOWN MAGNET

PANEL SELECTOR CLUTCH
FIG. 12

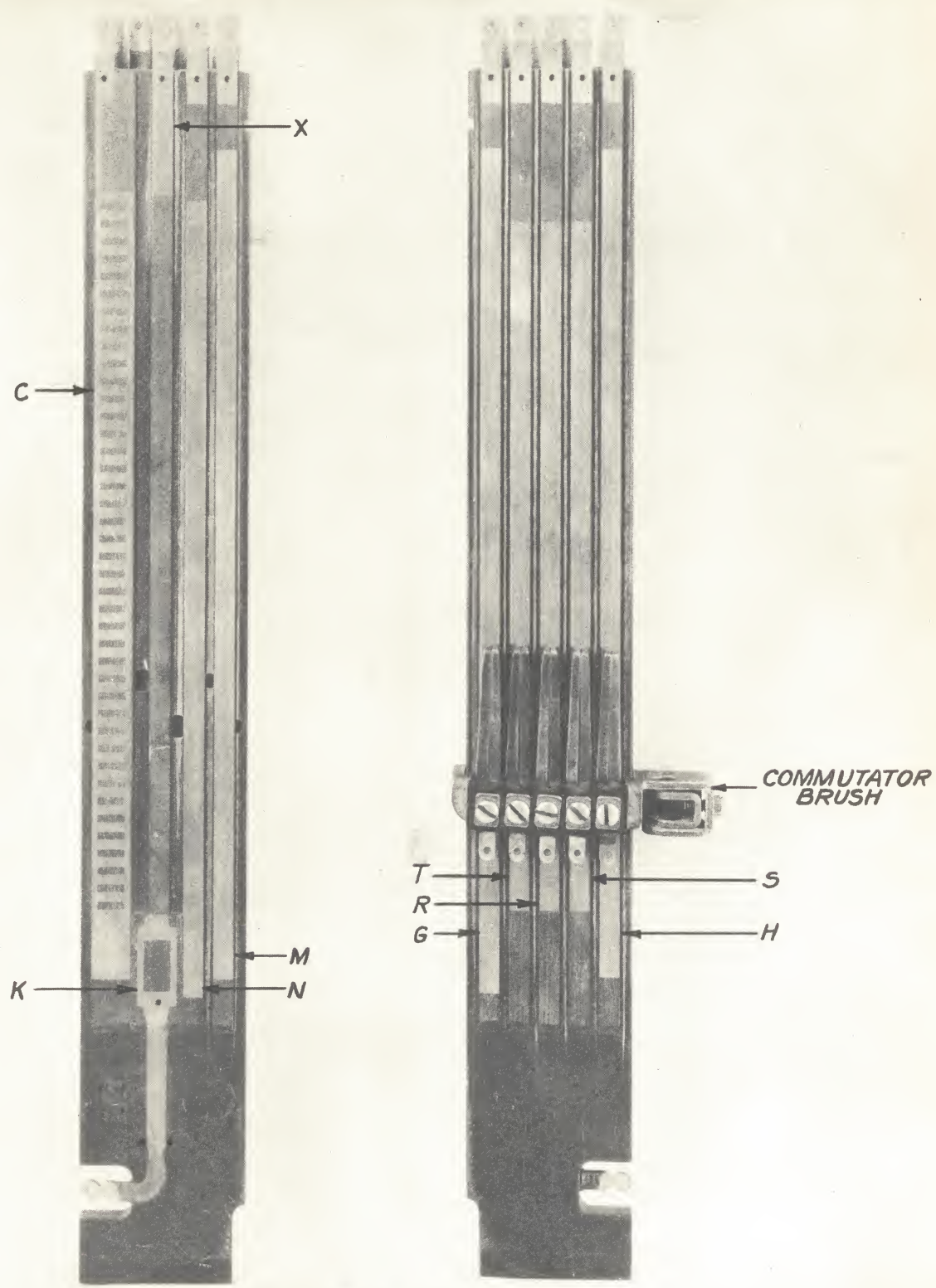

LINE FINDER COMMUTATOR - 5A

PANEL FRAME COMMUTATOR
FIG. 13

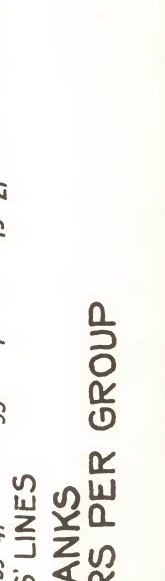
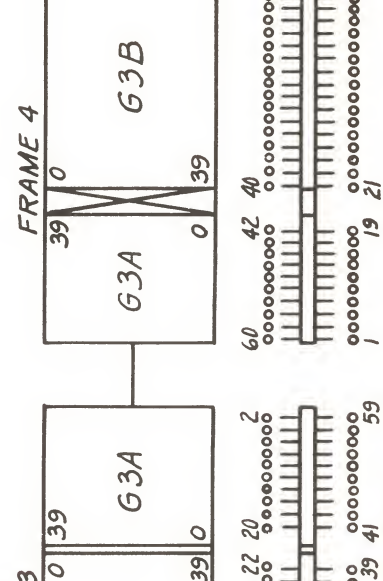
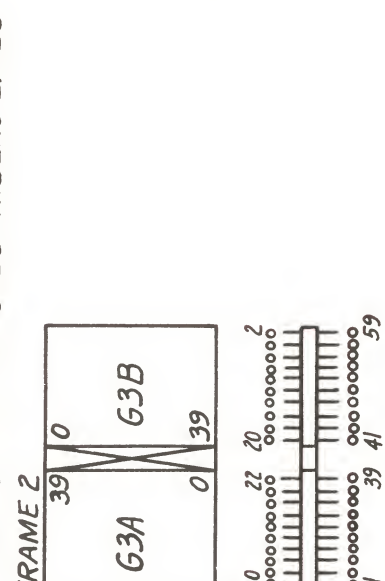
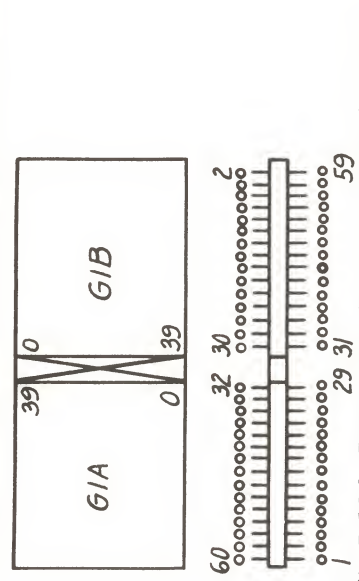

ARRANGEMENT OF MULTIPLE BANKS
 FOR 28, 40, 60, AND 80 LINE FINDERS PER GROUP
FIG. 14



MULTIPLE BANK
 TERMINALS



LETTERS IN SQUARES
 REPRESENT COMMUTATOR SEGMENTS

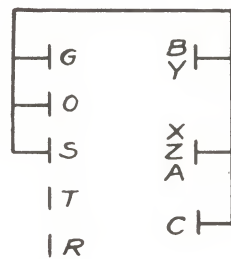

STRAPPING OF
 COMMUTATOR BRUSHES

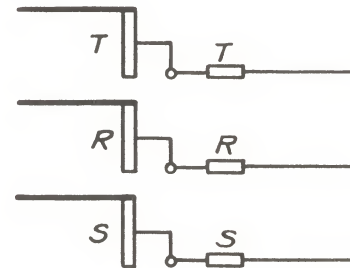

MULTIPLE AND COMMUTATOR
 BRUSHES



L.S.=LOW SPEED

H.S.=HIGH SPEED

CLUTCH MAGNETS

CIRCUIT CONVENTIONS
 FOR POWER DRIVEN SELECTORS
 FIG. 15

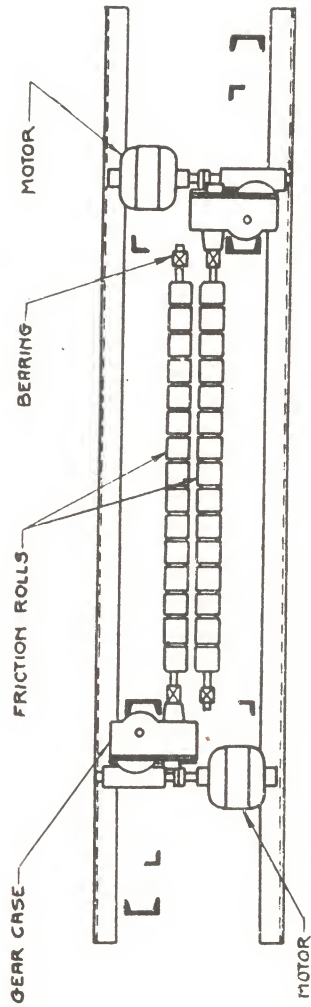

SINGLE UNIT MOTOR DRIVE

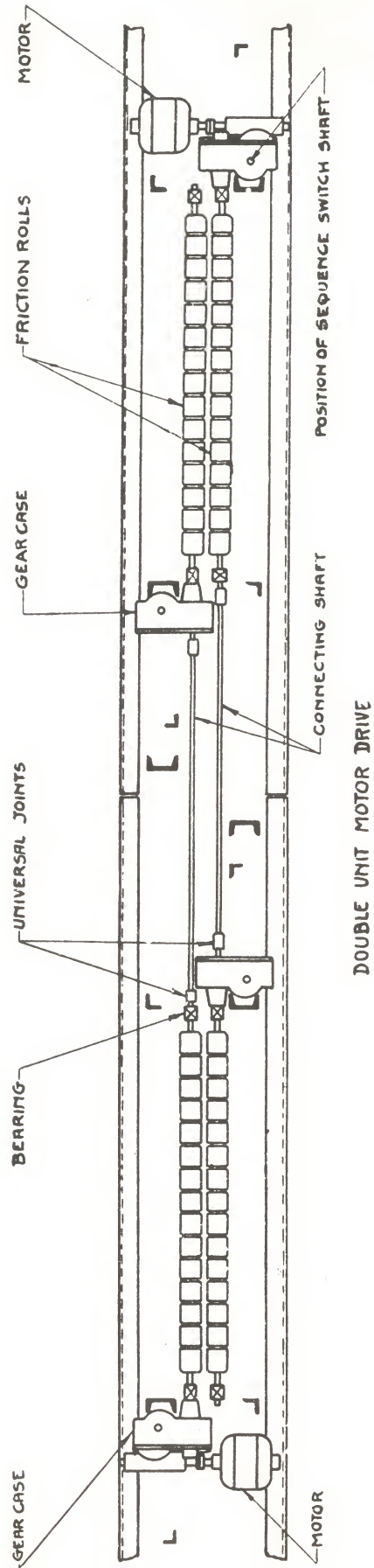

DOUBLE UNIT MOTOR DRIVE

SCHEMATIC LAYOUT OF PANEL TYPE FRAMES

FIG. 16

CHAPTER V

THE PANEL LINK FRAME

Before we can proceed with an explanation of the operation of a line finder we must first have a particular line finder selected for use on the call which we will later assume to be originated. We know that the calling line should be connected with the sender circuit as soon as possible after the subscriber removes the receiver from the hook so that he will not become impatient waiting for the dial tone and proceed with the dialing before it is possible for the dial pulses to be registered. The circuit unit which selects a particular line finder for use on an originating call and which also connects this line finder with an idle "sender" circuit is the "link" circuit. Two types of link circuits have been developed, the rotary and the panel. The apparatus which is to be described at this time is the "panel link". The apparatus consists essentially of a panel frame of the same general construction as a line finder frame on which are mounted two groups of brush rods with their associated clutches, brushes, commutators and commutator brushes. The brush rods in one group are called district finders, their function being to select an idle "line finder - district" circuit for use on the next call to be originated. The brush rods in the other group are called sender selectors, their function being to select an idle sender in which to register the number about to be dialed. With this general idea we will proceed with the description of the apparatus which is a part of and is used in the "panel link" circuit.

The assembly of a panel link frame is shown in Fig. 1 and the equipment mounted thereon is shown in Fig. 2. The frame consists of three bays, the center one of which contains a panel bank, clutches and brush rods. The bays at the end are used for sequence switches, relays, fuse panels, jack panels, etc. The frame has capacity for mounting 30 links, each link including two brush rods, a district finder and a sender selector. Facing the front of the frame the 15 brush rods on the right-hand half of the frame are the district finders of the odd numbered links, 1 to 29 and the 15 brush rods on the left-hand half of the frame are the sender selectors of these links, 1 to 29. Facing the rear of the frame the 15 brush rods at the right are district finders of the even numbered links, 2 to 30, and the 15 brush rods at the left are sender selectors of these links.

Two 100 point banks (100 sets of terminals, 3 terminals to a set) are used for the sender multiple. Each sender selector brush rod is equipped with two brushes, one for each bay. The brushes are made similar to the line finder brushes, the inner pair of springs making contact with opposite sides of the middle terminal in any set. The left inner spring on both brushes is used only to balance the tension between the two halves of the brush. The brushes are so spaced on the rod that when the lower brush is making contact with a set of three terminals in the lower bank, the upper brush is making contact with the correspondingly situated set of three terminals in the upper bank. A set of three terminals in one bank is thus combined with a set of three terminals in the other bank to make a set of six terminals through which the brushes make contact with T, TR, R, FT, SC, and FR leads from one sender. The six leads from each of 100 senders are in this way multiplied so as to be accessible to any one of the thirty sender selectors.

For cases where the traffic is such that the division between link circuits which hunt in one group of senders and those which hunt in another group of senders comes between links on the same frame, banks are provided in which the multiple is split vertically in the middle giving 15 links access to each sender group, or is split so as to give 10 links access to one sender group and the remaining 20 links access to the other sender group.

There is a brush rod bearing plate at the top of each bank for guiding the rod. In addition a vertical guide rod extends from the top of the lower bank to the top of the clutch mechanism just behind the brush rods and a fixture attached to the brush rod engages with and slides on this guide rod. The rack is slotted to correspond with the sets of multiple terminals, both the terminals and slots being on 1/8" centers. The clutch and driving mechanism are similar to those used in the line finder but there is no trip magnet or trip rod since the brushes are permanently tripped. The T, TR, R, FT, SC and FR multiple brush frames on each brush rod are connected by wiring carried within the rod to similarly designated springs on the commutator brush which make contact with and slide over metal segments on the commutator. These six commutator segments are connected through the local cabling to the cams on the sequence switch which belongs to the same link circuit. The commutator has three additional brush springs

designated "G", "Y" and "Z", and "C" and "X" there being commutator segments similarly designated. The commutators are attached to the frame just above the upper sender multiple bank. Stop collars on each brush rod limit the motion of the rod both upward and downward.

The multiple bank to whose terminal the leads from a group of line finder district circuits are connected is mounted in the central bay just above the sender selector commutators. This bank is of two sizes, the small of which has 44 terminals in each vertical row and the larger has 84 terminals in each vertical row. The vertical rows are grouped in sets of three and the multiple strips are stacked in sets of three. The smaller bank is used where there are 28 or 40 "line finder - districts" in a group, and the larger where there are 60 or 80 "line finder - districts" in a group. The district finder brush rods are each equipped with two brushes so spaced that when the lower brush makes contact with a set of terminals in the lower half of the bank the upper brush is making contact with the correspondingly located set of terminals in the upper half of the bank. The sets of 3 terminals each in the upper and lower halves of the bank are thus combined to make sets of six terminals each to which the six leads (T, TR, R, FT, SC and FR) from each line finder - district circuit are connected. The district finder brushes are permanently tripped and are otherwise similar to the sender selector multiple brushes. The district multiple bank is divided vertically, each terminal strip being divided into sections. There is one section for each pair of odd and one section for each pair of even numbered district finder brush rods and one additional section for the 15th finder on each side (#29 and #30). This arrangement permits the district finder and therefore the link circuit to be divided into groups as required to care for the traffic. The traffic originated by a sub-group of lines is handled by a sub-group of line finders. The sub-group of line finders is in turn served by a sub-group of link circuits. To care for the traffic originating thru the 14, 20, 30 and 40 line finder sub-groups the corresponding link sub-groups contain approximately 12, 14, 16, 20 and 24 links respectively, these numbers varying with the traffic in each particular case. Adjacent sections of multiple strips are strapped together to build up a link sub-group multiple to meet the traffic requirements.

The sequence switches which are associated with the odd numbered links

are mounted in the bay to the right of the odd numbered district finders and the sequence switches which are associated with the even numbered links are mounted in the bay to the right of the even numbered district finders. Below the sequence switches are mounted the key and lamp panels, jack panels and fuse panels. Above the sequence switches are mounted the link circuit relays.

The link frames are assigned in pairs, an A frame and a B frame. The district finders in a sub-group on the A frame hunt over the terminals of "line finder - districts" which belong to an A sub-group of line finders. The district finders in a sub-group on the B frame hunt over the terminals of "line finder - districts" which belong to a B sub-group of line finders. The link sub-groups are, therefore, numbered to correspond with the numbering of the line finder sub-groups. The odd numbered link sub-groups are generally placed on the front of the frame and the even numbered sub-groups on the rear. In locating the link frames on the floor it is desirable to arrange the frames in pairs so as to keep the links of a group in the same aisle. Six frames can be located in a line in many cases. Figure 3 shows the arrangement of link circuit sub-groups to correspond with the "line finder - district" sub-groups.

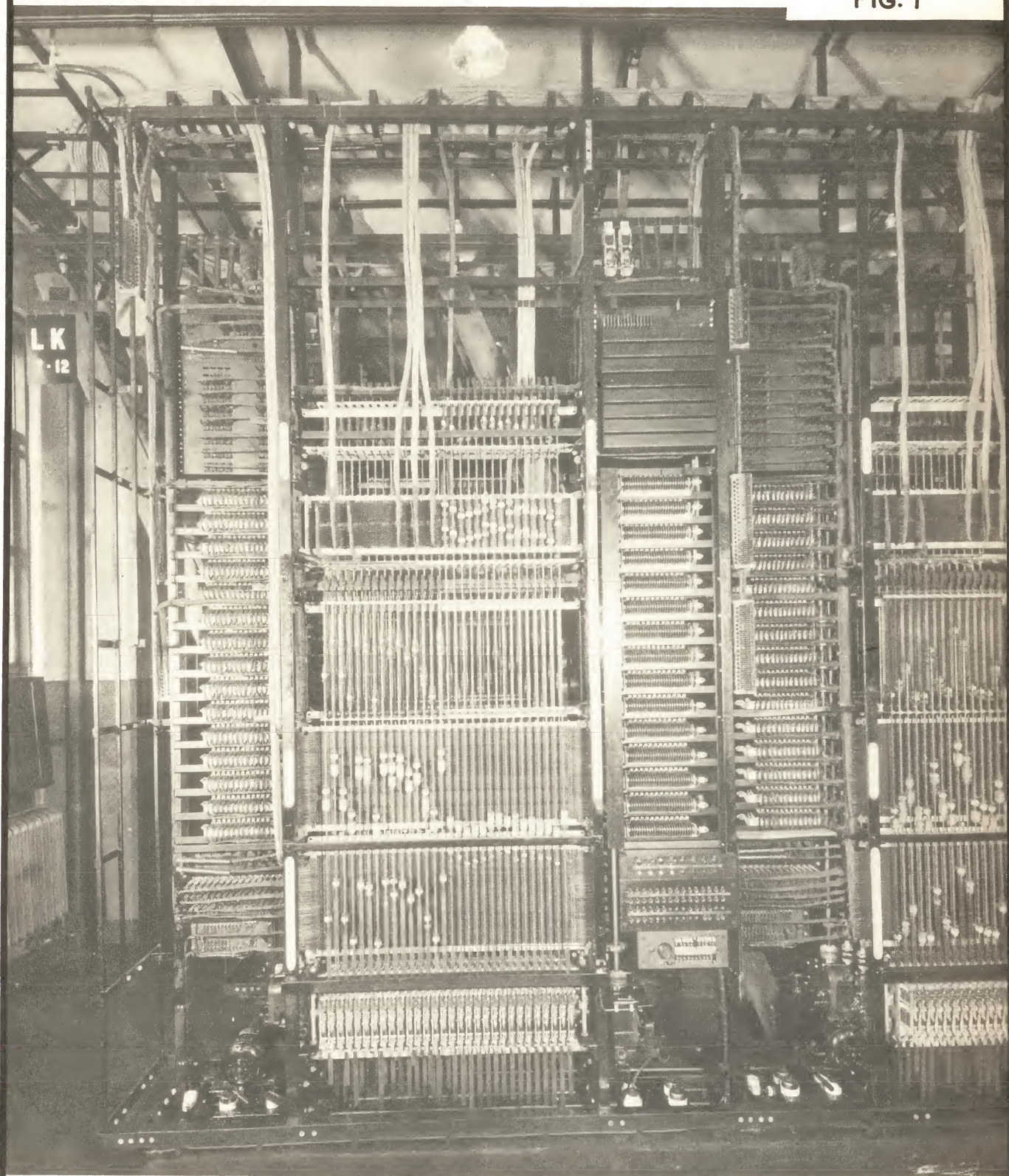

PANEL LINK FRAME
FIG. I

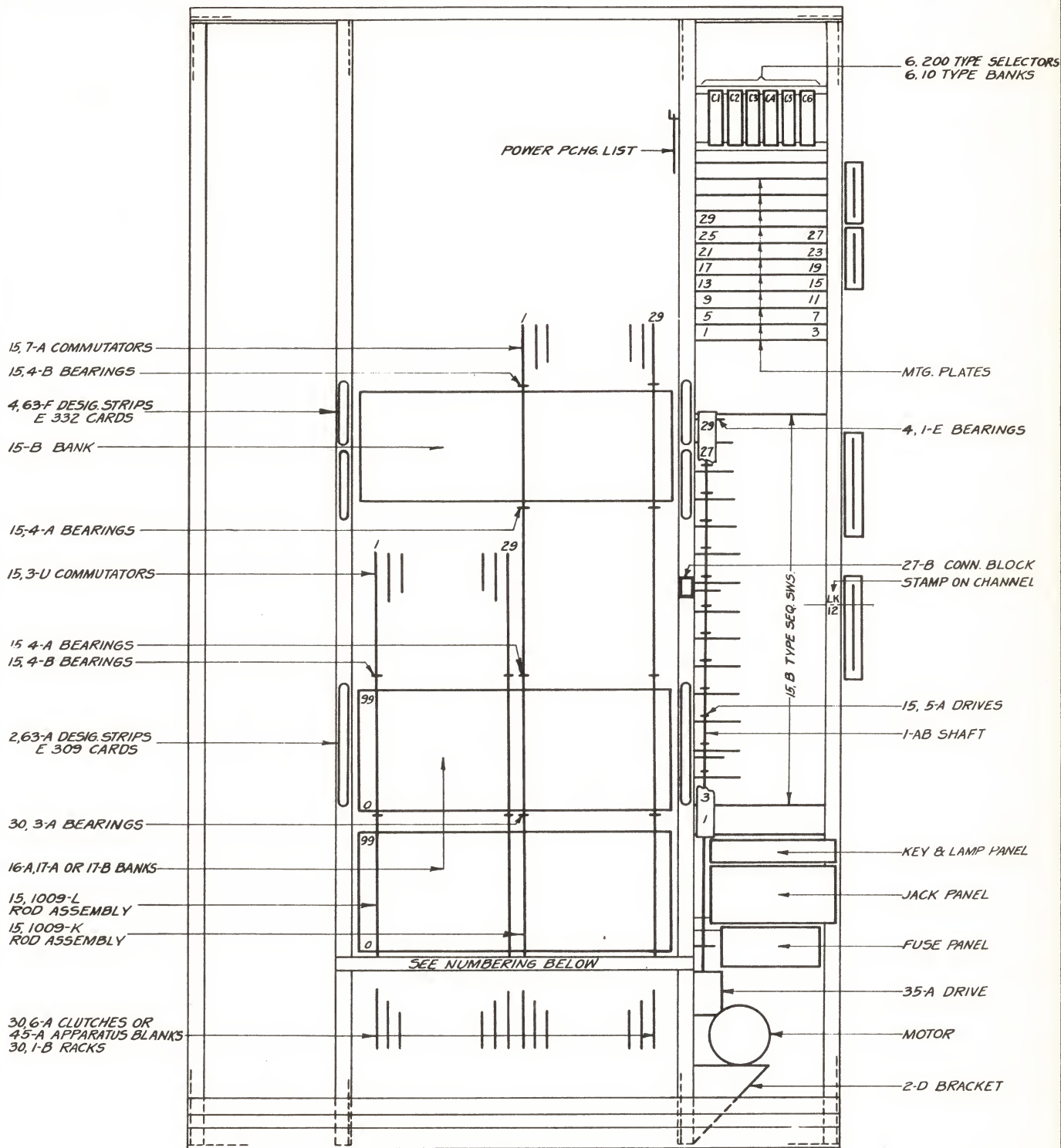

FRONT
EQUIPMENT ON REAR SAME AS ABOVE

1	3	5	7	9	11	13	15	17	19	21	23	25	27	29	1	3	5	7	9	11	13	15	17	19	21	23	25	27	29					
G-1A										SS					G-3A					G-1A					DF					G-3A				

NUMBERING ON FRONT CLUTCH RAIL

2	4	6	8	10	12	14	16	18	20	22	24	26	28	30	2	4	6	8	10	12	14	16	18	20	22	24	26	28	30
G-4A					SS					G-2A					G-4A					DF					G-3A				

NUMBERING ON REAR CLUTCH RAIL

LINK SUBSCRIBERS GROUP EQUIPMENT
FOR 60 OR 80 LINE FINDER GROUPS

FIG. 2

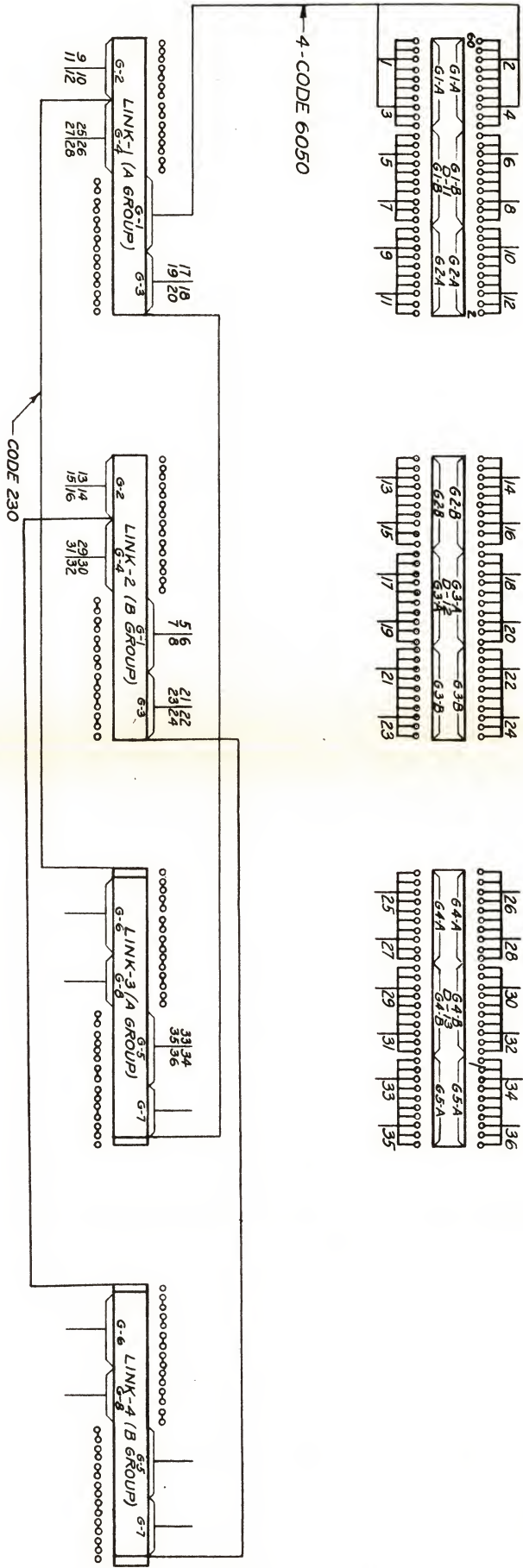

CABLING BETWEEN DISTRICT AND
 SUBSCRIBERS LINK FRAMES
 FIG. 3

CHAPTER VI

CONNECTING A CALLING LINE WITH AN IDLE SENDER CIRCUIT

We now have some conception of the equipment which is involved in connecting a calling subscriber's line to a sender circuit in which the called number is to be registered when dialed by the subscriber. We have not yet described the apparatus which goes to make up a sender circuit, nor how the senders are mounted on frames, and we will postpone that description until we are ready to register the number which is dialed.

A link circuit is a willing worker and as soon as it completes its cycle of operations on one call it proceeds to hunt for and connect itself to an idle "line finder - district" circuit so as to be ready for service when its next turn comes. When referring to a "line finder - district" circuit we may speak of it either as a line finder or as a district. Any district circuit which is not in use grounds a lead designated (ST) to the associated sub-group of link circuits, to notify them that there is one or more idle district circuits. The panel link hunting circuit is shown in Fig. 1. When a link has completed its service on a call its sequence switch is advanced to position 7, which is the hunting district position. The ground on the (ST) lead operates the (RL) relay in the link circuit. The (C) relay operates and the district finder UP magnet (D) is energized causing the district finder to move upward. The brushes make contact successively with the six terminals of the district circuits in the bank and when an idle district is reached a circuit is closed from battery through 270 ohms in the district circuit over lead (TR) operating the (T) relay in the link circuit. Operation of the (T) relay does not release the (C) relay until the brush rod has been driven upward far enough so that the "C" commutator brush breaks contact with a segment of the "C" commutator. The (C) relay then releases, the UP magnet releases, and the brush rod drops back so that the pawl in the clutch mechanism enters a slot in the brush rod rack, thereby centering the six brush springs on the six terminals of the idle district circuit. The "C" commutator brush and segments perform the function of making it certain that the brush rod is driven high enough after an idle terminal is found to allow the pawl to enter the corresponding slot in the rack (all trunk hunting power driven selectors have a "C" commutator brush and segments for a similar purpose). If

the finder travels to the top of the bank without finding an idle district the (SW) relay operates and locks, releasing the UP magnet. The DOWN magnet (D) is then energized and the brush rod moves down to the bottom of the bank in which position the "Y" commutator brush makes contact with the "Y" commutator segment and short-circuits and therefore releases the (SW) relay. The release of the (SW) relay opens the DOWN magnet circuit and closes the UP magnet circuit so that the brush rod is again moved upward and the idle district is found. The district finder and sender selector brush rods have no normal positions as do the power driven trunk hunting selectors. When the idle district is found the operation of the (T) relay short circuits its S wdg., holds thru its P wdg. and connects ground thru its P winding to the TR lead as a temporary busy condition. When the (T) relay operates the (RL) relay releases thus causing the advance of the link sequence switch to position 8, which is the "awaiting district" position. In position 8 with the (T) relay operated, ground is connected over the T lead to the district, operating the district (L) relay and thus advancing the district switch to position 2, "awaiting call". This advance of the district switch releases the district (L) relay and opens the (TR) lead so that the (T) relay in the link circuit releases. The opening of the (TR) lead also prevents any other link which is hunting for an idle district circuit from selecting this same district. The release of the (T) relay advances the link switch to the "awaiting allotment" position.

The link circuits in a sub-group are used in rotation and there can be but one link in the "awaiting call" position at a time, all other idle links remaining in the "awaiting allotment" position. When a link which has been waiting for a call to be originated moves out of the "awaiting call" position the preceding link in the sub-group is allotted, that is, advanced out of the "awaiting allotment" position into the "awaiting call" position. If all links in the sub-group are awaiting allotment, the last link is allotted for use on the next call. The link which we have mentioned as being the last link does not derive this designation from the order in which it is allotted, but from the order in which the lead from the start circuit connects to and loops through the chain of links in a sub-group. Figure 2 shows the link allotting circuit and is self-explanatory.

Assume that the link whose operation we are following is advanced from the "awaiting allotment" position to the "awaiting call" position. We now have a link connected with an idle district circuit, both of them in the "awaiting call" position at the time that a subscriber whose line is in an A sub-group removes the receiver from the hook. Figure 3 shows schematically the circuits involved in connecting a calling subscriber's line with an idle sender circuit. When the receiver is removed from the hook the (L) relay in the line circuit operates, connecting battery through a 500 ohm resistance in parallel with the 500 ohm winding of the (R) relay to the "H" terminal strip associated with this line in one of the line finder multiple banks. The operation of the (L) relay operates the (A) relay in the trip circuit. The (A) relay operated, operates the (AL) and (TR) relays. The (TR) relay locks through its (P) winding, operates the (ST) relay in the start circuit and operates the trip magnets which are associated with the group of lines in which the subscriber's line terminates. The (D) relay operates and locks under control of the (R) relay, thereby causing operation of the (FLA) relay and connecting ground over the (STA) lead to the (A) sub-group of links which are associated with the line finders of the frame on which this subscriber's line terminates. (If all of the links were busy in sub-group (A), this ground would be connected over the (STB) lead instead of the (STA) lead to the (B) sub-group of links.) This ground on the (STA) lead is connected through the chain of links in the sub-group to that link which is awaiting a call, and through that link to the "line finder - district" circuit causing the operation of the (LF) relay. The (LF) relay locks under control of the (H) relay to ground through the "N" commutator. Operation of the (LF) relay closes the line finder UP magnet circuit and connects ground to the FR lead. This ground operates the (GA) relay in the start circuit and the (SW) relay in the link circuit. The (GA) relay operated, opens the (STA) lead, releases the (FLA) relay and holds the (ST) relay operated. The operation of the (SW) relay advances the link switch to position 2, "hunting sender". When the link advances, the district (L) relay operates and locks in position 2. The GA lead is opened when the link advances but the (GA) relay holds under the control of the (TR) relay. The (GA) relay also holds the (ST) relay operated so as to prevent another call from being started. Since the switch magnets are energized when the

brush rod is driven upward, the multiple brushes associated with the bank in which the calling line terminates are tripped so that the brush springs make contact with the line terminals. When the line finder brush rod has travelled upward beyond the tripping zone the K commutator brush makes contact with the K segment holding the (ST) relay but short circuiting and releasing the (TR) relay. The release of the (TR) relay releases the trip magnets and the (GA) relay. The (ST) relay releases as soon as the brush rod has travelled high enough so that the K commutator brush breaks contact with the K segment. Another line finder can be started as soon as the (ST) relay releases on a call from any of the other lines on the frame. When the line finder brushes make contact with the terminals of the calling line the (H) relay operates releasing the (LF) relay. The trip circuit (R) relay then operates and holds thru its S winding until the (D) and (LO) relays release. The (D) relay is slow in releasing so that on an overthrow of the line finder brushes the (R) relay is held operated so as to prevent the starting of a second line finder on the same call before the brushes of the first have settled back on the terminals of the calling line. The line (CO) relay is operated from battery thru 220 ohms in the line finder circuit over the S lead. Operation of the (CO) relay releases the line (L) relay. The release of the line (L) relay releases the (A) and (R) relays in the trip circuit and releases the (H) relay in the line finder circuit. With the district (L) relay operated as previously described the release of the (LF) relay advances the district switch to position 3 "awaiting sender". The district (L) relay releases when the switch advances.

We now have the calling line connected to a line finder circuit and, thru this line finder, to a link circuit. This link has in the meantime been hunting for and connecting itself to an idle sender circuit. Figure 1 shows the sender hunting circuit, the operation being practically identical with that of the district hunting circuit. When the (RL) relay releases after an idle sender has been found, the link switch is advanced to position 3, "awaiting sender". This advance closes the SC lead from the sender to the district circuit, which is also in the "awaiting sender" position.

When the selected sender is one of the last ten (or twenty if so desired) at the top of the bank a circuit is closed thru the Z commutator which

causes the sender selector to return to the bottom of the frame at the end of the call instead of remaining on that set of terminals until the link is advanced to the hunting sender position on a succeeding call. This is done to avoid as far as possible delaying the selection of a sender by waiting for the selector to be driven from the top to the bottom of the frame during hunting. The closure of the (SC) lead operates the district and sender (SC) relays but does not operate the district (D) relay. Operation of the sender (SC) relay operates the (SC1), (H1) and (SB) relays. The (SB) relay operated, opens the (TR) lead, releasing the link (T) relay and preventing selection of this sender by any other link. The release of the link circuit (T) relay advances the link switch to position 5, "cut through", in which all of the six leads except the (TR) lead are connected through from the district to the sender, and the link remains in this position until the sender has completed its functions and is dismissed by the district. We now have the calling subscriber's line connected to a sender circuit and the subscriber is waiting for a dial tone. Before we have the dial tone transmitted by the sender circuit we should learn something more about the sender circuit and the apparatus of which it consists.

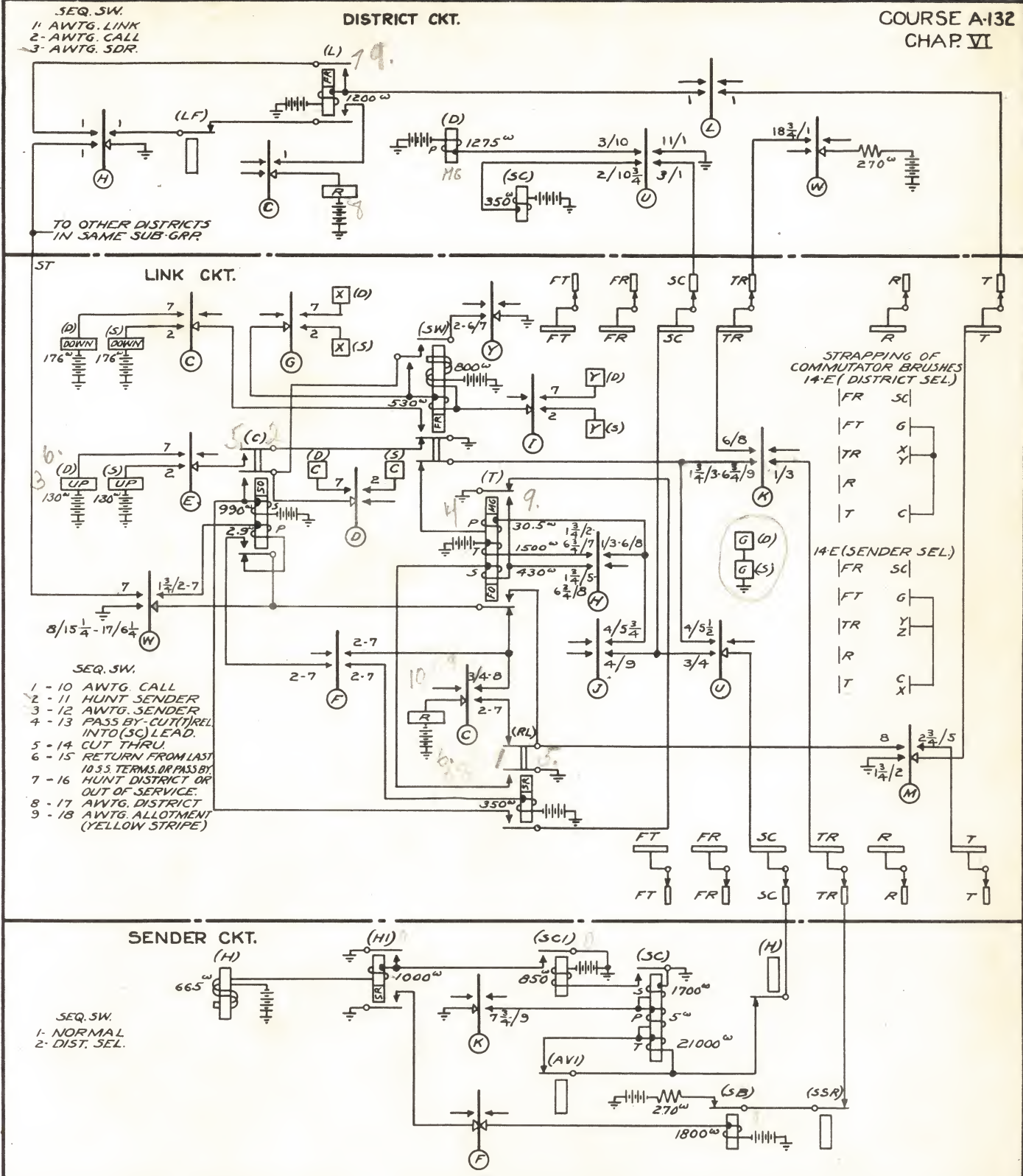

PANEL LINK HUNTING CIRCUIT
 FIG. I

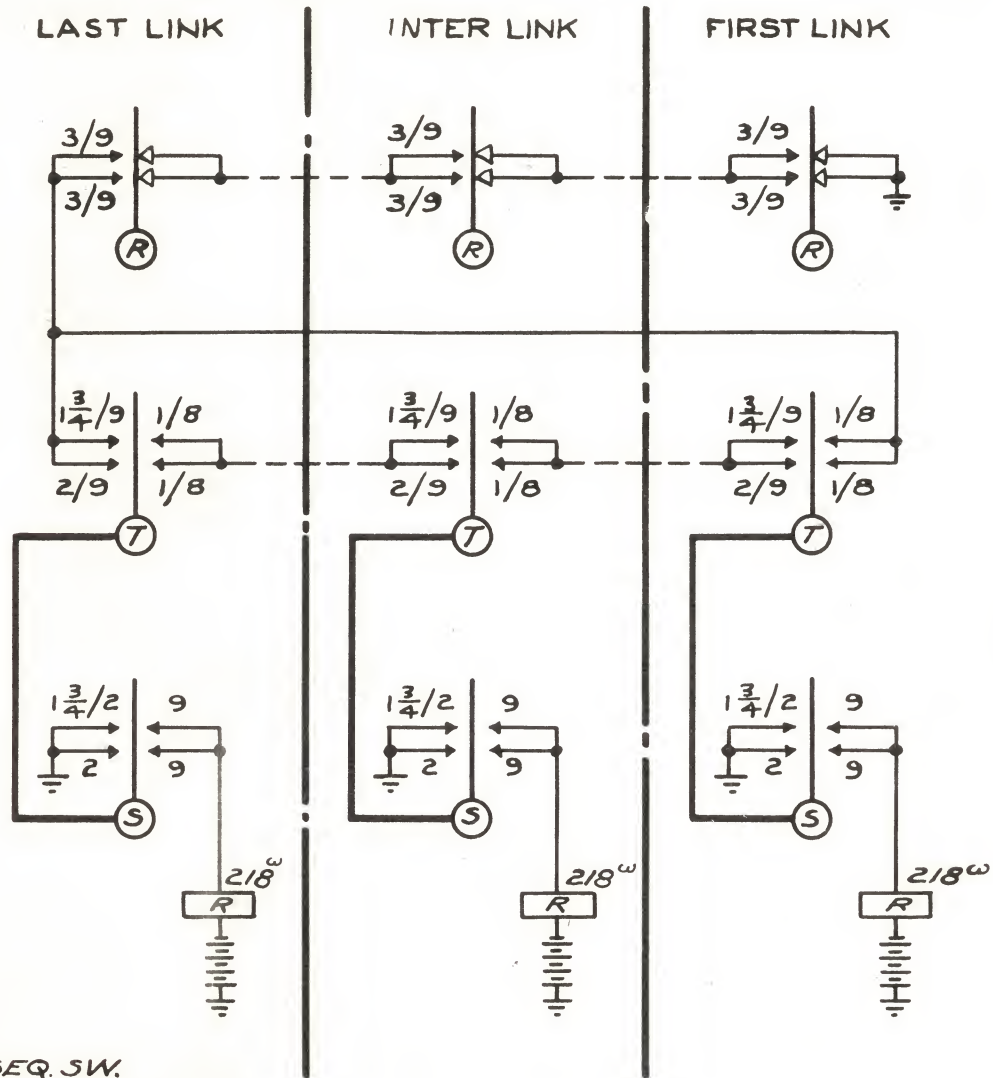

SEQ. SW.

- 1-10 AWTG. CALL
- 2-11 HUNT SENDER
- 3-12 AWTG. SENDER
- 4-13 PASS BY- CUT(T)REL. INTO(SC) LEAD.
- 5-14 CUT THRU
- 6-15 RETURN FROM LAST 10 SS TERMS. OR PASS BY
- 7-16 HUNT DISTRICT OR OUT OF SERVICE
- 8-17 AWTG. DISTRICT
- 9-18 AWTG. ALLOTMENT (YELLOW STRIPE)

PANEL LINK ALLOTING CIRCUIT

FIG. 2



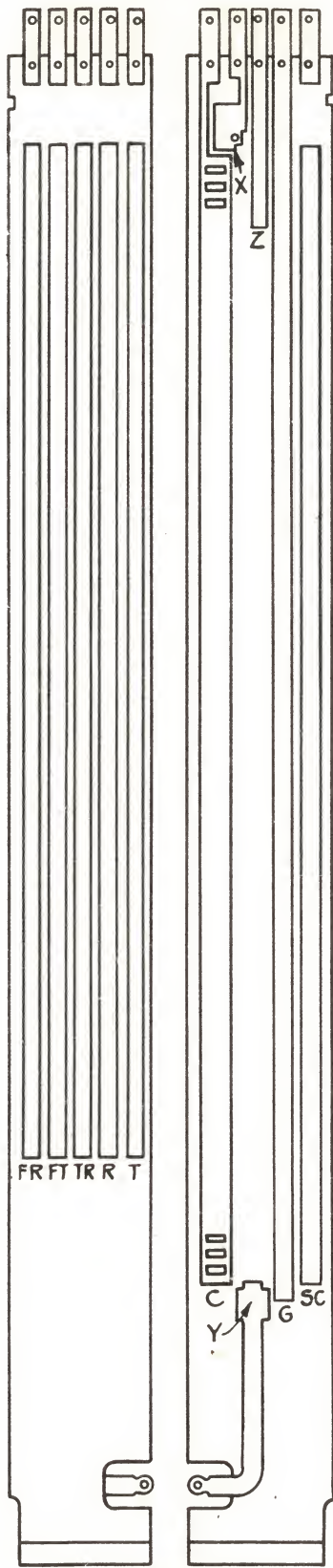

3-U COMMUTATOR
SENDER SELECTOR
LINK

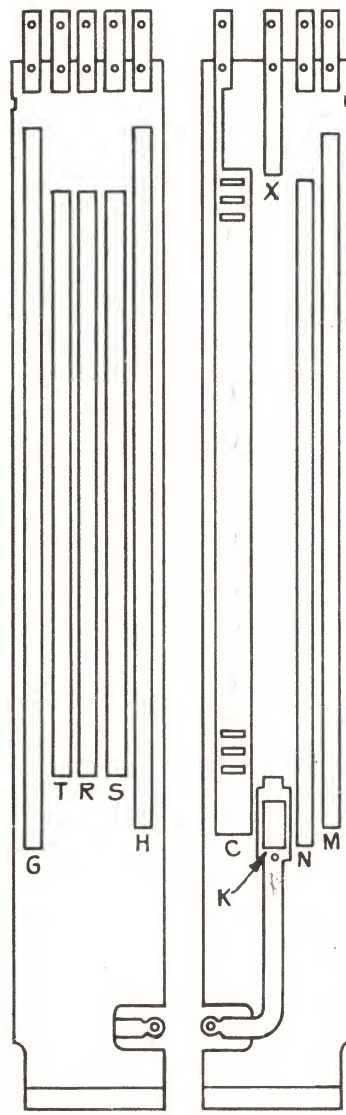

5-A COMMUTATOR
LINE FINDER

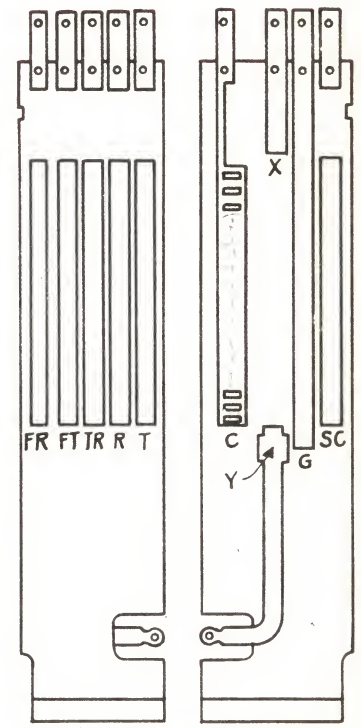

6-A COMMUTATOR
DISTRICT FINDER
LINK

LINE FINDER AND LINK COMMUTATORS
FIG. 4

CHAPTER VII

SUBSCRIBER'S SENDERS - APPARATUS AND FRAME

In the analogy between panel system and manual system operation in the first chapter of these notes we found that the sender circuit was the brains of the system, for it told subscribers when to dial, it registered the numbers that the subscriber dialed, and it went through a process called "Translation" whereby it decided what control it must exercise over the various selective mechanisms in order that the connection be properly completed. The necessary control was then exercised and an idle trunk to the office in which the called line terminates was selected. Finally the called line itself was selected and the sender then caused the selector mechanisms to connect the calling line with the called line. Since its services were no longer required the sender returned to normal in order that it might be used on another call.

The sender is, therefore, composed of pieces of apparatus which operate to fulfill these functions. Every sender circuit consists of a number of relays, condensers, resistances, sequence switches, registers, and the "translator" mechanism.

A two-digit sender circuit contains four sequence switches, - a sender control switch, a sender switch, a class switch, and an RCI impulse switch, designated (R-1), (R-2), (R-3) and (R-4) respectively. The various switches control the circuit conditions in the sender during completion of a call as follows

- (a) The sender control switch, (R-1), controls the seizure of the sender and the return of the sender to normal.
- (b) The sender switch, (R-2), controls district selections, trunk test, numerical selections on mechanical calls, and the start of RCI pulses on RCI class calls.
- (c) The class switch, (R-3), causes the sender to function as required for completing the various classes of calls. By class of call we mean whether the call goes directly to a subscriber in another panel type office, directly to a subscriber in a manual office, whether it is completed thru a tandem office, or whether it goes to a toll, information or special operator. In each of these cases, the sender

must function differently. The class switch has no normal position and remains in one position until a succeeding call requires that it be set in a different position.

- (d) The RCI impulse switch, (R-4) establishes the circuit conditions required for sending RCI impulses to manual or tandem offices. The switch makes two revolutions on each RCI call.

The two-digit sender contains nine 200 type selectors designated the register control (RC) switch, office code registers (A) and (B), the numerical registers (TH), (H), (T), (U) and (STA) and the time measure switch (M). The three-digit sender has an additional 200 type selector for the office code register (C). The use of these selectors is as follows:

- (a) The register control (RC) switch directs the impulses from the calling subscriber's dial to the office code and numerical registers in proper sequence. The register control switch also prevents an attempt to make any selection before the registers which control this selection have been set.
- (b) The office-code registers control the setting of the "translator".
- (c) The numerical registers control incoming and final selections on mechanical class calls and control the circuit conditions established for sending RCI impulses on RCI class calls.
- (d) The time measure and alarm (M) switch measures the time allowed the sender for performing its several functions and if a given part of the sender's operation has not been completed in this measured time a signal is displayed at an operator's position.

The translator mechanism for a two digit sender consists of two, or four 1203 type selectors which are mounted on the same frame with the sender. The translation of the setting of the office code and numerical registers in a 3 digit sender is performed by a decoder or a power driven selector on a separate frame, called a translator frame, in connection with a motor driven pulse machine. The description of the apparatus used for translation will be made later when translation itself is explained.

The 200 type selector which will now be described (shown in figure 1) is a step-by-step rotary switch which has facilities for controlling six separate circuits. It is composed essentially of a brush assembly, stepping magnet, and a semi-circular bank of terminals. The bank consists of six rows of 22 terminals each mounted radially in a semi-circular mounting which is concentric with the brush assembly shaft. The terminals extend through the mounting, the projections on the inner surface providing wiping contact for the brushes, and those on the outer surface forming soldering lugs. The first terminal in each row is used for making connection with the corresponding brush and for that purpose the inner projection is extended in the form of a flat spring which forks out on each side of the shaft so as to rest on a slip ring portion of the brush. Each contact brush is composed of two flat springs so formed that they rest on opposite sides of any terminal with which they are making contact. Around the shaft the springs form the slip ring with which the brush feed terminal springs make contact. The brushes are double ended so that when one end of the brush is advanced a step from the last terminal the other end of the brush makes contact with the first of the 22 terminals. Brushes may be bridging or non-bridging. The non-bridging brush makes contact with one terminal before it breaks contact with the next, and a bridging brush makes contact with a terminal before it breaks contact with the preceding terminal. A non-bridging brush cannot be depended upon not to bridge nor can a bridging brush be depended upon to bridge.

The stepping mechanism consists of a ratchet wheel mounted on the brush assembly shaft the teeth being spaced so as to correspond with the multiple bank terminals. A stepping magnet is mounted on the same frame which furnishes the bearing for supporting the shaft of the brush assembly. To the armature of the stepping magnet is attached a spring pawl which engages the ratchet. Each time the magnet operates the pawl is advanced one step and when the magnet releases a coiled spring pulls the armature back to its normal position, and in so doing the pawl pushes the brush assembly around one step. A set of contact springs on the magnet may be used so as to open the magnetizing circuit each time the magnet operates and thus continue stepping the brushes ahead until the circuit is opened at some other point. The multiple bank mounting fastens to the framework on which the selectors are to be mounted, and the frame which supports the stepping magnet and brush assembly is fastened to the multiple bank mounting

by two machine screws. This arrangement makes the brush assembly and stepping magnet readily removable both for shipping and maintenance purposes and it also makes it possible to provide ultimate multiple bank space without initially providing the magnets and brushes.

The register and register control switches have two normal positions, spaced 10 terminals apart; the normal terminal is designated N and each set of 10 terminals are numbered from 1 to 0. The time measure switch has but one normal position and its terminals are numbered from 1 to 21. An attached sketch shows the conventions used on circuit drawings to represent a 200 type selector.

On some of the earlier panel type installations the 200 type selector was used as a line switch, for connecting the line to an idle district circuit, and as a sender selector for connecting a district selector to an idle sender circuit. The line switch and sender selector use one brush and arc of terminals for hunting an idle circuit. The line switch connects the T and R leads from the calling line to the T and R leads from the district selector and the sender selector, (which is part of the district selector circuit) connects the T, R, FT, SC, and FR leads from the district to the sender.

On the latest sender frames the senders are mounted as units on a single sided steel framework, there being six senders per frame in both two and three digit offices. At one time only 5 senders were mounted on a unit type frame and originally sender frames were not of the unit type, that is all of the apparatus belonging to one sender circuit was not mounted together on a framework as a unit. Each unit type frame is equipped with one interrupter unit which is common to the six sender circuits. The three digit sender frame is divided into three bays: the left-hand bay for mounting sequence switches and interrupters; the middle bay for mounting relays, terminal strips and the drive motor; the right-hand bay for mounting the 200 type selectors.

The two digit sender frame, arranged for 44 office codes, is divided into four bays, while that for 88 office code is divided into five bays. The first bay on the right hand side is used for mounting the 200 type selectors; the second from the right mounts the relays and resistances; the third bay from the right mounts the sequence switches, interrupters and drive motor; and the remaining bay or bays are used for mounting the 1203 type power driven rotary selectors and terminal strips. The relay portion of the sender units are arranged

for enclosure in a metal dust-proof casing.

The sender circuits are cabled from the terminal strips on the sender frame directly to the sender multiple on the link frames. A full group of 100 senders is multiplied on from 12 to 16 link frames, (approximately) according to traffic.

The two and three digit sender frame and unit assemblies are shown in sketches attached. Other sketches show the cabling between subscribers links and sender frames and the local cabling on a three digit sender frame.

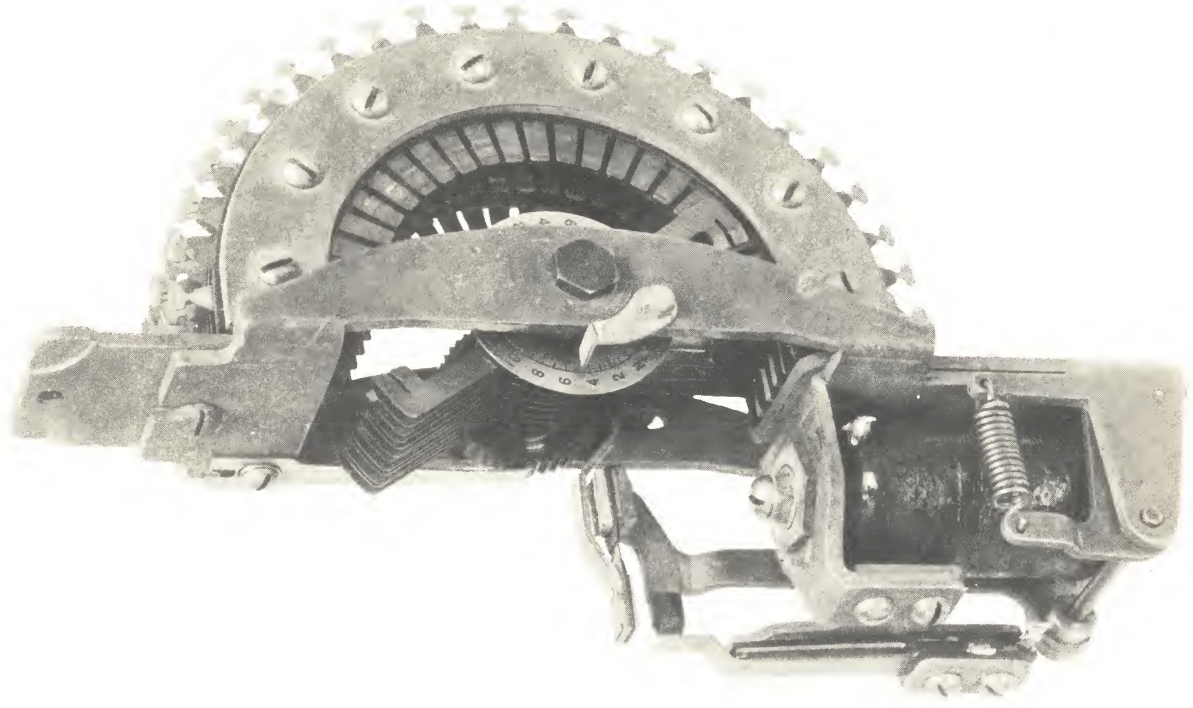

CIRCUIT DESIGNATION
OF SELECTOR

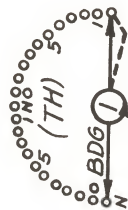
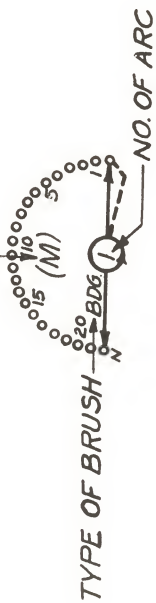

TYPICAL CIRCUIT CONVENTIONS OF ARCS
SHOWING TYPICAL NUMBERING

CIRCUIT DESIGNATION
OF SELECTOR



TYPICAL CIRCUIT CONVENTION OF MAGNET

200 TYPE SELECTOR
FIG. 1

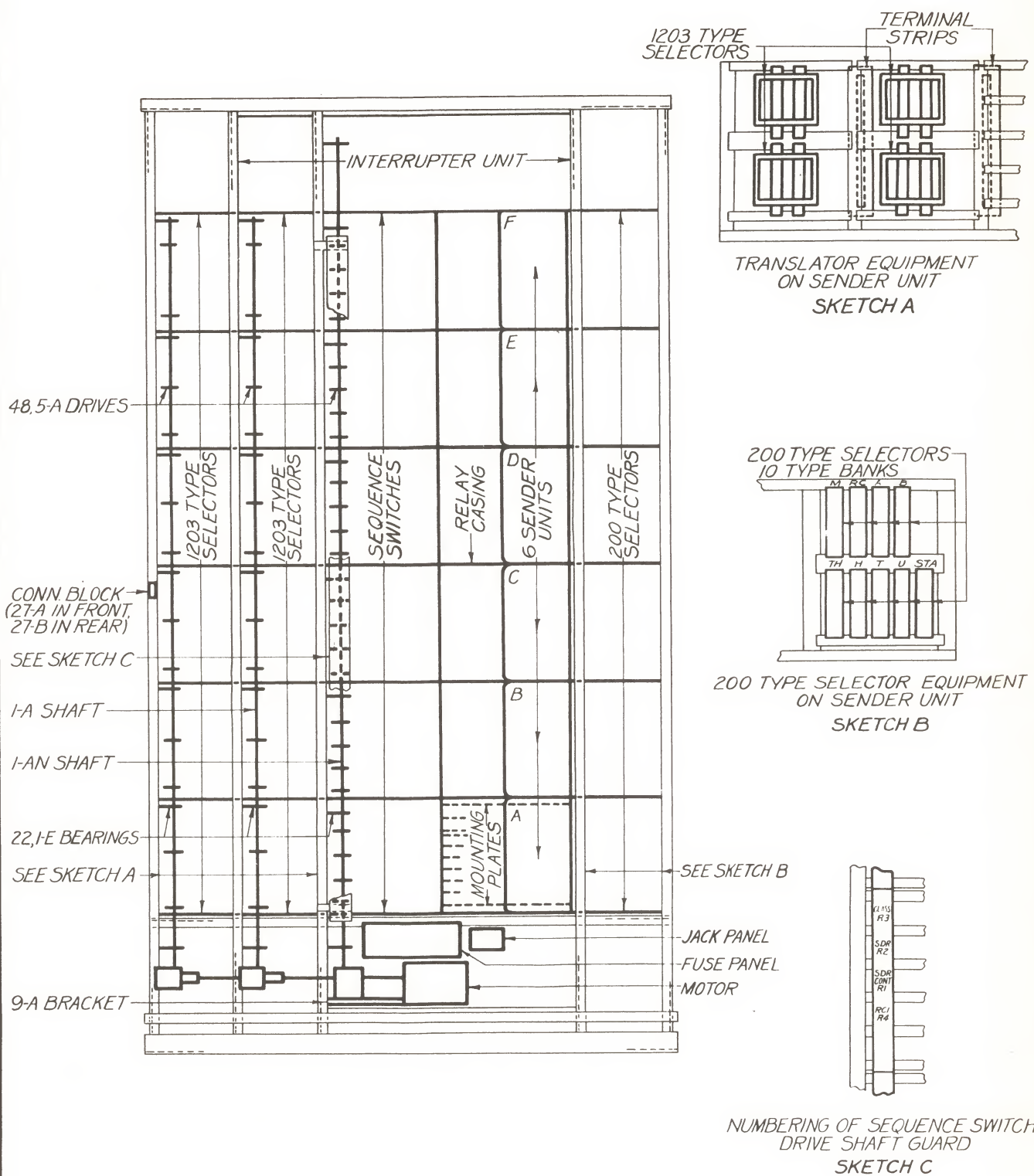

SUBSCRIBERS SENDER FRAME
 2 DIGIT-UNIT TYPE
 WITH 88 POINT TRANSLATOR
 FIG. 2

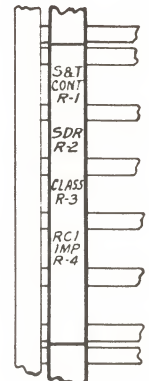
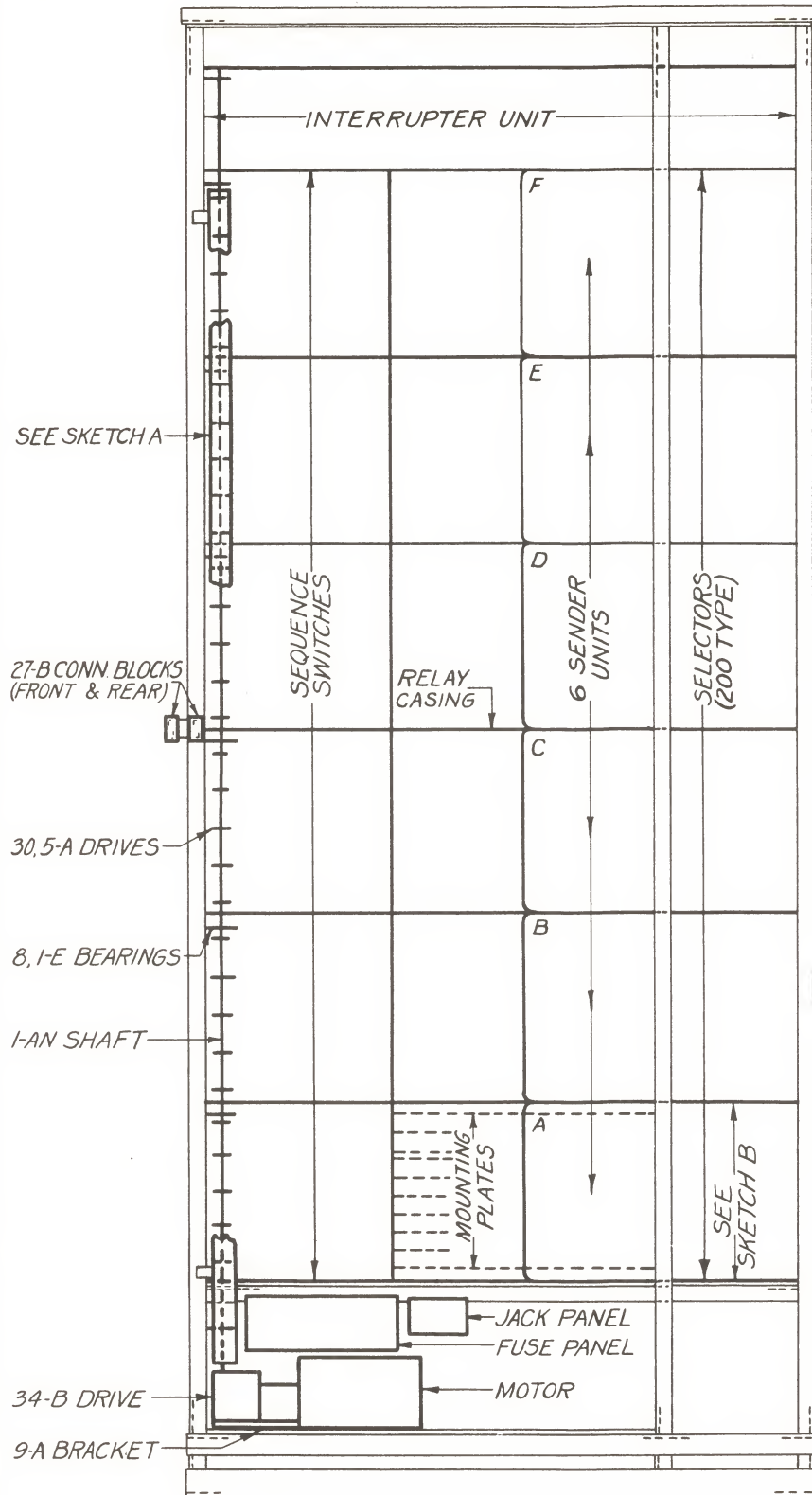

NUMBERING OF SEQUENCE SWITCH
 DRIVE SHAFT GUARD
 SKETCH A

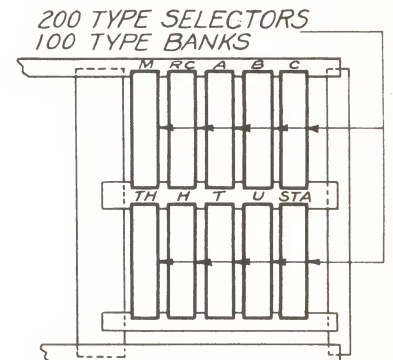

SELECTOR EQUIPMENT
 ON SENDER UNIT
 SKETCH B

SUBSCRIBERS SENDER FRAME
 3 DIGIT-UNIT TYPE
 FIG.3

SUBSCRIBER'S SENDER FRAME
3 DIGIT-NON-UNIT TYPE
USING PULSE MACHINE TRANSLATION
FIG. 5

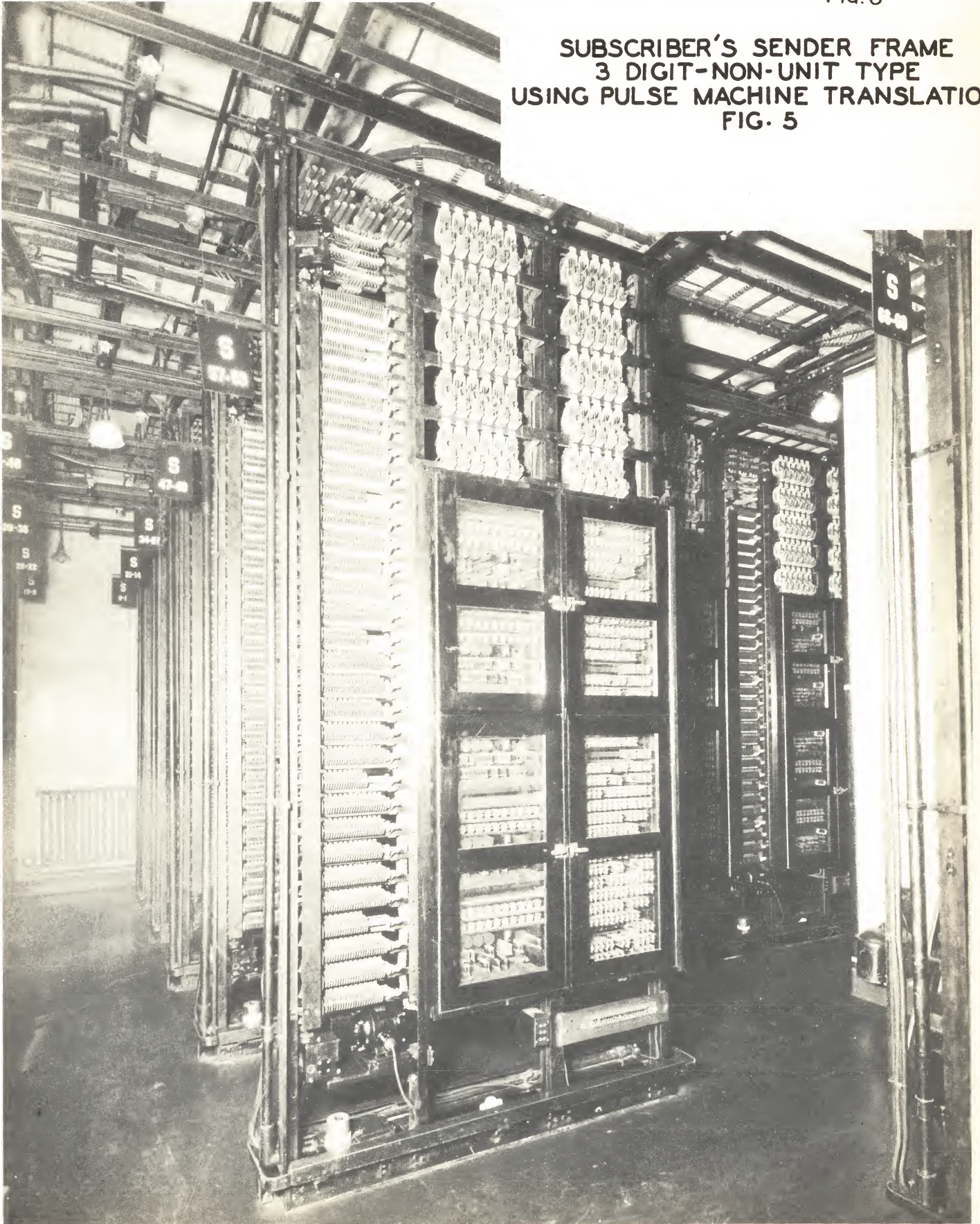

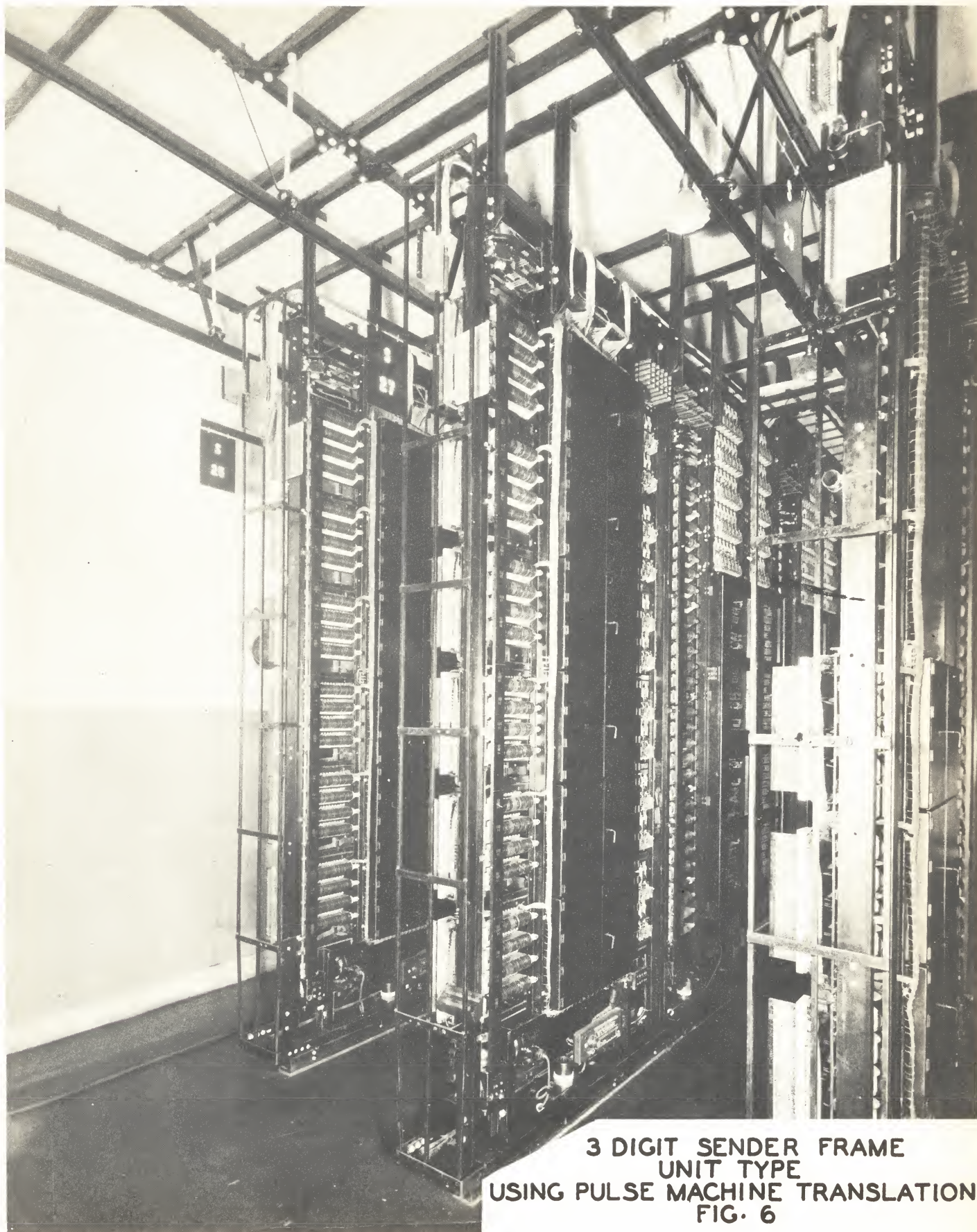

3 DIGIT SENDER FRAME
UNIT TYPE
USING PULSE MACHINE TRANSLATION
FIG. 6

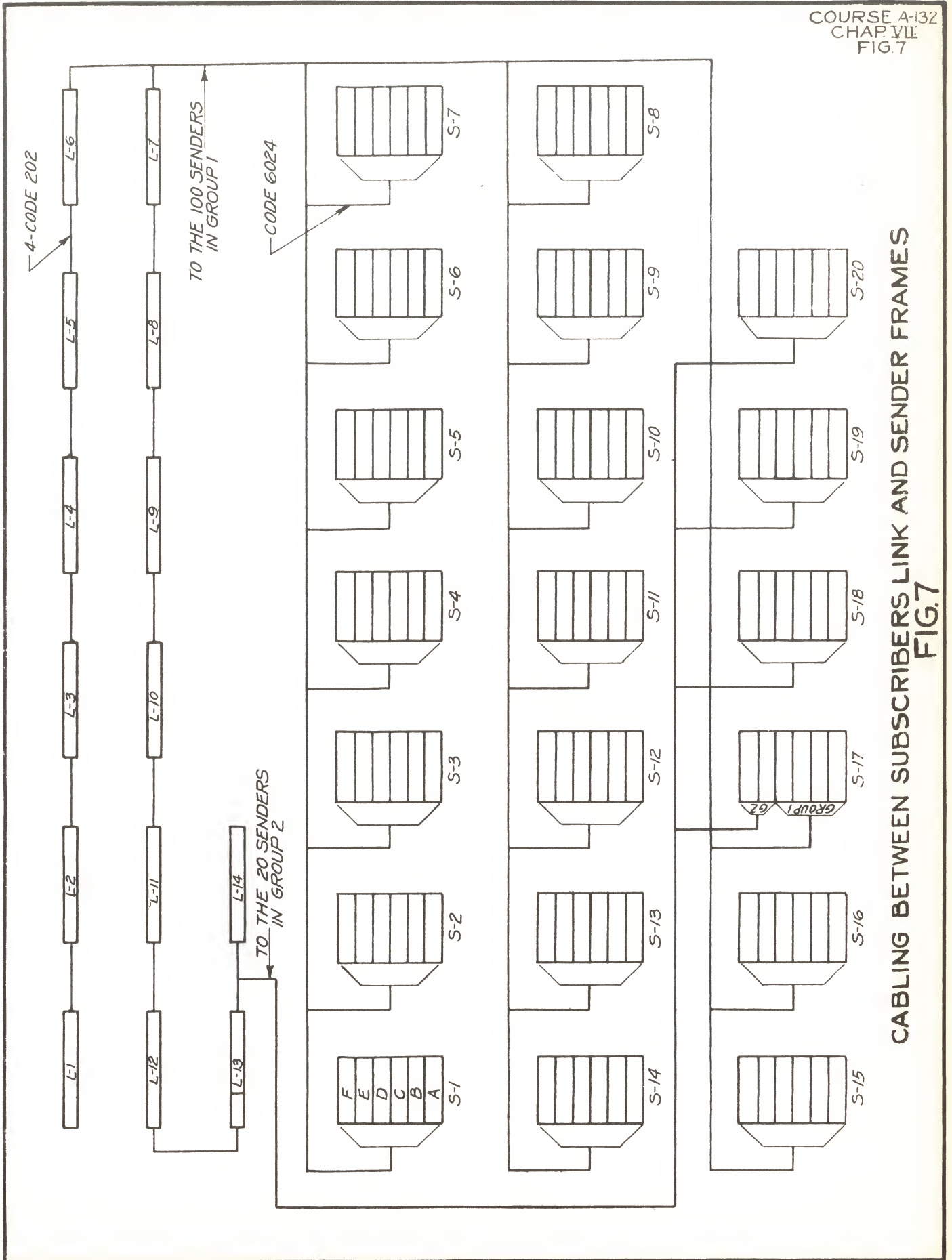

CABLING BETWEEN SUBSCRIBERS LINK AND SENDER FRAMES
FIG. 7

CHAPTER VIII

DIALING AND REGISTRATION

Those parts of the line finder, link and sender circuits which are used in the registration of a dialed number are shown schematically in figure 1. When the link circuit switch enters the "cut through" position, the (L) relay in the sender circuit operates. The operation of the (L) relay causes the operation of the (SR) and (SR1) relays. The (SR1) relay, operated, closes the dial tone circuit whereby dial tone is inductively transmitted to the calling subscriber. Let us assume the subscriber dials Academy 1345. When the dial returns to normal after dialing "A", the line circuit is opened and reclosed twice. The first opening of the line circuit releases the (L) relay, thus operating the (RA), (PH) and (ON) relays and the "A" register stepping magnet. The (RA) relay, operated, operates the register control RC stepping magnet. The (SR) relay is slow in releasing so that it holds over the open periods of the dial pulses. When the line is reclosed by the dial, the (L) relay reoperates, but the (PH) relay holds the circuit, through its own winding and the windings of the (RA) and "A" stepping magnet, closed until the "A" magnet breaks its back contact. The (PH) relay and "A" magnet then release but the (RA) relay is slow to release and holds until all of the pulses for the first digit have been received. The release of the "A" magnet advances the "A" register one step from normal to terminal 1. When the line is opened the second time, the (L) relay again releases, the (RA) relay is held operated and the (PH) relay and "A" magnet reoperate. The (L) relay reoperates at the end of the second open period and the (PH) relay and "A" magnet release as soon as the "A" magnet breaks its back contact. The "A" register is thus advanced another step and its brushes are now making contact with terminal 2. Since the dial has reached normal, the line will not again be opened until the next digit is dialed and during this interval, the (RA) relay, which has been holding during the series of pulses corresponding to the first digit, releases thus causing the release of the "RC" stepping magnet. The "RC" switch is thus advanced one step from normal to terminal 1. The advance of the "RC" switch transfers the pulsing circuit from the "A" register magnet to the "B" register magnet. When the second digit, that is the letter "C" is dialed, the line circuit is again

opened, and reclosed, twice causing the repetition of the series of operations just described except that the "B" stepping magnet, which is operated and released in the pulsing circuit instead of the "A" stepping magnet and the "B" register is advanced from normal to terminal 2. When the second set of pulses has been completed, the (RA) relay and "RC" magnet again release and the "RC" switch is advanced another step so that the pulsing circuit is transferred from the "B" stepping magnet to the "C" magnet. Thus, after each digit, the "RC" switch advances one step so that the pulses corresponding to each digit of the dialed number are registered on a different register. Thus, when ACA 1345 has been dialed, registers A, B, C, have each advanced to the No. 2 set of terminals; the thousands (TH) register has advanced to the No. 1 set of terminals; the hundreds (H) register has advanced to the No. 3 set of terminals; the tens (T) register has advanced to the No. 4 set of terminals; and the units (U) register has advanced to the No. 5 set of terminals. If the call had been to a line in a manual office, a party designation would also have been dialed and the stations (STA) register would have been set in the proper position corresponding thereto. The (ON) and (ON1) relays shown on the circuit are necessary in returning the registers to normal, in some cases, after the sender has completed its operations on a call.

Should one preliminary pulse be transmitted over the dialing circuit before dialing actually begins due to accidental movement of the dial or switch-hook or due to any other temporary open circuits, the "A" register is advanced to terminal 1, closing the circuit in which the (PP) relay operates. The (PP) relay, operated, holds the "RC" stepping magnet circuit closed so that it does not release and transfers the pulsing circuit from the "A" stepping magnet to the 2 ohm winding of the (PP) relay. When the first digit is dialed, the first pulse holds the (PP) relay operated but does not advance the "A" register. The (PP) relay releases after the first pulse, and the second pulse due to the dialing of the first digit advances the "A" register from the No. 1 set of terminals to the No. 2 set of terminals. Should there be but one pulse, a second time, the release of the (RA) relay again reoperates the (PP) relay and prevents the advance of the "RC" switch, and this operation is repeated until more than one pulse is received for the first digit.

To secure the required cycle of operations, the open and closed portions of the dial pulses must be held within certain limits as mentioned previously in Chapter 3 in order that the (L), (RA), and (PH) relays and the register stepping magnets be able to do their work properly. The condensers and resistances connected across the windings of the 200 type selector magnets protect their contacts and the contacts of the (L) and (PH) relays from the energy dissipated each time the circuits are opened.

SUBSCRIBER'S SET

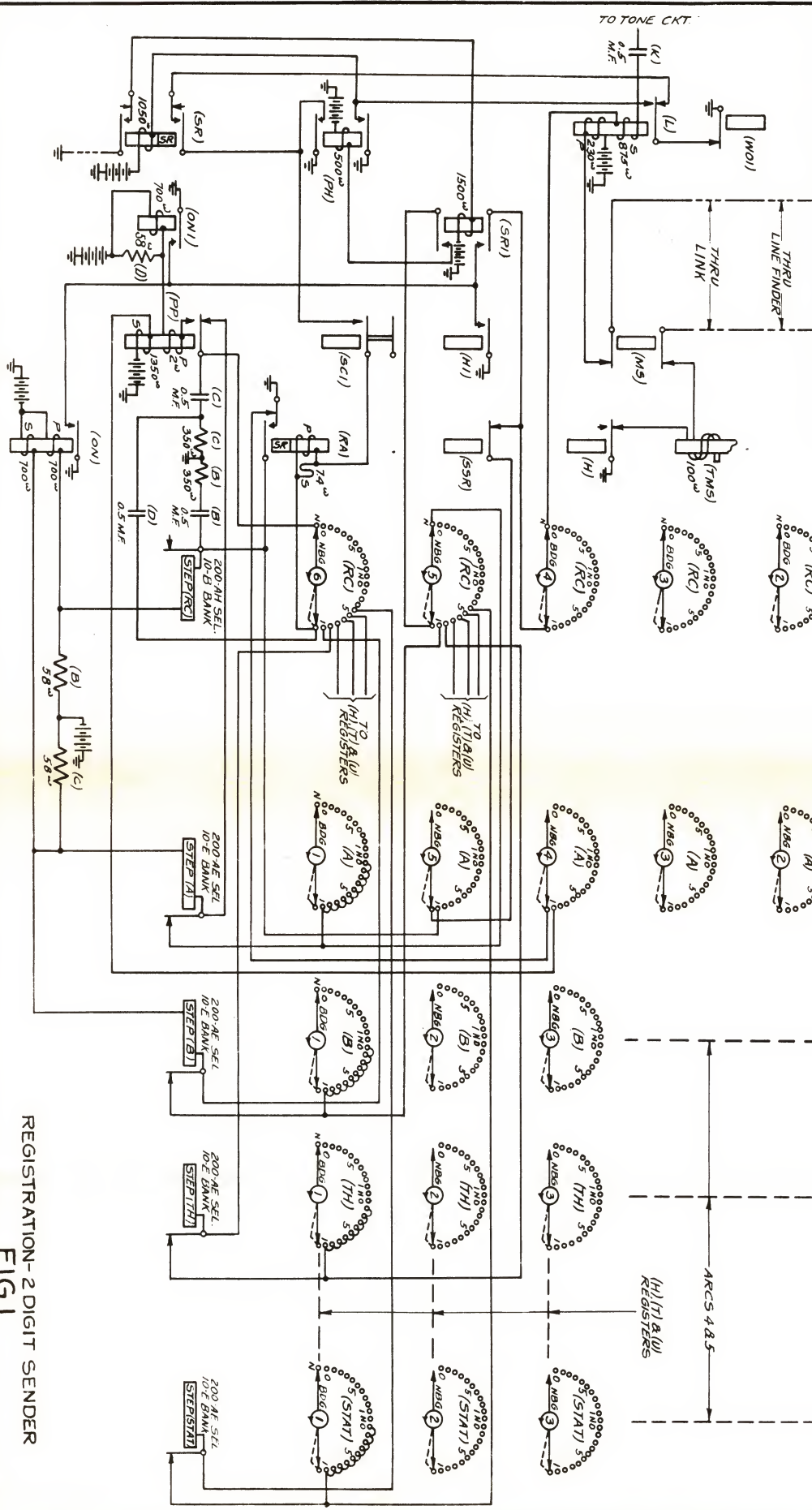
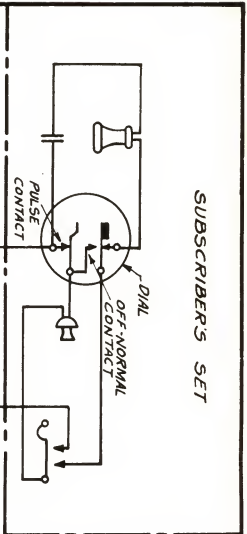

REGISTRATION-2 DIGIT SENDER
FIG. 1

CHAPTER IX

TWO DIGIT TRANSLATION - APPARATUS AND OPERATION

A two digit sender circuit includes either a 44 point or an 88 point translator. The 44 point translator consists of two 1203 type selectors and the 88 point translator consists of four 1203 type selectors. When the 88 point translator is used the first two selectors are sometimes referred to as the first translator and the second two selectors are referred to as the second translator. Each 44 point translator is capable of being set in any one of 44 positions corresponding to 44 different settings of the A and B registers.

The 1203-E selector (which is used in the latest sender circuits), includes two sets of six brushes each, mounted on opposite ends of the same shaft. The brushes are single ended and one set is 180° out of phase with the other set. The brush assembly shaft is supported by bearings in a metal framework on which are also mounted the ROTARY and STOP magnets. The operating circuit for the rotary magnet is under control of a set of normally closed contacts on the stop magnet. Operation of the stop magnet releases the rotary magnet, and also causes a dog to enter between two teeth in the periphery of a wheel, which is mounted on one end of the brush assembly shaft, so as to center and hold the brushes in this position. For each set of brushes there is a multiple bank similar to that used with the 200 type selector. The brush and magnet unit is attached to the multiple bank framework by machine screws, thus permitting its removal without disturbing the multiple bank wiring. Since the brushes of only one of the brush assemblies are in contact with multiple terminals at one time, the selector as a whole lends itself to the selection of any terminal in either one of the two banks, that is, any one of 44 sets of terminals. Each selector of this type can therefore control the same number of circuits as the 200 type selector but has a choice of double the number of terminals.

Two selectors are required for each 44 point translator since there are more than 6 circuits which are controlled by its setting. Two brushes are used for hunting the proper position in which it should be set and the remaining 10 brushes govern the further operation of the sender. The two banks associated with one of the selectors in the first translator are designated T1-A and T1-B and the two banks associated with the other selector in the first translator are

designated T1-C and T1-D. Similarly the four banks associated with the two selectors in the second translator are designated T2-A, T2-B, T2-C and T2-D. Each one of the six arcs in a bank is distinguished from the other arcs in the same bank by adding to the bank designation the arc numbers 1, 2, 3, 4, 5 or 6. To illustrate, the arcs in the first bank of the first translator are designated T1-A1, T1-A2, T1-A3, T1-A4, T1-A5 and T1-A6 respectively. The terminals in the "A" and "C" banks combined respectively with the terminals in the "B" and "D" banks form two sets of 44 terminals each, those in the "A" and "C" banks being numbered from 1 to 22 inclusive and those in the "B" and "D" banks being numbered from 23 to 44 inclusive.

After the "A" and "B" registers are set a translator hunting circuit is used to set the translator in a position which corresponds to the setting of the "A" and "B" registers. The #1 arcs in each of the banks of a translator are used for the hunting circuit and are called "hunting arcs". Four of the "B" register arcs are used with two of the "A" register arcs to control and secure the proper translator setting on each particular call. The eight terminals on the A3 arc (with one of which the A3 brush is making contact after dialing the first number of the two digit code) are connected in pairs to the B2, B3, B4 and B5 brushes of the B register, respectively; that is, terminals 2 and 3 of the A3 arc are connected to brush B2, terminals 4 and 5 to brush B3, etc. The terminals on the four arcs of the "B" register are then cross-connected to the terminals on the translator hunting arcs. With the "B" register set in any one of eight positions (exclusive of 0 and 1) each terminal on the four arcs of the "B" register represents either one of two settings on the "A" register, and each one of the 32 "B" arc terminals are connected to two translator points, one in the first half of one translator and the other in the last half of the same translator. The 44 terminals on the hunting arcs of one selector are multiplied to the corresponding terminals of the second selector in each 44 point translator; that is, the 44 terminals in arcs T1-A1 and T1-B1 are multiplied to the terminals in arcs T1-C1 and T1-D1 and the 44 terminals in arcs T2-A1 and T2-B1 are multiplied to the terminals in arcs T2-C1 and T2-D1. It is necessary to distinguish between the two translators (when two 44 point translators are used)

and between the two halves of each translator. To this end the terminals on arc A2 are connected to transfer relays which control the translator hunting circuit in such a way as to hunt in that one of the translator arcs in which the terminal corresponding to the setting of the "A" and "B" registers is located. One translator relay is sufficient to secure this distinction when the 44 point translator is used but six relays are required when the 88 point translator is used. When the setting of the "A" and "B" registers is such that the corresponding point on the translator hunting arc is in the T1-A and T1-C arcs (terminals 1 to 22 inclusive) none of the transfer relays operate and the hunting circuit is closed through brushes T1-A1 and T1-C1; when the setting of the registers is such that the corresponding point on the translator hunting arcs is in the T1-B1 and T1-D1 arcs (terminals 23 to 44 inclusive) the hunting circuit is transferred by the operation of the proper transfer relays (as controlled by the position of the A2 brush) to the T1-B1 and T1-D1 translator brushes; when the setting of the registers is such that the corresponding point on the translator is in arcs T2-A1 and T2-C1 the hunting circuit is closed by the transfer relays through the T2-A1 and T2-C1 brushes; and, when the setting of the registers is such that the corresponding point on the translator is in arcs T2-B1 and T2-D1 the hunting circuit is closed by the transfer relays through the T2-B1 and T2-D1 brushes. Careful study of the attached sketch should be made to obtain a clear idea of how each one of the translator brush positions represents and corresponds to a particular code or setting of the "A" and "B" registers.

As soon as the subscriber in a two digit office has completed dialing and the office code and the "A" and "B" registers have been set, the sender knows to what office the call must be routed; and to that end the first step is to translate the code which has been registered. This consists of establishing circuit control conditions, which will cause the selector mechanisms (the district and office selectors) to select an idle trunk to the office whose code has been registered. When the "RC" switch is advanced to position 2 after the setting of the "B" register, a circuit is closed which operates the (ST) relay. We will assume that the sender under consideration has a 44 point translator.

The (ST) relay locks and connects ground through the A3 register brush and through either the B2, B3, B4 or B5 brushes to a terminal on each of the T1-A1 and T1-B1 or T1-C1 and T1-D1 translator arcs. The operation of the (ST) relay also closes circuits in which the rotary magnets ROT. T1-A and ROT. T1-B operate causing the brush assemblies on these two 1203 type selectors to be advanced. When the translator hunting arc brushes make contact with the terminals to which the ground from the make contacts of the (ST) relay is connected, the stop magnets STOP T1-A and STOP T1-B operate. Operation of the STOP magnets opens the rotary magnet circuits and stops the two brush assemblies on that set of terminals which corresponds to the setting of the A and B registers. The operation of the STOP magnets also closes the circuits in which the (TS1) and (TS2) relays operate. The (TS1) and (TS2) relays, operated, close circuits for holding the STOP magnets operated and for holding their own windings energized.

We now have the translator set in a position which corresponds to the setting of the "A" and "B" registers and in this position the ten translator brushes other than the hunting brushes are in a position to cause the sender to control the selector mechanisms so as to establish the desired connection. The translator A2 and B2 arcs (designated (BO), Beyond Office) control the compensating resistance which is inserted in the "fundamental circuit" for incoming and final selections; the A3 and B3 arcs (designated (OS), Office Selections) control the compensating resistance which is inserted in the "fundamental circuit" for office selections; the A4 and B4 arcs (designated (TS), Talking Selection) control "talking selection"; the A5 and B5 arcs (designated (SD), Stations Delay) control the time allowed for dialing a party designation on a call to a manual office; the A6 and B6 arcs (designated (SO), Skip Office) are used to tell the sender when office selections are required and when they are to be skipped (that is, when no office selector is used); the C2 and D2 arcs (designated (OG), Office Group) control office group selectors and the C3 and D3 arcs (designated (OB), Office Brush) control office brush selection, when an office selector is used in completing the call; the C4 and D4 arcs (designated (DG), District Group) control district group selection; the C5 and D5 arcs (designated (DB), District Brush) control district brush selection; and the C6

and D6 arcs (designated (CL), Class) are used to set the class switch in a position which corresponds to the class of call being made.

We will consider but one of these control circuits at this time, that being the one which causes the sender to set up the conditions necessary for completing different classes of calls. In one of the sketches associated with this chapter is shown the class switch and class set circuit.

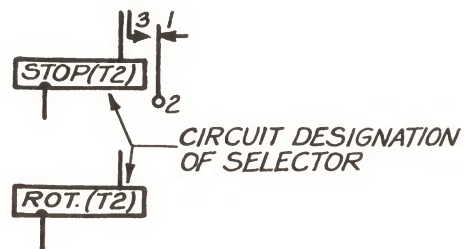
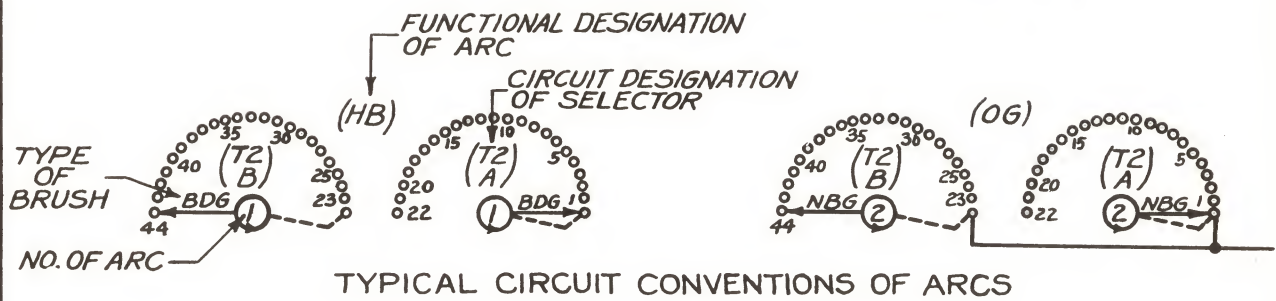
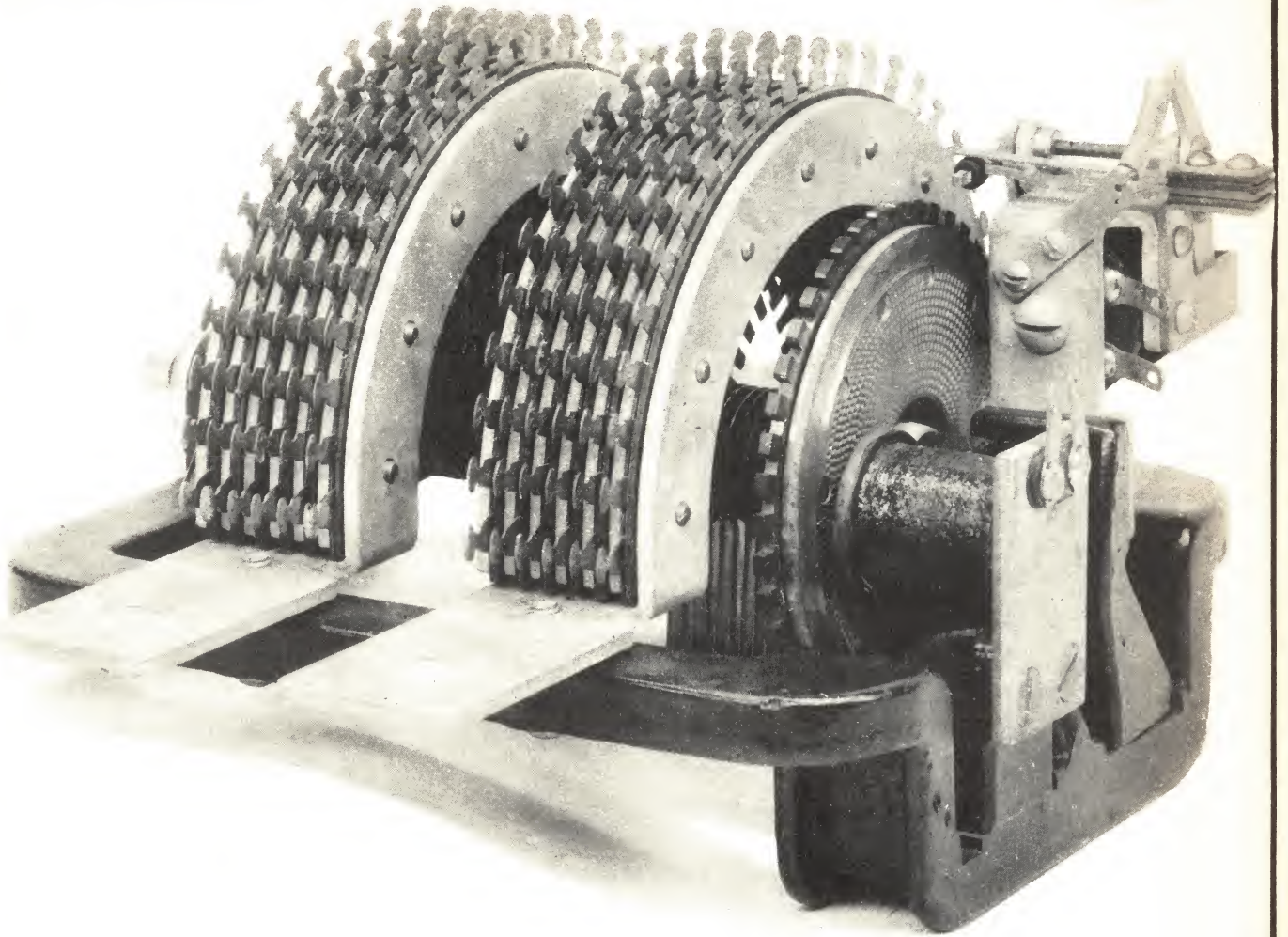

POWER DRIVEN SELECTOR-1203 TYPE
 FIG. 1

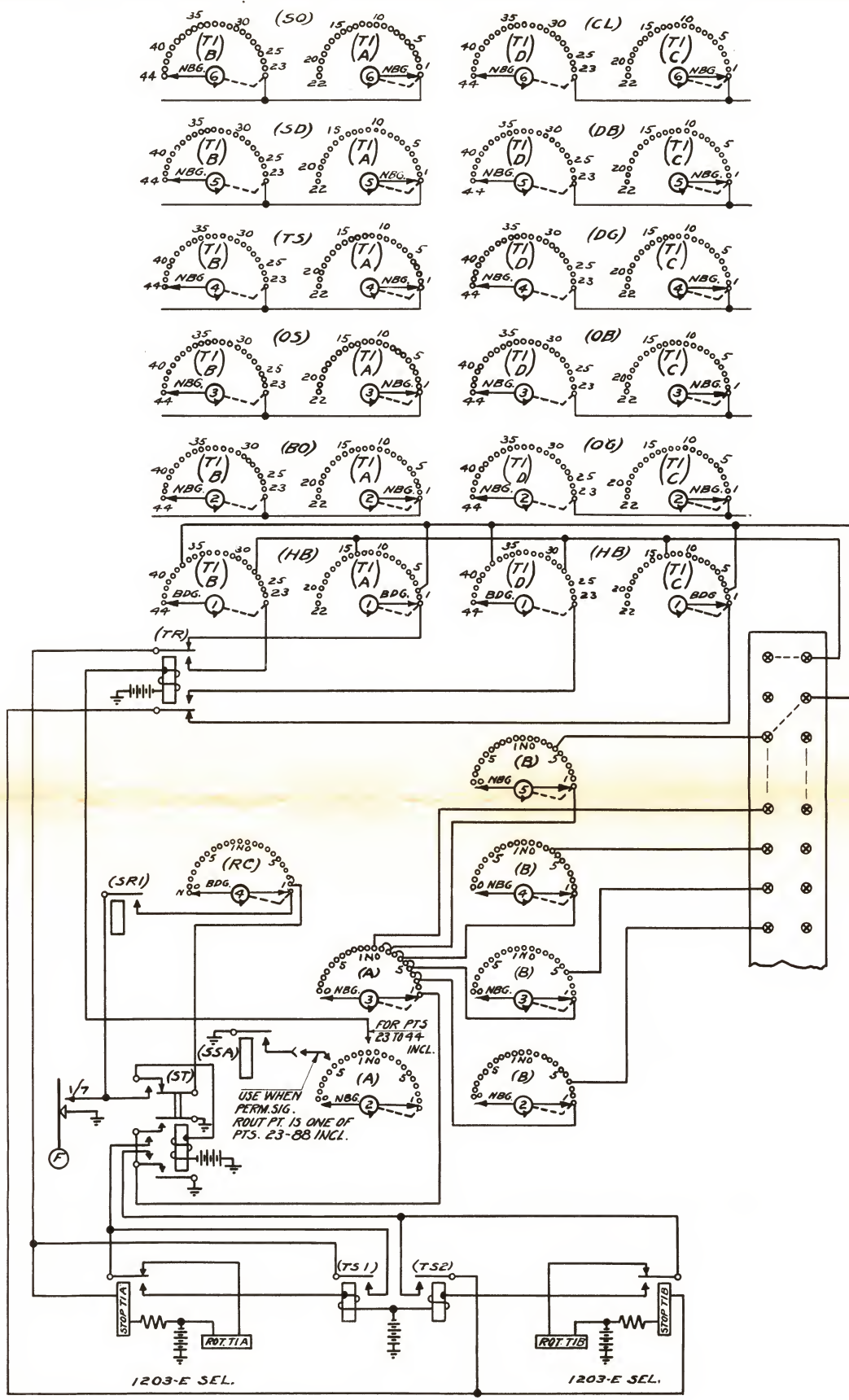

TRANSLATION - 2 DIGIT SENDER
FIG. 2

CLASS
 SEQ. SW. (R3)

- 1-7-13 MECH. S.H.
- 2-8-14 R.C.I. TANDEM
- 3-9-15 R.C.I. DIRECT
- 4-10-16 MECH. L.H.
- 5-11-17 RESTRICTED ZONE
- 6-12-18 OPERATOR

CROSS CONNECT TO LEADS
 ON CLASS SWITCH AS REQ'D.

(CL)

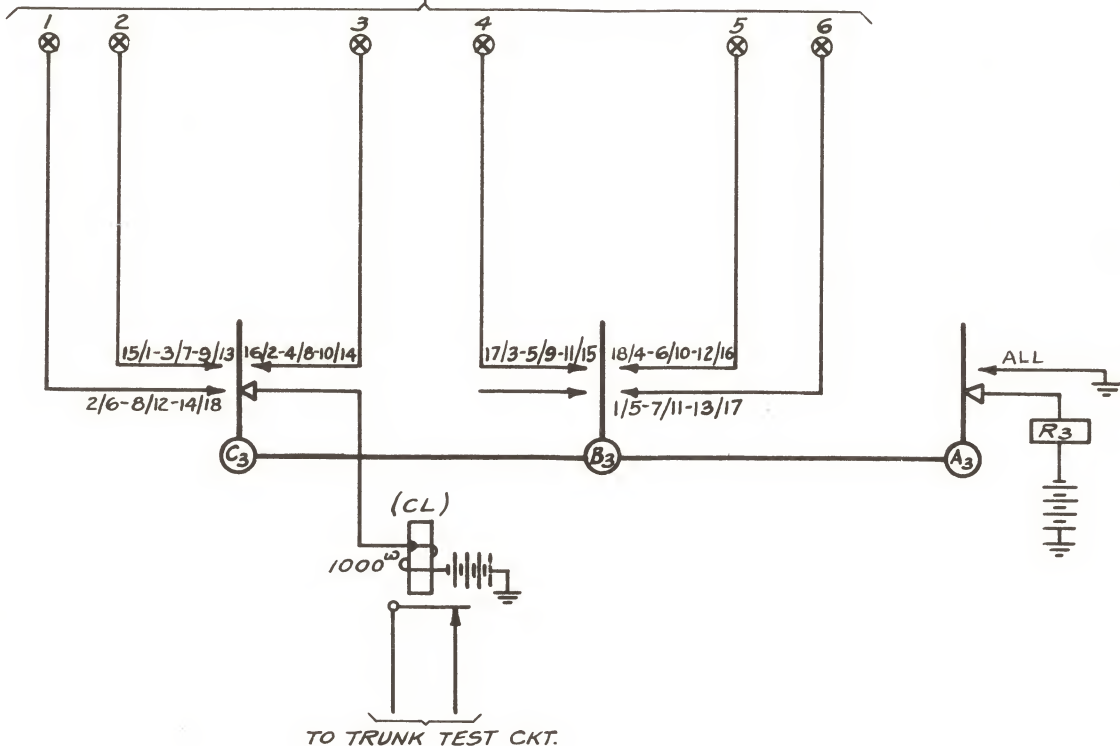
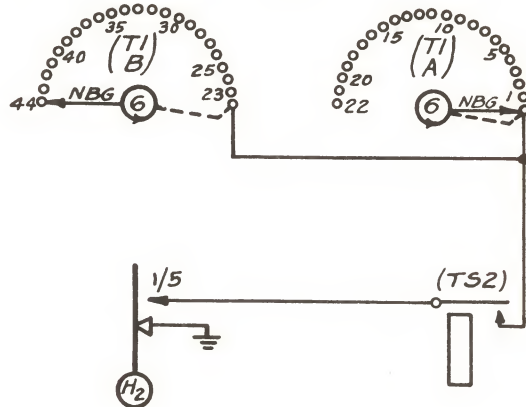

SETTING CLASS SWITCH
 FIG. 3

CHAPTER X

DISTRICT AND OFFICE SELECTOR FRAMES

The panel type selectors which are used to select an idle trunk to the office in which the called line terminates are called "District" and "Office Selectors". In some cases the number of destinations and the number of trunks required to each destination make it necessary to use both district and office selectors, and in other cases enough groups of proper size can be obtained by the use of only district frames and the office frames are omitted. The first selector whose operation is controlled by the sender after translation is completed is the district selector. This selector is a part of the "line finder-district" circuit and is mounted on a frame called a district frame. The cabling which connects the district multiple on the link frame, the line finder on the line finder frame, and the district selectors on the district frame was shown in sketches associated with Chapters IV and V. There are 6 leads between each frame and the leads for 5 circuits are carried in each cable, terminating on a terminal strip mounted on the end of the selector frame.

The district selector frame is a double-sided frame consisting of five bays. On the central bay are mounted the five multiple banks, the friction roll drive, clutches, brush rods and commutators. The sequence switches associated with the selectors on the front of the frame are mounted in the next bay to the right of the multiple banks when facing the front of the frame; and the sequence switches associated with the selectors on the rear of the frame are mounted in the next bay to the right of the multiple banks when facing the rear of the frames. On the two end bays are mounted the relays, repeating coils, resistances and condensers adjacent to the sequence switches with which they are associated. At the bottom of the end bays are mounted the fuse panel and the jack panel. On the earlier district frames the repeating coils and condensers used in the talking circuit were located on coil racks, as in manual offices and in that case the relays for each circuit were on a mounting plate opposite the sequence switch with which they were associated. To permit mounting the repeating coils on the district frame the relays, coils and condensers of five circuits are located opposite five sequence switches.

The relays and resistances are mounted on 2" mounting plates and the repeating coils on 4" plates. In order to provide space at the bottom of the relay bay for the horizontally mounted jack and fuse panels the relays of five circuits are located at the top of the space occupied by their associated sequence switches and the repeating coils and condensers of the same five circuits are mounted at the bottom of the space occupied by the group of five sequence switches immediately above. For example, the relays of the first five circuits are placed opposite sequence switches Nos. 5, 7 and 9 and the associated coils and condensers opposite sequence switches Nos. 11 and 13. The six terminal strips on which the cables from the line finder and link frames terminates are mounted at the end of the relay bays.

Each multiple bank consists of 100 sets of three terminal strips each. Each strip is punched so as to have 30 terminals projecting from each edge to which the multiple brushes of the 30 selectors on each side of the frame have access. The brush rods are similar to the line finder brush rods being hollow metal tubes with a rack attached to the lower end and a commutator brush attached to the upper end. The brush rods are equipped with five brushes similar to those used on the line finder frames and their springs do not make contact with the banks terminals until the brush has been tripped in order that only one brush on the rod be in use at one time. The first five slots in the rack are used for holding the brush rod in one of five positions to which it is elevated in the selection of the brush which is to be tripped on any particular call. When elevated to a position in which the pawl has engaged with the first slot the selector is in position for having the first multiple brush tripped when the rod is again moved upward, providing the trip magnet is energized. Likewise, when the rod has been elevated to a position in which the pawl has entered the second slot in the rack it is in position for having the second brush tripped, etc. The trip mechanism differs from that used on the line finder frame in that each brush rod, or selector, has an individual trip magnet which is part of the clutch. Operation of this trip magnet forces its armature against a lever which is attached to the lower end of a long vertical rod known as a trip rod, causing the rod to rotate on its vertical axis thru

an angle of about 30°. It is located between the brush rod and the multiple banks and extends from the top of the clutch magnet through the brush rod bearing plate to the top of the fifth bank. A retractile spring holds the rod in its normal position when the trip magnet is not energized. Five trip fingers are attached to the trip rod, one for each multiple brush. When the brush rod is in one of the five brush selection positions, and the trip magnet is energized, the trip finger corresponding to this position engages with the trip lever on the brush to be tripped and subsequent upward motion of the brush rod causes the trip lever on this brush to be tripped. In the tripped position the brush springs make contact with the terminals on the multiple bank to which they have access. To illustrate, assume that the brush rod has been driven upward to a position in which the pawl has entered the third slot in the rack, and that the trip magnet is energized. Under these conditions the third trip finger on the trip rod has engaged with the trip lever on the third or #2 brush. The first and second trip fingers on the trip rod passed below the trip lever on the first and second, (#0 and #1) brushes and the fourth and fifth trip fingers passed above the fourth and fifth, (#3 and #4) brushes on the brush rod. When the selector again moves upward the third or #2 brush is tripped. Except for the addition of a trip magnet the clutch is otherwise similar to the clutch used on the line finder frame. The commutator and commutator brushes are modified as required for use in the district selector circuit and are shown on a sketch associated with this chapter.

To the 100 sets of multiple strips in each bank are connected groups of local or interoffice trunks. The spacing of the B and Z segments on the district commutator divides these terminals, from a circuit operation viewpoint, into 8 groups of 11 terminals each and 2 groups of 6 terminals each. The Z commutator segments are associated with the top set of terminals in each group; these terminals are not connected to a trunk but are used as "overflow" terminals. The bank itself is not physically divided into groups but the "overflow" terminals indicate the upper limit of each trunk group in the bank. When more than 10 trunks are required to any destination two or more adjacent groups of terminals in the same bank are combined and the "overflow" terminals

of all the combined groups except the top group are arranged to test the same as busy trunks. The district selector will thus hunt over the trunks in the combined group in the same manner as though they were one large group. The district multiple can therefore be arranged in any desired combination from 40 groups of 10 active trunks each and 10 groups of 5 trunks each to 5 groups of 90 trunks each. The selection of the group which contains the trunks which go to the required destination on any particular call is called "Group Selection". When the brush rod has travelled upward so that the brush springs of the tripped multiple brush are in contact with the first trunk in the proper group, the UP magnet is deenergized and the pawl engages with the slot in the rack which corresponds to this first set of terminals. Since all of the trunks in this group go the same destination any one of them can be used to complete the call and the selector circuit selects an idle trunk out of this group. Operation of the district selector during Brush and Group Selections and during Trunk Hunting are described in the next chapter.

The 3-wire office selector frame is similar to the district selector frame. It has a regular 60 selector capacity double-sided central bay, containing banks, drives, clutches, brush rods and commutators, and on bays at each end are mounted the sequence switches and associated relays. The three wire office selector circuit has but one relay which is mounted on a vertical mounting plate located at the end of the sequence switch bay. The relays for five circuits are mounted on one plate. The banks, drive mechanism, brush rods, commutators and trip mechanism are identical with those used on the district frame.

160-TYPE INT

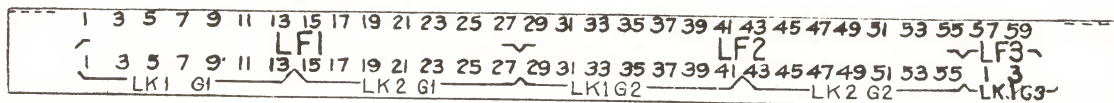
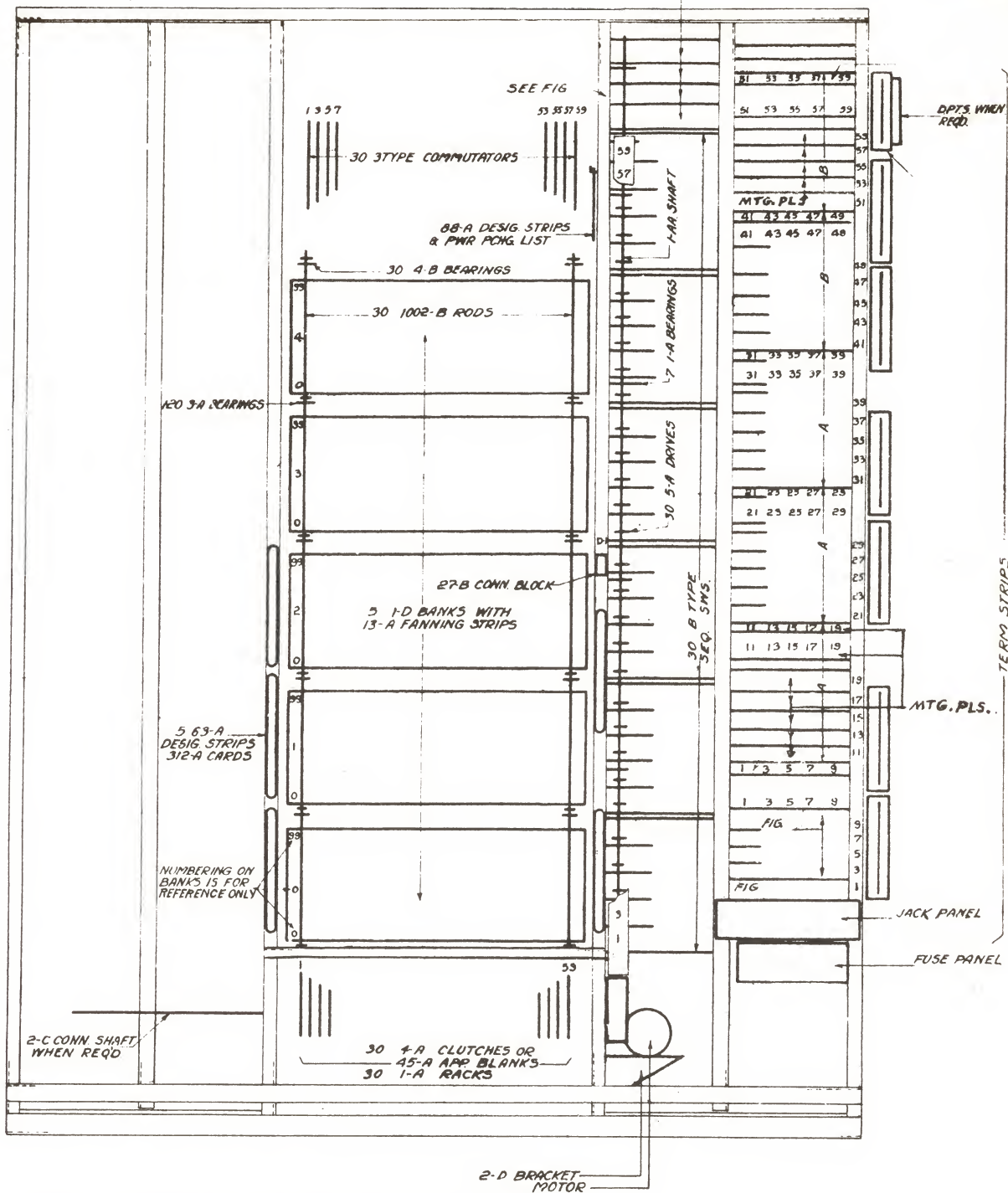

NUMBERING ON FRONT CLUTCH GUARD RAIL

FIG. 1

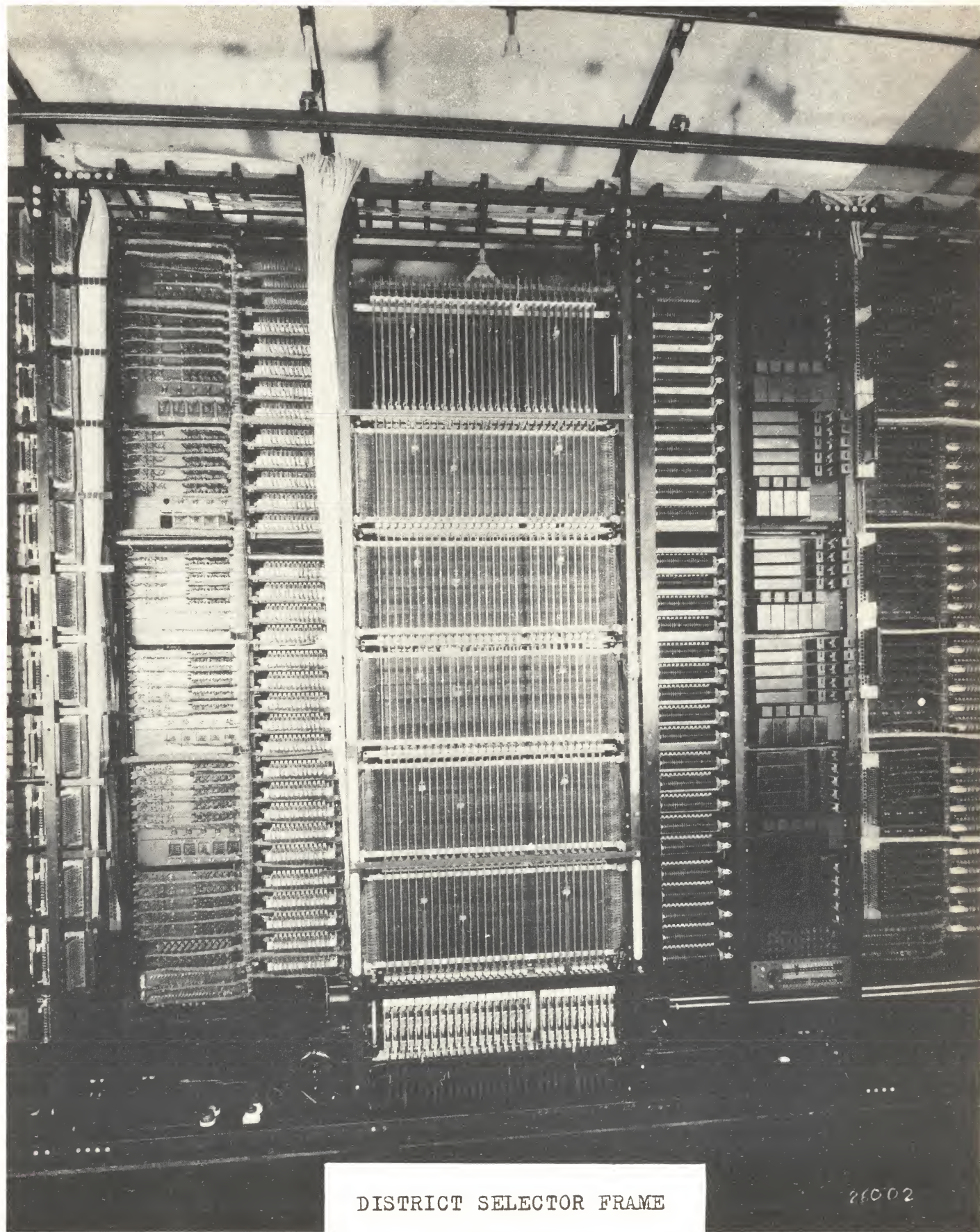

DISTRICT SELECTOR FRAME

26002

FIG. 2

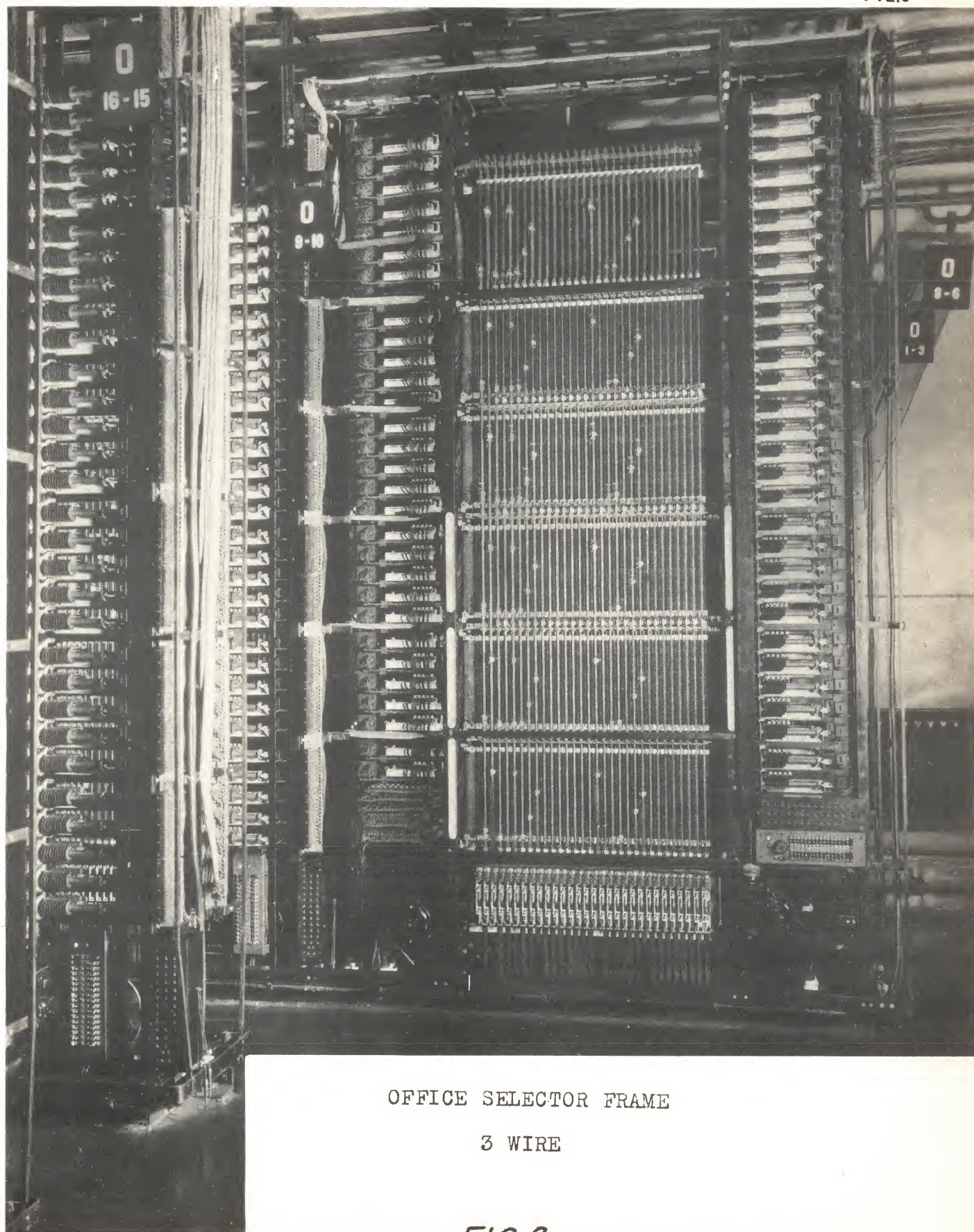

OFFICE SELECTOR FRAME

3 WIRE

FIG. 3

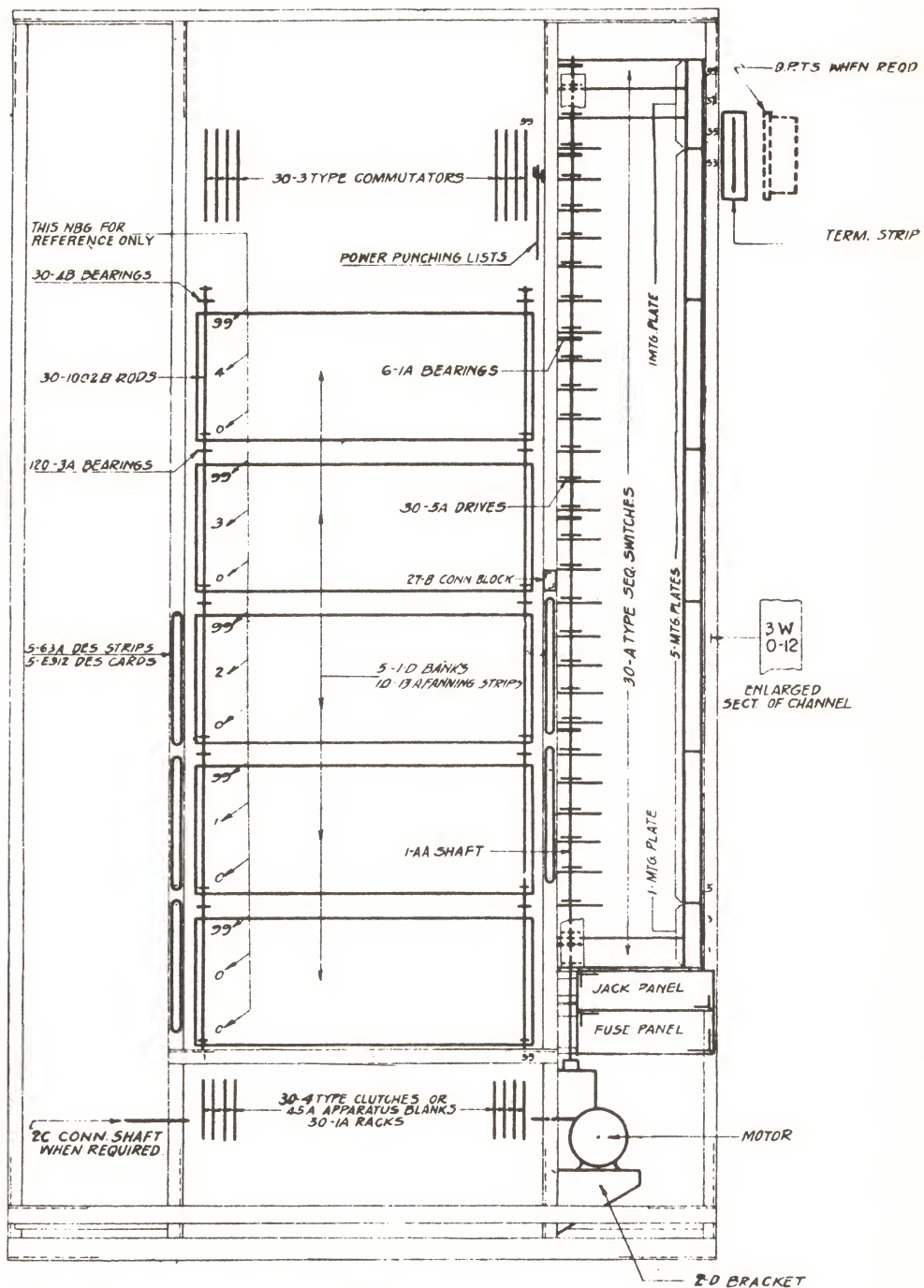

FRONT
 EQUIPMENT ON REAR SAME AS ABOVE
 EXCEPT NUMBERING TO BE 2, 4, 6 TO 60

OFFICE SELECTOR FRAME
 3 WIRE
 FIG. 4

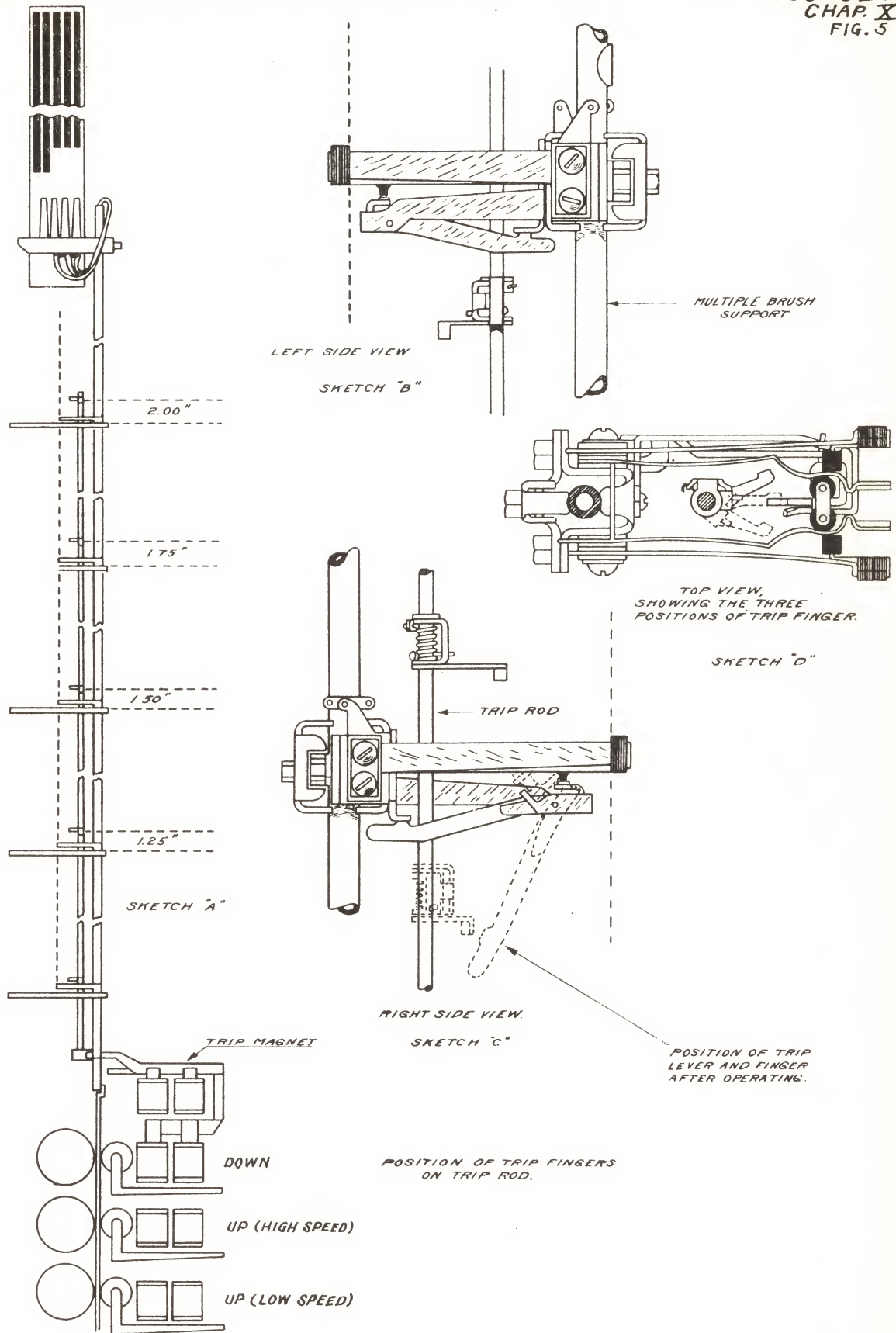

TRIPPING MECHANISM
FIG. 5

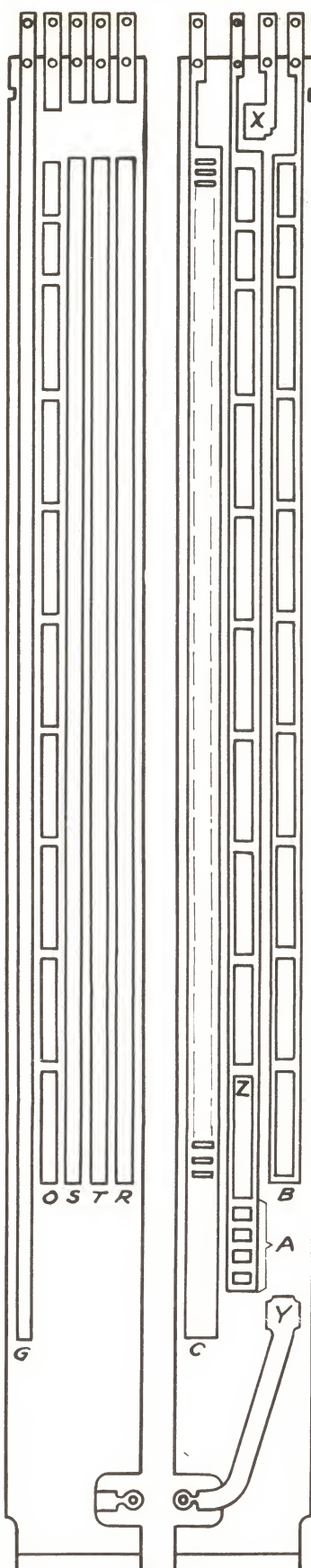

3-D
DISTRICT AND OFFICE COMMUTATOR
FIG. 6

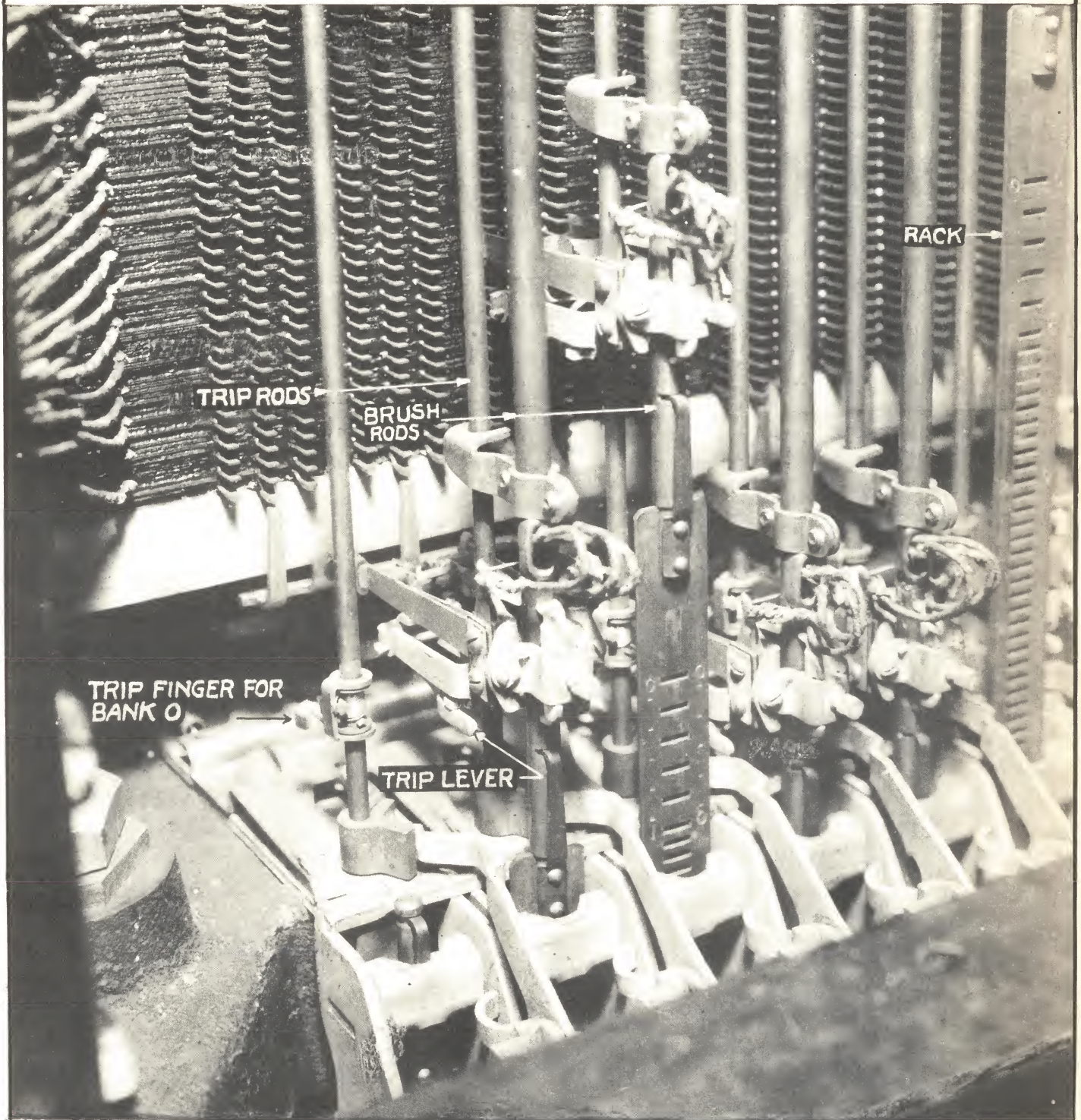

PANEL SELECTOR BRUSH AND TRIP RODS
FIG. 7

CHAPTER XI

DISTRICT AND OFFICE SELECTIONS AND TRUNK HUNTING

Before considering the out trunking arrangement the operation of the district and office selectors during brush and group selections (as controlled by a two digit sender circuit) and also the operation of these selectors during trunk hunting will be explained. Assuming that translation has been completed the sender is ready to control district selections. Figure 1 associated with this Chapter shows schematically those parts of the sender and selector circuits which are necessary to this explanation. On this and on following schematics the complete wiring to the counting relays is omitted and the counting relay windings are shown connected to circles within each of which is shown the number of the pair of counting relays to which it is connected. The other points in the circuit to be connected to these leads are designated in a similar manner, or the wiring required is specified by a bracket and note such as "Connect the points on the DB translator arc to counting relays 0 to 4 as required". The circuit which controls selections is called the "Fundamental Circuit" and is essential to the operation of a panel system. The operation of the (TS-1) and (TS-2) relays advances the R1 switch to position 2 and closes the fundamental circuit for district brush selection. This circuit is traced from battery through one winding of the district (L) relay over the "FT" lead through the link circuit through the back contact of the (BO) relay, windings of the sender "Stepping" (STP) and "overflow" (OFL) relays, and through a 1000 ohm resistance to ground. The (L) and (STP) relays operate but the (OFL) relay does not operate since it is a polarized relay and the current is not in the operating direction at this time. The 1000 ohm resistance is included in this circuit so as to hold the current below a value which will prevent the fast release of the (STP) relay. The (L) relay, operated, closes a holding circuit for its own winding in positions 3/6 and advances the district switch to position 4, in which position the UP magnet is energized and the selector is driven upward. The operation of the (STP) relay in the sender closes a circuit for operating that one of the counting relays whose winding is cross-connected to the terminal on the DB translator arc with which the DB brush is making contact. Let us further assume that it is the (2) counting relay which is thus operated. The operation of the (2) counting relay connects ground to the inner end of the

(2') counting relay but as long as the (STP) relay holds in the fundamental circuit the (2') relay cannot operate since ground is connected to both ends of its winding. As the district selector moves upward the (A) commutator brush makes contact with the first metal segment of the (A) commutator, connecting ground thereto. In so doing the (STP) relay is short-circuited but the district (L) relay is held operated. The release of the (STP) relay opens the short circuit around the winding of and operates the (2') counting relay. The (2) and (2') counting relays are thus locked in position 1 of the R2 switch. When the district selector has travelled upward far enough so that the (A) brush breaks contact with the first metal segment and again rests on insulation the short circuit around the (STP) relay is removed and the (STP) relay reoperates in series with the district (L) relay. The operation of the (2') counting relay and the reoperation of the (STP) relay closes the circuit from ground through the make contact of the (STP) relay through the DB translator arc so as to operate the (1) counting relay. The (1) counting relay operated connects ground to the inner end of the (1') counting relay but the (1') relay cannot operate until the release of the (STP) relay removes the short circuiting ground from its outer end. This occurs when the district selector has travelled upward so that the (A) commutator brush makes contact with and connects ground to the second metal segment of the (A) commutator. The (L) relay is held and the (STP) relay is short-circuited by this ground. The (STP) relay releases causing operation of the (1') counting relay and this pair of counting relays is locked in position 1. With the (L) relay held operated the UP magnet remains energized and when the (A) commutator brush breaks contact with the second metal segment the (STP) relay reoperates and closes a circuit through the DB translator arc so as to operate the (0) counting relay. The operation of the (0) counting relay connects ground to the inner end of the (B0) and (F0) relay windings. When the (STP) relay is again released due to being short-circuited by the (A) commutator brush making contact with the third (A) commutator segment, the (B0) and (F0) relays operate and lock in position 1/1 1/4. The operation of the (B0) relay opens the fundamental circuit and releases the district (L) relay. The release of the (L) relay opens the UP magnet circuit and the selector drops back against the pawl which has entered the third slot in the rack. The

release of the (L) relay also advances the district switch to position 5 in which position the TRIP magnet is operated, rotating the trip rod so that the third trip finger engages with the trip lever on the third or #2 brush. The operation of the (FO) relay in the sender circuit advances the R2 switch to position 3. The counting relays which were operated release when the switch advances, but the (O), (BO) and (FO) relays hold until it has advanced far enough to insure that the fundamental circuit cannot again be closed until the switch enters position 3 for district group selection.

With the selector switch in position 4 and the district switch in position 5 the fundamental circuit is again closed operating the district (L) and sender (STP) relay. The (L) relay, operated, advances the district switch to position 6 in which position the (L) relay holds and the district UP magnet is energized, as the brush rod moves upward the #2 brush is tripped. The operation of the (STP) relay closes a circuit through the DG translator arc to that counting relay which is cross-connected to the terminal with which the DG brush is making contact. The B commutator brush alternately short-circuits and removes the short circuit from the sender (STP) relay in the fundamental circuit as did the A commutator brush during brush selection. Each operation and release of the sender (STP) relay causes the operation and locking of one pair of counting relays. These metal segments on the B commutator are spaced so as to short circuit the stepping relay when the tripped multiple brush reaches the first set of terminals in a group. When sufficient B commutator closures have been made to satisfy the sender the operation of the (BO) and (FO) relays opens the fundamental circuit and advances the R2 switch to position 4. With the R2 switch in position 4 the R1 switch is advanced to position 3, in which position a circuit is closed for OFFICE TEST as shown in Figure 3. The opening of the fundamental circuit releases the district (L) relay thus releasing the UP magnet and stopping the selector in such a position that the tripped multiple brush makes contact with the first trunk in the selected group. Release of the district (L) relay also advances the district switch to position 7.

The sender has now caused the district selector to select a group of trunks in one of the 5 banks on the frame in accordance with the setting of the (A) and (B) registers as indicated by the setting of the translator. The

district selector is ready to select an idle trunk out of this group. Figure 2 shows schematically those parts of a panel type selector circuit which are used during trunk hunting. The (L) relay reoperates in position 7/7 1/4 in local circuit advancing the switch to position 8. When the switch advances beyond position 7 1/4 the operating circuit through the S winding of the (L) relay is opened but a circuit is closed through its P winding to the sleeve terminal of the set with which the tripped brush springs are in contact. If this first trunk is idle the (L) relay releases since there is no ground on the sleeve terminal to hold it operated. In this case when the switch enters position 8 the UP magnet is not energized and the selector is not again moved upward. If the sleeve terminal of the first trunk is grounded indicating that the trunk is in use, the (L) relay holds through its P winding to this ground and when the switch enters position 8 the UP magnet circuit is closed and the brush rod is driven upward. The S winding of the (L) relay is connected to the C commutator and the C commutator brush is strapped to the G commutator brush. The inner pair of brush springs on the multiple brush of a trunk hunting panel selector makes contact with opposite sides of the sleeve terminals. The center of the spring which makes contact with the left side of the sleeve terminals is a little below the center of the spring which makes contact with the right side of the sleeve terminals. Thus one of the sleeve brush springs do not break contact with a sleeve terminal until after the other sleeve brush spring makes contact with the next sleeve terminal in the bank. A multiple brush with its inner pair of springs staggered in this manner is called a bridging brush. The (L) relay is thus held through its P winding to ground on the sleeve terminals of busy trunks, and the elevator is driven upward until the sleeve brush spring makes contact with a sleeve terminal which is not grounded. The circuit through the P winding is thus opened but the S winding circuit holds the (L) relay operated through the C commutator brush and segment until the brush rod has travelled high enough to insure centering the brush springs on the terminals of the idle trunk, when the UP magnet releases. The selector rod is carried a little beyond this set of terminals so that the pawl engages with the proper slot in the rack, and the rod then drops down against the pawl. Ground is fed to the G commutator through the make contact of the (L) relay during trunk hunting so that in case of an

overthrow of the selector, after the (L) relay releases, the (L) relay will not reoperate to ground through the next C commutator segment and thus cause the selector to over-step. The release of the (L) relay as soon as the idle trunk has been selected connects ground to the sleeve terminal of this trunk so that it will test busy to any other selector which may be hunting or which may later hunt for an idle trunk in this same group. The release of the (L) relay advances the district switch to position 9.

If all of the trunks in the group are busy when the selector is trunk hunting the brush rod is driven to the top set of terminals in the group. This set of terminals is known as the "overflow" terminals. Ground is never connected by the selector circuit to the sleeve terminal of this set in order that no selector will continue hunting in the next group of trunks in an attempt to find an idle set of terminals. The release of the (L) relay stops the selector on the "overflow" terminals, and an "all paths busy tone" is transmitted to the calling subscriber as will be further explained later in these notes.

The district (L) relay reoperates in local circuit thru the make contact of the district (SC) relay advancing the district switch to a position designated "selection beyond", in which position the district connects the T and R terminals of the selected trunk to the "FT" and "FR" leads from the sender circuit. When the T and R terminals of the selected trunk are connected to the "T" and "R" leads of an office selector, a circuit is closed for "office test". See Figure 3. Before proceeding with office selections the sender makes a test to see if the trunk to the office selector is closed and to see if the selector is in its normal position. This circuit is traced from battery thru the P winding of the office (L) relay, over the "T" lead to the district circuit, over the "FT" lead to the link circuit, over the "FT" lead to the sender circuit, thru a 14,500 ohm resistance, winding of the Trunk Guard (TG) relay, winding of the (OFL) relay, thru the (OS) translator brush and arc, compensating resistance, over the "FR" lead to the link circuit, over the "FR" lead to the district circuit, over the "R" lead to the office circuit to ground thru a 1000 ohm resistance. The office (L) relay does not operate but the sender (TG) relay operates causing operation of the (TG1) relay. The (TG1) relay closes the R1 magnet circuit advancing the R1 switch to position 4.

Office selections are controlled by the sender and completed by the office selector in the same manner as that in which district selections were completed with the following exceptions: (1) The fundamental circuit is a 2 wire circuit similar to the office test circuit except that the (STP) relay is included instead of the (TG) relay and 14,500 ohm resistance. Compensating resistance is inserted in this circuit by the translator in such an amount as is required to hold the current in the fundamental circuit below a value which will prevent the fast release of the stepping relay during selections. (2) The counting relays which are operated during office brush and office group selections are under control of the setting of the OB and OG translator brushes instead of being under control of the setting of the DB and DG translator brushes. (3) The R1 switch is advanced from position 4 to position 6 when office brush selection is completed, and is advanced to position 7 when office group selection is completed. When the R1 switch enters position 7 the R2 switch is advanced to position 5 for "Trunk Test". The office selector selects an idle trunk in the selected group, in the same manner as did the district selector and the office switch is then advanced into a position designated the "Talking" position, in which the T and R leads from the district are connected to the T and R terminals of the trunk which the office selector has selected.

In cases where an office selector is not used in completing a call the sender realizes that these selections are to be omitted. To this end a circuit is closed when the R2 switch enters positions 2/3 through the brush of the S0 translator arc in which the (S) relay operates. (See Figure 1). The (S) relay holds until the R1 switch advances beyond position 6. With the (S) relay operated the R1 switch is advanced from position 2 to position 7 during the time district group selection is being made, and the R2 switch cannot advance from position 3 to position 4 until the (S) relay releases. The release of the (S) relay when the R1 switch advances beyond position 6 advances the R2 switch to position 4. When the R1 switch enters position 7 the R2 switch is advanced to position 5 in which position the fundamental circuit is closed for "trunk test".

- SENDER CONTROL**
 SEQ. SW. (TS) RELS.
- 1 - 10 NORMAL AWGTG. (TS) RELS.
 - 2 - 11 DISTRICT SELECTION
 - 3 - 12 OFFICE BRUSH
 - 4 - 13 PASS BY
 - 5 - 14 OFFICE GROUP
 - 6 - 15 SELECTIONS BEYOND OFFICE.
 - 7 - 16 PASS BY
 - 8 - 17 AWGTG. RESTORE
 - 9 - 18 AWGTG. RESTORE

- SENDER R2**
 SEQ. SW. DISTRICT BRUSH
- 1 - NORMAL AWGTG. DISTRICT BRUSH
 - 2 - DISTRICT GROUP
 - 3 - OFFICE SELECTION
 - 4 - TRUNK TEST
 - 5 - TRUNK TEST

SENDER CIRCUIT

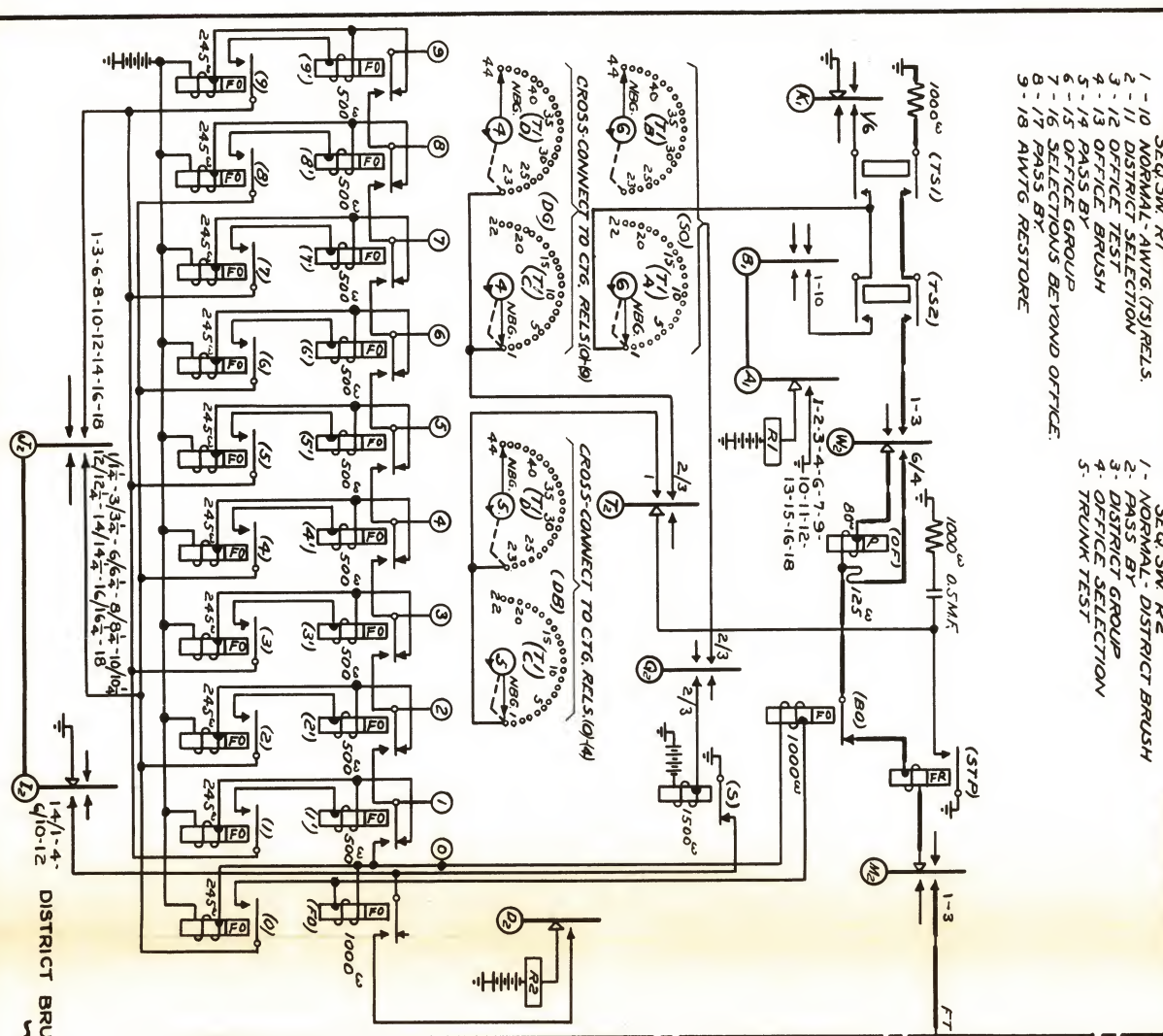

DISTRICT CIRCUIT

- DISTRICT**
 SEQ. SW. LINK
- 1 - AWGTG. LINK
 - 2 - AWGTG. CALL
 - 3 - AWGTG. SENDER
 - 4 - BRUSH SELECTION
 - 5 - AWGTG. SENDER
 - 6 - GROUP SELECTION
 - 7 - AWGTG. (L) RELAY

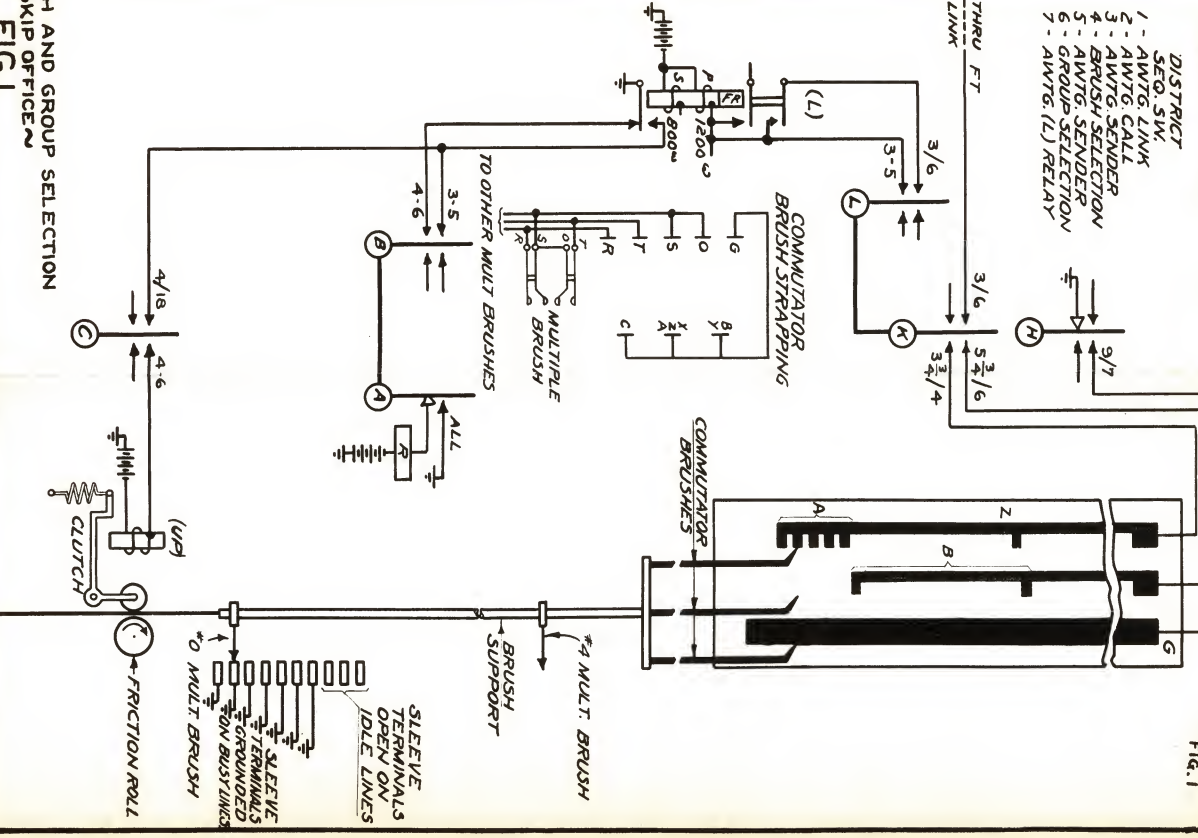
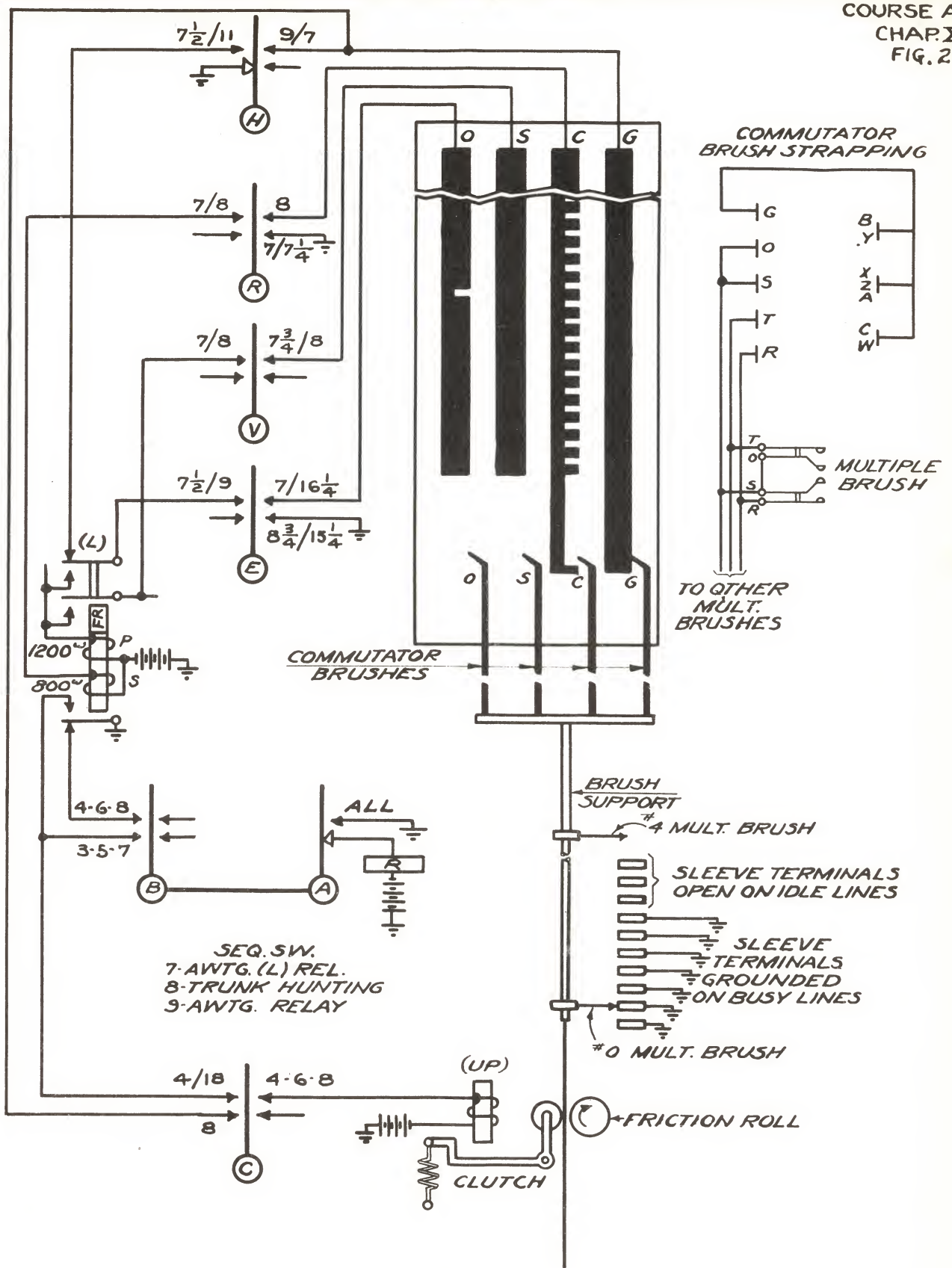
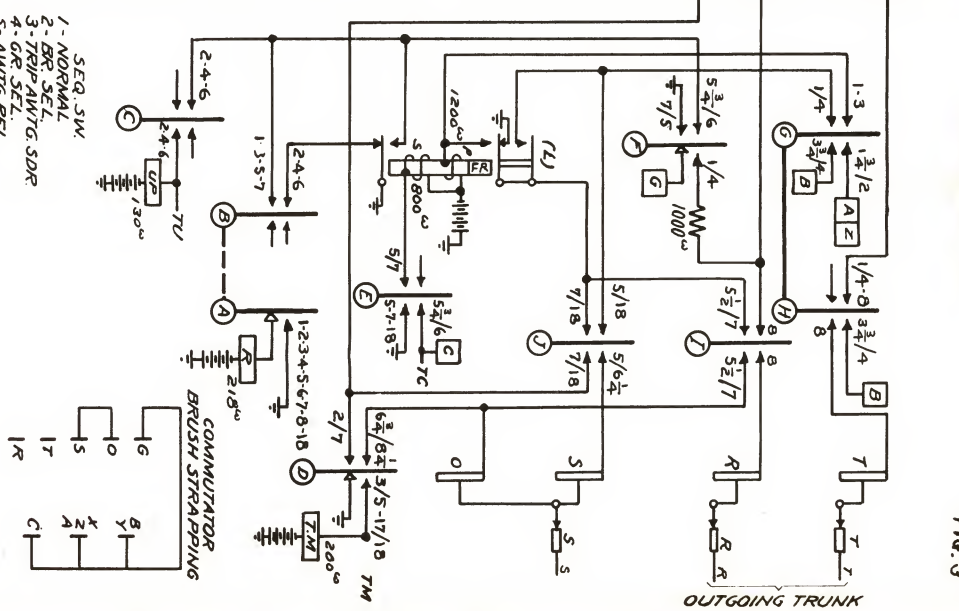

FIG. 1



TRUNK HUNTING CIRCUIT
 DISTRICT & OFFICE SELECTORS
 FIG. 2

OFFICE SELECTOR



- SEQ. SW.
 1 - NORMAL
 2 - BR. SEL.
 3 - TRIP AWTG. SDR
 4 - GR. SEL.
 5 - AWTG. REL.
 6 - TRK. HTG.
 7 - AWTG. REL.
 8 - TALKING
 10 - RETURN

SENDER

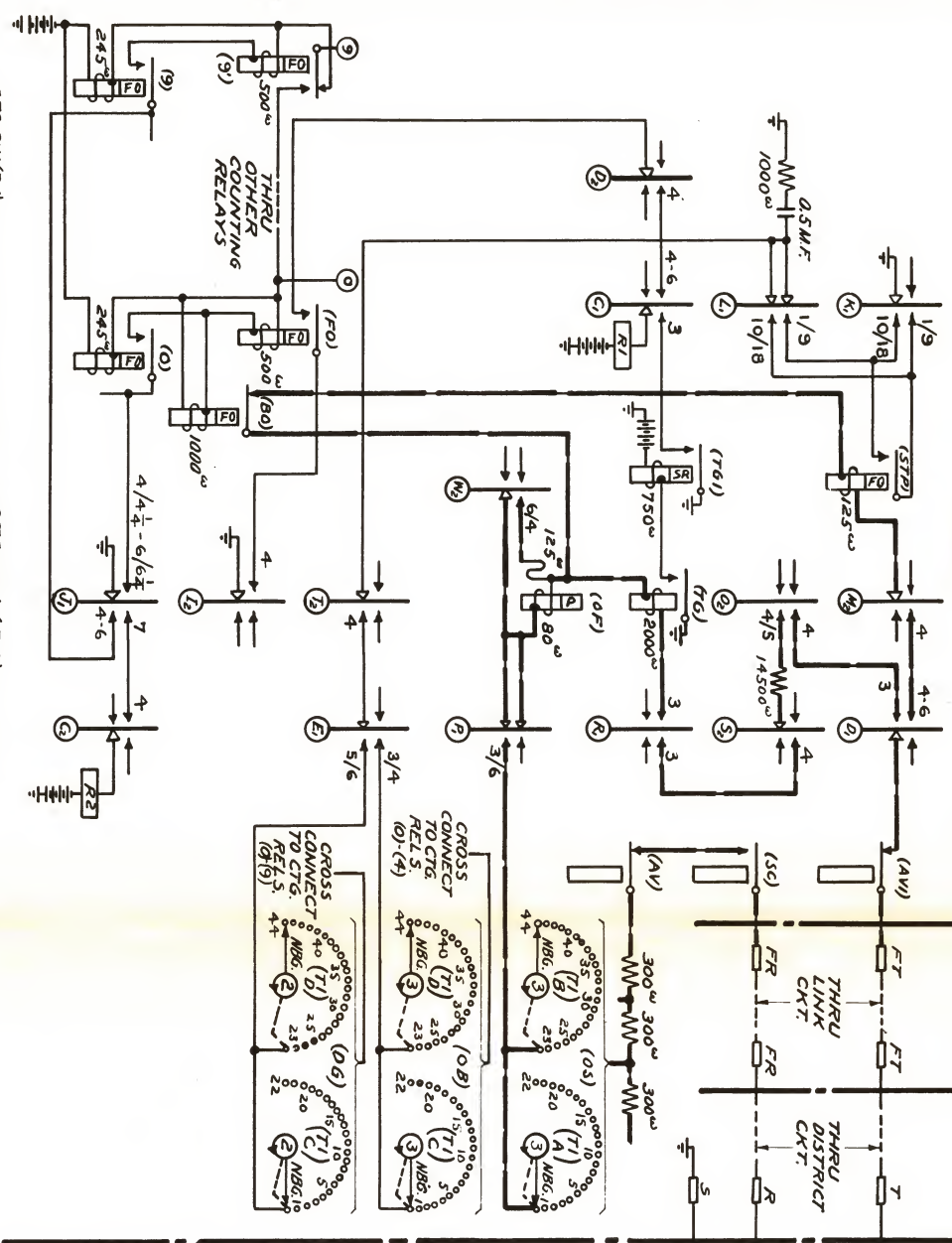

- SEQ. SW. (R-1)
 1 - 10 NORMAL AWTG. RELAYS
 (YELLOW STRIPE)
 2 - 11 DIST. SEL. AWTG. SDR
 3 - 12 OFFICE TEST
 4 - 13 BRUSH
 5 - 14 OFFICE GROUP
 6 - 15 PASS GROUP
 7 - 16 PASS BEYOND
 8 - 18 AWTG. RESTORE
- SEQ. SW. (R-2)
 1 - NORMAL DIST. BRUSH
 11 - AWTG. (S) RELAY
 (YELLOW STRIPE)
 12 - FINAL TENS
 13 - AWTG. (S) RELAY
 14 - OFFICE SELECTIONS
 15 - FINAL UNITS
 16 - TRUNK TEST
 17 - RCT. PULSES
 18 - INC. GROUP
 19 - INC. ADJ.
 20 - AWTG. (TA) REL.
 21 - TALK. PASS BY 18 TALK SELECTION
 22 - FINAL BRUSH

OFFICE TEST AND SELECTIONS
 3 WIRE
 FIG. 3

CHAPTER XII

TRUNKING SCHEME ON OUT TRUNKING FRAMES

Having described the district and local office frames and the operation of the selectors and sender during district and office selections, attention will now be given to the arrangement of outgoing trunks whereby all subscribers in the office are enabled to be connected with all destinations in the area. It is usually the case that traffic to other offices requires more than ten trunks in a group and where 90 trunks per group are required only office destinations could be taken care of. It is, therefore, evident that 450 trunks connected to a series of district frames in straight multiple would not be enough to take care of the trunking of the following theoretical exchange areas.

- 50 Offices - 10 Trunks to each office
- 10 Offices - 90 Trunks to each office
- 25 Offices - 10 Trunks to each of Five Offices
 - 20 Trunks to each of Five Offices
 - 30 Trunks to each of Five Offices
 - 60 Trunks to each of Five Offices
 - 80 Trunks to each of Three Offices
 - 90 Trunks to each of Two Offices

More trunks may be obtained either by "splitting" frames into more than one group from a trunking standpoint and by introducing office frames. The application of these methods is shown graphically in Fig. #1 associated with this Chapter. This figure illustrates a theoretical exchange area of 50 offices, which, on account of the number of offices and number of trunks to each office, requires the use of office frames. The requirements of small groups of trunks to miscellaneous destinations such as information operator, zero operator, AB toll, long distance, etc., will be ignored for the present in order to simplify the illustration used to explain the trunking scheme. This figure also shows the typical divisions of a bank of 100 terminals into eight groups of ten trunks each and two groups of five trunks each together with the over-flow terminal at the top of each group.

The seven line finder frames shown have a capacity of 400 lines and 60 line finders each, it being assumed that the calling rates and holding times of each group of 400 lines are such as to require 60 finders during

the busy hour. These 420 line finders are linked with 420 district selectors grouped on seven district frames. These district selectors must have access to groups of trunks to all destinations in the exchange area so that each one of the 2400 subscribers will be afforded the facility for being connected with any other subscriber in this area. Assume that the outgoing trunk requirements of the office to itself and to the other 49 offices in the area are as follows:

To Offices No.

	<u>No. of Trunks</u>	<u>Total Trunks</u>
1 (Local Trunks)	100	100
3, 4, 6, 7, 18, 19, 21, 22, 30, 31, 40, 41, 48, 49, and 50 each	30	450
2, 9, 10, 24, 25, 38, 44, 45 and 46 each	40	360
8, 13, 15, 16, 17, 23, 27, 28, 29, 33, 34, 35, 37, 39 and 47 each	20	300
5, 11, 14, 20, 32 and 43 each	10	60
12, 36 and 42 each	60	180
26	<u>50</u>	<u>50</u>
		<u>1500</u>

One hundred trunks are required to handle local calls to the subscribers in office No. 1. Since the trunk capacity of a group is 90 the 100 trunks are obtained by assigning the lower 50 trunks of bank #0 and by splitting the group of district frames between frames D-3 and D-4. A group of 50 trunks is thus multiplied to the #0 banks on frames D-1, D-2 and D-3 inclusive, and another 50 trunks is multiplied to the #0 banks on frames D-4 to D-7 inclusive. Thus the group of 100 trunks is split into two groups of 50 trunks each. The splitting of a large trunk group into smaller sub-groups permits taking care of more destinations on a given number of banks. It should be noted, however, that the use of sub-groups results in an inefficient use of trunks since a large group of 100 trunks, for example, can handle as much traffic as two groups of approximately 60 or 65 trunks each. Thus in the case of the local trunk requirements for office No. 1 the use of two groups of 50 is not strictly correct since the inefficiency of the small groups would require about 60 or 65 trunks in each one. The division into sub-groups of trunks local to the office is generally permissible but it is usually desirable to keep inter-office trunks in one group in order to avoid inefficient use of underground cable pairs. At times it may be economical to split groups of inter-office trunks on the district frames in

order to avoid the furnishing of office selectors or to reduce the number of office selectors required.

The 40 trunks to office No. 2 are multiplied to the remaining 40 sets of terminals in bank #0 on the seven district frames. The multiple terminals on district banks #1, #2, #3 and #4 terminate as office selectors on office frames. The remaining 48 offices are grouped in four zones. The offices included in each zone and the number of trunks required from the district frames to office selectors on office frames for each zone are as follows:

Zone 1 - Offices 3 to 17 inclusive - 120 office selectors.

Zone 2 - Offices 18 to 29 inclusive - 90 office selectors.

Zone 3 - Offices 30 to 41 inclusive - 90 office selectors.

Zone 4 - Offices 42 to 50 inclusive - 90 office selectors.

The office frames of each zone are separate and distinct from the office frames of any other zone. The group of 120 trunks from the district frames to the office selectors on office frames serving zone 1 are divided into two sub-groups A and B of 60 trunks each. The office selectors to which these trunks connect are located on office frames 0-1 and 0-2. The trunks in sub-group A are multiplied to the first 60 sets of terminal strips in bank #1 on district frames D-1, D-2 and D-3 and the trunks in sub-group B are multiplied to the first 60 sets of terminal strips in bank #1 on district frames D-4 to D-7 inclusive. The remainder of the #1 bank on the district frames are spare. The 90 trunks required from the district frames to each of zones #2, #3 and #4 are located in banks #2, #3 and #4 respectively on all of the seven district frames. The trunks to zone #2 are connected to office selectors on office frames 0-3 and 0-4; the trunks to zone #3 are connected to office selectors on office frames 0-5 and 0-6; and the trunks to zone #4 are connected to office selectors on office frames 0-7 and 0-8.

The inter-office trunks to the various offices included in each zone are multiplied to the banks of both frames which serve this zone. The distribution of the groups of trunks on the office frames to the various offices in each zone is shown in figure 1.

Suppose a call is originated by subscriber #2034 in office #1 for some subscriber in office #17. The calling line is found by a line finder on frame LF-6 and the sender which registers the call directs the district selector on

district frame D-6 (which is associated with this line finder) to bank #1 where this selector hunts for an idle trunk in sub-group B. The sender then directs the office selector (on frame 0-1 or 0-2 depending upon which trunk was chosen by the district) to group #4 in bank #4, where the office selector hunts in a group of 20 trunks for an idle trunk to office #17.

In like manner a call originated by subscriber #254 in office #1 for any subscriber in office #25 is found by a line finder on frame LF-1, and the associated district selector on frame D-1 is directed by the sender to select an idle trunk in bank #2. The office selector (on frame 0-3 or 0-4) which has thus been selected is then directed by the sender to hunt for an idle trunk to office #25 in group #4 of bank #3. If the same subscriber were to call a subscriber in office #19 a district trunk to office zone #2 would be picked as before, but the sender would, in this case, direct the office selector to select an idle trunk in group #3 of bank #0. A local call originated by subscriber #254 of office #1 would be directed by the sender through sub-group A, bank #0 directly to a local incoming selector on an incoming frame in the same office.

From this illustration the derivation of the names "district" and "office" is apparent, "district" being applied to selectors on frames which provide trunks to districts or zones of offices, and "office" being applied to selectors on frames which provide groups of trunks to the individual offices which are included in a given district or zone.

In an office layout in which district and office frames are used the larger groups of trunks should be placed on the district multiple and the smaller groups on the office multiple since this tends to decrease the number of office selectors which must be provided. On both frames the larger groups of trunks should be placed at the bottom of the bank thereby reducing the average time required for making group selection; this arrangement also permits making additions without disturbing the original trunk group and also tends to distribute wear evenly over all trunks of a group.

The trunks in a group or sub-group on the district or office multiple banks are not connected to the sets of terminal strips in the same order on each frame but are "slipped" in accordance with a definite plan. By "slip" is meant the changing of the relative position of the trunks in a group on each succeeding frame. The slip arrangements which has been commonly used for district or

office groups of 10, 20 and 30 trunks each is shown on Figure 2. In the case of the 30 trunk group the trunks appear in regular order on the first frame numbering from 0 to 29 beginning at the bottom. On the second frame the trunks number from 19-10, 20 to 29, and 9 to 0 in three layers beginning at the bottom. On the third frame the trunks number from 29 to 20, 9 to 0, and 10 to 19 in three layers beginning at the bottom. On the fourth frame the 30 trunks again appear in the regular order as shown for the first frame. This cycle is repeated throughout the entire number of frames on which the group or sub-group of trunks appear. This arrangement is now the standard only on the office frames and Figure 3 shows the arrangement now used on district frames. Graded multiple is used whereby a group of trunks is composed of three classes known as individual, convertible, and common trunks. All groups whether graded or non-graded are slipped in layers of 5 trunks each instead of being slipped in layers of 10 trunks each.

The sets of terminal strips in a bank on one frame are multiplied to the corresponding sets of terminal strips on the next frame by a short multiple cable which is fanned out and connected directly to the multiple strips. Each cable connects 20 sets of terminals. Formerly the multiple cables connected to terminals on terminal strips mounted on the end of the frame, but the soldering lugs on the multiple strips are now made heavier and the cable connects directly thereto.

Where office selectors are not used the multiple terminals on the district frames are cabled to the vertical side of a "district distributing frame" (DDF) and cross-connected to the horizontal side of the same frame. Those trunks which connect to outgoing interoffice trunks are cabled from the horizontal side of the DDF to the horizontal side of the MDF, cross-connected to the vertical side of the MDF, and there connected to the pairs of the outgoing trunk cable. Those trunks which go to local information operator, the local trouble desk, etc., are cabled from the horizontal side of the DDF to the equipment involved.

Where office selector frames are used there are three methods of cabling from the district and office multiple. Usually a "trunk distributing frame" (TDF) is used and the multiple bank terminal strips on both the district and office frames are connected to the vertical side of the TDF, and cross-

connected to the horizontal side of the same frame. From here the outgoing trunks are cabled to the horizontal side of the MDF and cross-connected to the pairs of the outgoing trunk cable. The trunks from the district frame which terminate in local office selector circuits are cabled from the horizontal side of the TDF to terminal strips on the end of the office selector frames. The other miscellaneous local trunks are cabled from the horizontal side of the TDF to the equipment units on which they terminate. By the second method of cabling a TDF is not used. In this case the multiple terminals on the district frames are connected to the vertical side of a DDF as described for the case above where no office selectors were required. The multiple terminals on the office frame are connected directly to the horizontal side of the MDF and there cross-connected to the pairs of the outgoing trunk cable. By the third method two distributing frames are used, the one a "district distributing frame" (DDF) and the other an "office distributing frame" (ODF). These two frames together serve the same purpose as the TDF in the first method mentioned. This method is very seldom used. In any case the method used is the one which is the most economical and efficient, taking into account the number of out-trunking frames and their location with respect to the distributing frame equipment.

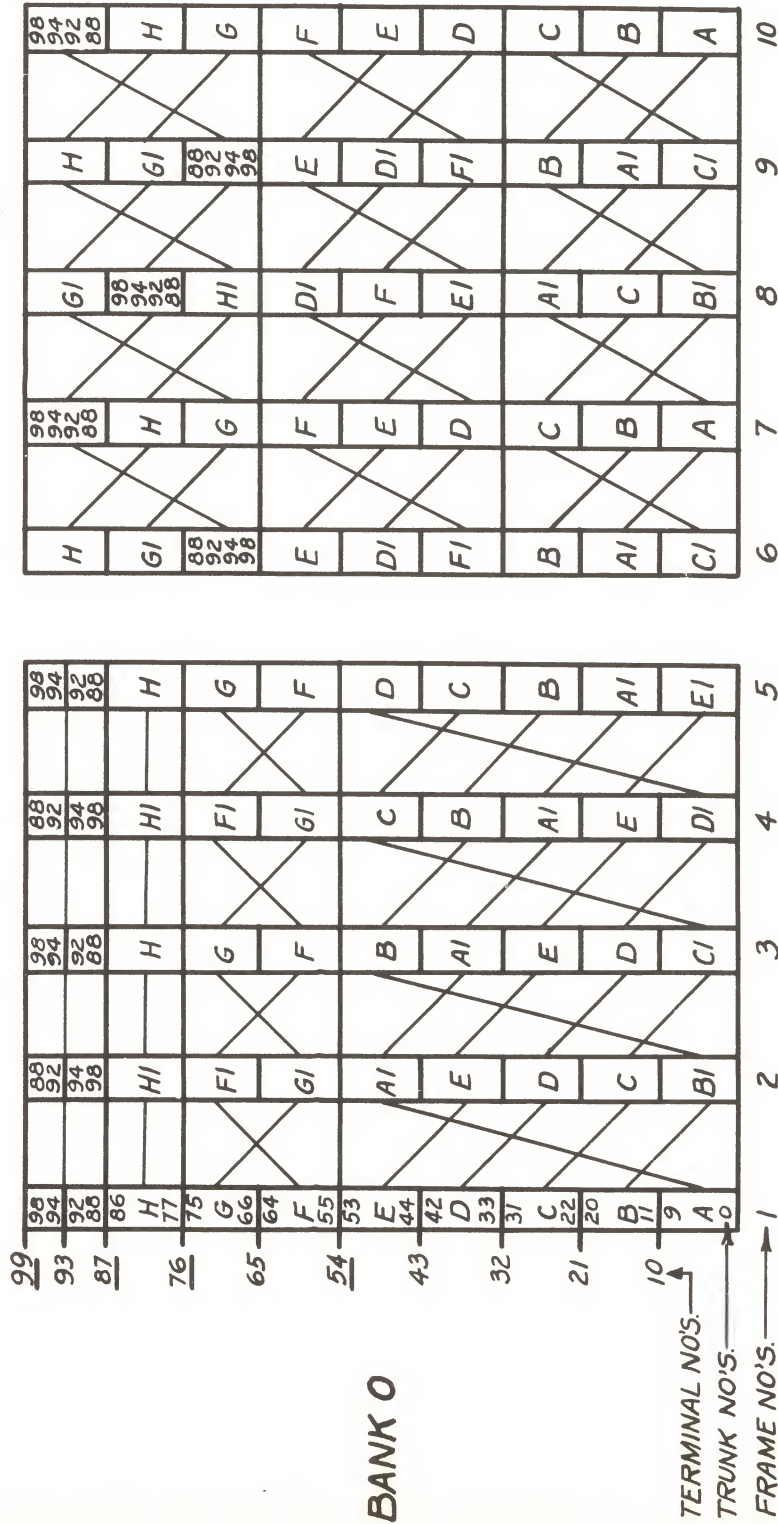

NOTE: LETTERS A, B, C, ETC., INDICATE BOTTOM UP NUMBERING OF TRUNKS, AND LETTERS A1, B1, C1, ETC., INDICATE TOP DOWN NUMBERING OF TRUNKS.

**TYPICAL SLIP ARRANGEMENT
 FOR OFFICE FRAME OUTGOING TRUNK MULTIPLE
 FIG. 2**

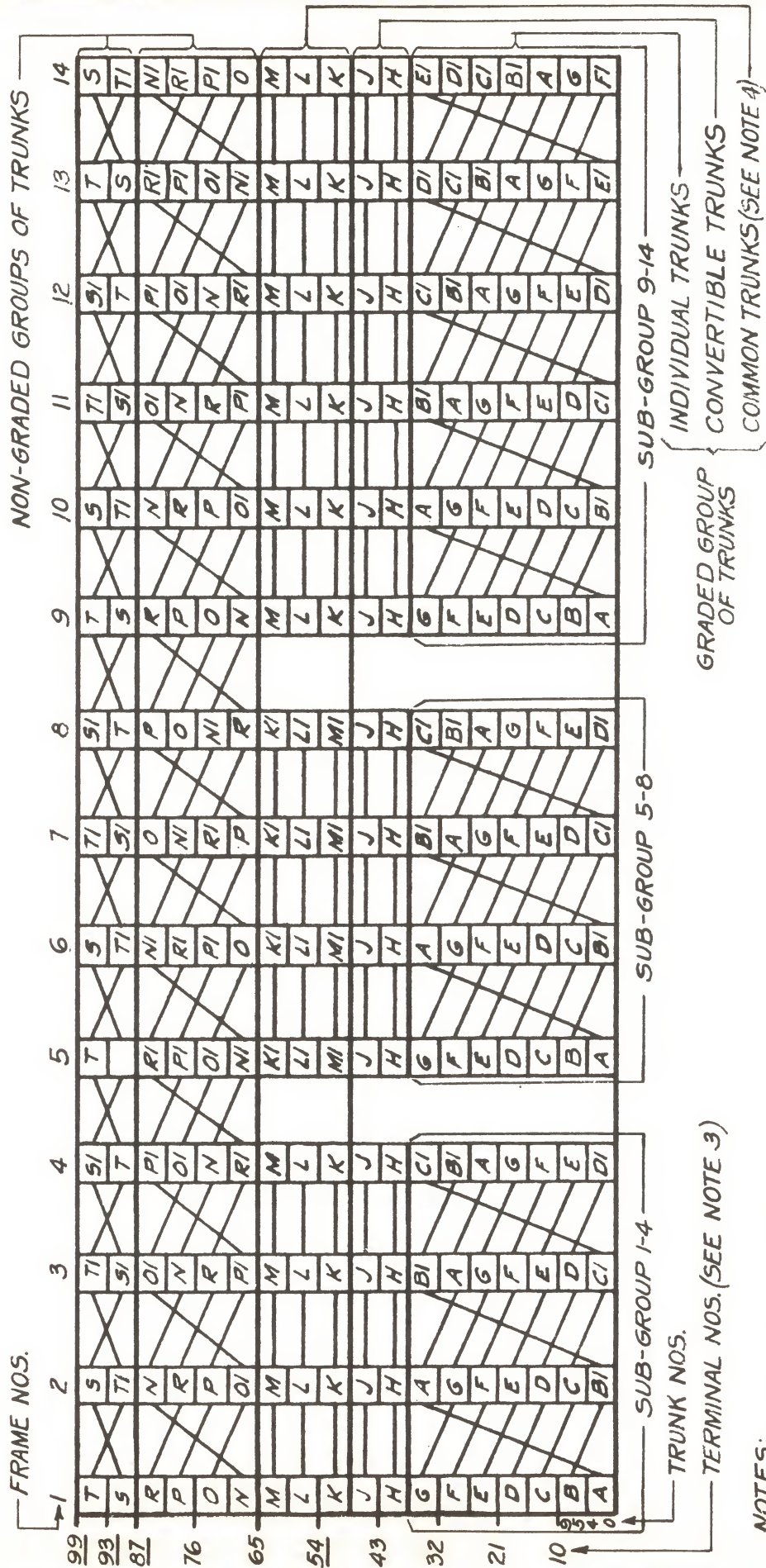

- NOTES:
- 1- LETTERS A,B,C, ETC., INDICATE BOTTOM-UP NUMBERING OF TRUNKS AND LETTERS AI, BI, CI, ETC., INDICATE TOP-DOWN NUMBERING OF TRUNKS
 - 2- EACH GROUP OF GRADED TRUNKS CONSISTS OF THREE CLASSES, KNOWN AS, INDIVIDUAL, CONVERTIBLE AND COMMON TRUNKS.
 - 3- TERMINAL NUMBERS UNDERLINED REPRESENT OVERFLOW, THOSE NOT UNDERLINED REPRESENT SPARE OVERFLOW.
 - 4- REVERSED BETWEEN FRAMES 4 & 5 AND 8 & 9 AT DISTRICT DISTRIBUTING FRAME, SUB-GROUP 1-14.

METHOD OF SLIPPING O.G.T. MULTIPLE
 ON DISTRICT FRAMES
FIG. 3

CHAPTER XIII
IN TRUNKING - SCHEME AND FRAMES

On calls between subscribers in panel type offices, the trunk selected by the office or district selector in the originating office terminates either in a "local incoming selector" circuit in the same office or an "interoffice incoming selector" circuit in a distant office. Incoming selectors are necessary in a panel office not only for completing calls which originate in the same and other panel type offices but for completing calls which originate in manual and toll offices. We have, therefore, several kinds of incoming selectors differing from each other according to the type of equipment used in the office from which the trunk comes. For the present, the incoming selector with which we are concerned is the one used in completing calls which originate in panel type offices. The equipment of which an incoming selector is composed is mounted on an "incoming" frame. Incoming frames differ very little with the kind of incoming selectors which are mounted thereon.

The incoming selector in which the selected trunk terminates must be able to complete a connection to any line in the office. Since the incoming frame on which this selector is mounted has a capacity of only five 100 point banks, it is manifestly impossible for all of the 10,000 subscribers' lines to be directly accessible to each incoming selector. To secure this accessibility indirectly, the 10,000 subscribers' lines are divided into twenty groups of 500 lines each. A group of 500 subscribers' lines are terminated on five 100 point banks mounted on a panel type selector frame. This frame is known as a "final frame" and the selectors mounted thereon are called "final selectors". Each final selector has access to 500 subscribers' lines and enough final selectors are provided to carry the busy hour traffic which terminates in this group of lines. The final selectors are multiplied to the terminal strips in the banks on the incoming frames. Every incoming selector must be able to complete a call to a line in any one of the 20 groups, and to this end each of the five banks on the incoming frame are divided into four groups of 25 sets of terminals as shown in Figure 1. The top set of terminals in each of these four groups is used as an "overflow terminal", leaving 24 sets of terminals in each of the 20 groups on incoming frames which connect to final selectors. With this arrangement all incoming selectors have access through the 20 groups of final selectors to all of

the 10,000 lines.

Trunk groups on the incoming frame cannot be combined when the traffic to any one of the final choices exceed that which can be carried by 24 trunks, for if this were done an incoming selector would be unable to reach all of the 20 groups of 500 lines. When more than 24 trunks, that is final selectors, are required to carry the incoming traffic to a group of 500 lines, it is necessary to divide these final selectors into subgroups of not more than 24 selectors each. The incoming frames are similarly divided into subgroups, with respect to the trunk multiple to which these final selectors are connected, and the final selectors in each subgroup are multiplied only to those incoming frames which are in the same subgroup. For instance, if the traffic is uniformly distributed to all of the 20 final choices in a fully equipped panel office, and each choice requires 48 trunks, the incoming frame multiple to each choice is divided into two subgroups. The traffic originating through the incoming frames in subgroup (A) is completed over trunks to final selectors in subgroup (A) and the traffic to the same group of 500 lines which originates through the incoming frames in subgroup (B) is completed over trunks to final selectors in subgroup (B). To obtain proper subgrouping of incoming frame multiple and final selectors it is sometimes necessary to employ split banks on the incoming frames. Where the distribution of traffic to the various final choices is not uniform the subgrouping of the incoming frame multiple will not be the same to the various choices. An illustration of irregular subgrouping occurs in Pennsylvania office where 300 final selectors are required to carry the traffic to one group of 500 lines; and it is necessary to split the incoming multiple to this choice in 13 subgroups, while the majority of the remaining choices require but 120 trunks or 5 splits in the incoming multiple.

The trunking scheme used in office No. 1 of the same theoretical area of 50 offices as was considered in the out trunking scheme in a previous chapter is shown in Figure 6. There are nine incoming frames divided into three subgroups so that the final selectors which serve any one of the 20 groups of 500 lines are similarly divided into three subgroups. The final selectors in subgroup A are connected to the multiple on incoming frames I-1, I-2 and I-3, the final selectors in subgroup B are connected to the multiple on incoming frames

I-4, I-5 and I-6, and the final selectors in subgroup C are connected to the multiple on incoming frames I-7, I-8 and I-9. Provision is made for 60 or more trunks to each of the 20 final choices, or groups of final selectors serving 500 lines. The trunks to the final selectors which serve lines 0 to 499 and the trunks to final selectors which serve lines 9500 to 9999 are shown in detail; in each of these cases 24 trunks are multiplied to the incoming frames in subgroup A, 24 to the frames in subgroup B, and 12 to the frames in subgroup C. The other 12 sets of terminals in group 0 of bank 1 and in group 3 of bank 4 on the incoming frames in subgroup C are spare.

When more than 60 trunks are required to handle the traffic to a group of 500 lines, additional final frames are provided and the subscriber's multiple is extended to the banks on the additional frame or frames. When the total number of final selectors required for a group of 500 lines does not exceed 90, the multiple banks on the additional frame are split vertically in the middle so that one half of the selectors on the frame are used for one group of 500 lines, and the other half may be used for another group of 500 lines. This condition is illustrated by the addition of split frame F21 on which are located 12 additional selectors, a total of 72 trunks being required to carry the incoming traffic to each of the groups of subscribers' lines 2000 to 2499 and 2500 to 2999, respectively. In this case, the terminal strips on one half of frame F21 are multiplied to the terminal strips on frame F4 and the terminal strips on the other half of frame F21 are multiplied to the terminal strips on frame F5. When the number of additional selectors required is greater than 30, a whole final frame of 60 selectors is added. In business and hotel areas where the incoming traffic is very heavy, it is frequently necessary to furnish two final frames for a group of 500 lines. As already mentioned it was necessary to furnish 300 final selectors on 5 final frames in Pennsylvania office to care for the traffic to a particular group of 500 subscribers' lines. Sketch A in figure 6 shows the typical division of an incoming bank of 100 terminals. As in the case of the district and office frame banks, these divisions are made on the commutator, and in the wiring attached to the bank. The slip arrangement shown in figure 7 is used for the incoming multiple and is similar to that used for the trunks on office frames except that the trunks are slipped in groups of four instead of in groups of 10.

The incoming frame, shown in figures 2 and 3, is very similar to the district frame. The multiple banks, as previously mentioned, are divided into only four groups of trunks by the spacing of the metal segments on the "B" and "X" commutator bars. Since trunk groups cannot be combined, as on the district frame, there is no "O" bar on the incoming commutator and the "S" bar is made so as to be open in the overflow positions. An additional commutator bar, designated "P", is required for use in controlling the ringing of the called subscriber where four party service is furnished. The incoming selector contains supervisory and transmission equipment for the incoming end of the trunk as does the district selector for the outgoing end of the trunk. This equipment consists of condensers and repeating coils which is now mounted on the incoming frame, although formerly the practice was to mount this equipment on repeating coil racks. The trunks from the incoming frame are cabled directly from the incoming multiple strips to terminal blocks on the end of the final frame. Two 12 circuit cables are run from each group on the incoming bank, one connecting the odd numbered terminals of the incoming group to the odd numbered selectors on the front of the final frame, and the other connecting the even numbered terminals in the incoming group to the even numbered selectors on the rear of the final frame. This method insures continuity of service from an incoming frame to a group of 500 subscribers even though one of the drive motors on a pair of final frames should stop. Four 25 circuit multiple cables per bank are required between incoming frames in the same subgroup and these cables connect directly to the multiple terminal strips.

The final frame, shown in Figures 4 and 5, is also very similar to the district frame. The final commutator does not have a "O" bar and the "B" and "Z" segments are so spaced as to divide each multiple bank, to which 100 subscribers' lines are connected, into ten groups of ten terminals each, there being no overflow terminals. The subscribers' lines are cabled from the H side of the IDF to terminal strips mounted on the end of the final frame and from there connected to the strips in the multiple banks. The multiple brushes differ from those used on trunk hunting selectors in that the sleeve brush is non-bridging so that it breaks contact with the sleeve terminal of one set before

it makes contact with the sleeve terminal of the next set. The final selector relay bay is not as wide as that on district or incoming frames since it does not include supervisory or transmission equipment. The clutch on the final frame includes two up-drive magnets, one designated HS (high speed) and the other LS (low speed). The HS magnet is used to drive the elevator upward during brush and tens selections; the LS magnet is used to drive it upward, during units selection and during PBX trunk hunting, at a rate of 15 terminals per second.

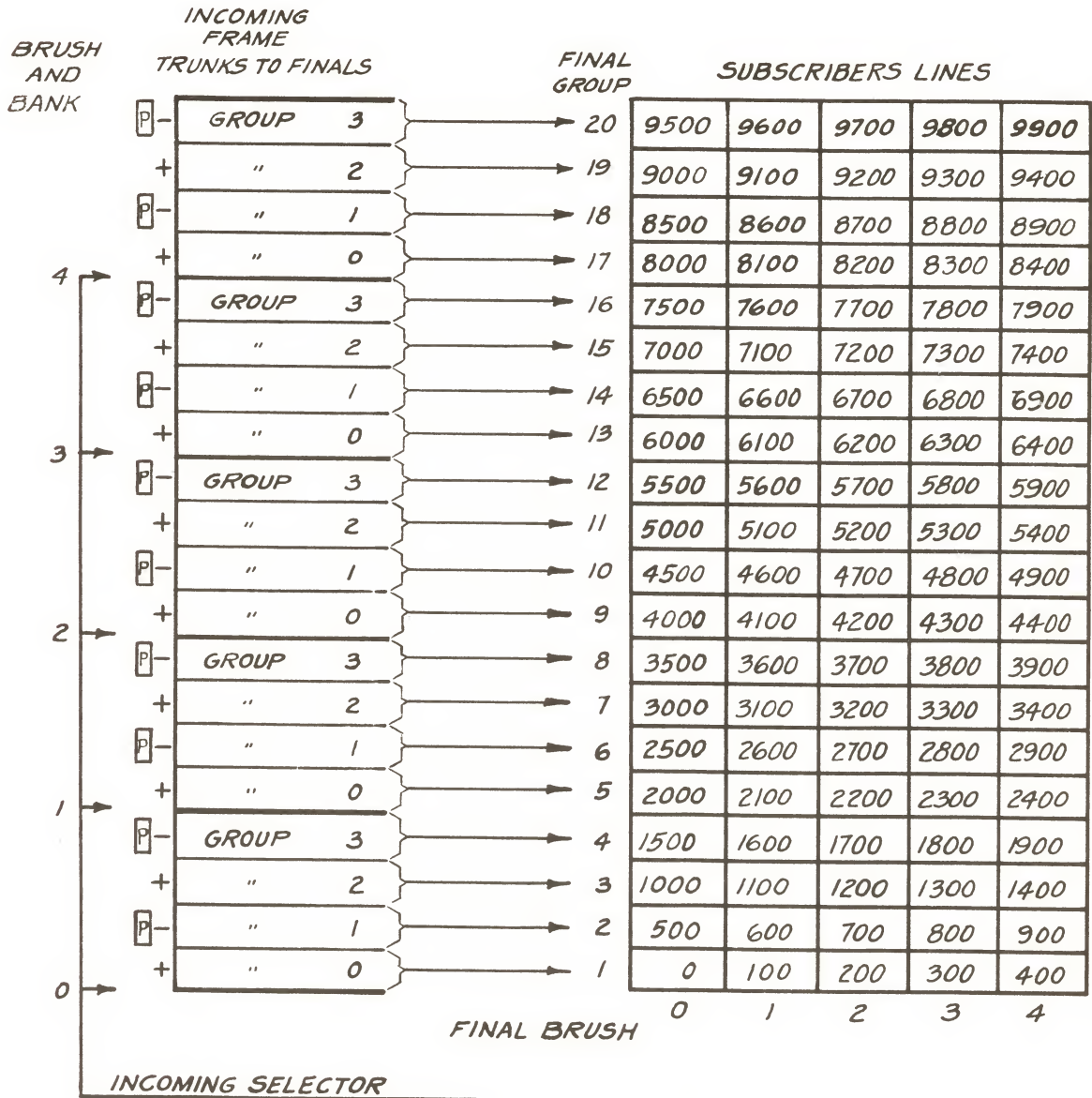

SCHMATIC OF NUMERICAL TRANSLATION
 FIG. 1

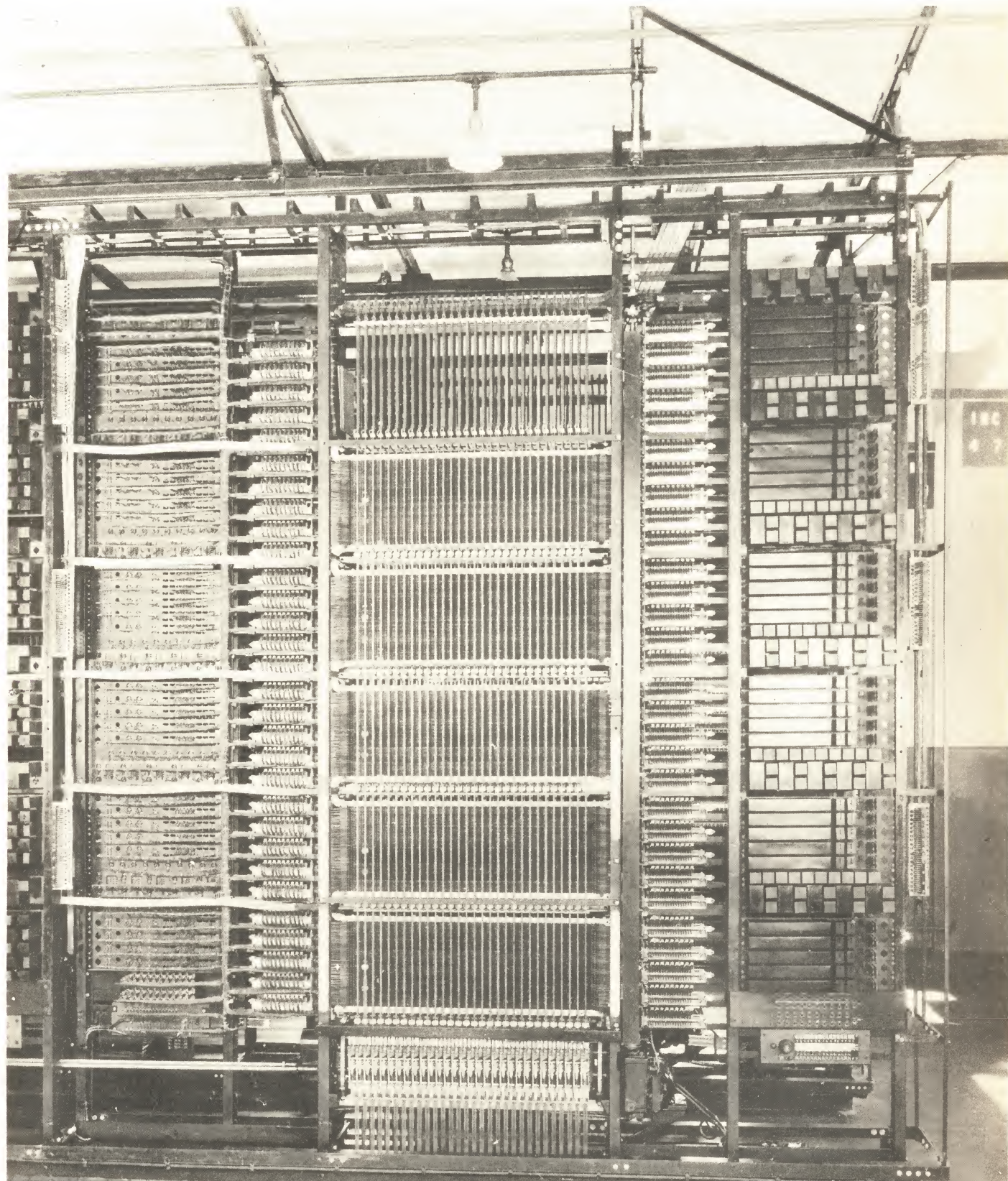

INCOMING SELECTOR FRAME
FIG. 2

26000

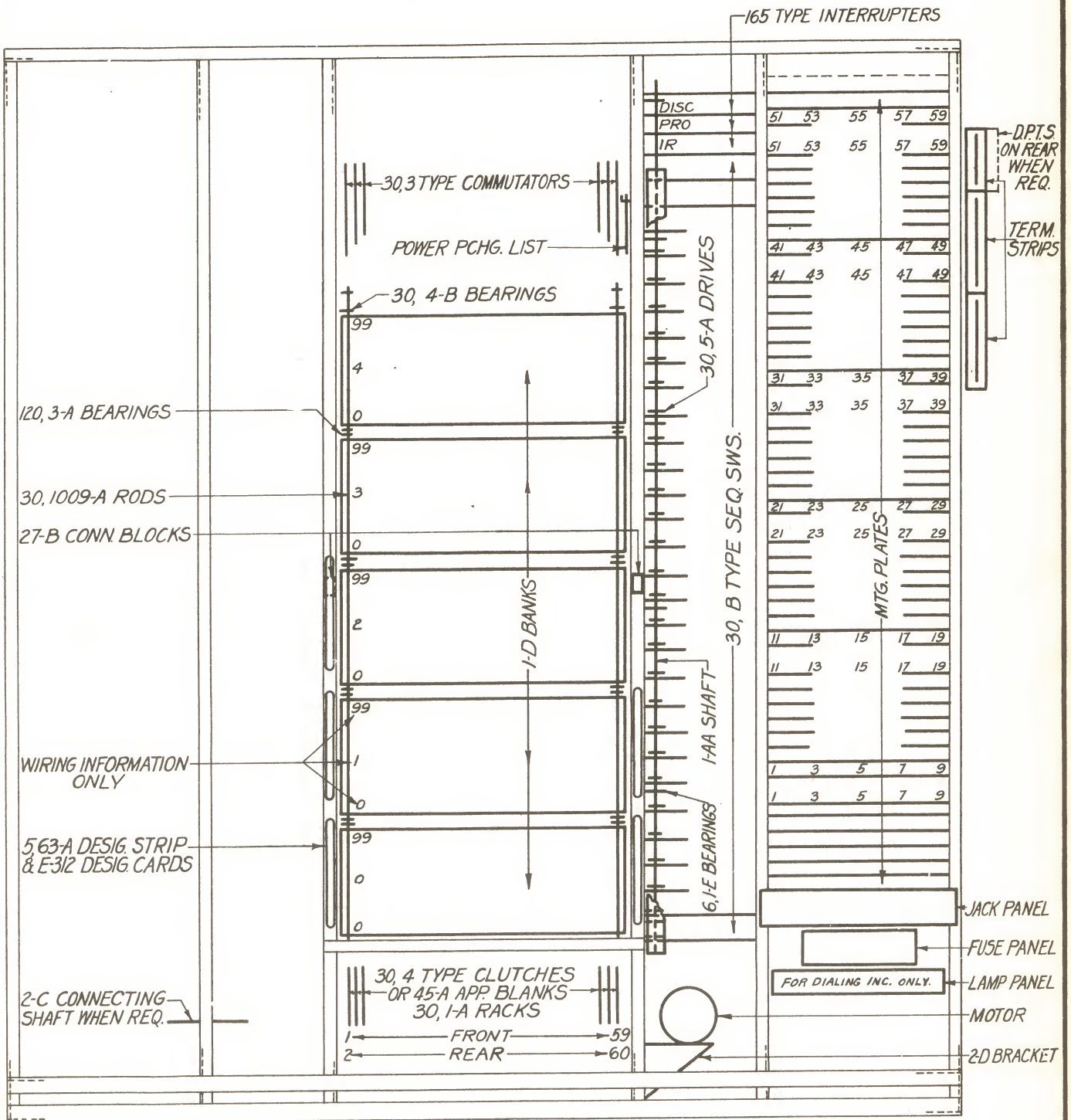

INCOMING FRAME
 FIG. 3

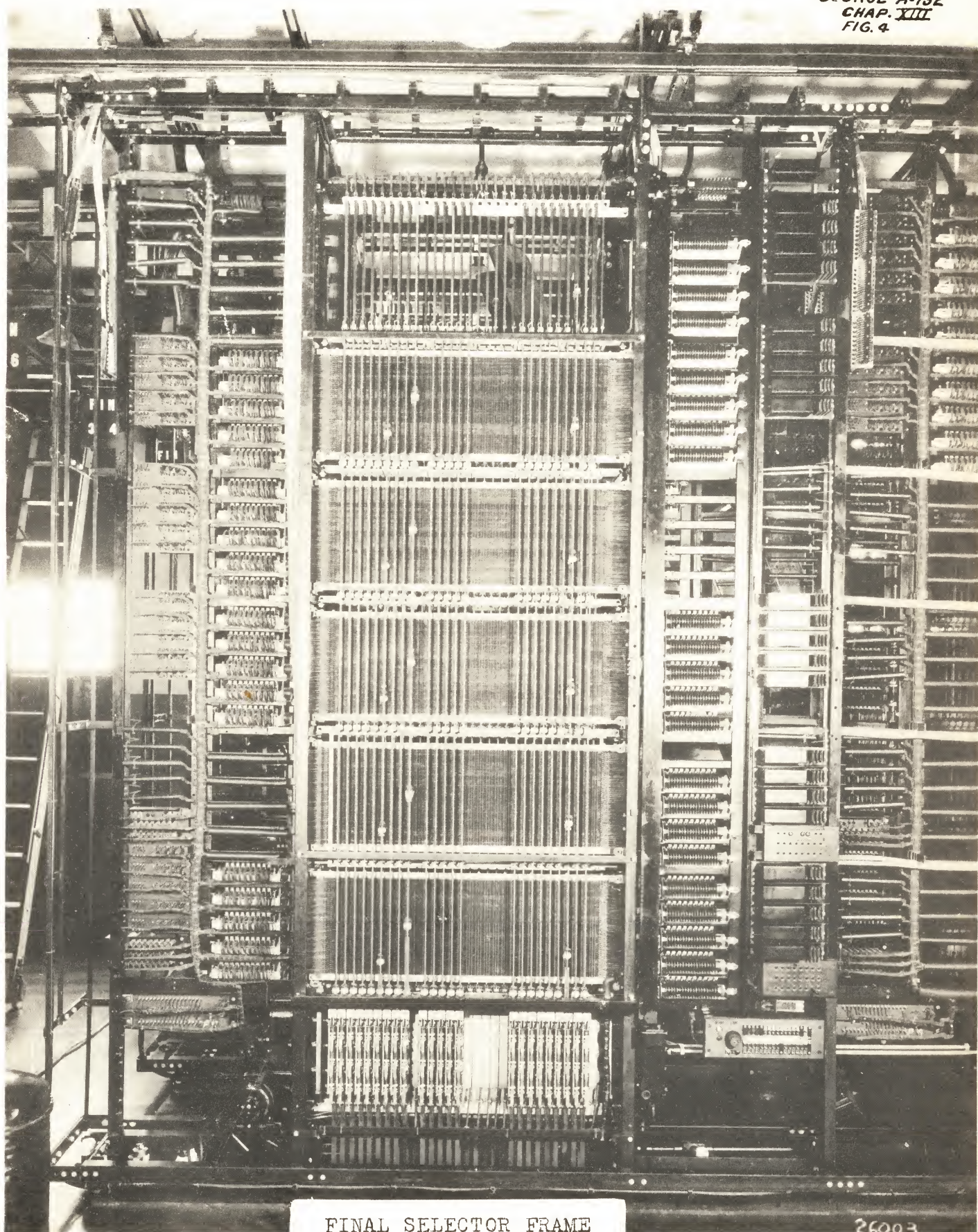

FINAL SELECTOR FRAME

FIG. 4.

26003

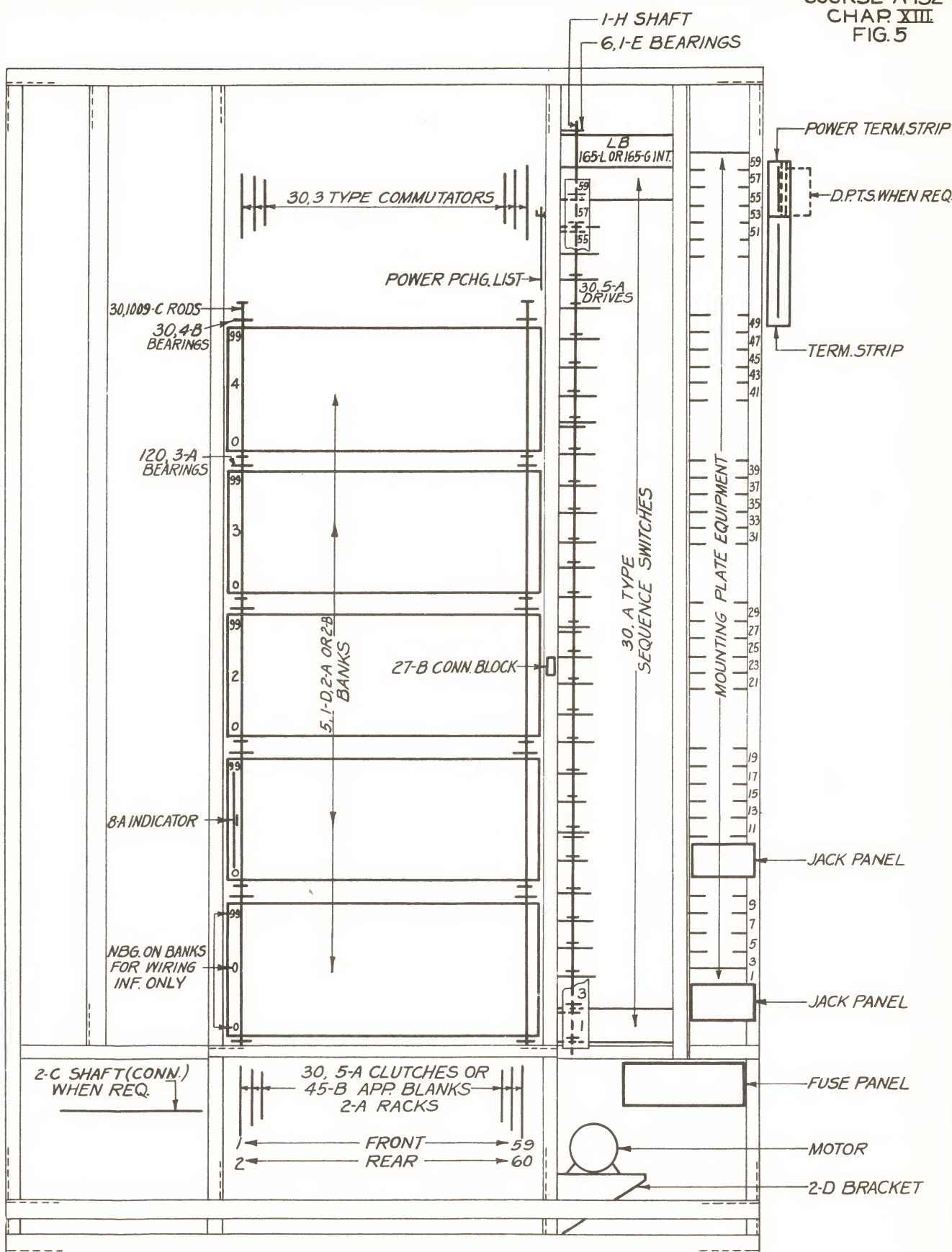

FINAL FRAME
 FIG. 5

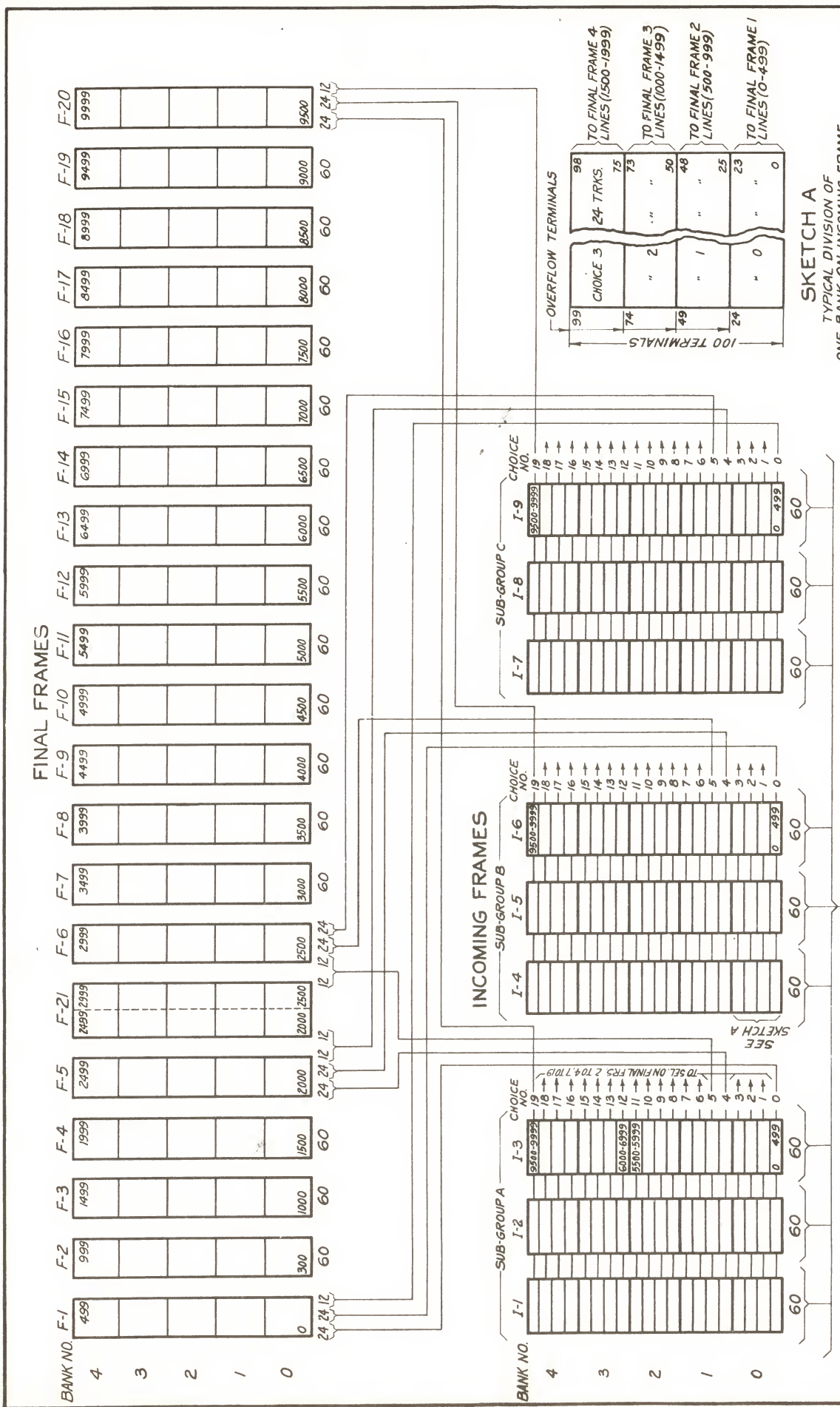

SKETCH A
 TYPICAL DIVISION OF
 ONE BANK ON INCOMING FRAME

TRUNKS TERMINATING AS INCOMING SELECTORS
 INCOMING FROM 50 FULL MECHANICAL OR MANUAL OFFICES
 EITHER ON A FULL MECHANICAL, CORDLESS OR KEY INDICATOR BASIS
 NON-GRADED MULTIPLE

INCOMING SCHEMATIC - PANELTYPE OFFICE
 THEORETICAL EXCHANGE AREA OF 50 OFFICES
FIG. 6

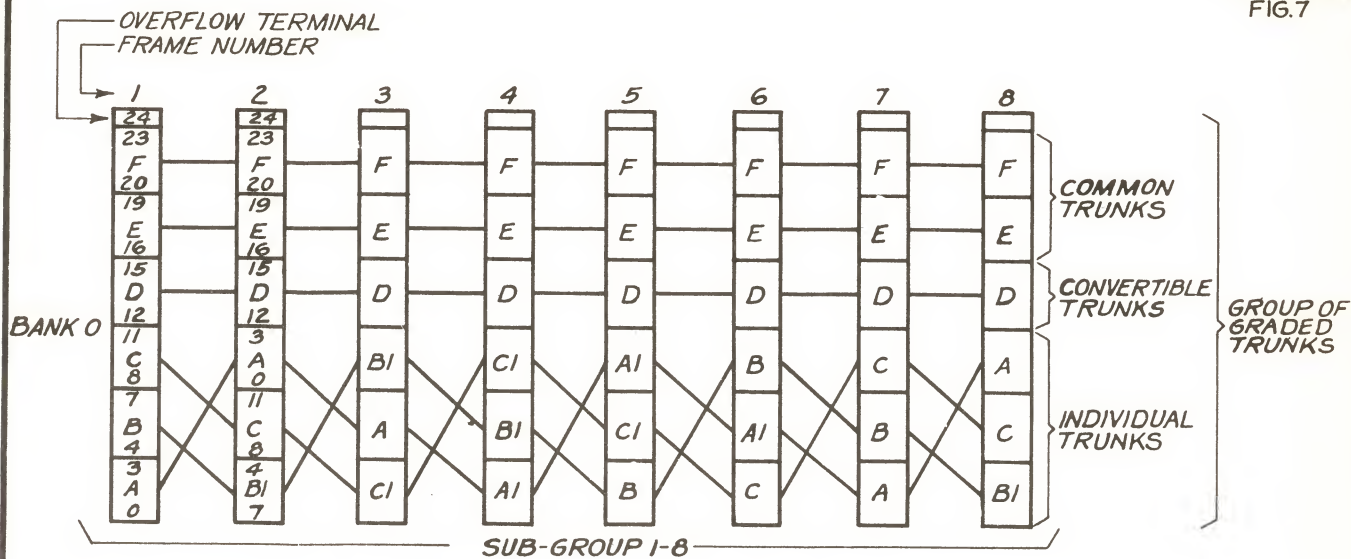

TYPICAL VIEW SHOWING SLIP NUMBERING BETWEEN FRAMES FOR GRADED TRUNKS

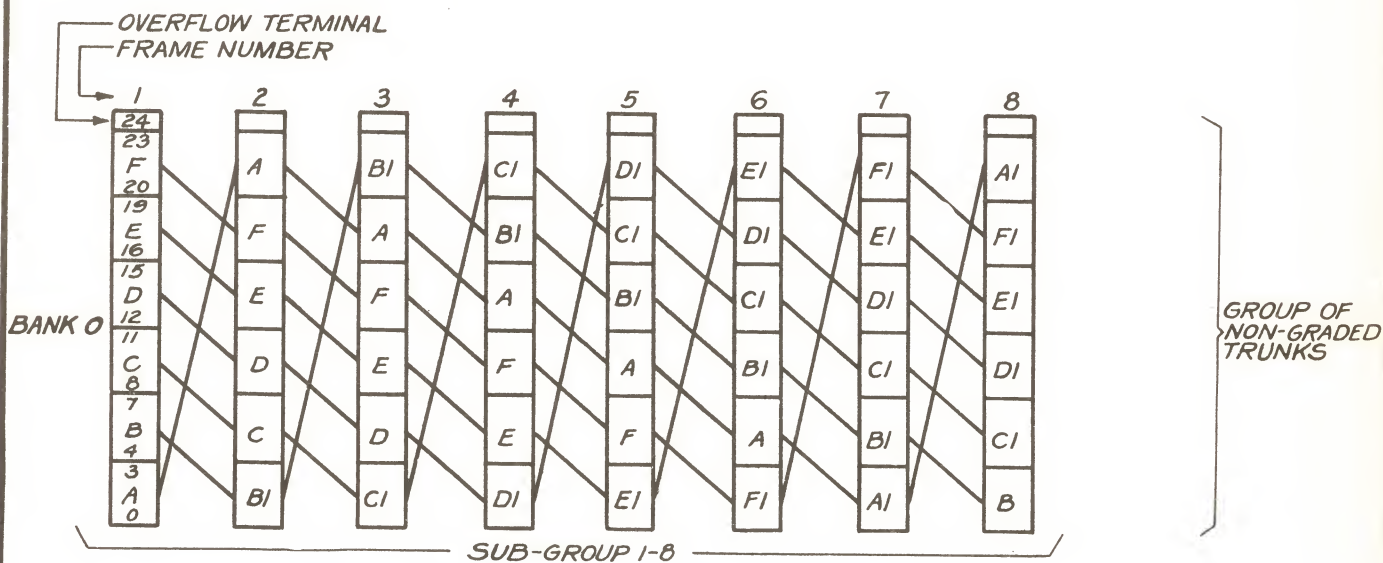

TYPICAL VIEW SHOWING SLIP NUMBERING BETWEEN FRAMES FOR NON-GRADED TRUNKS

NOTES:

- 1- LETTERS "A", "B", "C" ETC., INDICATE BOTTOM-UP NUMBERING OF TRUNKS, AND LETTERS "AI", "BI", "CI" ETC., INDICATE TOP-DOWN NUMBERING OF TRUNKS.
- 2- EACH GROUP OF GRADED TRUNKS CONSISTS OF THREE CLASSES KNOWN AS INDIVIDUAL, CONVERTIBLE AND COMMON TRUNKS. THE INDIVIDUAL TRUNKS ARE SLIPPED IN LAYERS OF FOUR TRUNKS EACH.

METHOD OF SLIPPING O.G.T. MULTIPLE ON INCOMING FRAMES

FIG. 7

CHAPTER XIV

COMPLETING A MECHANICAL CLASS CALLIncoming Selections and Trunk Hunting

Those parts of the sender and selector circuits which are used during trunk test and in completing incoming and final selections are shown schematically in Figures 1 and 2. With the district selector sequence switch in the "selection beyond" position (and, when an office selector is used, with the office selector sequence switch in the "talking" position), the fundamental circuit is closed for trunk test as soon as the sender R1 switch enters position 7 and the sender R2 switch enters position 5, providing the CL relay has released. The trunk test circuit is held open by operation of the (S) relay until after the class switch is set and the (CL) relay released because the trunks which are selected on the various classes of call present different normal conditions to the sender for test. On a mechanical class call the (S) relay is also held operated until the RC switch has been advanced beyond terminal 3 so that the sender cannot proceed with trunk test and incoming brush and group selections until the TH and H registers have been set. With the incoming selector in its normal position, the sender (TG) relay operates and the incoming (L) relay does not operate in the trunk test circuit, which is traced from battery through one winding of the incoming (L) relay, over the T lead of the interoffice trunk (assuming an interoffice call), through the office (when used) and district circuits, over the FT lead through the link and into the sender, through the 14,500 ohm resistance, back contact of the (S) relay, windings of the (TG) and (OFL) relays, BO translator brush and arc, compensating resistance, back over the FR lead through the link and district circuits, over the R lead through the office circuit (when used), over the R lead of the interoffice trunk, to ground in the incoming circuit. The operation of the (TG) relay operates the (TG-1) relay thus advancing the R2 switch to position 6.

The fundamental circuit is closed by the sender for incoming brush selection when the R2 switch is in position 6 and for incoming group selection when the R2 switch is in position 8. The incoming (L) relay is connected to the fundamental circuit for brush and group selections in positions 1 and 3 of the incoming switch, the operation of the (L) relay in each case advancing the switch to positions 2 and 4 in which the UP magnet is energized and the selector

driven upward. The TRIP magnet (TM) is operated in positions 3/4 thus tripping the selected brush when the selector moves upward. When the sender is satisfied for these selections by ground pulses from the "A" and "B" commutator segments, the sender opens the fundamental circuit, releasing the incoming (L) relay and advancing the sender R2 switch to positions 8 and 10, respectively. The release of the (L) relay in each case advances the incoming switch to positions 3 and 5 respectively. The circuits in which the counting relays operate for these selections are controlled by the setting of the TH and H registers.

Thus for brush selection the (0) counting relay is the first to be operated and the No. 0 brush is selected when the TH register is set on either of terminals 0 or 1; the (1) counting relay is the first to be operated and the No. 1 brush is selected when the TH register is set on either of terminals 2 or 3; the (2) counting relay is the first to be operated and the No. 2 brush is selected when the TH register is set on either of terminals 4 or 5; the (3) counting relay is the first to be operated and the No. 3 brush is selected when the TH register is set on either of terminals 6 or 7; and the (4) counting relay is the first to be operated and the No. 4 brush is selected when the TH register is set on either of terminals 8 or 9. When the H register is set on one of terminals 5 to 9, inclusive, the incoming group (IG) relay is operated otherwise this relay remains normal. For group selection the (0) counting relay is the first to be operated and the No. 0 group is selected when the TH register is set on an even numbered terminal and the H register set on one of terminals 0 to 4, inclusive; the (1) counting relay is the first to be operated and the No. 1 group is selected when the TH register is set on an even numbered terminal and the H register is set on one of terminals 5 to 9, inclusive; the (2) counting relay is the first to be operated and the No. 2 group is selected when the TH register is set on an odd numbered terminal and the H register is set on one of terminals 0 to 4, inclusive; and the (3) counting relay is the first to be operated and the No. 3 group is selected when the TH register is set on an even numbered terminal and the H register is set on one of terminals 5 to 9, inclusive.

The release of the incoming (L) relay when the sender is satisfied

for incoming group selection advances the incoming switch to position 5, in which position the (L) relay operates in local circuit advancing the switch to position 6 for trunk hunting. The trunk hunting circuit is shown in Fig. 2 and the operation is similar to that previously explained for district trunk hunting. When the incoming (L) relay releases after the idle trunk has been selected, the incoming switch is advanced to position 7. In position 7 the (L) relay reoperates in local circuit and locks over the "R" lead of the selected trunk to ground in the final selector circuit to which this trunk connects. The operation of the incoming (L) relay, advances the incoming switch to position 8 in which position the "T" lead of the incoming trunk is connected through to the "T" lead of the final selector circuit and the "R" lead of the incoming trunk is connected to ground through the make contact of the incoming (L) relay.

Final Selections

With the incoming selector switch in position 8 the final selector (L) relay is connected to the fundamental circuit in positions 1, 3 and 5 of the final switch, the operation of the (L) relay in each case advancing the final switch to positions 2, 4 and 6, respectively. With the (L) relay held operated the high speed (HS) magnet is operated in positions 2 and 4 final brush and tens selection respectively, and the low speed (LS) magnet is operated in position 6 final units selection, driving the selector upward in each of these positions. The TRIP magnet (TM) is operated in positions 3/5. The sender R2 switch controls final brush selection in position 10, final tens selection in position 12, and final units selection in position 14, the sender being satisfied in each case by ground pulses from the final "A", "T" and "U" commutator segments, respectively. The release of the (L) relay after the sender has been satisfied for each of these selections advances the final switch to positions 3, 5 and 8, respectively, position 7 being a passby position. When final brush selection is completed, the sender R2 switch advances from position 10 to position 11 but cannot advance to position 12 for final tens selection until the RC switch has advanced beyond terminal 4, that is, until the T register has been set, likewise when final tens selection has been completed the R2 switch advances from position 12 to position 13 but cannot advance to position 14 for final units selection until the RC switch has advanced beyond terminal

5, that is, until the U register has been set. The advance of the R2 switch from positions 11 and 13 is prevented, when the T and U registers respectively have not been set, by the operation of the (S) relay in positions 10/11 or 12/13 of the R2 switch.

Line Busy Test - Called Line Idle

The final selector now proceeds to test the called line to see whether it is busy or idle. Fig. 3 shows the busy test circuit and the busy and idle conditions on the sleeve terminals of individual lines and trunks to Private Branch Exchanges. Let it be assumed that the called line is one which connects directly to a subscriber's set and that the line is idle. In this case there is a 1100 ohm ground condition on the sleeve terminal of the selected line. When the final switch enters position $7\frac{3}{4}/8$, the (L) relay operates to ground through the make contact of the (TK) relay closing the circuit from the sleeve multiple brush to ground through the windings of the (TB) and (PBX) relays and advancing the switch to position 9. This operation can be followed on Fig. 4 which shows schematically a final selector circuit in its entirety. Neither the (TB) nor (PBX) relays operate and when the switch leaves position 8, the (L) relay releases thus advancing the switch to position 12, positions 10 and 11 being pass-by positions. If the (TK) relay is holding over the sleeve lead to ground in the incoming circuit when the final switch enters position 12, the final switch is advanced to position 13. With the (L) relay not operated in position 13, the switch is advanced to position 14 in which position the "T" and "R" leads from the incoming are connected through the T and R multiple brushes to the called line, and the switch remains in this position during talking and until the connection is released by the incoming. The other conditions which may be encountered by the final selector when testing the sleeve of the selected line will be considered later in this chapter.

Incoming Advance

When the final switch advanced beyond position $7\frac{1}{2}$, it disconnected ground from the ring side of the local trunk thus releasing the incoming (L) relay and thereby telling the incoming selector that final selections had been completed. (See Fig. 2). The release of the incoming (L) relay advances the

incoming switch to position 9 in which position the incoming connects battery through the winding of the (L) relay to the ring side of the incoming trunk, and with the fundamental circuit closed by the sender (R2 switch in position 16 as shown in Fig. 1) current flows through the (STP) and (OFL) relays in the opposite direction to that in which it flowed during district, office, incoming and final selections. Both the (STP) and (OFL) relays in the sender and the (L) relay in the incoming operate at this time. The (OFL) relay locks in position 16 and closes the circuit in which the incoming advance (IA) relay operates. The operation of the (IA) relay closes the circuit through the make contact of the (STP) relay in which the (O) counting relay operates. The operation of incoming (L) relay advances the incoming switch to position 11 and the fundamental circuit is not opened until the incoming switch has advanced beyond position 10. The opening of the fundamental circuit by the incoming switch releases the incoming (L) and sender (STP) relays thus causing the operation of the (BO) and (FO) counting relays. The operation of the (BO) relay opens the fundamental circuit in the sender and the operation of the (FO) relay closes a circuit in which the advance (AV) relay operates. The operation of the (FO) relay also advances the R2 switch to position 17. The release of the (OFL) relay when the switch advances from position 16, releases the (IA) relay thereby advancing the sender R2 switch to position 18.

The operation of (OFL) relay in position 16 tells the sender that all selections which it controls have been completed and the sender in turn tells the district selector so as to advance the district out of the selection beyond position in which its switch has been resting during office and final selections. To this end, the operation of the sender (AV) relay as shown in Fig. 5 opens the short circuit around the 21,000 ohm winding of the (SC) relay, thus increasing the resistance in this lead to such an extent that the district (SC) relay releases; but the sender (SC) relay holds operated. The release of the district (SC) relay, releases the district (L) relay thus causing the advance of the district switch out of the selection beyond position (position 10) to position 12. When the switch enters position 11 ground is connected to the SC lead instead of battery thru the windings of the (SC) and (D) relays, thus causing the release

of sender (SC) relay and thereby telling the sender that the district is ready to advance to the proper talking position as controlled by the sender. The release of the sender (SC) relay, releases the sender (SC1) relay, thus operating the sender (H) relay and releasing the sender (H1) relay. The H relay locks over the SC lead to ground on the district switch in positions 11/1. When the district switch advanced beyond position 11 $\frac{1}{2}$, the tip and ring sides of the calling line were disconnected from the "T" and "R" leads to the sender circuit, and were connected to battery and ground through the windings of the repeating coil and through the winding of the district supervisory (S) relay. The sender (L), (SR) and (SR1) relays are thus released and the (S) relay operates over the subscriber's loop and does not release until the subscriber replaces the receiver on the switchhook. The operation of the (S) relay causes the operation of the (SC) relay which locks to ground under control of the F1 contact of the disconnect (DISC) interrupter.

Talking Selection

With the sender (AV) relay operated and the (SC1) relay released, the fundamental circuit, as closed for talking selection, is traced from battery through the P winding of the district (L) relay over the "FT" lead through the windings of the (STP) and (OFL) relays to ground through a 1000 ohm resistance. The district (L) and sender (STP) relays operate. The district (L) relay, operated, locks through its own make contact to the "FT" lead and closes the district switch R magnet circuit. As the district switch advances, ground is connected to the "FT" lead by one of the district switch cams, in positions ~~12 $\frac{3}{8}$~~ -13 $\frac{3}{8}$ -14 $\frac{3}{8}$ -15 $\frac{1}{4}$ /18 thus holding the (L) relay operated but short circuiting and causing the release of the sender (STP) relay. Each operation and release of the stepping relay causes the operation of one set of counting relays. The first counting relay to be operated depends upon the setting of the translator, the circuit being controlled by the talking selection (TS) translator brush. When the sender is satisfied the (BO) and (FO) relays operate opening the fundamental circuit so as to release the district (L) relay and stop the district switch in the next position, in which the talking circuit is established for this particular call. The sender has completed its duties and returns to normal, but the

description of its return is postponed for the time being.

Trunk Closure - Ringing

With the district switch in the talking position it closes the trunk to the incoming selector thru the winding of the (CS) relay. (See Fig. 6). With the incoming selector in position 11 and assuming that the district switch on this particular call has been advanced to position 14, "Talking Charge", the trunk closure circuit is traced from battery through the S winding of the incoming (A) relay, through one winding of the repeating coil in the incoming, over the tip side of the incoming trunk, through the office selector (when used) through one winding of the repeating coil in the district, through the winding of the (CS) relay, winding of the repeating coil, over the ring thru the office selector (when used) to the incoming, through the winding of the repeating coil and P winding of the (A) relay to ground. The (A) relay operates in this circuit but the (CS) relay does not since it is polarized and the current is in the non-operating direction. The operation of the incoming (A) relay closes a circuit thru the winding of the incoming (L) relay which operates and locks in position 11 advancing the incoming switch to position 12. The (L) relay holds in position 12/14 under control of the incoming (A) and (R) relays. The incoming switch is advanced from position 12 to 14 by the operation of the (I) relay under control of the (IR) interrupter. With the incoming switch in position 14, ground is connected over the "T" lead through the final selector circuit to one side of the subscriber's line, and a lead from the ringing machine is connected through the winding of the ringing (R) relay, over the "R" lead, through the final selector circuit, to the other side of the subscriber's line as shown in Fig. 6. The called subscriber's bell rings and at the same time a circuit is closed thru a .02 MC condenser and winding of the (S) relay to the repeating coil whereby "audible ringing" is transmitted to the calling subscriber. When the receiver is removed from the switchhook at the called station, the (R) relay operates, releasing the (L) relay, thus opening the ringing circuit. The release of the (L) relay advances the incoming switch to position 16 in which position the talking connection from the calling subscriber is completed through to the called subscriber.

Talking

The district selector supplies talking battery to the calling subscriber and the incoming selector supplies talking battery to the called subscriber through windings of repeating coils in these two circuits. See Figure 8. The district and incoming circuits each contain a supervisory relay designated (S) which remains operated as long as the receiver is off the hook at the calling and called stations respectively. These supervisory relays are similar to those associated with the answering and calling cords at a manual A board. The transmission of voice currents is accomplished, in the same manner as that in use in a manual office, by the use of repeating coils and condensers.

The operation of the incoming (S) relay causes the operation of the incoming (I) relay whereby the battery and ground through the windings of the (A) relay are reversed with respect to the tip and ring sides of the trunk so as to cause the current through the district (CS) relay to flow in the opposite direction. The district (CS) relay now operates and the incoming (A) relay is held operated in this circuit. The operation of the (CS) relay indicates to the district that the called subscriber has answered and that if the calling line is a message rate line, the message register should be operated or if it is a coin line the coin should be collected when conversation is completed. Therefore, with the (CS) relay operated, the (LF) relay operates when the charge (CHG) interrupter closes its back contact. The (LF) relay locks under control of the (CS) relay and when the (CHG) interrupter closes its front contact, the (CH) relay operates and locks. With the (CH) relay operated when the calling subscriber replaces the receiver on the switchhook the message register on a message rate line is operated or the coin is collected on a coin line but where the (CH) relay is not operated at the time the connection is released the message register is not operated or the coin is returned. A separate circuit known as the Coin Control Circuit connects to the district at the proper time for returning or collecting the coin on a coin line.

Called Line Busy

Returning to the point where the final selector is testing the selected line, let it be assumed that the called line is not idle, but is busy, having

previously been selected by some other final selector on a terminating call, or having previously been selected by a line finder circuit on originating a call. The sleeve terminal is connected to the 48 volt battery through 220 ohms resistance, in addition to being connected to ground through the winding of the (CO) relay (See Fig. 4). Under this condition, the (TB) and (PBX) relays both operate and when the final switch enters position 9, the (L) relay holds to ground through the make contact of the (TB) relay and the operation of the (PBX) relay releases the (TK) relay. The release of the (TK) relay advances the switch to position 12, in which position the (TK) relay reoperates and locks over the sleeve lead to ground in the incoming selector circuit. The reoperation of the (TK) relay advances the switch to position 13, in which position the DOWN magnet is operated and the selector returns to normal. When the selector reaches normal, the switch is advanced to position 17 in a circuit through the "Y" commutator segment and brush. In position 17 a circuit is closed as shown in Fig. 8 from ground through a power driven interrupter in the "miscellaneous tone and interrupter" circuit which alternately operates and releases the final (L) relay. The alternate operation and release of the (L) relay alternately closes and opens a circuit from a tone lead in the "miscellaneous tone and interrupter" circuit through resistance B1, B2 and S (total 720 ohms) over the ring lead to battery through the winding of the incoming (S) relay. The tone is inductively transmitted to the calling subscriber thereby informing him that the called line is busy.

PBX Trunk Hunting

If the called line, which has been selected by the final selector under control of the sender, is the first trunk in a group of PBX trunks and is idle, the sleeve terminal is connected to ground through the 100 ohm winding of the (CO) relay (See Figs. 3 and 4). In this case, the operation is exactly the same as that described when the called line was an idle direct line to a subscriber's set. But if this first trunk in the PBX group was not idle, but was busy, the sleeve terminal would be connected to 48 volt battery through 220 ohms resistance in addition to being connected to ground through the winding of the (CO) relay. In this case, the (TB) relay operates, but the (PBX) relay does not

operate when the (L) relay closes the busy test circuit in position 8. The (L) relay holds to ground through the make contact of the (TB) relay and when the switch enters position 9, the (LS) magnet is energized in a circuit through the make contact of the (L) relay to ground through the make contact of the (TK) relay. The (TK) relay does not release since the (PBX) relay did not operate. The elevator moves upward and the sleeve brush makes contact successively with the sleeve terminals of the trunks in this P.B.X. group. The sleeve brush on a final selector is not a bridging brush but the (L) relay is held operated by the "C" commutator and by the make contact of the (TB) relay sufficiently to keep the elevator moving upward between terminals. When an idle terminal is reached, the (TB) relay releases but the circuit through the "C" commutator segment holds the (L) and (TK) relays operated until the elevator has been driven high enough to insure proper centering of the multiple brush on the terminals of the selected trunk. When the circuit through the "C" commutator segment is opened, the (L) relay releases, the UP magnet circuit is opened and the brush rod drops down against the pawl which has entered the corresponding slot in the rack. The release of the (L) relay advances the switch to position 12 and from this point the operation is no different from that described for a call to an idle direct line.

The sleeve terminal of the last trunk in the P.B.X. group is connected to the (CO) relay in the same manner as a direct line, and therefore, if all of the trunks in a P.B.X. group are busy both the (PBX) and (TB) relays operate when the sleeve brush makes contact with the sleeve terminal of this last trunk. When the circuit through the "C" commutator segment is opened, the (TK) relay releases opening the UP magnet circuit. The release of the (TK) relay also advances the switch to position 12 and from this point on the operation is the same as previously described for a call to a busy direct line.

Return of Selectors to Normal

When the calling subscriber replaces the receiver on the hook, the district (S) relay releases and when the F1 contact of the DISC. interrupter opens, the (SC) relay releases (See Fig. 9). The release of the (SC) relay operates the (D) relay through the F2 contact on the DISC. interrupter, advancing

the district switch to position 17. The (LF) relay operates in position 17 and locks through the "M" commutator segment advancing the switch to position 18. In position 18 the line finder and district DOWN magnets operate driving the line finder and district elevators down to normal. When the line finder elevator reaches normal, the "M" segment is opened and the (LF) relay releases, releasing the line finder DOWN magnet. When the district elevator reaches normal ground thru the district "Y" commutator brush and segment advances the line finder district switch to position 1 "Awaiting Link".

When the district switch advanced beyond position $15\frac{1}{2}$ the trunk closure was opened and the incoming (A) relay released. The release of incoming (A) relay released the incoming (L) relay thus advancing the incoming switch to position 18, in which position the DOWN magnet was energized and the elevator returned to normal. When the elevator reaches normal, ground through the "Y" commutator brush and segment advances the incoming switch to position 1.

When the district switch advances beyond position $16\frac{1}{2}$, busy ground was disconnected from the sleeve brush thus releasing the office (L) relay. The release of the office (L) relay advances the office switch to position 18, in which position the DOWN magnet is energized. When the elevator reaches normal, ground thru the "Y" commutator brush and segment advances the office switch to position 1.

When the incoming selector advances beyond position $16\frac{1}{2}$, the busy ground is removed from the sleeve multiple brush, releasing the (TK) relay in the final selector circuit and thus advancing the final selector switch to position 15. The (L) relay operates in position $14\frac{1}{2}$ and holds over the called subscriber's loop until the receiver is replaced upon the switchhook. With the (L) relay held operated, the switch is advanced through positions 15 and 16 by the operation of the (TK) relay under control of the (TO) interrupter within from 2 to 4 minutes after the final is released by the incoming. When the (L) relay releases due either to the advance of the switch from position 16 or on account of the receiver being replaced on the switchhook, the switch is advanced to position 18 by ground through the back contact of the (TK) relay. In position 18 the DOWN magnet is energized and when the elevator reaches normal, ground on the "Y"

commutator segment advances the final switch to position 1 (NORMAL).

Sender Returns to Normal

Having thus completed a call and returned the line finder-district, office, incoming and final selector circuits to normal, it is necessary to return to the point at which talking selection was completed and follow through the operation required to return the sender to normal and in advancing the link from the "cut-through" position into the "hunting district" position. As soon as the registers are no longer needed for controlling selections, they are reset to normal as shown in Fig. 10, which is self-explanatory. When the district selector advanced out of the selection beyond position the sender (SC) and (SC1) relays released and the (H) relay operated and locked to ground in the district selector circuit over the "SC" lead. With the (FO) relay operated on the completion of talking selection, a circuit was closed in which the (W01) relay operates, advancing the R1 switch to position 9. See Figure 10. When the R1 switch enters position 8, battery through the 270 ohms is connected in parallel with the winding of the (H) relay to the "SC" lead causing operation of link (T) relay. Operation of the (T) relay operates the link (C) relay, advancing the link switch to position 6. The (T) relay releases when the switch advances beyond position $5\frac{1}{2}$, and if the sender selector elevator is not standing on one of the last 20 (or 10) sets of terminals, the (C) relay releases and the link switch is advanced to position 7 which is the "Hunting District" position-- the same position in which we originally assumed the link to be at the time we originated a call. With the sender R1 switch in position 9, the sender R2 switch is advanced to position 1. With the R2 switch in position 1, the RC switch normal, and with relays (H), (H1) and (SR) released, the R1 switch is advanced to normal, releasing the (SC) relay. The class switch stays in the position in which it was used until it is advanced to some other position on a succeeding call. All equipment used on the call, whose operation has been followed, has now been restored to normal.

Time Alarms

When a call is originated and a "trip" circuit (A) (or (B)) relay operates, a timing circuit starts operation and, if the called line has not been

found and the (A) (or (B)) relay released within from 5 to 12 seconds, an aisle pilot lamp is lighted and an audible alarm is operated. An individual lamp also lights, indicating the particular trip circuit which has not been released within the measured time.

When the (GA) or (GB) relay in the "start" circuit fails to operate within an interval of from 2 to 5 seconds after ground has been placed on the STA (or STB) lead, an audible alarm is operated, and individual and aisle pilot lamps are lighted to assist the maintenance force in finding the particular circuit which is in trouble. At the same time as the alarm is operated a so-called "Throw-over Feature" becomes operative whereby all succeeding calls will be served by links and line finders in the sub-group which is not affected by the trouble which caused the throw-over.

When a link circuit becomes stuck in the "Awaiting District", "Hunting Sender", "Awaiting Sender", "Return from last 10 (or 20) SS Terminals", an alarm is operated within from 20 to 30 seconds after the sequence switch enters the position in which it is stuck.

When a calling subscriber fails to replace the receiver on the hook within from 2 to 3 minutes after the called subscriber replaces the receiver on the hook, or within from 2 to 3 minutes after the district enters the overflow position and transmits overflow signal to the calling subscriber, an alarm is operated.

Sender Time Measure Switch

Failure of any selector to perform its function under control of a sender as well as failure of the sender itself results in what is known as a "Stuck Sender". The "Time Measure" switch (M) is used with a power driven interrupter designated "TMA" to measure time intervals within which the various parts of the sender's operation should be completed. See Figure 11. As soon as a sender is seized and made busy, the (TMS) relay operates and locks to "off-normal" ground. The time measure advance (TMA) relay operates advancing the (M) switch from normal. Its further advance is under control of the (TMA) interrupter and the setting of the RC switch. Thus, an interval of from 30 to 60 seconds is allowed within which dialing must be started. If the RC switch

has not been advanced from normal during this interval, a circuit is closed through terminal 4 on the M6 arc operating the stuck sender-release (SSR) relay. The operation of the (SSR) relay at this time causes the sender to function in such a way that the call is completed and the line is connected to a trunk terminating at a permanent signal operator's position.

If dialing is started and the RC switch advanced from normal within the time allowed, the time measure switch begins to measure a new interval of from 30 to 60 seconds within which dialing must be completed. If dialing is not completed within this interval a circuit is closed through terminal 7 on M6 arc causing a partial dial signal to be displayed at a sender monitoring position. The monitoring operator inserts a talking cord in a jack associated with this lamp and attempts to have the subscriber complete dialing or replace the receiver on the hook; but if unsuccessful the insertion of the talking cord plug in a make-busy jack (an operation called priming) causes the line to be connected to a permanent signal trunk in cases where translation has not previously been completed, and causes the sender to return to normal if translation has been previously completed.

After dialing is completed and if the line is not a coin line the time measure switch allows an interval of from 30 to 60 seconds on calls to the other panel type offices within which the sender should complete its operations and return to normal. If the sender has not completed its functions within this time the time measure switch closes a circuit which flashes a lamp at the sender monitoring position and the sender may be released by priming as previously described.

When the calling line is a coin line and after dialing has been completed within the allowed time, the time measure switch closes and controls circuits in which tests are made to determine whether the coin has properly been deposited except on calls for which no charge is made, such as a call to information operator. Should the test indicate that there is no coin deposited or that there is a false coin ground on the line, the time measure switch closes a circuit which causes a lamp to light at a monitoring operator's position. Should the coin subsequently be deposited the call will proceed, otherwise

the equipment will be held until released by priming. After a test has shown that the coin has been properly deposited the M switch measures the interval within which the sender should complete its operation, as previously described.

Coin Control

When the calling line is a coin line and a coin has been deposited it should either be collected or returned after the receiver is replaced upon the switchhook. When the district (S) relay releases the district is selected by an idle "Coin Control" circuit. This circuit collects the coin by connecting +110 volts to the line if the charge (CH) relay in the district is operated and returns the coin by connecting -110 volts to the line if the (CH) relay is not operated. On the earlier panel installations the sender was reselected by the district under such conditions as caused the sender to limit its operation to the return or collection of the coin as the case required. It is more economical, however, to place this control equipment in an auxiliary circuit which connects itself to the district at the time it is needed.

Various Ringing Conditions

The arrangement shown in Fig. 6 for closing the ringing circuit is one which would be used for either individual or 2-party ringing. Fig. 7 shows the ringing circuit not only for individual and 2-party service but also for 4-party selective and 4-party semi-selective service. No further explanation is required for ringing where the service is individual or 2-party, except that usually immediate ringing is furnished in positions 12 and 13 during the time the switch is being advanced under control of the (IR) interrupter. Immediate ringing is continuous and not under control of the ringing machine so as to signal the subscriber as soon as trunk closure has been received by the incoming, even though the ringing machine should be on a silent part of the cycle.

Where 4-party selective ringing is used two of the stations are signalled over the tip side of the line to ground and the other two are signalled over the ring side to ground, this being accomplished by proper cross-connection at the M.D.F. Superimposed ringing current is used to distinguish between the two stations which are signalled over the tip side of the line and between the two stations which are signalled over the ring side of the line. One station on

Course A-132
Chapter XIV

each side is signalled with $\pm -$ and the other station on the same side is signalled with $\pm +$ ringing current. The four line numbers are assigned in such a manner that a call to either of the two which are signalled by $\pm -$ current will be completed over a trunk in groups 0 or 2 of any bank on the incoming frame, and a call to either of the two stations which are signalled by $\pm +$ current will be completed over a trunk in groups 1 or 3 of any bank. When a trunk has been selected by the incoming in either of groups 0 or 2, the incoming (P) relay remains non-operated, but when a trunk has been selected in either of groups 1 or 3, a circuit is closed in position 11/14 through the (P) commutator brush and segment operating the (P) relay. The polarity of ringing current connected to the line depends then on whether the (P) relay is operated or non-operated and this in turn depends upon the group in which the incoming has selected a trunk to a final selector.

Where 4-party semi-selective ringing is used, two stations are signalled over the tip side of the line and the other two are signalled over the ring side of the line. The (P) commutator is used to distinguish between the two stations which are signalled over the same side of the line, one of them being signalled by a one ring code and the other by a 2 ring code, both bells ringing at the same time. It is necessary that when ringing starts, both rings of a 2 ring code will always be given. To this end, the closing of the ringing circuit is under control of a pick-up (PU) drum on the ringing machine. When the incoming (A) relay has operated from trunk closure in the district, the (L) relay operates, advancing the switch to position 12. If the called line number is such that the incoming has selected a trunk in either of the groups 0 or 2, the (P) commutator circuit is not closed and the (L) relay releases when the switch advances from position 11. The incoming pick-up (PU) relay which closes the ringing circuit, operates immediately in position 12 to ground through the back contact of the (L) relay. Operation of the (PU) relay advances the switch to position 13 in which position the "R1" ringing lead is connected through the winding of the (R) relay, make contact of the (PU) relay and through the final selector to one side of the called line. If the called line number is such that the incoming has selected a trunk in either of groups 1 or 3 the (L) relay does not release when the switch advances from position 11 but holds to ground through

the (P) commutator segment and brush. In this case the operation of the (PU) relay is under control of the pick-up interrupter, and it is therefore operated at such a time as will cause the ringing circuit to be closed during the silent period preceding the first ring of the two-ring code. The operation of the (PU) relay advances the switch to position 13 and since the (L) relay is holding through the (P) commutator segment and brush, the switch does not stop in position 13 but advances to position 14. The (L) relay releases when the switch leaves position 13 and the switch is stopped in position 14. When the (R2) drum of the ringing machine completes the silent part of the cycle, ringing is started. The removal of the receiver from the switchhook at the called station operates the (R) relay in either of positions 13 or 14 causing the release of the (PU) relay, thus opening the ringing circuit and advancing the incoming switch to the talking position.

Overflow - Tell-Tale

When the district selector fails to find an idle trunk in the selected group, it stops on the overflow terminals of that group and the district switch advances to the "Selection Beyond" position as previously described. Ground through the "Z" commutator brush and segment operates the district (CH) relay thereby connecting "reversed battery" to the fundamental circuit. The sender (OFL) relay is operated and the sender realizes that the district selector "went to overflow". After dialing has been completed, the sender advances the district from the "selection beyond" position and controls talking selection as on a regular call except that the (3) counting relay is the first to be operated and the district switch is therefore advanced to position 17. In this position an "All Paths Busy Tone" is transmitted to the calling subscriber. See Fig. 8. The sender returns to normal as soon as talking selection is completed. When the calling subscriber replaces the receiver on the switchhook, the district supervisory (S) relay releases and the line finder district circuit returns to normal, as on a regular call.

Should the district selector "go to tell-tale", that is, travel to the top of the bank during the time the UP magnet is energized either for group or brush selection, or for trunk hunting, ground through the "X" commutator

brush and segment advances the district switch to position 7, in which position operation of the (L) relay advances the switch to position 8. Ground through the "X" commutator brush and segment then advances the switch to position 17. The "T" and "R" leads to the sender are thus immediately opened and ground is connected to the "SC" lead. The sender under this condition does not wait for dialing to be completed but returns to normal immediately; the district remains in position 17 and transmits overflow tone to the calling subscriber in the same manner as when it went to overflow.

If the line finder travels to the top of the bank without finding the calling line the elevator stops on the forty-first terminal (which is called an overflow terminal) if the multiple brush has been tripped for although there is no line connected to this set of terminals, the "trip" circuit connected battery to the (H) terminal the same as if it were a subscriber's line. When this set of terminals is connected through the line finder and link circuits to an idle sender, the sender (L) relay fails to operate and the sender immediately causes the district to return to normal and restores itself to the idle condition. If the line finder multiple brush were not tripped, the elevator travels past the 41st terminal until the "N" commutator brush has broken contact with the "N" segment. The (LF) relay then releases and the circuits are returned to normal as on "overflow" except that the trip circuit is not satisfied as it is when a calling line is found and has to "time itself out" of the busy condition, before it can be used on another call.

When an office selector "goes to overflow", ground through the "Z" commutator brush and segment advances the office selector to an "overflow" position in which "reversed battery" is connected to the fundamental circuit, (the district being in the selection beyond position), causing operation of the sender (OFL) relay. The sender and district circuits then function in a similar manner to that described for district overflow. When the district switch advances beyond position 16 $\frac{1}{2}$ ground is removed from the sleeve brush thus releasing the office (L) relay, and the office selector returns to normal as on a regular call. In some of the earlier installations, the office selectors were not arranged to connect reversed battery to the fundamental circuit on "tell tale"

condition and the equipment was stuck until released by a trouble operator or by the maintenance force. Office selectors are now arranged so that when they travel to "tell-tale" the operation is the same as that which occurs on "overflow" condition, except that it is the "X" commutator which causes the switch to advance to the "overflow or reversed battery" position.

When an incoming selector "goes to overflow", the incoming switch is immediately advanced to the "reversed battery" position, since there is no final selector connected to these terminals and therefore no ground to hold the incoming (L) relay operated. The sender (OFL) relay is operated and the sender causes the district to advance to the overflow position. In so doing, the district gives a temporary trunk closure which advances the incoming selector out of the "awaiting trunk closure" position. When the closure is removed by the district the incoming selector is returned to normal as on a regular call. If the incoming "goes to tell-tale" the operation is similar to that just described for "overflow", except that ground thru the "X" commutator brush and segment causes the advance of the switch to the "reversed battery" position, and also causes its return to normal as soon as the switch enters the trunk closure position.

When a final selector "goes to tell-tale" ground thru the "X" commutator brush and segment advances the final switch through the "busy test" position and the switch is then advanced, as on a regular call, to the "talking" position. The incoming proceeds to give "reversed battery" to the sender just as on a call when final selections were actually completed, but the sender, knowing that they have not been completed, accepts the operation of the (OFL) relay as a tell-tale signal and causes the district to advance to the overflow position and give the overflow signal to the calling subscriber. The final selector is returned to normal when released by the incoming as on a regular call.

Abandoned Calls

When a call is abandoned, the sender (L), (SR) and (SR1) relays release, causing the operation of a "wipe-out" (WO) relay. If district group selection has not been completed when the (WO) relay operates, the sender and district are returned to normal immediately. If district group selection has

been completed, office test and selections are also completed (when an office selector is used) and a trunk to an incoming selector is selected. The sender then causes the incoming to travel to tell-tale during brush selection; or if the call is abandoned after incoming brush selection has been completed, the sender causes the incoming or final (as the case may be) to travel to tell-tale on the next selection after the operation of the (WO) relay. With either the incoming or final at "tell-tale", return to normal is completed as described for tell-tale condition except that the district does not have to wait for the calling subscriber to replace the receiver on the hook. When a call is abandoned after the sender has completed its operation and during the time the called subscriber is being signalled, the district opens the trunk closure to the incoming. The incoming opens the ringing circuit, and return to normal of all the selectors involved is completed as on a regular call.

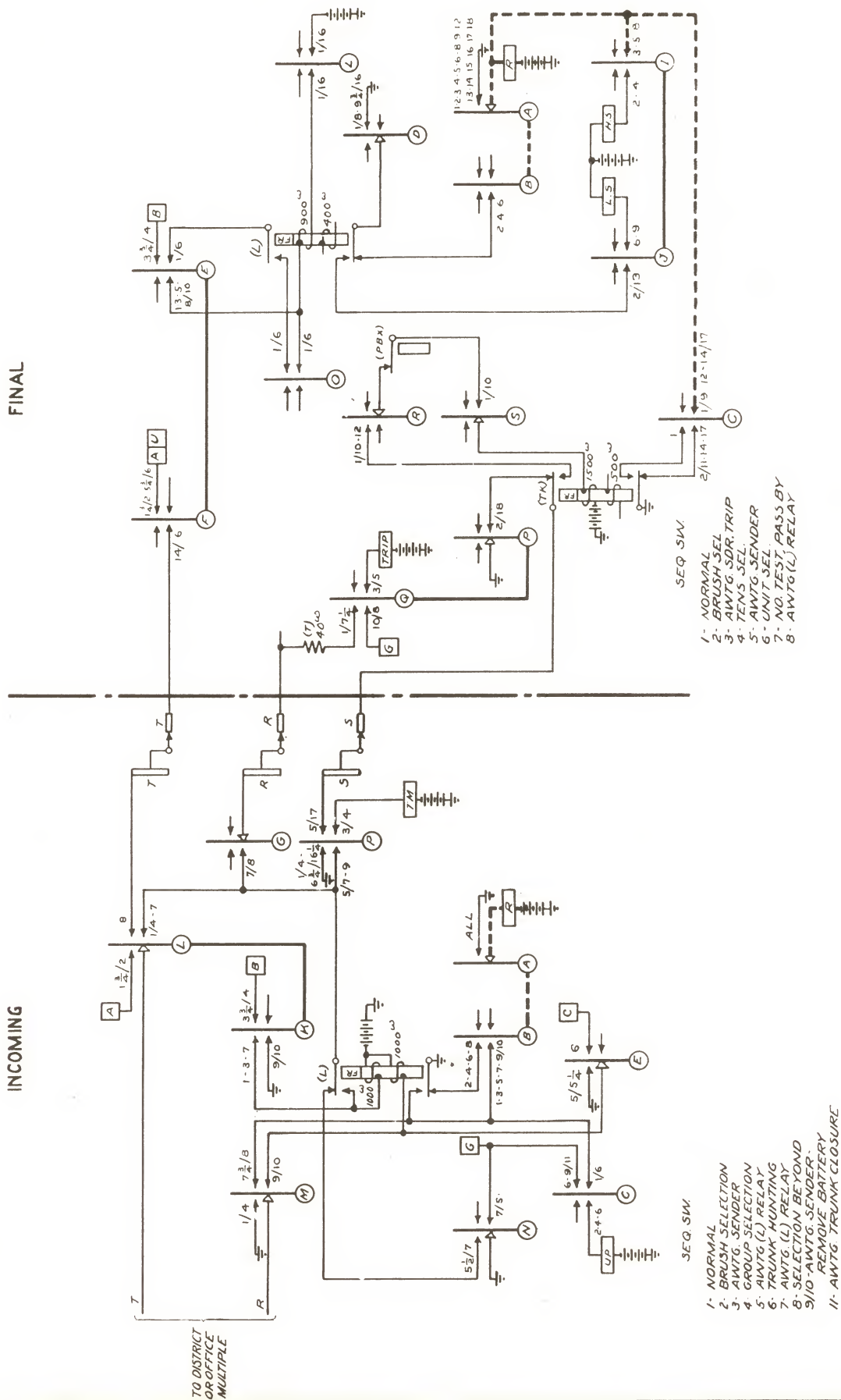

- SEQ. SW.
- 1- NORMAL
 - 2- BRUSH SEL
 - 3- AWTRG SDR. TRIP
 - 4- TENS SEL
 - 5- AWTRG SEL
 - 6- UNIT SEL
 - 7- NO. TEST, PASS BY
 - 8- AWTRG(L) RELAY

- SEQ. SW.
- 1- NORMAL
 - 2- BRUSH SELECTION
 - 3- AWTRG SENDER
 - 4- GROUP SELECTION
 - 5- AWTRG(L) RELAY
 - 6- TRUNK HUNTING
 - 7- AWTRG(L) RELAY
 - 8- SELECTION BEYOND
 - 9- AWTRG SENDER
 - 10- REMOVE BATTERY
 - 11- AWTRG TRUNK CLOSURE

INCOMING AND FINAL SELECTIONS
FIG. 2

DIRECT LINE OR LAST TRUNK OF P.B.X. GROUP

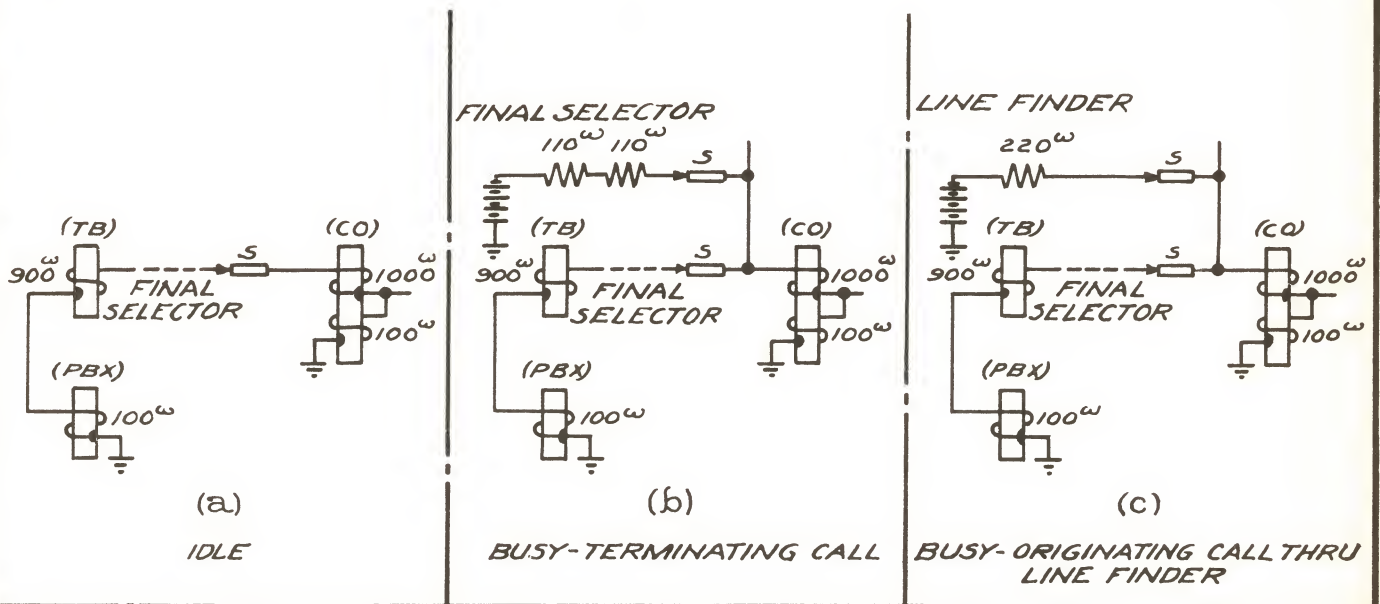

P.B.X. TRUNKS OTHER THAN LAST TRUNK OF A GROUP

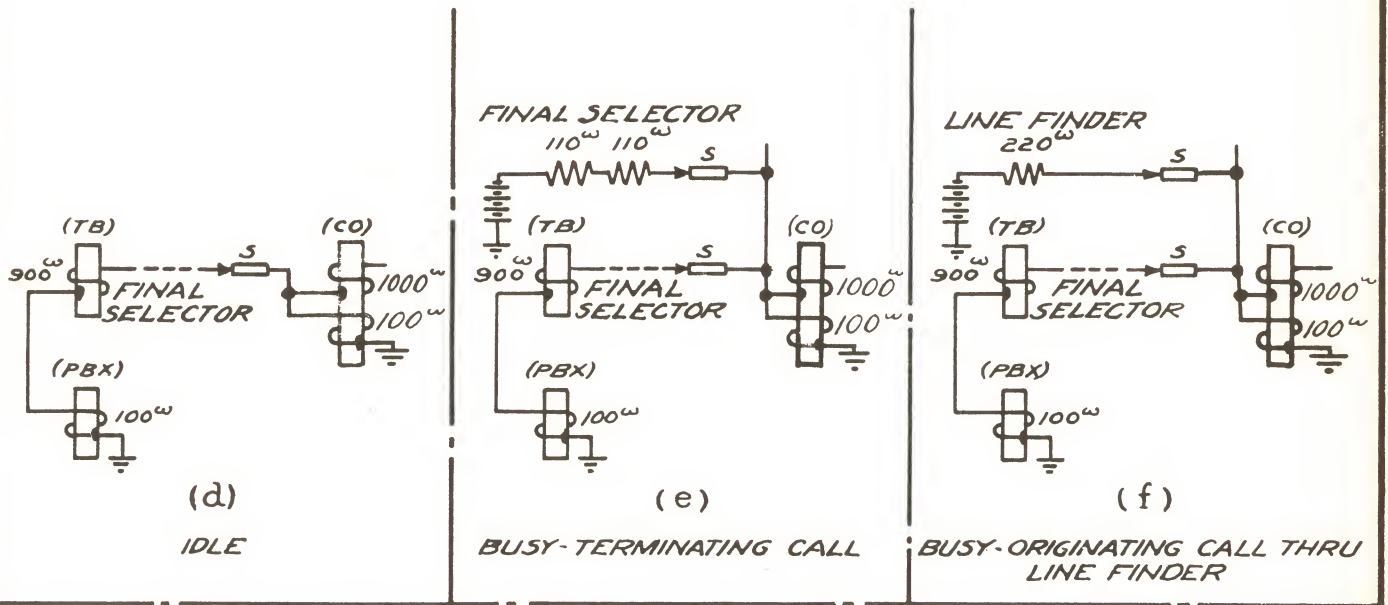

BUSY TEST CIRCUIT AND SLEEVE CONDITIONS
LINE FINDER OFFICE
FIG. 3

DISTRICT

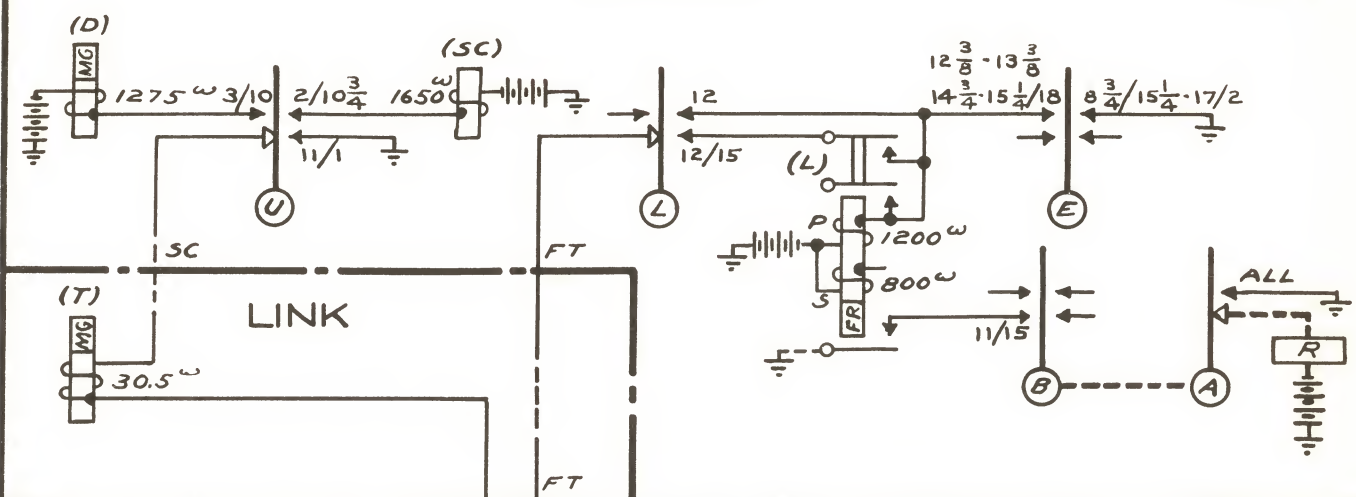

SENDER

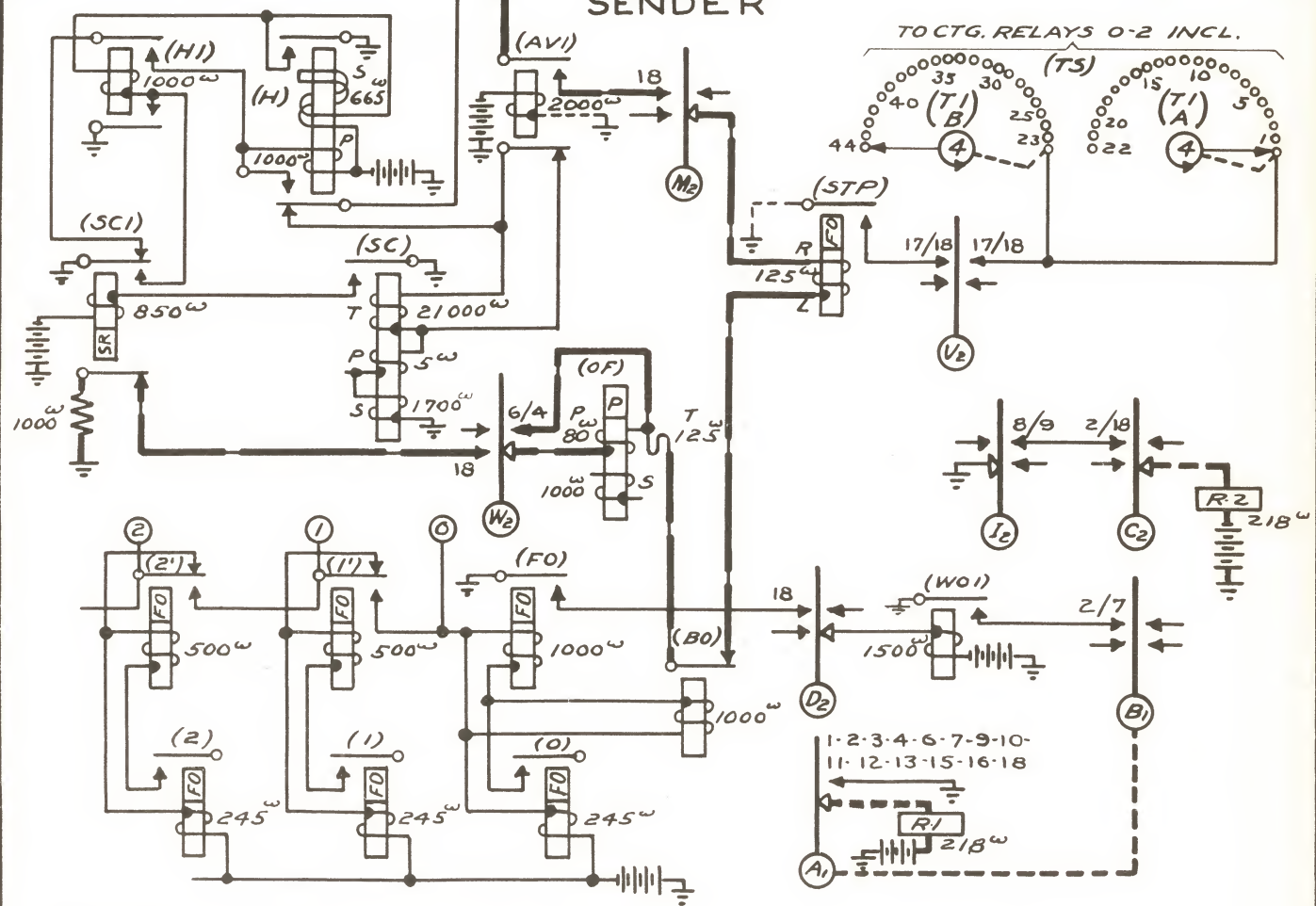

SEQ. SW. (R1)
 7-16 SEL. BEYOND OFF.
 8-17 PASS BY
 9-18 AWTG. RESTORE

SEQ. SW. (R2)
 18 - TALKING
 1 - NORMAL

TALKING SELECTION
 FIG. 5

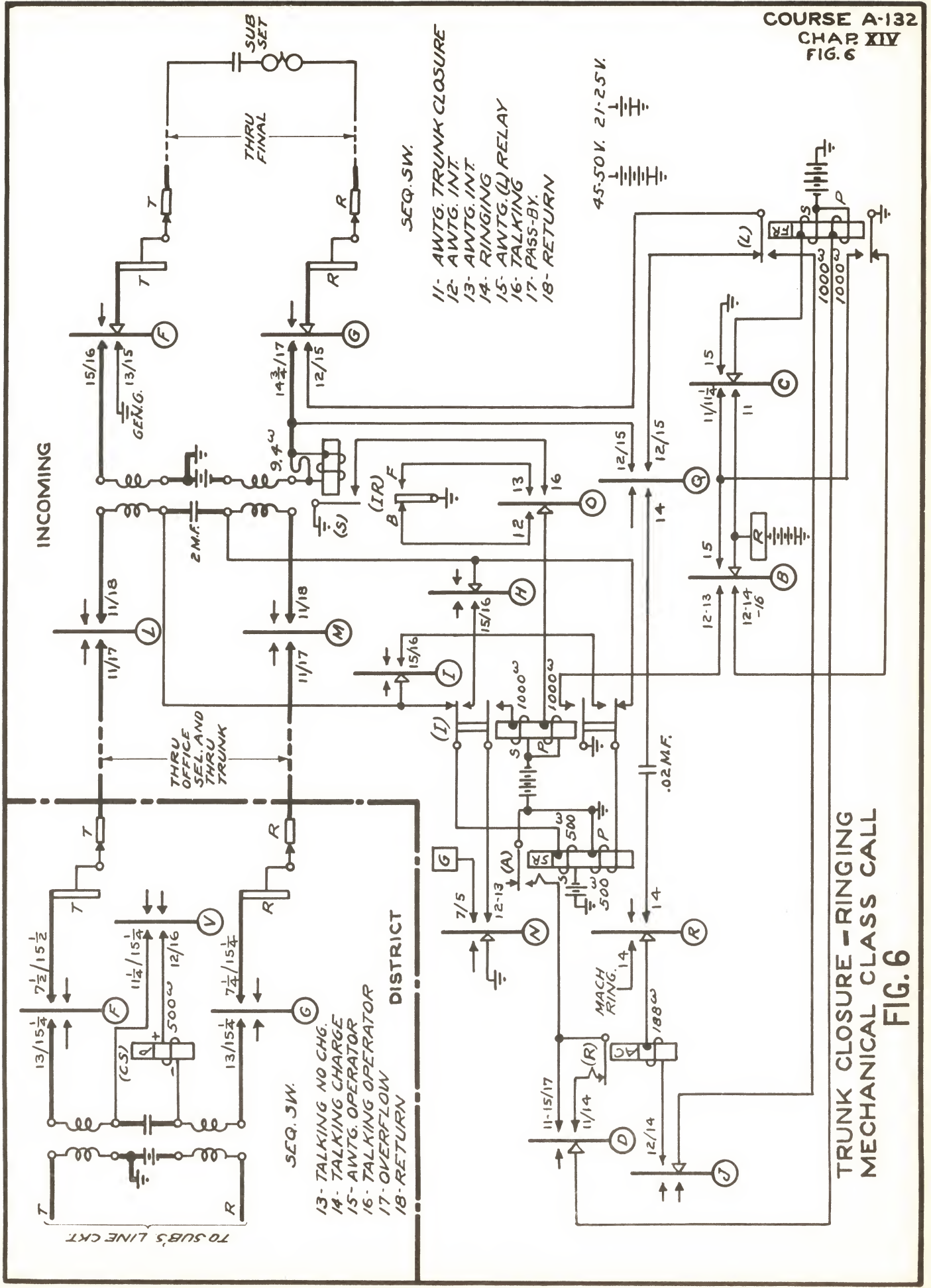

SEQ. SW.

- 11- AWTG. TRUNK CLOSURE
- 12- AWTG. INT.
- 13- AWTG. INT.
- 14- RINGING
- 15- AWTG. (L) RELAY
- 16- TALKING
- 17- PASS-BY
- 18- RETURN

45-50V. 21-25V.

INCOMING

DISTRICT

TO SUB'S LINE CKT.

SEQ. SW.

- 13- TALKING NO CHG.
- 14- TALKING CHARGE
- 15- AWTG. OPERATOR
- 16- TALKING OPERATOR
- 17- OVERFLOW
- 18- RETURN

TRUNK CLOSURE-RINGING
 MECHANICAL CLASS CALL
 FIG. 6

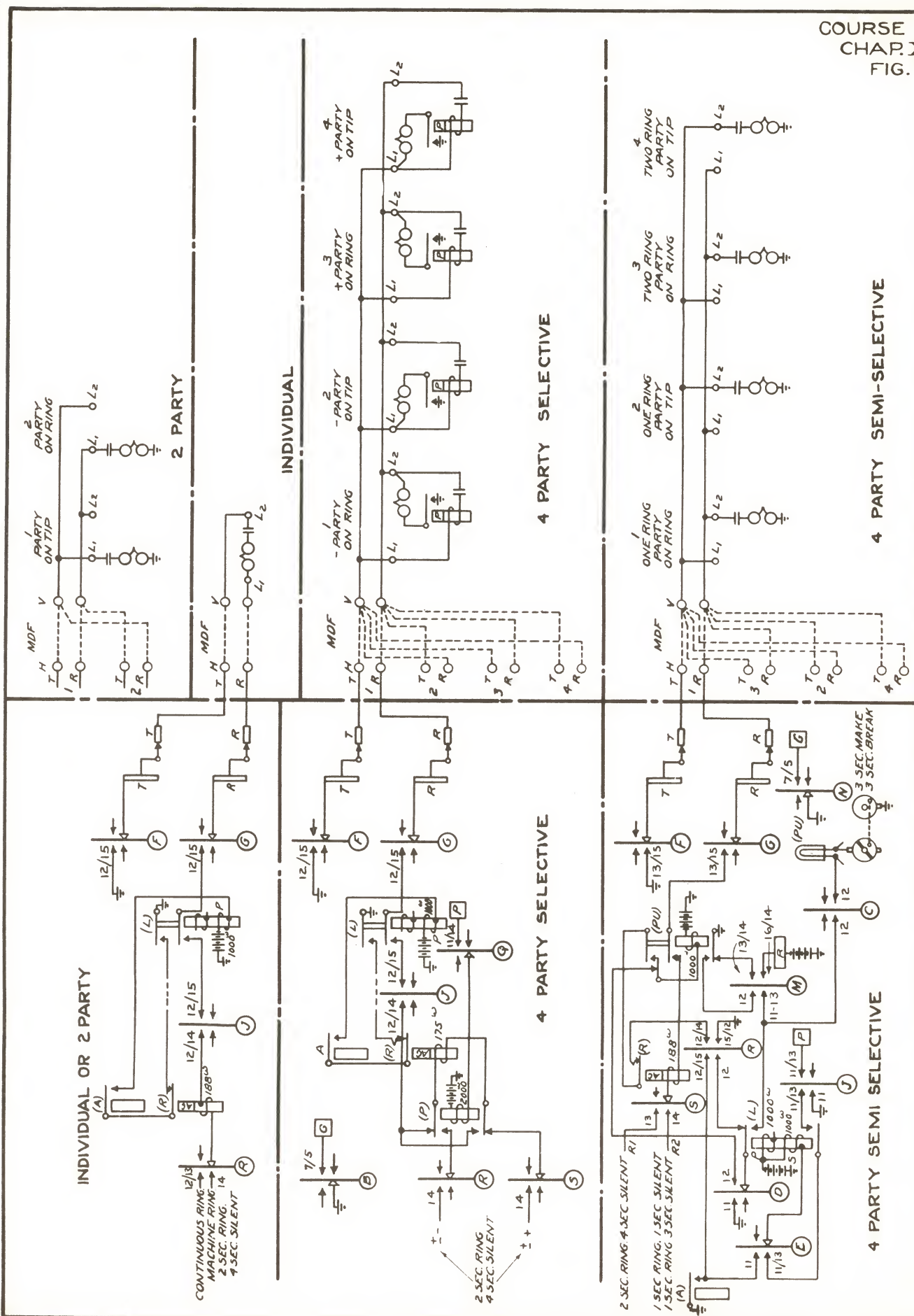

INDIVIDUAL, 2 PARTY, 4 PARTY SELECTIVE, AND 4 PARTY SEMI-SELECTIVE RINGING

FIG. 7

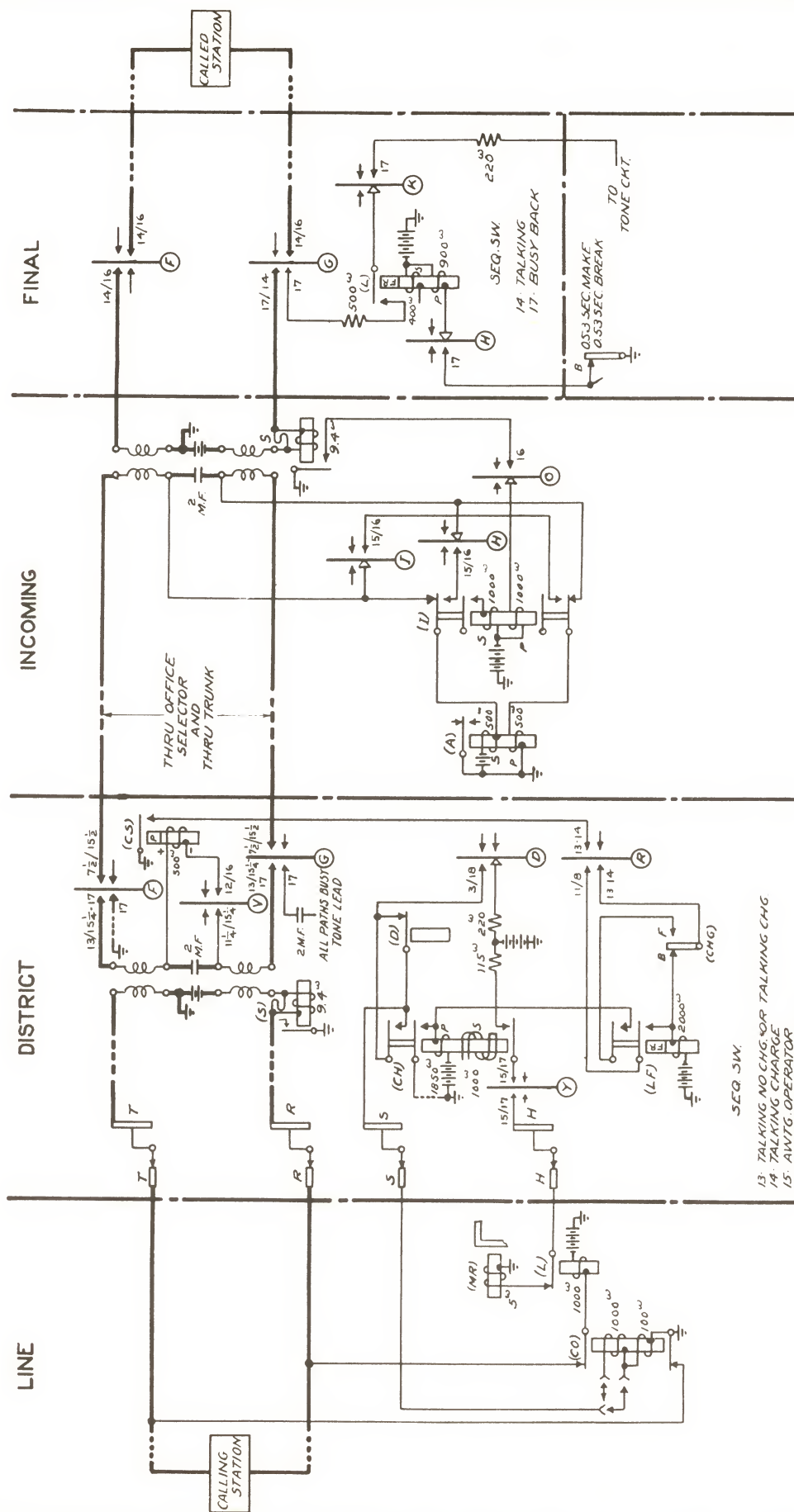

SEQ. SW.
 13. TALKING NO CHG. OR TALKING CHG.
 14. TALKING CHARGE
 15. ANVTG. OPERATOR
 16. TALKING OPERATOR
 17. OVERFLOW

TALKING - BUSY REPORT
 FIG. 8

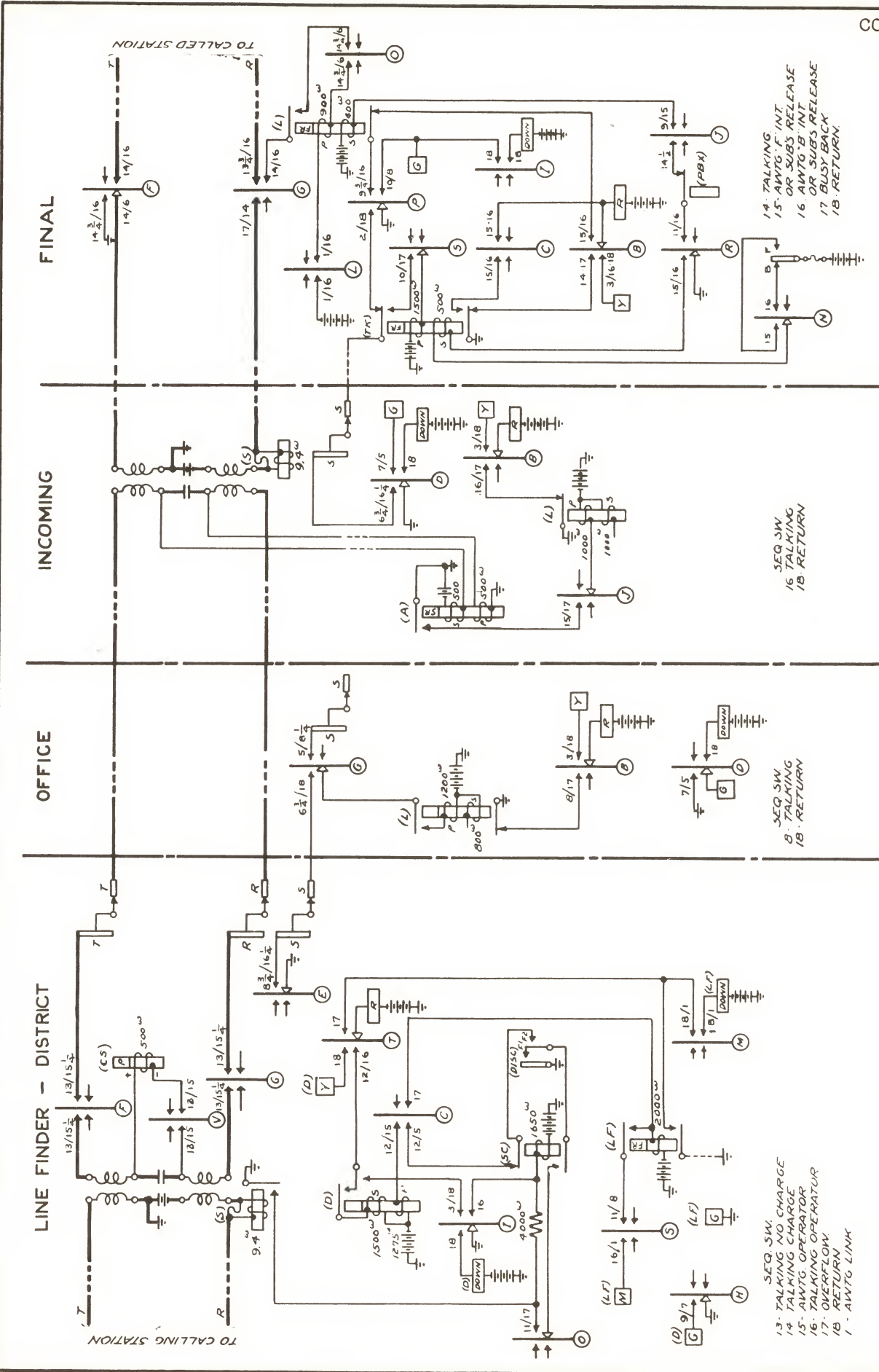

14. TALKING
 15. AWGTG 'B' INT
 OR SUBS RELEASE
 16. AWGTG 'B' INT
 OR SUBS RELEASE
 17. BUSY BACK
 18. RETURN

SEQ SW
 16 TALKING
 18 RETURN

SEQ SW
 8 TALKING
 18 RETURN

SEQ SW
 13. TALKING NO CHARGE
 14. TALKING CHARGE
 15. AWGTG OPERATOR
 16. TALKING OPERATOR
 17. OVERFLOW
 18. RETURN
 1. AWGTG LINK

RETURN SELECTORS TO NORMAL
FIG. 9

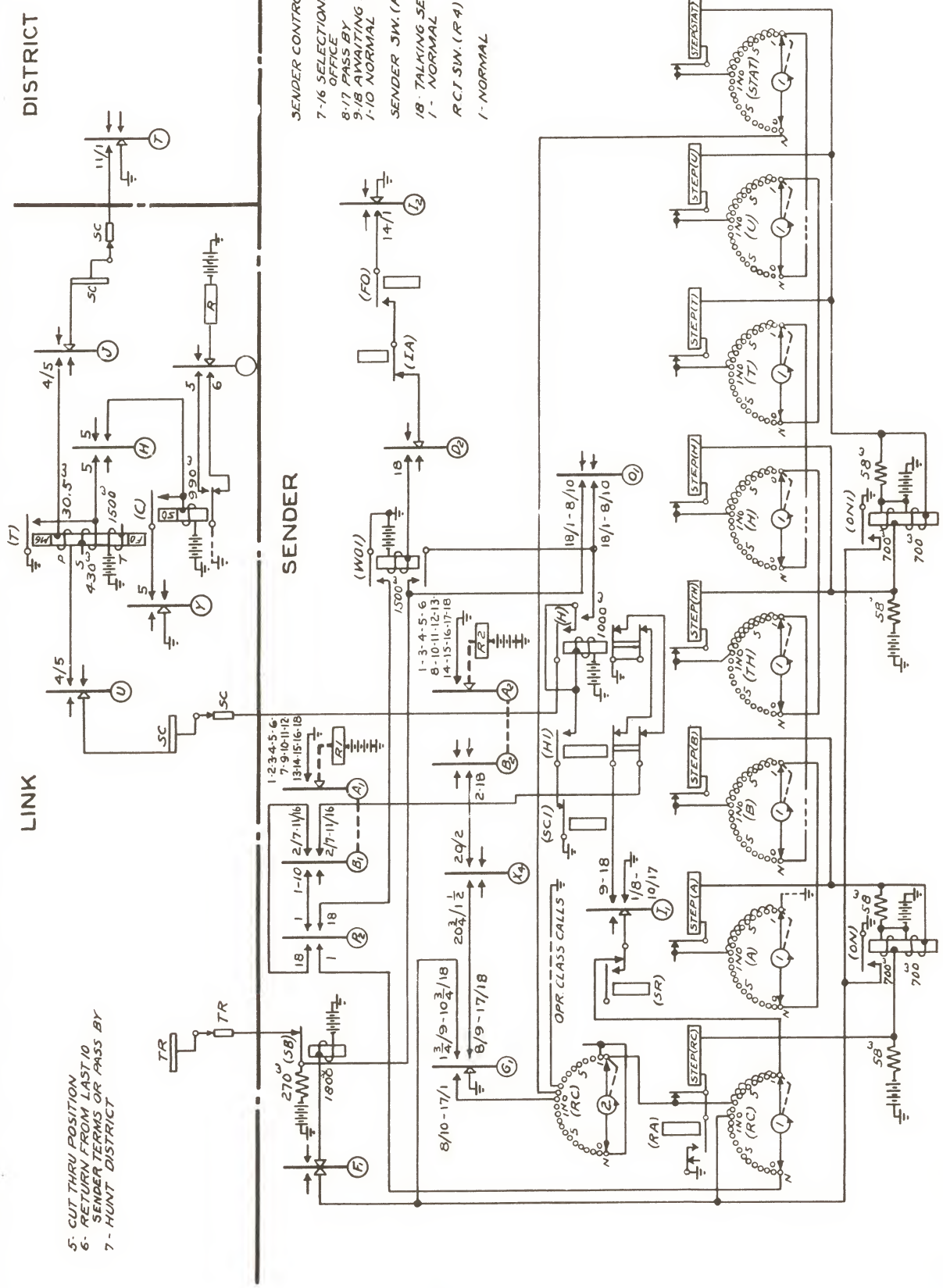

5 - CUT THRU POSITION
 6 - RETURN FROM LAST 10
 SENDER TERMS OR PASS BY
 7 - HUNT DISTRICT

SENDER CONTROL SW (R1)
 7-16 SELECTIONS BEYOND
 OFFICE
 8-17 PASS BY
 9-18 AWAITING RESTORE
 1-10 NORMAL
 SENDER SW. (R2)
 18 - TALKING SELECTION
 1 - NORMAL
 RCT SW. (R4)
 1 - NORMAL

SENDER TO NORMAL-LINK ADVANCE
 FIG.10

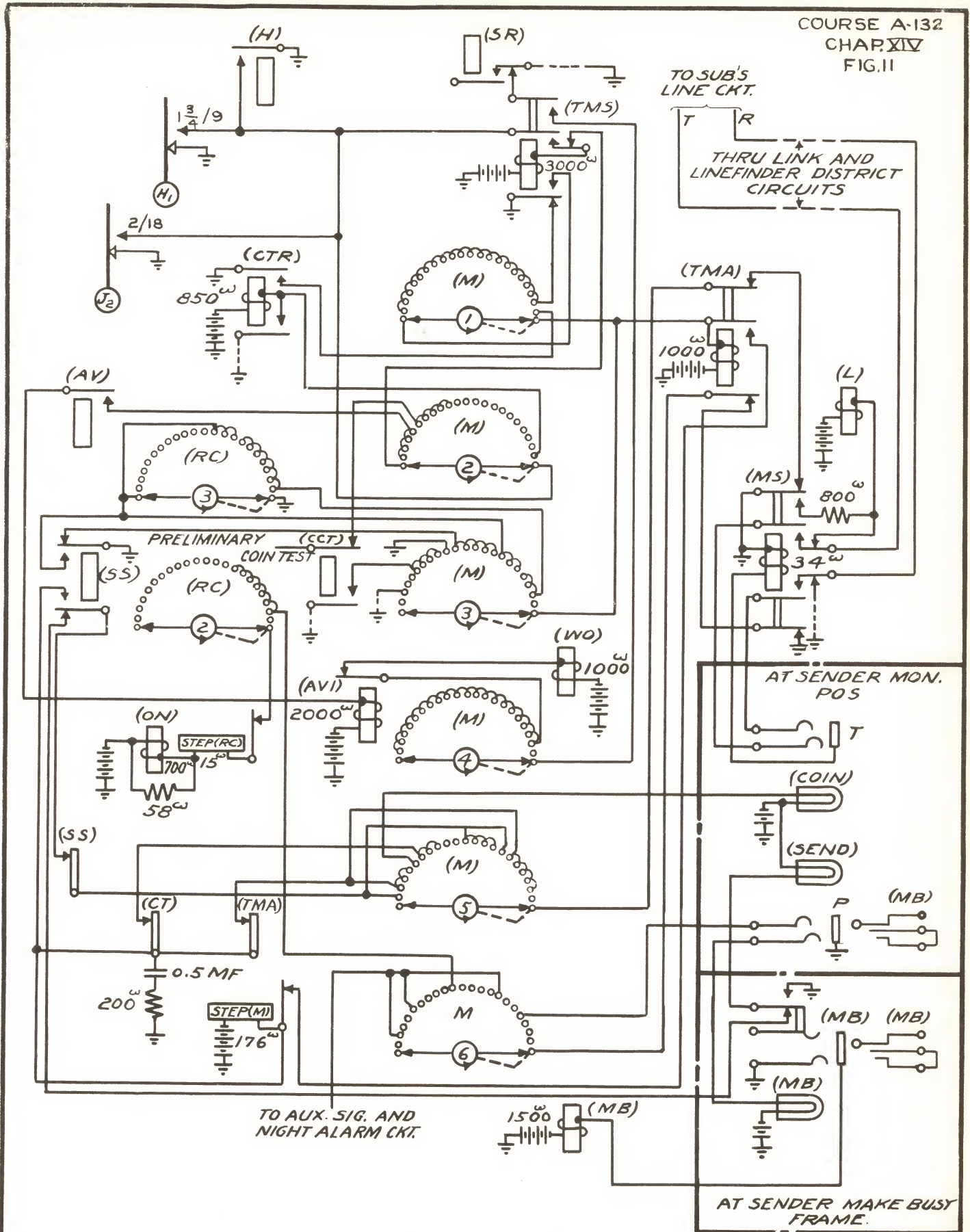

TIME MEASURE CIRCUIT
 FIG. II

CHAPTER XV

RCI EQUIPMENT AND OPERATION

Calls from subscribers in Panel offices to subscribers in manual offices may be completed over trunks direct to and terminating at, positions of the "B" switchboard which are equipped with relay call indicator, "RCI", equipment as shown in sketch A of Figure 1. On such a call the registers are set and translation completed by the sender in the same manner as on a mechanical class call. The CLASS switch (R3) is set in an "RCI DIRECT" class position and the sender causes the district and office selectors to select an idle trunk which terminates at a position of the "B" board in the manual office. An "assignment lamp" associated with this trunk lights telling the operator that the trunk has been selected. The operator depresses a "display" key associated with the lighted lamp, thereby causing the sender circuit in the panel office to transmit a code of "RCI" pulses, over the trunk, to the position "RCI Control" circuit. The RCI control circuit causes the called number to be displayed on a "call indicator" mounted in the keyshelf of the position. The manual operator inserts the plug of the trunk in a multiple jack of the called line and ringing is automatically controlled. In case the called line tests busy the operator inserts the plug in a "busy back" jack and busy tone is transmitted to the calling subscriber.

Sketch "A" in Figure 1 shows schematically the equipment involved in completing a direct RCI call; Figure 2 shows a No. 1-B switchboard position with RCI equipment, and Figure 3 shows the keyboard equipment of such a position.

The equipment at each RCI position includes a maximum of 48 plug ended trunks incoming from the panel office or offices with each of which is associated an assignment lamp, a disconnect lamp and one or two non-locking display keys. Number plates and designation strips are provided for numbering the trunk circuits. The RCI position control circuit consists of a number of relays mounted in the rear of the board directly behind the position with which they are associated. That combination of relays is operated on each incoming call, by the pulses from the sender in the panel office, as will cause the

called number to be displayed on the "call indicator". The call indicator consists of a set of lamps located under a ground glass plate arranged in 6 groups. Each lamp is so shielded that when lighted it will display a number or letter on the ground glass plate above it without allowing any light to illuminate neighboring characters. The first group at the left consists of two lamps marked 0 to 1 used for indicating the "ten thousands" digit and on calls where the number is below ten thousand, the 0 lamp lights when there is no party designation. The next 4 groups consists of 10 lamps each, numbered from 0 to 9 for displaying the "thousands", "hundreds", "tens" and "units" digits, respectively. The group on the right consists of 4 lamps numbered J, M, R and W which are used for displaying the party designation. When one of the ten thousands digit is displayed no party designation is displayed and vice versa.

As many positions at the "B" board in a manual office are equipped with RCI equipment as are needed to handle the traffic incoming directly from panel type offices. In order to provide teamwork between operators at adjacent positions a number of trunks are provided with two display keys. Figure 3 shows all trunks so equipped. The front key is the "home" or regular display key and its operation causes the called number to be displayed on the regular or home position indicator. The rear key is known as the "teamwork" display key and its operation by an adjacent operator causes the assignment lamp to flicker indicating to the operator at the home position that the call is being handled by the adjacent operator. Depressing the teamwork display key also transfers the "busy test" from the home operators telephone set to the adjacent operators telephone set.

Where the traffic to each of a number of manual offices is not sufficient to justify the installation of direct trunks and direct call indicator equipment in each of these manual offices, tandem RCI equipment is installed at "B" positions in one of the manual offices (or at some other office centrally located with respect to these offices). See sketch B Figure 1. Manual tandem operators receive all the calls for these offices over the tandem RCI trunks and complete these calls on a "call wire" or "straightforward" trunking basis to that one of this group of manual offices in which the called

line terminates. In this case the originating sender transmits current pulses not only for the called number but also for the office code. The tandem call indicator is therefore equipped with an additional set of lamps arranged in 3 groups of 10 lamps each on which a numerical code is displayed which corresponds to the office code which was dialed by the originating subscriber. The key board equipment includes a set of call circuit keys, where the calls are completed on a call circuit basis. These keys are arranged 12 in a strip and the office code numbers are engraved on the buttons. The office code abbreviation corresponding to the office code numbers are shown on a designation strip to the right of each row of buttons. The maximum of 144 call circuits can be installed. Only 40 trunks incoming from panel offices are terminated on each tandem RCI position. It will be evident that in general the operation of the incoming end of the tandem RCI position is similar to the operation of a direct RCI position.

Every direct or tandem RCI position is provided with a two-way locking key whose operation transfers the busy test circuit to the operator's telephone circuit of the adjacent position, so that during hours of light load one operator may complete connections at several positions without transferring her telephone set from position to position.

An emergency call indicator equipment is provided consisting of a set of lamps and a multiple contact plug which can be plugged into a jack mounted on the lock rail at the right end of each call indicator position. The relays associated with the emergency indicator are mounted in the terminal room and cabled to this jack at each of a group of positions. The trunks are switched from the regular to the emergency equipment by the operation of a locking key mounted above the subscriber's multiple. In case of failure of the regular call indicator apparatus the supervisor plugs in the emergency lamp set and operates the emergency key, thereby maintaining service.

When it is desired to discontinue the use of a position either during hours of light traffic or due to trouble that cannot be corrected by use of the emergency equipment, all trunks to this position must be made to test busy at the panel office. To do this it is necessary to ground the sleeve

terminals of the trunks at the district (or office) frames. A sequence switch is provided at the panel office for each call indicator position to which trunks are provided. This "make-busy" switch, when advanced to a certain position, grounds the sleeve terminals of all trunks in this group. "Make-busy" switches are mounted on "Make-Busy Frames" in the panel office.

There are two methods of controlling the "Make Busy" sequence switches. By the first method each position is equipped with a "Make Busy" key. Operation of the "Make Busy" key at any position connects battery over a cable conductor to a circuit in the machine switching office which controls the sequence switch associated with the trunks to this RCI position. The switch is thus advanced to the position in which the sleeve terminal of each trunk in the group is connected to ground. To remove the busy condition the "Make Busy" key is restored to normal causing the switch in the machine switching office to advance to normal. The "Make Busy" keys are located on the face of the board above the subscriber's multiple.

The second method involves the use of selectors in the machine switching office to actuate the "Make Busy" switches. For each office to which RCI trunks are provided two terminals are set aside on a final frame in the machine switching office, one as a "Make Busy" number and the other as a "Make Idle" number. These terminals are common to all groups of trunks to a manual office while other terminals are assigned as group numbers, one for each call indicator position which has trunks from the panel office under consideration. To make the trunks from the panel office to any call indicator position busy, the supervisor or an "A" operator at the manual office calls the "Make Busy" number, the connection being established in the same manner as a regular subscriber's call. A second call is made for the "Group Number" which is assigned to the position to be taken out of service. With these two connections established the "Make Busy" switch, associated with the particular group of trunks which it is desired to make busy is advanced to the busy position. A distinctive tone is then transmitted to the manual office over the second connection to indicate that the trunks have been made busy. The supervisor then releases both connections and the selectors in the mechanical

office are returned to normal. To restore the trunks to service, the "Make Idle" number and the "Group Number" are called and the control circuit at the panel office advances the "Make Busy" sequence switch to its normal position. A different tone is transmitted to the manual office over the "Group" number connection to indicate that the busy condition has been removed. The release of the connections returns the selectors in the machine switching office to normal.

The first method requires a cable conductor from each position to the machine switching office which has trunks terminating at the position. If trunks from more than one office terminate on a position a conductor is required connecting these offices in series. If difficulty is encountered with differences of ground potential a pair of conductors is required. The second method does not require cable conductors; but in cases of trouble it is desirable to take a position out of service as quickly as possible and from this view point the first method is more satisfactory than the second. Therefore in deciding which of the two methods to use the cost of cable conductors should be compared with the undesirable traffic feature of the second method.

It is usually desirable during hours of light traffic to be able to vacate all but one or two "night" positions and to be able to complete all calls at these positions. For this purpose one or more positions are provided at which a few trunks from each machine switching office are terminated. By making all other positions busy, as described above, all calls will be completed at the "night" positions.

Parts of the sender, trunk, and RCI control circuits are shown schematically in Fig. 4. The RCI impulse switch (R4) in the sender circuit is advanced as soon as the class switch has been set either to position 17 "Awaiting start for RCI Direct" or to position 9 (position 5 on three-digit senders) "Awaiting start for RCI Tandem". The trunk test circuit cannot be closed by the sender on RCI class calls until dialing has been completed so as not to light the trunk assignment lamp in the manual office until the sender is ready to transmit the pulses corresponding to the called number. The time measure switch allows from 3 to 4 seconds additional time for the setting of the stations register on RCI class calls when there may be a party designation

diald or when the number may be above 9999. Dialing having been completed, the sender (S) relay releases closing the trunk test circuit which is traced from battery thru one winding of the (A) relay in the trunk circuit, over the T side of the trunk, thru the office, district, and link circuits, thru the sender (TG) and (OF) relays, back thru the link, district, and office circuits, and over the R side of the trunk to ground thru the other winding of the (A) relay. Note that the 14,500 ohm resistance which was included in the trunk test circuit on mechanical class calls is not included on RCI class calls. The (A) relay in the trunk circuit and the (TG) relay on the sender circuit operate. The operation of the (A) relay lights the assignment lamp; and the operation of the sender (TG) relay causes the operation of the sender (TGl) and (CI) relays, advancing the R2 switch to position 15, "RCI pulses". The operation of the "display key" at the manual position causes a number of operations one of which is the operation of the (I) relay in the trunk circuit. The operation of the (I) relay disconnects the trunk from the windings of the (A) relay and connects it to the RCI control circuit. The (TG) relay in the sender is thus released, in turn releasing the (TGl) relay. The release of the (TGl) relay closes a circuit for advancing the RCI impulse switch (R4) from the Start position thru the remaining positions of the first revolution and thru an entire second revolution. During this advance of the (R4) switch, battery and ground are connected to the T and R sides of the trunk in such a manner as to cause the transmission of a code of current pulses thru the winding of the (SN+) (SN-) and (MG) relays in the RCI control circuit. The pulses which are transmitted depend upon the setting of the office code and numerical registers on a tandem RCI call, and upon the setting of the numerical registers alone on a direct RCI call. Four circuit conditions are set up by the sender for each letter of number to be transmitted. The first and third of each of these sets of four conditions may be such as to transmit a light positive pulse or may be such as to transmit no pulse (open circuit). The second and fourth of each of these sets of 4 conditions may be such as to transmit a light negative pulse, a heavy negative pulse, and may be an open circuit with no pulse sent. A negative pulse is transmitted when negative battery is

connected to the ring side and ground is connected to the tip side of the trunk; and a positive pulse is transmitted when negative battery is connected to the tip side and ground is connected to the ring side of the trunk. A heavy pulse is transmitted when the battery is connected through a 52.5 ohm resistance in parallel with a 6500 ohm resistance, and a light pulse when it is connected through the 6500 ohm resistance only. The 4 circuit conditions for each digit are established in 4 successive positions of the RCI switch in the following order on RCI direct calls for numbers below 10000: Stations, thousands, hundreds, tens and units. On tandem RCI calls the pulses are transmitted in the order A, B (and C in 3 digit areas), stations, thousands, hundreds, tens and units. On calls to numbers above 9999 the pulses controlled by the setting of the stations register are sent after those controlled by the setting of the units register, instead of being sent immediately preceding those pulses controlled by the setting of the thousands register. The tables in Figure 5 show what pulses are sent for each digit as controlled by each register and also shows the positions of the R4 switch in which these pulses are sent by both 2 and 3 digit senders. The senders are also arranged so as to transmit a heavy positive pulse after all of the office code and numerical pulses have been transmitted. This pulse is necessary when a call is completed thru a "two-wire office selector" which will be considered in a later chapter.

Referring to figure 5 and assuming the called number to be 3974-J the pulses for the letter "J" will be sent in positions 17, 18, 19 and 20 of the first revolution of the R4 switch; the pulses for the digit 3 will be sent in positions 1, 2, 3 and 4 of the second revolution; the pulses for the digit 9 will be sent in positions 5, 6, 7 and 8; the pulses for the digit 7 will be sent in positions 9, 10, 11 and 12; and the pulses for the digit 4 will be sent in positions 13, 14, 15 and 16. The 4 conditions for the party designation J will be, - open circuit, light negative pulse, light positive pulse, and light negative pulse; the 4 conditions for the thousands digit 3 will be, - light positive pulse, light negative pulse, open circuit, and heavy negative pulse; the 4 conditions for the hundreds digit 9 will be, - open circuit, light negative pulse, light positive pulse, and heavy negative pulse. The 4 condi-

tions for the tens digit 7 will be, - open circuit, heavy negative pulse, open circuit, heavy negative pulse; and the 4 conditions for the units digit 4 will be the same as were sent for the party designation "J".

The RCI position control circuit receives these pulses through two polarized and one marginal relay and records each set of 4 pulses on sets of register or lamp control relays. One of the polarized relays (SN-) operates on a negative pulse and non-operates on a positive pulse; the other polarized relay (SN+) operates on a positive pulse and non-operates on a negative pulse. The (MG) relay non-operates on a light pulse and operates on a heavy pulse irrespective of their polarity. When the pulses for the letter "J" are received open circuit has no effect, the light negative pulse operates the (SN-) relay, the light positive pulse releases the (SN-) relay and operates the (SN+) relay, and the light negative pulse releases the (SN+) relay and reoperates the (SN-) relay. The first operation of the (SN-) relay operates the (W) relay but does not operate the (Z) relay. The release of the (SN-) relay causes the operation of the (Z) relay and holds the (W) relay through the make contact of the (W) relay. The operation of the (SN+) relay with the (W) relay operated, operates the lamp control relay (C). The (C) relay locks and closes a circuit that will light the (J) lamp as soon as all pulses have been received. Release of the (SN+) relay has no effect but the reoperation of the (SN-) relay short circuits the (W) relay causing its release but holding the (Z) relay operated. The operation and release of the (W) relay transfers the circuits controlled by the (SN+), (SN-) and (MG) relays from the first to the second set of register or lamp control relays so that the next set of 4 conditions set up by the impulse switch in the sender will cause those register relays to be operated which are necessary in lighting the "3" thousands lamp. In a similar manner each set of 4 conditions set up by the impulse switch in the sender causes certain lamp control relays to be operated as are required for lighting the proper lamp in each group of lamps. When the pulses for the units digit have been received the lamps are lighted, and when the operator inserts the plug of the trunk in a multiple jack of the called line the control circuit is released and the display on the call indicator extinguished. Since the impulse switch

in the sender has completed sending the ROI impulses the sender makes talking selection and returns to normal in a similar manner to that described for a mechanical class call. The connection is under control of the calling subscriber and when the receiver is replaced on the hook at the calling station the district returns to normal, opening the trunk and causing the DISC lamp at the manual position to light. The operator then removes the plug of the trunk from the multiple jack and the DISC lamp is extinguished.

In the following table is shown the operation of the assignment and disconnect signals under different circuit conditions.

	<u>Assignment Lamp</u>	<u>Disconnect Lamp</u>
1. Trunk selected by the switching apparatus. Display key not depressed, and trunk not up in the multiple.	Steady	Out
2. Trunk selected by the switching apparatus. Display key in home position depressed. Trunk not up in the multiple.	Flashes	Out
3. Same as condition No. 2, except team work display key is depressed instead of home key.	Flickers	Out
4. Trunk selected by switching apparatus. Display key depressed and trunk plugged into a multiple jack; or another display key has been depressed later.	Out	Out
5. Calling subscriber (or special operator) disconnects, causing the switching apparatus to disconnect.	Out	Steady
6. Call indicator trunk cord removed from multiple in error.	Steady	Out
7. Trunk which is still plugged up in the multiple from a previous call is selected by the switching apparatus on a new call.	Steady	Steady

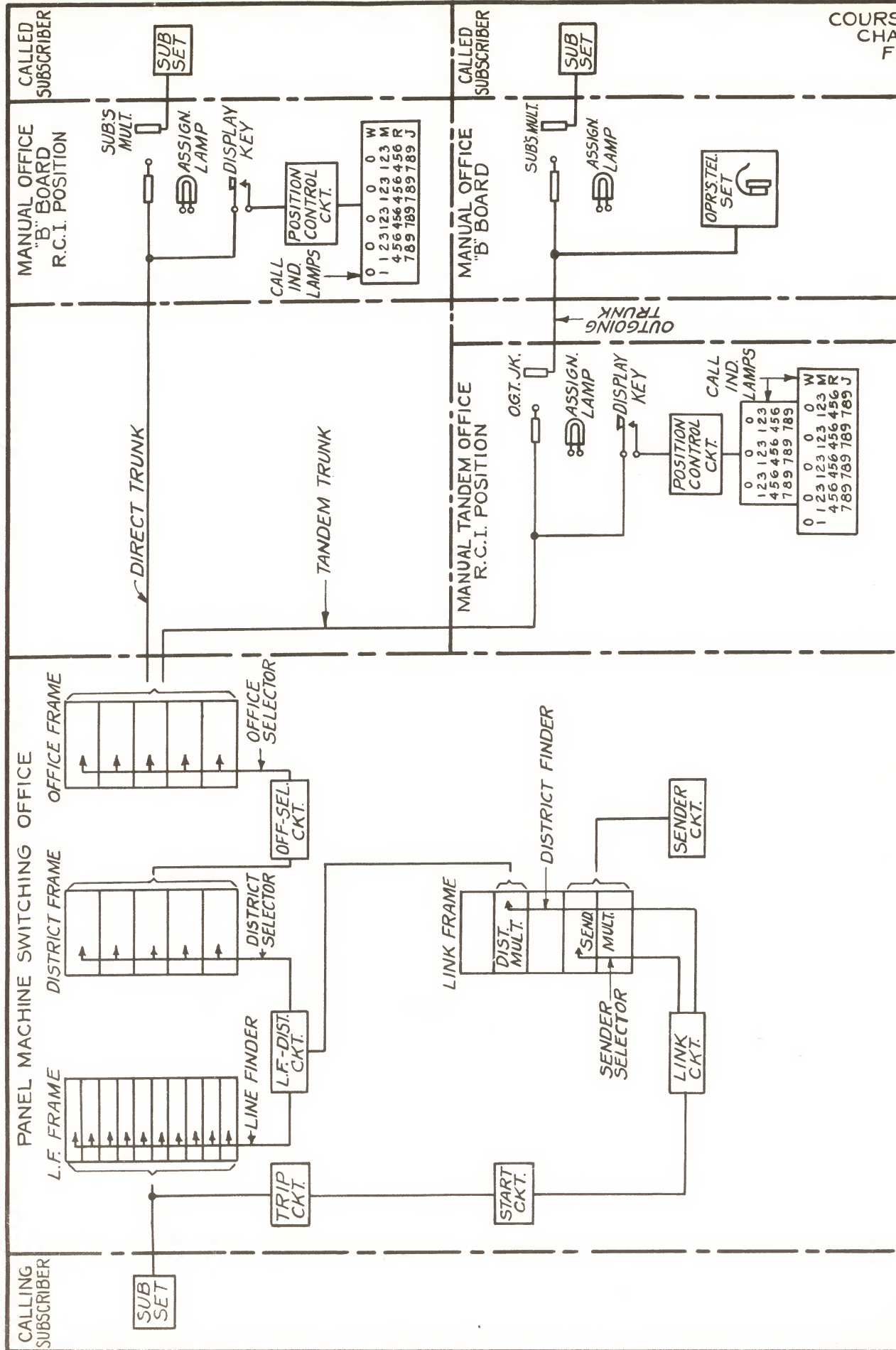

ROUTE OF A CALL FROM A PANEL TO A MANUAL OFFICE
 USING DIRECT OR TANDEM RELAY CALL INDICATOR TRUNKS
FIG. 1

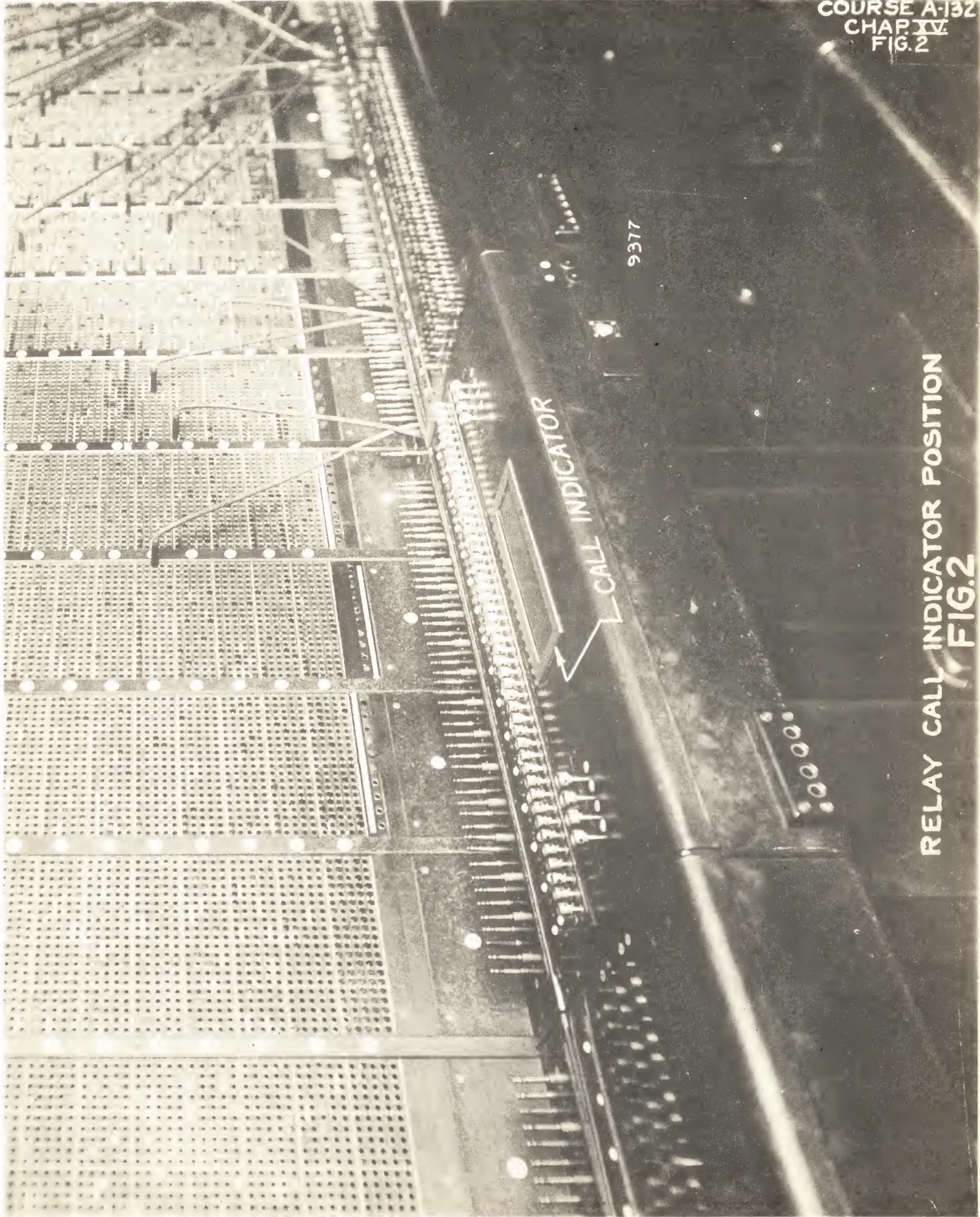

RELAY CALL INDICATOR POSITION
FIG. 2

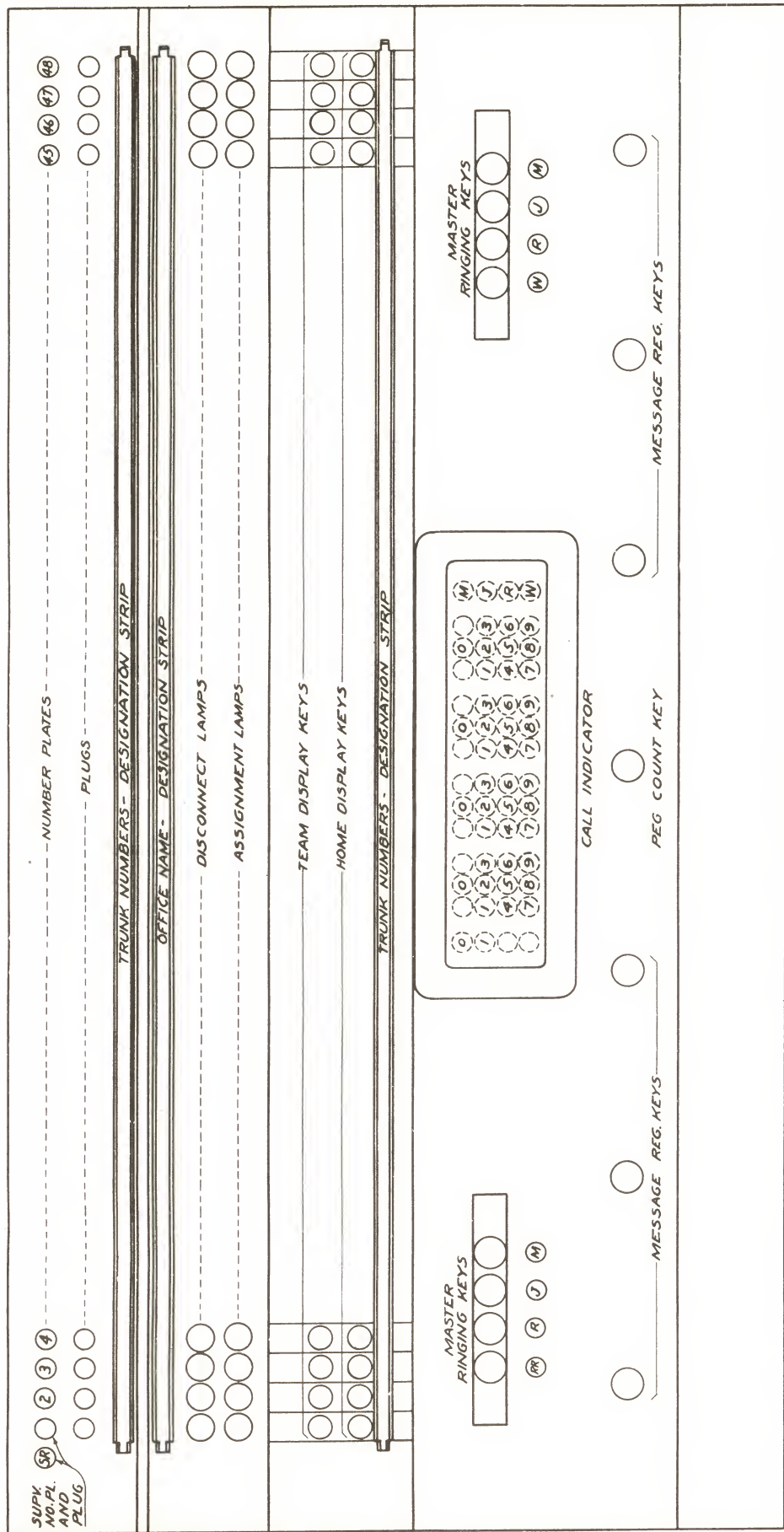

R.C.I. POSITION
 NO. 1 "B" SWITCHBOARD
 FIG. 3

LAMP		LAMP		PULSES	
STA	TH	NUM	RELAYS	REQU	REQU
		TENS	OPER'D	IR	IR
		UNITS			
0	0	0	NONE	-	-
1	2	1	A	+	-
W	4	2	B	-	-
R	6	3	A,B	+	+
V	8	4	C	-	-
M	1	5	D	+	+
3	6	A,D	-	-	-
5	7	B,D	+	+	+
7	8	A,B,D	+	+	+
9	9	C,D	-	-	-

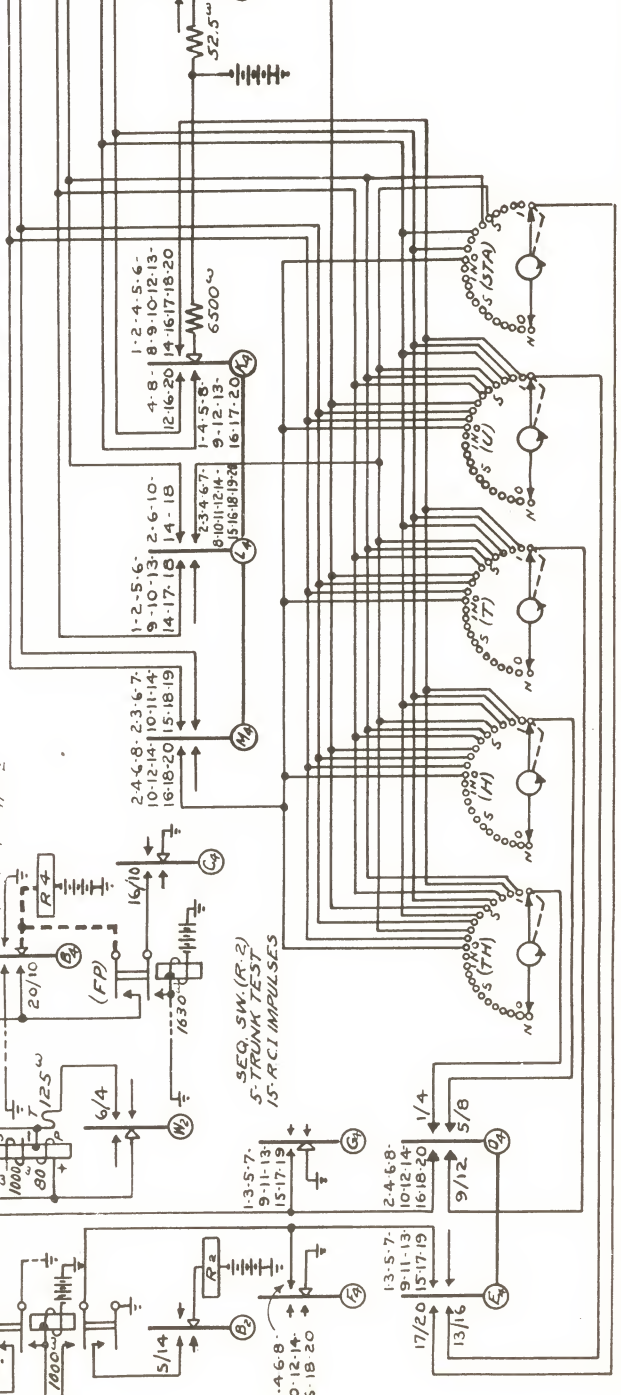
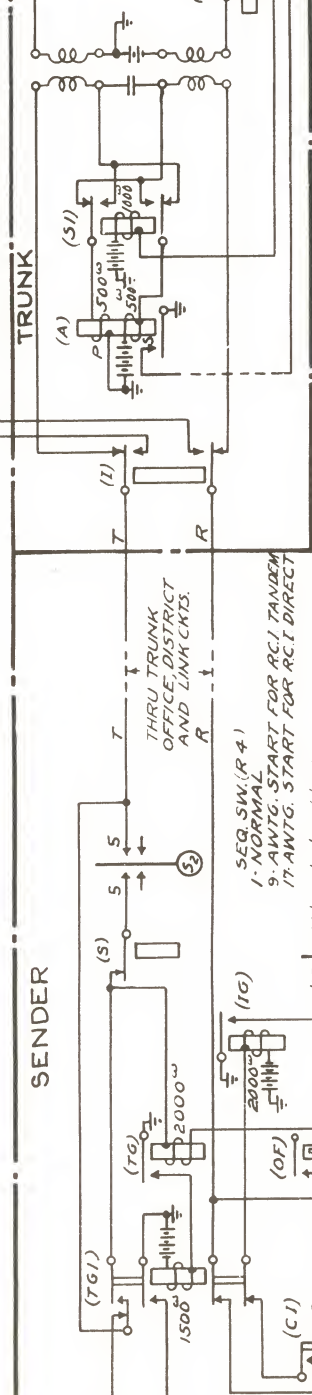
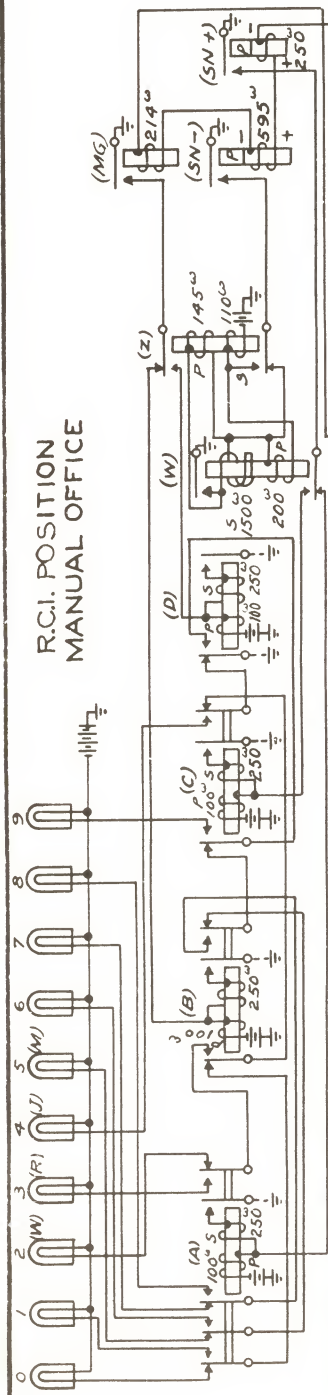

SENDING AND RECORDING IMPULSES FOR RELAY CALL INDICATOR CALLS
FIG. 4

SUBSCRIBER'S SENDER R.C.I. CONTROL										
DIALED			TRANSMITTED							
DIGITS			DIGITS			PULSES				
CODE	NO.	STA.	CODE	TH	H-T-U	STA.	1	2	3	4
	1			2	1		+	-		-
A.B.C.	2		A.B.C.	4	2	W		□		-
D.E.F.	3		D.E.F.	6	3	R	+	□		-
G.H.I.	4		G.H.I.	8	4	J		-	+	-
J.K.L.	5	J	J.K.L.	1	5	M		-		□
M.N.O.	6	M	M.N.O.	3	6		+	-		□
P.R.S.	7	R	P.R.S.	5	7			□		□
T.U.V.	8		T.U.V.	7	8		+	□		□
W.X.Y.	9	W	W.X.Y.	9	9			-	+	□
	0			0	0			-		-

TWO-DIGIT LINK SENDER							
	REGISTERS		PULSE				
	UNDER 10,000	OVER 9999	1 ST	2 ND	3 RD	4 TH	
REVOLUTION	1 ST	A	A	$8\frac{3}{4}/9\frac{1}{4}$	$9\frac{3}{4}/10\frac{1}{4}$	$10\frac{3}{4}/11\frac{1}{4}$	$11\frac{3}{4}/12\frac{1}{4}$
		B	B	$12\frac{3}{4}/13\frac{1}{4}$	$13\frac{3}{4}/14\frac{1}{4}$	$14\frac{3}{4}/15\frac{1}{4}$	$15\frac{3}{4}/16\frac{1}{4}$
		STA	TH	$16\frac{3}{4}/17\frac{1}{4}$	$17\frac{3}{4}/18\frac{1}{4}$	$18\frac{3}{4}/19\frac{1}{4}$	$19\frac{3}{4}/20\frac{1}{4}$
		TH	H	$20\frac{3}{4}/1\frac{1}{4}$	$1\frac{3}{4}/2\frac{1}{4}$	$2\frac{3}{4}/3\frac{1}{4}$	$3\frac{3}{4}/4\frac{1}{4}$
	2 ND	H	T	$4\frac{3}{4}/5\frac{1}{4}$	$5\frac{3}{4}/6\frac{1}{4}$	$6\frac{3}{4}/7\frac{1}{4}$	$7\frac{3}{4}/8\frac{1}{4}$
		T	U	$8\frac{3}{4}/9\frac{1}{4}$	$9\frac{3}{4}/10\frac{1}{4}$	$10\frac{3}{4}/11\frac{1}{4}$	$11\frac{3}{4}/12\frac{1}{4}$
		U	STA	$12\frac{3}{4}/13\frac{1}{4}$	$13\frac{3}{4}/14\frac{1}{4}$	$14\frac{3}{4}/15\frac{1}{4}$	$15\frac{3}{4}/16\frac{1}{4}$
		HEAVY POSITIVE PULSE			$17\frac{3}{4}/18\frac{1}{4}$		

THREE-DIGIT LINK SENDER						
	REGISTERS		PULSE			
	UNDER 10,000	OVER 9,999	1 ST	2 ND	3 RD	4 TH
	A	A	$4\frac{3}{4}/5\frac{1}{4}$	$5\frac{3}{4}/6\frac{1}{4}$	$6\frac{3}{4}/7\frac{1}{4}$	$7\frac{3}{4}/8\frac{1}{4}$
	B	B	$8\frac{3}{4}/9\frac{1}{4}$	$9\frac{3}{4}/10\frac{1}{4}$	$10\frac{3}{4}/11\frac{1}{4}$	$11\frac{3}{4}/12\frac{1}{4}$
	C	C	$12\frac{3}{4}/13\frac{1}{4}$	$13\frac{3}{4}/14\frac{1}{4}$	$14\frac{3}{4}/15\frac{1}{4}$	$15\frac{3}{4}/16\frac{1}{4}$
	STA	TH	$16\frac{3}{4}/17\frac{1}{4}$	$17\frac{3}{4}/18\frac{1}{4}$	$18\frac{3}{4}/19\frac{1}{4}$	$19\frac{3}{4}/20\frac{1}{4}$
	TH	H	$20\frac{3}{4}/1\frac{1}{4}$	$1\frac{3}{4}/2\frac{1}{4}$	$2\frac{3}{4}/3\frac{1}{4}$	$3\frac{3}{4}/4\frac{1}{4}$
	H	T	$4\frac{3}{4}/5\frac{1}{4}$	$5\frac{3}{4}/6\frac{1}{4}$	$6\frac{3}{4}/7\frac{1}{4}$	$7\frac{3}{4}/8\frac{1}{4}$
	T	U	$8\frac{3}{4}/9\frac{1}{4}$	$9\frac{3}{4}/10\frac{1}{4}$	$10\frac{3}{4}/11\frac{1}{4}$	$11\frac{3}{4}/12\frac{1}{4}$
	U	STA	$12\frac{3}{4}/13\frac{1}{4}$	$13\frac{3}{4}/14\frac{1}{4}$	$14\frac{3}{4}/15\frac{1}{4}$	$15\frac{3}{4}/16\frac{1}{4}$
	HEAVY POSITIVE PULSE			$17\frac{3}{4}/18\frac{1}{4}$		

R.C.I. PULSE CODE
 FIG. 5

PANEL SYSTEM "B" SWITCHBOARD
AND ASSOCIATED EQUIPMENT

There are three methods by which calls from lines in manual offices are completed to lines in panel offices, as follows: (1) by use of a "Panel System B" switchboard in the panel office, (2) by use of "Key Indicator" equipment in the manual office and (3) by equipping each "A" position in the manual office with a dial and dial key. The use of a panel system "B" switchboard will be considered in this chapter, the other two methods being considered in the next chapter.

The use of a "B" board in the Panel office makes unnecessary any change in the Manual office and calls to Panel offices are handled by the "A" operator in identically the same manner as calls to Manual Offices. In fact neither the calling subscriber nor the "A" operator need know in what type of office the called subscriber is located. The trunks from the Manual office to the Panel office may be arranged either for call circuit or straightforward operation and connect to incoming selector circuits on incoming frames in the panel office. The trunks are also multiplied to a panel type multiple bank on a "B Sender and Link Frame" but do not terminate as a cord and plug at the "B" position as do the "plug ended" trunks at manual "B" positions. For that reason the term "Cordless" is commonly applied to this "B" board and to the incoming selector circuits.

With reference to call circuit operation the "A" operator repeats the called number to the machine switching "B" operator who assigns an idle trunk. The "A" operator inserts the plug of the calling cord into a multiple jack of the assigned trunk lighting a "GUARD" (White) Lamp at the "B" position. The "B" operator depresses the assignment key which is associated with the lighted lamp and also depresses numerical recording keys corresponding to the called number. Operation of the assignment key causes a "B" link circuit to connect an idle "B" sender to the assigned trunk, the link and sender being mounted on a "B Sender and Link (Panel Type) Frame". This sender then causes incoming and final selections to be made, according to the numerical keys which were depressed, so as to connect the calling subscriber to the called subscriber. The equipment involved

in completing such a call is shown schematically in Figure 1. The connection is under the supervision and control of the "A" operator in the originating office and the "GUARD" Lamp and a "BUSY" (Green) Lamp, which are associated with this trunk, indicate the various conditions which exist during the establishing of the connection as follows:

<u>Condition</u>	<u>Guard Lamp (White)</u>	<u>Busy Lamp (Green)</u>
Normal	Out	Out
Calling Cord Plugged Into Trunk Multiple Jack	Steady	Out
Last Numerical Key Depressed Selections Not Completed	Out	Flicker
Ringing and Talking	Out	Steady
Disconnect	Flash	Flash
Paths Busy	Flicker	Out

A Panel system (or cordless) "B" switchboard is shown in Figure 2 and the keyshelf equipment is shown in Figure 3. The board consists of low desk type sections, two positions to a section. The keyshelves are sloped at the angle shown in order to make the trunk keys and numerical recording keys as accessible to the operator as possible. Each trunk has associated with it an "assignment" key, a "disconnect" key, a White "GUARD" Lamp and a Green "BUSY" Lamp. The lamps and keys are mounted on the upper keyshelf in two rows, 30 trunks per row with designation strips for trunk numbers and office names just below each row. A set of numerical recording keys are mounted in the middle of the lower keyshelf on which to record the number of the called line. The key sets are removable and one emergency set is provided for every 10 positions. Should the regular set at any position become defective the emergency set can be substituted and service maintained. Each recording key set consists of four groups of 10 keys each, numbered from 0 to 9 inclusive. The keys are manually operated and electrically released.

Thus, each cordless "B" position handles the traffic incoming over a maximum of 60 trunks which connect to incoming selectors mounted on an incoming frame. Each position is served by 6 link circuits, 2 allotter circuits, and 2 key control circuits, the apparatus for three positions being mounted on each "B

Sender and Link Frame". All of the cordless "B" positions are served by a common group of "B" senders there being a maximum of eight of these common senders mounted on each "B Sender and Link Frame". The "B Sender and Link Frame" and the three incoming frames, which serve three positions are located in a row. The incoming frames are similar to those on which incoming selectors from panel type offices are mounted, as shown in Figure 3 Chapter 13. The "B Sender and Link Frame", shown in Figures 4 and 5, is a double sided frame somewhat similar to the panel link frame described in Chapter 5. The framework is divided into three bays. The end bays (one for the front of the frame and the other for the rear of the frame) are used for mounting the motors, fuse panels, sequence switches, patching jacks and terminal strips. The upper portion of the middle bay is divided vertically into two halves, one of which is used for mounting the relays, condensers and resistances for the senders, links, allotters and key control circuits whose sequence switches and panel selectors are located on the front of the frame. The other half is used for mounting this apparatus for the senders, links, allotters and key control circuits whose sequence switches and panel type selectors are located on the rear of the frame. With this arrangement the equipment which serves each position is divided between the front and rear of the frame so that, if the motor on one side should stop, the position would not be deprived of service as long as the motor on the other side of the frame continued to run. The lower part of the middle bay is used for mounting the commutators, trunk and sender multiple banks, trunk finders, sender selectors friction roll drive, keys and jacks. The relay bays in the upper half are protected both at the front and the rear by dust-proof casings with metal doors.

Each link circuit includes a trunk finder, a sender selector, a sequence switch and a number of relays. Since more than three leads are required to and from the link circuit, each trunk finder and sender selector brush rod has two multiple brushes one for each of a pair of multiple banks. Each bank consists of 65 sets of three terminal strips each. The pair of banks at one end of the frame furnishes the trunk finder multiple for the trunk finders associated with positions 1 and 2. These banks are split vertically in the middle so that the six trunk finders (three on each side of the frame) which are associated with

each of these two positions have individual trunk multiple. A pair of banks at the other end of the frame is split vertically so that the inner section furnishes the individual trunk multiple for the six trunk finders (three on each side of the frame) associated with position 3; the outer or end section of these banks furnishes the sender multiple for the 9 sender selectors (three for each position) on each side of the frame. The brushes which make contact with the terminals in the upper banks are bridging brushes while those associated with the lower banks are non-bridging. The brushes are permanently tripped and the brush rods are returned to normal after each connection has been established.

Each allotter circuit includes a sequence switch and a number of relays. One of the two allotter circuits associated with each position allots the three links located on one side of the frame and the other allotter circuit allots the three links located on the other side of the frame. The three links on the front of the frame are allotted on three successive calls and then the three links on the rear of the frame are allotted on the next three successive calls handled at this position.

A key control circuit includes a sequence switch and a number of relays there being two key control circuits provided for each position. They are used alternately on successive calls thus permitting the starting of a second call as soon as the recording keys are released without waiting for the key control circuit to return to normal. If one of the key control circuits should become defective the other key control circuit is used on all calls, and it is to insure continuity of service that the second key control circuit is provided.

Each sender consists of one sequence switch and a number of relays, condensers and resistances. The apparatus for senders A, B, C and D is mounted on the front of the frame and the apparatus for senders E, F, G and H is mounted on the rear of the frame. Senders A, B, C and E, F, G are connected to the six bottom sets of terminals in the bank on the same frame on which the senders are located. Thus, when only six senders are equipped per frame the link sender selectors will always select a sender which is located on the same frame providing one of them is idle; but if all of the senders on this frame are busy the sender which is selected will be located on some other "B" sender or link frame.

The remaining sets of terminals in the sender multiple bank are connected in groups of six to the senders mounted on other frames, using multiple slip and reversal. When senders "D" and "H" are equipped, they are wired to the terminals in a group above the terminals which connect to the first six senders on the last regular "B" sender frame.

Those parts of the circuit involved in completing a call through a cordless "B" board which are required in following the operations described below are shown in Figure 6. Assuming that the trunks incoming to a cordless "B" position are operated as call circuit trunks, and the trunk having been assigned by the operator on a particular call, the assignment key associated therewith is depressed causing the incoming switch to advance to position 2. In position 2, the guard (white lamp) is lighted, and ground is connected to the hold (H), start (ST) and fundamental (F) leads. Ground is disconnected from the hunting (HT) lead when the switch advances from position 1 so that the panel trunk finder in the link circuit, which has previously been allotted for use on this call, will select and connect to this trunk. The ground on the (ST) lead operates the (T) relay in the link circuit. The (T) relay, operated, operates the (SH) relay, thus advancing the link switch to position 2. With the (T) relay operated, ground is connected to the trunk finder (G) commutator bar, and, with the switch in position 2, ground is connected to the sender selector (G) commutator bar. The circuit through the "P" winding of the (SH) relay is opened when the switch advances to position 2 but a circuit is closed through the "S" winding to ground to the (C) commutator brush and segment holding the (SH) relay operated. The sender selector "UP" magnet is operated in position 2 driving the sender selector brush rod upward. The bottom sleeve multiple brush (SH) is a bridging brush and the (SH) relay holds through its "P" winding to the grounded sleeve terminals of busy senders; but when the idle sender is reached, the circuit through the "P" winding is opened and as soon as the brush rod has travelled high enough to insure the pawl entering the slot in the rack which corresponds to the multiple terminals of the idle sender, the circuit through the "S" winding to ground through the (C) commutator brush and segment is also opened, releasing the (SH) relay. The release of the (SH) relay connects ground to the

(SH) multiple terminal so as to make the test busy to any other hunting sender selector. The release of the (SH) relay also advances the link switch to position 3. A permanent busy condition is connected to the (SH) multiple terminal as long as the link switch is in positions $2 \frac{3}{4} / 8 \frac{1}{4}$. With the link switch in positions $2/3$ and with the (T) relay operated, the trunk finder (UP) magnet is energized driving the trunk finder brush rod upward. The (T) relay holds through the (H) multiple brush to ground in the trunk circuit until the assigned trunk is reached. Since ground has been disconnected from the (H) multiple terminal of this trunk, the circuit through the "P" winding of the (T) relay is opened and when the trunk finder has traveled high enough to insure the pawl entering the slot in the rack which corresponds to the multiple terminals of the assigned trunk, the circuit through the "S" winding of the (T) relay to ground through the (C) commutator brush and segment is also opened releasing the (T) relay. The release of the (T) relay connects ground to the (H) multiple terminal so as to make it test busy to any other hunting trunk finder. The release of the (T) relay also operates the (H) relay thus advances the link switch to position 4. The operation of the (H) relay also operates the (HD) relay thus closing the holding circuit for the (H) relay through the (H) multiple brush and over the "H" lead to ground through the back contact of the (L) relay in the incoming circuit. Ground is connected directly to the sender selector (G) commutator bar in position $3 \frac{3}{4} / 18$. With the link switch in position 4, ground is connected to the "B" lead operating the (S) relay in the selector sender. The (S) relay locks through its "S" winding to this ground in the link circuit and advances the sender switch to position 2. The (SH) relay in the link circuit operates in position 4 of the link switch over the "F" lead to ground in the incoming circuit (incoming switch in position 2). The operation of the (SH) relay advances the link switch to position 5. The (SH) relay holds operated in this position. As soon as the "B" operator has depressed all of the keys corresponding to the called number a circuit is closed from ground in the key control circuit over lead "A" through the link circuit to the incoming circuit advancing the incoming switch to position 3. In position $2 \frac{3}{4} / 1$, the incoming connects ground directly to the "H" lead so as to hold the (H) relay in the link circuit operated until

the call is completed. In position 3, the guard (white lamp) is extinguished and the busy (green lamp) flickers under control of the progress interrupter (PR). When the incoming switch advances from position 2, it disconnects ground from the "F" lead releasing the link (SH) relay and thus advancing the link switch to position 6. In position 6, the link (KC) relay operates over lead "S" to battery in the key control circuit. The (KC) relay operated connects the "A" and "B" lead from the key control circuit through the sender circuit and while the link switch is in position 6/7 register relays are operated in the sender as controlled by the numerical recording keys which were depressed by the operator. The (KC) operated also operates the (SH) relay connecting the "C" lead from the key control circuit to the sender circuit and advancing the link switch to position 7. When the switch leaves position 6 the (KC) relay holds through the contacts of the (SH) relay and in position 6 3/4 / 16 ground is connected to the "Y" lead from the allotter circuit to advance the allotter switch to the next allotting position ready for the next call. When registration of the called number has been completed in the sender, the key control circuit opens the "S" lead, releasing the link (KC) relay. The release of the (KC) relay and consequent release of the (SH) relay opens the A, B and C leads and advances the link switch to position 8 in which position incoming and final selections are completed over the fundamental "F" lead from the incoming and the "B" lead to the sender. When incoming selections are completed and an idle trunk to a final selector has been selected, the incoming switch is advanced to position 11, selection beyond in which position the "F" lead is connected to the final and the (SH) relay in the link operates over the "FR" lead to ground in the final circuit. The (SH) relay operated operates the (T) relay and when final selections are completed, the sender connects ground to the "A" lead advancing the link switch to position 9. The final disconnects ground from the "R" lead when final selections are completed, thus releasing the link (SH) relay and advancing the link switch to position 10. In position 10, ground over the "A" lead advances the incoming switch out of the selection beyond position thereby disconnecting ground from the "H" lead and releasing the (H) relay. The (HD) relay is thus released advancing the link switch to position 11, in which position the "TF" and

"SS" down magnets are energized returning the trunk finder and sender selectors to normal. When the "TF" selector reaches normal ground to the "TF" (Y) commutator brush and segment operates the (SH) relay releasing the "TF" down magnet, and when the "SS" selector reaches normal, ground through the "SS" (Y) commutator brush and segment advances the link switch to position 13. Ground on the (B) cam advances the link switch to position 17 in which position the link awaits assignment by the allotter for use on a succeeding call. The sender was released and the busy ground removed from the "SH" terminal when the link switch advances from position 8 1/4.

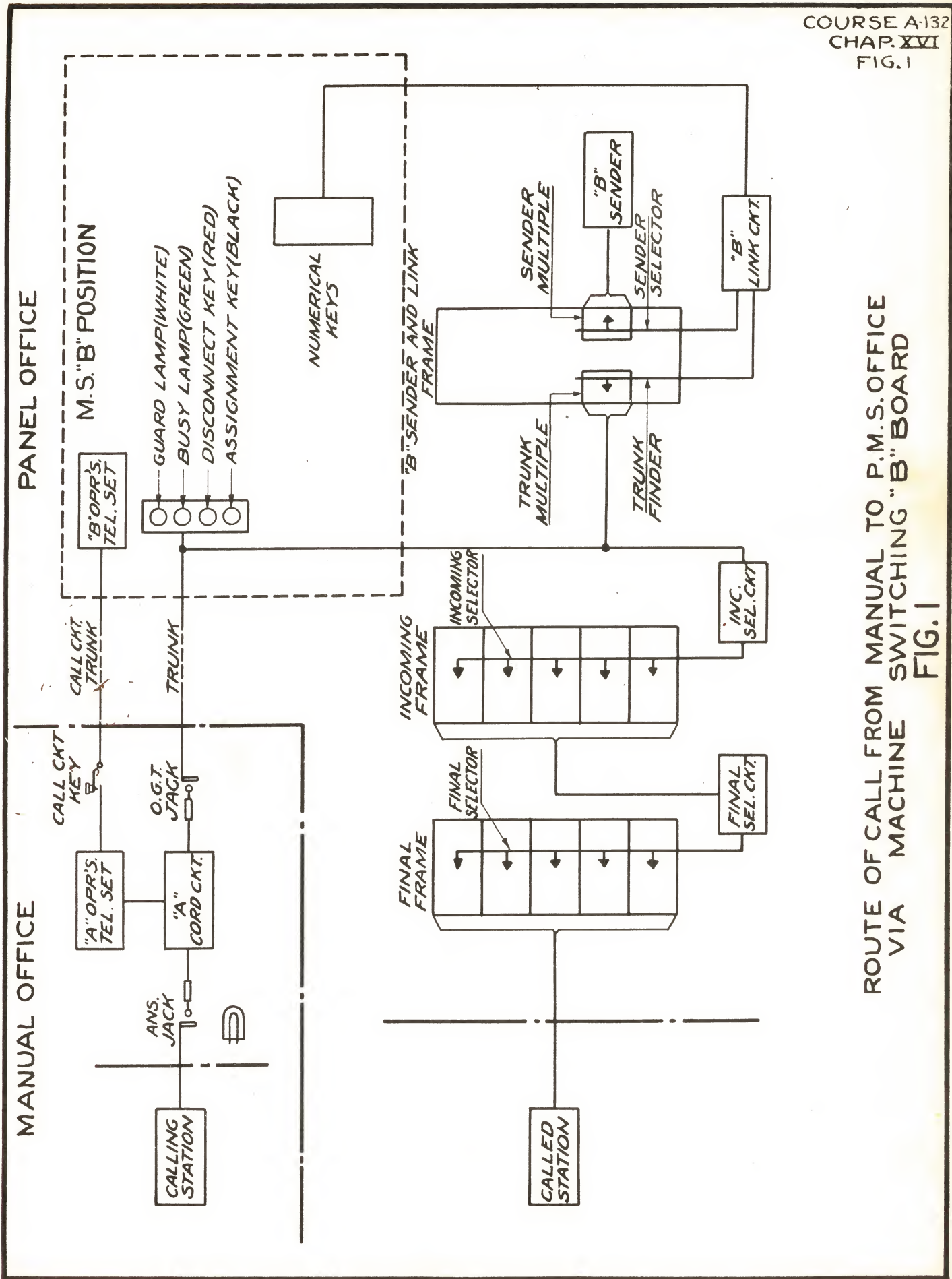

ROUTE OF CALL FROM MANUAL TO P.M.S. OFFICE
 VIA MACHINE SWITCHING "B" BOARD
 FIG. 1

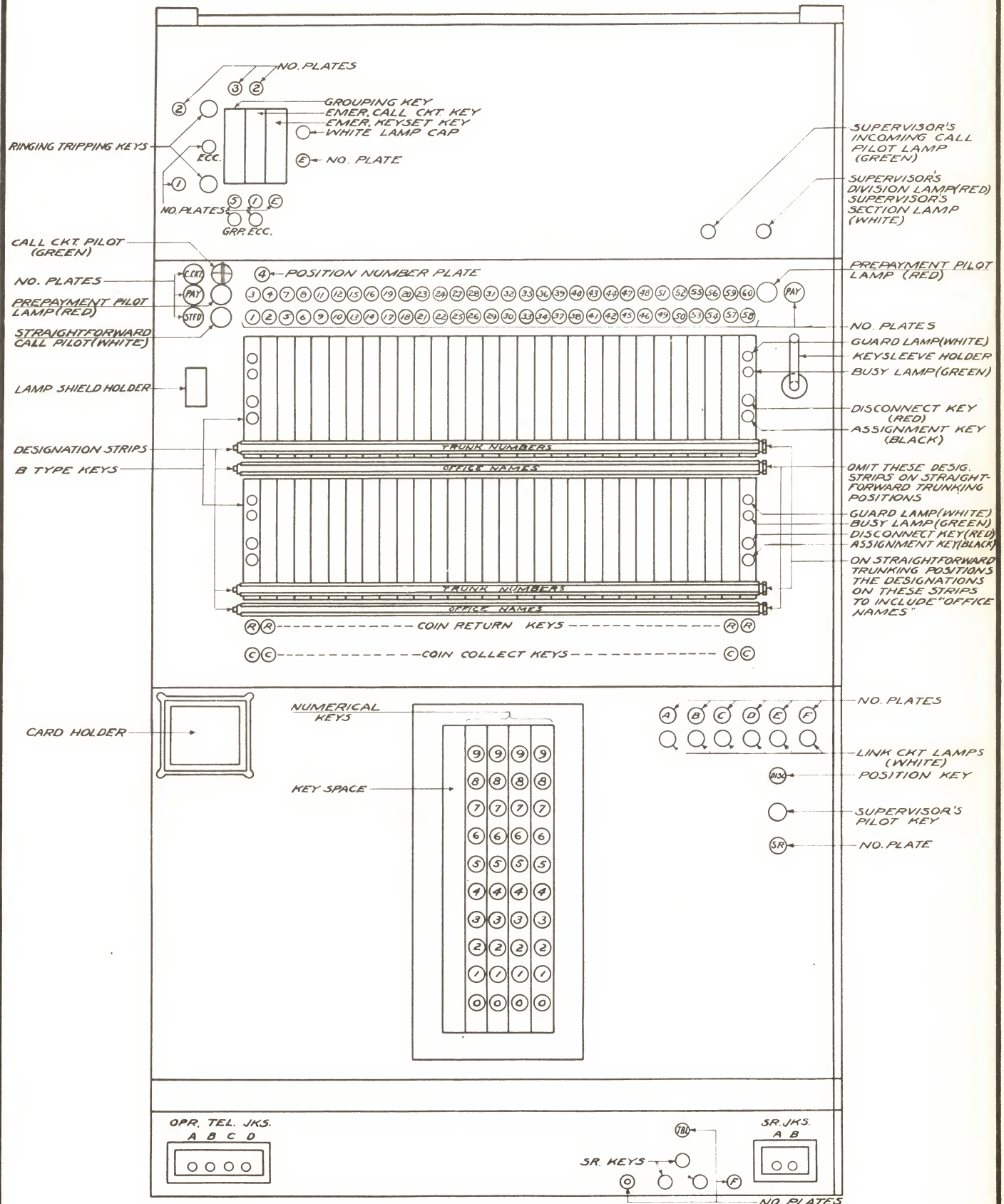

FRONT EQUIPMENT
 CORDLESS "B" SWITCHBOARD
 FIG. 3

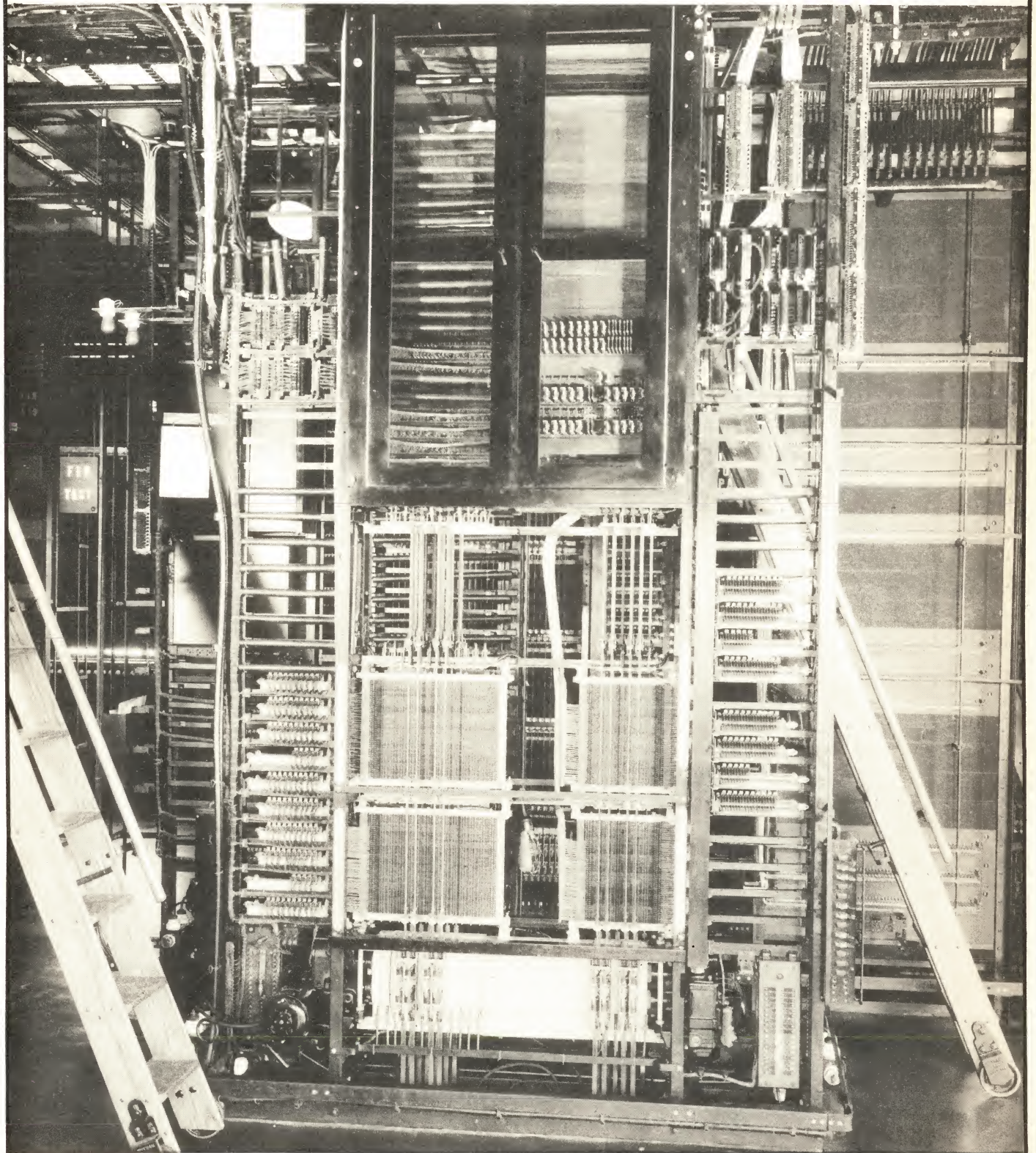

"B" SENDER AND LINK FRAME
FIG. 4

INCOMING SELECTOR CIRCUIT

COURSE A-132
CHAP. XVI
FIG. 6

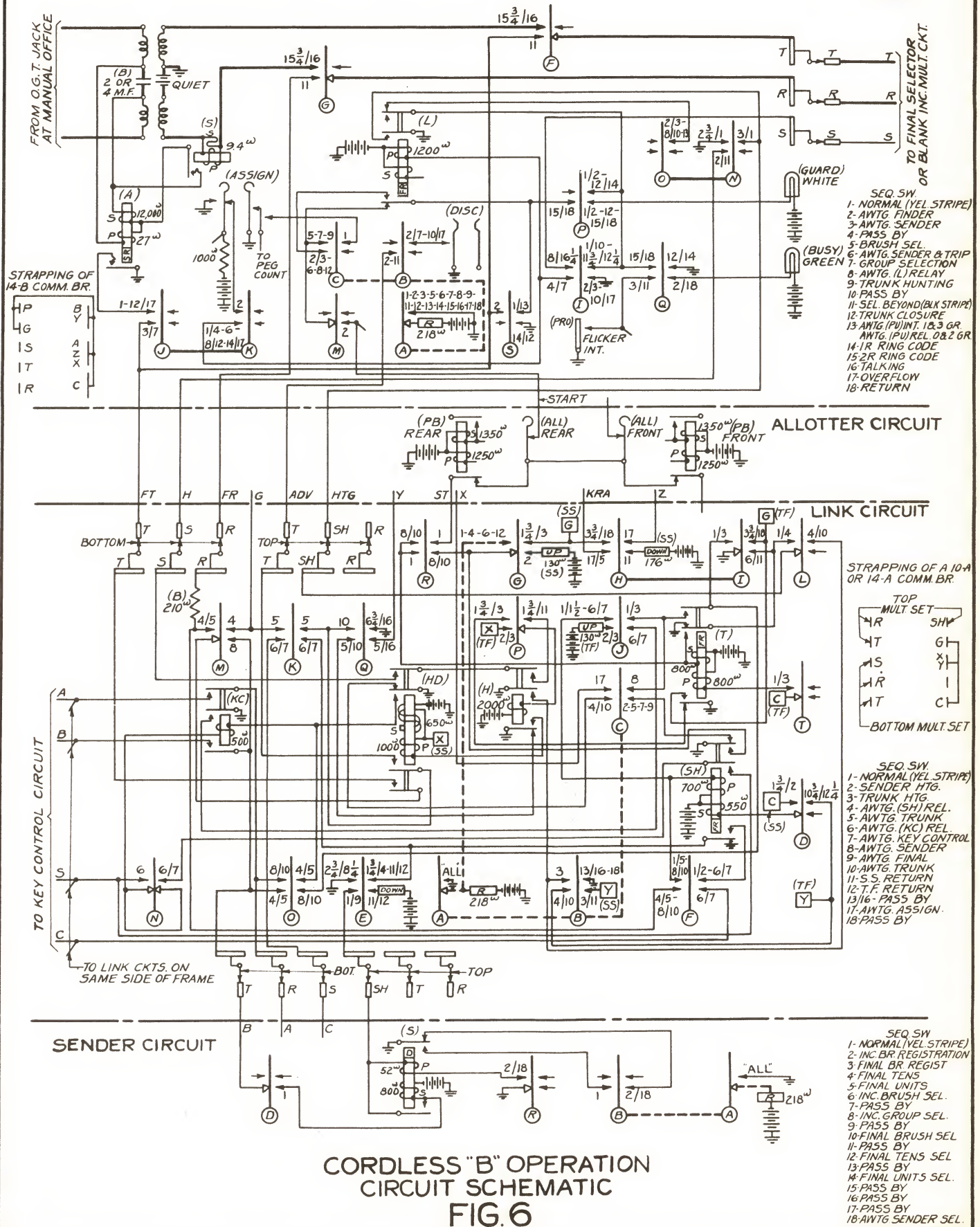

CORDLESS "B" OPERATION
CIRCUIT SCHEMATIC
FIG. 6

Call Distributing "B" Switchboard

Incoming trunks terminate directly on incoming selectors which are multiplied to a trunk finder bank of the "B" link. The "B" link is a three-way link consisting of a trunk finder, position selector, and sender selector. The trunk finder has access to the trunk finder bank having a capacity of 120 incoming selectors. The position finder has a capacity for 20 positions and the sender selector has access to a sender multiple with capacity for 100 senders. A link frame accommodates two link groups of 14 links each together with their associated start and trip circuit. Each link group is further divided into two subgroups "A" and "B" similar in circuit operation to the panel type line finder.

When a trunk is selected at the originating end, the selection causes the trunk finder selector of the "B" link to hunt for that trunk and its associated incoming selector. At the same time, the position selector starts hunting for an idle "B" operator's position. After the position is cut through to the trunk, order tone is sent out to the originating end and the sender selector starts hunting for an idle sender. When an idle sender is found, the "B" operator is informed of this condition, after which she plays up the call on her key set. When the sender is satisfied, the link releases the position and then the sender proceeds with fundamental selections in the usual manner. When selections are complete, the sender releases, which causes the link to be released. See Fig. 1.

Position Circuits

The position keyshelf is provided with a set of ten non-locking numerical keys numbered 0 to 9 on which the operator plays up the number, a non-locking reset key marked "RS", a non-locking position disconnect key marked "PD", a sender lamp (white) and a link lamp (green). The general arrangement of this equipment on the keyshelf is shown in Fig. 2.

In addition a supervisor's "call bell and pilot" key is provided on the left-hand position of each section, designated "SR". The white pilot lamp located on the top of each section is associated with the "SR" key.

A green jeweled lamp associated with the calls-waiting signal circuit is located on the top of the switchboard in each supervisor's division.

The supervisor's and operator's telephone jacks are mounted in the lock rail. Each position is wired so that when the operator's telephone plug is removed from the jack, the position will test busy to incoming calls.

An "A", Manual Tandem, or Toll operator on receiving an order for a Panel dial office number will plug into an idle trunk to that office in the usual manner. The plug-in of the operator will cause a circuit to be closed to start a link functioning as described above. When an idle "B" position is found, the link (green) lamp at that position starts flashing (120 I.P.M.). When the trunk is also found the sender (white) lamp on the position lights and the sender selector of the link starts hunting for an idle sender. At the same time, the order tone is sent back to the originating operator. The "B" operator will also hear this order tone. At the completion of this tone, the "B" operator's telephone circuit is cut in and she is ready to receive the order from the originating operator. At this point, the link lamp becomes steadily lighted.

The sender lamp goes out as soon as the sender selector of the link finds an idle sender. This interval will usually be less than one second. If the sender selector on the link is standing on an idle sender when the trunk is found, the sender lamp will light momentarily and then go out. In any event, a sender should generally be found before it is required by the "B" operator..

The "B" operator after obtaining the number from the originating operator can start to play it up on her key set immediately, provided the sender lamp is out. After the "B" operator has played up the four digits, the link lamp goes out and the link releases the position while the incoming and final selectors proceed with fundamental selections under control of the sender. As soon as the position is released by the link, it is available for another call. When final units selection has been completed, the link and sender are released, restoring the trunk finder to normal. The sender

selector also restores to normal at this time if it is standing on one of the top 20 terminals.

Reset Key

If the "B" operator depresses a wrong numerical key before playing up the units digit of the number, she may correct the error by first depressing the reset key "RS" and then, as soon as the sender lamp goes out, setting up the complete number again. The reset key in this case merely releases the register relays already operated in the sender and again prepares it for registration. If, however, the key corresponding to the units digit of the number has been depressed and released, correction cannot be made and the call will result in a wrong number.

In case the "B" operator depresses a numerical key before the sender is found as described in the preceding section, the sender lamp will start flashing (120 I.P.M.). In this case the momentary depression of the reset key will retire the sender lamp provided the sender has then been found. If the sender selector is still hunting, however, the depression of the reset key will cause the sender lamp to become steadily lighted until the sender is found.

Should the link lamp remain lighted after the last numerical key has been depressed, the "B" operator may depress the reset key and as soon as the sender lamp goes out play up the number again.

Position Disconnect Key

The position disconnect key "PD" is provided to allow the "B" operator to release her position from the link in case the green lamp flashes for an appreciable interval indicating a stuck link, or in case she cannot free her position by writing up the number on her numerical keys. The operation of this key will normally cause the link to free the position immediately. Under this condition the reorder signal will be sent back to the originating operator until she pulls down her cord, at which time the incoming selector, the sender and the link will attempt to release. The link and sender, however, may be held by the maintenance forces for tracing trouble as will be described later.

Unoccupied Position and Night Alarm Circuit

Positions are automatically made busy by the removal of the operator's plug from the jack. When all positions are busy or vacant the circuit functions to prevent any link circuit from hunting a position until one becomes idle. Should all positions become unoccupied a night alarm is automatically effective. A call coming in at that time will sound the night alarm bell. An operator can answer this call on any position to which all links have access.

Calls-Waiting Signal Circuit

A calls-waiting signal circuit is provided to give an indication to the operating force when calls are being delayed due to an insufficient number of "B" positions in service. A calls-waiting meter with three associated locking keys is mounted on the cable turning section at the end of the switchboard. See Fig. 3. This meter is wired so as to indicate the number of links attempting to find a position, provided the meter key is operated.

In case all the "B" positions are busy and four or more calls are waiting for operators, the alarm circuit will start to count time and will continue to count time as long as there are four or more calls waiting. At the end of 30 to 60 seconds, if this condition persists the green jeweled lamp located in each supervisor's division will light and a buzzer in the cable turning section will sound. A key is provided for the purpose of silencing the buzzer whenever this is found to be desirable. The operation of the meter key retires the lamps at the supervisors' divisions and as explained above, transfers the circuit to the milliammeter which is graduated directly in calls waiting. The third key is for the purpose of changing the circuit so that the alarm will come in only if seven or more calls are waiting instead of four or more.

A cable turning section, 1' 4-5/8" deep and 1' long, is provided for the end of a lineup of sections. The "calls waiting" meter with the associated keys and relays and the night alarm equipment are located at this point. The capacity of the cable turning section is such that a maximum of approximately 40 positions can be placed in a single lineup. See Fig. 3.

Key Monitoring

Where specified, key monitoring equipment is furnished as part of the "B" switchboard installation. This equipment permits a central office instructor at a monitoring desk to listen in on the telephone set of any position and, at the same time, receive by means of a lamp indicator arrangement a complete record of the operation of the keys and lamps at the position.

The instructor plugs the monitoring cord into the jack corresponding to the "B" position on which observations are desired. Taps from the "B" operators telephone circuit are connected to the tip and ring of this jack and over this circuit the instructor hears the order tone and all verbal orders passed to the "B" operator. Three monitoring relays at the "B" position operate over the sleeve of the jack, to extend the key set leads, link and sender lamp leads, and leads from the reset and position disconnect keys to the monitoring desk. These leads are held open at the monitoring desk until any call which is in progress through the position has been completed.

With the monitoring desk ready to record a call the link lamps (green) both at the "B" position and the monitoring desk flash when the position is seized by a link. When the trunk is found these lamps change to a steady condition and the order tone is sent out. The order tone is heard by the "B" operator, the "A" operator and the instructor. Also, when the trunk is found the sender lamps (white) light at both the position and the monitoring desk indicating that a sender is being hunted.

When the sender is found the sender lamps go out and the "B" operator proceeds to play up the number requested. As the key corresponding to each digit is depressed the digit is displayed on the indicator at the monitoring desk.

When the registration in the sender is completed and the "B" position circuit is dismissed the "WO" lamp at the monitoring desk lights to indicate this condition and the link lamp goes out. The numerical display, however, is locked in and all the leads from the position to the monitoring desk with the exception of the listening circuit are opened. When the

instructor has noted the display she depresses the release key which wipes out the display and puts the monitoring desk in condition to record another call.

Link, Trip and Start Circuit

The link as described previously consists of a trunk finder, position selector and sender selector together with the necessary control apparatus all mounted on a common frame. This equipment is shown schematically in Fig. 4. The equipment layout in Fig. 5 will be described in a separate paragraph.

A trip-and-start circuit is provided per link group which is divided into two separate halves, one for starting the "A" subgroup of links and the other for starting the "B" subgroup of links.

The trunk finder portion of the link is a panel selector similar in design and operation to the panel line finder. Each trunk finder has access to a maximum of 120 incoming selectors which appear on two panel banks similar to the banks used on line finder frames, but having 60 terminals. These banks are split in the middle thereby providing for two groups of a maximum of 120 incoming selectors each. A link frame, therefore, has capacity to serve 240 incoming selectors.

The position selector consists of a 206-type selector with a capacity of 20 positions. Suitable means are provided at the link frame for connecting the position selector terminals to the positions to permit grading where more than 20 positions are required.

The sender selector is a panel selector hunting over two 100-terminal banks. The two banks in this case are provided to give the necessary six leads to each sender. The senders are, therefore, used in groups of 100 or less. The sender-selector is almost identical to that employed by the subscribers' panel link, the selector remaining on the sender terminals between calls except after serving a call through one of the top 20 terminals in the multiple. In this case the selector returns to normal.

The link circuit sequence switch makes only one-half revolution per call allowing two complete calls per switch revolution. The operation of the

circuit for the last half revolution is identical with that of the first half.

The function of starting a link and the tripping of the proper brush of the trunk finder is controlled by the trip-and-start circuit. A signal over the start lead from the incoming selector causes the trip-and-start circuit to begin functioning. During the time a trunk finder is hunting for a trunk, the trip-and-start circuit prevents another call from starting a link in that subgroup until this trunk is found; however, it is possible to start a link in each subgroup simultaneously provided links are available in each subgroup. A transfer circuit is provided so that when one subgroup of links is busy the calls which would normally be served by that subgroup are transferred to the other subgroup of the same link group. With this arrangement, when a trunk is selected by an "A", manual tandem, or toll operator the trunk finder in the proper subgroup is started if one is available. If, however, the links in that subgroup are all busy a trunk finder in the other subgroup will be started, provided they too are not all busy. In this case the trunk finder will travel into the upper half of the bank to find the trunk. Since the two halves of a trip-and-start circuit are largely independent electrically, that part of the circuit serving one subgroup of links may be taken out of service and worked on without interfering with light hour service. For this reason no emergency trip-and-start circuit is furnished.

While the trunk finder is hunting for the trunk, the position selector is started hunting for an idle position. A double test feature is employed in the selection of an idle position which is essentially that used in the subscribers' panel link circuit for hunting a district selector and sender.

When the trunk and a position are both found the "B" operator is cut through to the originating operator as described above. Meanwhile, the link advances and starts hunting for an idle sender. The double test relay in conjunction with other relays in the link, functions to drive the sender selector over the sender multiple to find and test an idle sender "hunt" terminal, similar to the method described above for selecting an idle

position. As soon as a sender is found, the link functions to close through three leads from the position to the sender connecting the key set on the position to the registration relays in the sender. See Fig. 7.

When the sender has received complete information from the operators' keyset, it signals the link to release the position circuit and to cut the fundamental tip and ring through to the incoming selector. When the incoming selector is in a position to proceed with incoming selections, the link is advanced in preparation for incoming and final selections.

Upon the completion of final units selections the incoming selector sends reverse battery back to the sender which in turn advances the link into its "down drive" position. The trunk finder is then returned to normal. The sender selector remains on the sender terminals just engaged unless they are within the top 20 terminals of the multiple in which case the link functions to return the sender selector to normal before advancing to the "awaiting assignment" position.

Link Allotment

The link allotment arrangement is similar in some respects to that employed in the subscribers' panel link circuit. After a call is served the link advances into its "awaiting assignment" position, 9 or 18. Links in the "awaiting assignment" position are allotted in order by means of a chain circuit in the links. When allotted the link is advanced into the "awaiting call" position, 1 or 10.

Figure 6 is a simplified drawing illustrating this arrangement. Assume for example the link of Figure C to be in the "awaiting call" position. When a call is originated on this link it advances into position 3 on finding the trunk, which completes a path from ground on the Q cam of the last link in the subgroup through like cams of intervening links over the "SA" lead to the first link of the subgroup and then back over the "S" lead to the link just picked by a call. From the "S" lead the ground is then carried through the "R" cam and over the "AS" lead to operate the "TF" relay of the next succeeding link in the "awaiting assignment" position. The operating path of the "TF" relay is from the "AS" lead through cams "U" and

"V" to the "F" lead. The operation of the "TF" relay advances the link into the "awaiting call" position.

When the last link in the subgroup is allotted, the next link to be moved to the "awaiting call" position will be the first link of the subgroup or if that is still busy serving a call, to the next link found in the "awaiting assignment" position.

Abandoned Call

If the originating operator should abandon the trunk before the trunk finder selector finds it, the trunk finder will be driven to the top of the trunk finder bank (telltale). Here the selector up-drive is released and the link circuit advances to the "sender hunt" position where an idle sender is selected. The link then advances to the "down drive" position where the trunk finder and sender selectors are returned to normal.

Should the call be abandoned after the trunk has been found but prior to the start of the fundamental selections the link will continue to advance and select an idle "B" operator if one has not already been selected. The "B" operator, however, is freed immediately she is found and the link advances to select an idle sender. As soon as a sender is found, the link sequence switch is driven into the "down drive" position where the link is restored to normal.

If the call be abandoned during fundamental selections, the incoming or final selector will complete the selections begun and then move into the "reverse battery" position, where the sender dismisses the link as described above.

Link Circuit Automatic Release Feature

In case the link remains in certain of its positions too long due to improper functioning of the circuits, the automatic release feature attempts to release the circuits. This feature is so arranged that the "B" operator will be released immediately and a reorder signal sent back by the link to the originating operator until she pulls down her cord, at which time the incoming selector, the sender, and the link will release.

The various positions of the link sequence switch and time interval

in which the automatic release feature functions when effective are as follows:

	<u>Link Release</u>
Position 1 or 10 - Awaiting Call	Not Effective
Position 2 or 11 - Trunk and Position Hunt	15 to 30 Sec.
Position 3 or 12 - Position Hunt	30 to 60 "
Position 4 or 13 - Local Relay Operation	15 to 30 "
Position 5 or 14 - Sender Hunt	15 to 30 "
Position 6 or 15 - Registration in Sender	30 to 60 "
Position 7 or 16 - Selections	15 to 30 "
Position 8 or 17 - Down Drive	15 to 30 "
Position 9 or 18 - Awaiting Assignment	Not Effective

"B" Switchboard Link Start Circuit Time Alarm And Start Lead Cutoff Jacks

An alarm is provided together with an automatic throw over feature in connection with the trip-and-start circuit. If the trip-and-start circuit attempts to start a link and the link does not free the start circuit within 5 to 12 seconds, the call is automatically transferred to the other subgroup and a link in that subgroup is started. Subsequent calls in the subgroup in trouble may or may not be shifted back to their proper subgroup depending on the nature of the trouble. The alarm, however, is locked in under control of a key located on the link frame. An audible alarm is sounded, a lamp on the frame is lighted, the aisle pilot and a pilot on the floor alarm board are lighted.

In addition to the regular start circuit alarm, an alarm is provided for the common lead from the trunks to the start circuit in order to indicate grounds on the common lead or failure of the start circuit relay contacts. This alarm is effective if the trouble persists for more than from 15 to 30 seconds. When this alarm comes in, a lamp on the frame is lighted in addition to the aisle pilot and a pilot on the floor alarm board. Before being connected to the common start lead, the start leads from the incoming selectors are connected together in groups of ten and carried through cutoff jacks, located on the "B" sender and position test frame. Thus, in case of a ground on the start lead in some incoming selector a make busy plug can be inserted in one start lead jack after another until the group of ten selectors involved is isolated. These particular incoming selectors can then be taken out of service and the trouble cleared without blocking service in the entire group.

Make-Busy Features

The usual means for making the incoming and final selector circuits busy are provided. The incoming selectors are made busy at the outgoing end and the final selectors are made busy by means of jacks and plugs at the final selector frames.

The "B" switchboard links are made busy by inserting a make-busy plug in a make-busy jack at the link frame, there being one jack for each link circuit. If a make-busy plug is inserted in a link make-busy jack during the process of setting up a connection, it does not interfere with the call. When the connection is completed, the link sequence switch advances to the out-of-service position and remains there until the plug is removed.

A make-busy jack is provided for each subgroup of "B" switchboard links and is associated with the start circuit. When a make-busy plug is inserted in one of these jacks, calls over trunks in that subgroup are routed through the other subgroup of links. The circuit is arranged so that in case make-busy plugs are inserted in both make-busy jacks of a group, neither one is effective.

A make-busy jack is provided for each "B" switchboard sender for the purpose of making the senders busy. These jacks are mounted on the "B" switchboard sender and position test frame

"B" Switchboard Link Time Alarm and Holding Jack

In case the link circuit remains in any of its positions other than the awaiting assignment or awaiting call positions, more than 20 seconds after the release feature, or the operation of the position disconnect key, an alarm is given. When the connection is released by the originating operator the incoming selector, the final selector, the link and sender restore to normal if possible and the alarm is retired. However, in order to provide means for the maintenance force to hold the links for the purpose of tracing trouble, and to indicate as nearly as possible where the trouble occurred, a holding jack per link is provided. When a make busy plug is inserted in one of these jacks, the operation of the time alarm feature or the operation of the position disconnect key causes the position to be freed and

the reorder signal to be sent back to the originating operator but when the originating operator releases the connection, the link and sender are prevented from restoring to normal, being held as nearly as possible in the position in which the trouble occurred. The trunk finder remains opposite the terminal of the incoming selector involved in the call. The incoming and final selectors are restored to normal and can then be used for subsequent calls.

The alarm circuit operates an audible alarm and lights the aisle pilot and a pilot on the floor alarm board. A lamp individual to the link and located on the link frame lights as soon as the release feature functions.

Motor Stop Alarm and Transfer

A "B" switchboard link motor stop alarm is provided which is similar to the alarms for other duplex motors. However, if a link motor stops, the circuit is arranged to transfer calls to the links on the side of the frame on which the motor is running.

The Link Frame

The "B" switchboard link frame is similar in design to the subscribers' link frame except that an additional relay bay is furnished at each end. The frame, which is 8' 2-5/8" in length, is designed to accommodate two link groups each consisting of 14 links and each serving a maximum 120 trunks. Each link consists of a panel-type sender selector and trunk finder and a 206-type selector for the position selector. See Fig. 5.

The links of each group are divided equally between the front and rear of the frame. Of the seven links of a group on the front, four are in the "A" subgroup and three in the "B"; and on the rear three are in the "A" subgroup and four in the "B". As on the 28-28 line finder frame, the start circuit equipment for the even numbered group is located on the front and for the odd numbered group on the rear. The apparatus for this circuit is mounted above the sequence switches.

The sender selectors are located in selector positions 9-22 and 39-52. As these selectors extend only half way up the frame, space is available on the trunk finder bank for reversing the multiple and for the trip

magnets. The trunk finders occupy selector positions 1-8, 23-28, 31-38 and 52-58. One test selector is required for group of senders. This selector is located in selector position No. 29 on the frame which has the senders of the group arranged in numerical order.

Two 100 terminal multiple banks are required for the sender selectors. These banks are the same as the corresponding banks used on the subscribers' link frame. If so specified, the sender multiple banks can be furnished with a 30-30 or a 40-20 split.

The sender cables for the first sender group are terminated to the outer end of the multiple banks on the first link frame. Where a second sender group is required, the cables are terminated near the middle of the multiple. This permits rearrangement of the sender grouping with minimum recabbling.

The senders are multiplied between the frames by means of a hand-made local cable. As on the subscribers' link frame, the lower 80 terminals of the sender selector banks are multiplied with a latin square slip, and the top 20 terminals with a rotating slip. Eighty per cent of the senders are always connected to the lower portion of the bank and the remaining senders to the upper portion.

Two 60 terminal trunk finder banks are located above the sender selector commutators. These banks, which are split in the middle and have a reversal in each half, are similar in design to a 28-28 line finder bank. Each half of a bank accommodates 60 trunks or a total of 240 per frame. Trip magnets are provided to select the proper bank.

The incoming selectors are cabled directly to the trunk finder bank. In order to equalize hunting time and to insure any group of trunks being equally represented in both the A and B subgroups, the odd numbered selectors of an incoming frame are cabled to the lower 30 terminals of each bank and the even numbered selectors to the upper 30 terminals. Since there is a reversal in each half of the trunk finder bank, the even numbered selectors have first choice to the A subgroup of links and the odd numbered selectors have first choice to the B subgroup of links. The group and sub-

group numbers are always assigned left to right facing the front of the frame.

The position selector, which is a 206-type selector, is located on a removable unit above the relays and sequence switches. The banks of the 14 position selectors on the same side of a link frame are multiplied together without slip and wired to a terminal strip mounted on the unit. The terminal strips on the front and rear sides of the link frames are then multiplied together by means of switchboard cable with a latin square slip between frames, so as to form a continuous multiple.

The cables from the switchboard positions are terminated on terminal strips located at the end of one or more lineups of link frames. From this point, switchboard cable is used to connect to the nearest position selector terminal strip described above. Where more than 20 positions are required, grading is resorted. In such cases, the individual positions are cabled from the grouping terminal strips to those position selector terminal strips where the subgrouping occurs and there connected to the proper terminals. The multiple cable leads between the frames are, of course, not connected for these positions.

The drive used on this frame has different roll speeds from those used on selector frames, and therefore, is not adapted to be connected to motors through the incoming frame drives.

It is considered standard to furnish a minimum of two frames each equipped with one link group for any installation. This requirement insures service to the subscriber should it be necessary to remove a frame temporarily because of drive or bank failure. Unless otherwise specified, the two trunk finder banks and all of the position finder banks on a frame are always furnished. The start and trip circuits are equipped as required. The frame is always completely wired for the two link groups.

Sender Circuit

The "B" senders are designed with no sequence switch or other power drive apparatus, all switching being accomplished by means of relays. This allows the sender to be mounted without regard to the possibilities of motor or drive failure.

The seizure of a sender was described above. The operation of registering the number in the sender is essentially as follows: See Fig. 7.

After the sender is made busy by the link, a ground from the link circuit is placed on the "SC" lead which operates the off-normal "ON" relay in the sender. This relay remains operated until the sender is released. The operation of the "ON" relay removes the 270-ohm battery from the hunt "H" terminal and places the off-normal ground on the sender circuit.

When the link cuts the "K1", "K2" and "K3" leads through to the sender, a battery from the position circuit is connected to the "FT" and "FR" leads to operate the "K1", "K2" and "K3" relays in series with the "U4" and "U1" register relays. The operation of the "K1" and "K2" relays together causes the "RR" relay to operate, whose function it is to operate all the register transfer relays, thus preparing the sender for registration. The register transfer relays lock to the off-normal ground. The "U4" and "U1" register relays release when the "RR" relay operates.

The position circuit then removes the battery from the "FT" and "FR" leads releasing the "K1", "K2" and "RR" relays. At this point an indication is given the "B" operator that the sender is attached and ready for registration.

The "B" operator on depressing the numerical keys connects either high or low resistance battery to leads "K1", "K2" or "K3". This is carried through the link circuit to the "FT", "FR" or "K" leads of the sender respectively. The "FT" lead is traced through the winding of the "K1" and "K3" relays, through the make contacts of the register transfer relays to the "TH4" and "TH1" register relays to ground. The "FR" lead in a like manner is traced to the "TH4" and "TH1" relays except that it passes through the "K2" relay instead of the "K1" relay. The "K" lead, however, is traced through the "K3" relay and thence through the contacts of the register transfer relays to the "TH3" register relay. The "K1", "K2" and "K3" relays operate on either high or low resistance battery while the register relays operate in accordance with the table shown on the drawing. The operation of the "K1" relay has no function to perform. However, each time the "K2" relay operates,

ground through a back contact of the "RR" relay and make contacts of the register transfer relays operate the "TH2" register relay. The "K3" relay operates upon the depression of a key to shunt down the "TRA" transfer relay, and releases when the key comes up, to drop the "TR1" transfer relay which switches the pulsing leads to the next set of register relays.

When the last digit is registered the sender signals the link which proceeds to release the position circuit at once. Fundamental selections do not differ materially from former "B" senders except that relays are used for switching instead of a sequence switch.

Sender Reset

Should the "B" operator depress the reset key, battery is connected from the position to the "FT" and "FR" leads to operate the "K1" and "K2" relays as shown in Fig. 7. The operation of these relays operates the "RR" relay which removes the off-normal ground from the register relays allowing them to restore to normal, and reoperates all the register transfer relays that may be released. The operator is then informed by the sender lamp that the sender is again ready for registrations.

Sender Frame

The "B" switchboard senders, as pointed out in Section 2.53 do not require any power driven apparatus. The frame is a single bay structure 2' 6-5/8" in length and arranged to mount five sender units. Each unit accommodates two senders.

The senders are normally furnished in units of two although a unit equipped with but one sender can be furnished if so specified. It should be noted, however, that doing this involved installing the relays of the second sender in the field at the time the additional sender is required.

Call Distributing "B" Switchboard Selectors

These incoming selectors are also arranged to return the overflow signal to the originating operator instead of the "B" switchboard operator as in the past when the selector encounters an overflow condition on trunk hunting, or when the selector is sent to telltale.

The call distributing "B" switchboard incoming selector circuits

Course A-132
Chapter XVI - A

for operation from manual local, and manual tandem offices, have been designed for conversion to operation from a panel office, mounting the various types of incoming selectors.

Universal local cables are furnished to permit the following conversions to be made.

1. Manual local to panel local.
2. Manual local to panel tandem (See Note 1).
3. Key indicator local to panel local.
4. Key indicator local to panel tandem (See Notes 1 and 2).
5. Manual tandem to panel tandem (See Note 1).
6. Panel local to panel tandem (See Notes 1 and 2).

Note 1: Any of the tandem circuits may be converted from 24 to 48 volts talking battery.

Note 2: For four-party semi-selective offices, the panel tandem circuits are mounted on 9' 6-5/8" frames, whereas the K.I. local and panel local circuits require only a 9' 1-5/8" frame.

As mentioned previously in this chapter, each link group serving 120 incoming selectors is divided into A and B subgroups of 60 selectors. Thirty of the selectors in the A subgroup together with a similar number of the B subgroup are terminated on each bank. The start leads for these 30 trunks are again subdivided and carried through cutoff jacks, so that each jack controls the start lead for 10 trunks. Likewise, at the incoming frames, the 60 selectors on a frame are divided into six groups, each containing 10 consecutive selectors on a side. It is necessary to keep this arrangement in mind when assigning selectors to the link frames in order that the start and hunt leads in the selector circuits will be connected to the associated link group. For cases where it is necessary to assign less than 120 selectors to a link group, the remaining selectors of a group of 10 if any should not be used for "B" switchboard operation. For example, should 115 selectors per link group be sufficient, 11 complete incoming groups of 10 selectors each plus one partial incoming group of 5 selectors would be required. The five selectors remaining in the last group would either not be equipped or would be arranged for other than "B" switchboard operation.

Reorder and Permanent Signal Trunks

In case the "B" operator fails to remember the number passed by the originating operator or in case no number is passed, the operator will play up the reorder number. This will route the incoming trunk to a group of final terminals on which are the reorder and permanent signal trunks. Each of these trunks is arranged to give a reorder signal to the originating operator. An alarm is given after an interval from 15 to 30 seconds, in case the originating operator fails to disconnect or in case of a permanent signal.

Coin Control Circuit

Coin control equipment is provided for call distributing "B" incoming selectors from long distance. The collect and refund keys of this circuit are mounted on the face equipment of the D.S. "A" switchboard. The long distance operator is provided with a call circuit to the D.S. "A" operator so that she may order the operation of these keys as required.

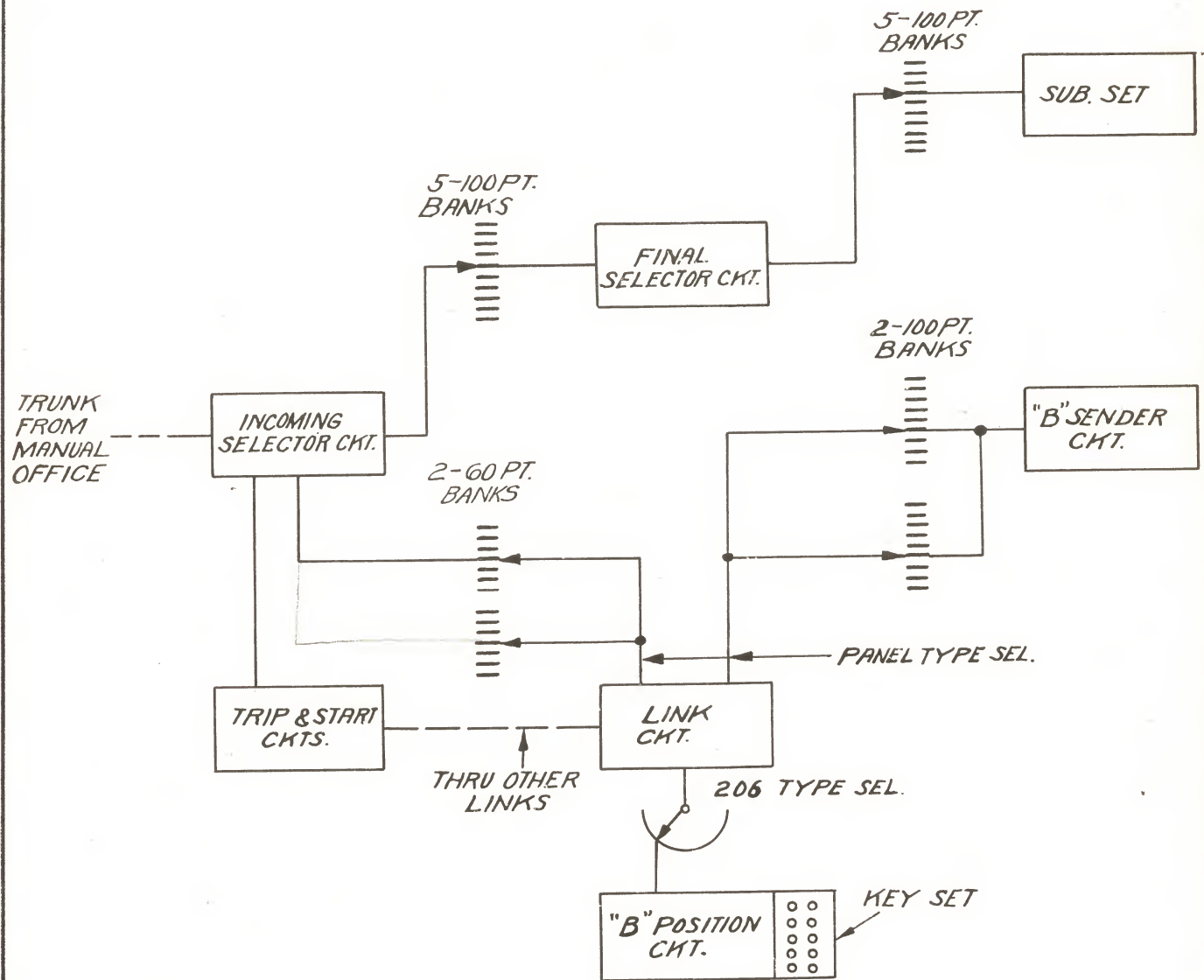

SCHEMATIC ARRANGEMENT OF
 CALL DISTRIBUTING "B" SWITCHBOARD
 FIG. 1

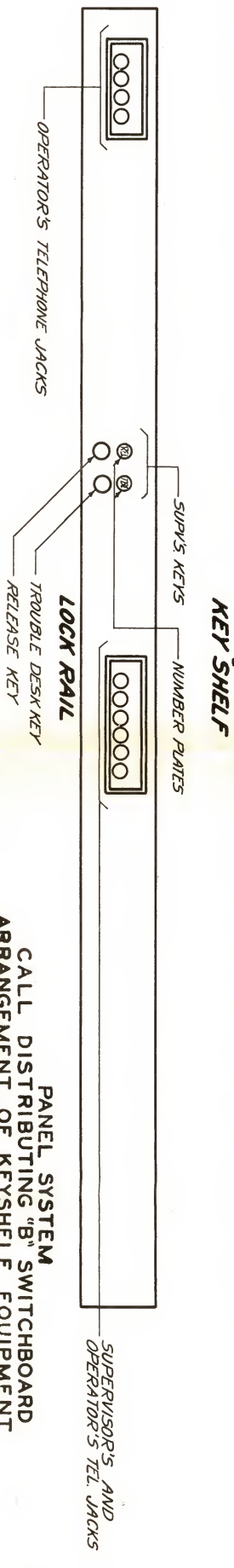
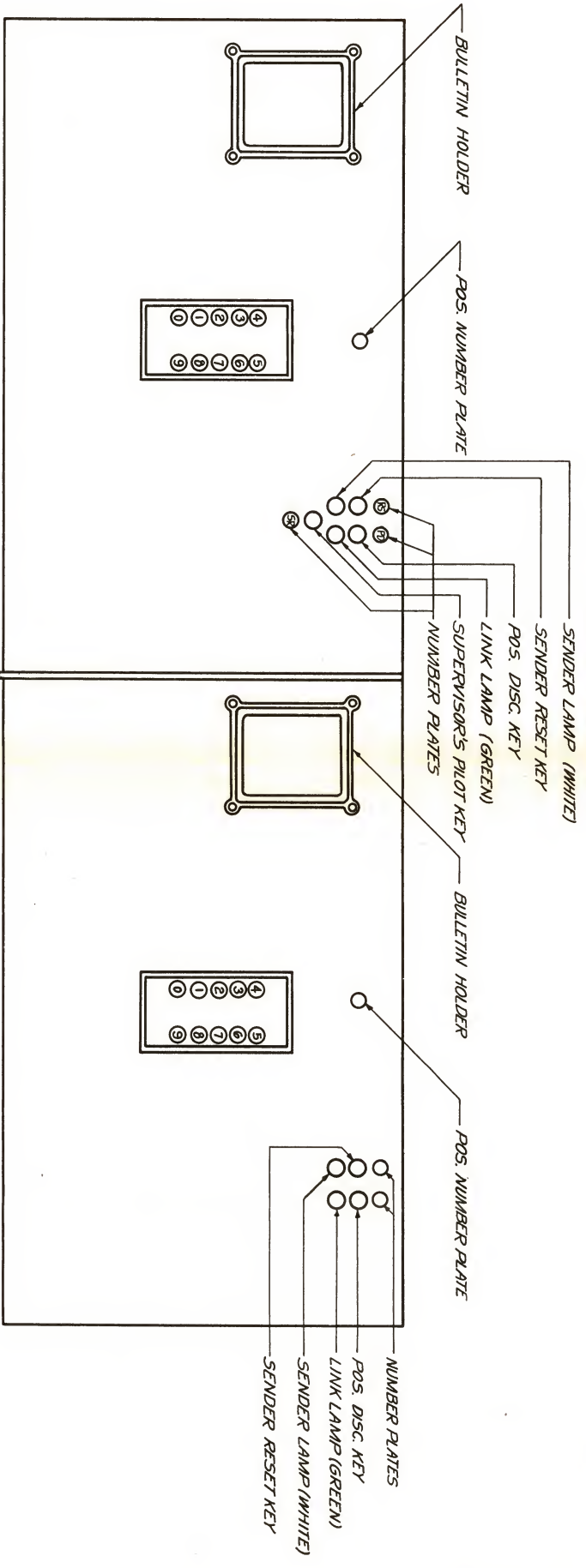
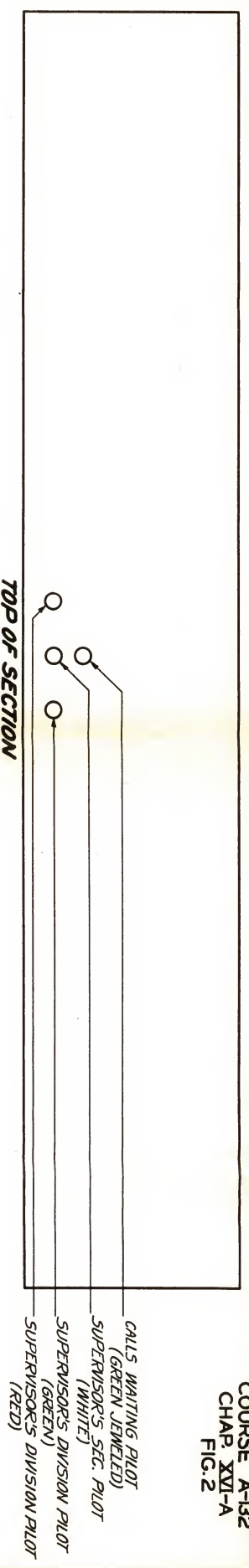

PANEL SYSTEM
 CALL DISTRIBUTING "B" SWITCHBOARD
 ARRANGEMENT OF KEYSHELF EQUIPMENT
 FIG. 2

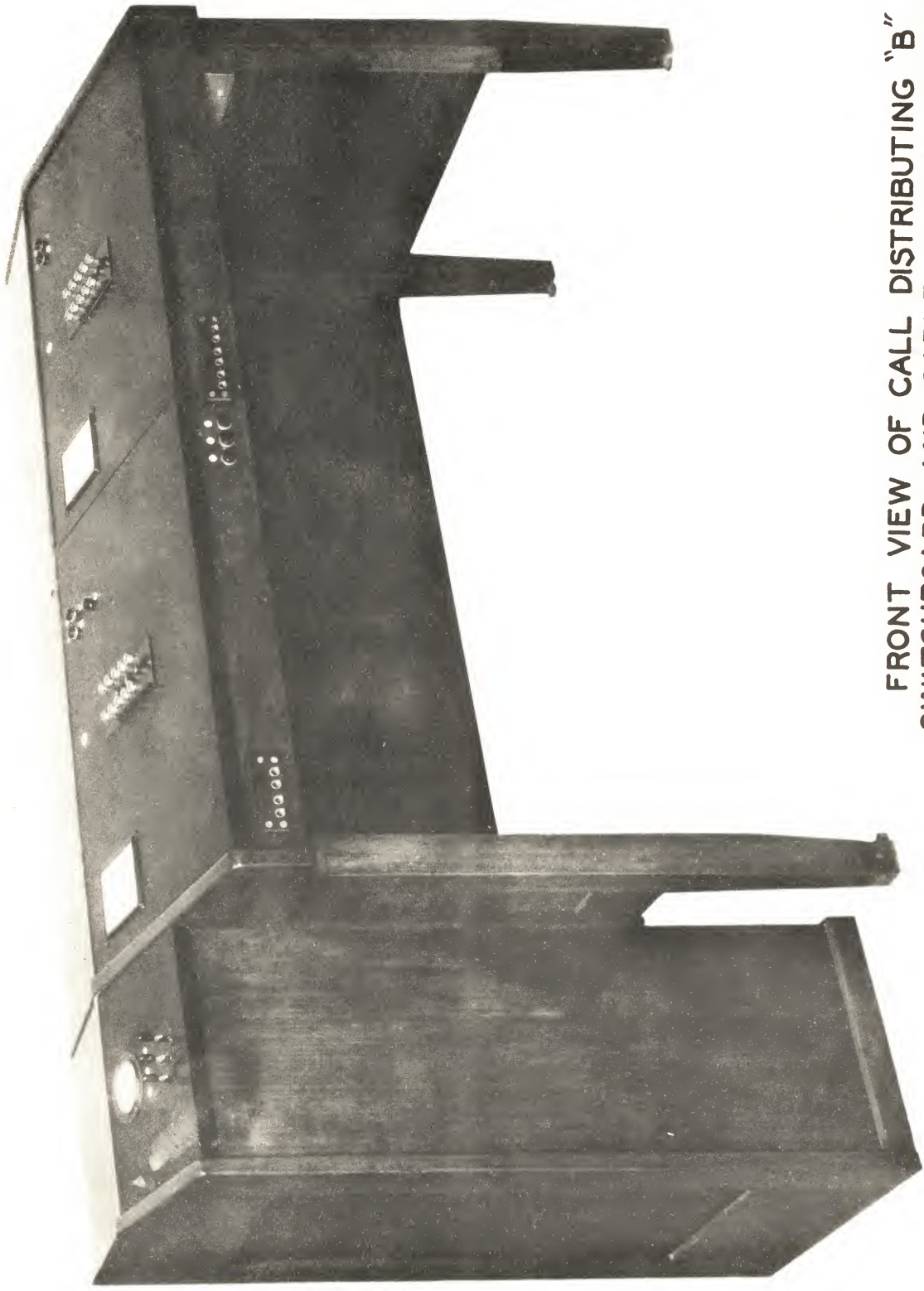

FRONT VIEW OF CALL DISTRIBUTING "B"
SWITCHBOARD AND CABLE TURNING SECTION
FIG. 3

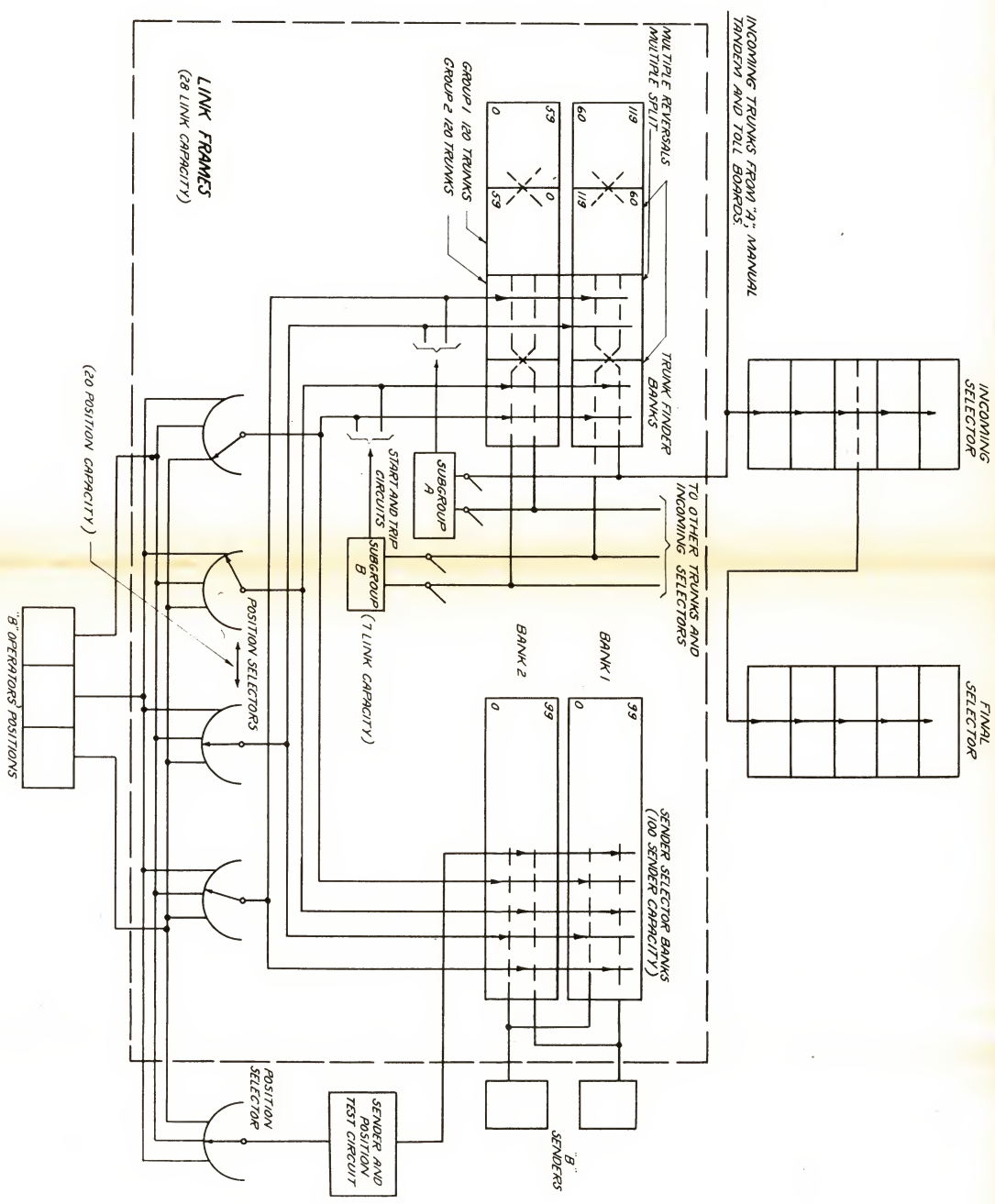

PANEL SYSTEM
 CALL DISTRIBUTING B SWITCHBOARD
 SCHEMATIC ARRANGEMENT
 FIG. 4

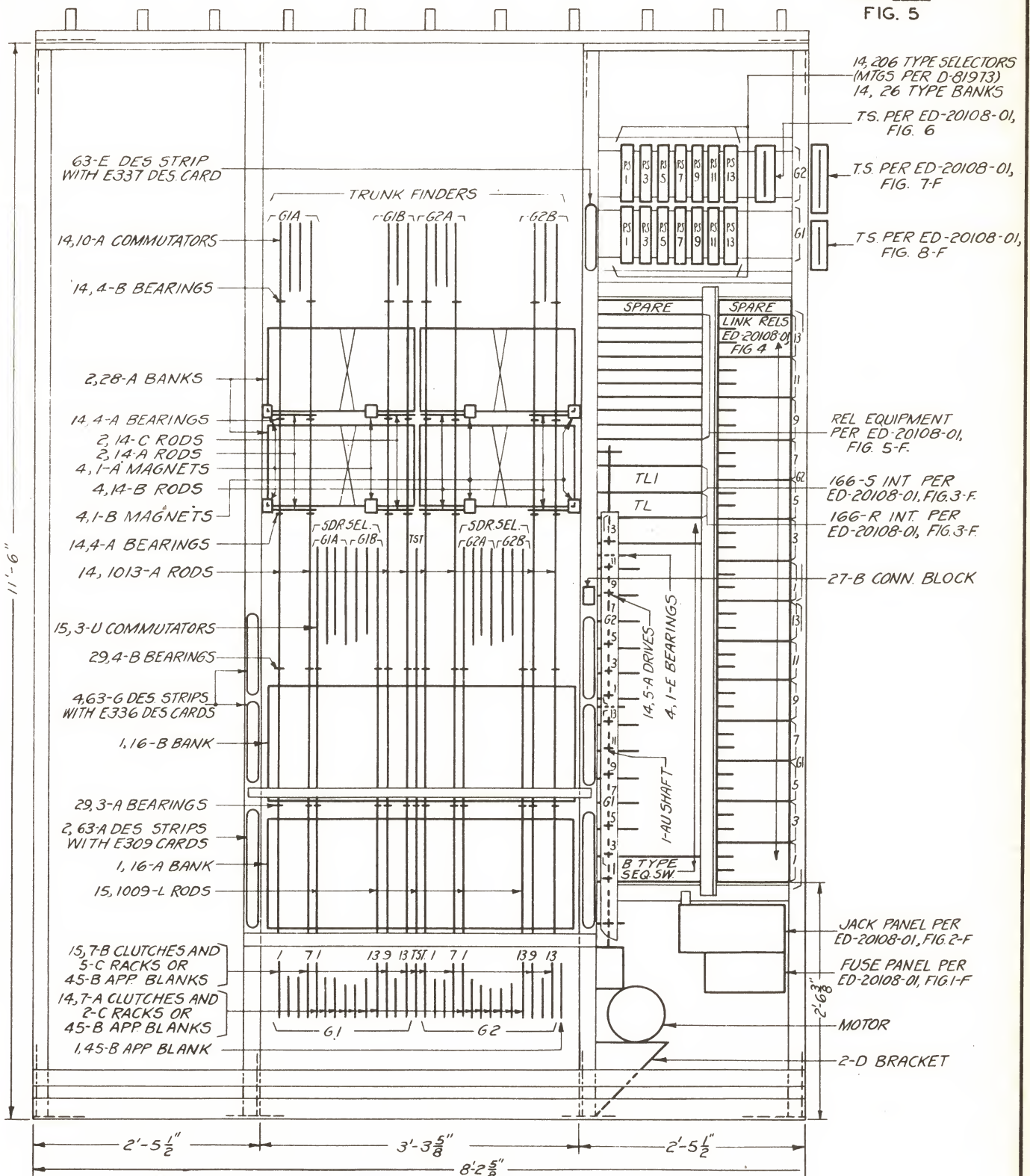

63-E DES STRIP WITH E337 DES CARD

14, 10-A COMMUTATORS

14, 4-B BEARINGS

2, 28-A BANKS

14, 4-A BEARINGS

2, 14-C RODS

2, 14-A RODS

4, 1-A MAGNETS

4, 14-B RODS

4, 1-B MAGNETS

14, 4-A BEARINGS

14, 1013-A RODS

15, 3-U COMMUTATORS

29, 4-B BEARINGS

4, 63-G DES STRIPS WITH E336 DES CARDS

1, 16-B BANK

29, 3-A BEARINGS

2, 63-A DES STRIPS WITH E309 CARDS

1, 16-A BANK

15, 1009-L RODS

15, 7-B CLUTCHES AND 5-C RACKS OR 45-B APP BLANKS

14, 7-A CLUTCHES AND 2-C RACKS OR 45-B APP BLANKS

1, 45-B APP BLANK

TRUNK FINDERS

G1A G1B G2A G2B

SDR SEL. G1A G1B TST G2A G2B

PS 1 PS 3 PS 5 PS 7 PS 9 PS 11 PS 13
 PS 1 PS 3 PS 5 PS 7 PS 9 PS 11 PS 13

SPARE

SPARE LINK RELS ED-20108-01 FIG 4

TL1

TL

14, 5-A DRIVES

4, 1-E BEARINGS

1-AU SHAFT

B TYPE SEQ SW

14, 206 TYPE SELECTORS (M765 PER D-81973)
 14, 26 TYPE BANKS

T.S. PER ED-20108-01, FIG. 6

T.S. PER ED-20108-01, FIG. 7-F

T.S. PER ED-20108-01, FIG. 8-F

REL EQUIPMENT PER ED-20108-01, FIG. 5-F.

166-S INT PER ED-20108-01, FIG. 3-F

166-R INT PER ED-20108-01, FIG. 3-F

27-B CONN. BLOCK

JACK PANEL PER ED-20108-01, FIG. 2-F

FUSE PANEL PER ED-20108-01, FIG. 1-F

MOTOR

2-D BRACKET

FRONT VIEW

REAR VIEW SAME EXCEPT NUMBERED 2 TO 14 INSTEAD OF 1 TO 13.

EQUIPMENT FOR CALL DISTRIBUTING "B" LINK FRAME
 FIG. 5

REAR OF FRAME

FRONT OF FRAME

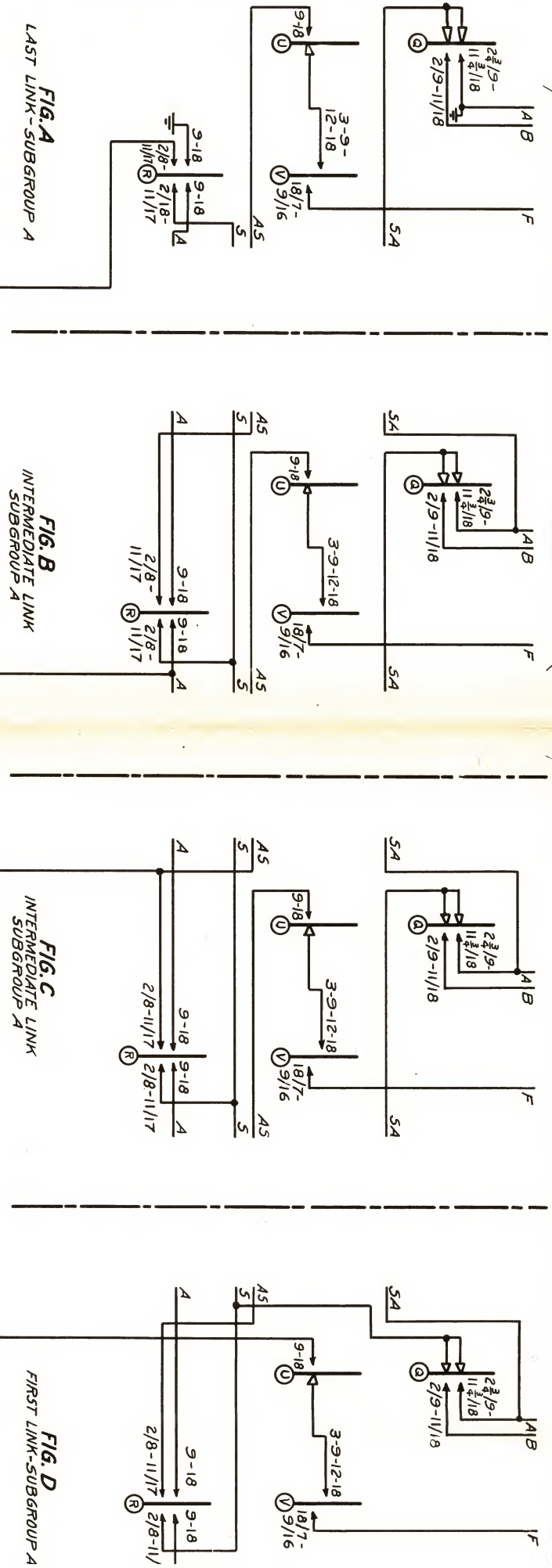

FIG. A
LAST LINK-SUBGROUP A

FIG. B
INTERMEDIATE LINK
SUBGROUP A

FIG. C
INTERMEDIATE LINK
SUBGROUP A

FIG. D
FIRST LINK-SUBGROUP A

LINK SEQ. SW. POSITIONS
 1-10 AMTG. CALL
 2/8-11/17 CALL IN PROGRESS
 9-18 AMTG. ALLOTMENT

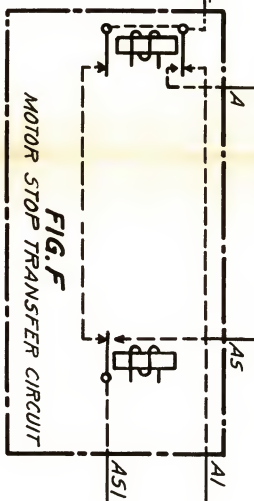
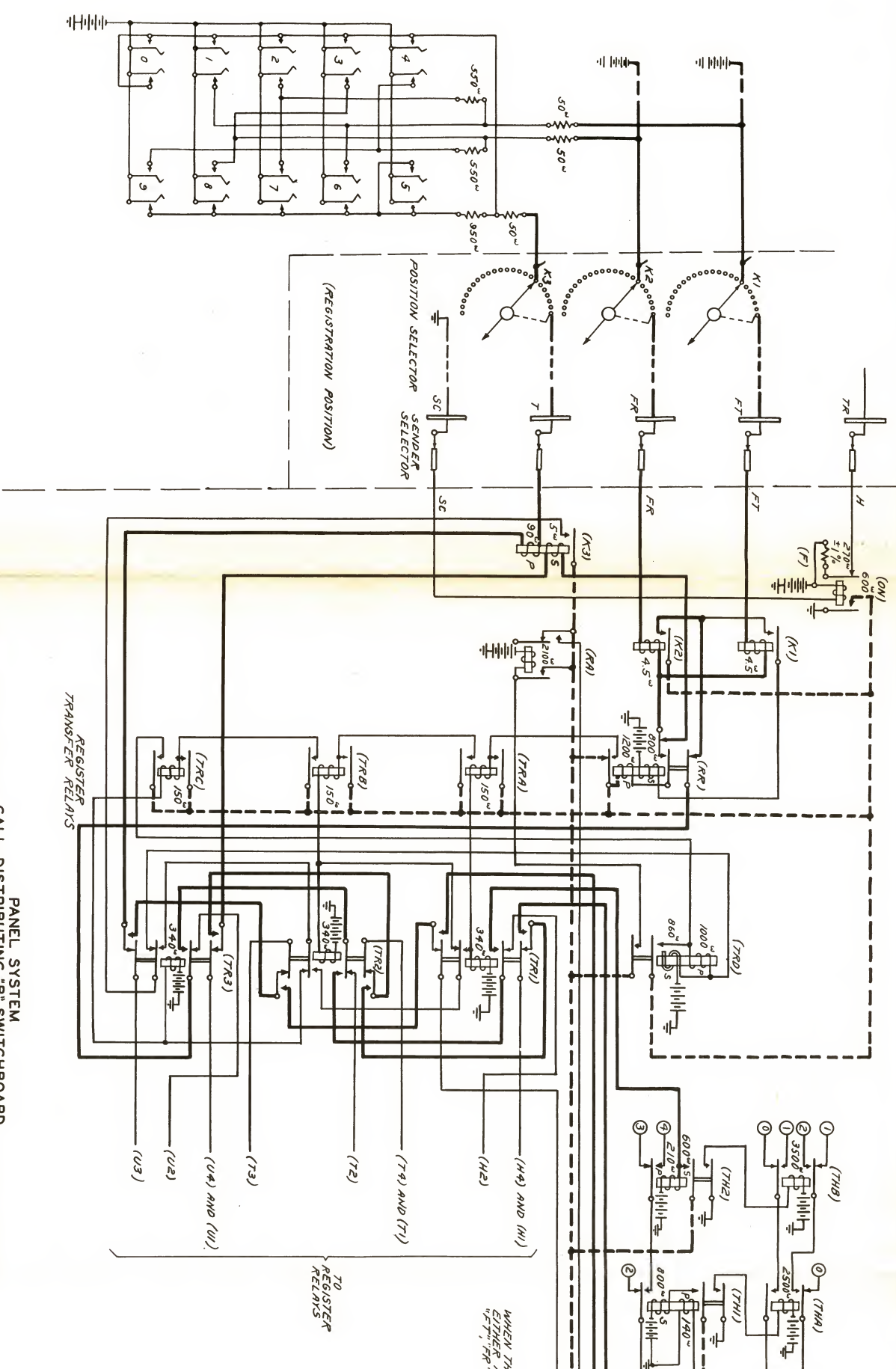

FIG. F
MOTOR STOP TRANSFER CIRCUIT

PANEL SYSTEM
 CALL DISTRIBUTING "B" SWITCHBOARD
 SIMPLIFIED CIRCUIT SHOWING LINK ALLOTMENT ARRANGEMENT
 FIG. 6



PANEL SYSTEM
 CALL DISTRIBUTING "B" SWITCHBOARD
 SIMPLIFIED CIRCUIT SHOWING METHOD OF REGISTRATION IN THE SENDER
 FIG. 7

CHAPTER XVII

"KEY INDICATOR" AND "DIALING A" METHODS OF COMPLETING CALLS FROM
MANUAL OFFICE TO PANEL OFFICEKey-Indicator Method

Where a Manual office is to remain in service for a number of years and an appreciable percentage of the originating traffic at the "A" position is trunked to Panel offices, key-indicator equipment may be used in the Manual office, instead of providing Panel System cordless "B" switchboards in the Panel offices, as a means for completing Manual to Panel calls.

The equipment involved in completing a call from a Manual to a Panel office by the key-indicator method is shown in Figure 1. The "A" operator at the Manual office answers a subscriber in the usual way, but instead of passing the call to a trunk operator, she completes it herself without the aid of any other operator. Each "A" position keyshelf is equipped with numerical keys and the panel in front of her is equipped with a trunk indicator, consisting of a set of lamps for displaying the number of the assigned trunk. The method of operation is briefly that the "A" operator, having received the number from the calling subscriber, depresses the office key corresponding to the called office. This operation causes the allotter circuit to select an idle link circuit, which in turn connects the numerical keys at the operator's position with a sender, and with an idle trunk to the called office. Immediately upon depressing the office key, the "No Trunk" signal, located in the left end of the trunk indicator, will light, and as soon as the link circuit has picked out an idle trunk, this signal will be extinguished and the number of the trunk will be displayed on the trunk indicator. If no trunk is available, the "No Trunk" signal will remain lighted, either until the link is released or until a trunk becomes available. A sender lamp, which is located in the panel immediately in the rear of the numerical keys, will also light when the office key is depressed and will remain lighted until an idle sender has been selected. Immediately after the sender lamp has been extinguished the operator depresses the numerical keys corresponding to the thousands, hundreds, tens and units digits of the number called. The keys must be depressed in the sequence given above, but may be operated as rapidly as possible, so long as only one key is depressed at a time.

The called number is thus registered in the sender circuit. The operator then inserts the plug of the calling cord into a multiple jack of the assigned trunk, the number of which has, until this time, been displayed on the trunk indicator. This retires the trunk number displayed, and releases the operator's position from the connection. The trunk connects to a key indicator incoming selector circuit in the Panel office and the key indicator sender in the Manual office controls incoming and final selections. When the connection is established the sender returns to normal. Incoming selectors from key indicator offices are similar to incomings from Panel offices except that they are arranged for manual (high-low) supervision instead of for "reverse battery" supervision, and are arranged to flash the calling cord supervisory lamp in the Manual office on overflow or tell-tale condition. In case the called line is not available, due to its being busy, out of order, etc., the call is handled the same as a call from a Panel to a Panel station.

When key-indicator equipment is provided, the connections between the subscriber's answering jacks and the outgoing trunk jacks are set up by means of regular subscribers' cord circuits. The function of the key-indicator equipment is merely to establish the connection in the Panel office and consequently no changes are required in the present position equipment. It is necessary, however, to add the following apparatus in each position:

- A trunk indicator
- A numerical key-set
- A sender lamp
- 1 - office key for each full mechanical office

The trunk indicator is located in the answering jack space in the switchboard, and is wired to the position relay equipment, located on the key indicator frame, by means of switchboard cable. The numerical key-set and sender lamp are wired to terminals located in the rear of each position. The wiring of the regular call circuit keys is used for the office keys. The numerical key-set, sender lamp and office key wiring is extended to the relay equipment on a key-indicator frame by means of switchboard cable.

There is one position circuit for each "A" position equipped for key indicator operation, the apparatus for ten position circuits being mounted on one

"position relay frame". There is at least one allotter circuit, one group of link circuits, and one group of trunks for each panel office to which it is necessary to complete calls. Each allotter circuit serves a maximum of 100 positions and can allot one out of a maximum of 21 link circuits. When the office key is depressed at any one of these positions, one of the idle link circuits is allotted by the allotter circuit. The apparatus for either 2, 4, or 6 allotter circuits is mounted on each "allotter and miscellaneous frames", one allotter circuit consisting of a regular and an emergency allotter. Outgoing trunk relays are also mounted on this frame. An allotter has a starting circuit for every twenty positions of "A" board, only one of which can be in use at one time. Each link circuit can select any one of a maximum of 160 trunks in a group, select any one of a maximum of 21 senders, find the position at which the office key has been depressed, and connect the selected sender to the numerical keys at this position and to the selected trunk. The link circuit is composed of a number of relays and three or more 200 type selectors; one 200 type selector is used as a sender selector, one is used as a position finder for each group of 20 positions, and one is used as a trunk finder for each sub-group of 20 trunks there being one additional 200 type selector when there is more than 20 trunks to distribute the calls over the various sub-groups. The apparatus for ten link circuits is mounted on a link frame together with a set of battery and position jacks. A sender circuit consists essentially of register relays, counting relays and fundamental circuit relays, the apparatus for ten senders being mounted on each sender frame.

The economy secured through the use of the key-indicator method is due to the elimination of cordless "B" operators and equipment at Panel offices. There is also a saving in operating expense due to the speed with which calls can be handled under this arrangement and the chances for error or less than those which exist when numbers are "passed" between two operators. The disadvantage lies in the fact that existing Manual offices must be equipped with a rather large amount of apparatus, entailing a considerable amount of labor and inconvenience during installation. This equipment consists principally of relays and 200 type selectors and does not include any power driven apparatus. Key indicator apparatus is also used at Manual Toll boards for connecting Panel subscribers' lines with a toll line on both incoming and outgoing toll calls.

"A" Positions in Manual Offices equipped with Dials.

When, in an area having both Panel and Manual offices, it is uneconomical to provide key indicator equipment in the Manual offices, and when the traffic is not sufficient to warrant the installation of a cordless "B" board in the Panel office, the "A" positions in the Manual offices are equipped with dials and dial keys. The "A" operator answers a call in the usual way and having received the subscriber's order tests the sleeve of the outgoing trunk jacks and inserts the plug of the calling cord in a jack associated with an idle trunk to the panel office desired. Operation of the dial key which is associated with this cord connects the dial to the selected trunk. The trunk terminates on a dialing incoming selector in the Panel office and as soon as the calling cord plug has been inserted in the outgoing trunk jack the incoming selector circuit selects and connects itself to an idle "incoming trunk sender" circuit. Operation of the dial registers the called number in this sender. Incoming and final selections are then controlled by the sender according to setting of the registers, the sender being released as soon as selections have been completed. This method is low in first cost and involves the addition of only a small amount of equipment in the Manual offices; but it has the disadvantage that the additional time required by the "A" operator, in dialing the called number, decreases the number of calls which each operator can handle in the busy hour to such an extent that additional positions and operators may be required.

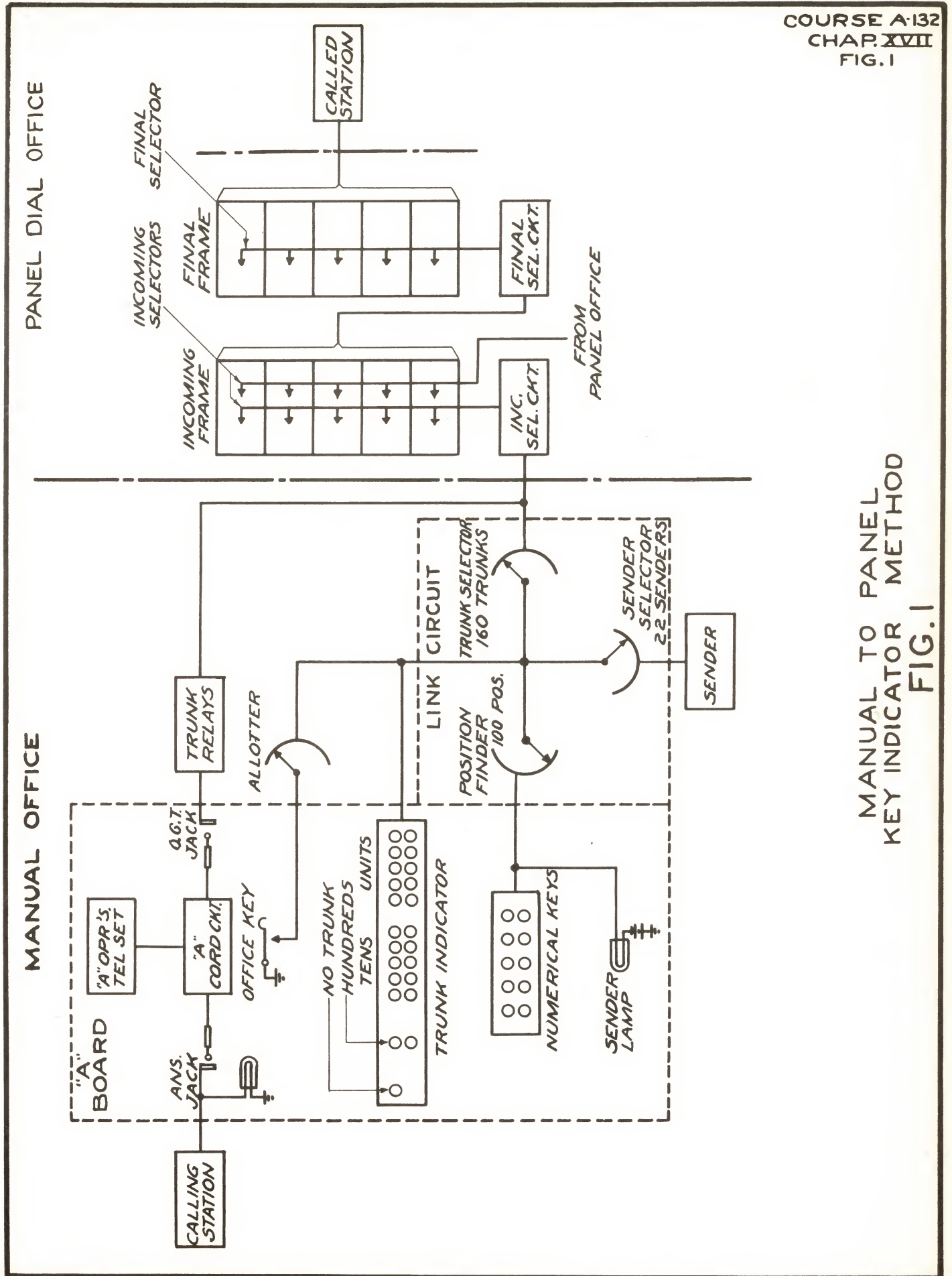

MANUAL TO PANEL
 KEY INDICATOR METHOD
 FIG. 1

CHAPTER XVIII"OPERATOR CLASS" CALLS

In addition to mechanical class and RCI class calls the subscribers in panel offices also make "Long Distance" calls, "Suburban" toll calls, calls to "Information" operator, calls to "Repair Clerk", and calls to the Telephone Company's commercial department, all of which come under the general heading "Operator Class" calls. Other operator class calls which are completed by the sender include "Restricted Zone" class calls on which the subscriber dials the office code and number instead of dialing 0, and calls which the sender routes to a "Sender Monitor" operator on account of incomplete dialing.

Long Distance Calls

In making a call which is completed through a "long distance" toll board the calling subscriber dials 211. Only the first two digits are necessary in a 2 digit area but for traffic reasons it is desirable to use the same code in both 2 and 3 digit areas. The operation of the panel equipment is the same as on a mechanical class call up to the point where a district or office selector has selected an idle recording trunk which terminates in an answering jack at the recording board, with the following exceptions: The class switch in the sender is set in the "operator" class position and the register control switch RC is advanced to terminal 9 as soon as the class switch has been set (since dialing has been completed). After making "trunk test" the sender advances to the talking selection position passing by the incoming and final selection positions. Talking selection is completed, the district being advanced to the proper talking position, after which the sender returns to normal. A ringing tone is transmitted to the calling subscriber after talking selection has been completed until the recording operator answers. The call is answered and a ticket is made out by the recording operator in the usual way.

In certain cases it is necessary that the recording operator know the class of line from which the call is being made, and, for this purpose, three groups of recording trunks are generally provided from the machine switching offices to the recording operator. One group is used only on calls from multi-slot prepayment coin box lines (it being necessary that the recording operator note on the ticket that a coin box switching trunk is required

by the outward toll operator in completing the call); a second group of trunks is provided for calls from "refused toll" lines; and a third group is provided for calls from all other classes of lines. The switching trunks over which the "outward" operators at the toll board complete the connection to the calling subscriber terminate on multiple jacks at the toll board and terminate either as cordless "B" incoming or key indicator incoming circuits in the panel office, depending upon which of the two methods is provided for completing these calls. These incoming circuits differ from those used on calls from local Manual offices only in respect to control of ringing. Incoming and final selections having been completed the incoming waits for operation of a ringing key, associated with the toll cord in the toll office, before ringing is started; and since the talking connection is established without advancing the incoming switch, the toll operator can again start ringing, if necessary, by reoperating the toll cord ringing key. Key indicator or cordless "B" incoming trunks are also used by the operators at "inward" positions of the toll board for completing calls, incoming over toll lines to subscribers in Panel offices. The trunk circuit and panel selector circuits, which are used on a call, are released when the toll operator disconnects.

Suburban Toll Calls

On toll calls other than those completed thru a long distance toll board, the subscriber in a panel office dials "0". Translation is made as soon as the "A" register in the sender has been advanced to terminal 0, and the trunk selected terminates at a special service position of the Panel system "A" switchboard. The operator at this position answers the call with a cord which is either a manual double-ended cord or a semi-mechanical single-ended cord, depending upon the type of "A" board which has been provided. When the position is equipped with manual double-ended cords, the call may be completed to Manual offices or Manual Tandem offices by the use of either call circuit or straightforward trunks. Calls to offices of all types are completed by inserting the plug of the calling cord in a jack which connects to a dialing district selector, the called number being dialed by the "A" operator and the connection completed as controlled by a regular subscriber's sender; when completed the connection is under control of the operator and the calling

subscriber, it being necessary for both to release the connection before the district selector returns to normal. When the position is equipped with the semi-mechanical single-ended type of cord, the called number is recorded in an "A" operator's sender circuit by the depression of the numerical recording keys located on the keyshelf, which correspond to the called number. The cord is part of a "semi-mechanical cord and district selector circuit" and the call is completed as controlled by the operator's sender. The equipment and the operations involved in completing a call at a special service position of the "A" board is considered in greater detail in the next chapter.

Since the method of handling a call at a special service position of the MS "A" board depends upon the class of line from which the call originates, it is necessary to provide separate groups of special service or "zero operator's" trunks for handling originating calls from those classes of lines involving different operating practices. One group of trunks is provided for flat rate or message rate lines entitled to unrestricted service within the maximum local area; a group is provided for flat rate and message rate lines entitled to service within a restricted local area (for every restricted local area there is a separate group of trunks); a group is provided for flat rate and message rate lines which are "refused-toll" service (if restricted local area service is rendered a group of refused-toll trunks is provided for the maximum local area, and an additional group is provided for each restricted local area); a group is provided for single slot coin box lines; a group is provided for single slot coin box refused-toll lines; and a group is provided for multi-slot coin box lines. In any one office it is not necessary to provide all of these groups of trunks because one office will not render service to all of these classes of lines.

Restricted Zone Class Calls

When a subscriber dials an office code and number which involves an extra charge the sender class switch is set in the "Restricted zone" class position and the call is routed to a special service (or AB) toll position of the Panel System "A" switchboard over a trunk in the same group as it would have been routed if the subscriber had dialed "0". The only difference between

the two calls is that the sender makes sure that dialing has been completed before it permits "trunk test" to be made on a restricted zone class call so that the dialing of the numerical digits will not break down the connection after the trunk has been selected.

Calls to Other 3 Digit Operators

When a Panel subscriber wishes to make a call and cannot find the name and number in the directory, the code 411 is dialed causing the calling subscriber's line to be connected to a trunk which terminates at an "Information" operator's position which is usually located at a centralized information desk, serving all offices in the area. When a subscriber wishes to report a telephone out-of-order, the code 611 is dialed causing the calling subscriber's line to be connected to a trunk which terminates at a "Repair clerk's position" which is located at a centralized "Repair clerk's desk" serving all the offices in the area. When the subscriber wishes to talk to someone in the Telephone Company's business office, the code 811 is dialed causing the calling subscribers lines to be connected to a trunk which terminates at a P.B.X. serving the commercial department. On each of these three kinds of calls the operations involved, in selecting an idle trunk to the proper designation, are the same as those on a call to "Long Distance" operator.

Calls Routed to Sender Monitor Operator

When a subscriber's line has been connected to a sender circuit and a "permanent signal" or "partial dial" condition results, the call is routed over a "permanent signal" trunk to a "sender monitor operator's" position as described in Chapter XIV. Sender monitoring equipment is located either at the Panel System "A" switchboard or at a "Trouble Desk", both of which are considered in subsequent chapters.

CHAPTER XIXPANEL SYSTEM "A" SWITCHBOARDPURPOSE

The services of an operator are required for handling certain classes of traffic in a Panel Office and to care for this traffic a "Panel System "A" Switchboard" is provided. The positions of this board may be classified according to the service rendered as intercepting, special service, subscribers' line, and sender monitoring positions. The latter will be considered in a following chapter.

TYPES

Panel System "A" Switchboards may be of two general types. The one employing manual dialing cords at the special service and subscribers positions and the other employing semi-mechanical cords at these positions. It is customary to refer to a Panel System "A" Switchboard as either a "Semi-Mechanical "A" Board" or a "Manual Dialing "A" Board" depending upon the type of cord equipment employed at the special service and subscribers positions. The positions of semi-mechanical "A" boards are all inclined slightly toward the operator to facilitate the operation of the keys at these positions which are equipped with semi-mechanical cord circuits. With this exception the positions of both manual dialing and semi-mechanical "A" boards are of the same general type as the "A" positions of a standard #1 board.

POSITIONS

Intercepting positions are provided for intercepting calls to unused codes, to unequipped groups of 500 lines for which there is no group of trunks from the incoming frames, to all classes of non-working lines, and to stations to which service is being intercepted on account of directory errors, temporary disconnections, non-payment of bills, or change of number. It is very essential that means be provided for bringing calls for unused codes or for non-working terminals to the attention of an operator; in either case a mistake has been made in dialing or the equipment has failed to operate properly. When an unused code is dialed the calling subscriber's line is connected by a

district or office selector to a trunk which terminates on an answering jack at one of the intercepting positions. In cases where the office is not fully equipped with 10,000 lines non-working terminals appear as blank lines on the final frames or as unequipped choices on the incoming frames. The blank final lines are cross-connected at the IDF to answering jacks at an intercepting position, a large number of these lines (usually 100) being connected to one jack. Unequipped choices on the incoming frames are multipled together and regular slip multiple cable is installed between each choice on all of the frames. A switchboard cable is then run from as many sets of terminals as are required on the top choice to the IDF and is there cross-connected to answering jacks in the "A" switchboard. When incoming service to a particular line number is to be intercepted on account of directory error, change of number, or temporary disconnection an answering jack at one of the intercepting positions is cross-connected at the IDF to the multiple terminals of this number on the final frames. Where outward service is denied on account of non-payment of bill the subscriber's line is cross-connected at the IDF to an answering jack at an intercepting position instead of to the line finder so that a call from this line will be answered by an intercepting operator. Calls incoming to this line are still completed thru the final multiple. (See Fig. 1, Chapter 4.)

Special service positions are provided for handling "AB" toll and "two-number" toll calls, information or assistance calls, complaint calls, subscribers reports of "cut-offs", and request from subscribers for verification of "don't answer" or "busy" reports. The operators at these positions are reached by dialing zero in which case the trunk is selected by a district or an office selector which terminates on an answering jack at a special service position. Similar trunks are used to complete extra charge or toll calls when the calling subscriber dials the office code and number instead of dialing "0".

At a manual dialing type "A" board the incoming calls are answered by inserting the plug of the answering cord in the answering jack; calls to points reached through the subscriber's district multiple may be completed by inserting the calling cord in one of the jacks which connect to an "A" position

"Dialing District Selector" circuits; calls to manual or manual tandem offices may be completed over call circuit, straightforward, or ringdown trunks, which connect to jacks in the outgoing trunk multiple; and calls to subscribers in the same office may be completed over call circuit or straightforward trunks to the Cordless "B" board, or over trunks to "Dialing Incoming Selector" circuits.

At a semi-mechanical type "A" board the incoming calls are answered by the use of single ended cords which are part of a "Semi-Mechanical Cord and District Selector" circuit; the called numbers are recorded in "A" sender circuits by the operation of recording keys which are mounted in the keyshelf of each position and the connections are completed under control of the "A" senders.

Subscribers' line positions may be provided for handling coin box lines and message rate party lines when the number of such lines is not sufficient to warrant handling them on a full mechanical basis. These positions are from an equipment viewpoint special service positions. It may be desirable to terminate the coin lines at one group of subscribers positions and to terminate the message rate party lines at another group of subscribers positions.

In all offices both intercepting and special service positions will be furnished at the Panel System "A" switchboard but subscribers line positions will not always be required. It is desirable to equip adjacent positions handling different classes of traffic with both kinds of cord equipment so that the operators at both positions can handle traffic of either class. In general positions arranged for "teamwork" operation are placed between intercepting and special service positions. The relative arrangement of the various classes of positions in the line-up of an "A" board is largely dependent upon the relative rates of growth of the various classes, the slower growing classes ordinarily being placed at the head of the board.

FACE EQUIPMENT

The assignment of face equipment at the "A" board varies widely according to the conditions of each installation but may be divided broadly

into the following classes which normally appear in the order given starting at the top of the piling block:

1. Holding Jacks
2. Outgoing trunk multiple
3. Answering jack equipment
4. Checking multiple.

At each position having semi-mechanical cords, holding jacks are required in order to permit "split cord" operation. If a cord which has been used to establish a connection is transferred to one of these jacks, the connection is held providing the operator is "listening-in" while transferring the cord.

The outgoing trunk multiple of the Panel System "A" switchboard is installed on a six-panel basis and the outgoing trunks are multiplied throughout the entire board even though the complete multiple is not required at all positions since the advantages of flexibility and uniformity out-weigh the additional cost. Outgoing trunks are provided on both manual dialing and semi-mechanical type "A" boards to chief operator's and assistant chief operator's desks, to supervisors, to power driven frames, to sender make busy frames, to routine test circuits, and to cordless "B" positions. Manual dialing type "A" boards are also provided with call circuits or straightforward trunks to manual and manual tandem offices, trunks to recording operator, trunks to "A" operators district selectors, and trunks to dialing incomings. Semi-mechanical type "A" boards are not equipped with trunks to "A" operators district selectors or to dialing incomings, but the semi-mechanical cords are part of "semi-mechanical cord and district selector" circuits thru which the semi-mechanical "A" operator reaches all points to which it is necessary to complete calls.

The lines and trunks terminating in answering jacks at the "A" board include intercepting and verifying trunks, blank incoming lines, blank code trunks from district and office frames, non-dial subscribers, trunks to special service operators from district and office multiples, supervisors lines, desk lines, and lines from sender monitors positions.

A special type of multiple called "Checking multiple" is provided within the reach of the operators at special service positions so that a check

can be made of the calling subscriber's number, on calls requiring the writing of a ticket. The checking multiple consists of a series of lugs mounted in strips in the same order as the jacks of regular subscriber's multiple in the manual system and these lugs are connected to the correspondingly numbered subscribers line sleeve terminals. The checking multiple is arranged in groups of 100 lines as shown on figure 4. In order to facilitate selection of any particular lug the test strip is provided with white "spotting" between each five lugs and a horizontal slot is cut in the mounting in line with each horizontal row of lugs. Separate rows of 100 lines are separated by a groove filled with white enamel. The lugs are made of brass rods extending to the rear at which point the connection is made with the sleeve of the line circuit. On a call to an "A-B" toll operator a checking tone is connected thru the sleeve of the answering cord plug to the sleeve of the answering jack. This tone is then transmitted over the sleeve conductor of the trunk, thru the sleeve terminal, sleeve brush, and sleeve conductor of the office and district selectors, thru the transmission condenser in the district selector, thru the line finder multiple brush and sleeve terminal of the calling line, to the checking multiple lugs. When the tip of a special check tone cord plug is placed in contact with the checking multiple lug of this line, the check tone is connected from the lug to the operator's telephone circuit, thus telling the operator that the number of the calling line, as given by the calling subscriber, is the number of the line from which the call originated. This circuit is shown schematically in figure 5.

KEYSHELVES

The keyshelves used on Panel System "A" switchboards may be classified as "Semi-mechanical", "Manual Dialing", "Combination", and "Intercepting". The keyshelves at intercepting positions of the Manual dialing type and Semi-mechanical type A boards differ somewhat, although the cords used in either case are manual cords.

SEMI-MECHANICAL

A semi-mechanical type keyshelf, shown in figure 1, has a capacity of 20 semi-mechanical cords, 3 "final terminal" cords, one supervisor's cord,

one "busy-test" cord, and a semi-mechanical key set. The last 2 semi-mechanical cords may be wired and used as final terminal cords. The key set includes routing, office code and numerical recording keys (including party designations keys), and a start key; these keys are of the mechanically-locking, electrically released type. In addition a number of miscellaneous keys are provided such as the Master Listening Out key "LO", the Master Disconnect key "DISC", the Supervisor's Pilot key "SR", the Bulletin key "BUL", and the Peg Count key "PEG" these keys are of the non-locking plunger type. A Master Coin Return key "RTN" is provided when the semi-mechanical cords are equipped with "Coin Collect" keys. Four ring-back keys are furnished in four-party offices for use when it is necessary to "ring back" the called subscriber. When "verification request" calls are completed by means of cordless "B" equipment, special trunks are provided between the "A" switchboard and the cordless "B" switchboard. The "BUL" key is also a call circuit key which connects the "A" board operator with a "Bulletin Operator", who is provided with the latest records as to "change of number" or similar information.

With each semi-mechanical cord are associated three supervisory lamps (back, middle and front), a "Listening-in" key, a "Monitoring" key, and a ticket clip. These keys are of the non-locking plunger type. A non-locking coin collect key is also provided for each cord, when required. Semi-mechanical cord circuits do not have the busy-test feature, and a single-ended "busy test" cord is provided for use when the operator wishes to test outgoing trunk jacks. This cord is also used as the "check-tone" cord when "checking multiple" is provided at the special service positions. The final terminal cords are used in completing two-number toll calls, and with final terminal cord there is associated a supervisory lamp and a listening key. A supervisor's cord is provided for use by the "A" board supervisors in answering a call, or in connecting the supervisors telephone set to an outgoing trunk jack; there is a set of four ringing keys associated with this cord. A ticket-pad holder and ticket receptacle are provided on each semi-mechanical keyshelf and space is available for mounting a bulletin holder for holding routing instructions. When position clocks are required, they are furnished at alternate positions of the board.

MANUAL DIALING

The manual dialing keyshelf shown in figure 2 has a capacity of 17 double-ended cords and 60 call circuit keys. Each pair of cords is provided with a back and a front supervisory lamp, with non-locking coin collect and return keys (when required), and with front and back lever-type keys for ringing, listening and flashing on the cords. The rear key unit also serves as a "dial key" when operated away from the operator. Usually from 10 to 14 pairs of cords and 24 call circuit keys are provided. In addition to the double ended cords from 2 to 5 single ended final terminals are provided and located in the front cord space of the last cord positions. One or two test cords may also be provided from the test desk at the last manual dialing position of the A board so that the test man may test through the entire switchboard multiple when testing trunk or subscriber's line conductors which terminate at the Panel System "A" switchboard. When furnished these cords are located in the cord sockets of the first or last regular cord positions the number plates being marked "T1" and "T2". A disconnect lamp is associated with each test cord.

The dial used in connection with manual dialing cords is similar to the subscriber's dial except that it is a 20 pulse per second dial. It is mounted at the right end of the keyshelf on a semi-circular metal dial adapter by which it is fastened to the keyshelf. Provision is made for a maximum of 5 strips of call circuit keys, 12 keys per strip; for a master call circuit ringing key CCR (seldom furnished), 4 master ring-back keys and 1 master ring-forward key which are furnished in offices using four-party full selective ringing. A ticket-pad holder, a ticket receptacle and a peg count key are always provided at each manual dialing keyshelf. Position clocks are provided at alternate positions when required.

COMBINATION

A combination manual and semi-mechanical keyshelf shown in figure 3 has a capacity of 7 manual cords, 15 semi-mechanical cords, 1 busy test cord, and the semi-mechanical key set. The manual cords are located at the left, the keyshelf being split so that the manual portion can be raised independently of the semi-mechanical portion, and vice versa. The manual cord and key equipment is similar to that furnished on a manual dialing keyshelf and the semi-mechanical cord and key equipment is similar to that furnished on a semi-mechanical keyshelf, except

that call circuit keys which are required for use with manual cords are mounted on the left-hand strip of routing keys in the semi-mechanical key set.

INTERCEPTING

A keyshelf for use at the intercepting position of a manual dialing "A" board is similar to the manual dialing keyshelf except that only 5 of the cord circuits are equipped, the space for the other equipment being filled with apparatus blanks. A keyshelf for use at the intercepting position of a semi-mechanical "A" board shown in figure 3 is similar to the keyshelf of a manual dialing type "A" board except that the supervisory lamps are located on the key strips instead of being mounted in a lamp rail, and the general dimensions of the position conform to those of the other positions of the semi-mechanical type "A" board.

PANEL EQUIPMENT ASSOCIATED WITH PANEL SYSTEM "A" SWITCHBOARD - OPERATION

DIALING DISTRICTS

When a call is completed at a Panel system "A" switchboard by the use of a manual dialing type cord, the plug of the calling cord is inserted in a jack which connects to an "A" position "Dialing district selector circuit." These district selector circuits are mounted on frames similar to the regular subscribers district frames as described in Chapter X. As soon as the plug is inserted a panel type sender-selector (which is a part of the dialing district selector circuit, but which is mounted on a regular subscriber's panel-link frame) selects and connects the district circuit to an idle subscriber's sender circuit. Operation of the dial key, associated with the cord used, connects the position dial to this cord. The called office and number are dialed and registered in the selected subscriber's sender; the sender controls the completion of the call just as if it had been originated directly by a subscriber without the assistance of an operator. The connection is, however, under the joint control of the calling subscriber and "A" operator.

DIALING INCOMINGS

"Dialing incoming selectors" may be provided for completing calls to subscribers in the same office. In this case the plug of the calling cord is inserted in an outgoing trunk jack which connects to a "dialing incoming selector" circuit mounted on a regular incoming frame. As soon as the plug is inserted the

incoming selector circuit selects and connects itself to an idle "incoming-trunk sender" circuit. Operation of the dial key and dial causes the called number to be registered in the selected incoming trunk sender; the sender controls incoming and final selections, returning to normal as soon as the connection has been established. Incoming trunk senders are mounted on a "Dialing Incoming Sender and Sender-selector frame", which is of the type generally known as a single-sided frame. The framework is divided into two bays; the right-hand bay is used for mounting relays, resistances, 200-type selectors and a jack panel; the left-hand bay is used for mounting terminal strips, relays, sequence switches, a fuse panel, and a power drive. The frame has a capacity of 4 sender circuits and 9 sender-selectors. The sender-selectors belong to the individual dialing incoming selector circuits and consists of 200-type selectors. The sender circuits include 200-type selectors on which the dialed number is registered, together with the counting relays, fundamental circuit, and miscellaneous relays which are necessary in controlling incoming and final selections. The senders are used in common with "Dialing Incoming Selector circuits" which are used to complete calls from manual offices, when this method is used as described in a previous chapter.

SEMI-MECHANICAL CORD AND DISTRICT

The single-ended cords used at the special service positions of the semi-mechanical type of Panel system "A" switchboard are a part of "Semi-mechanical Cord and District Selector" circuits which mount on special district frames. These frames are of the double-sided type consisting of 5 bays. The center bay is used for mounting the banks, friction roll drive, clutches, commutators, brush rods, etc.; the 2 bays on either side of the center bay are used for mounting sequence switches; and the 2 end bays are used for mounting relays, repeating coils, condensers, resistances, etc. The multiple on an "A" position District frame is separate from the subscriber's district multiple, and is usually connected to trunks outgoing to suburban points, to tandem offices, and to two-number toll boards. In order that the "A" operator may complete calls to destinations which appear on the subscriber's district or office multiple, a group of trunks from the "A" position district multiple connect to "local tandem district selector circuits" which are mounted on a regular subscriber's district frame. One "A" operator's district frame is furnished for every 3, 4, 5 or 6 positions of "A"

board equipped with the semi-mechanical type of cord circuit, depending upon whether the positions are equipped with 20, 15, 12 or 10 cords per position respectively.

ALLOTTER, LINKS AND A SENDERS

The mechanical equipment associated with a semi-mechanical "A" position is mounted on a frame known as an "A" position "Sender and Link" frame. This is a single-sided unit-type frame, with a capacity of either 4 senders and one positional unit, or 3 senders and 2 positional units. The framework is divided into 3 bays; the right-hand bay of each unit is used for mounting the relay equipment; the center bay is used for mounting sequence switches; and the left-hand bay of the positional unit is used for mounting 200 type selectors while the left-hand bay of the sender unit is used for mounting 1203 type selectors. The positional unit for each semi-mechanical position of "A" board includes one key control circuit, one allotter circuit and 4 link circuits. The allotter circuit consists of a sequence switch which allots a maximum of 8 link circuits, in rotation. Usually 4 links are sufficient to handle the traffic at one position and the allotter passes by the positions in which it would allot the other 4 links, if furnished. A link circuit consists of a 200 type selector designated TH, which is used to find the "cord and district selector circuit" with which a call has been answered, a 200 type selector designated SS which is used to select an idle sender circuit, a sequence switch, and a number of relays, resistances, condensers, etc. Each link circuit can, therefore, find any one of the 10, 12, 15 or 20 "cord and district selector circuits" and connect it to an idle sender, in a group of 22 senders. A key control circuit, which consists of a sequence switch and a number of relays, condensers, resistances, etc., is used on all calls and connects therefore to all of the links and also to the allotter circuit. The senders are multiplied to the banks of all of the sender-selectors, the senders being used in common by the link circuits associated with as many "A" positions as are required to load a group of not more than 22 senders.

The "A" sender circuit includes a large number of relays, resistances, condensers, etc., 6 sequence switches (known as the register control switch (R1), sender control switch (R2), sender switch (R3), class switch (R4), RCI switch (R5), and route switch (R6)), and two 1203 type selectors (known as routing selectors). As soon as the "A" operator inserts the plug of the single-ended semi-

mechanical cord in an answering jack or in an outgoing trunk jack, the sequence switch in the link circuit (which has been previously allotted by the position allotter circuit and which has been awaiting a call), advances to a position in which the TH selector hunts for and connects the link circuit to this "cord and district selector" circuit. At the same time the SS selector hunts for and connects the link to an idle sender circuit. The link circuit then connects the "key control" circuit to the sender, and such register relays are operated in the sender as correspond to the route, office code, and numerical keys depressed by the "A" operator. The office code keys are used only when the call is routed to a tandem office, either manual or full mechanical; for on such a call it is necessary that the office code be transmitted, in addition to the number of the called line, so that the tandem operator or full mechanical tandem sender can complete the connection to the called office and line. The 40 route keys in the semi-mechanical keyset at the "A" position are divided, from a circuit viewpoint, into 8 groups of 5 keys each and depression of a particular route key causes the operation of certain register relays in the sender. The route relays operated cause the route sequence switch R6 to be set in a position which corresponds to the group of 5 keys in which the depressed route key is included. With the route switch so set the routing selectors (1203 type) are advanced to that one of 40 positions, which corresponds to the particular route key depressed, under control of the route switch and the route register relays. The routing selectors are similar to the translator in a 2 digit sender circuit; and the arcs of these selectors control the setting of the class switch R4, control district and office selections, and control compensation for office and incoming selections. After registration is completed the key control circuit is released for use on a succeeding call, and the link circuit connects the sender to the district, the connection being established, under control of the sender, as required for the particular class of call being made. The sender circuit returns to normal when the connection is established and the link circuit advances to the "awaiting allotment" position.

LOCAL TANDEM DISTRICTS AND SENDERS

When the call is one which can be completed only through the subscriber's district multiple the "A" sender causes the selection of a trunk which connects to a "local tandem district selector circuit" mounted on a regular sub-

subscriber's district frame, the "A" sender completing the connection as a tandem RCI class call. The tandem district selector circuit includes a 200 type sender-selector, which is mounted on a Local Sender-Selector frame. As soon as the trunk which connects to a "local tandem district circuit" has been selected, the sender-selector associated with this district circuit selects an idle "local tandem sender circuit". As soon as the tip and ring of the trunk are connected through the sender-selector to the local sender circuit the "A" sender transmits the RCI pulses corresponding to the office code and number of the called line. The pulses are recorded in the tandem sender by the operation of certain register relays. The "A" sender returns to normal after transmitting the RCI pulses and the "A" link advances to the "awaiting allotment" position. After operation of the register relays the local tandem sender functions in a similar manner to that in which a subscriber's sender functions in controlling the completion of a call, except that translation is controlled by the register relays instead of being controlled by the setting of 200-type office code registers. A sufficient number of local tandem districts are furnished on regular subscriber's district frames to handle this traffic. Usually not more than 10 local senders are required, and in many cases no local tandem districts or senders are provided. It should be remembered that local tandem district and sender circuits are not required in any case unless the semi-mechanical type of "A" board is used.

A-B TOLL CALLS

Those toll calls which can be completed by the "A" operator over direct trunks to the called office without going thru a toll board are termed A-B toll calls. These calls are completed at a manual dialing type "A" board by inserting the calling cord plug in a trunk jack on which is terminated a trunk to the desired destination; they are handled at a semi-mechanical type "A" board by answering the call with the semi-mechanical cord the outgoing trunk being selected under control of an "A" sender. The "A" operator tickets and times these calls.

METHOD OF COMPLETING TWO-NUMBER TOLL CALLS

Where the calling subscriber is making a call which in a manual system would be handled by the standard two number method of operation, the call may be completed by one of two general methods. By the first method, the "A" operator may handle and time the call, obtaining the connection through the two number

toll board. In this case, if manual cords are used, the two number toll board is reached over an idle recording trunk in the same manner as at an "A" position in a manual office; or if semi-mechanical cords are used, the two number toll board is reached over a recording trunk selected by the "semi-mechanical cord and district selector circuit" under control of an "A" operator's sender circuit, the proper routing key having been depressed. The trunk lamp at the two number board lights when the connection is made to the recording trunk (either by use of a manual cord or a semi-mechanical cord and district circuit), and after the two number operator has answered the call, the connection is completed to a toll line as directed by the "A" operator. Release of the connection is under joint control of the calling subscriber and the "A" operator. When the calling party "hangs up" the "A" operator disconnects and a disconnect signal is given at the two-number board; the toll operator then releases the toll line. This method of operation may be found desirable when the toll lines are equipped on such a liberal basis that in the majority of cases, the "A" operator can secure a toll line without material delay; it is necessary, however, that the recording trunks be of high grade to minimize the toll transmission loss.

The second method of handling two-number toll traffic can also be used at special service positions equipped with either manual, semi-mechanical, or combination equipment. Where semi-mechanical or combination equipment is used, from 2 to 5 special final terminal cords are provided with each of which is associated two supervisors lamps and a listening-in key. Where manual equipment is used, from 2 to 5 of the manual cords are wired as final terminal cords. These final terminal cords connect to sets of final multiple terminals and are given numbers corresponding thereto. After answering the subscriber, the "AB" operator removes the answering cord from the jack and replaces it by a final terminal cord. The number is then passed by the "AB" operator to the two-number operator over a recording trunk. The two-number operator establishes a connection to the calling subscriber through this final terminal cord either by the key indicator or by the cordless "B" method. The disconnect signal is given on the final terminal cord, when the two-number operator releases the switching trunk at the completion of the conversation.

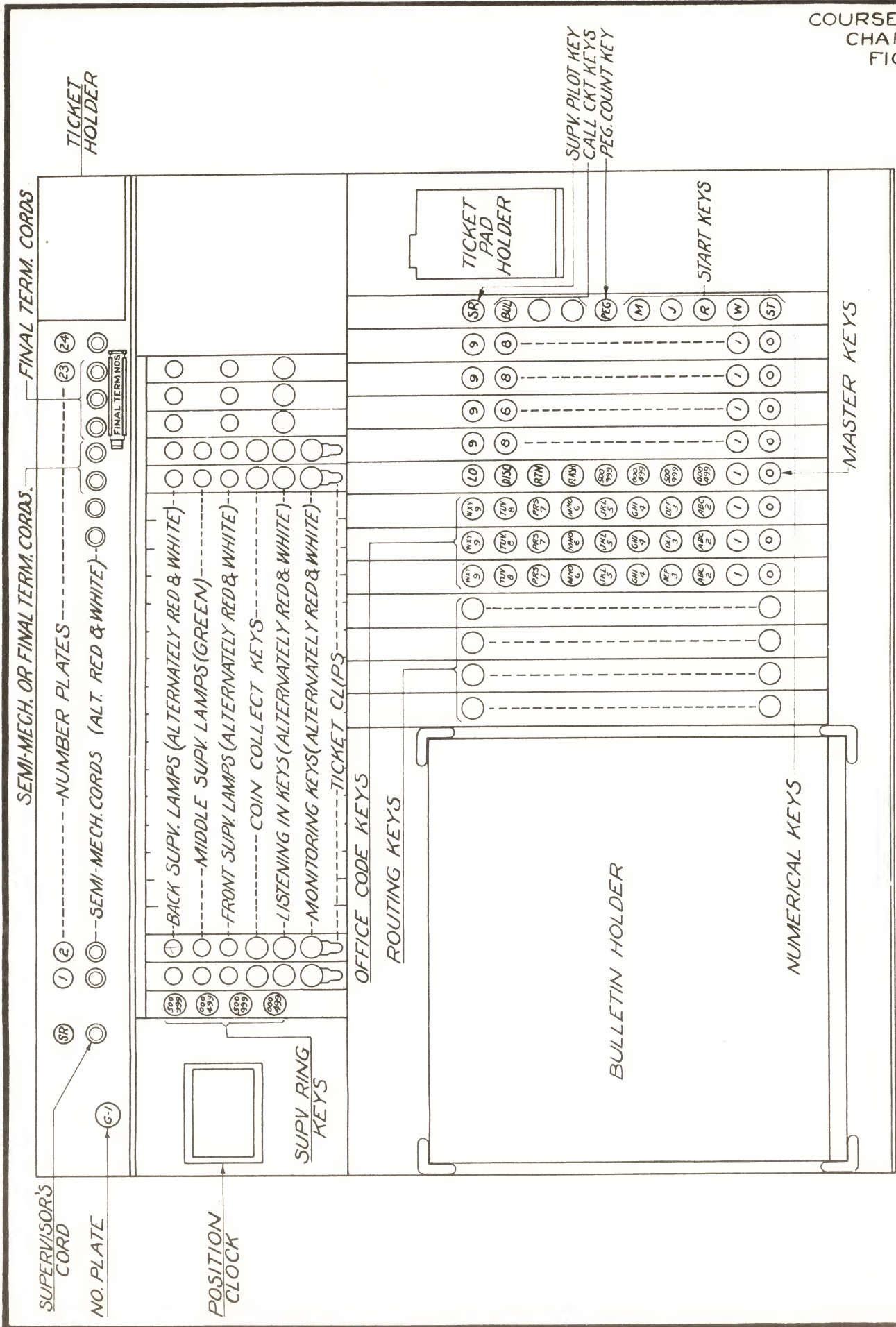

SEMI-MECHANICAL POSITION - P.M.S. "A" BOARD
 FIG. I

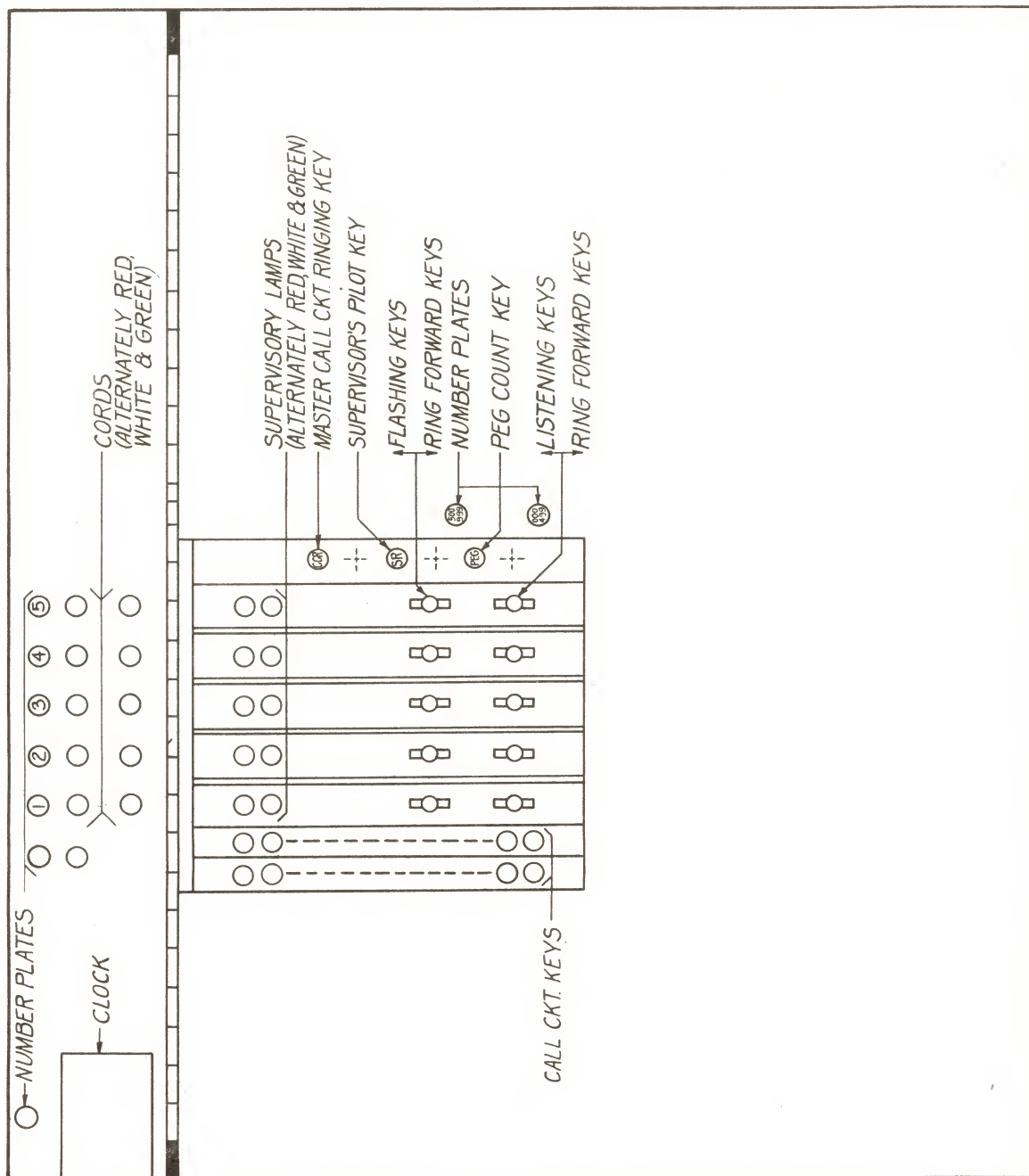

INTERCEPTING POSITION
 SEMI-MECHANICAL M.S.A. BOARD
FIG. 3

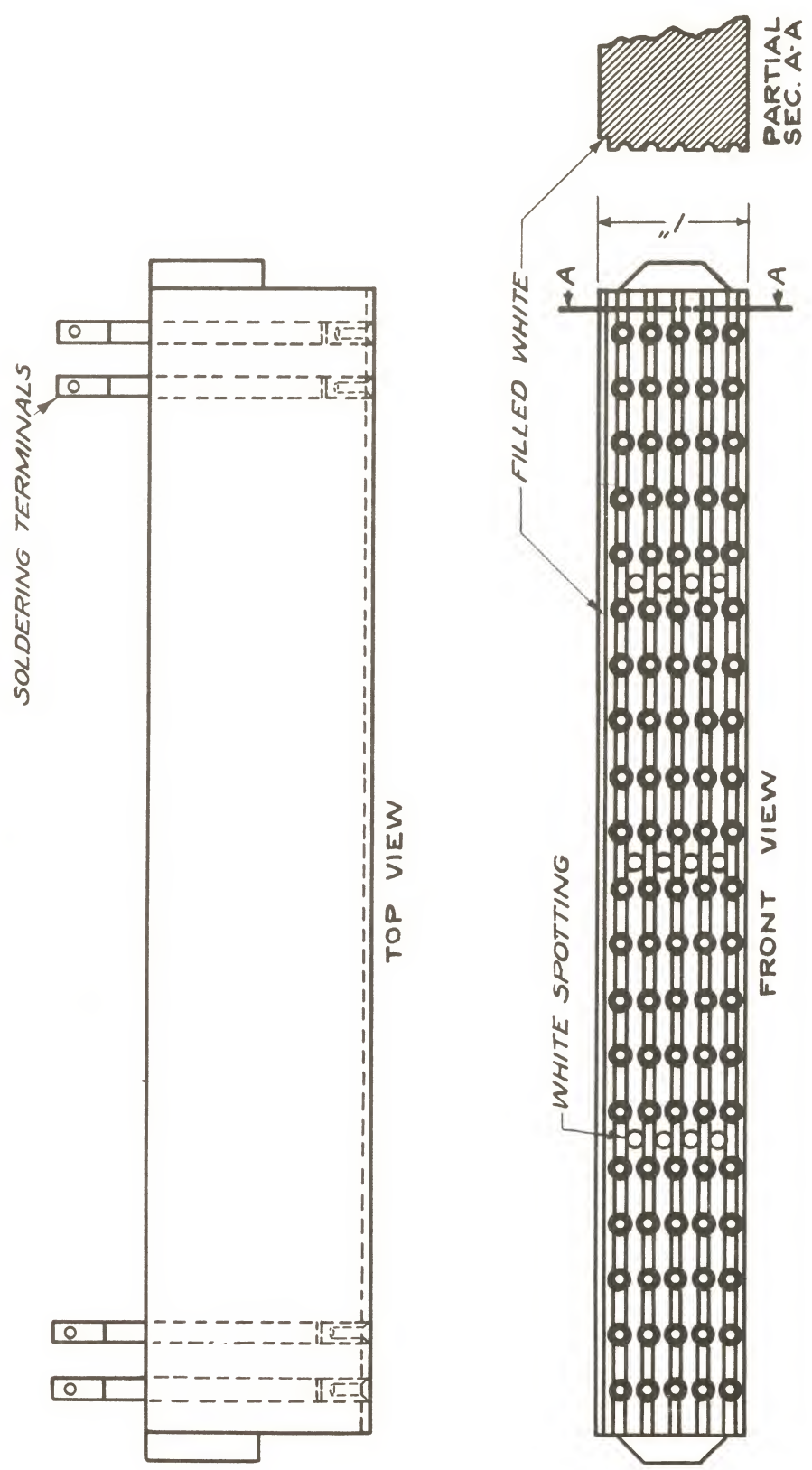

TEST STRIP FOR CHECKING MULTIPLE
MACHINE SWITCHING "A" SWITCHBOARD
FIG. 4

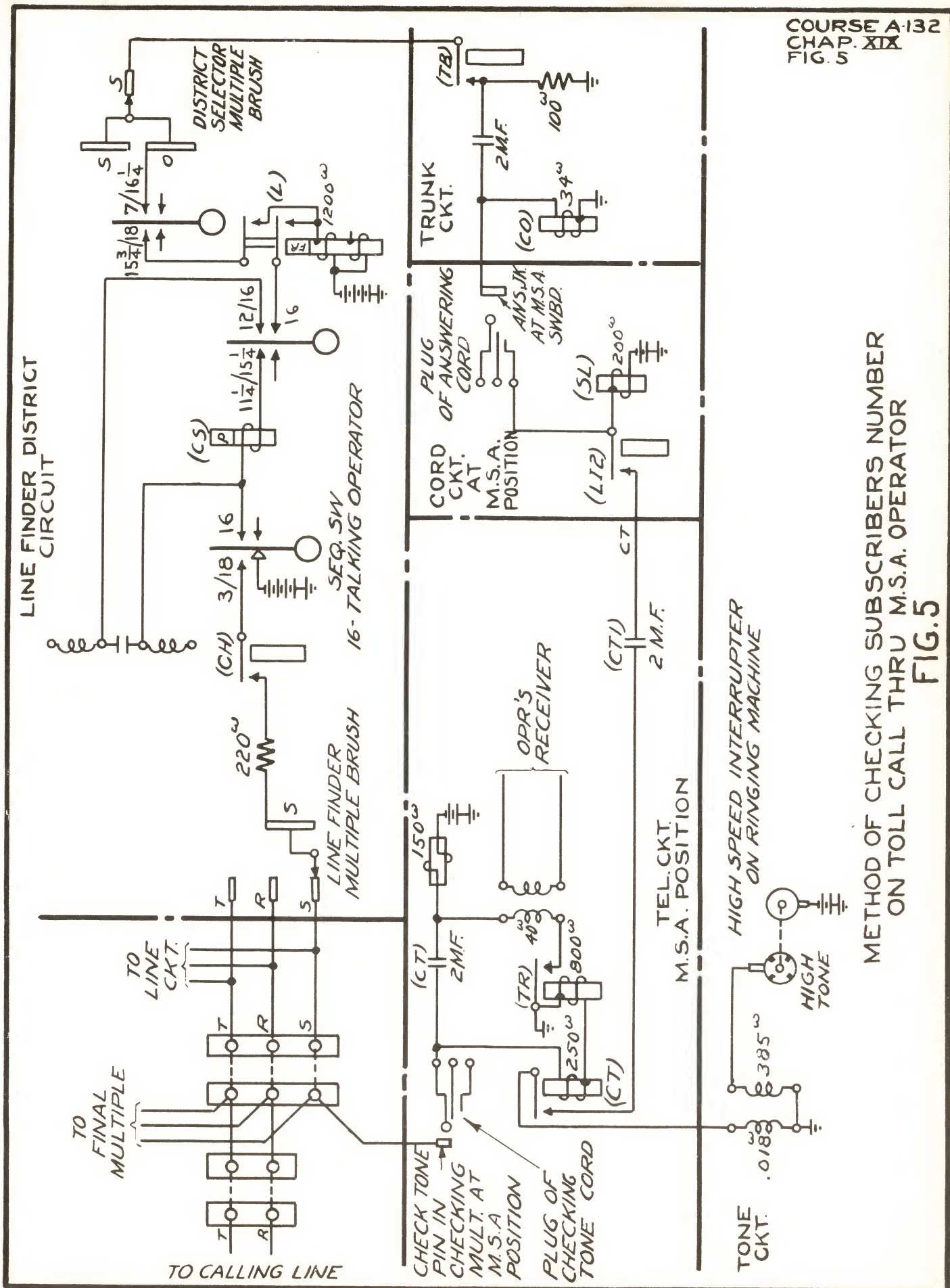

METHOD OF CHECKING SUBSCRIBERS NUMBER
 ON TOLL CALL THRU M.S.A. OPERATOR
FIG. 5

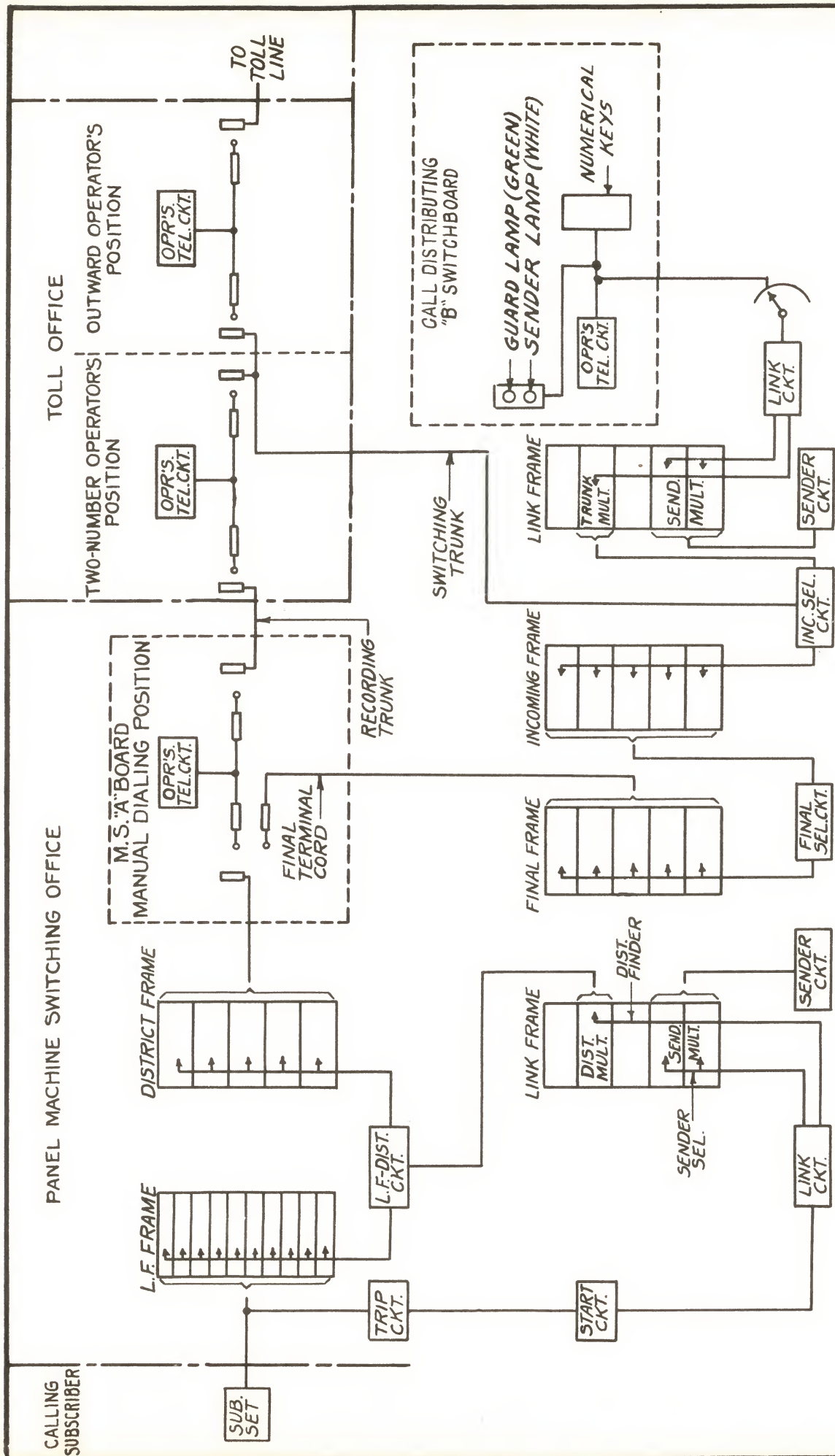

ROUTE A TWO-NUMBER TOLL CALL
 FINAL TERMINAL CORD METHOD
FIG. 6

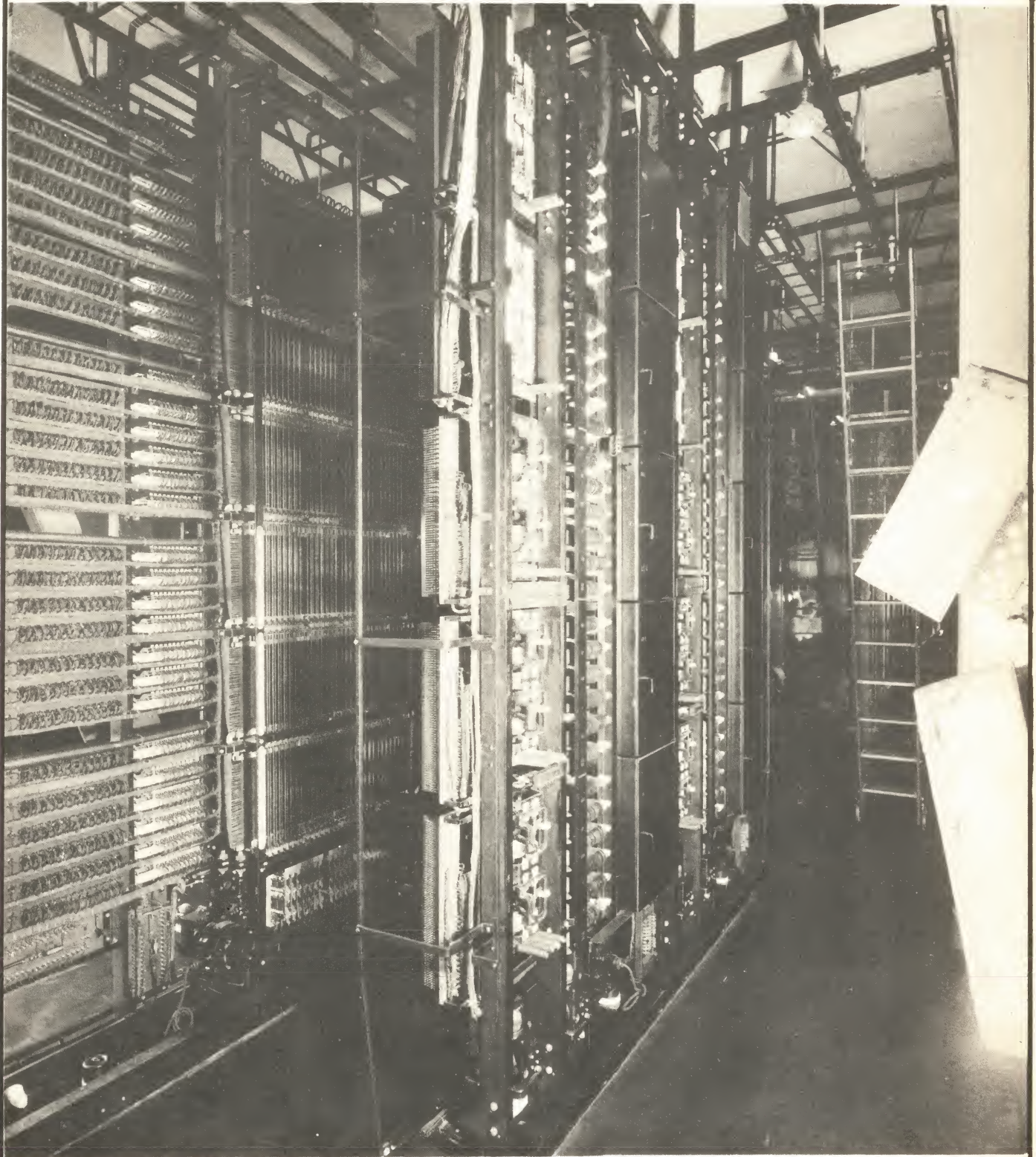

"A" POSITION SENDER AND LINK FRAME
FIG. 7

CHAPTER XX

OTHER METHODS OF HANDLING ORIGINATING TRAFFICSemi-Mechanical

The very earliest installations of Panel type equipment were made on a semi-mechanical basis. The calls are answered by "A" operators at an "A" switchboard the positions being equipped with single-ended, semi-mechanical cords and with a set of office code and numerical recording keys. The semi-mechanical "A" positions are very similar to positions of the semi-mechanical type of Panel System "A" switchboard used in Panel type offices for handling "zero" operator and AB toll traffic, (described in a previous chapter). The semi-mechanical cords are part of "semi-mechanical cord and district selector" circuits. The called number is registered in a sender circuit (there being three sender circuits serving each position) by the depression of the proper office code and numerical recording keys. A trunk to the desired destination is then selected by the district and office selectors under control of the sender. Calls which terminate in the same or another semi-mechanical office are completed by incoming and final selector circuits under control of the originating sender circuit. Calls which terminate in a manual or manual tandem office are completed over "carriage call indicator" trunks to call indicator positions at the "B" board in the manual office.

The "carriage call indicator" method is similar to the present "relay call indicator" method but differs from it in two major respects. First, the called number (and office code on tandem calls) is registered on sequence switches in the manual office instead of on relays, there being one sequence switch for each digit to be recorded. Second, instead of transmitting RCI pulses the semi-mechanical sender functions the same as if it were a call to a Panel type office. The register switches in the Manual office are advanced, in succession, under control of the semi-mechanical sender circuit; as each register switch advances it alternately connects ground to, and disconnects ground from, the tip side of the trunk or fundamental circuit. As soon as the sender is satisfied for each selection it opens the fundamental circuit stopping the register switch; all the register switches are thus stopped in those positions which will cause the called number to be displayed on a call indicator in somewhat the same fashion as the

number is displayed at the "relay call indicator" positions.

Line-Switch and Sender-Selector

When the first Panel type offices were installed, the subscribers lines terminated on individual "line-switches" instead of being connected to the multiple on line finder frames. The line-switch is a 200 type selector to whose 22 sets of terminals are connected the leads from 22 district selectors. When a subscriber originates a call, the line-switch hunts over its terminals for an idle district selector circuit; and, having found one, it makes the selected district circuit test busy to all other line-switches to which this district circuit is multiplied. A group of 22 districts is multiplied to the banks of enough line-switches to "load" the group of districts. Each district selector circuit in an installation of this kind includes a 200 type selector which is used to select an idle sender circuit, the senders also being arranged in groups of 22. As soon as a line-switch selects a district the sender-selector selects an idle sender circuit and the calling line is connected to the selected sender. Line-switches are mounted in bays, 20 switches wide, the line and cut-off relays being mounted directly below each line-switch. A line-switch bay has space for 9 horizontal rows of switches together with the 9 rows of line and cut-off relays - a total of 180 line switches per bay. The sender-selectors are also mounted in bays, 20 selectors wide but since no (L) and (CO) relays are associated therewith, there are 12 horizontal rows of selectors per bay - a total of 240 sender selectors. A line switch and district selector circuit with the sender selector is shown schematically in figure 1.

Line Finder and District with Sender-Selector

On later installations the line-switch equipment was replaced by line finder equipment which was developed as a more economical method of handling originating traffic.

The first line finder frames had a capacity of fifteen 20 point banks, a total of only 300 lines per frame (without splitting the multiple). There were, therefore, 15 regular and one emergency trip circuits and one regular and one emergency start circuit per frame. This arrangement provided for either 28, 40 or 60 "line finder districts" per group, as required by the traffic originating from 300 subscribers' lines. Each district selector circuit included a 200

type sender-selector, which was mounted on a sender-selector frame and the senders were divided into groups, 22 senders per group. This type of equipment has been installed in a large number of offices.

Rotary Links

In order to secure more efficient use of senders "Rotary Link" equipment was developed, which provided "link" circuits for connecting the district selector circuits with idle sender circuits, instead of including a 200-type sender-selector in each district selector circuit. The "rotary link" circuit uses one 1203 type selector as a district finder, and another as a sender-selector. The senders are, therefore, divided into groups of 44 senders each, resulting in a much higher efficiency per sender, and a consequent reduction in the number of senders required, in an office, as compared with the number that would be required if the sender-selector type of equipment were used. Rotary link circuits are mounted on "subscribers' link frames" as shown in Figure 2. Figure 3 is a schematic of those parts of the Line, Trip, Start, Rotary Link, and Line finder-district circuits involved in finding a calling line. In general the operation of Rotary Link equipment is the same as the operation of Panel Link equipment.

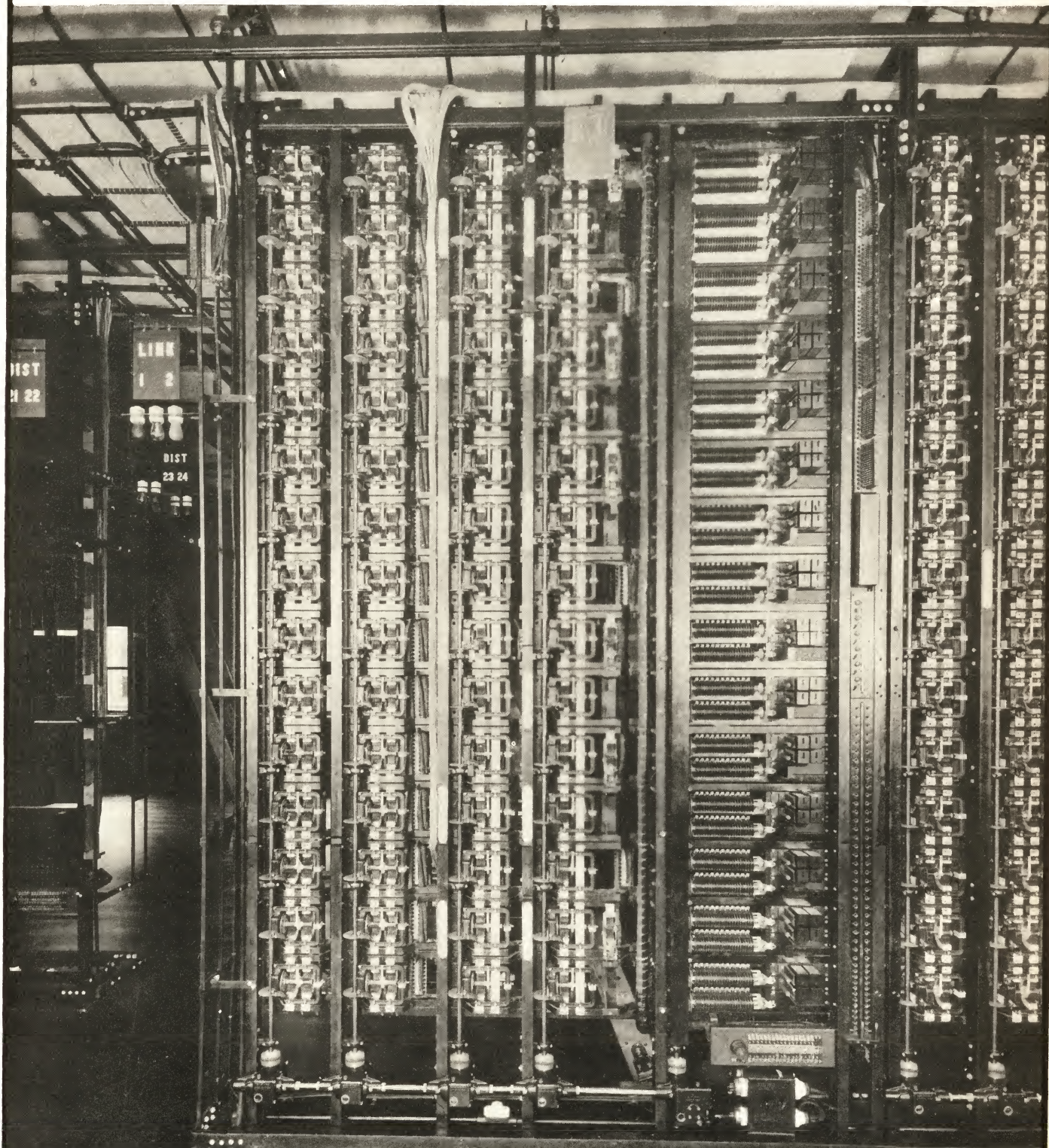

SUBSCRIBER'S LINK FRAME-ROTARY TYPE
FIG. 2

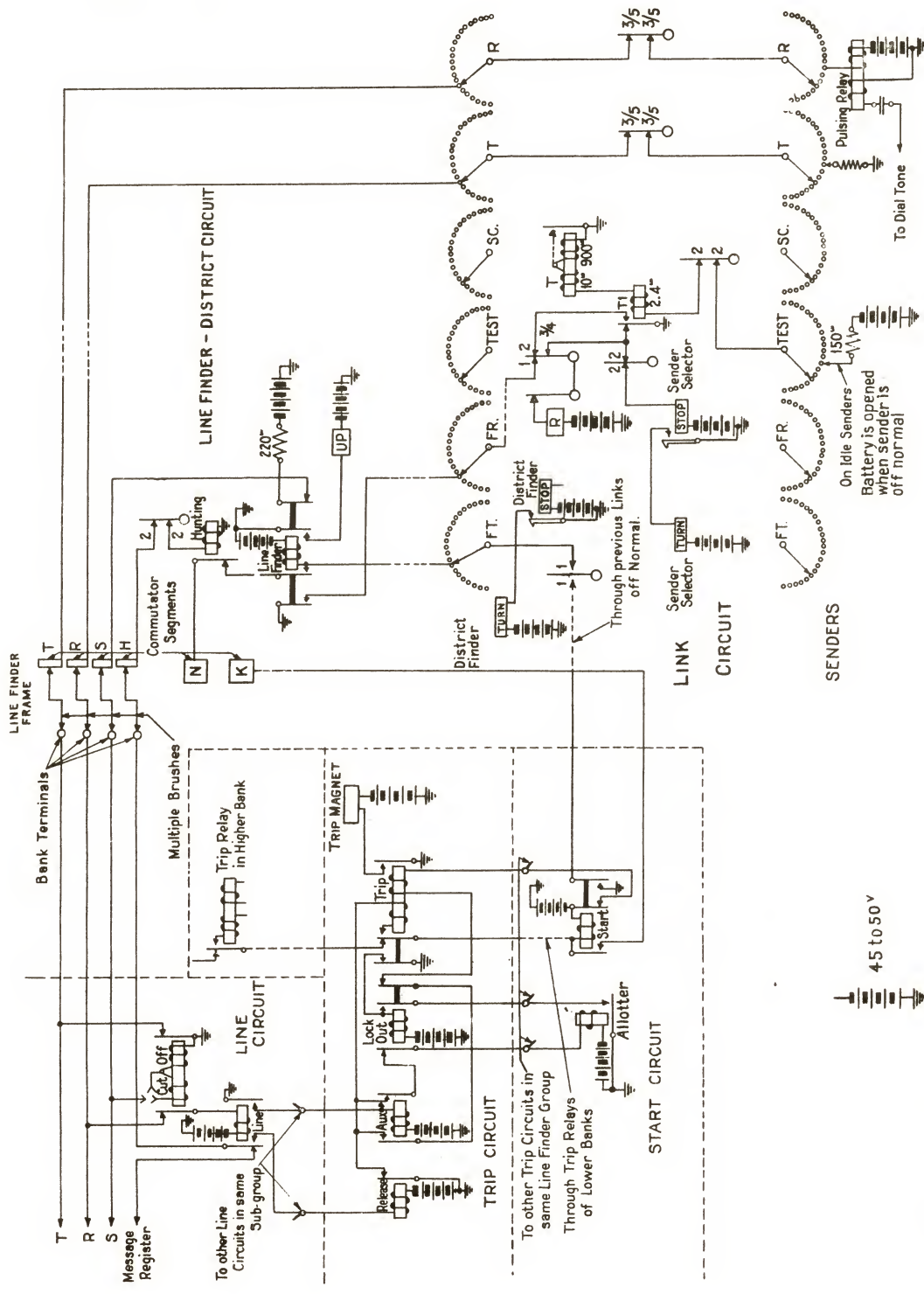

LINE, TRIP, START, LINE FINDER,
 AND ROTARY LINK CIRCUITS
 FIG. 3

45 to 50 v

CHAPTER XXI

THREE-DIGIT TRANSLATOR - EQUIPMENT AND OPERATION

A three-digit translator consists of a power driven selector on a panel type frame, used in connection with certain register relays in the sender circuit and in connection with a pulse machine which is common to all the senders. Each panel selector on the translator frame is associated with a particular sender circuit. After the office-code registers have been set this selector is driven upward for brush, group, and terminal selection so that six leads from the sender are connected, thru a pair of multiple brushes, to a particular set of 6 terminals in the selected group of the bank to which the tripped brushes have access. These 6 multiple terminals connect to the brushes on a pulse machine which make contact with "sending drums" which are divided into battery segments and ground segments. A Master Register Relay in the sender is operated over each of these leads when the sending drum brush to which the lead connects is making contact with battery segment; while these master register relays are operated another set of 6 leads from "receiving drums" on the pulse machine are connected to the windings of register relays, there being a group of register relays associated with each master register relay. When any one of the "receiving drum" brushes makes contact with a battery segment at the time that a master register relay is operated (in a sending drum lead) one of the register relays associated with this master relay is operated. That combination of register relays is operated on each call, as controlled by the sending drum leads to which the selected translator multiple terminals are connected, as will cause the sender to exercise the proper control over the various selections according to the class of call which is being made. The register relays thus perform the functions that the 1203 type selectors (two-digit translator) perform in a two-digit sender circuit.

The translator frame (shown in Figure 1) is a steel structure of a type generally known as a double-sided frame, designed for mounting the apparatus required in providing a flexible medium for connecting the pulse machine to the register relays in the sender. The frame consists of a single bay for mounting the hunting and multiple banks, the friction roll drives, the clutches, commutators, brush rods, etc. It has a capacity of 60 panel selectors, each associated with a particular sender circuit.

The translator frame is equipped with 10 multiple banks, having 40 sets of three terminal strips each, and with one hunting bank, divided vertically to make 60 vertical sets of 57 terminals each. The terminals on the 10 multiple banks connect to lamps located in "lamp and cross connecting units" which are mounted at one end of the frame, one unit for each pair of banks. The banks are arranged in pairs, six terminals being required for each office code, and the frame therefore provides for 200 different codes. The sending drum leads are cross-connected from the lamps to the various pulse leads from the sending drums of the pulse machine; the facilities for cross connection are provided by the "lamp and cross-connecting" unit in which the lamps are mounted.

The hunting bank, containing the 60 sets of 57 terminals each, is located at the top of the frame immediately below the commutators. Its terminals are connected to the terminals of the office code registers A, B and C in the sender circuits as shown in Figure 5.

The translator brush rods are similar to the line finder brush rods, being hollow metal tubes with a rack attached to the lower end and a commutator brush attached to the upper end. They are equipped with 10 brushes similar to those used on the panel link brush rods and with an additional brush for the hunting bank which has but two contact springs. The hunting brush has no separating roller and trip lever so that it does not need to be tripped in order to make contact with the terminals in the hunting bank. The first 5 slots in the rack are used for holding the brush rod in one of five positions to which it is elevated in the selection of the pair of brushes which is to be tripped on any particular call. When the rod has been elevated to a position in which the pawl has engaged with the first slot it is in position for having the first pair of brushes tripped, when it again moves upward, providing the trip magnet is then energized. Likewise when the rod has been elevated to a position in which the pawl has entered the second slot it is in a position for having the second pair of brushes tripped, etc. The tripping mechanism and friction roll drive is similar to that used on any "trunk-hunting" panel type frame. The commutator and commutator brush are modified as required for use in the translator circuit.

A pulse machine has two sets of drums to which the pulse leads from the translator frame multiple connect; one set of drums and leads are known as A drums

and A leads the other set being known as B drums and B leads. The translator frames are likewise divided into A frames and B frames so that the multiple on A frames connects to the A pulse machine leads and the multiple on B frames connects to the B pulse machine leads. It is, therefore, necessary to furnish at least one pair of translator frames for each installation. A pair of translator frames accommodates 120 senders each of which can secure a translation of 200 different settings of the A, B and C registers. Additional pairs of translator frames are provided for additional groups of 120 senders or fraction thereof for these same 200 settings of the A, B and C registers; these additional frames are placed adjacent to the first pair, the banks are multiplied together, and the lamps furnished with the first pair are used in common with the second pair. Where the number of destinations exceeds 200 it is necessary to provide another set of translator frames and pulse leads so that each sender can then secure translation of a maximum of 400 different settings of the A, B and C registers.

A pulse machine shown in figure 2 consists of 4 sets of motor-driven interrupter units mounted one above the other, each unit consisting of 23 drums on a horizontal shaft. The first (lowest) and third interrupter units each contain 19 sending, one combination sending and timing, three receiving, and one battery drum; and the second and fourth units contain 20 sending, three receiving, and one battery drum. The first and second units are designated the "A" drums and the third and fourth units are called the "B" drums. For each set of drums there are, therefore, 39 sending, one combination sending and timing, six receiving and two battery drums. Each drum is divided into two parts, a brush making contact with each part. The periphery of both halves of the battery drums is solid copper and is used for feeding battery to the battery segments on the sending, receiving and timing drums. The periphery of both halves of the timing drum and of one-half of each of the sending and receiving drums is divided into six segments and six intermediate segments alternated and separated by insulating material. The timing drum segments in both halves of the drum are connected to the battery feed drum. The periphery of the other half of each of the sending and receiving drums is solid copper and the brush making contact therewith feeds ground through this solid half to such segments of the other half as may be connected therewith. Each one of the receiving drums has a different one of its metal segments connected

with the battery feed drum, the remaining segments being connected to the ground feed half of the same drum. Each one of the 40 sending drums has a different combination of its segments connected to its ground feed or to a battery feed drum. To illustrate, sending drum No. 0 has its No. 1 segment connected to battery and all other segments connected ground, while drum No. 32 has segments Nos. 1, 2 and 4 connected to ground and segments Nos. 3, 5 and 6 connected to battery. The leads from the brushes making contact with the interrupter half of the sending drums are wired through the pulse machine fuse board to "lamp and cross-connecting unit" on the translator frames; the sending drum leads are then cross-connected to the pulse lead lamps which are mounted on the same unit. The leads from the brushes making contact with the interrupter half of the receiving and timing drums are wired thru the pulse machine fuse board to the sender pulse fuse board where connection is made to leads from each sender. See Figures 3 and 4.

The pulse machine drums are rotated at the rate of 80 revolutions per minute. The brushes are in contact with the interrupter segments for intervals of .096 second, separated by intervals of .029 second. The segments of the receiving drums make contact .024 second later than the segments on the sending drums.

In order to divide the load and insure continuous service, the terminals in the banks on odd numbered translator frames are cross-connected to the pulse leads from the "A" frames and the terminals on the banks of the even numbered frames are cross-connected to the pulse leads from the "B" drums. Not more than 25% of the translator brush rods associated with any sender group are located on the same side of any translator frame. To further insure against any interruption in service three separate pulse machines are provided on each installation; the sending, receiving, and timing leads from the A and B drums of the three machines are wired thru 6 manually operated multiple transfer switches, which are located on the pulse machine fuse board; these switches make it possible to connect the leads from the translator frames and associated senders to the drums on any one of the 3 pulse machines. (The A leads are always connected to A drums and the B leads to B drums). The pulse machine is provided with an automatic alarm device which operates when the pulse machine (which is in use) stops.

Figure 5 is a circuit schematic of that portion of the sender circuit,

including the pulse machine and translator frame, which is necessary to the explanation of three-digit translation. The terminals in the hunting bank and the hunting brush are used in setting the translator brush rod in the required position on a particular call. Terminals 1 to 4 and terminals 6, 8, 10, 12 and 14 in the hunting bank are not used. Terminals 5, 7, 9, 11 and 13, in each of the 60 vertical sets of terminals, are cross-connected to terminals on the A3 and B2 register arcs, and are used for translator brush selection. Terminals 15, 23, 31, 39 and 47 are cross-connected to terminals on the A4 and A5 register arcs and are used for translator group selection. The other seven of the eight terminals in each one of the five groups (15 to 22 inclusive, 23 to 30 inclusive, 31 to 38 inclusive, 39 to 46 inclusive and 47 to 54 inclusive) are cross-connected to terminals on the C2 register arc. When the A and B registers have been set and the RC switch is advanced to terminal 2 the (ST) relay operates and locks to off normal ground. The (TC) relay operates and locks through both windings in series under control of the (TS) relay. Operation of the (TC) relay advances the translator control switch to position 2 where the translator UP magnet is energized for brush hunting. The ground on register arc B2 and through arc A3 (according to the setting of the registers) and through one of the brush hunting terminals in the hunting bank, operates the (TS) relay when the hunting brush on the translator brush rod makes contact with this grounded terminal. Operation of the (TS) relay releases the (TC) relay. The UP magnet holds to the C commutator until the elevator has been driven upward far enough to permit the pawl to engage with the corresponding slot in the brush rod rack. Brush selection has thus been completed and the release of the (TC) relay advances the translator control switch to position 3. In position 3 the TRIP magnet associated with this translator brush rod is operated. The (TC) relay is again operated in position 3 advancing the switch to position 4 in which position the (TC) relay holds under control of the (TS) relay and closes the UP magnet circuit. When the selector moves upward for group selection the pair of multiple brushes corresponding to the selected brush terminal in the hunting bank are tripped. When the hunting brush makes contact with that one of the group selection terminals (15, 23, 31, 39 or 47) to which ground is connected through arcs A6 and B5 or thru arcs A6, B5 and A4, relay operates, releasing the (TC) relay and stopping the hunting

brush on the grounded terminal. Group selection has thus been completed and the release of the (TC) relay advances the switch to position 5. The (TC) relay re-operates in position 5, advancing the switch to position 6, in which position the (TC) relay holds under control of the (TS) relay and energizes the UP magnet for terminal selection. When the hunting brush makes contact with the terminal to which the ground from the C2 register arc is connected, the (TS) relay once more operates, releasing the (TC) relay and stopping the hunting brush on the grounded terminal in the selected group of hunting bank terminals. The release of the (TC) relay advances the translator control switch to position 8. When the terminal is the first one in the group the (TS) relay reoperates in position 5 3/4 releasing the (TC) relay and preventing the UP magnet from being energized.

We now have the tripped pair of multiple brushes making contact with six terminals, three in each of the two 40-point banks to which this pair of brushes has access. Each one of these six terminals is connected through a lamp to a terminal on the class (CL), district brush (DB), district group (DG), office brush (OB), office group (OG) and talking selection (TS) terminal strips and from there cross-connected respectively to six of the pulse leads from the sending drums of the pulse machine. When the translator control switch entered position 7 the (PC) relay was operated connecting these six terminals through the tripped pair of multiple brushes to the six master register relays designated CL-A, DB-A, DG-A, OB-A, OG-A, and TS-A, thus causing operation of these relays when the sending drum brushes to which they are connected make contact with battery segments of the sending drums. Operation of these relays causes operation of the (CL-B), (DB-B), (DG-B), (OB-B), (OG-B) and (TS-B) relays in local circuits. The six pulse leads from the receiving drums of the pulse machine are multiplied to six normally open contacts on each of these six (B) relays. With each (B) relay is associated a group of from 4 to 6 register relays of which certain ones must be operated on a given call by pulses from the receiving drums of the pulse machine. Of the relays associated with the (CL-B) relay, the (CL-1), (CL-2), (CL-3) and (CL-4) relays control the setting of the class switch, the (CL-5) relay controls preliminary coin test, and the (SO-6) relay is operated when no office selector is used in completing a call. Of the

relays associated with the (DB-B) relay, the (DB-1), (DB-2) and (DB-3) relays control district brush selection, and the (C-4), (C-5), and (C-6) relays control the compensating resistance used for office and beyond office selections. Of the relays associated with the (OB-B) relay, the (OB-1), (OB-2) and (OB-3) relays control office brush selection, the (C-4A) relay is used with the (C-4) relay (previously mentioned) to control the compensating resistance, and the (R-5) relay controls the setting of the class switch for special routes and is used only when special routes are required. Of the relays associated with the (DG-B) relay, the (DG-1), (DG-2), (DG-3) and (DG-4) relays control district group selection, and the (Z-5) and (Z-6) relays control restricted service calls. Of the relays associated with the (OG-B) relay, the (OG-1), (OG-2), (OG-3) and (OG-4) relays control office group selection and the (TW-6) relay is necessary when a two-wire office selector is used. Of the relays associated with the (TS-B) relay, the (TS-2) and (TS-3) relays control talking selection, the (SD-4) and (SD-5) relays cancel the "stations delay" feature on calls where it is not necessary to wait for the STA register to be set, and the (ST-6) relay controls "trunk test" on low resistance trunks.

To illustrate the operation of the register relays, assume the (PC) relay operated. The (DG-A) relay operates when the sending drum brush to which it is connected makes contact with a battery segment of the drum. The (DG-B) relay is thus operated, thereby connecting the six pulse leads from the six receiving drums of the pulse machine to the (DG-1), (DG-2), (DG-3), (DG-4), (Z-5) and (Z-6) relays. During the time that the (DG-B) relay is operated certain ones of these register relays are operated when the receiving drum brushes to which they are connected make contact with battery segments on the receiving drums. The register relays which are thus operated lock in local circuit. In like manner such of the other groups of register relays are operated (by battery pulses from the receiving drums, during the time their control relay is operated over a lead to a sending drum) as will set up control conditions to govern some portion of the sender's cycle of operations.

The length of time during which the (PC) relay remains operated, so as to cause operation of the register relays, is controlled by the timing drum in such a manner that the sending and receiving drum pulse leads are connected to

the register relays for at least one full cycle of pulses (one revolution of the pulse machine drums). When the translator control switch enters position 8 the lead from the timing drum is connected through a 1200 ohm resistance through the windings of the (STP) and (OFL) relays and through another 1000 ohm resistance to ground. The (STP) relay is thus alternately operated and released as controlled by the six battery segments on the timing drum. The first operation and release of the (STP) relay operates the No. 6 pair of counting relays. When the timing drum has completed one revolution and contact is made with the first battery segment on the second revolution, the (O) counting relay operates, followed by operation of the (BO) and (FO) relays when the stepping relay releases. Operation of the (FO) relay advances the translator control switch out of position 8, thus opening the pulse leads. With translation thus completed the sender proceeds with the completion of the call.



TRANSLATOR FRAME
FIG. I

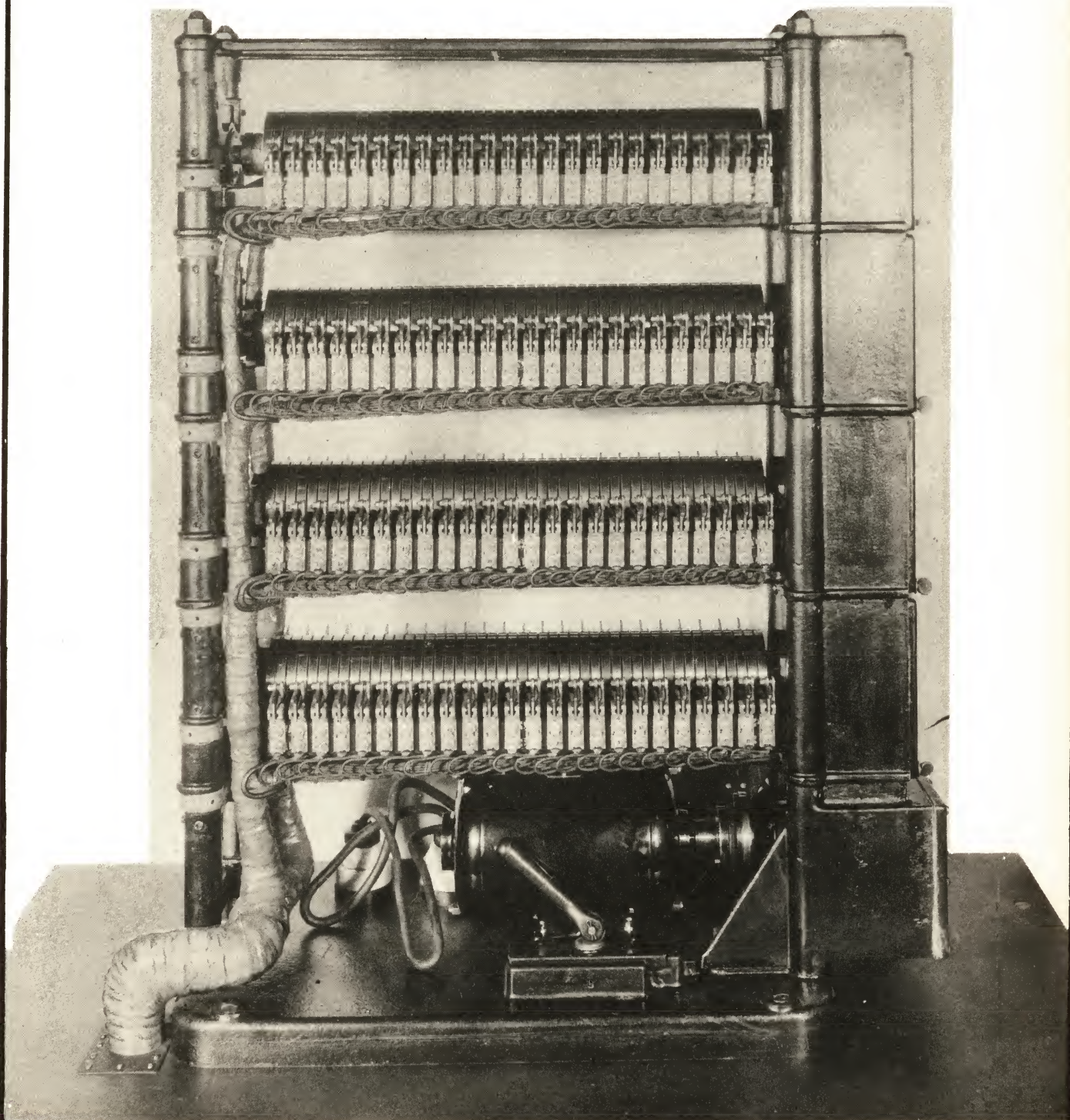

PULSE MACHINE-COVER REMOVED
FIG. 2

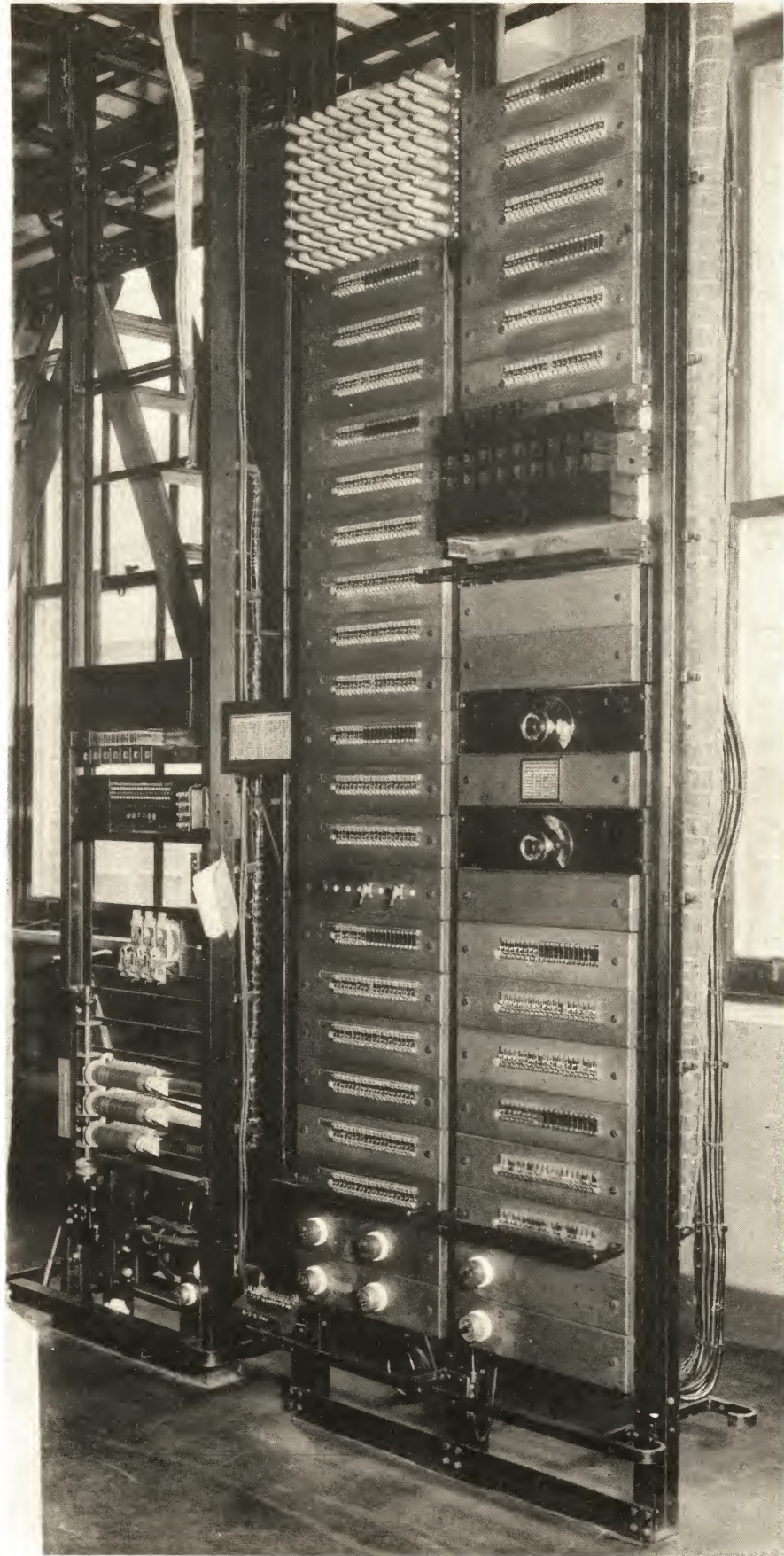

PULSE MACHINE FUSE BOARD
FIG.3



DSTB. FUSE
PANEL-1
TRANS.
FUSE PANEL

SENDER PULSE FUSE BOARD
FIG. 4

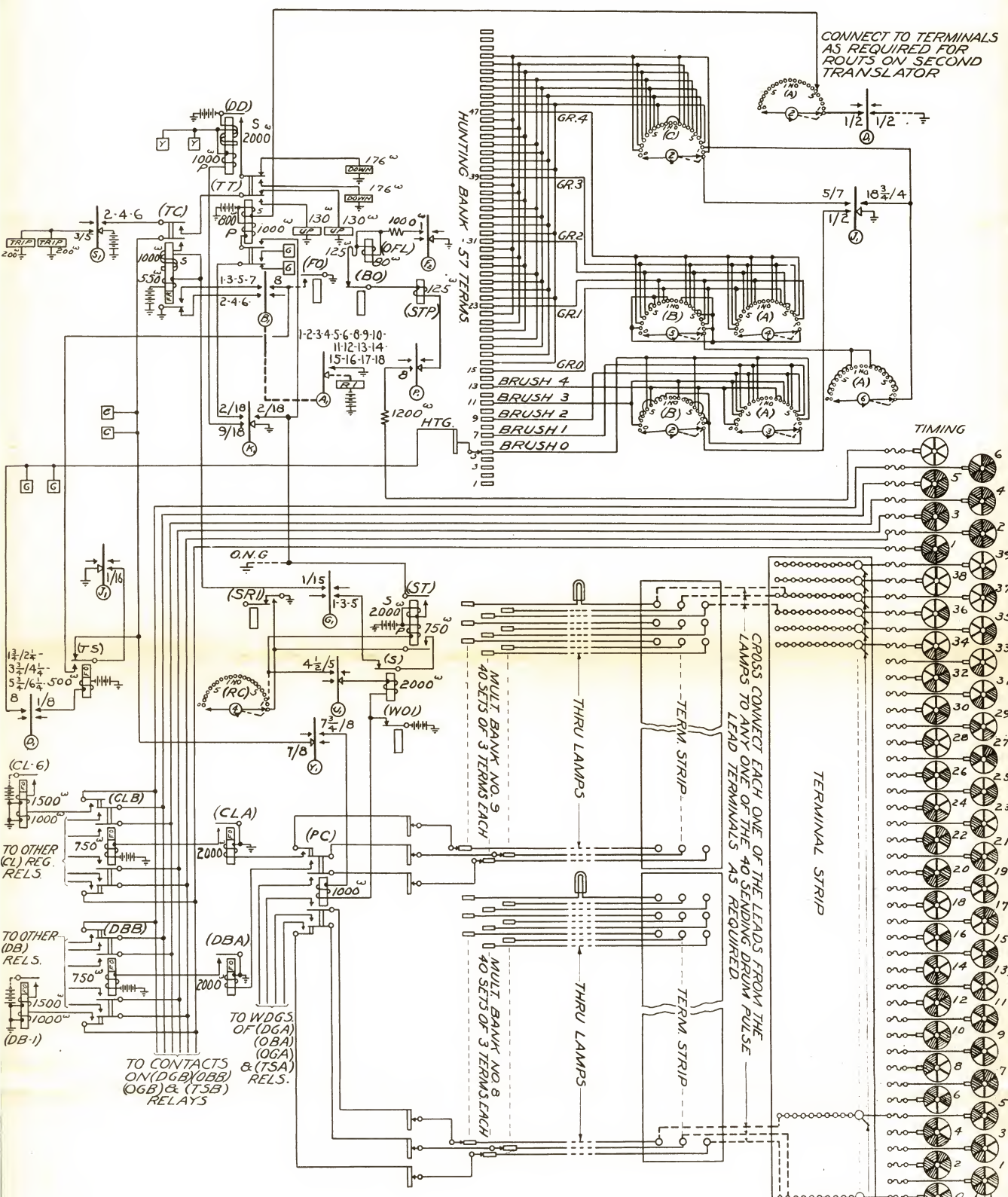

- SEQ SW. (R1)
- 1- NORMAL
 - 2- BRUSH HUNTING
 - 3- AWTG (TC) REL.
 - 4- GROUP HUNTING
 - 5- AWTG (TO) REL.
 - 6- TERM HUNTING
 - 8- PULSE COUNT
 - 9- ADV. SDR AWT-SDR
 - 10- FINAL BRUSH SEL.
 - 11- AWTG (S) REL.
 - 12- TENS SEL.
 - 13- AWTG (S) REL.
 - 14- UNITS SEL.
 - 15- RCJ IMPULSES AWTG (AV) REL.
 - 16- INCOMING ADVANCE
 - 17- AWTG (1A) REL.
 - 18- TALK SELECTION

- SEQ SW. (R2)
- 1- NORMAL

TO OTHER TERMINAL STRIPS ON SAME AND OTHER TRANSLATOR FRAMES

4" GROUND INSULATION 48 V. BAT.

TRANSLATION
3 DIGIT SENDER

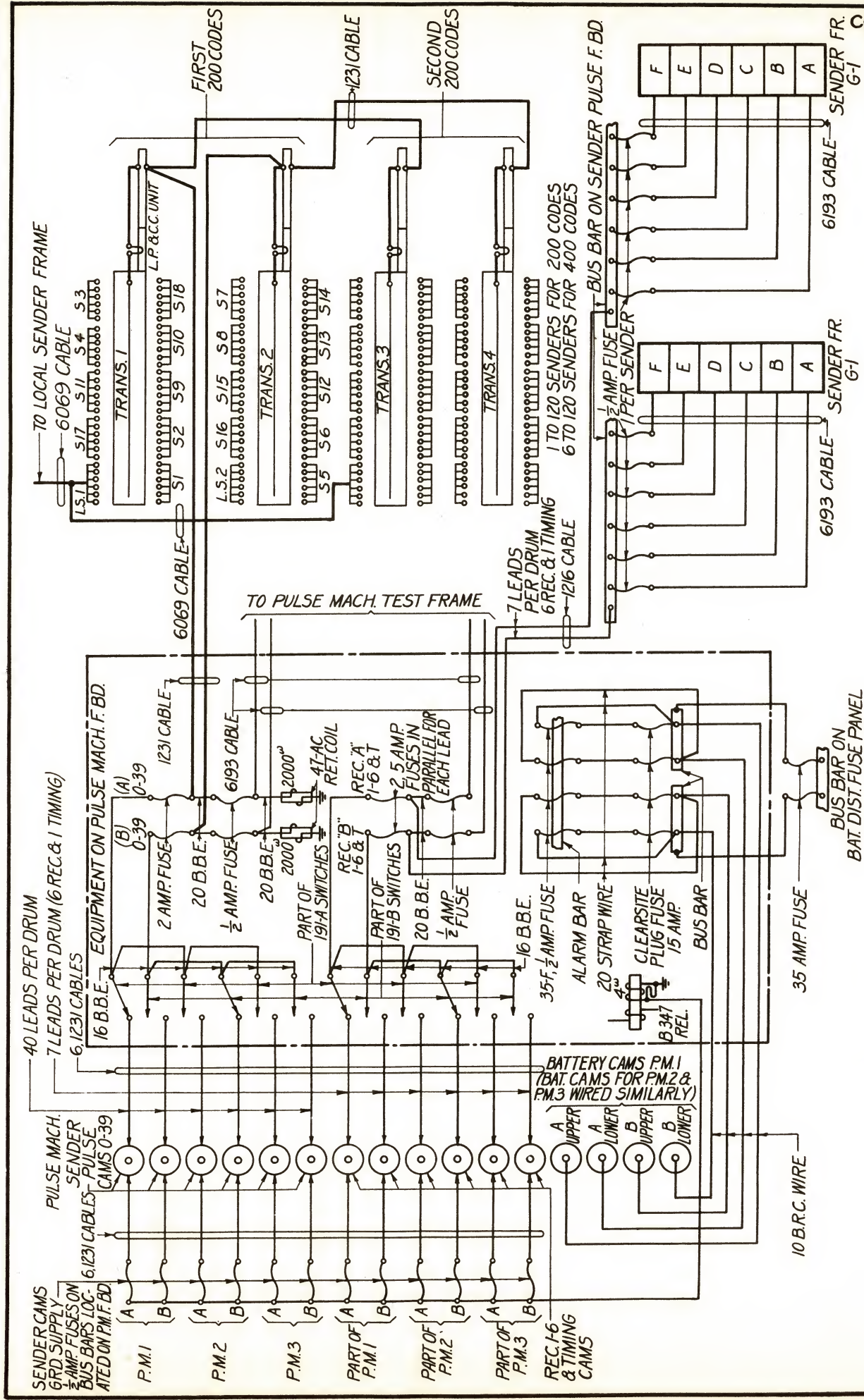

METHOD OF CABLING BETWEEN SENDERS, TRANSLATORS,
 AND PULSE MACHINE FUSE BOARD
FIG. 6

CHAPTER XXI-A

THE DECODER AND DECODER SENDER

The most spectacular development in the panel system in recent years is the decoder. The function of the decoder is the same as that of the pulse machine translator which it will replace; that is, to give the sender the necessary information for reaching the distant office and the method for transmitting the number.

The use of the decoder will result in a reduction of initial cost in equipment, floor space and maintenance, and in increased speed and accuracy. The equipment for decoding the office code in a typical office will consist of six decoders, one cross-connecting frame and a decoder connector circuit for each group of ten senders. The apparatus consists chiefly of "R" type and multi-contact relays. The multi-contact relay is a recent development designed for a very heavy spring pile-up having fifty-two make contacts. It is essentially a power driven interrupter with the cam actuating mechanism replaced by a powerful electromagnet.

THE DECODER SENDER

Before taking up the decoder it would be desirable to become familiar with the sender since it differs radically from the translator sender. In fig. 8 is shown a sender frame with only one unit mounted. Four other units can be mounted above it. A unit is made up of two senders with the relay cabinets in the end bays and the sequence switches of which there are only three, each in the middle bay. Since there are no 200 type selector switches the number of exposed base metal contacts has been materially reduced as well as the initial cost and maintenance.

The dialed number is registered on relays as shown in fig. 1. The number register circuit has been arranged into groups according to their various functions:-

- (1) The dial pulse control circuit consists of the (L), (L1), (RA) and (SR) relays whose functions are similar to those in the translator sender.

- (2) The dial pulse counting circuit consists of ten relays designated (P1), (P1') to (P5) and (P5'). This circuit unit, under control of the back contact of the (L) relay and front contact of the (RA) relay will count each train of pulses. The table on fig. 1 shows the combinations of relays operated corresponding to the digit dialed.
- (3) The register groups, one for each digit, consist of four relays each whose designations are made up of the letter corresponding to the digit it registers and the numerical suffixes (1), (2), (4) and (5) respectively. Thus the thousands register group is designated (TH1), (TH2), (TH4) and (TH5). The table in fig. 1 shows the combinations of the relays operated corresponding to the digit registered. It should be noted that the sum of the numerical designations of the relays operated is equal to the number of pulses in the digit. Thus if the units digit is eight, relays (U1), (U2) and (U5) will be operated.

In the "A" register it will be observed that the locking path for the (A1) relay is complete only when the (A2) or (A5) relay is operated. Then if a one is dialed or if the switchhook is accidentally moved causing a momentary open no number is registered.

In the "B" register the locking path for (B4) relay is opened when both (B1) and (B5) relays are operated. Hence if a zero is dialed a six will be registered. The "C" register has the same arrangement. If the subscriber dials a zero for the second or third digit of the office code it is assumed that he intended to dial the letter O which is in the "6" finger hole.

- (4) The register control circuit consists of cut-in (C), and lock-up (L) relays, one pair for each digit. These designations are prefixed with the letter corresponding to the register group as (AC), (AL), (BC), (BL), etc. The cut-in relays connect contacts in the dial pulse counting circuit to the windings of its associated register relays. When the digit has been registered the lock relay operates from the back contact of the (RA) relay in series with locking windings of the operated register relays. The lock relay operating re-

leases the associated cut-in relay and operates the succeeding cut-in relay in preparation for the next digit.

As soon as the complete office code or zero operator has been dialed as indicated by the operation of the (CL) or the combination of the (A1), (A4) and (AL) relays a circuit is established for operating the (ST) relay which places off-normal battery on the (ST) lead to the decoder connector circuit as a signal that it is ready for decoding. The connector will then seize an idle decoder and connect it to the sender thru approximately fifty leads. The decoder then receives the office code and gives the sender the necessary information by causing a combination of the selection register relays to operate. The method by which this is accomplished will be taken up separately later.

In fig. 2 are shown the selection register, counting relays and miscellaneous control relays necessary for the normal progress of a full mechanical call. The selection register relays are operated in such combinations that, except for district brush, the sum of the numerical designations of the relays operated is equal to the selection desired. For a "zero" no relays are operated. For Office Group "three" relays (OG1) and (OG2) are operated, etc. For District Brush "zero", "one" and "two" the above rule holds but for district brush "three" relays (DB1) and (DB3) are operated and for district brush "four" relays (DB2) and (DB3) are used.

The function of the selection register relays is to provide a means for connecting the contact of the stepping relay to the windings of the correct pair of counting relays required for each particular selection. The numbered circles at the registers are connected to the corresponding numbered circles at the counting relays. It should be noted that the counting relays are "split". By the use of the relay register it was possible to simplify the wiring as illustrated by a special case: If District Group "three" is to be made the contact of relay (STP) should be connected to the winding of counting relay (3) and the front contact of relay (1') should be connected to the winding of relay (0). Consulting the legend for the selection control switch it is found that district group selection is accomplished in position

3. Then the stepping relay contact goes thru cam (H), thru the collar to cam (J), thru brush #2 to the (DG) register group. For district group "three" (DG1) and (DG2) are operated. Hence the lead we are tracing goes thru the front contacts of both relays to the winding of counting relay (3). After three pulses have been received this lead will be connected to lead "0" on the front contact of (1') which goes to cam (K) thru brush #2 and thru the back contact of relay (DG5) to the winding of relay (0). Now if district group eight had been desired relay (DG5) would have been operated and the above lead would have gone to the winding of relay (9) and after five more pulses would have gone thru the front contact of relay (5') directly to the winding of relay (0). Other features of this circuit will manifest themselves as we trace the progress of a call.

As soon as the first digit has been dialed as evidenced by the operation of relay (AL) in fig. 1 ground is placed on the (ST) lead which goes to (B) cam of the selection register switch causing it to move to position 2. When the decoder has set up the selection register it grounds the (RL) lead which operates the (RL) relay causing all operated relays to lock under control of the (M) cam to ground from the (SB) relay. The operation of relay (RL) also closed the fundamental circuit which is traced from (FT) lead thru (OF) and (STP) relay windings, thru make contact of (RL) relay, back contact of (BO), make contact of (FO3) and thru the (L) cam to lead (FR). This causes the (L) relay in the district selector circuit to operate in series with the (STP) relay. The (OF) relay will not operate since the current is not in the right direction. Since the switch is in position 2 the selection is under control of relay (DB1), (DB2) and (DB3) which will connect the front contact of (STP) relay to the proper counting relay. Lead "0" is connected thru (K) cam directly to the winding of relay (0). Then as the selector is moved upward the (STP) relay is shunted down for each commutator segment crossed causing the successive operation of the counting relays until the (BO) relay operates which opens the fundamental circuit and releases the district (L) relay. Relay (FO) also operated causing the operation of (FO1) which, (a) locked to (C) cam, (b) released the odd numbered

counting relays, (c) prepared a path for moving the sequence switch out of position 2 and (d) operated (FO2) relay in turn releasing (FO3) relay which opens the fundamental and releases the rest of the counting relays. When (FO) released the sequence switch moved to position 3 releasing (FO1). The (FO2) relay being slow to release prevents the immediate reoperation of (FO3) in order that the fundamental circuit will not be reclosed before the switch has moved out of position 2.

In position 3 the fundamental is closed as before; but this time selections are made under control of the (DG) relays. The (DG5) relay will in this case determine whether lead "0" is connected directly to relay (0) or to relay (9). The switch is moved out of position 3 as described for District Brush selection.

In position 4 office test is made by running the fundamental circuit thru the (TG) relay and a high resistance of 14,500 ohms. If the trunk has battery and ground the (TG) relay will operate but the (STP) relay and the office (L) relay will not. This moves the switch to Office Brush position. Office Brush and Office Group selections are made in a manner as described for District selections.

In order to simplify the wiring it was found desirable to use the selection register relays for Incoming and Final selections as well as for District and Office selections. This is done by releasing the decoder setting and transferring the numerical register setting as will be seen later.

✓ Having completed Office selections the switch is in position 7 where the outgoing trunk is tested by means of the (TG) relay. In position 7 the (THT) relay is operated provided the thousands digit has been dialed and the setting is transferred to the (IS) and (DB) relays. The previous set-up on the (DB) relays was released when the switch moved out of position 3. With relay (THT) and (TG) operated the switch is moved to position 8 where incoming brush is made and the switch advanced to position 9. In this position the hundreds digit is registered on (DG1) and the (OB) relays. The operation of (HT) moves the switch to position 10 where Incoming Group selection is made. Incoming Group selection is controlled by relays (DG1) and (DG2).

(DG1) relay is operated if hundreds is greater than 4 and (DG2) relay is operated if thousands is an odd number.

The switch is moved out of position 10 in the regular manner and the (HT) relay being operated it goes immediately to position 12 where Final Brush selection is made under control of the (OB) relays. Final Brush, Final Tens and Final Units selections are made similarly as described above. In position 17 the incoming puts a momentary reverse battery and ground on the fundamental operating the (OF) and (STP) relays. The (OF) operates the (IA) which locks and the (STP) operates the (O) which locks in series with (BO) and (FO). When the (FO) operates the switch is moved as for District selection. In position 18 Talking selection is made in the district circuit under control of the (TS) relays. At the completion of this selection the sender is restored to normal and the connection has been established.

If the foregoing call had been destined for a manual or a tandem office the sender, after trunk test in position 7, would have handled the call differently. For instead of controlling panel selectors in the distant office it would have primed a relay call indicator circuit. How the two-digit sender accomplished this was explained in chapter (15). The purpose of this discussion is to show how relay call indicator pulses are generated when controlled by a relay register.

Each pulse must either operate a lamp relay or pass it by. Hence there are two conditions that the pulse may have. A digit requires four relays for registration thus four pulses are sent for each digit. The first and third pulses may be either positive or grounded while the second and fourth are either light negative or heavy negative. The grounded pulses are for the purpose of discharging the cable to allow the polarized relay to release. By this arrangement no consecutive pulses are alike and the control circuit will be able to differentiate between them. The chart shown in fig. (6) illustrates graphically how the pulses are constructed. The axis of abscissa is the horizontal line marked "o" which let us assume is the base or ground line. The area above this ground line represents a positive pulse while below, a negative pulse. Since a positive pulse has battery on the tip

and ground on the ring side of the trunk the ground line is designated "R" and the + line "T" in the first and third quadrants. Since a negative pulse has ground on the tip and battery on the ring the ground line of the second and fourth quadrant is designated "T" and the negative, either light or heavy, is designated "R". It will therefore be seen that the ring will always be grounded in the odd positions of the switch while the tip is grounded in the even positions. This is done on cam (F1) thus constructing the base line on one side of the pulses. To complete the skeleton of pulses 6500 ohm battery is connected in the even positions to the ring and in the odd positions (except 1 and 3) to the tip. This gives an alternating succession of light positive and negative pulses.

It is now necessary to provide a means to modify these pulses according to the number desired. In order to be able to modify the pulses in the odd quadrants the tip side of the fundamental circuit is connected thru brushes 2 and 4 of cam (D1) to leads which may or may not be grounded in the various positions of the switch depending on the combination of register relays operated. One lead is connected to the tip by cuttings in the first quadrant of each digit and is therefore designated "T1". The other is connected to the tip by cuttings in the third quadrants and is appropriately designated "T3". The tip is also connected in both the first and third quadrants to a lead designated "B". Either one of these leads (which will henceforth be referred to as quadrant leads) or the lead designated "B" may be connected to a lead which is grounded in both the first and third quadrants of a particular digit. This ground digit lead is designated by the letter "G" and a numerical subscript denoting the first of the two consecutive odd positions in which it is connected to ground. Thus the hundreds ground lead would be designated "G5" since it is grounded in positions 5 and 7. Whenever the tip is thus connected to ground the 6500 ohm battery is shorted out in either or both the first or third quadrants.

In the even quadrants, however, there are either light or heavy negative pulses. Therefore in order to modify the skeleton pulse which is light negative, the ring must be connected to 52.5 ohm battery in the even

positions of the switch. These quadrant leads are designated (R2) and (R4) indicating that they are connected to the ring side of the trunk in the second and fourth quadrants respectively of every digit. The battery digit leads are designated by the letter "B" and a numerical subscript indicating the first of the two consecutive even positions of the switch in which they are connected to 52.5 ohm battery. The hundreds battery lead would then be designated "B6" indicating that it is connected to low resistance battery in positions 6 and 8.

The cross-connection between the quadrant and digit leads is determined by the wiring on the register relays shown in fig. 1. Let it be assumed that an "8" is to be sent as the tens digit. Consulting the chart it is found that tens is sent in positions 9 to 12 inclusive and the digit leads are therefore "G9" and "B10". The chart also shows that for this number the relays in the first, second and fourth quadrants are to be operated or the pulses will be positive, heavy negative, ground, and heavy negative. The connections between the quadrant and digit leads will be "T3" to "G9" causing the positive pulse in the third quadrant to be erased and "B to B10" making both negative pulses heavy. With an "8" set up on the tens register relays (T1), (T2) and (T5) are operated. It is readily seen that this combination of relays operated will result in the desired connections.

It should be borne in mind that this explanation does not attempt to present a rigorous exposition of standard practice but merely indicate as simply as possible the methods of circuit operations in the panel system. Such special cases, therefore as the sending of a number greater than 9999, have been omitted in order to simplify instruction.

THE DECODER CONNECTOR

The Decoder Connector circuit is essentially a multi-contact relay per sender and a multi-contact relay per decoder with about fifty connecting common leads for each group of ten senders. Also "R" type relays which perform preference and lock out functions allowing one sender of the group and one decoder to be connected by the common leads at one time.

THE DECODER

The decoding of the office code which was given only cursory mention in the above description of the sender will now be considered in more detail. The operation of the decoder will be divided into three functions.

- (1) Receiving and checking the office code.
- (2) Selecting a route relay corresponding to the office code.
- (3) Transmitting and checking the selections.

Fig. 3 illustrates the first function. When the sender has been connected to the decoder by the connector circuit on a signal over the (ST) lead as previously explained, the armatures of transfer contacts on the office code registers in the sender are connected to the windings of corresponding relays of similar designation in the decoder. The armatures of those relays operated will connect local ground operating the corresponding relays in the decoder. But the closure of the (CK) lead will connect ground thru the back contacts to the armatures of the non-operated relays in the sender causing the remaining registers in the decoder to operate. With all register relays in the decoder operated a chain circuit closes ground to the winding of the (CK1) relay operating it. The (CK1) relay operating prepares a locking circuit in series with (CK2) which meanwhile remains shunted, and opens the ground on (CK) lead causing those relays not needed, to release. The release of these relays opens the chain circuit which held relay (CK2) shunted so that the latter now operates in series with the (CK1) and the office code has been checked. If one of the receiving leads had been open the register relay corresponding to that lead would not have operated so that (CK1) relay could not have operated thus blocking the call. The time measure circuit then counts off five seconds and sends a trouble release signal to the sender which disconnects and makes a second trial, most likely getting another decoder. However if ground had been present on a lead corresponding to a register relay not operated on this call the operation of the (CK1) relay would not have removed the ground from the (CK) lead since the trouble ground would have backed up and held all relays operated. Hence the (CK2) relay would not operate and after five seconds the sender would get a trouble release signal and make a

second trial.

Fig. 4 illustrates the second operation, that of selecting the route relay corresponding to the office code. When relay (CK2) operated it grounded three leads. The first one under control of the (A) register group operates an (H) multi-contact or gang relay whose numerical designation corresponds to the digit registered. Thus if relays (A1), (A2) and (A5) are operated relay (H8) will operate. The (H8) relay will close 100 contacts causing the windings of 100 route (R) relays numbered 800-899 to be connected to one hundred common leads terminating on contacts on the (T) relays.

The second lead which the (CK2) relay grounded will operate one of the (T) relays depending on the setting of the (B) register group. Here again the numerical designation of the relay operated corresponds to the digit recorded on the (B) register. The operation of the (T) relay closes ten of the aforementioned hundred common leads to contacts on the (C) register relays. If (T7) has been operated leads number 70 to 79 will be connected to the (C) relays.

The (CK2) relay also closed ground to a lead which is connected to one of the above mentioned ten leads the particular lead depending upon the digit set up. Thus if relays (C1) and (C5) are operated lead number six is grounded which goes thru a contact on (T7) and (H8) to operate route relay #876 it being assumed that that is the number corresponding to the office code. In this way any one of 1000 route relays may be operated.

The next step is the transmitting and checking of the office selections. The route relay, shown on fig. 5, having been operated grounds six leads which terminate on the cross connecting frame and are designated respectively by the letters "CL", "DB", "DG", "OB", "OG" and "CR" and a common number corresponding to the (R) relay with which they are associated. These six leads are cross connected to terminals wired to the primary or secondary windings of the transmitting relays corresponding to the leads. The "OG" lead for instance would be connected to either the primary or secondary winding of any of the (OG) relays from (OGO) to (OG5) depending on the selection desired and according to the table shown on the figure. Thus if

Office Group seven is desired the "OG" lead is connected to the primary winding of (OG2) relay. It should be noted that by connecting to the primary instead of the secondary the selection is increased by five and that (OG5) relay is used for grounding the (SO) lead which gives the sender a skip office signal meaning that no office selections are required.

The primary windings of the transmitting relays (OG0) to (OG4) are each in series with (OGP) relay while the secondary windings are in series with (OGS) relay. Both (OGP) and (OGS) relays receive battery thru the (OGX) relay. For any selection either (OGP) or (OGS) will operate in series with the transmitting relay. The (OGX) relay, however, will not operate except when two windings in the transmitting group are grounded. With (OGX) operated a ground is placed on lead (X) operating relay (X) which sends a trouble release signal to the sender causing it to disconnect and make a second trial. In this way the windings of the transmitting relays are checked for false crosses.

In order to transmit the selections for any group of transmitting relays a varying number of transmitting leads are grounded thru the windings of the checking relays which for the group under discussion are designated (OGA), (OGB) and (OGC). The rest of the leads are connected to the (X) lead so that a false ground will result in a second trial. If any of the working leads are open or grounded the associated checking relay will not operate and the sender fails to get a release signal. In this case the timing circuit will send a trouble release signal causing a second trial.

Let it be assumed that an Office Group of three is desired. In this case the (OG) lead on the (R) relay is connected to the secondary of the (OG3) relay causing it to operate in series with the (OGS). Lead (OG1) will then be connected to 200 ohm ground thru winding of relay (OGC) causing it to operate in series with (OG1) relay in the sender. Lead (OG2) is connected thru the 200 ohm winding of (OGB) relay to ground causing (OGB) to operate in series with (OG2) relay in the sender. Leads (OG4), (OG5) and (SO) are connected to lead (X) to check for false ground.

With the above relays operated ground from the other five similar

groups of transmitting and checking relays goes thru the make contacts on (OGC), (OGB) and (OGS) relays to operate the (RL) relay which grounds the (RL) lead to the sender causing the sender to lock up its selection registers and release the decoder.

The time required for translation due to the decoder alone is equal to the sum of the following relay operations

- (1) Simultaneous operation of all register relays
- (2) Operation of (CK1) relay
- (3) Simultaneous release of unused register relays
- (4) Operation of (CK2) relay
- (5) Simultaneous operation of an (H) and a (T) relay
- (6) Operation of a route relay
- (7) Simultaneous operation of transmitting relays
- (8) Simultaneous operation of checking relays
- (9) Operation of (RL) relay

Added to the above times are the times of connection and disconnection due to the sender and connector circuits. Altogether the total time required for decoding is about 0.3 second, which is remarkable when it is considered how thoroughly the decoder performs its duties.

THE TROUBLE INDICATOR

In the foregoing paragraphs there was mention of trouble being encountered resulting in a trouble release signal being transmitted to the sender. In case of trouble it is important that the maintenance operator be informed of its existence and given as much information as possible of its nature in order to expedite the work of locating and correcting it. Since there are only six decoders in an office it is desirable to keep them in service as much as possible. In order then to keep the decoders in service and also to record troubles encountered the trouble indicator has been developed. When a decoder gets into trouble the trouble indicator receives a signal causing it to connect to the decoder and record the following information about the call.

1. The number of the decoder
2. The number of the sender
3. The number of the office code
4. The lead or leads on which trouble occurred

The maintenance operator will hear an alarm causing him to record the above information and release the indicator so as to make it available for further service. Analyzing the trouble he will test either the sender or the decoder or both if necessary in order to reproduce and locate it.

NOTE: It should be noted that in certain cases the relays as shown in the figures carry spring combinations which cannot be obtained on a single "R" type relay but represent the switching of leads which must be obtained.

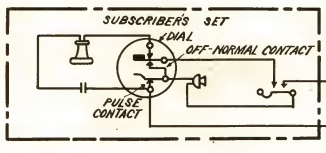

DIAL PULSE CONTROL CIRCUIT

PULSES RECEIVED	DIAL PULSE	OPERATED REGISTER RELAYS
1	(P1), (P1')	(1)
2	(P2), (P2')	(2)
3	(P2), (P2'), (P3), (P3')	(1), (2)
4	(P4), (P4')	(4)
5	(P5), (P5')	(5)
6	(P1), (P1'), (P5), (P5')	(1), (5)
7	(P2), (P2'), (P5), (P5')	(2), (5)
8	(P2), (P2'), (P3), (P3'), (P5), (P5')	(1), (2), (5)
9	(P3), (P3'), (P4), (P4'), (P5), (P5')	(1), (5)
10	(P4), (P4'), (P3), (P3'), (P4), (P4'), (P5), (P5')	(1), (4), (5)

DIAL PULSE COUNTING CIRCUIT

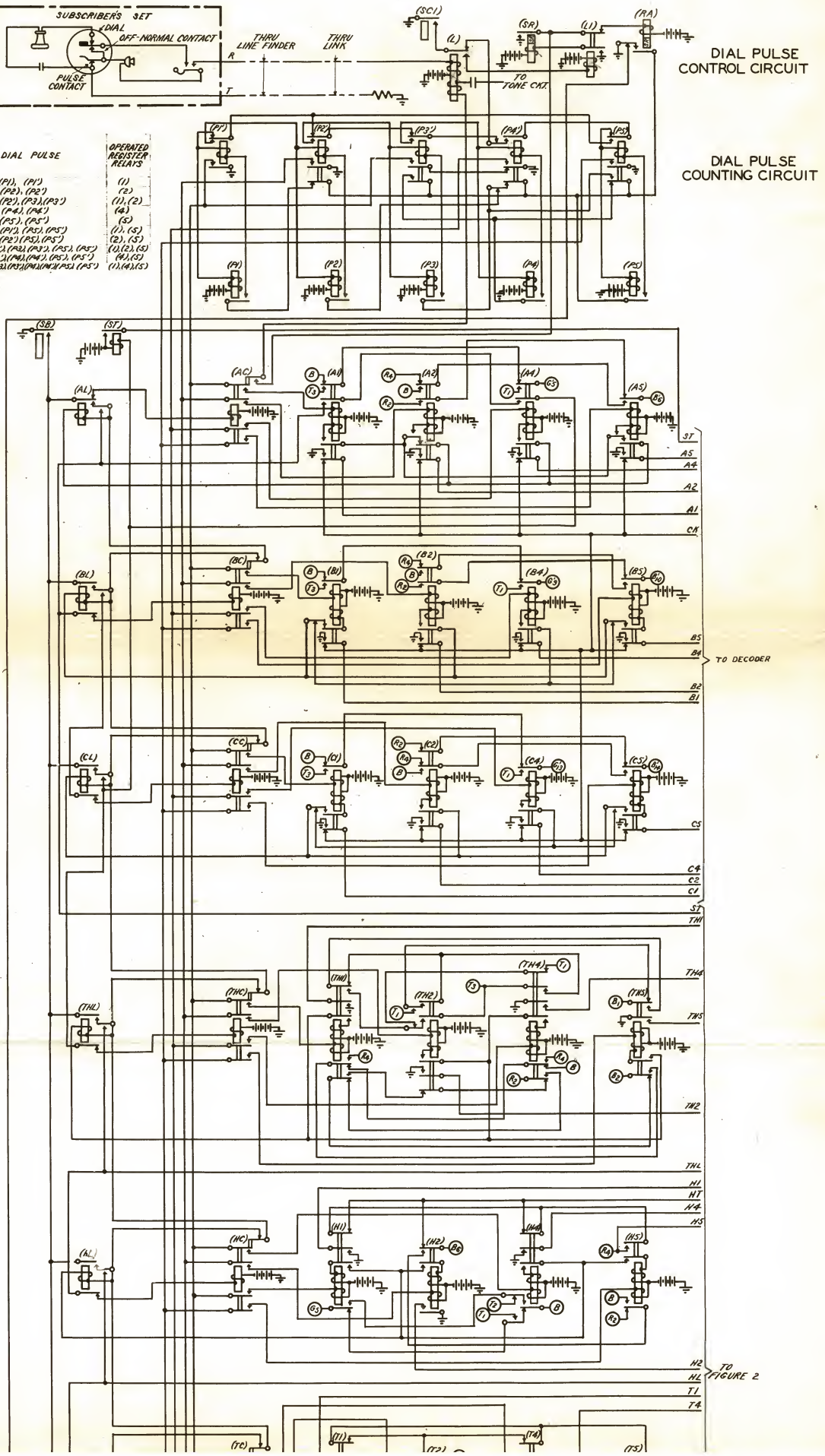

TO DECODER

TO FIGURE 2

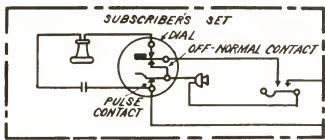

DIAL PULSE CONTROL CIRCUIT

PULSES RECEIVED	DIAL PULSE	OPERATED REGISTER RELAYS
1	(P1) (P1')	(1)
2	(P2) (P2')	(2)
3	(P2) (P2') (P3) (P3')	(1) (2)
4	(P4) (P4')	(4)
5	(P5) (P5')	(5)
6	(P1) (P1') (P5) (P5')	(1) (5)
7	(P2) (P2') (P5) (P5')	(2) (5)
8	(P2) (P2') (P3) (P3') (P5) (P5')	(1) (2) (5)
9	(P3) (P3') (P4) (P4') (P5) (P5')	(1) (3) (5)
10	(P4) (P4') (P5) (P5') (P3) (P3')	(1) (4) (5)

DIAL PULSE COUNTING CIRCUIT

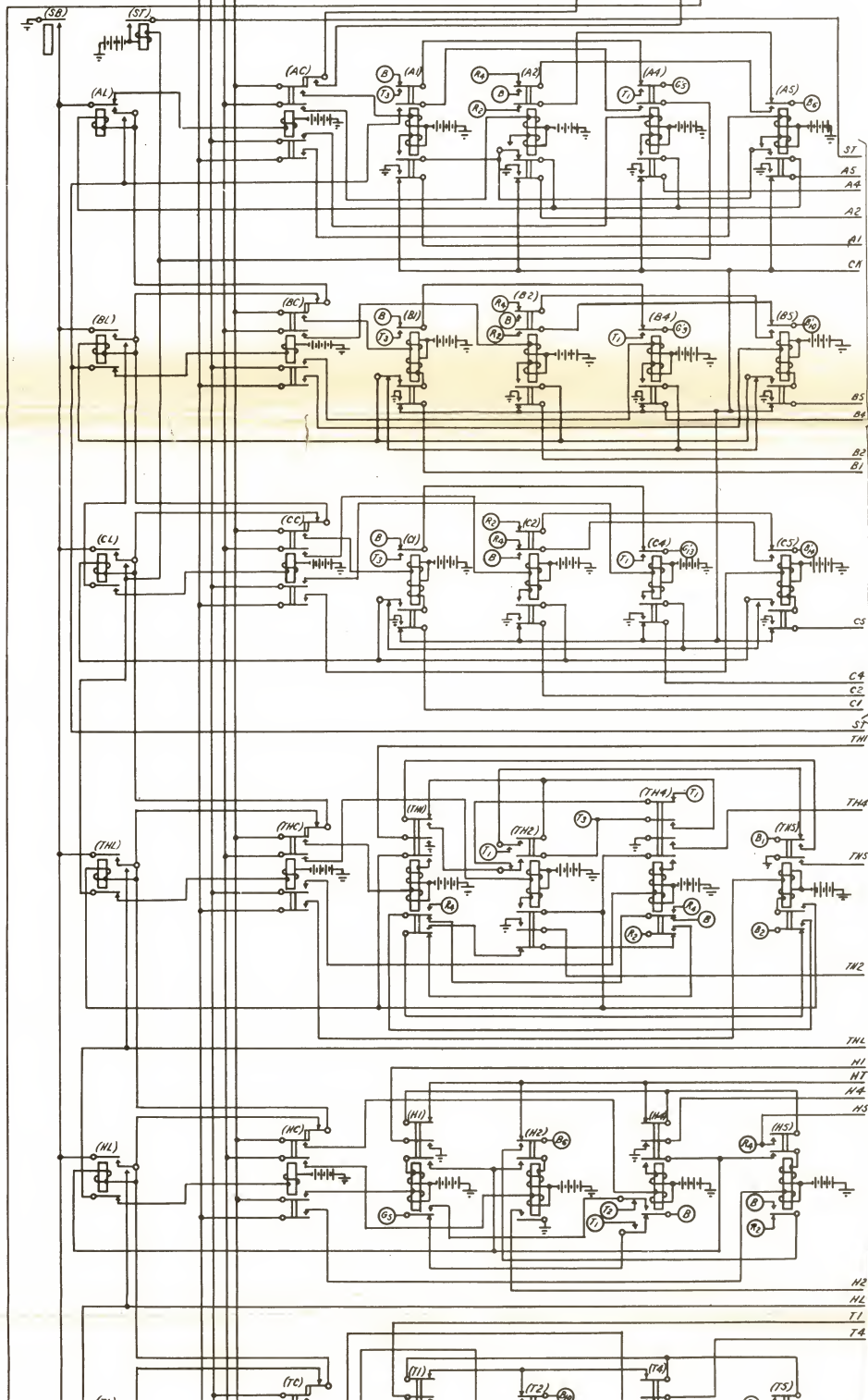

TO DECODER

TO FIGURE 2

SENDER

DECODER

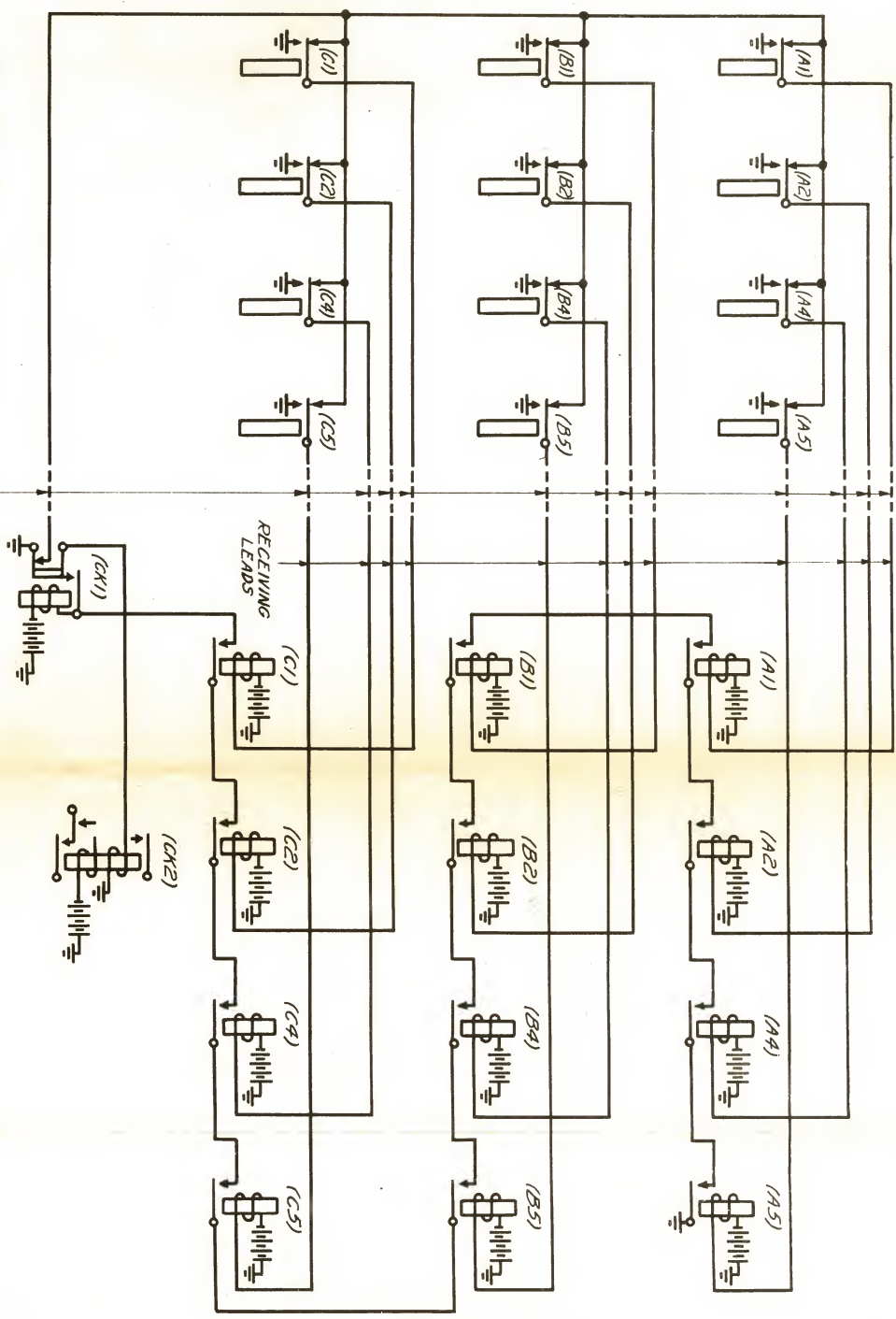

THRU DECODER CONNECTOR CIRCUIT
RECEIVING AND CHECKING THE OFFICE CODE REGISTER SETTING
FIG. 3

LEADS 0-1000 CONNECTED TO WINDINGS OF ROUTE RELAYS

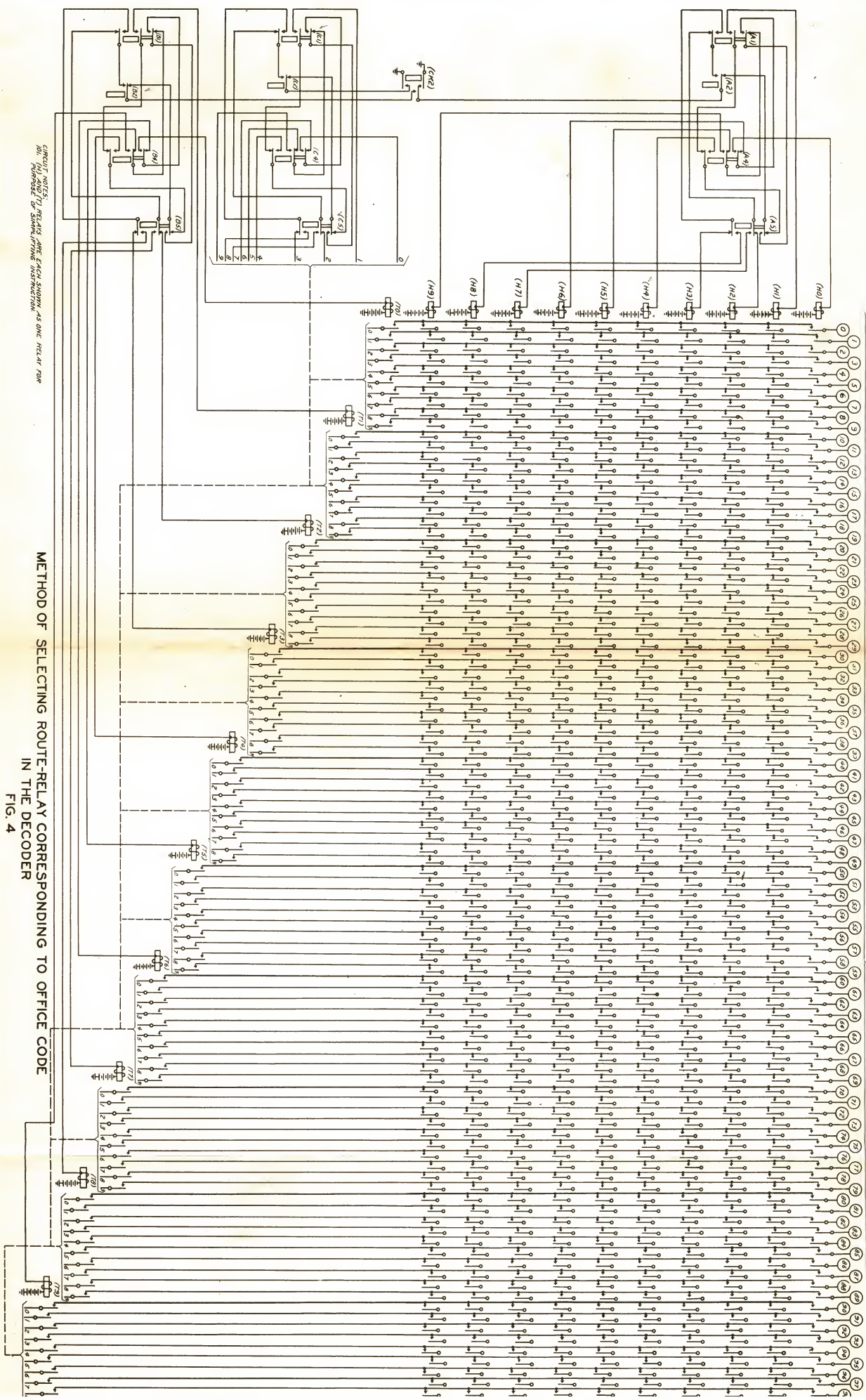

METHOD OF SELECTING ROUTE-RELAY CORRESPONDING TO OFFICE CODE
IN THE DECODER
FIG. 4

CIRCUIT NOTES:
101. (M) AND (L) RELAYS ARE EACH SHOWN AS ONE RELAY FOR

OFFICE GROUP	LEADS GROUNDED	TRANSMITTING RELAY	WINDING TO WHICH (OG) LEAD ON (R) RELAY IS X-CONN.	CHECKING RELAYS OPERATED
0		(OG0)	S	(OGS)
1	OG1	(OG1)	S	(OGS)(OGB)
2	OG2	(OG2)	S	(OGS)(OGB)
3	OG1, OG2	(OG3)	S	(OGS)(OGB)(OGC)
4	OG4	(OG4)	S	(OGS)(OGB)
5	OG5	(OG0)	P	(OGP)(OGA)
6	OG1, OG5	(OG1)	P	(OGP)(OGA)(OGB)
7	OG2, OG5	(OG2)	P	(OGP)(OGA)(OGB)
8	OG1, OG2, OG5	(OG3)	P	(OGP)(OGA)(OGB)(OGC)
9	OG4, OG5	(OG4)	P	(OGP)(OGA)(OGB)
SO	SO	(OG5)	S	(OGS)(OGB)

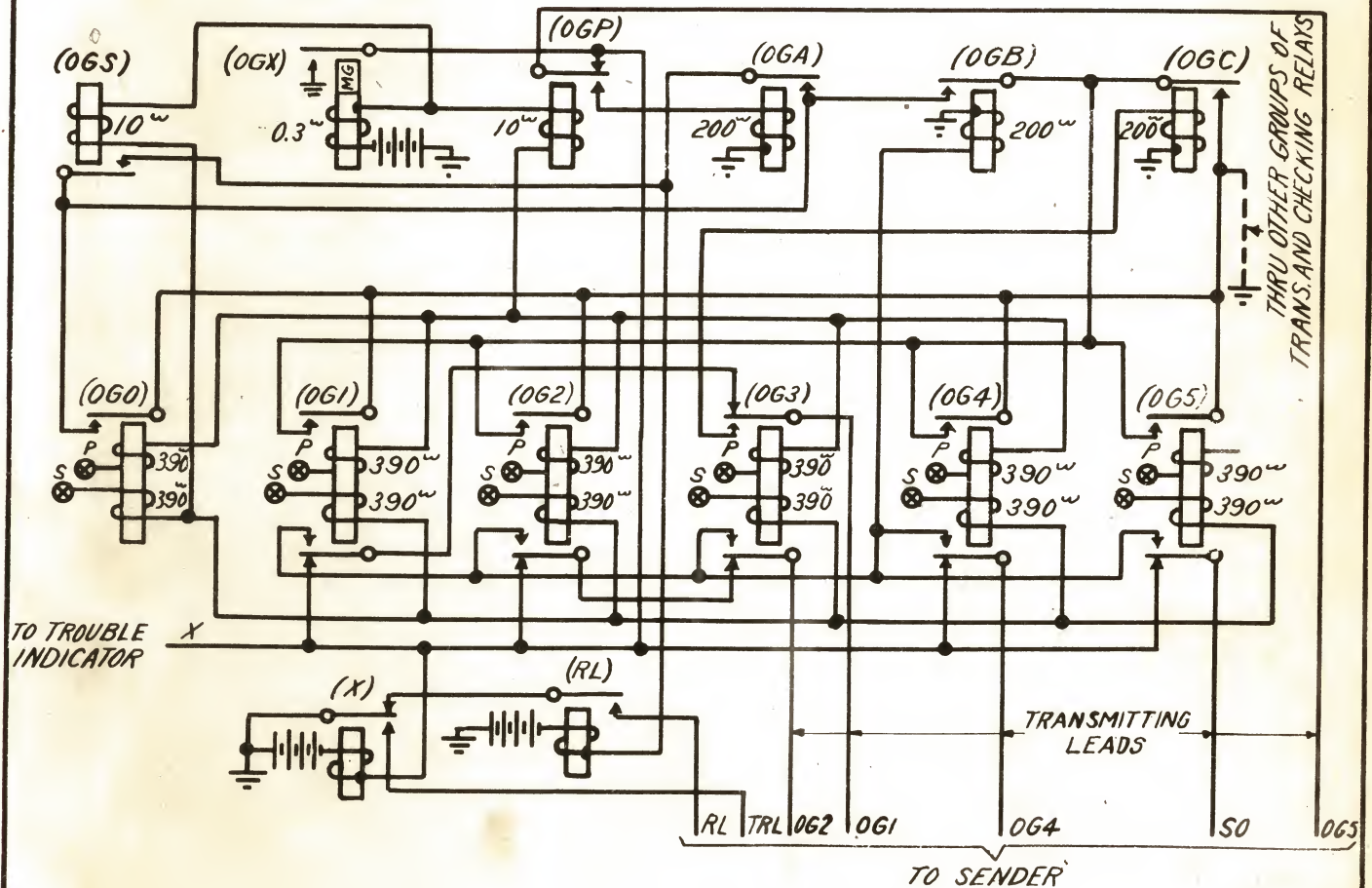
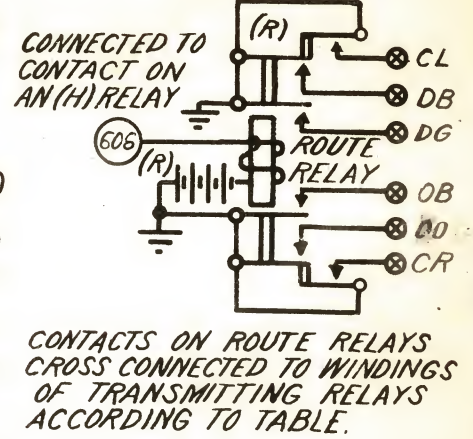

METHOD OF TRANSMITTING AND CHECKING SELECTIONS IN THE DECODER

FIG. 5

OFFICE GROUP	LEADS GROUNDED	TRANSMITTING RELAY	WINDING TO WHICH (OG) LEAD ON (R) RELAY IS X-CONN.	CHECKING RELAYS OPERATED
0		(OG0)	S	(OGS)
1	OG1	(OG1)	S	(OGS)(OGB)
2	OG2	(OG2)	S	(OGS)(OGB)
3	OG1, OG2	(OG3)	S	(OGS)(OGB)(OGC)
4	OG4	(OG4)	S	(OGS)(OGB)
5	OG5	(OG0)	P	(OGP)(OGA)
6	OG1, OG5	(OG1)	P	(OGP)(OGA)(OGB)
7	OG2, OG5	(OG2)	P	(OGP)(OGA)(OGB)
8	OG1, OG2, OG5	(OG3)	P	(OGP)(OGA) (OGB)(OGC)
9	OG4, OG5	(OG4)	P	(OGP)(OGA)(OGB)
S0	S0	(OG5)	S	(OGS)(OGB)

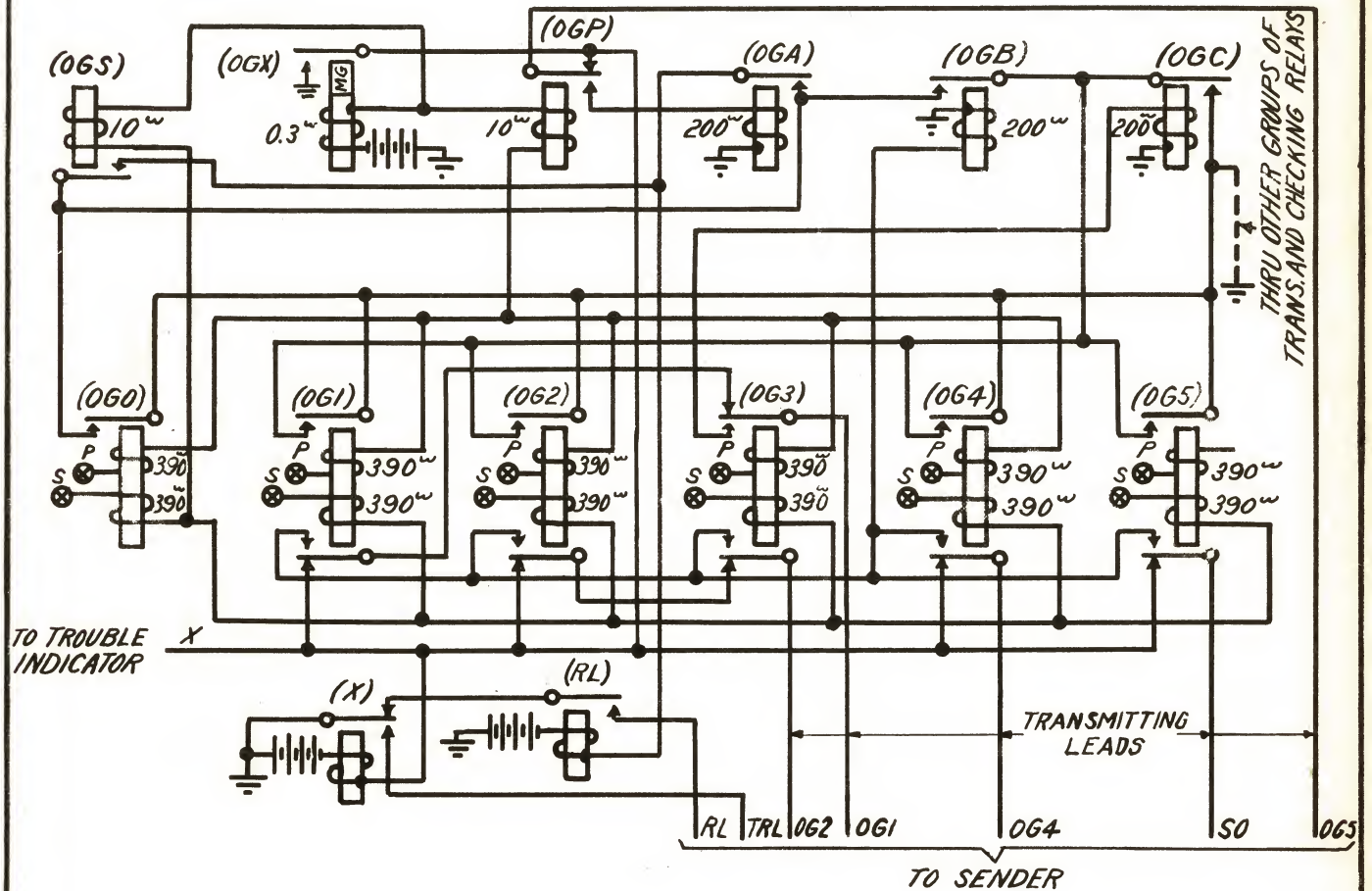
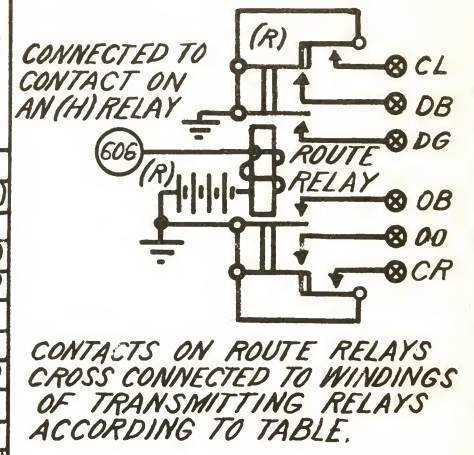

METHOD OF TRANSMITTING AND CHECKING SELECTIONS IN THE DECODER
 FIG. 5

1- NORMAL
 5- START TANDEM P.C.I.
 17- START DIRECT P.C.I.
 ALL CAMS CUT ON A 20 POS.
 BASIS.
 SWITCH MAKES TWO
 REVOLUTIONS FOR EACH CALL.

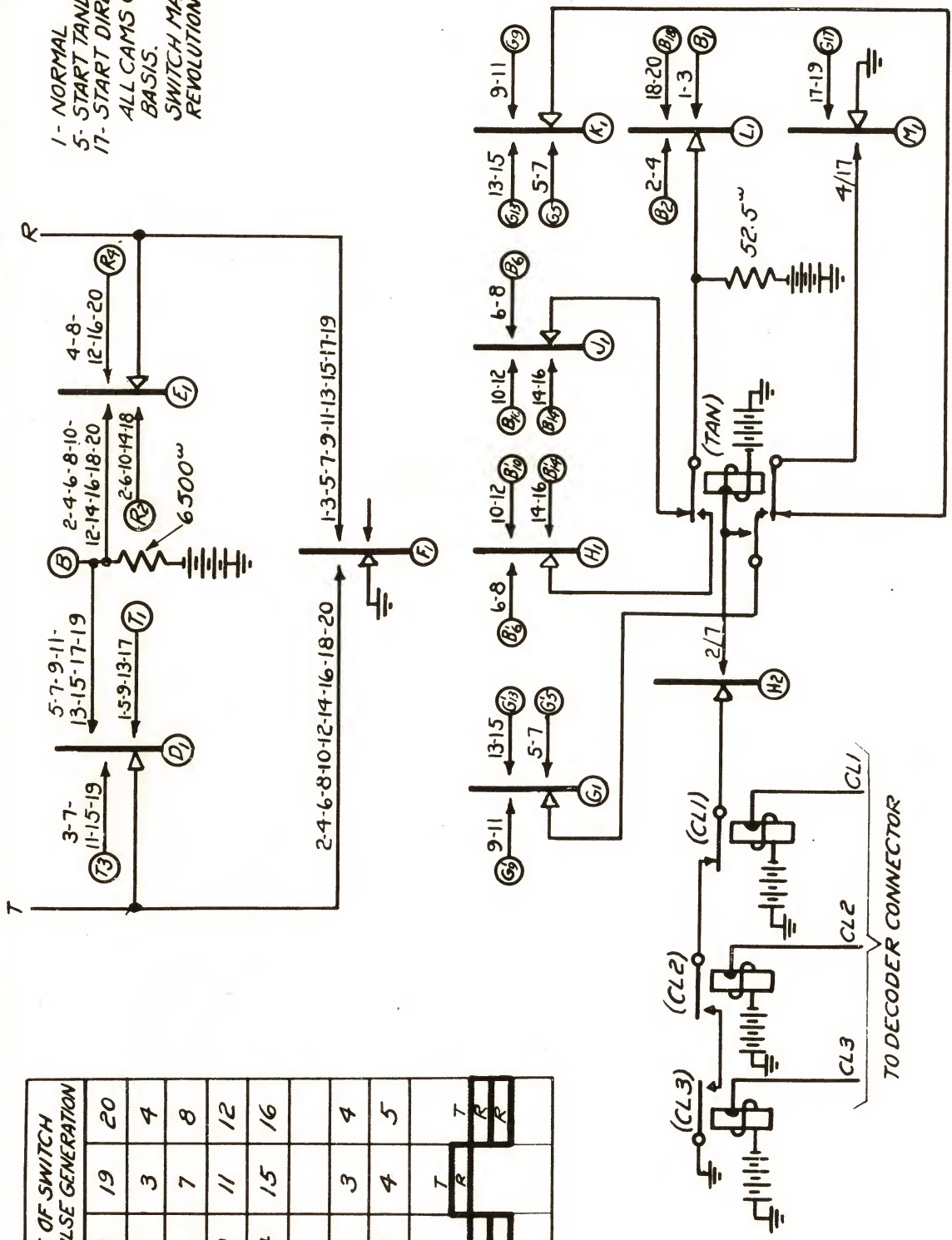

DIGIT	POSITIONS OF SWITCH DURING PULSE GENERATION			
	17	18	19	20
ST				
TD	1	2	3	4
H-TH	5	6	7	8
T-TT	9	10	11	12
U-TU	13	14	15	16
QUAD.	1	2	3	4
RELAY	1	2	4	5
+ 0 -	T R	T R	T R	T R

SIMPLIFIED P.C.I. IMPULSE SWITCH
 FIG. 6

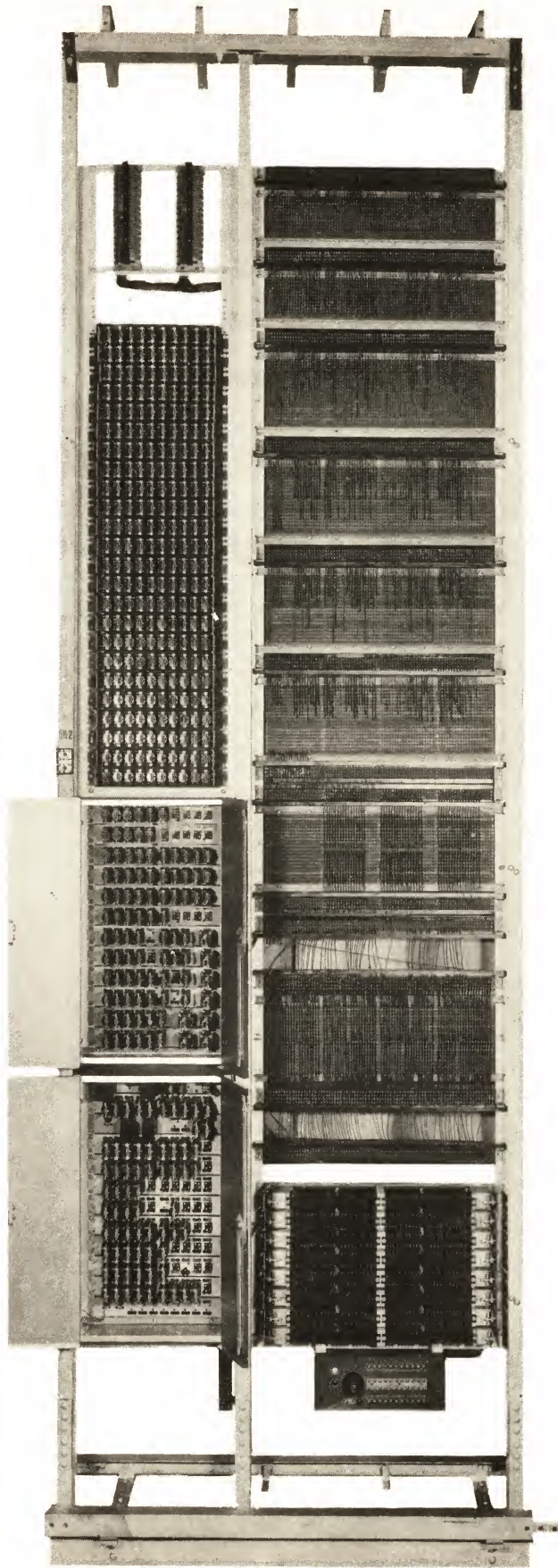
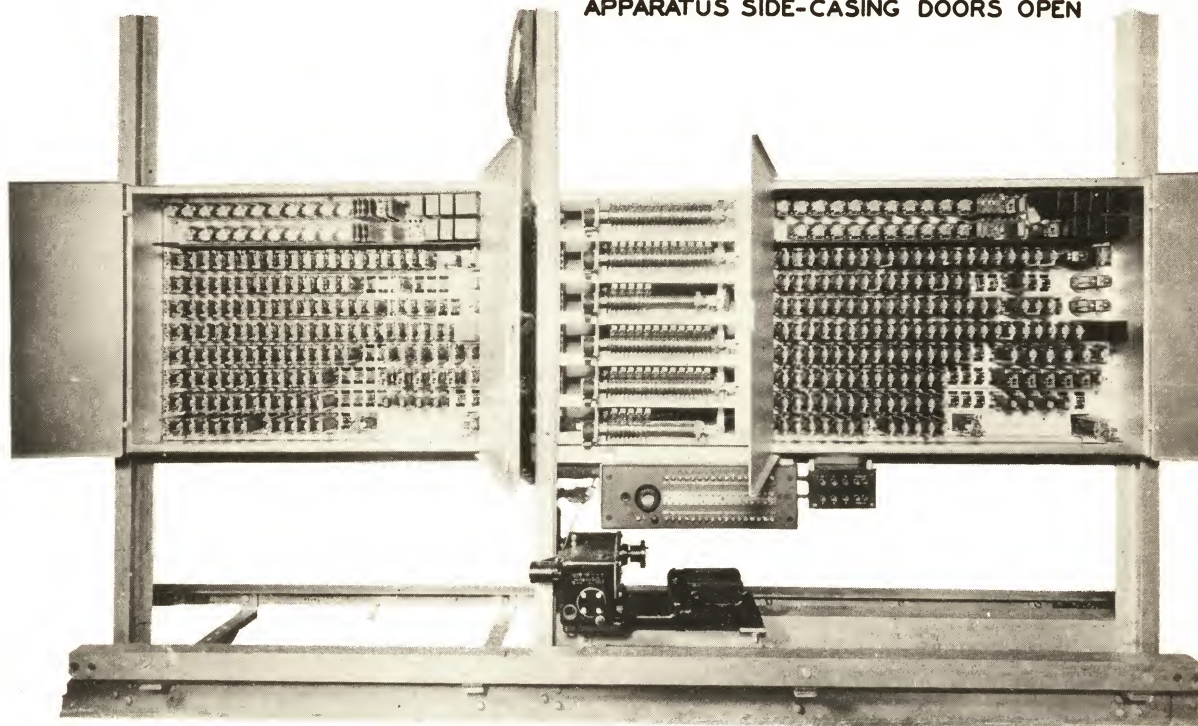

FIG. 7
3-DIGIT DECODER FRAME
APPARATUS SIDE-COVERS REMOVED

SHOWING ONE UNIT MOUNTED
APPARATUS SIDE-CASING DOORS OPEN



SHOWING ONE UNIT MOUNTED
APPARATUS SIDE-CASING DOORS CLOSED

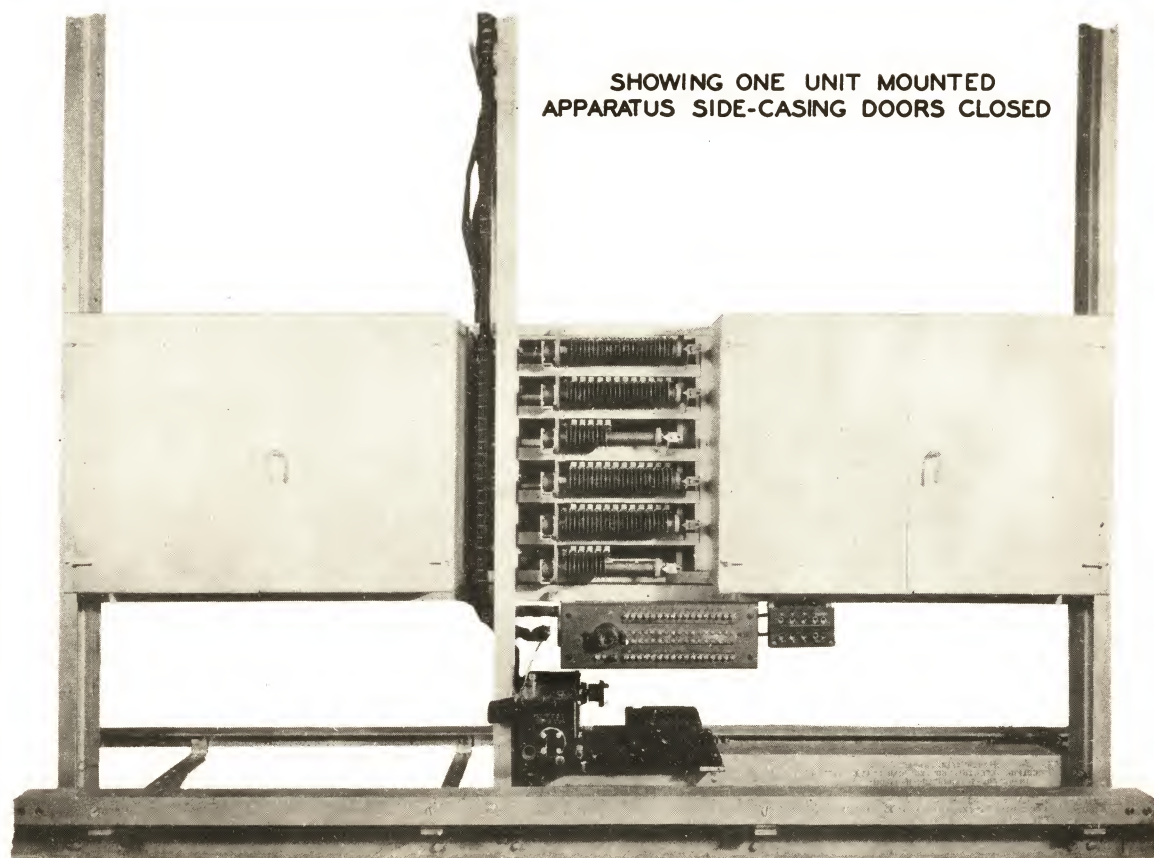

FIG. 8
3-DIGIT SUBSCRIBERS SENDER FRAME
UNIT TYPE FOR USE WITH DECODER

Photograph No. 28885 - Front View of Lineup of Frames - Traffic Originator - Decoder Test
Sec. A & Sec. B, and Decoders 1, 2, & 3 - Left to Right - Laboratories Installation of Decoder
Equipment for 3 Digit Offices - Panel System - Windsor Office No. 2 - Brooklyn, N.Y. -
New York Telephone Company - Order 32794 - Case 35580 - Spec. E-32794-492 - 9/9/27



28885

FIG. 9
DECODER FRAMES

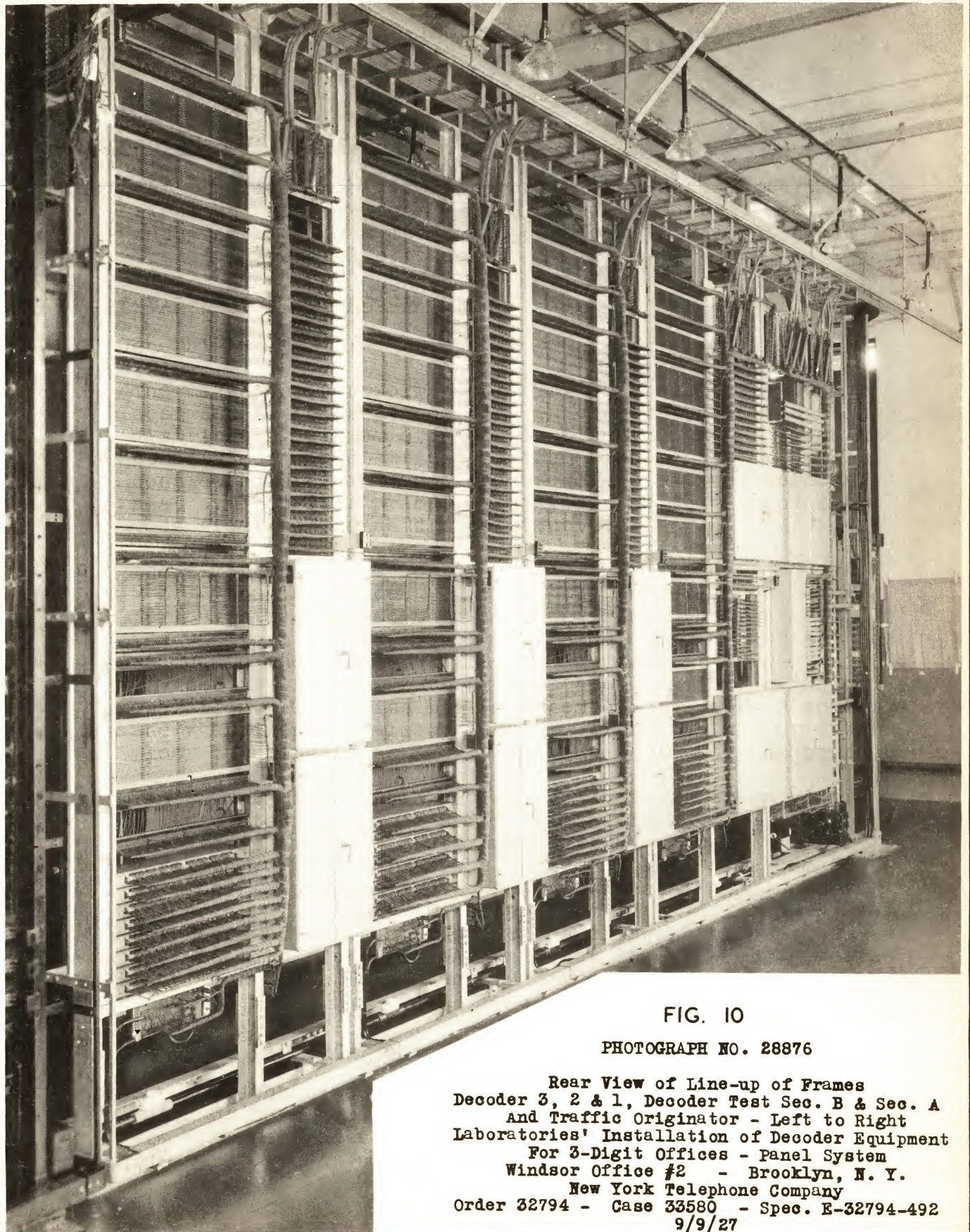
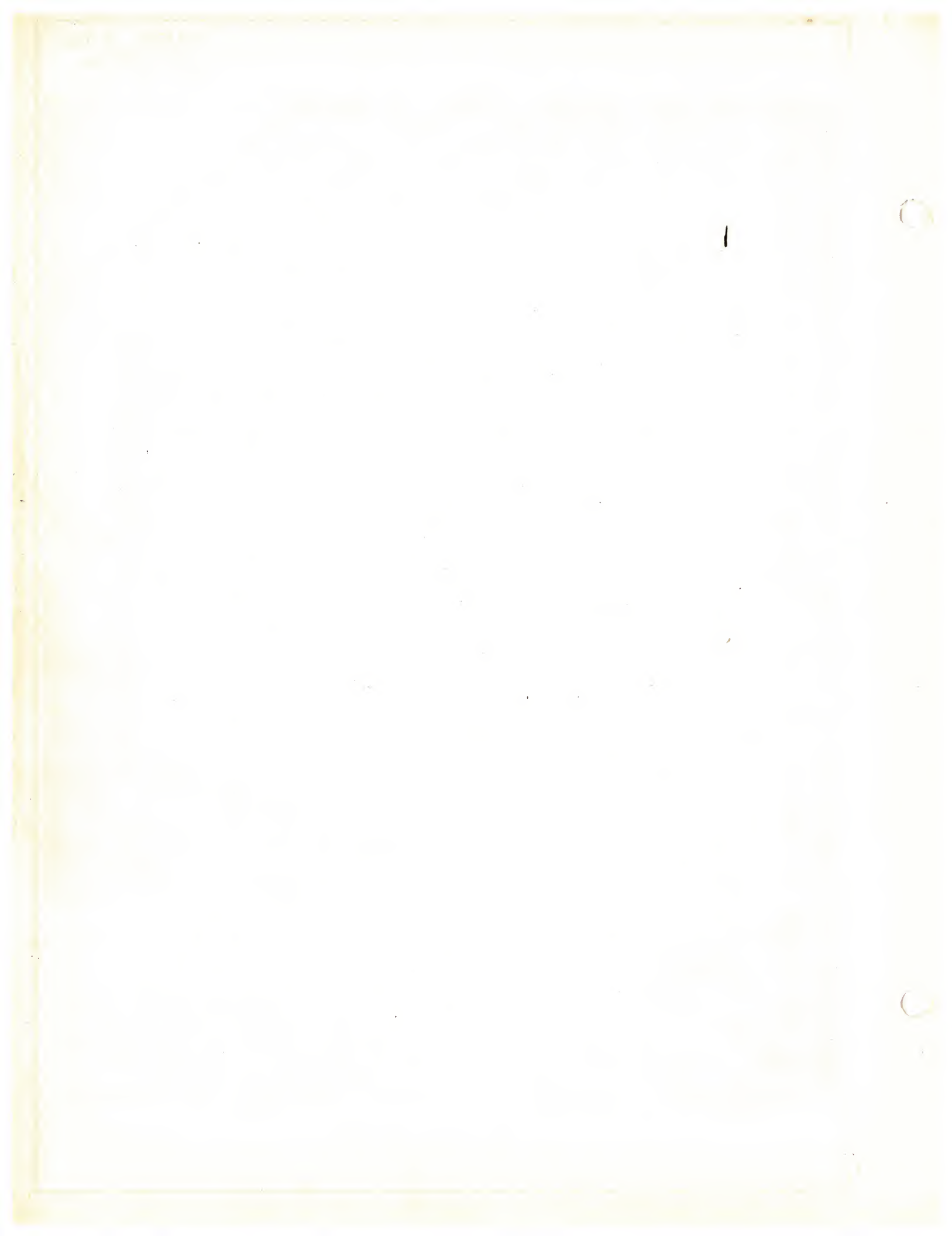

FIG. 10

PHOTOGRAPH NO. 28876

Rear View of Line-up of Frames
Decoder 3, 2 & 1, Decoder Test Sec. B & Sec. A
And Traffic Originator - Left to Right
Laboratories' Installation of Decoder Equipment
For 3-Digit Offices - Panel System
Windsor Office #2 - Brooklyn, N. Y.
New York Telephone Company
Order 32794 - Case 33580 - Spec. E-32794-492
9/9/27



TANDEM OPERATIONS

In many cases it is not economical to provide direct trunks between one office and all other offices in the area served by a panel system, in which case traffic to a group of offices is routed over a common group of trunks to a tandem point. "Tandem" ordinarily means "in series", and, altho all local and interoffice calls originating or terminating in a panel office employ various equipment and circuit units in series, the term "tandem" as used in this chapter does not include such connections. It applies only to those connections or that traffic which is routed out of the originating office over trunks which terminate at an intermediate office, at which some manual or mechanical operation is necessary in selecting a trunk from the intermediate to the terminating office, over which the call can be completed.

Tandem trunks may be selected by district selectors in the originating office and terminate on 2-wire office selectors at the tandem point; or they may be selected by either a district or a 3-wire office selector in the originating office and terminate, - (1) as tandem RCI trunks in a Manual Tandem office, (2) as tandem RCI trunks in a Semi-Mechanical Tandem office, or (3) as tandem trunks connected to tandem district selector circuits in a mechanical tandem office. Figure 1 illustrates the equipment involved in completing the various types of tandem connections. Since calls completed thru Manual Tandem offices have been considered in the chapter on "Relay Call Indicator" equipment no further consideration will be given to the equipment and operations involved in handling this traffic.

Two-Wire Office and Repeating Incoming Selector Circuits

The office selector circuits which have been considered in the previous chapters, were 3-wire circuits located in the same building with the district frames to whose multiple banks they were connected. When it is desirable to use a common group of trunks to a tandem point in reaching a group of offices, none of which are so far distant from the originating office as to prevent the use of direct trunks, two-wire office selectors would be installed at the tandem point, thus permitting completion of the call under direct control of the sender in the

originating office. A two-wire office selector circuit is made to test busy on the district multiple sleeve terminal as soon as it has been selected but can not be controlled over the sleeve conductor as is the 3-wire office selector. Having been selected on a call the two-wire office selector circuit makes brush and group selections under control of the sender in the originating office, selects an idle trunk in the selected group and advances into the "Selection Beyond" position in which it remains until Incoming and Final Selections are completed, if the call terminates in another panel office, or until RCI pulses have been transmitted from the originating sender to an RCI control circuit if the call terminates at an RCI position in a manual office. In either case it is necessary that the two-wire office selector circuit know when to advance into the talking position. On a mechanical class call the reversal of current in the fundamental circuit by the incoming selector circuit when final selections have been completed operates a polarized relay, in the two-wire office selector, which is cut-in on the "Ring" side of the fundamental circuit in the "Selection Beyond" position. On an RCI class call the originating sender transmits a final heavy positive pulse, after all the pulses corresponding to the office code and number have been transmitted, so as to operate the polarized relay in the two-wire office selector. In the talking position the trunk incoming to the tandem point is connected to the trunk outgoing from the tandem point thru windings of a supervisory relay in the two-wire office selector circuit. This relay operates when the talking circuit is established, and its release, when the district returns to normal, causes the return of the two-wire office selector circuit to normal. Two-wire office selector circuits are provided with a "timing-out" feature for advancing the switch if the circuit fails to complete selections, becomes "Stuck" in the "Selection Beyond" position, or fails to return to "Normal" after the switch has been advanced beyond the "Talking" position.

The use of two-wire office selectors extends the area within which calls may be completed under control of the originating sender circuit; but where the trunk loop between the originating and terminating offices exceeds the capability of the regular incoming and final selector circuits, it is necessary to use "Repeating Incoming Selector" circuits. "Repeating Incoming Selector"

circuits are equipped with a special commutator, and with an (L) relay of such extreme sensitivity that it cannot perform the trunk hunting function as does the (L) relay in a regular incoming selector circuit. In order that regular final selector circuits can be used on calls through repeating incomings, the repeating incoming is arranged so that the (L) relay in the incoming circuit also controls final selections, the ground pulses from the final commutator segments being repeated by the incoming to the sender circuit. With these exceptions Repeating Incoming Selector circuits operate in a similar manner to regular incoming selector circuits.

The use of Repeating Incoming Selector Circuits is not limited to traffic which is routed thru 2-wire office selectors but it is more likely that trunk loops will exceed the capability of the regular incoming selectors on traffic which is routed thru 2-wire office selectors than on traffic which is not so routed. "Repeating Incoming Selector" circuits have also been developed for use on calls incoming from key indicator manual offices.

Full Mechanical Tandem

On calls which are completed thru a full mechanical tandem office the trunks selected under control of the originating subscriber's sender circuits connect to tandem district selector circuits in the tandem office. As soon as the trunk has been selected on a particular call the tandem district selector circuit to which this trunk connects is selected by a link circuit and connected to an idle full mechanical tandem sender. The present link circuits are of the rotary link type, both the trunk finder and sender selector consisting of 1203 type selectors. The link circuits are allotted in rotation by an allotter which consists essentially of a sequence switch and a number of relays. When the trunk has been "cut thru" to the tandem sender, the originating subscriber's sender transmits such RCI pulses over the trunk as are required to cause the operation of combinations of register relays in the tandem sender corresponding to the office code and number of the called line.

Since a tandem point is used in completing calls between offices in a local area and points suburban to this area, an additional set of office codes is used for the suburban destinations. To avoid reducing the number of letter

codes available for local office code use suburban points are given 3-digit numerical codes, at least one of the 3 digits being either an "0" or a "1". (These codes are the same ones used by the "A" position operators in completing suburban toll traffic even though not routed thru a tandem point.) Since none of the letters in the local office codes correspond to either an "0" or a "1", the full mechanical tandem sender can distinguish between letter codes and numerical codes as recorded on the tandem code register relays by the incoming RCI pulses. An additional set of translator frames is provided for the translation of the numerical codes and each sender has access to translator brush rods on both letter code translator frames and numerical code translator frames. On each call the sender uses a translator which corresponds to the kind of tandem code registered. Three-digit translation is then made as controlled by the combination of the tandem code register relays which have been operated. The tandem sender causes the tandem district (and office selector when used) to make such selections as are required. When the called office is a panel type office the tandem sender completes the connection as a mechanical class call, and when the called office is manually operated the call is completed as an RCI class call. A 3-wire or 2-wire office selector circuit may be used in completing the call and in some cases the call may be routed to a second tandem point. The tandem district circuit repeats supervision between the calling and called offices. Tandem operation is not limited by the capability of the panel type selector circuits when the tandem points are equipped with tandem senders, but is limited by the standard of transmission to be maintained, and by the ability to arrange for the repeating of supervision at the tandem points between the calling and called offices.

Semi-Mechanical Tandem Office

The present Metropolitan Toll office is equipped for both semi-mechanical tandem and full mechanical tandem operation. Calls incoming from manual offices over call circuit or straightforward trunks are handled at semi-mechanical positions which are similar in some respects to Cordless B positions and in some respects to semi-mechanical type panel system "A" positions. An incoming trunk terminates on a cordless district circuit which is selected by the trunk

finder of a link circuit and connected to an idle sender circuit, the sender being selected by the sender-selector part of the link. The link circuits, which are of the panel link type, are allotted in rotation by an allotter circuit which consists essentially of a sequence switch and a number of relays. The key set provided is similar to the key set at a semi-mechanical type panel system "A" position except that the office code keys are replaced by co-ordinate keys and a chart which informs the operator what co-ordinate keys (one vertical and one horizontal) should be depressed, in addition to the numerical keys, to reach any particular office. Two key control circuits are provided for controlling registration in the sender according to the keys depressed. The sender circuit makes translation in a similar manner to that in which a subscriber's three-digit sender makes translation. The connection is completed under control of the sender as required for the class of call involved.

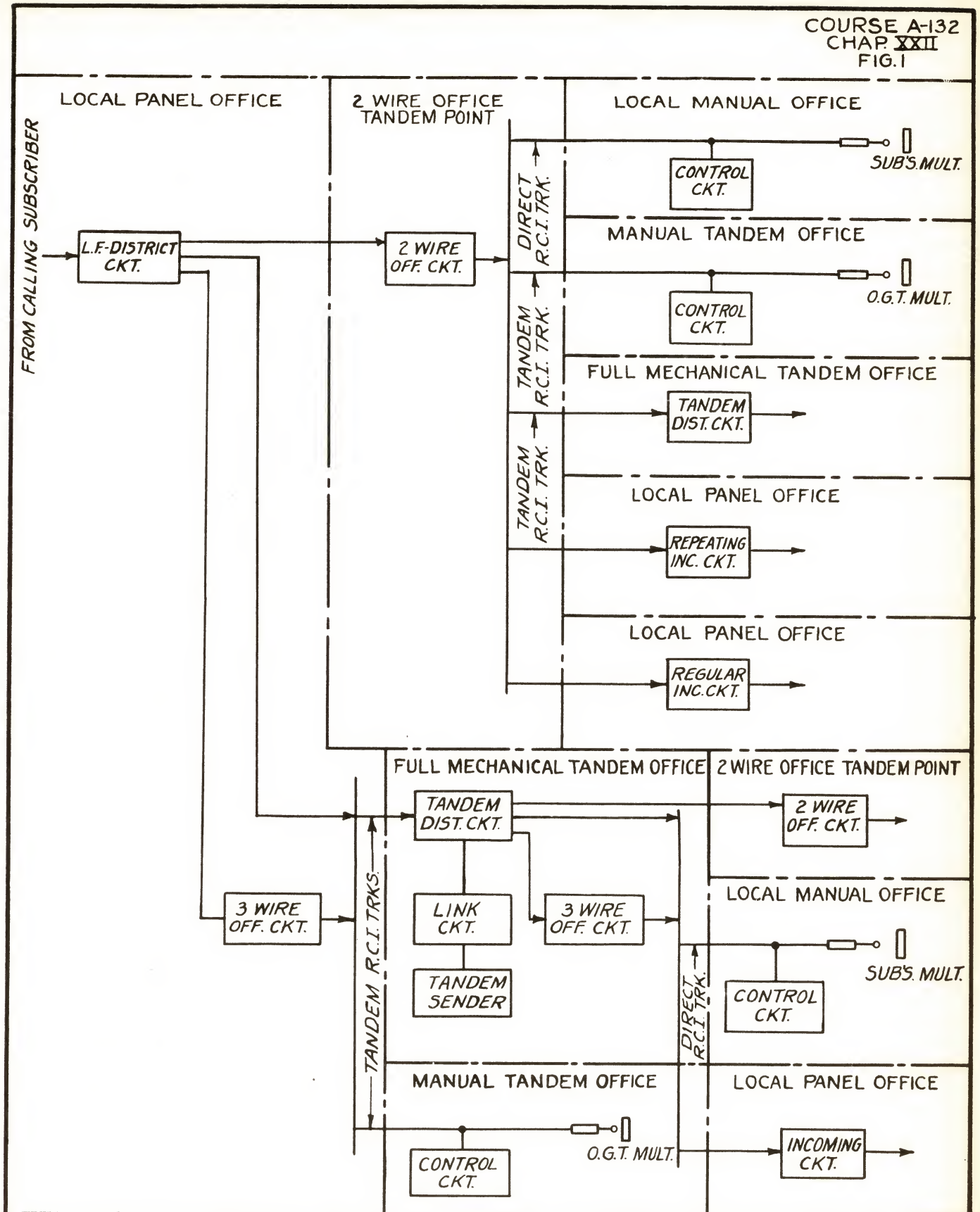

CALLS COMPLETED OVER TANDEM TRUNKS
 THRU MANUAL AND FULL MECHANICAL TANDEM OFFICES
 AND THRU TWO WIRE OFFICE TANDEM POINT
FIG. I

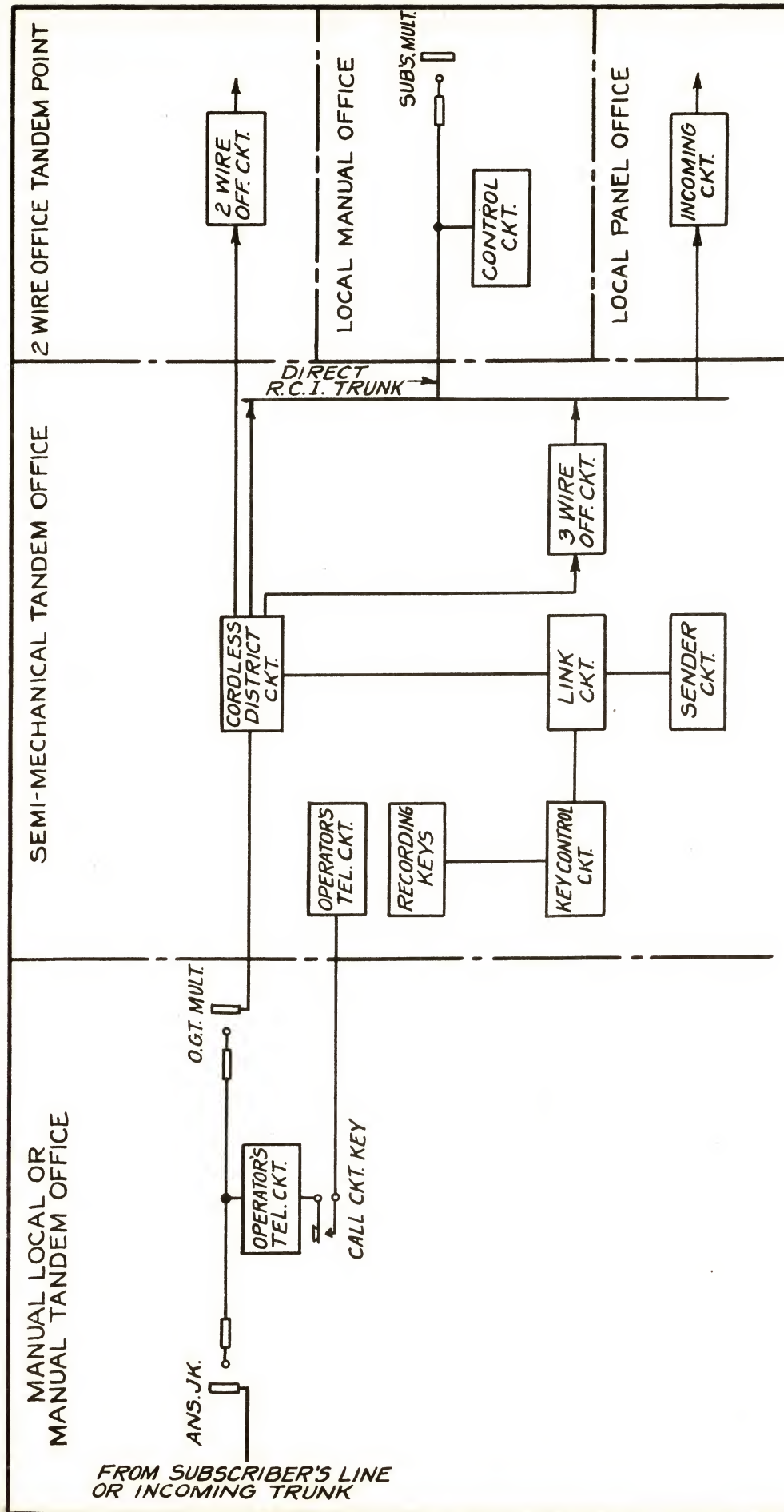

CALLS THRU SEMI-MECHANICAL TANDEM OFFICE
FIG. 2

CHAPTER XXIII

MISCELLANEOUS FRAME AND DESK EQUIPMENT

As in the manual office, so too in the Panel system office, it is necessary to provide a number of miscellaneous desks and frames. Some of this equipment is similar to that used in a manual office. Equipment, which is used for maintenance and the clearing of trouble, includes an outgoing trunk test desk, sender monitor positions, chief switchmen's desk, switchmen's desks, local test desk, repair clerk's desk, and desk sender frames; that used for the automatic indication of trouble or irregular operation includes floor alarm boards, aisle pilot lamps and alarm bells; and that used for traffic supervision includes a chief operator's desk, assistant-chief operator's desk, and a service observing desk. A traffic register rack equipped with message registers is furnished for the automatic registration of traffic handled by the various groups of equipment.

SENDER MONITOR EQUIPMENT

In most of the offices already installed the sender monitor positions are combined with outgoing trunk test positions in which case the combined desk is known as the "trouble desk". It is now the practice to handle the sender monitor work at intercepting positions of the Panel system "A" board where the larger operating force insures prompt handling of stuck sender calls at all hours of the day or night. The new method is the one considered in these notes.

Equipment Located in Panel System "A" Board

The following circuits are located on the sender monitor positions of the Panel system "A" board.

Sender Monitoring Circuits. There is a talking jack, stuck sender lamp, and priming jack located at the sender monitor position for each sender. A "no-coin" lamp is provided in addition for each coin sender. A steady stuck sender lamp indicates that the sender has been made busy by inserting a make-busy plug in the make-busy jack, located at a "sender make-busy frame"; a flashing lamp indicates a stuck sender or a partial dial condition. A steady no-coin lamp indicates that no coin has been deposited on a call which requires that a coin be deposited. The stuck sender and coin lamps are associated with a separate night alarm circuit from the one associated with the regular panel and night alarm

circuit at the other Panel system "A" positions. These lamps and talking jacks are the ones which were mentioned in Chapter XIV.

Coin Control Monitoring Circuits - There is a talking jack, a lamp, and a priming jack located at the sender monitor position for each coin control circuit. The lamps are associated with the same buzzer and night alarm key as is provided for the sender monitoring circuits. The steady lamp indicates a trouble condition in the coin return position and a slow flash indicates a trouble condition in the coin collect position.

Permanent Signal Holding Trunks - The permanent signal holding trunks from the district multiple terminate at the sender monitor position of the Panel system "A" board, there being a jack, lamp and disconnect key per circuit. These lamps connect to the regular panel pilot and night alarm circuit in the Panel system "A" board. A lamp and key associated with the permanent signal trunk overflow circuit are mounted in the piling block and marked $\frac{PS}{OVF}$. The lamp lights whenever all of the permanent signal trunks from a group of frames are busy. Operation of the key extinguishes the lamp.

Plugging-Up Circuits - If the sender monitor operator is unable, on a permanent signal condition, to get the subscriber to replace the receiver on the hook, or if either a permanent signal or a stuck sender condition is due to trouble on the subscriber's line, the machine switching equipment connected thereto must be released for service; but the line must be held so that it will not originate another call and so that calls to this line will be intercepted. Such subscriber's lines are held by connecting them to plugging-up lines which are furnished for this purpose. The plugging-up lines originate in a jack box at the M.D.F. and terminate in a bridging jack and two cut-off jacks at the monitor position. A patching cord is used in connecting a plugging-up line with a particular subscriber's line; a plug on one end of the cord is inserted in place of the heat coils on the vertical side of the M.D.F. and the plug on the other end is inserted in a jack at the jack box. The plug at the M.D.F. makes separate contact with the line outside and the line inside the office so that one of the cut-off jacks is connected to the line outside and the other is connected to the line inside the office. These jacks are known as the trouble observation and test jack and the trouble intercepting jack, respectively. This arrangement also permits

testing the outside and inside line separately by the use of the test cord which connects to the local test desk.

Trunks Transferred from Repair Clerk's Desk - For night service certain trunks incoming to the repair clerk's desk can be transferred by operation of a key so as to connect to answering jacks located at the sender monitor positions. The lamps associated with these jacks connect to the panel pilot and regular night alarm circuit in the Panel system "A" board.

All Senders Busy Alarm - A group of lamps for all senders busy alarm circuits, which are located on the floor alarm board, are multiplied at the sender monitor position; they are not connected with a pilot lamp or night alarm circuit.

Tie Lines to Sender Make-Busy Frame - A tie line is provided between the sender monitor positions in the Panel system "A" board and the sender make-busy frame. This line is a two-way automatic circuit terminating at the Panel system "A" board in an answering jack and lamp for incoming service, and an outgoing trunk jack for outgoing service. The circuit terminates in a lamp and key on the make-busy frame, and a multiple of the line appears at the chief switchman's desk and at the outgoing trunk test desk, if specified.

Tie Lines to Repair Clerk's Desk - The tie lines between the repair clerk's test desk and Panel system "A" board are all terminated at the sender monitor position instead of at special service positions, as was formerly the case in those offices where the sender monitor positions are combined with the outgoing trunk test positions at the trouble desk.

Cord Circuits - The cord circuits used on the sender monitor positions of the Panel system "A" board are the same as regular intercepting cords, except that coin collect and return keys are provided when required. One emergency completing cord is provided for completing emergency calls which come in over a sender supervisory circuit; the use of this cord connects the subscriber's line to a special service operator, but the sender monitor can remain in on the connection to assist in passing the necessary information to the special service operator.

Test cords which connect to lines from the local test desk are also provided at the sender monitor position, and a call circuit is provided between the sender monitor and test desk so that information may be passed relative to

the use of the test cords. The keyshelves used at the regular intercepting positions are modified as required for use by a sender monitor operator.

Equipment Located in Switch Room

A sender make-busy frame is associated with the subscriber's sender test frame which is located in the switch room. On the make-busy frame is mounted the equipment for the following circuits.

A stuck sender lamp circuit and a make-busy jack for each subscriber's sender. No pilot or alarm is provided for this circuit. When a sender is to be made busy a make-busy plug is inserted in the make-busy jack, thus lighting the stuck sender lamp at the sender monitor position as was previously described.

All-senders busy alarm circuits for subscribers' senders with which are associated aisle pilot lamps and a sender alarm bell which rings steadily; additional pilot lamps are located at the floor alarm and main alarm boards.

Tie line and talking circuits to other desks.

The equipment for miscellaneous circuits is located elsewhere in the switch room as follows:

Make-busy jacks for "A" operators' local tandem and cordless "B" senders are located on the sender test frames which are used for testing these senders.

Stuck sender lamps and the all-senders busy alarm circuits for local tandem senders are located on the local sender test frame. The stuck sender lamps light steadily regardless of the stage at which the trouble condition occurs. An audible signal is operated when any one of the sender lamps is lighted. When a make-busy plug is inserted in the make-busy jack the alarm is retired. If any sender becomes stuck the alarm again operates.

Miscellaneous alarm pilots are located in the floor alarm board on the same floor with the chief switchman's desk, this alarm board being known as the main alarm board.

LOCAL TEST DESK

A local test desk is provided for use in testing subscribers' lines, outside cable pairs, and switchboard multiple. Where there is more than one office in a building the one test desk serves all of the units, both manual and machine switching. In some cases this testing is centralized in one test desk for a part or all of the offices in an area. The desk is made up of as many one position units as are required to take care of this work. Testing and recording keys and testing cords are mounted in the keyshelf, while key ended trunks and jack ended lines appear in the face of the position. A volt-milliammeter is also mounted in the face of each position.

The following key ended trunks are provided, a lever type key and lamp being associated with each.

One-way trunks from final frames, which provide means for obtaining a connection to the local test desk through the exchange apparatus.

Two-way talking lines between local stations and the test desk.

The local stations are regular subscribers' wall sets used by the maintenance force in talking to the test man at the local and outgoing trunk test desks, the lines being multiplied to both.

A two-way trunk for use in receiving or originating a call at the local test desk.

Two-way 3 wire automatic trunks for use in communicating with the assistant chief operator, chief switchman, Sender Make Busy Frame, and Trouble Desk.

Two wire automatic trunk line to Toll Board.

Three wire automatic trunk line to Panel system "A" switchboard.

The following key ended trunks terminate on push button type keys: Trunks for talking on lines that are bridged to other lines, on which common battery supervision is required.

Trunks for talking on lines that are bridged to other lines, on which common battery supervision is not required.

Trunks to other test desks (private line system).

Trunk lines to "B" supervisor's sets in manual central offices.

The following test lines are provided at the local test desk with each of which is associated a jack, a lamp with a red cap, a lamp with a white cap, and a key.

Test lines to incoming test selectors located on a regular incoming frame for use in testing subscribers' lines. To make a test the plug of a test cord is inserted in the jack, the number of the line to be tested is written up on the numerical recording keys and the sender associated with this cord causes the line to be selected. Voltmeter tests are then made by the operation of the various test keys. These trunks are multiplied before each position; the red lamp is a busy lamp which lights at all positions except the one at which a plug is inserted, and the white lamp is a supervisory lamp which lights when the plug is withdrawn from the jack after connection has been established. The disconnect key is operated when the test man is ready to release the connection.

Test lines to sender monitor positions for use in connecting the test cords at the test desk to the plugging up lines located at the sender monitor positions.

Test lines from district or office multiple which are selected when a special code is dialed by an outside trouble man on a line which he wishes to have tested. The subscriber's line is tested thru this connection.

Two test lines to the MDF used in connecting to the subscribers' lines at the vertical side of the MDF. These lines terminate in a jack box at the MDF and are connected to subscriber's lines by a patching cord; the plug at one end is inserted in a jack in the jack box and the plug at the other end of the patching cord is inserted in place of the heat coils making separate connections with the line outside the office and the line inside the office.

The test line terminates at the test desk in a bridging jack for listening and two cut-off jacks; one of the cut-off jacks is known as a trouble observation jack and connects thru the test line and patching cord to the line outside the office, while the other cut-off jack is known as a trouble intercepting jack and connects to the line terminals inside the office.

Two test lines to MDF and IDF for detecting intermittent trouble. Each line originates in a plug at the MDF which is inserted in place of the heat coils, in a plug at the IDF which connects to the line sleeve lead, and in a clip on the line finder frame for connecting to the armature of the line relay. The line terminates on the test desk in a bridging jack and two cut-off jacks with which are associated three lamps and two keys. A lighted red lamp indicates that the subscriber's line is busy, a lighted green lamp indicates a ground or cross on the outside, and a lighted white lamp indicates a ground or cross inside the office. One key is used to monitor on a line while the other key is used to distinguish between an individual line and a line of a P.B.X. group.

The following equipment is provided in the keyshelf of local test desk positions:

Call circuit keys for connecting the test man with operators at the Panel system "A" board.

Ringling keys, for ringling on the primary test cord and for ringling on the secondary test cord.

A primary test cord, which is used in making ground, foreign battery, resistance, talking, ringling, transmission, coin collect, line insulation breakdown, and loop tests requiring the use of a Wheatstone Bridge.

A secondary test cord which is arranged for making only those tests which do not involve the use of the volt-milliammeter and Wheatstone Bridge and which is arranged for applying machine

ringing, the howler, dial test and the sounder. The primary and secondary test desk cord circuits can be interchanged, with respect to the cords, by operation of a test cord interchange key "X".

A sounder cord which is used to show intermittent ground, short-circuit, or open conditions on a line. When trying to locate an intermittent short circuit or ground the cord is connected, to the line under test in such a manner as to cause the operation of a sounder (or buzzer) when a short circuit or ground comes on the line; and when trying to locate an intermittent open, the cord is connected to the line in such a manner as to cause the operation of the sounder (or buzzer) when the line goes open.

A Wheatstone Bridge cord and circuit, which is used in making Murrery and Varley loop tests is controlled by keys which set up the circuit conditions for either of these tests.

A howler key, whose operation applies a graduated howler tone to the line into which the secondary test cord is plugged.

A dial test key, whose operation connects the secondary test cord with the dial test apparatus. The "dial tester" is wall mounted and is used either from the local test desk or directly from a subscriber's line over a special test line from the district or office multiple. A dial tone is transmitted to the subscriber's station as soon as the test apparatus is ready to receive pulses and after the pulses have been received a tone is transmitted to indicate the results of the test. The tone thus transmitted indicates either a slow, an "O.K.", or a fast dial.

An insulation breakdown test key, whose operation applies a 200 volt breakdown potential. The maximum voltage is applied and removed gradually.

DESK SENDER FRAME

A desk sender frame is provided which has space for mounting the ap-

paratus associated with seven test desk senders and seven howler circuits which includes sequence switches, power driven interrupters, 200 type selectors, retard coils, relays, resistances, condensers and a fuse panel. The sender receives the registration from the numerical recording keys at the test desk position and controls incoming and final selections.

OUTGOING TRUNK TEST DESK OR TROUBLE DESK

An outgoing-trunk test desk is provided primarily for testing outgoing inter-office trunks and for making these trunks busy, when out of service. The desk is made up of as many two position sections as are required to take care of this work, the outgoing trunks being multiplied to test and make-busy jacks in the face of the desk. The test equipment is essentially the same as that at the local test desk, which has already been described. The tip and ring conductors of each trunk are connected to the test jack and the sleeve conductor is connected to the make-busy jack. Where a trunk distributing frame is used these jacks are wired to this frame but where the outgoing trunks are wired directly from the selector multiple to the horizontal side of the MDF the jacks are also wired to the MDF. Designation strips indicate the district or office bank to which these trunks are connected and on what frames they are multiplied.

Key ended talking lines provide for communication with the local test, repair clerk's, chief operator's, and switchmen's desks, with local station telephones, and with the various equipment frames; two of these lines may be associated with each key. Two-way trunk lines are furnished for originating calls from and completing calls to the O.G.T. desk thru the regular Panel system equipment. Test desk lines are also provided directly to the test desks in distant offices.

REPAIR CLERK'S DESK

A repair clerk's desk is provided adjacent to the local test desk for handling trouble reports from subscribers. A card file is located at this desk in which there is a card for each subscriber's line. On the card is recorded the cable pair and terminal box data, the date of installation, all troubles reported concerning the line, and their disposition. The lines terminating at a repair clerk's desk are key ended, leaving the desk space free for writing up the trouble tickets and making the records on the cards. The circuits provided include:

Lines from district or office multiple which are selected when a subscriber dials the repair clerk's code 611.

Lines from final and line finder frames which provide for communication both to and from the repair clerk's desk through the regular exchange apparatus.

Two-way tie lines from the sender monitor positions, outgoing trunk test desk, special service operators' positions of the Panel system "A" board, and the commercial office.

An operator's telephone circuit to which any line is connected by operation of the individual trunk key.

TRAFFIC DESKS

The traffic desks in a panel machine switching office are an assistant chief operator's desk and a chief operator's desk. In some cases only the assistant chief operator's desk is furnished.

The assistant chief operator's desk is a flat top double sided desk on which is mounted a turret arranged for key ended and jack ended trunks on both front and rear. Two-way key ended lines are multiplied to both sides of the turret for use by the assistant chief operator on one side and the clerk on the other side in establishing and receiving calls. These lines include trunks from the final frame, local test desk, outgoing trunk test desk, sender monitor positions, chief operator's desk. Monitoring lines to Panel system "A" and cordless "B" operators and supervisors are jack ended either on one or both side of the turret. Each side of the desk is provided with a telephone circuit, a monitoring cord, a flashing key, a transmitter cut-out key, and a key for connecting the monitoring cord to the telephone circuit.

The chief operator's desk is a single or double sided flat top desk on which is mounted a small key box. Two lines from the final multiple, one line to the assistant chief operator, and one monitoring line from the assistant chief operator are provided, together with a telephone set and circuit.

SERVICE OBSERVING DESK

A service observing desk is provided in a machine switching office for

use by the Traffic Department in making observations on calls in determining the quality of service being rendered by the office. The service observer can follow the progress of a call from the time it is originated until the connection has been released. The desk is an ordinary flat top desk on which is mounted a turret containing the lines and supervisory signals, operator's telephone circuit and control keys. It has a capacity of sixty service observing trunks which terminate in a jack box at the IDF; 40 are used for observing on subscribers' lines and the other 20 may be used for observing on miscellaneous trunks. Any subscriber's line is connected to one of these trunks by the use of a plug-ended patching cord, the plug at one end being inserted in a jack at the jack box and the plug at the other end being attached to the line terminals on the vertical side of the IDF. When a call is originated on one of the subscriber's lines, which are connected to these trunks, it is automatically connected and locked in on the operator's telephone set. The other lines are locked out until the calling subscriber replaces the receiver on the hook. A pen register is provided for recording the dial pulses received, so that the number actually dialed by the subscriber can be determined and errors in the manipulation of the dial can be checked. When it is evident that an error has been made by the machine switching equipment the connection can be held, by putting a bridge across the line. Provision is also made for talking with a subscriber who has encountered difficulty in making a call.

TRAFFIC REGISTER RACK

A unit type traffic register rack is provided on which are mounted the traffic registers used in full mechanical equipments to record the traffic handled by groups of line finder, sender, office selector, incoming selector, and final selector circuits; these registers are known as "group" registers. Other registers known as "all trunks busy" or "overflow" registers are provided for indicating the frequency with which a selector finds all trunks busy. On the rack is mounted such relay, key, fuse and terminal strip equipment as is required for the register circuits.

SWITCHMEN'S DESKS

A chief switchman's desk is provided for each office, and an additional switchman's desk is provided on each floor having machine switching apparatus.

The chief switchman's desk is a flat top, single position desk with drawers on each side; it is equipped with a telephone circuit and a turret in which are terminated key ended talking lines for use in supervising the maintenance men and for establishing connections through the exchange apparatus. The switchmen's desks are small, single sided, single position desks used in making records; they are equipped with a telephone circuit and such lines as are required for communication with the chief switchman's desk, other switchmen's desks, the outgoing trunk test desk, and sender make-busy frame. The chief switchman's desk is usually located near the outgoing trunk test board.

Floor Alarm Boards

The present standard arrangement of alarm boards locates one or more bays of floor alarm board on each floor having machine switching equipment except the floor that is occupied by the power apparatus. On the floor alarm board are located the alarm lamps which light whenever there is some portion of the machine switching equipment which requires attention. These lamps are associated with fuse alarm, time alarms, motor stop alarms, motor transfer alarms, pulse machine alarms, ringing machine and "pick-up" alarms when the ringing machines are not located on the same floor with the power equipment, cordless "B" position emergency alarms, automatic routine test circuit alarms, and an auxiliary night alarm.

When one of these alarm circuits is operated a lamp at the floor alarm board lights and an alarm bell rings attracting the attention of a switchman. The alarm bells for ringing machine and pulse machine troubles are D.C. single stroke gongs, while the alarm bells for practically all other kinds of trouble are A.C. ringers. The lamp indicates what kind of trouble is causing the alarm (whether a fuse has been blown, a motor stopped, a selector stuck, etc.) and indicates the location of the trouble.

On each of the floor alarm boards there are floor pilots so that the operation of an alarm on any floor lights the corresponding floor pilot lamp on all floors. One of the floor alarm boards is known as the main alarm board and it has additional supervisory lamps for all of the floors which indicate the nature of the trouble which has caused the lighting of one of these floor supervisory lamps. The operation of an alarm on any floor also causes operation of

the audible alarm at the main alarm board. With this arrangement the chief switchman knows on what floor a trouble is located, what kind of a trouble it is, and knows the promptness with which the switchman on that floor responds to the alarm.

An audible alarm switching circuit is provided for connecting the audible alarm on one floor in multiple with that of the floor above, so that, when one switchman is taking care of two or more floors, the operation of an alarm on any of these floors will signal the switchman no matter on which floor he may be. The switching keys are located at the main alarm board and the circuit is so arranged that the operation of either an AC or a DC alarm on one of the floors lights the corresponding pilot lamp at each of the floors so grouped. The floor pilots previously mentioned indicate on which of the floors a trouble exists.

Aisle pilot lamps and audible alarms are provided to further assist the switchman in locating the equipment which is in trouble. A red aisle pilot indicates a fuse alarm, a white aisle pilot indicates a selector, link or trip circuit time alarm, a green aisle pilot indicates a Coin Control or Start circuit time alarm, and a yellow aisle pilot indicates a test frame time alarm. The audible alarms associated with the aisle pilots are A.C. ringers, each located near the equipment with which it is associated; there is a different ringer for each of seven alarm circuit groups which are: (1) Link Circuit Fuse and Time Alarms and Start Circuit Time Alarms, (2) Line, Trip and Start Circuit Fuses, (3) District and Coin Control Frame Alarms, (4) Sender Frame Alarms, (5) Office Frame Alarms, (6) Incoming Frame Alarms, and (7) Final Frame Alarms. Miscellaneous equipments such as test frames, RCI make busy frame, etc., are connected to the aisle pilot audible alarm of the equipment nearest to which they are located. In general the fuse alarm causes continuous operation of the audible ringer and a time alarm causes operation of the ringer under control of the ringing machine interrupters.

Individual frame or individual circuit lamps indicate the particular frame of a group or the particular circuit on a frame which requires attention. Start and Trip circuits have individual alarm lamps, the various frames have individual time alarm lamps, and there is a frame pilot lamp on each frame fuse panel, all of which assist the maintenance force in locating the cause of an alarm.

The fuse alarm lamps on the floor alarm boards are associated with line finder, link, district, sender, office, incoming, final and all other individual frame fuse panels, and with pulse machine power distributing and miscellaneous fuse panels. An operated fuse on one of these panels gives a visible indication that it has operated; as a result of its operation a frame fuse panel lamp lights, the aisle pilot lamp lights, the aisle pilot alarm bell rings, the group pilot lamp lights at the floor alarm board, the floor alarm bell rings, the floor pilots light on all of the floors, the main alarm pilot lamp lights and the main alarm bell rings.

The time alarm lamps are associated with trip, start, link, line finder-district, and automatic testing circuits. When any one of these circuits fails to complete various portions of its normal operation within certain allowable times, as measured by power driven interrupters, the time alarm associated therewith is operated.

When a frame motor stops and the alarm is operated, a frame make-busy relay also operates making all of the circuits, driven by this motor, test busy. When the outside power supply is cut off from a particular frame motor or pulse machine motor but has not failed in the whole office the motors so effected are transferred to the storage batteries and the corresponding individual motor transfer alarm lamps at the floor alarm board are lighted. In case of a total outside power failure a power service master switch operates lighting a lamp at the main alarm board, in addition to the alarm at the power alarm cabinet and although each motor is transferred to the storage batteries as before mentioned the individual motor transfer alarm lamps at the alarm boards do not light.

The pulse machine fuse and battery alarm circuit is arranged so that the operation of a pulse lead fuse, a battery cross, or a timing lead failure lights the corresponding lamp in the floor alarm board, lights a pilot lamp in the main alarm board, and operates auxiliary signals at the floor alarm and main alarm boards. These alarms are released after the trouble condition has been removed by the operation of a release key.

When the ringing machines are not on the same floor as the power alarm cabinet the failure of the ringing generator voltage, failure of the machine ringing current, failure of coin control current, failure of high or low tone, or a

trouble ground on any of the "pick-up" leads lights corresponding alarm lamps at the floor alarm board; pilot lamps are lighted at the main alarm board and at the power alarm cabinet and auxiliary signals are operated at the floor alarm board, the main alarm board, and at the power alarm cabinet.

Each machine switching "B" operator is equipped with an emergency key to be operated when the position is out of order. Operation of the key lights lamps at the main and floor alarm boards calling maintenance men to the position and to the cordless "B" frame equipment associated with this position. When the key is restored to normal the lamps are extinguished and the alarm bells are silenced.

When an automatic test circuit is blocked on account of locating a trouble or on account of failure within itself "Test Frame" alarm lamps are lighted at the floor alarm and main alarm boards, the associated aisle pilot lamp is lighted and the various audible alarms are operated.

- A- TEST LINES TO TEST INC SELS, FROM TERMS ON DIST OR OFFICE FRAMES TO TROUBLE DESK, TOLL SWBD, M.S.A. BD, OR TO SWBDS. OF MANUAL CENTRAL OFFICES.
- B- KEYS FOR TRUNK LINES TO BRIDGE ON OTHER LINES REQUIRING COMMON BATTERY SUPERVISION OR TO OTHER TEST DESKS.
- C- KEYS FOR TRUNK LINES TO SUPERVISORS' SETS IN MANUAL CENTRAL OFFICES.
- D- JACKS FOR SECONDARY RINGING CKT. WHEN REQ. AND FOR MISC. PURPOSES.
- E- TEST LINES TO I.D.F. & M.D.F. FOR DETECTING INTERMITTENT TROUBLE TO M.D.F. AND TO TEST PANELS.
- F- LOUD SPEAKER EQUIPMENT.
- G- KEY FOR LINE INSULATION BREAKDOWN TEST.
- H- KEY FOR TELEPHONE TRANSFER CIRCUIT WHEN REQUIRED.
- I- PERMANENT SIGNAL HOLDING TONE KEY.
- J- BUZZER KEY FOR TEST LINES, ONE POSITION ONLY.

- K- BUZZER KEY FOR TRUNK LINES, ONE POSITION ONLY.
- L- KEY FOR RHEOSTAT.
- M- SENDER LAMP, GREEN CAP.
- N- SENDER OVERFLOW LAMP, WHITE CAP.
- P- EQUIPMENT FOR 2 TEST LINES TO JACK PANELS.
- Q- EQUIPMENT FOR 4 TEST LINES TO M.D.F.
- R- JKS. FOR 2 TEST LINES TO I.D.F. AND M.D.F. FOR DETECTING INTERMITTENT TROUBLE.
- S- TEL. CKT. KEYS FOR THE 2 TEST LINES MENTIONED UNDER "R".
- T- PB.X. KEYS FOR THE 2 TEST LINES MENTIONED UNDER "R".
- U- SHORT CIRCUIT JACK CIRCUIT.
- V- LAMPS FOR TEST CKT. NO.1 MENTIONED UNDER "R".
- W- LAMPS FOR TEST CKT. NO.2 MENTIONED UNDER "R".

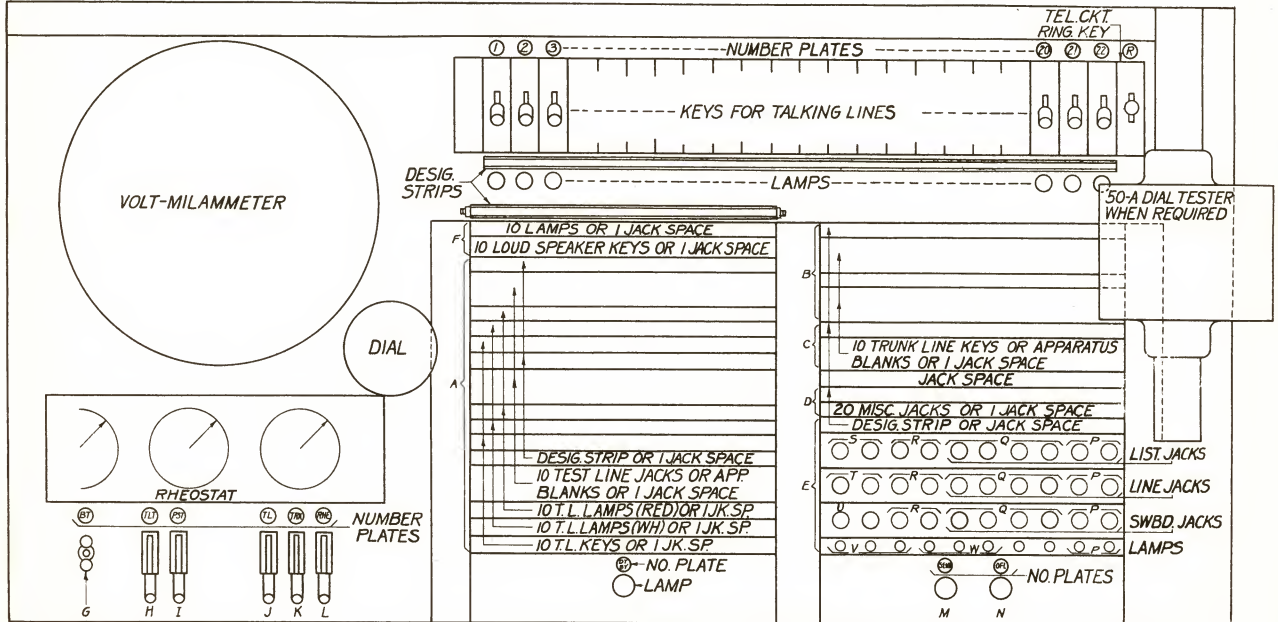

FRONT EQUIPMENT

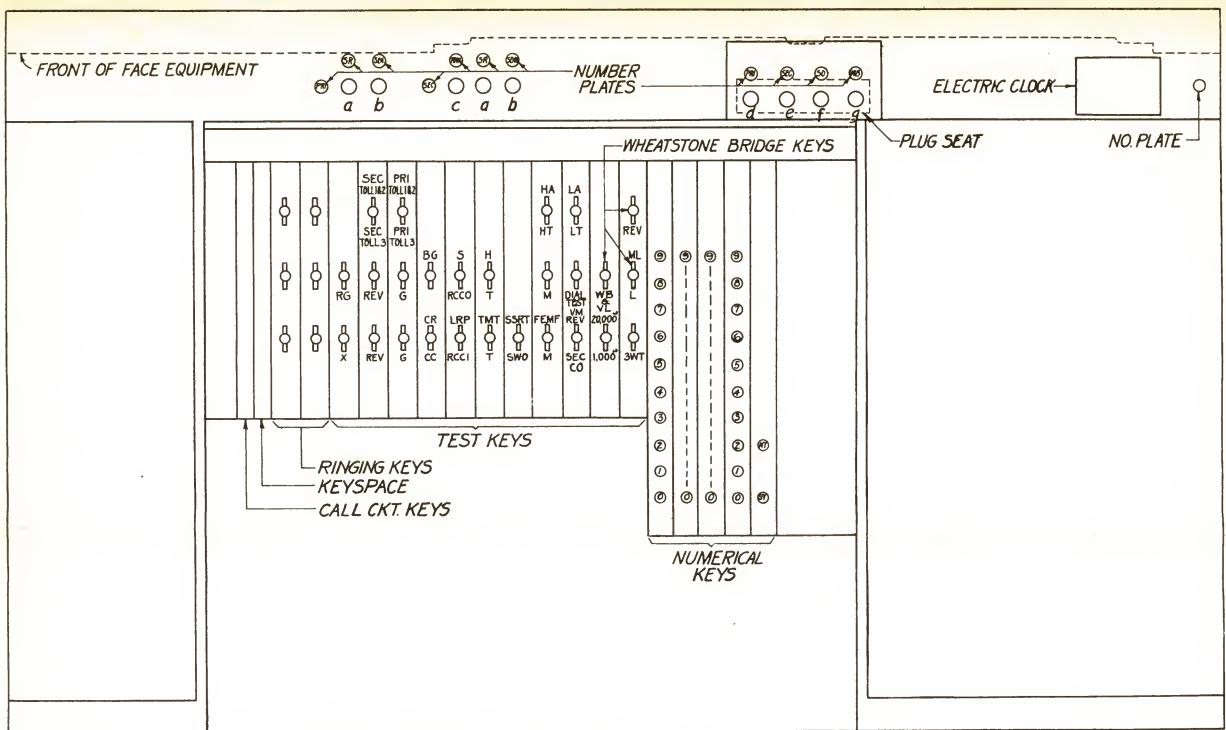

KEYSHELF EQUIPMENT

- a- SUPERVISORY LAMP WHITE CAP.
- b- SENDER LAMP GREEN CAP.
- c- RINGING LAMP RED CAP.
- d- PRIMARY TEST CORD.

- e- SECONDARY TEST CORD.
- f- SOUNDER CORD.
- g- WHEATSTONE BRIDGE CORD.

KEYSHELF AND FRONT EQUIPMENT-LOCAL TEST DESK
FIG. 1

CHAPTER XXIV

ROUTINE TESTING

It is essential that the equipment in a machine switching office be kept in proper working condition. The amount of apparatus used and its complexity multiplies the opportunities for trouble in a panel office as compared with a manual office. To find defective apparatus before it has caused failure is the main purpose for which Routine testing equipment is provided. This equipment is of two general types, Portable and Automatic.

Automatic Routine test circuits are arranged to select and test, one after another, all of the circuits in any group. The particular circuit under test is made busy during the time it is being tested, and is put through all or a part of the operations which it would normally make on a regular call. Each step of its progress is checked and if the circuit is found to be in good condition, it is released and the test circuit advances to the next circuit in the group. In case the circuit fails to properly complete any particular step, the test circuit stops the test, gives an alarm, and indicates the nature of the trouble encountered. Automatic routine test frames and circuits are provided for "routining" the groups of all major circuits, namely, Sender Circuits, District, Office, Incoming and Final Selector Circuits, and for testing the Pulse Machines.

Portable test circuits are provided for use in testing groups of circuits which are not large enough or complex enough to warrant providing automatic equipment, and for use in making auxiliary tests on the equipment for which automatic test equipment is provided. This type of equipment, which is also known as "Manual Routine test" equipment is made up in the form of test boxes and test wagons. The wagon type test circuits include an "Office, Incoming, and Final Selector Test Circuit", a "Subscriber's link test circuit", a "Two-Wire office selector test circuit" and a "Subscriber's" line test circuit". The box type test circuits include a District Selector test circuit, a "B" position Incoming Selector test circuit, a Coin Control test circuit, a 200 type Selector test circuit, a Message Register test circuit, a "B" position key unit test circuit, a tripping relay adjusting test circuit, a Patching Cord test circuit, and a

35-C test circuit which is used in testing and adjusting relays and other apparatus by the current flow method.

A cord test circuit is provided for testing the cords at the panel system "A" board, the equipment being mounted on a frame in the switchroom but it is non-automatic in operation. The circuit is multiplied to test jacks at the "A" board and each cord can be inserted in these jacks.

Routine test equipment is designed to function properly when the voltage is maintained between 48.5 to 50 volts, so as to approach as closely as possible to making current flow tests which are no more severe than test values and no easier than worst circuit conditions. Tests made when the voltage is not maintained within these limits do not give a fair indication of trouble conditions.

Testing Subscriber's Senders

The sender test circuit is used either for routining all the sender in an office or for locating a particular trouble that has been reported on a particular sender.

It is necessary that sender routine testing equipment be driven at practically a constant speed and a specially designed 48-volt DC motor is used on sender routine test frames. The motor is driven from the exchange battery and contains a speed regulating device by which a practically constant speed is maintained throughout a voltage variation of from 45 to 50 volts.

The apparatus for a sender test circuit is mounted on a subscriber's sender test frame as shown in Figure 1. Figure 2 shows schematically the means for connecting the test circuit to the various sender circuits. The test frames are essentially the same for two, two-three, and three digit sender test circuits. Six leads from each sender, T, R, SC, FT, FR and TL are connected to sets of terminals on 200 type selectors mounted on the test frame; 18 senders (from 3 frames) are connected to each one of the selectors, which are known as selecting switches, there being as many selecting switches as are required to take care of all of the senders in the office. The leads from the six brushes of each selecting switch are in turn connected to sets of terminals on a master switch (200 type) whose six brushes connect to the T, R, SC, FT, FR and TL leads in the test circuit. The leads from each sender are the same leads which are

multiplied on the sender multiple banks on the panel link frames, except that the TR lead is replaced by the TL lead so as to permit the testing of a sender which has been made busy at the sender make-busy panel. The operation of a Stepping key associated with the master and selecting switches connects the test circuit to any particular sender. When routing all senders these switches advance automatically from one sender to the next after each test is completed; when all senders have been tested the selectors return to normal and a lamp lights to indicate that the tests have been completed, unless a key has been operated which causes the test circuit to repeat the tests on all senders in the group.

Normally only one type of test call (mechanical class, Direct RCI class, Operator Class, etc.) is made on each sender when "routing". Having operated the keys which control the tests which are to be made, the operation of a Start key begins the testing on the first or any particular sender. When the test circuit connects to a sender it makes a preliminary test to determine whether or not the sender is busy and is arranged to do one of three things if it finds the sender busy. First, it may immediately pass-by the busy sender; second it may wait a certain period of time, and then pass by if the sender has not become idle within this time; and third it may wait and if the sender does not become idle within a certain length of time operate a time alarm. As soon as a sender is selected for test and is found idle, the test circuit makes it busy to regular service and then proceeds with the cycle of tests to be made. The test circuit contains apparatus which produces interruptions corresponding to dial pulses and transmits them to the sender so as to set the office code and numerical registers; it contains apparatus for duplicating the operation of the district, office, incoming and final selectors on a mechanical class test, or of the district, office, RCI trunk, and RCI control circuits on an RCI class test; and it contains means for checking the correctness of each step, means for giving an alarm when trouble is encountered, and means for indicating the nature and location of the trouble. The number of counting relays operated in the sender for each selection is checked by a set of counting relays in the test circuit, both sets being operated by the same pulses supplied by the test circuit. Provision is made for testing under maximum or minimum line or trunk loop conditions. After a trouble has been found and recorded, operation of one key restores the

time alarm circuit to normal and operation of another key advances the test. By operation of a repeat key the test will be repeated on the same sender until the key is released. The operation of the repeat key together with the operation of another key causes four single tests to be made successively on each sender.

Testing "A" Operators and Local Senders

The test circuit and the test frame, on which the apparatus is mounted, for testing "A" operators and local tandem senders is very similar to that used in testing Subscriber's Senders. Since the number of "A" and Local Senders is not large, only one test circuit is furnished. The senders are selected for test by means of master and selecting switches. Two control keys are provided, one of which is operated when an "A" (or suburban) sender is to be tested, the other being operated when a local tandem sender is to be tested. Since dial operation does not have to be duplicated, the means for simulating dial pulses is replaced by apparatus for duplicating the setting of the "A" operators' recording keys, and by apparatus for duplicating the sending of RCI pulses into the local tandem sender. On this frame are located the "A" and local sender make busy jacks as described under "Sender Monitor Positions" in a preceding chapter. Lamp and key equipment is provided for supervision and control, as in the subscriber's sender test circuit.

Testing "B" Senders

The apparatus included in a "B" sender test circuit is mounted on a "B" sender Test Frame. A sender selector located on a "B" sender and link frame is used in connecting to any one of the senders in the group. This sender selector is known as a test selector and cannot be used for regular service. The "B" sender test circuit is much simpler than the subscriber's sender test circuit, as the cordless sender is much simpler than the subscriber's sender. It is arranged to set up numbers in place of those set up at a cordless "B" position on a regular call and transmit them to the sender being tested. A set of counting relays checks the operation of the sender counting relays, both being operated by the same pulses from the test circuit. Lamp and key equipment provides for supervision and control of the test circuit.

Finding a Stuck Sender and the Associated District

When a sender becomes stuck it should be located as soon as possible

so that the defective apparatus can be made busy and the other apparatus connected thereto be released for regular service. To this end a "link finder frame" is provided on which are mounted a number of "link finder selectors" (200 type). One lead from each link circuit terminates on a bank of one of these 200 type selectors. Five of the arcs on a selector are used for this purpose so that 100 links connect to each link finder bank. When a sender is stuck and the ticket which is made out by the sender monitor has been passed to the maintenance force, a switchman operates a start key associated with the group of senders, in which the particular sender is included. The 200 type selectors associated with this group begin to rotate, testing the terminals of each of the 5 arcs; if a permanent ground is found on any terminal the selector stops and lamps are lighted which indicate the selector and terminal number at which this ground was found. A translation chart tells the switchman where the link circuit is located. The start key is again operated and the selectors return to normal, testing the remaining terminals in so doing. After locating the link connected to the stuck sender, the switchman makes busy whatever portion of the equipment (sender, link, district, office, incoming or final) is defective and releases the remaining equipment for regular service.

Testing Line Finder - District Selector Circuits

One District Selector Test Frame and circuit is furnished for every 1600 line finder - district selector circuits in an office and, when two test circuits are required, they both have access to all line finder - district circuits in the office. The means for connecting the test circuit to the various line finder - district circuits to be tested, and to the Start, Trip and Test line circuits which are associated with the various line finder and district frames, is shown schematically in figure 3.

The line finder-district circuits are divided into groups of 400 for test purposes and a master switch (200 type) directs the test circuit to any one of these groups. The six leads, T, R, SC, FT, FR and TR which connect to the district multiple on the panel link frame are also multiplied to the terminals of 200 type connector switches. There is one connector for every 20 line finder district circuits and there are therefore 20 connectors for each of these groups of 400 circuits. Associated with each group of 20 connectors is a set of 4 group

connectors (200 type) of which one arc is used for connecting the test circuit to the originating test line terminals on the various line finder frames, one arc is used for connecting to the regular Start circuits, one arc is used for connecting to the Trip magnets associated with the banks in which the originating test line terminals are located (the first set of terminals in the first bank on each line finder frame is used as the originating test line), and one arc is used (together with relays) for connecting the T, R, SC, FT, FR and TR leads to the six brushes of each of the 20 connectors associated with the 400 line finder-district circuits that are in one group as controlled by the master switch; of the remaining arcs in each set of 4 group connectors, certain ones are used for synchronizing the advance of the 4 group connectors.

The tests to be made are controlled by locking keys so arranged that any one, any combination, or all of the different tests may be made on each district circuit in succession. The operation of a start key (ST) is necessary to start the test on the first circuit but thereafter, the test circuit is advanced automatically until all circuits have been tested or until a trouble is encountered, in which case the test circuit is blocked, and an alarm is operated; the position in which the test circuit sequence switch is blocked and the lighting of one or more of the supervisory lamps indicates the nature of the trouble. Before testing any circuit, a preliminary test is made to see whether this circuit is idle or busy; if busy the test circuit may wait for it to become idle in which case, an alarm is operated after waiting a certain length of time, or if a certain key has been operated, the test circuit will pass by busy districts; if idle, the link circuit attached thereto is dismissed and the district is made busy so that it will not be reselected by any link circuit during the routine test. This district is then tested as soon as the regular Start circuit is free. That is, as soon as the Start circuit (on the line finder frame on which is located the line finder to be tested) has completed its operation in starting a call which has already been originated and there are no other lines on this frame waiting to be started, the test circuit blocks the Start circuit, operates the Trip magnets associated with the bank in which the originating test line terminals are located, connects battery thru 250 ohms resistance to the "H" terminal of the test line, and then operates the (LF) relay in the line finder-district circuit

which is being tested. This line finder is driven upward and as soon as it has passed the tripping zone, the Start circuit is released for regular service. The line finder should stop on the originating test line terminals. The test circuit has its own sender which so controls the district selector as to cause the selection of a set of terminals to which a district selector test line is connected. There is one of these test lines associated with each test circuit, the first connecting to the 91st, and the second to the 92nd, set of terminals on the 5th bank of the district frames unless the test call is completed through an office selector, in which case the test lines are similarly located on a group of office frames. Both test circuits can be used at the same time but cannot be testing in the same group of 400 districts.

A portable district selector test circuit of the box type is also provided for use in making such tests as are necessary in locating trouble, or for testing a circuit which has been repaired or adjusted before turning it back into service. Connection is made with a particular circuit at the test jack panel mounted on the individual district frames. A regular sender is used when testing with this set.

Testing Office Selectors

An automatic routine test circuit is provided for testing 3 wire office selector circuits, but none has been developed as yet for testing 2 wire office selector circuits. Selectors on district frames are used by the test circuit (one for each group of trunks, from the district multiple, which connect to office selectors) in selecting and connecting to the 3 wire office selector circuits. Figure 4 shows schematically the means for connecting the test circuit to the various office selector circuits. Regular selectors are used for this purpose on subscriber's district frames, but where it is necessary to use "A" operator's district selectors for this purpose they cannot also be used for regular service. Usually the first selector on a frame is provided with additional leads which are wired to the office test circuit when the selector is to be used as a test selector. The leads from the test selectors connect to the test circuit under control of connector sequence switches and 200 type directing switches. An office selector test frame is arranged for one test circuit, 6 connector sequence switches and 5 directing switches. Each connector sequence

switch provides for the leads from 3 test selectors, and each directing switch provides the control leads for 20 different brush and group selections in reaching the various groups of trunks which connect to the office selector circuits to be tested. Thus one frame provides for a maximum of 18 test selectors and 100 different district brush and group selections by these 18 test selectors. The office selector circuit under test is so controlled by the test circuit as to cause the selection of an office selector automatic test line. When the tests have been completed the test circuit is automatically advanced to the next office selector circuit. The supervisory features are similar to those on the routine test circuits previously mentioned.

Two-wire office selector circuits are tested by a wagon type two-wire office selector test circuit which connects to the selector circuits at the test jacks on the office frames, the trunks being made busy, before test, in the originating office. The portable wagon type "Office, Incoming, and Final Selector Test Circuit" is also used in testing three-wire office selectors, the control keys being operated so as set up the proper conditions for this purpose.

Testing Incoming Selector Circuits

The means for connecting the incoming selector automatic test circuit to the incoming selector circuits are similar to those provided for connecting the office selector test circuit to three-wire office selector circuits. Incoming Selector circuits are therefore tested by the test circuit in the office in which these trunks originate. An incoming selector test frame is arranged for one test circuit, 8 connector sequence switches, 8 pair of directing switches, and 12 final multiple test lines. This takes care of a maximum of 24 test selectors and provides for 160 different brush and group selections by these selectors. The test selectors are located on district or office frames, or both, as required to reach all groups of trunks to incoming selectors. Having been connected to a particular incoming selector circuit the test circuit causes such incoming and final selections to be made as are necessary in reaching a final multiple test line. The final multiple test line, thus selected, controls the tests for checking the ringing and supervisory functions of the incoming circuit. When the cycle of tests has been completed the test circuit is advanced to the next trunk. The position in which the test sequence switch is blocked, on a case

of trouble, together with the lighting of supervisory lamps indicates the nature of the trouble encountered. The final multiple test line transmits various tones back to the test circuit according to the results of the tests made by this line. Provision is made for supervision as in the other routine test circuits previously described.

The final multiple test line equipment may be mounted on the incoming selector test frame or may be mounted on a separate "final multiple test line frame".

"B" position incoming selectors are not tested by the circuit just described, since there are no district or office selectors through which they may be chosen. The circuits to be tested are made busy in the originating office. A box type "B" position Incoming Selector test circuit is provided which is connected to the circuits to be tested at the individual test jacks located on the incoming frames.

The combination "office, incoming and final selector test set" may be used for making tests on individual incoming selectors; it is connected to the test jack of the circuit to be tested on the incoming frame.

Testing Final Selector Circuits

The means provided for connecting the final selector automatic test circuit to the Final selector circuits are similar to those used by office and incoming selector automatic test circuits. A final selector test frame (see figure 5) is arranged for one test circuit, six connector sequence switches, and five 200 type directing switches, thus providing for the use of a maximum of 18 test selectors and for a maximum of 100 different brush and group selections by these test selectors. Regular incoming selectors of such number and location as is necessary in reaching all final selectors are used as test selectors. The final selector circuit under test is so controlled by the test circuit as to select a "final test line" which connects back into the test circuit; two or three of these test lines are provided so that both Direct and PBX line tests may be made. The supervisory features are similar to those provided in the other automatic routine test circuits.

The portable "office, incoming and final selector test set" may be used in making tests on a particular final selector circuit by operating the proper keys. Connection is made to the circuits to be tested through the individual test

jacks on the final frames.

Testing Subscriber's Link Circuits

A Panel link testing circuit is used in testing subscriber's link circuits. This test circuit is of the portable wagon type and connects to the link circuits by inserting the plug of a test cord into the individual test jacks on the link frame. Two test lines are associated with each sub-group of links and when a start key is operated the district finder of the link under test starts upward. The test lines connect to the last two sets of terminals in the bank. When the first one of these lines is reached, a relay in the test circuit operates, putting the most severe busy condition on the first line and putting a severe idle condition on the next set of terminals. The district finder should stop on the second line. When the link has also selected an idle sender, a code is dialed so as to advance the sender far enough to complete the link test. When completed an "O.K." lamp lights, or if the link fails to operate properly the circuit is blocked; the nature of the trouble is indicated in the usual way.

Testing Pulse Machine

A separate test frame is provided for use in testing pulse machine leads. The pulse machine automatic test circuit connects to the pulse machine leads one at a time; it receives pulses to operate register relays while the pulse machine is in regular service without interfering therewith. If the correct registration is received the test circuit is advanced to the next sending drum. The connection to the different drums is made by the rotation of sequence switches. The six receiving drums are tested each time a sending drum is tested. Failure to operate the proper register relays stops the test circuit and brings in an alarm. If no trouble is encountered, one operation of the Start key causes the test circuit to make a complete test of all leads 20 times in succession before coming to a stop.

Testing Subscriber's Lines

A wagon type test circuit is used in making line and cut-off relay tests, voltmeter tests, and insulation breakdown tests on subscribers' lines. This test set is shown in Figure 6. Special final selectors are used in connecting to the subscriber's lines, the test circuit being connected to the final selector by means of cords and plugs inserted in jacks on the final frame. These

selectors are used in regular service when not used as test selectors. The final selector is driven upward under control of the test circuit to a particular line or to each line in succession. All of the tests or a particular test may be made on each line. Lamps indicate the progress of the test.

Certain Other Test Sets

A coin control test set is provided for testing coin control circuits in offices rendering coin line service on a mechanical basis.

Since a very large number of 200 type selectors are used in a panel office, a test set has been developed for use in testing and adjusting these selectors. The tests made include high and low voltage step and running tests.

Tripping relay adjusting sets have been developed for use in testing and adjusting tripping relays in trunk and incoming selector circuits. These sets provide for testing the relays on ringing current in such a way that the test is applied when at a certain point in the ringing voltage wave. This is called the "particular part of the wave" method of testing and insures a very much more uniform adjustment on tripping relays.

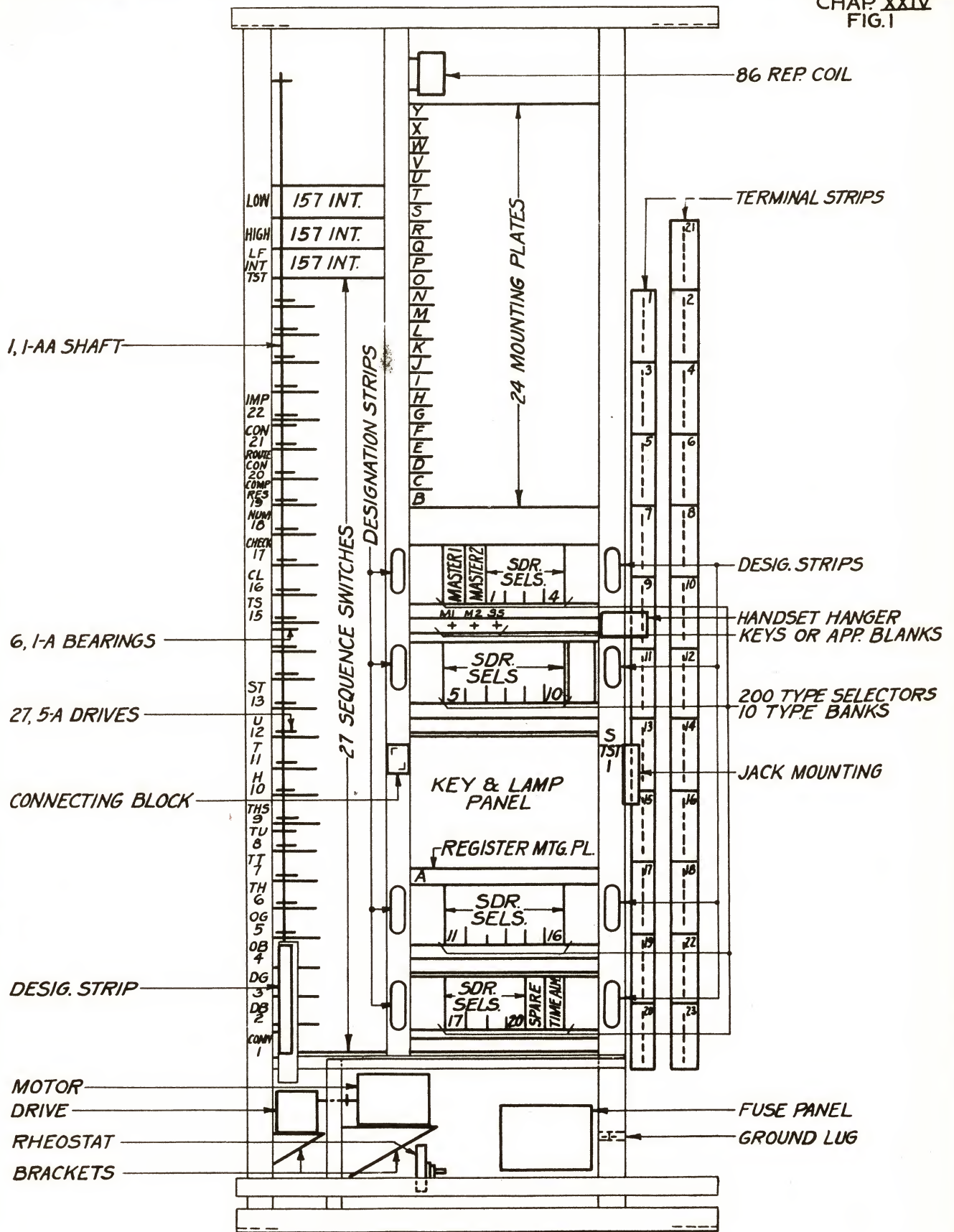

3 DIGIT SUBSCRIBER'S SENDER TEST FRAME
 FIG. 1

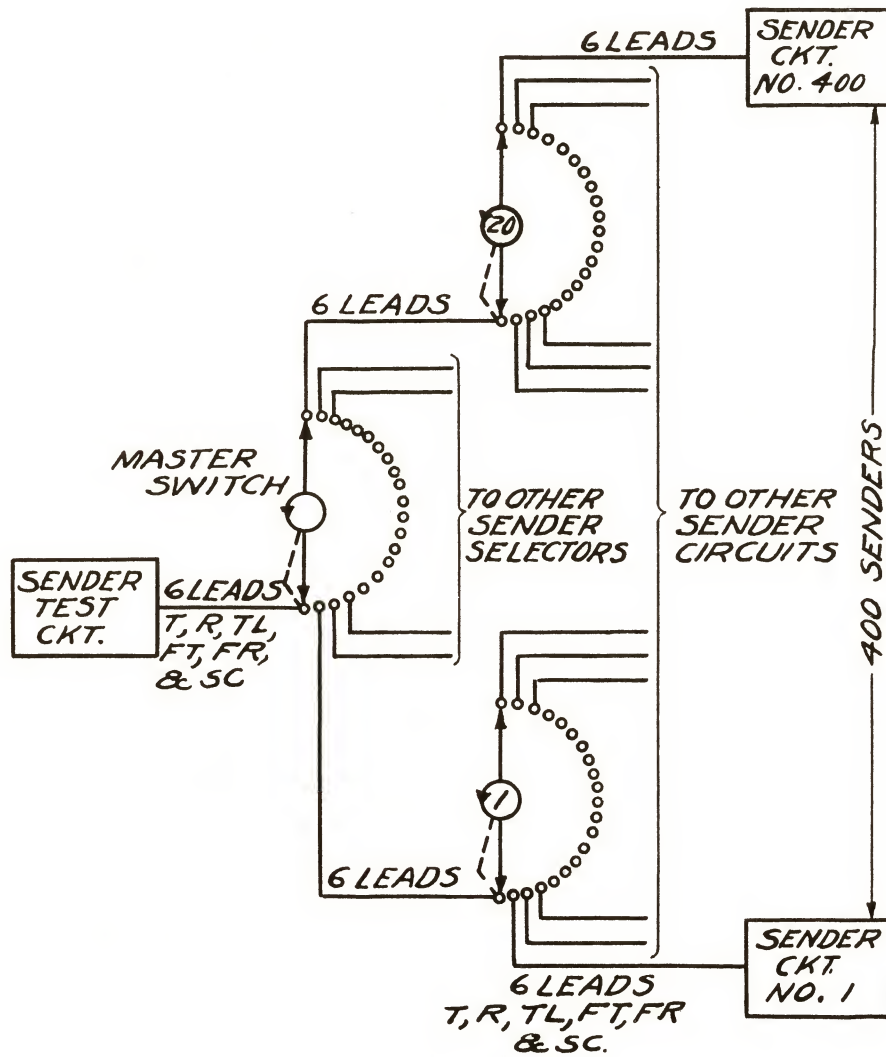

SCHEMATIC ARRANGEMENT FOR CONNECTING TEST
CIRCUIT TO THE VARIOUS SENDER CIRCUITS
FIG. 2

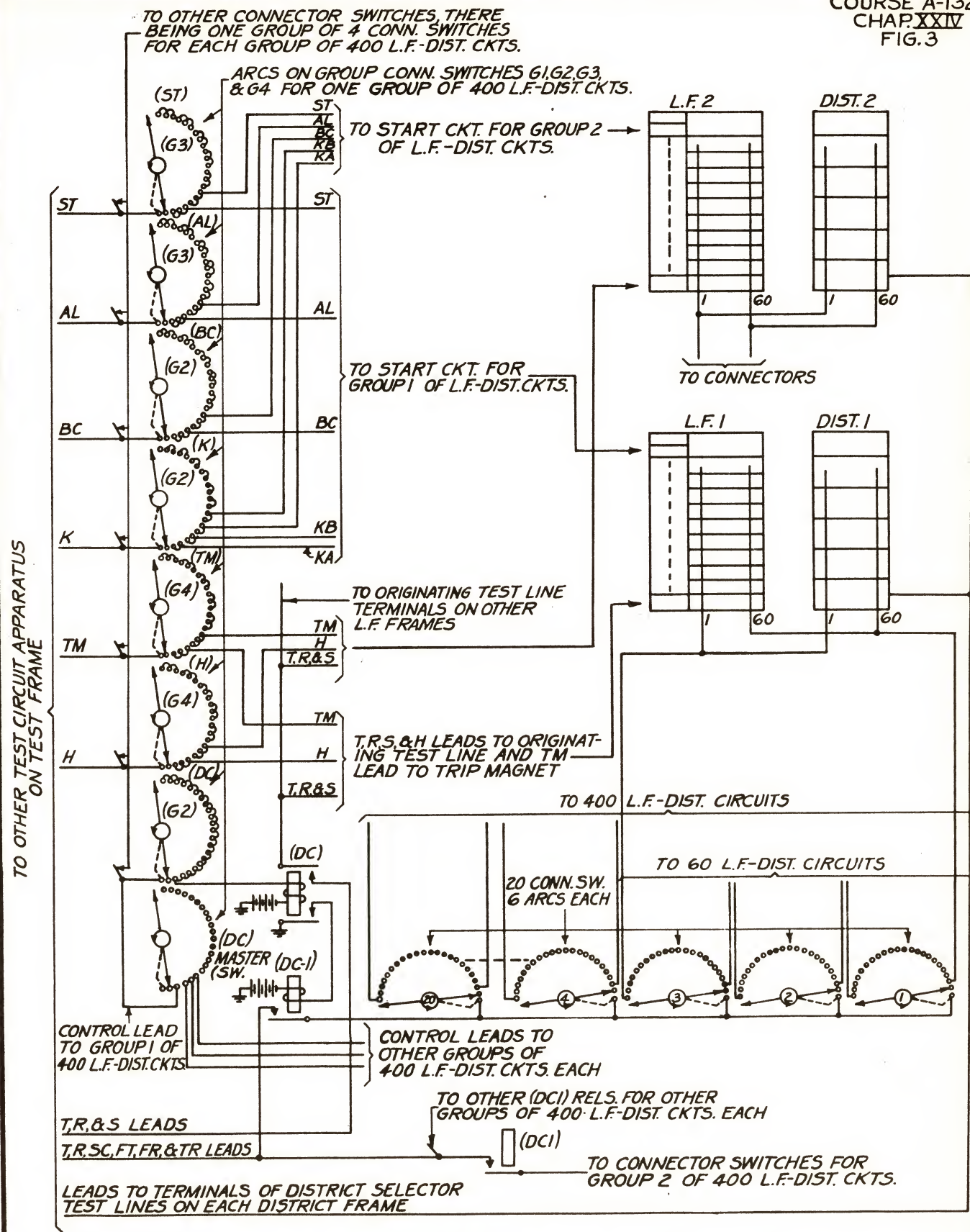

SCHMATIC ARRANGEMENT FOR CONNECTING
 THE ROUTINE TEST CIRCUIT TO THE LINE FINDER-DISTRICT CIRCUITS
 FIG. 3

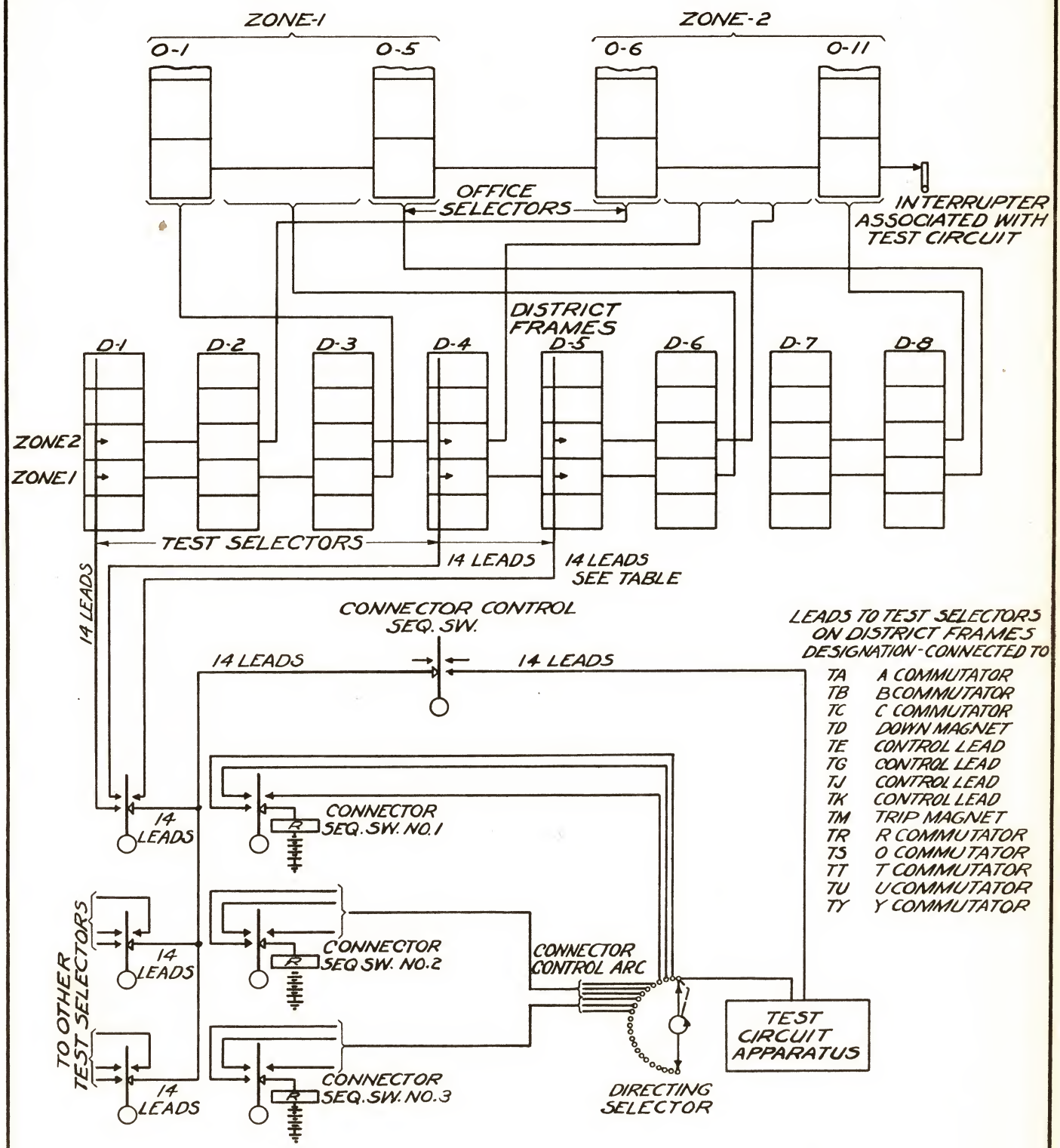

SCHMATIC ARRANGEMENT FOR CONNECTING TEST CIRCUIT TO THE VARIOUS 3 WIRE OFFICE SELECTOR CIRCUITS
 FIG. 4

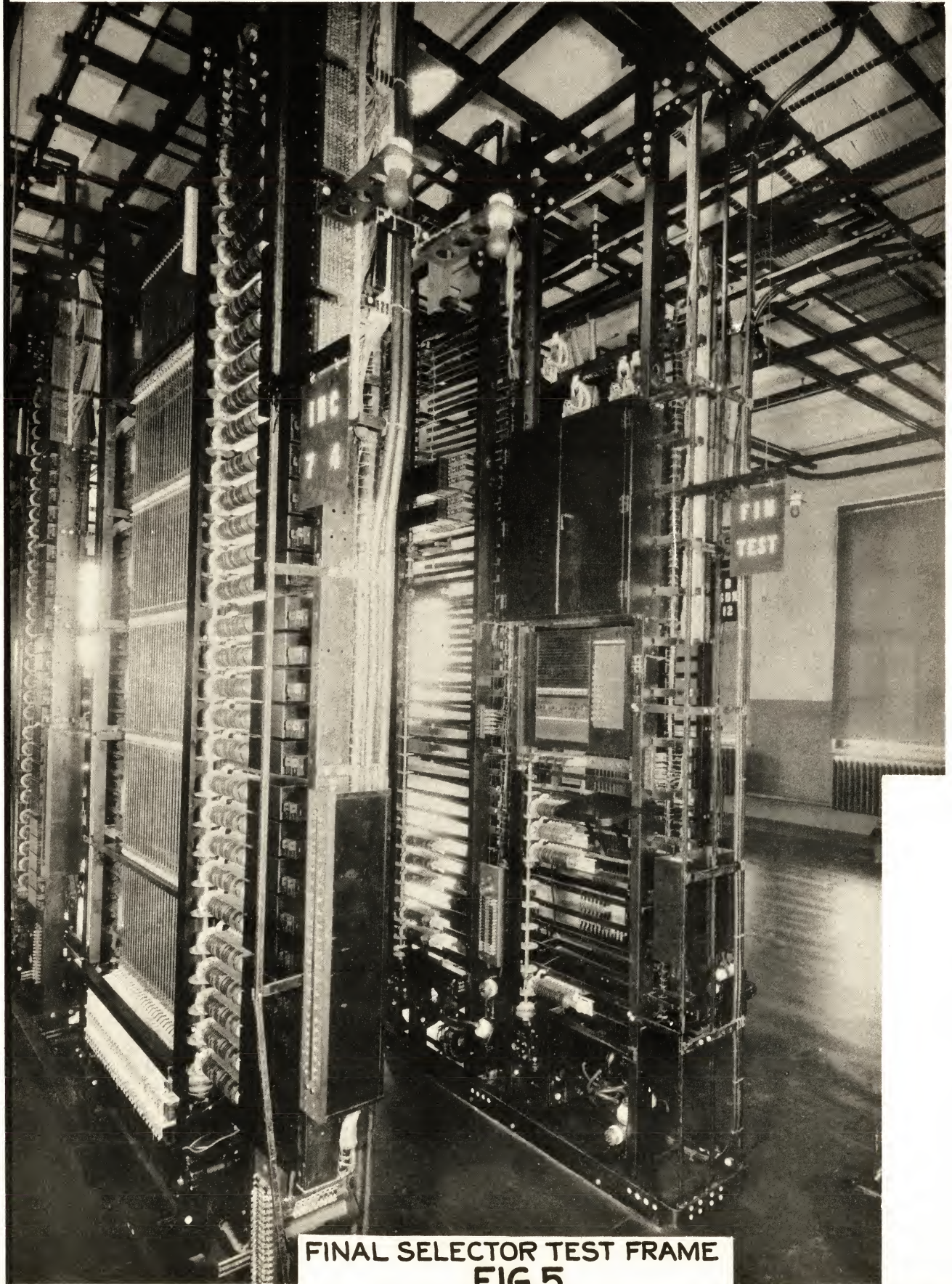

FINAL SELECTOR TEST FRAME
FIG. 5

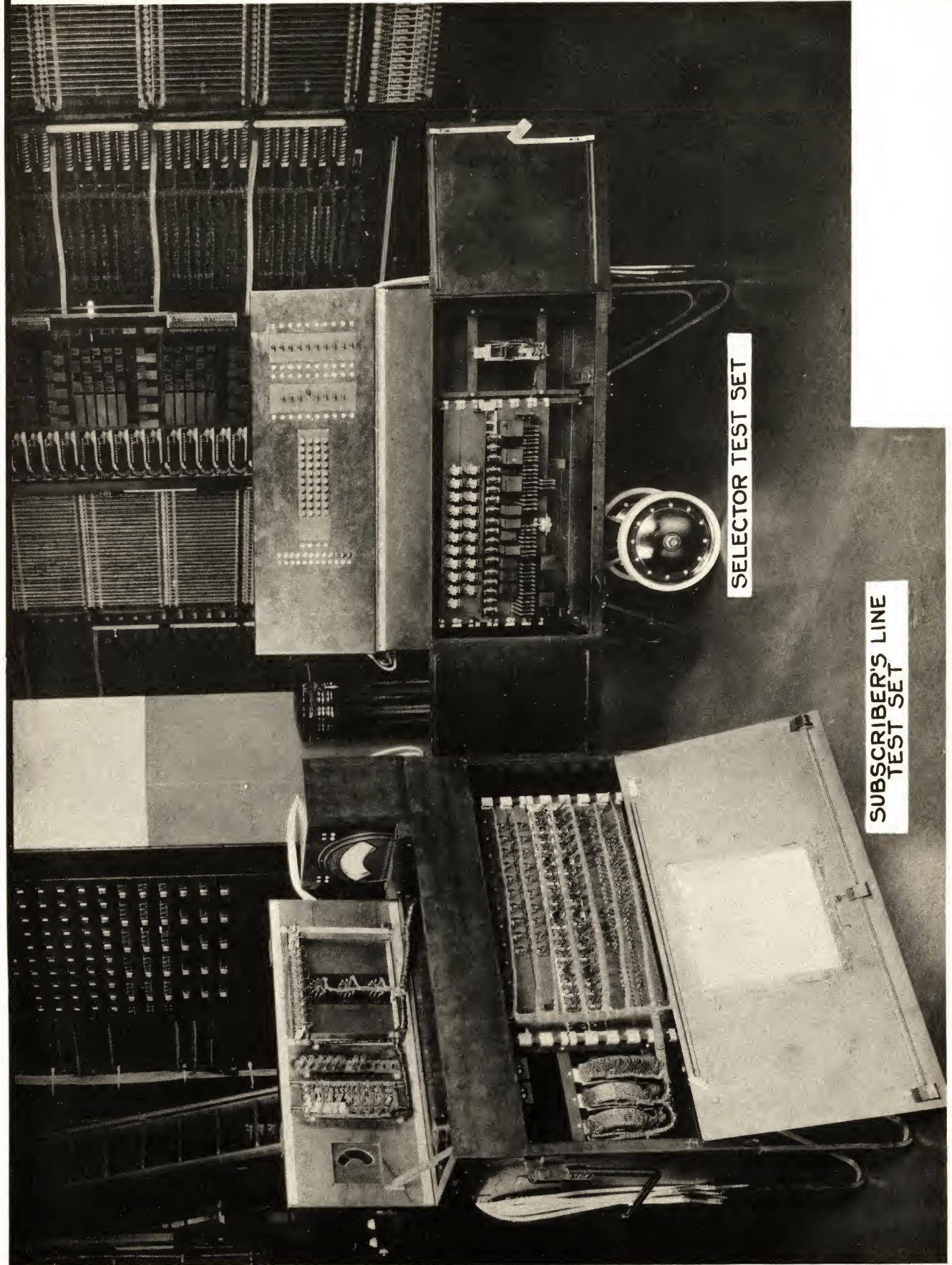

SELECTOR TEST SET

SUBSCRIBER'S LINE
TEST SET

WAGON TYPE TEST SETS
FIG. 6

CHAPTER XXV

POWER EQUIPMENT

The telephone power plant consists; (1) of equipment which transforms the commercial power supply obtainable in the particular area in which the telephone office is located into the forms required by the telephone equipment; (2) of stand-by or reserve equipment for supplying the power when the outside power supply fails, and (3) of such control equipment as is necessary in distributing this power and in insuring continuous telephone service. The forms of power commonly required in a Panel system office are:

Commercial power service (usually 60 cycle alternating current) at suitable voltages for operating the charging motor generator sets, the motor generator sets for supplying ringing current, frame drive motors, regular frame lighting equipment, and for driving other miscellaneous motors serving both the power and frame equipments.

Direct current regulated within definite voltage limits for operating signalling circuits, message registers, coin control circuits, power driven switches, frame drive motors during failure of the outside power service, and for emergency lighting equipment.

Direct current regulated within required voltage limits, the characteristics of which are maintained in such a way as to be suitable for use in talking circuits.

Direct current interrupted to produce tones for signalling, such as dial tone line, busy tone, etc.

Alternating current at 20 cycles per second and within definite voltage limits for ringing subscribers bells and for other miscellaneous purposes.

The power equipment in a Panel system office includes storage batteries, motor generator sets and rectifier units for charging the batteries, motor gen-

erator sets for supplying ringing and coin control current, drive motors, and emergency power generating equipment. The control equipment includes generator switch panels, a main control board, a battery control board, battery distributing fuse panels, a ringing power board motor, distribution boxes, and a power service board.

Due to its weight, the power equipment has, in the past, been located in the basement of the telephone building but in recent years and in some cases a more economical wiring arrangement has been secured by locating the power plant on upper floors of the building. The storage batteries are located in a battery room separate from the other power equipment so as to confined the acid spray during periods of charging. The battery charging equipment is located in a machine room adjacent to the battery room and a Battery Control Board is usually located in the machine room parallel to the wall separating the battery and machine rooms. Large bus-bars coming through sealed opens in the wall connect the batteries to the switches and fuses on the control board.

Connection between the charging generators and the batteries is provided by an overhead bus-bar system to which each generator is connected by means of a vertical riser. A generator control panel is located alongside of each generator and adjacent to each motor is located a starting compensator. A part of the equipment used in controlling the charging generators is located on these individual generator panels and the remainder is located on unit generator and instrument panels which are assembled together and called the Main Control Board; the Main Control Board is usually lined up at one end of the Battery Control Board.

The ringing current motor generator sets are sometimes located in the same room with the charging machines in which case the Ringing Power Board may be lined up with the Main Control Board but in many cases it is found desirable to locate the ringing machines on another floor of the building and the Ringing Power Board is adjacent.

The discharge leads carrying the battery current from the Battery Control Board to various Battery Distributing Fuse Panels are carried by an iron cable rack of the type used for telephone switchboard cables which terminates above and at the rear of the Battery Control Board. The Battery Distributing

Fuse panels are located on the various floors of the building near the equipment frames which are to be supplied therefrom.

STORAGE BATTERIES

Generally speaking, the switching and signalling mechanisms in a Panel type office are designed to operate within a voltage range of from 45 to 50 volts DC. and the local talking circuits are designed to operate within a voltage range of from 21 to 25 volts. To fulfill these conditions 12 cells of the Electric Storage Battery Company's chloride accumulator type are connected in series to supply the 24 volt load, and 12 additional cells are connected in series with the first 12 to supply the 48 volt load. Thus, the 12 cells which carry the 24 volt load are known as the 24 volt battery and must be large enough to carry the current for both the 24 and 48 volt loads; the other 12 cells known as the 48 volt battery carry only the 48 volt load.

Two sets of batteries are provided, the 24 volt batteries being designated 1-A and 1-B and the 48 volt batteries designated 2-A and 2-B. The cells are arranged in eight 6-cell groups, 4 groups on each side of a center aisle over which the battery bus bars and leads are supported. The grounded or positive end of the battery having the combined 24 and 48 volt load to carry is located nearest the battery control board. The 6-cell groups are arranged with their long dimensions parallel to the battery control board so as to keep the 24 and 48 volt leads as short as possible. Figure 6 will help to visualize the arrangement of the cells.

The plates used in these cells are of rugged construction suitable for use in standard batteries and are of 2 sizes, G and H. The G plate is approximately 15" wide and 15" high and the H plate is approximately 15" wide and 30" high, so that the H plate can carry twice as much current as a G plate without occupying any more floor space. The plates are assembled in lead lined wooden tanks which are of a length sufficient to accommodate the ultimate number of plates which will be required; if the load at the time of installation is less than the ultimate only emf plates are installed as are required to carry the initial load, the remaining space being filled by non-active lead alloy displacement tanks.

To avoid the rapid discharge of the battery during hours of heavy

traffic, one or more charging generators are connected in parallel with the battery so that the office load is carried by the generators and the batteries which are said to be "floating" act as voltage regulators and are charged or discharged only in such a degree as is necessary to smooth out the fluctuations in load and voltage. In offices where the load is fairly heavy even in the light-hour periods the batteries are floated over the 24 hour period this being known as "full floating". In offices where the load during the light-load periods is so small that it would be uneconomical to operate the charging generators (or mercury arc rectifiers, when furnished) the load is taken from the batteries during the light-load periods and the batteries are floated only during the heavy load periods in which case they are recharged to the extent that they have been discharged during the light load period; this is termed "partial floating".

By the use of the floating method of carrying the office load the batteries are kept in a charged condition, the losses due to battery inefficiency are minimized, the life of the battery is increased since they are not subject to the alternate cycles of charge and discharge, and the discharge voltage can be very closely regulated during the floating period.

Storage cells are periodically overcharged, the chemical action attending charge being thereby thoroughly completed in order that the batteries be kept in good operating condition. At the end of overcharge the cell has an average voltage of 2.16 volts; but, as soon as load is connected and the cell begins to discharge, the voltage drops to approximately 2.10 volts. The minimum voltage when completely discharged is about 1.75 volts. Since the maximum charging voltage very much exceeds the maximum discharge voltage, it would be impossible to keep the voltage at the battery distributing fuse panels within the required limits if the batteries were charged while in service. By providing the 2 sets of batteries as mentioned previously, one set may be given the overcharge while the other is in service.

The leads furnished from the batteries to the distributing fuse panels are of such size that the voltage drop in the 48 volt leads will not exceed 2.25 volts; and, to maintain a minimum of 45 volts at the distributing fuse panels, the voltage at the battery control board cannot fall below 47.25 volts. Since the maximum discharge voltage of 24 cells in series is only 50.4 volts

(24 x 2.1 volts) the average voltage per cell could be reduced only to about 1.97 volts even though less than half of the energy stored in the cell (when fully charged) had been discharged. This is of no importance during normal operation but in case of a total power failure the telephone equipment would fail to give service on account of insufficient voltage as soon as the average voltage per cell fell below 1.97 volts. To make it possible to use all of the energy remaining in the cells 3 booster or emergency cells are provided which may be connected in series with the 48 volts battery, one at a time; the voltage does not, therefore, fall below 45 at the fuse panels volts until the 24 regular cells have been fully discharged. For the same reason one emergency cell is provided for the 24 volt battery, the discharge leads from this battery being of such size as to limit the voltage drop between the battery and distributing fuse panels of 1.75 volts.

The emergency cells are normally kept in a charged condition by connecting them in series with the loads which are being floated. The 48 volt emergency cells can also be charged directly by the charging generators, switching arrangements being provided to connect the batteries for these conditions. The 24 volt emergency cell cannot be charged directly from the generators since it is not feasible to sufficiently reduce the generator voltage.

The fixtures of the room containing a large battery are subject to considerable sulphuric acid corrosion. Any condensation on the walls, bus bars, superstructure or other fixtures forms a sulphuric acid solution which makes necessary the use of special acid resisting paint to protect the equipment. Steam pipes, water pipes and conduits are therefore excluded as far as possible from the battery room. Battery bus bars are run over the aisles rather than over the tanks and in order that there be as few flat surfaces as possible on which condensation can collect a special pipe superstructure is used to support the bus bars. Even with these protections the coating of acid resistance paint has to be renewed about every 2 years.

BATTERY CONTROL BOARD

On the panels of the battery control board are mounted (1) the battery charge and main discharge fuses, (2) small alarm type fuses which are in parallel with the main fuses, (3) switches used in connecting the office load to either battery or to both in parallel, (4) switches used in cutting in or cutting out

the emergency cells, and (5) shunts used with the ammeter on which the charge or discharge load is indicated. The charging fuses are of the open link type and range in capacity from 650 to 9600 amperes. The main discharge fuses are of the cartridge type and are furnished in duplicate so that by throwing a single-pole double-throw knife-switch the load can be transferred from one fuse to the other. This arrangement permits the immediate restoration of service without replacing the fuse, providing the failure was caused by a momentary overload or by a weak fuse. Alarm type fuses are placed in parallel with the main fuses and arranged to close an audible alarm circuit when they operate; they also give a visible indication to assist the attendant in locating the main fuse which has operated.

The battery transfer switches are single-pole double-throw knife-switches of the circuit maintaining type, ranging in capacity from 200 to 6000 amperes. They are arranged so that the two 24 volt sections of the battery can be connected in parallel and so that the two 48 volt sections of the battery can be connected in parallel, when load conditions require. The emergency cell switches are mechanically interlocked so that the cells can only be cut in or cut out in the proper sequence; mistake in operating these switches and consequent interruption of service, in the excitement caused by a power failure, is thus prevented.

BATTERY DISTRIBUTING FUSE PANELS

The leads from the discharge fuses at the battery control board feed bus bars on the rear of the distributing fuse panels on the various floors, these panels being centrally located with respect to the equipment frames which are to be supplied. The distributing fuse panels are assembled in one or two bays as required, there being one cartridge type fuse mounted on the front of the panel for each branch lead which feeds a row of equipment frames. The branch leads of braided rubber covered wire are run on top of, or on the underside of, switch-board cable racks and each lead is run down the end of the first frame in the line of frames which it feeds; the lead then continues under the line of frames taps being taken off at each frame to feed the individual frame fuse panels. With each of the cartridge type fuses is associated an alarm type fuse whose operation when the cartridge fuse is blown closes an audible alarm circuit and lights a lamp at the floor alarm panel; the alarm fuse also gives a visual signal to aid the attendant in locating the fuse which has burned out.

BATTERY CHARGING EQUIPMENT

The generators provided for charging the batteries and carrying the DC load vary in rated capacity from 175 to 1500 amperes at 33 volts and from 175 to 800 amperes at 65 volts. The 65 volt generator capacity is large enough to float the 48 volt busy-hour load, and may be supplied by one generator alone or by several operating in parallel. The 33 volt generator capacity is large enough to float the 24 volt busy-hour load and may be supplied by one or more generators. A 65 volt generator large enough to replace the largest 33 or 65 volt generator is furnished in addition, as a reserve machine, and can be used for charging either the 48 volt or 24 volt batteries. The generators are direct connected to either AC or DC motors depending upon the outside source of power; if AC, these motors may be either of the induction or synchronous type in accordance with the requirements of the power company supplying the power.

A special telephone generator termed the "M" type has been used in the past since the ordinary commercial DC generators were too noisy to float batteries which supplied talking circuits. The "M" type generator is surface wound (instead of slotted) to do away with slot ripple in the generated voltage. The commutator is made up of 4 or 5 times the number of bars used in commercial practice and copper gauze brushes are used to reduce the noise due to commutation. The generators shown in figures 1 and 2 are of the "M" type and driven by AC induction motors.

Commercial generators are now used instead of the "M" type generator but it is necessary to use a filter circuit to eliminate the machine noise from the talking circuits. The filter consists of large electrolytic condensers and large choke coils which are placed in the discharge leads which carry the talking load. A commercial generator is shown in figure 3.

Mercury arc rectifiers are used in some offices for carrying the office load during light load periods, when it is uneconomical to operate the motor generator sets. These rectifiers have a capacity of 50 amperes and are of the auto-starting type.

In order to keep the generators, which are being used to float the load, within the required floating voltage range, a voltmeter relay is connected in parallel with the voltmeter, so that if the voltage varies outside of the

allowable limits the relay operates and actuates an alarm bell. When the alarm is given the attendant readjusts the generator field rheostats to correct the voltage. In offices where considerable variation in load is encountered the adjustment of the field rheostats is made by an automatic voltage regulator of the contact making voltmeter type; the field rheostats are driven by motors which are governed by the voltage regulator. The regulator is usually set to operate on a ± 0.5 volt variation on the 48 volt load and ± 0.25 volt variation on the 24 volt load.

GENERATOR CONTROL EQUIPMENT

The generator control is of a type known as the "Semi-remote System of Generator Control". A motor starting compensator is mounted on the sub-base adjacent to each motor and an individual generator control panel is located adjacent to each generator, as shown in figures 1 and 2. On the generator panel is mounted a solenoid-operated air circuit breaker, with overload and reverse current protection. Each of these circuit breakers is closed or opened by the operation of a switch at the main control board; when closed, the leads from the positive brushes of the generator are connected through the overload coil to ground. A single-pole double-throw knife-switch is also mounted on this panel, so that the leads from the negative brushes of the generator can be connected to that one of the two batteries which is to be floated or charged; vertical risers from the panel connect to the main charging bus bars which are run overhead, as shown in Figure 2. Figures 1 and 2 show the generator field rheostats mounted adjacent to the generators, these rheostats being motor driven and controlled from the main control board; but the standard method is to mount each field rheostat on the rear of a unit panel at the main control board, and it is adjusted manually by a handwheel on the front of the panel.

On the main control board are mounted the control switches, for operating the air circuit breakers, and all the supervisory equipment used in connection with control of the charging generators after they are running and connected to the battery to be floated or charged. This equipment includes battery ammeters, voltmeters, individual generator field rheostats and ammeters, and pilot lamps which indicate the battery to which each generator is connected; it is mounted on unit type meter and generator control panels. Rectifier panels may

be included with the main control board if mercury arc rectifiers are furnished. a 3-pole double-throw service switch which is used to connect the motors of the charging generators to either the line power or an emergency power supply is mounted on one of the lower panels of the main control board; 3-pole double throw duplex motor switches are mounted on another of the lower panels, these switches being used to connect the duplex motors to the line power supply.

When synchronous motors are used for driving the generators an AC service voltmeter, an associated instrument switch, a power factor meter and an exciter field rheostat are mounted on panels at the main control board; and, when automatic voltage regulators are used, the control switches for the regulators are mounted on a unit panel at the main control board.

When a generator is to be started the attendant operates the starting compensator associated with the motor of this set, thus starting the motor; the single-pole double-throw knife switch is thrown to the position in which the generator is connected to the battery which is to be charged. The attendant proceeds to the main control board, adjusts the generator voltage by turning the field rheostat handwheel, and then operates the remote control switch to the "close" position, thereby causing the circuit breaker on the generator panel to close the generator circuit. If several generators are to be put into service they will all be started and connected to the battery to be charged or floated; then each one is connected to the load, after adjusting its voltage, by operating the remote control switch. To shut down a generator the load is taken off by reducing the voltage generated and the remote control switch is then operated to the "open" position, causing the circuit breaker to open the generator circuit. The attendant proceeds to the generator switch panel, opens the generator switch and stops the motor by operating the release switch on the compensator.

RINGING AND COIN CONTROL GENERATORS

For supplying 20 cycle ringing current and for supplying direct current for coin control circuits, a special generator is used whose armature has a commutator on one end, from which the direct current for the generator field and for coin control circuit operation is taken, and slip rings at the other end, to which the alternating current ringing load is connected. The generator is direct connected to two motors, a line driven motor and a battery driven motor.

Upon failure of the outside service the battery motor takes the load due to the operation of automatic control circuits, and an alarm is given to indicate this condition. When the outside power is restored the contactors in the automatic control circuit disconnect the battery motor and the line driven motor again takes up the load. The motors driven from the outside power supply are usually fed through a master switch associated with the duplex panel-frame drive motors, the leads being separately fused at a motor distributing box when possible. The battery motors are fed directly from a panel at the battery control board or from a battery distributing fuse panel, depending upon whether the ringing machines are, or are not, located in the same room with the charging generators.

At least two sets of ringing machines are provided so that service will not be interrupted when one set requires cleaning or repair. When two sets are required to carry the office load, one additional set is furnished for reserve, all three being of the same size. The generators are driven at a rated speed of 1200 rpm and generate about 155 volts AC at the slip rings. The slip rings are connected to the winding of a transformer which is mounted under the machine table or on the rear of the ringing control board. The transformer has four unregulated voltage taps at ranges of from 69-83 volts, 77-91 volts, 92-106 volts, and 97-111 volts. The load is connected to the proper voltage tap and the voltage on this tap is regulated by means of a voltage regulator which controls a pair of contacts bridged around part of the resistance in the generator field circuit. The contacts of a centrifugal type speed regulator which is mounted on the end of the shaft perform a similar function in the field circuit of the battery driven motor. By these regulating devices the output voltage is kept within limits of +3 and -5 volts AC and ± 10 volts DC. Thus, the AC voltage supply for individual, 2-party selective, and 4-party semi-selective ringing is regulated between 95-103 volts; and for 4-party selective ringing it is regulated between 72-80 volts; the coin control voltage is regulated between 100-120 volts.

The two-motor ringing and coin control sets are furnished in two sizes, P-1 and P-2, each of which with its transformer is capable of delivering the output shown in the following table:

Unregulated Voltage Range		Type P-1 Ampere Output		Type P-2 Ampere Output	
<u>AC</u>	<u>DC</u>	<u>AC</u>	<u>DC</u>	<u>AC</u>	<u>DC</u>
97-111	100-120	3.0	0.38	6.0	.5
69-83	100-120	4.0	0.38	8.0	.5

Each ringing machine includes two sets of interrupter rings. One set is known as the high-speed interrupter and is mounted on the same shaft with the generator; the other set, which is known as the low-speed interrupter is mounted at right angles to the generator shaft and geared to it by a 120:1 reduction gearing.

The high-speed interrupter consists of four rings, two of which are solid and two of which are divided into metal segments separated by insulation. A brush rests on each of the solid rings and feeds 24 volt battery to alternate metal segments of the split ring with which the solid ring is associated. One of the split rings is divided into 16 segments and the other into 48 segments. Three brushes 120° apart rest on each of the split rings and each of these 3 brushes is thus connected to 24 volt battery 160 times per second and supplies "low tone" which is used for "dial tone", "line busy tone" and "all paths busy tone". Each of the 3 brushes on the other split ring is connected to the 24 volt battery 480 times per second and supplies "high tone" which is used as the "checking tone" at the special service positions of the MS "A" board and also as the "howler" which is applied to subscribers lines by the sender monitor when the receiver has been left off the hook at subscribers stations.

The low-speed interrupter is also an assembly of split and solid rings so arranged as to interrupt the 20 cycle alternating current for machine ringing and to apply 60 volt tripping battery on the line during the silent interval. In individual 2-party selective, and 4-party selective offices a set of two solid rings and one split ring provides a ringing interval of 2 seconds followed by a silent interval of 4 seconds; in 4-party semi-selective offices one split ring provides a ringing interval of 2 seconds followed by a silent interval of 4 seconds, this being known as the R-1 or one ring code, and another split ring provides in the order named, a ringing interval of one second, a silent interval of one second, a ringing interval of one second and a silent interval of three seconds, this being known as the R-2 or two ring code. Each of the split rings has 3 brushes resting thereon spaced 120° apart so that the ringing load is

divided into 3 parts, $1/3$ of the load being carried by each brush.

For 4-party selective ringing one set of 3 rings is used to supply the 3 brushes which rest on the split ring with ringing current on which is superimposed a +DC current, and another set of 3 rings is used in a similar manner to superimpose negative battery upon the AC ringing current.

For 4-party semi-selective ringing a set of 2 solid rings and one split ring is provided for controlling the beginning of ringing when the called station is rung by the two ring code, these rings being known as the "pick-up interrupter". The split ring is divided into 2 segments and the brush resting thereon is connected, first to the one and then to the other for 3 second intervals. The brush on one of the solid rings feeds pick-up ground to one of the metal segments on the split ring, and the brush on the other solid ring feeds 48 volt battery (supplied through the winding of a pick-up alarm relay) to the other metal segment of the split ring. Each of the 3 brushes on the split ring thus supplies pick-up ground to the various incoming selector circuits for 3 second intervals each followed by a 3 second test of the pick-up leads for a false ground.

RINGING POWER BOARD

The equipment provided for controlling the ringing and coin control motor generator sets is located on an assembly of unit type panels termed the Ringing Power Board. This board usually consists of 3 bays. On the panels in the first bay are mounted (1) the switches for starting and stopping the ringing machines, (2) the switches which automatically close the battery motor circuit when the line power fails and which open this circuit when the line power is again available, and (3) the voltage regulators; the equipment for each ringing machine is mounted on a separate panel. A voltmeter switch and switches for transferring the load from one machine to the other are mounted on the panels of the second bay. On the panels in the third bay are mounted an ammeter, the ringing battery control switches and rheostats, and the fuses in the ringing leads; on the rear of the panels in this bay is mounted miscellaneous ringing equipment which includes tone repeating coils, a choke coil for the battery driven motor and a filter for keeping the "howler" noise out of the talking battery. The ringing power board is located near the ringing machines and when these machines are in the same room as the charging generators the ringing board is usually lined up with the main control board.

RESERVE POWER PLANT

It is essential that means be provided in Panel System offices for supplying power temporarily in case of failure of the outside power source. The selector frame drive motors and ringing machines must be kept running, and when the power service fails they are automatically switched onto the storage batteries, which are large enough to carry the regular office load plus a 3-hour drive-motor load. It is expected that the line power can be restored within three hours, but reserve equipment sometimes known as "House Plant", is placed in operation as soon as the failure occurs even though the batteries have such a reserve. The House Plant usually consists of a gas engine-driven generator which generates electrical power of the same characteristics, either AC or DC, as the power service for which it is substituted; or it may consist of gas engine-driven charging generators of such a size and number as is required for charging and floating the batteries. Other types of emergency equipment are provided when required by varying power supply conditions. The control equipment for House Plant is located on a separate control board unless the generator or generators are located in the same room with the regular battery charging generators, in which case the House Plant control panels may be in the same line-up with the regular main control board. A gas-engine driven alternator may be seen in the back ground of Figure 2.

FRAME DRIVE MOTORS

The frame equipment in the Panel system is operated by 1/16 horse power motors which are normally driven by the regular line power (either AC or DC as the case may be) but driven by the 48 volt battery in emergencies. They are called "Duplex Motors".

The AC-DC Duplex Motor is in reality two complete motors, a shunt-wound DC and an AC induction motor enclosed in a single housing. A DC armature with its commutator is placed on one end of the armature shaft and an AC rotor on the other end. With the DC armature is associated a DC shunt field, and with the AC rotor is associated an AC stator winding. The brushes of the DC motor are normally held away from the commutator by springs, but when the outside power fails, the release of an AC relay closes the DC shunt field and energizes a brush closing magnet which pulls the DC brushes down against the commutator. On

restoration of the AC power the AC relay reoperates opening the DC shunt field and deenergizing the brush closing magnet so that the DC brushes are pulled away from the commutator. The transition from AC to DC, or vice versa, is accomplished without appreciable variation in the motor speed. Notice of outside power failure is given by the ringing of a bell, and lighting of a lamp in a power alarm cabinet. The construction and operation of a DC/DC Duplex Motor is similar to that of the AC/DC motor described.

The motors are mounted on brackets by means of a clamping arrangement the motor shaft being fastened to the drive shaft by means of a pin coupling. When any motor becomes defective it can be removed by releasing the bracket clamp and pulling the motor out of place; the coupling pins merely pull out of their sockets when the motor is drawn out. The new motor is then slipped in and clamped. A plug ended cord attached to each motor provides for an electrical connection at a power supply socket.

Duplex motors rated at 1/12 horse power but otherwise of the same design as the frame drive motors described above are used for driving the pulse machines.

MOTOR DISTRIBUTION BOXES

The frame motors are supplied by separate leads from motor distribution boxes, there being one or more boxes on each floor located near the frames to be served. The boxes are designed to serve the ultimate number of motors on the floor and are similar in construction and wiring arrangement to a distribution box in a lighting system.

MASTER SWITCHES

The power supplied to the Duplex motors is brought through a relay and contactor device called a "Master Switch" which automatically opens and disconnects the line service in case of voltage fluctuation which would affect the speed of the frame drive motors or which would be likely to cause damage. The frame drive motors then automatically throw over to the battery supply. As indicated above, an alarm lamp is associated with each motor to indicate that it is operating on the battery, but at a time of power failure the master switch opens the individual lamp and alarm circuits and actuates its own visual and double alarm.

SERVICE BOARD

The outside power is supplied to a telephone office through a service board which provides such protection as is required by the power company and the Board of Fire Underwriters.

POWER ALARM SYSTEM

Throughout the power plant every safeguard is taken to minimize service interruptions and a system of power alarms is provided to notify the maintenance force when some trouble exists; the alarms thus operated help in locating the trouble, by giving both an audible and a visible signal. A large vibrating gong operated from the central office battery is used for the major alarms which cause interruption to service; and an ordinary subscribers ringer operated by the ringing machine is used for the minor alarms, those which are of lesser importance. The visible signals are switchboard lamps mounted behind numbered bulls-eyes in a cabinet termed the "Power Alarm Cabinet". This cabinet is located in a conspicuous place in the power room and a chart showing the lamp numbers and the alarms with which each is associated is fastened to the cabinet door. The lamps in a power alarm cabinet are multiplied at the main alarm board so that if trouble conditions are not cleared by the power man, action can be taken by others of the maintenance force. The main alarm was mentioned in a previous chapter.

FUSE ALARMS

In parallel with each battery discharge and ringing discharge fuse, there is connected a $\frac{1}{2}$ ampere 35-F fuse. This is a fuse of the "Grasshopper" type which energizes the alarm circuit and throws out an indicating bead upon operating. When the main fuse blows, the alarm type fuse also operates bringing in an audible and visible signal. The alarm fuse is either located adjacent to its associated main fuse, or numbered to agree with it so as to aid the attendant in replacing the blown fuses.

NO-VOLTAGE ALARMS

Ring and coin control service is subject to interruption by brush failures on the ringing and coin control generator or the associated interrupters. Continuously operated relays are therefore connected to the bus bars fed by each brush. These relays release and bring in alarms in cases of brush failures or other open circuit conditions.

FLOATING ALARMS

The floating alarms were mentioned in the section covering storage batteries. As indicated therein, when the floating limits are exceeded in carrying the 24 and 48 volt loads, voltmeter relays are operated and bring in audible and visible signals. A key is provided which cuts off these alarms when the floating routine is not in use.

HIGH-LOW VOLTAGE ALARMS

A voltmeter relay which is set to operate on wider limits than the 48 volt floating relay is connected to the 48 volt battery and causes an alarm to be given whenever the battery is outside the limits for satisfactory operation of the machine switching equipment.

MISCELLANEOUS ALARMS

The transfer of the ringing and coin control motor-generator sets to the battery supply is also covered by an alarm which is usually cut off by the operation of the master switch, so that the audible signal will not continue during a power failure.

Various other alarms are provided among which might be mentioned those associated with the charging generator circuit breakers and those which operate on the failure of a mercury arc rectifier.

LIGHTING EQUIPMENT

To assist maintenance of Panel equipments, it is necessary to provide a comprehensive system of overhead aisle lighting and to provide a number of plug receptacles conveniently located to which extension lights can be connected. The regular lighting equipment is supplied from the outside power source, but emergency lights located adjacent to the mechanical equipment are supplied from the storage batteries when the outside source fails.



CHARGING BUS BARS

MOTOR CONDUIT

RISERS

CONTROL PANEL

GENERATOR

CHARGING MOTOR-GENERATOR SETS
FIG.1

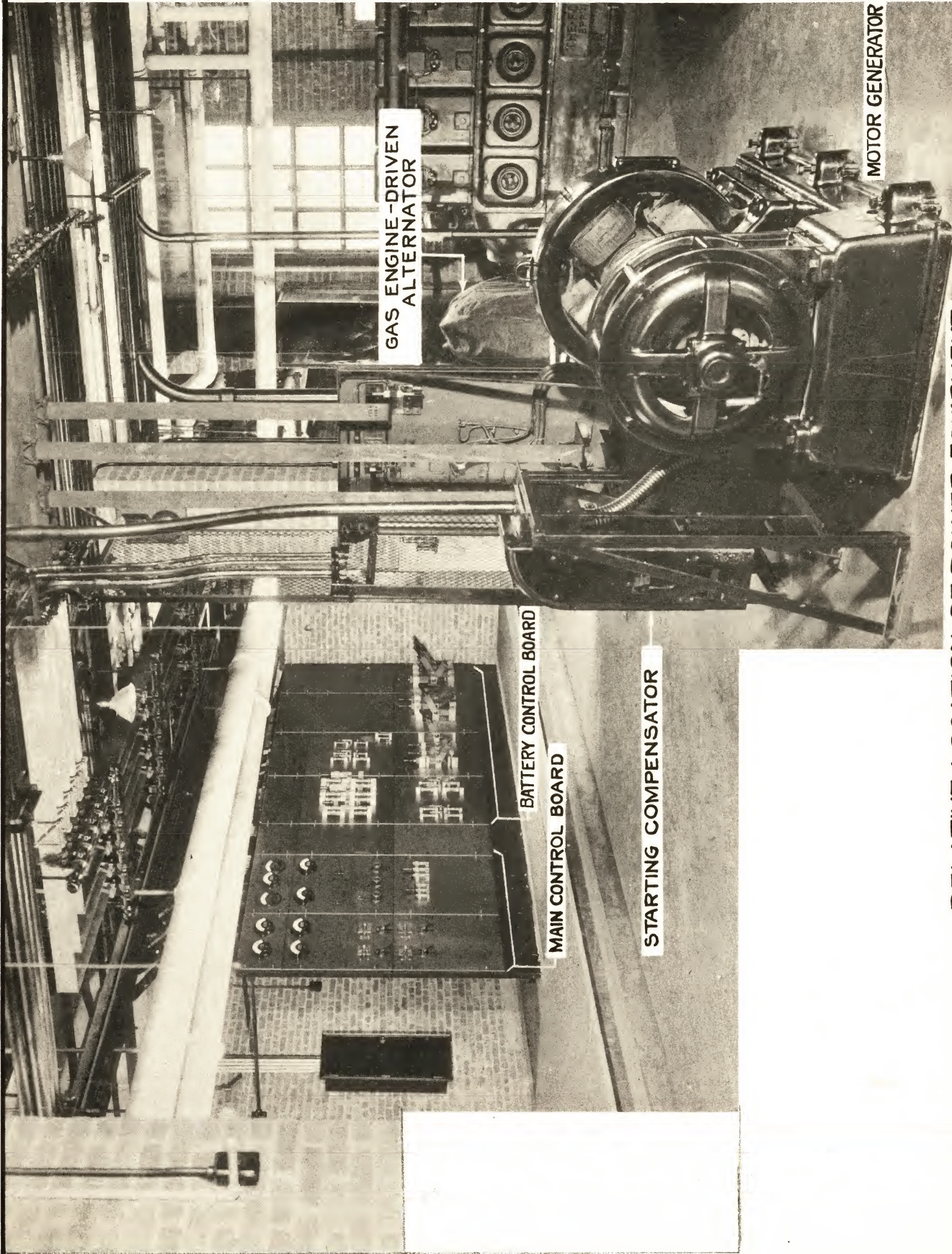

RELATIVE LOCATION OF POWER EQUIPMENT
FIG. 2

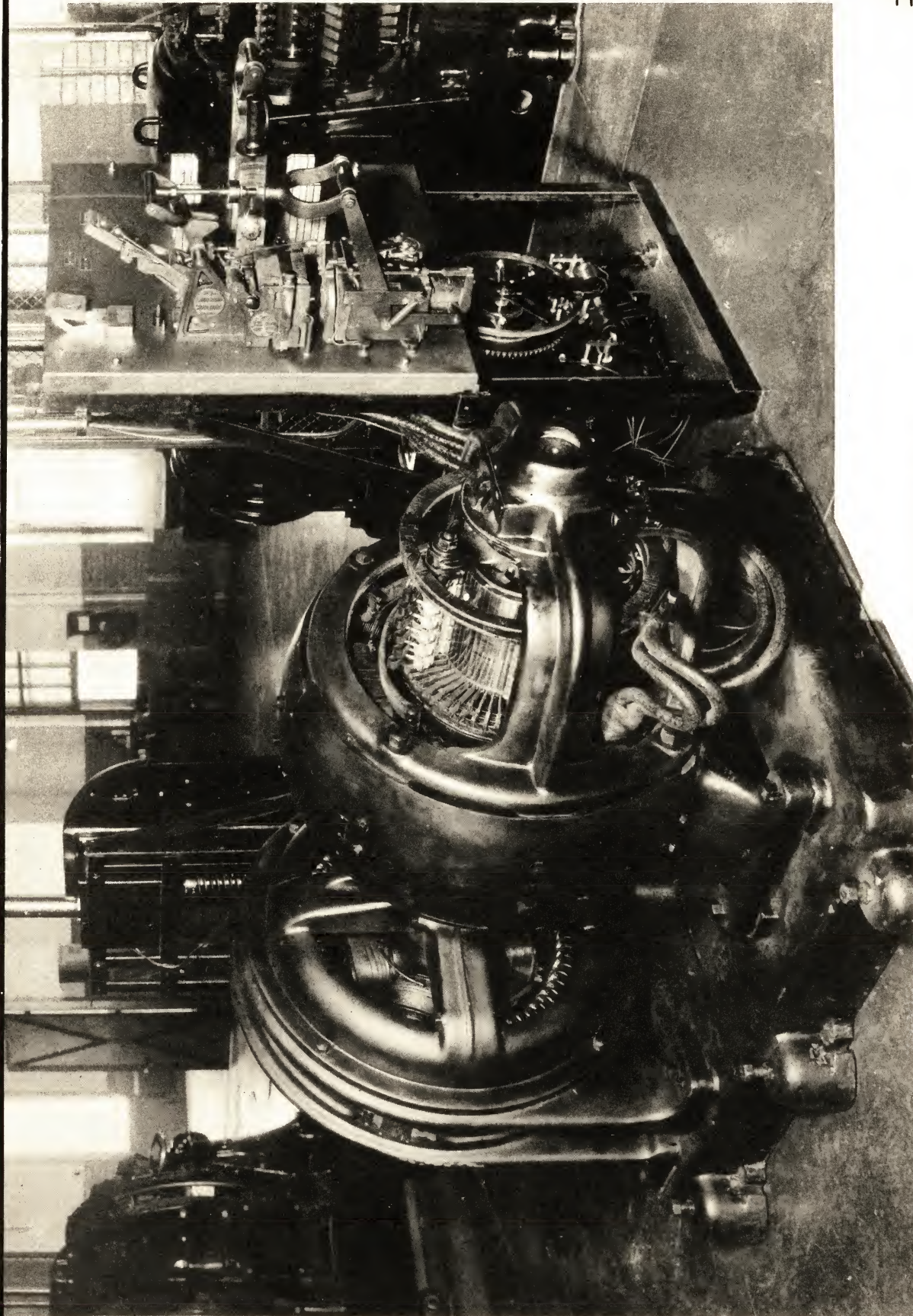

CHARGING MOTOR-GENERATOR SET
COMMERCIAL TYPE GENERATOR--SYNCHRONOUS MOTOR
FIG. 3

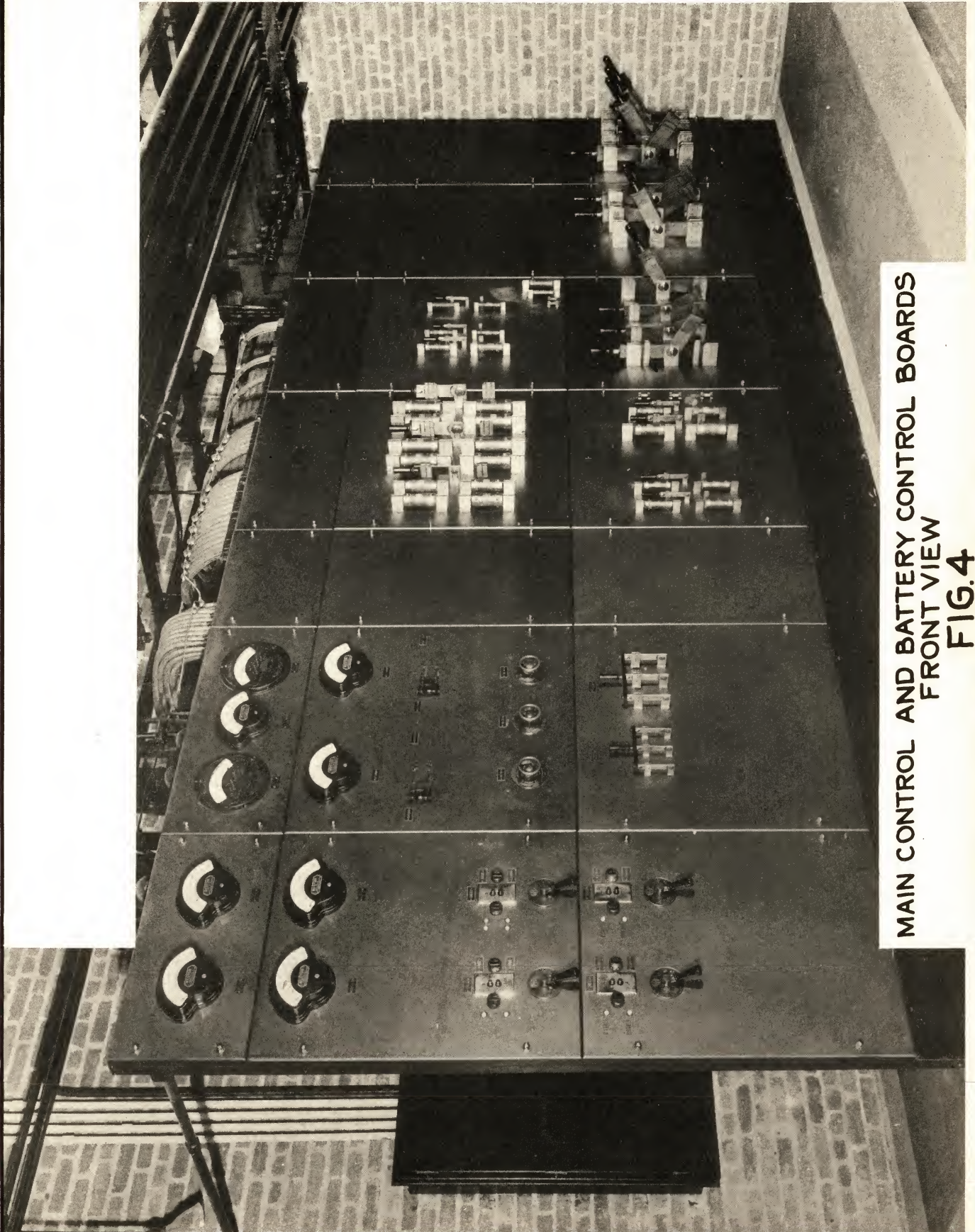

MAIN CONTROL AND BATTERY CONTROL BOARDS
FRONT VIEW
FIG. 4

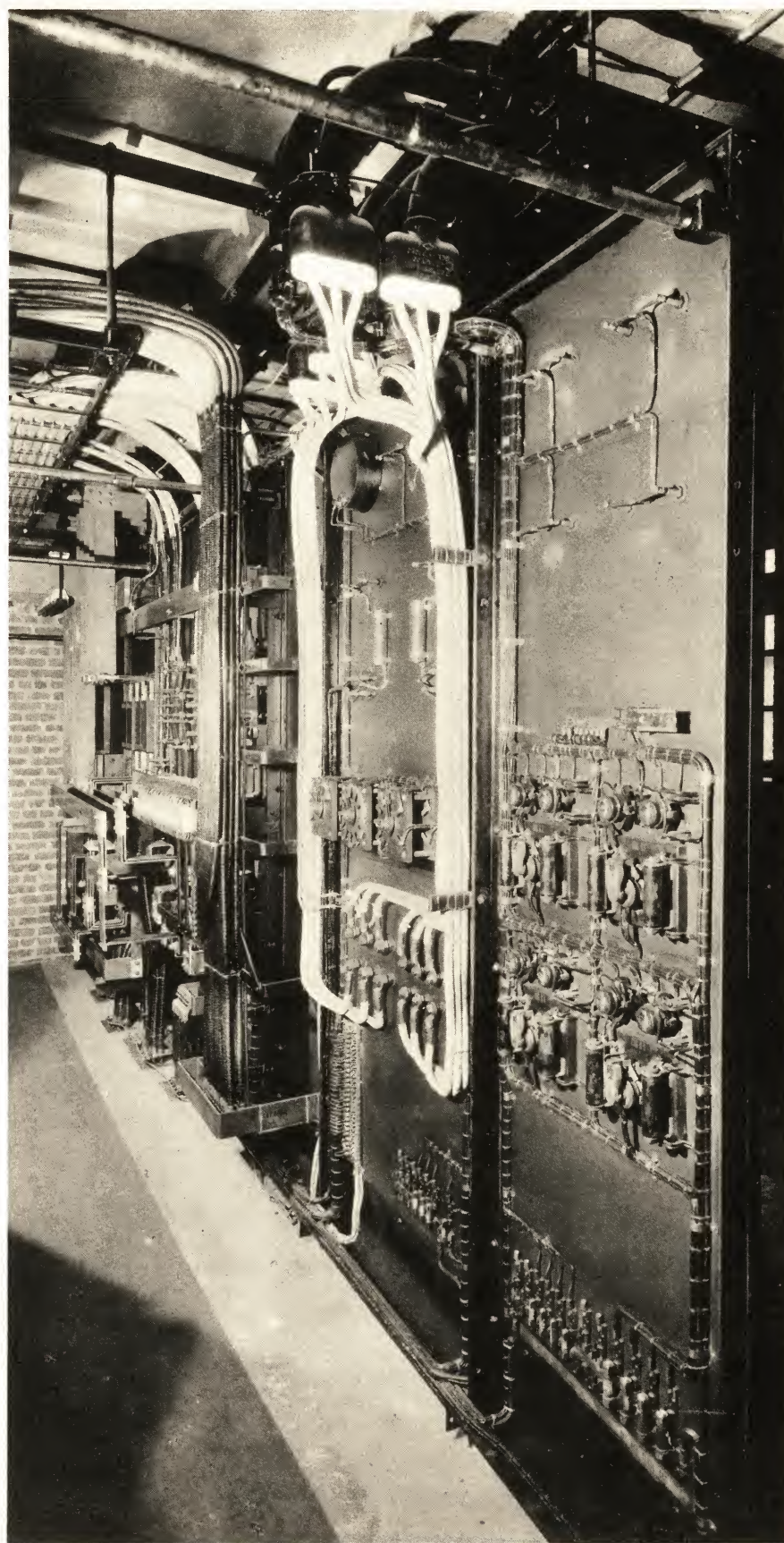

MAIN CONTROL AND BATTERY CONTROL BOARDS
REAR VIEW
FIG. 5

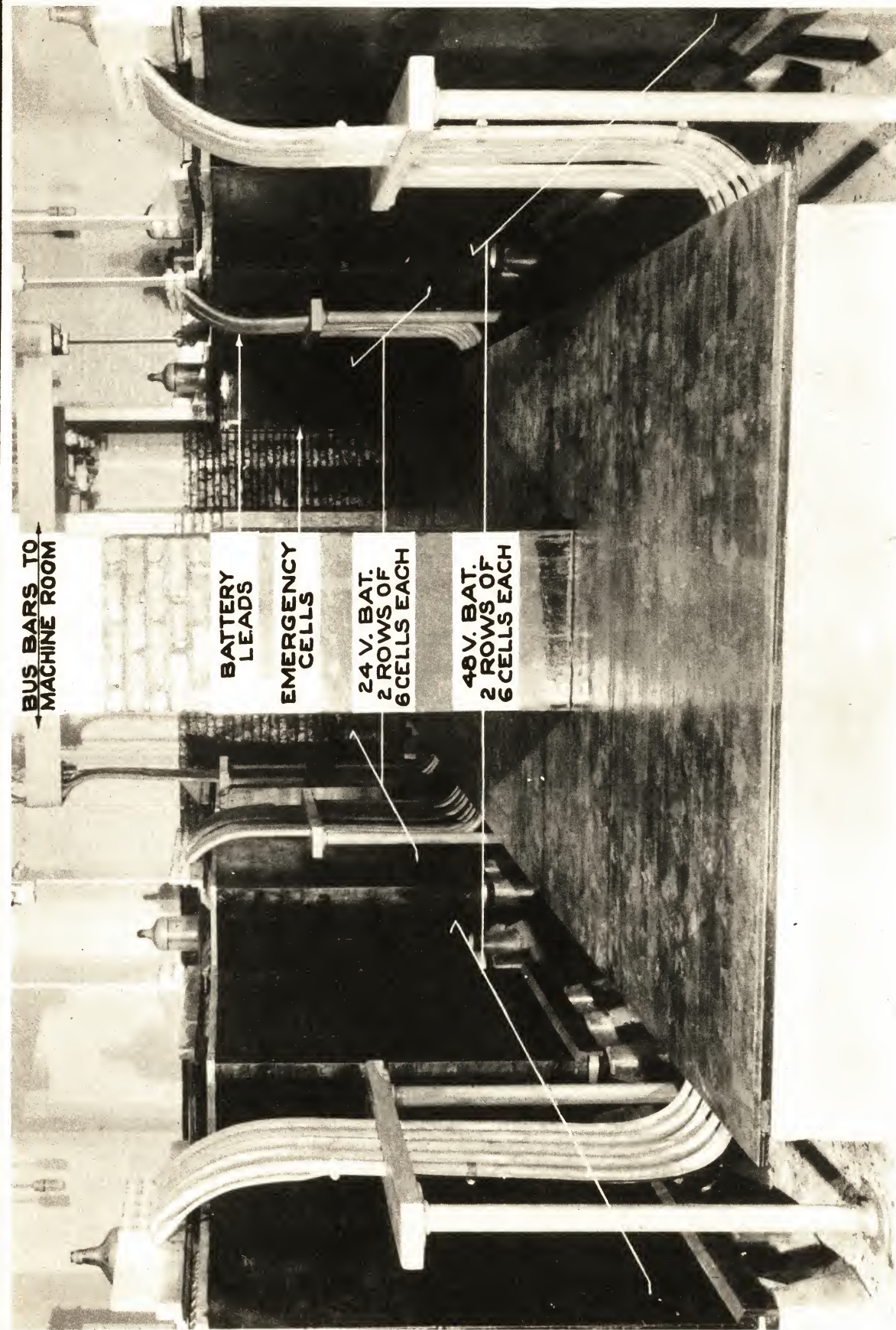

BATTERY ROOM
FIG. 6



BATTERY DISTRIBUTING FUSE PANEL
FIG. 7

24459

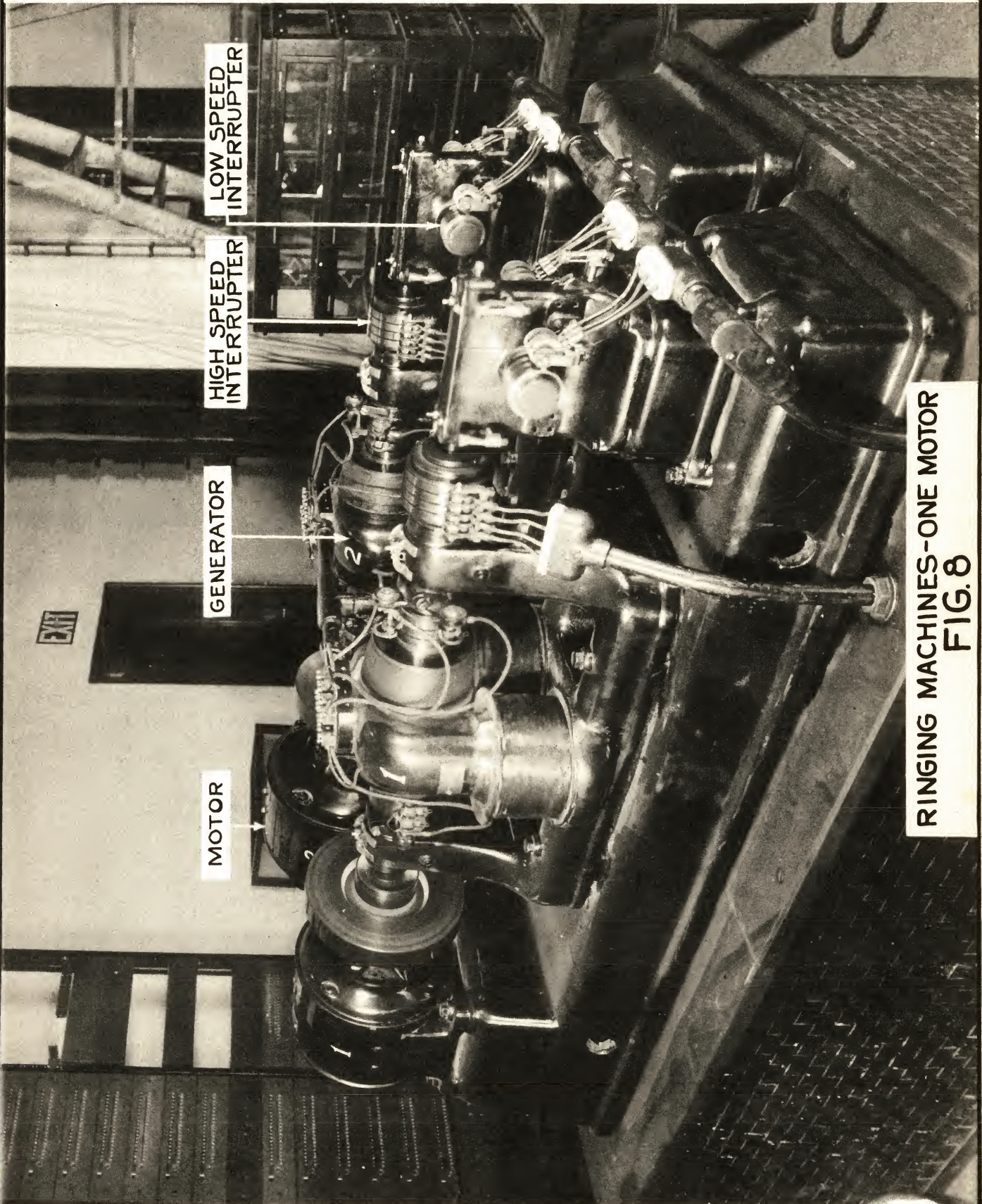

LOW SPEED
INTERRUPTER

HIGH SPEED
INTERRUPTER

GENERATOR

MOTOR

RINGING MACHINES-ONE MOTOR
FIG. 8

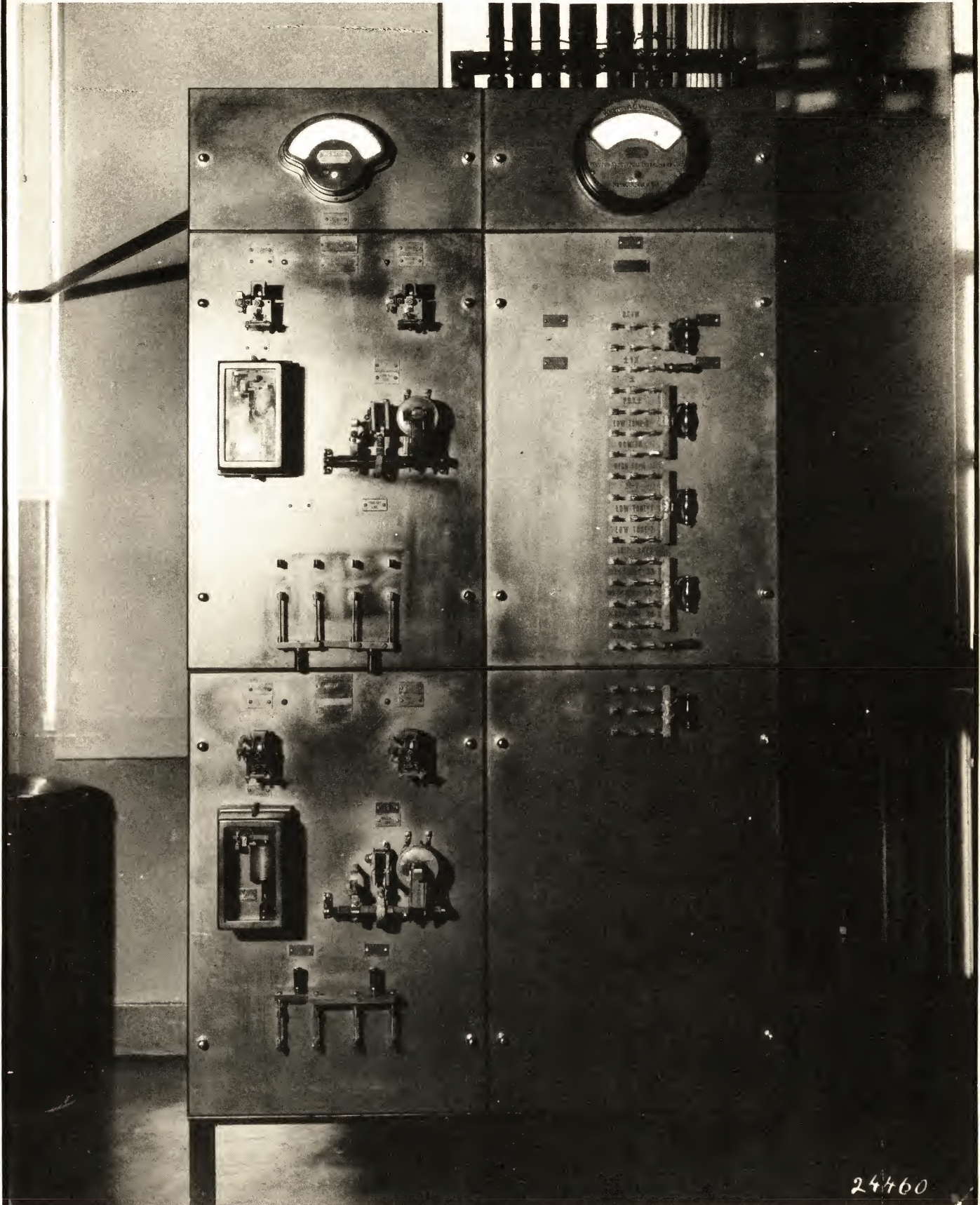

24460

RINGING POWER BOARD
FIG. 9

Errata Sheet

- Fig. 1 - Chap. I Should have trunk lamp shown at "B" Board.
- Fig. 3 - Chap. XI Remove B Commutator at G cam.
- Fig. 1 - Chap. XII Should have line connecting all the "40" groups in "0" banks on all the District Frames.
- Fig. 1 - Chap. XIV Should have cutting 17 added at brush 1, cam B2.

<u>Page</u>	<u>Line</u>	<u>Should Read</u>
58	11	group #4 of bank #2.
62	18	employ split banks on final frames.
70		all reference to (OFL) should be (OF)
72	26	.02 M.F. condenser
91	27	letter or number
95	2	by use of a Panel System "B" Switchboard
95	21	called number to the Panel System "B"
100	1	so as to make it test busy
105	27	the chances of error are less
110	22	a "permanent signal" due to no digits being dialed results, the call is automatically routed
113	9	are recorded in an "A" sender
129	6	(add comma, following senders)
129	16	each unit consisting of 24 drums
147	14	Murray and Varley loop
102-P	19	The "B" switchboard senders do
102-P	21	2' 6-5/8" in width

