

FIG. 1 UNIT C1,2 OR 3

FIG. 2 UNIT A1, A5 OR A9

FIG. 3 UNIT A2, A6 OR A10

FIG. 4 UNIT A3, A7 OR A11

FIG. 5 UNIT A4, A8 OR A12

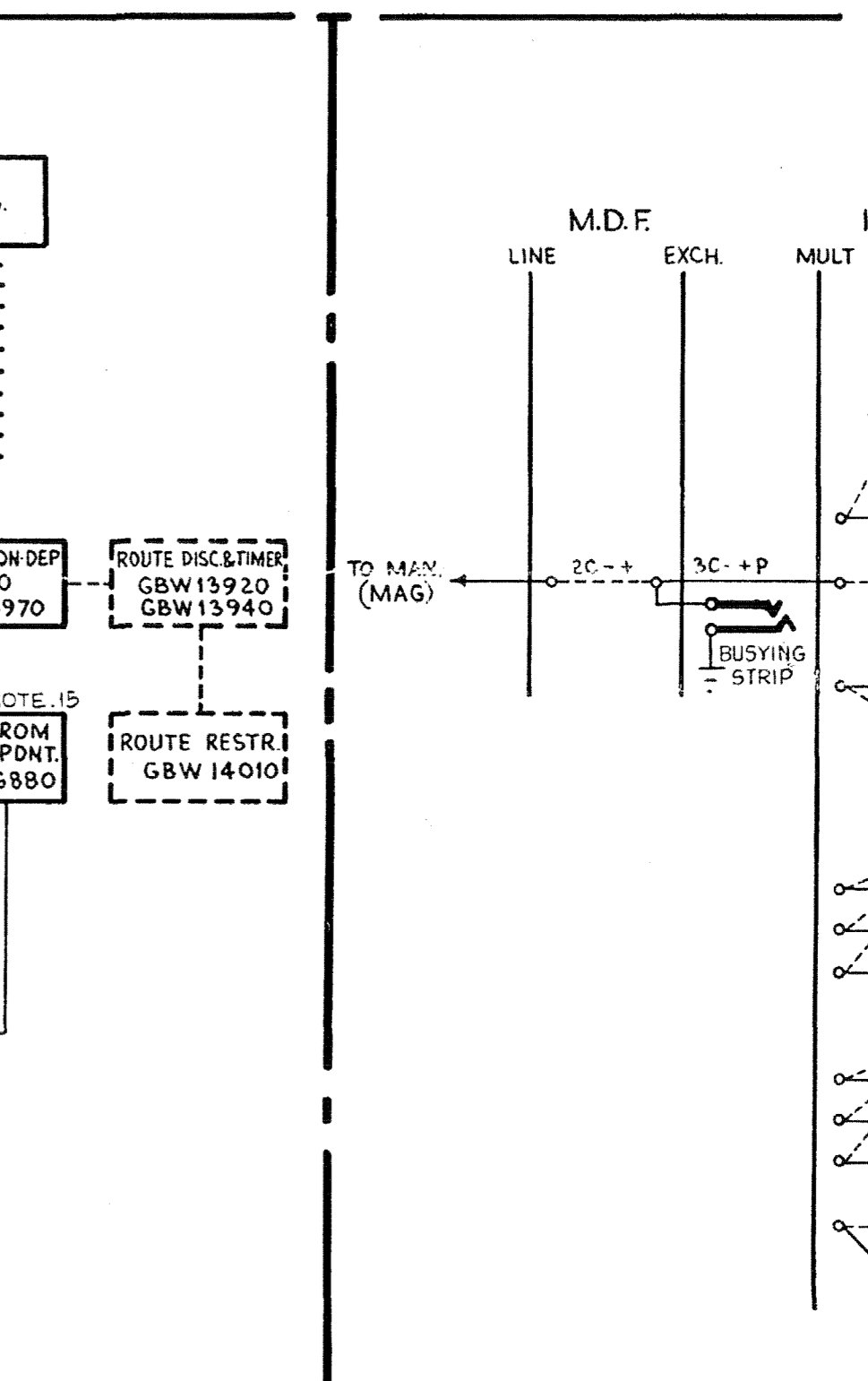
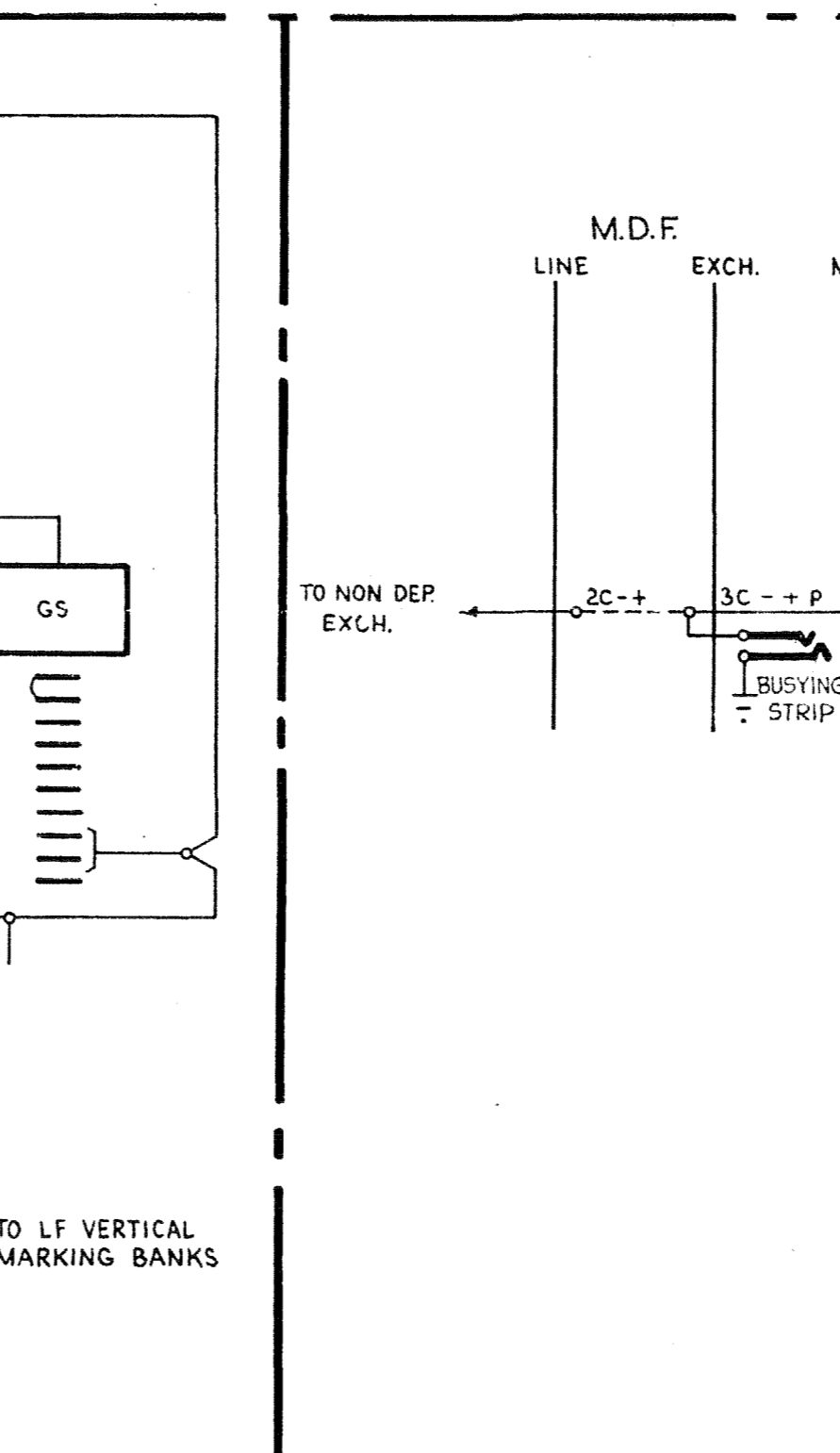
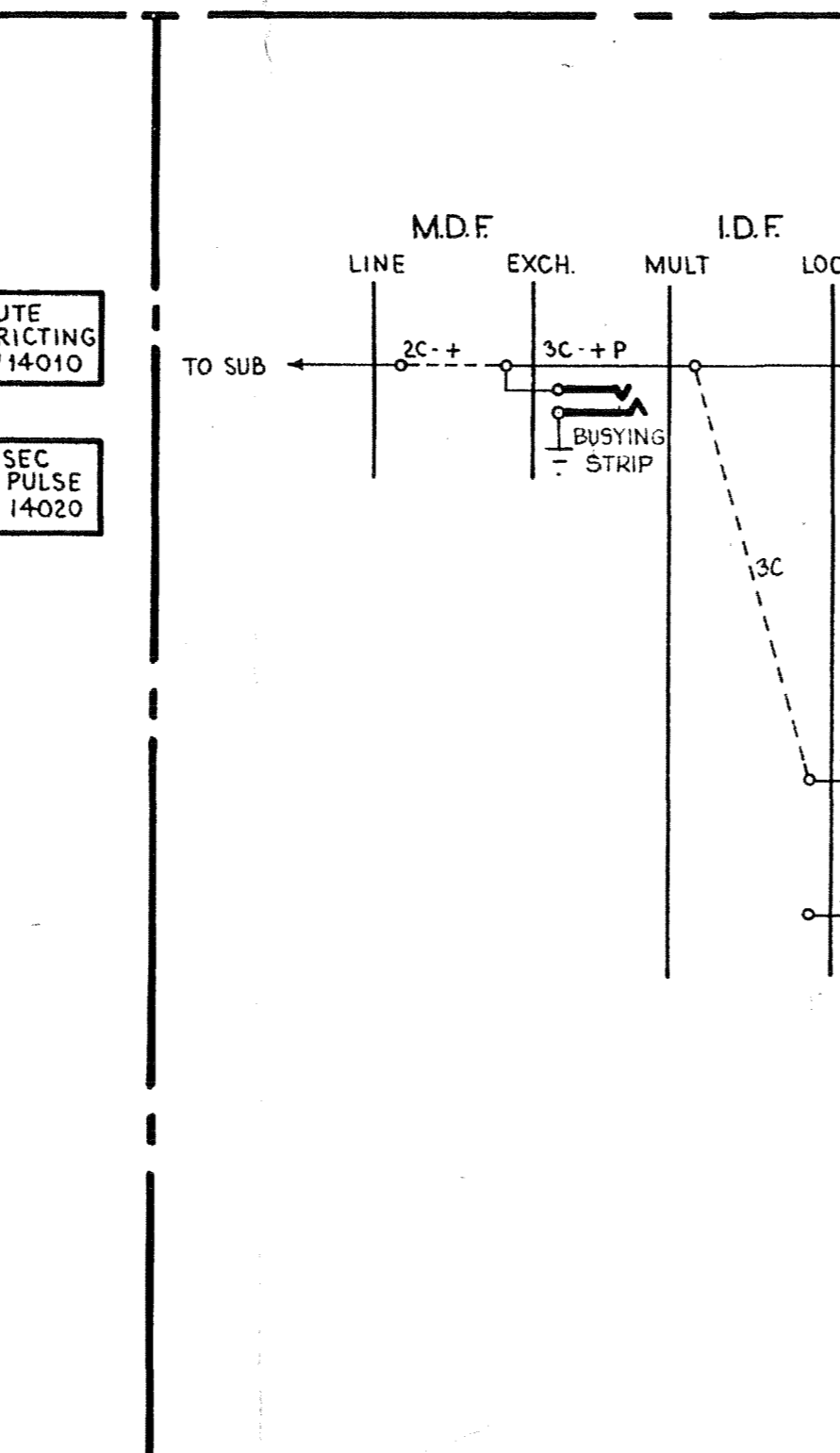
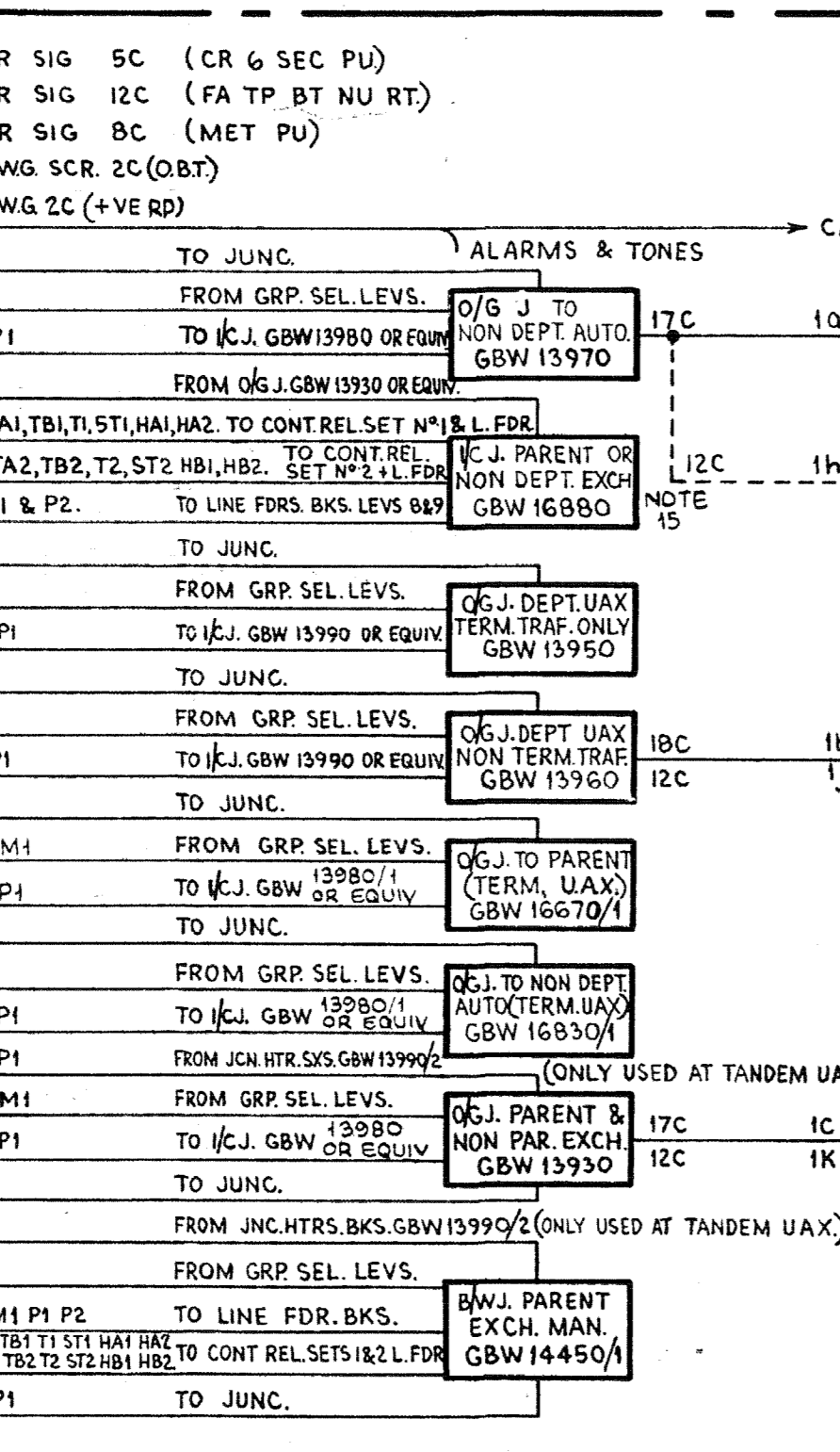
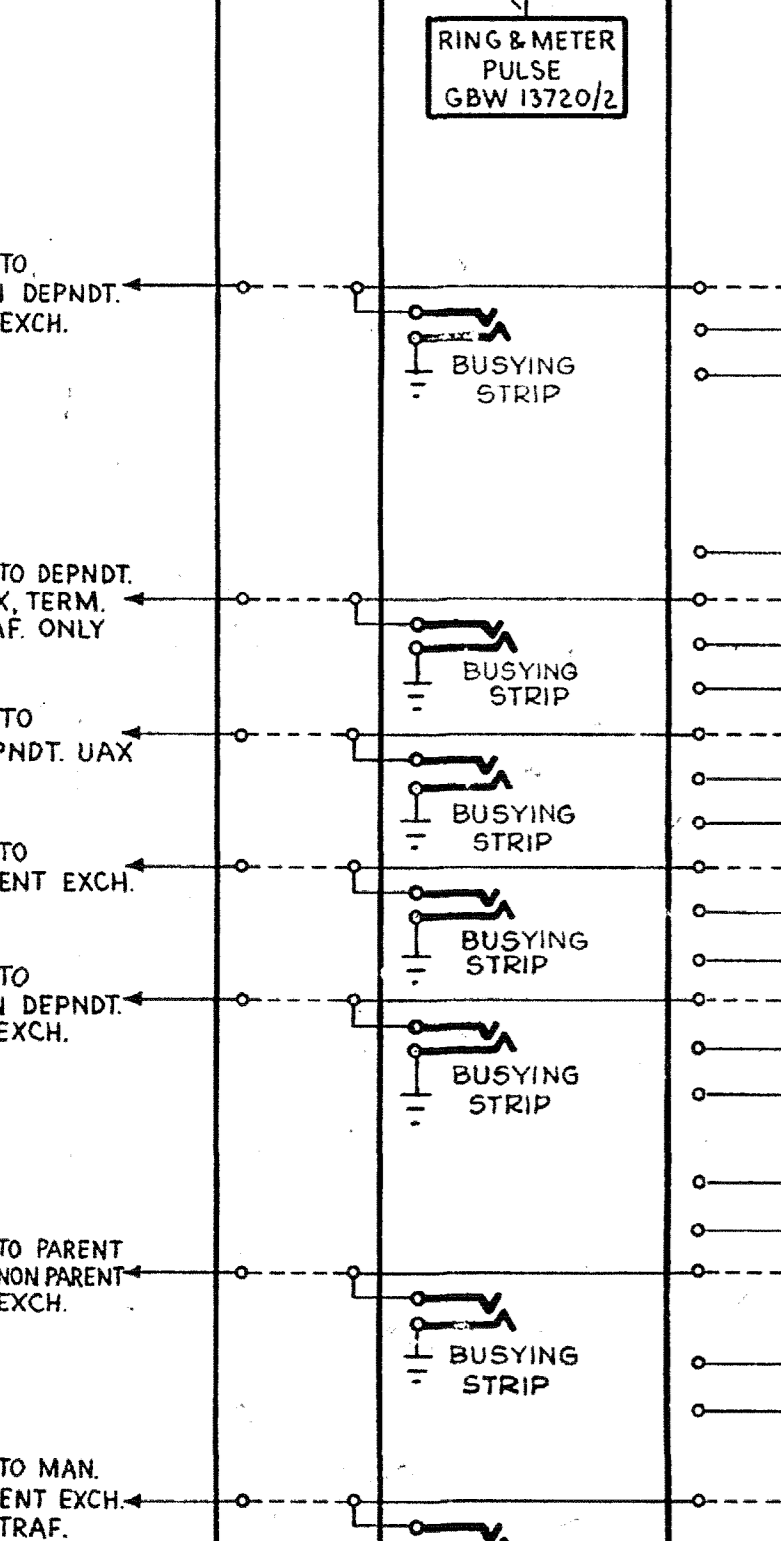
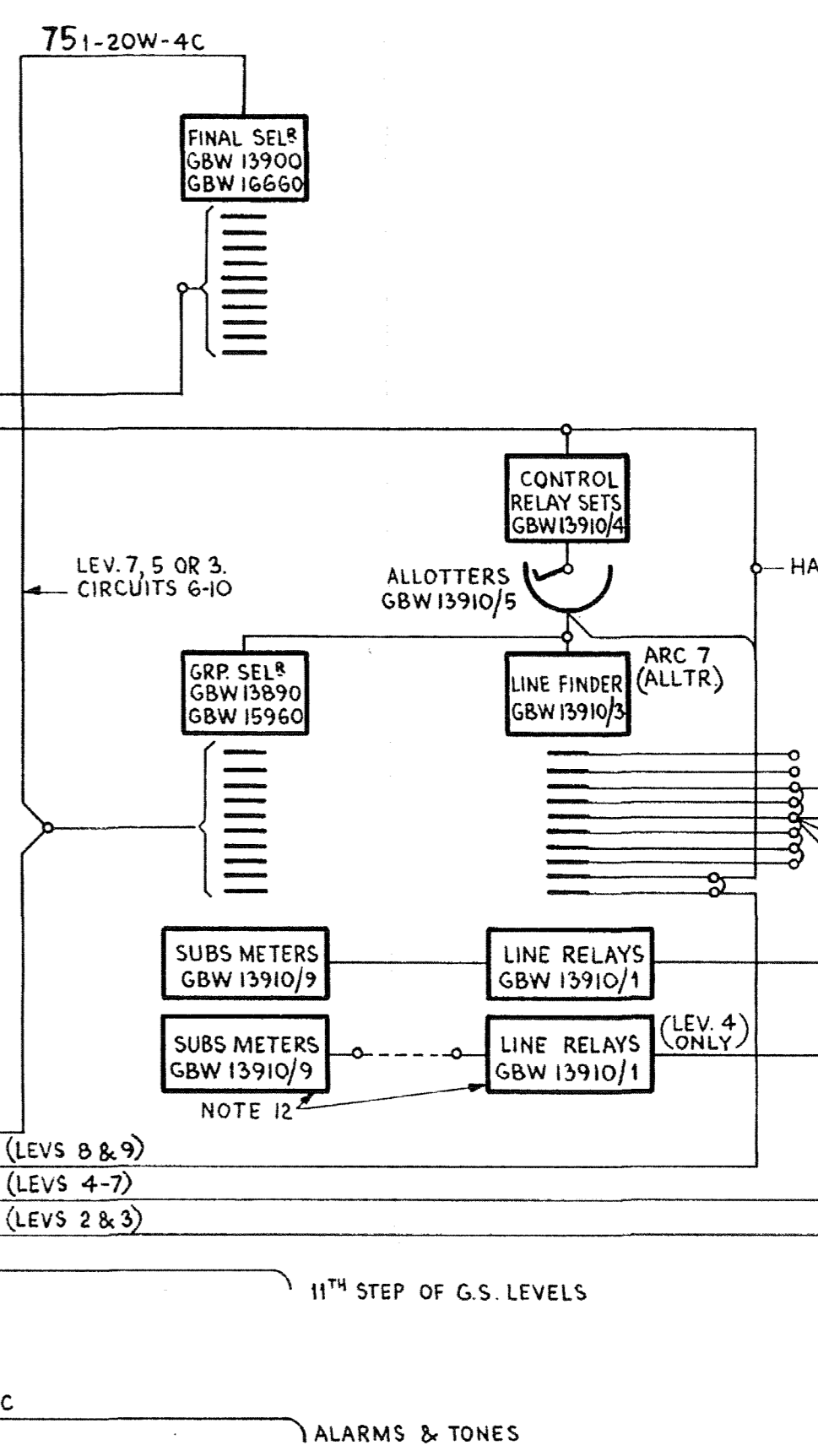
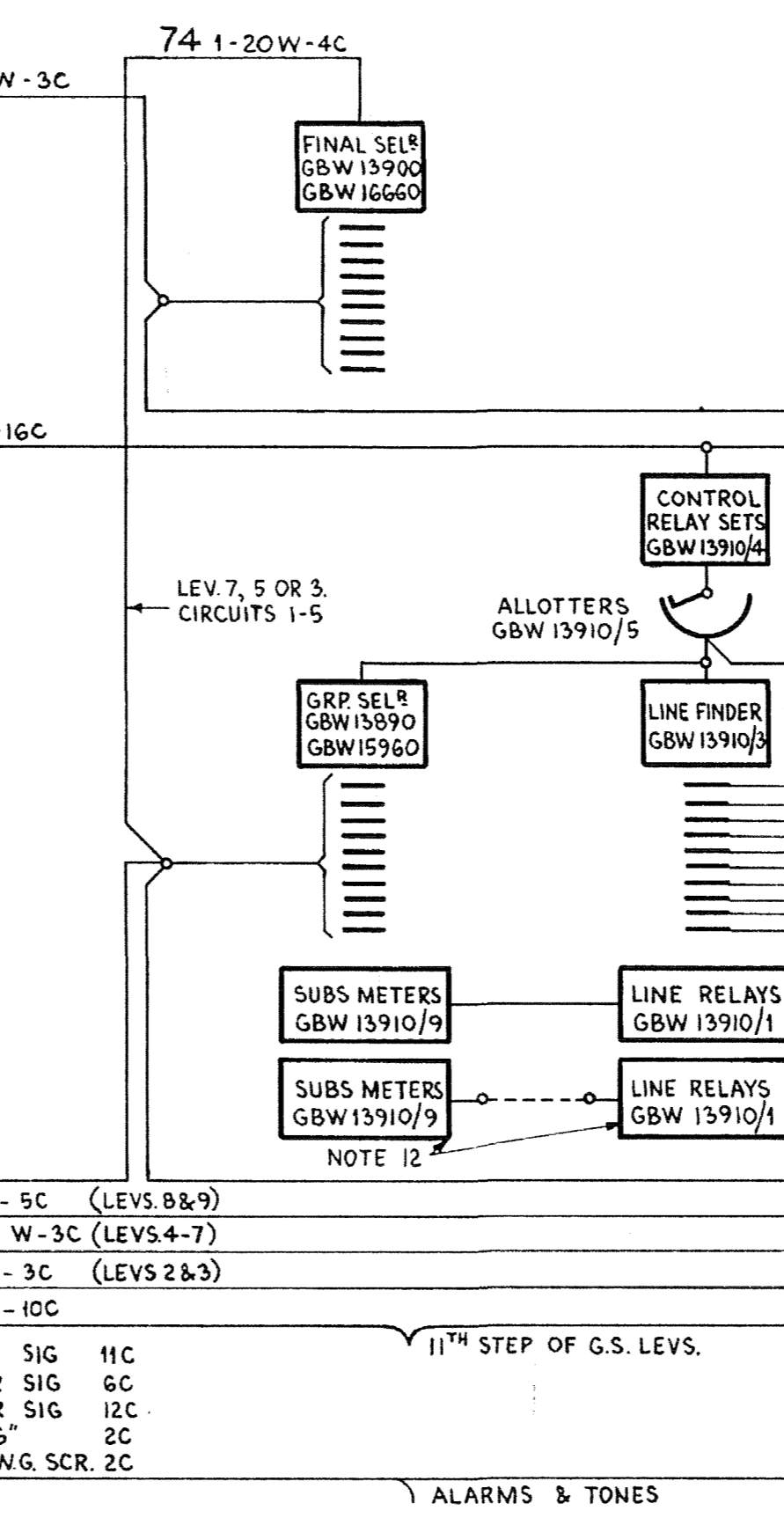
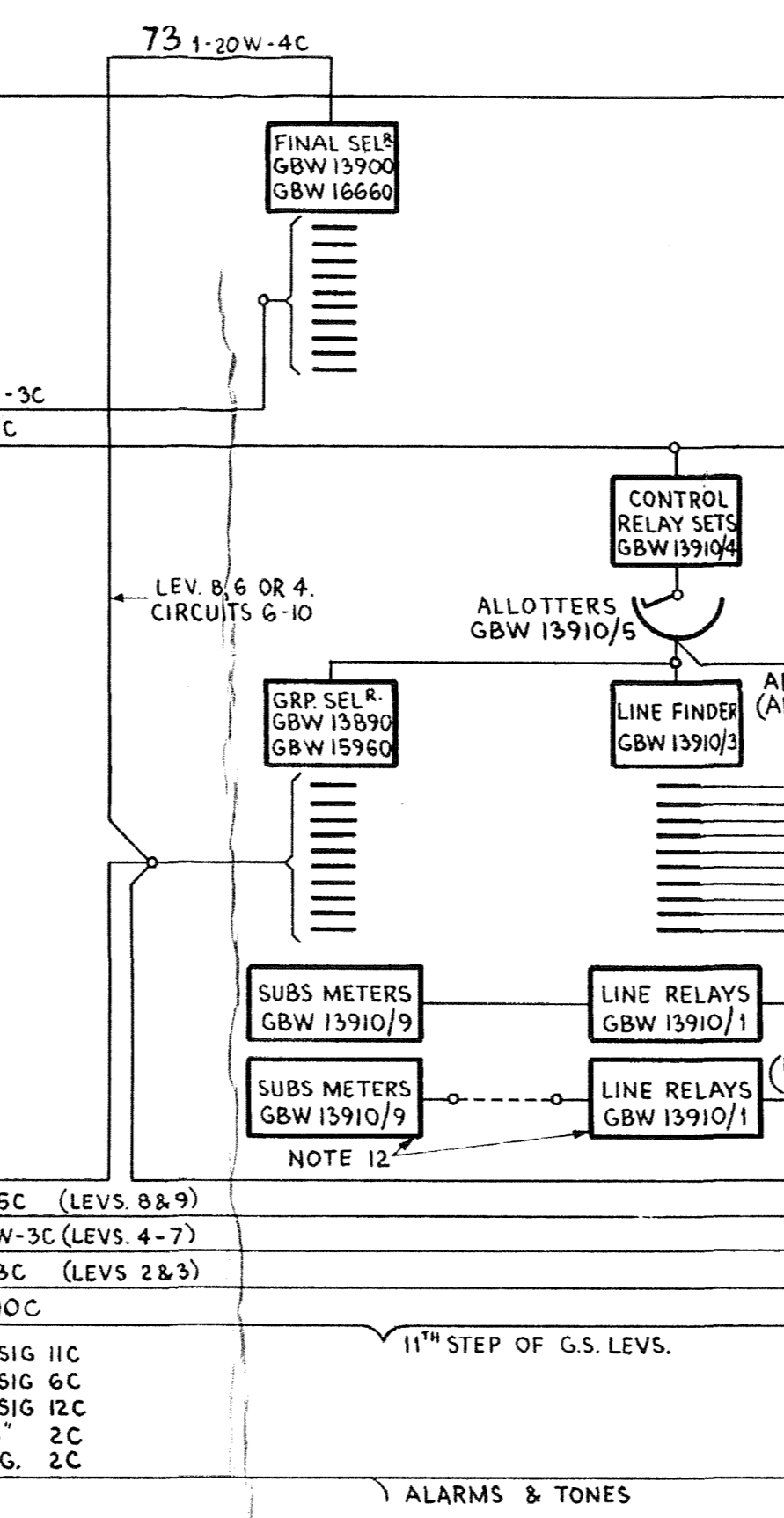
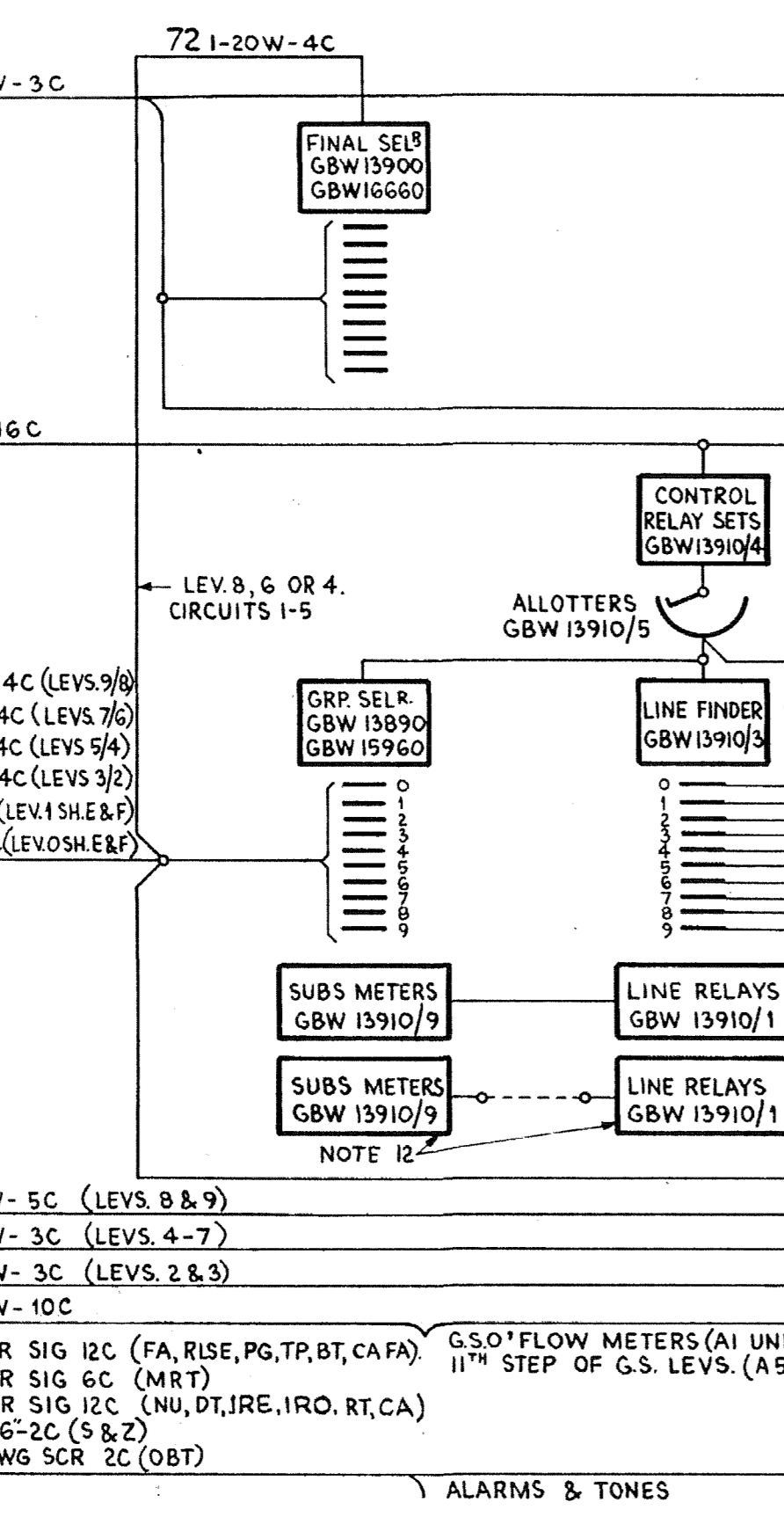
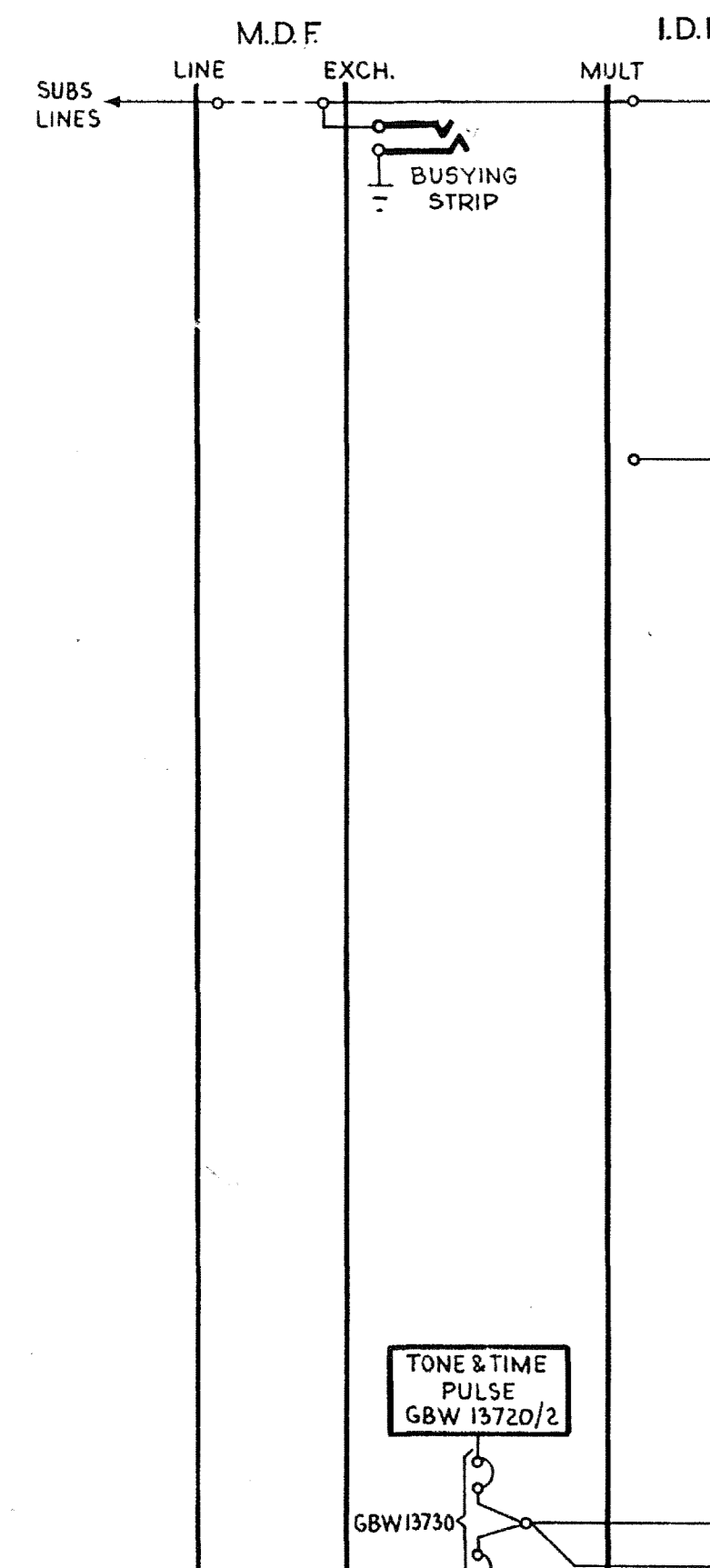

- ALARMS & TONES**
- A 1-3 PR SIG 5C (CR 6 SEC PU)
 - B 1-6 PR SIG 12C (FA TP BT NU RT)
 - C 1-6 PR SIG 8C (MET PU)
 - E 1-20 SWG SCR 2C (OBT)
 - F 1-20 SWG 2C (+VE RD)
- ALARMS & TONES - CABLES TO OTHER 'B' UNITS**
- 3C G - + P TO JUNC.
 - 4C H - + PM FROM GRP SEL SEVS.
 - 3C J - + 1 P1 TO J.C.J. GBW 13980 OR EQUIV.
 - 3C K - + P FROM O.G.J. GBW 13930 OR EQUIV.
 - 1C L - + 1 TAI, TBI, T1, ST1, HAI, HAZ TO CONTROL RELAY SET NO. 1 & L.F.D.R.
 - 1C M - + 2 TA2, TB2, T2, ST2, HBI, HB2, L.F. VERT. MARK. BK. LEV. 9 & HAZ GRP ST. (FIG. 8)
 - 5C N - + P TO JUNC.
 - 4C P - + PM FROM GRP SEL SEVS.
 - 3C Q - + 1 P1 TO J.C.J. GBW 13990 OR EQUIV.
 - 3C R - + P TO JUNC.
 - 3C S - + PM FROM GRP SEL SEVS.
 - 3C T - + 1 P1 TO J.C.J. GBW 13990 OR EQUIV.
 - 3C AB - + P TO JUNC.
 - 5C Z - + PM M1 FROM GRP SEL SEVS.
 - 4C AD - + 1 P1 TO J.C.J. GBW 13980 OR EQUIV.
 - 3C G - + P TO JUNC.
 - 4C H - + PM FROM GRP SEL SEVS.
 - 3C J - + 1 P1 TO J.C.J. GBW 13980 OR EQUIV.
 - 5C Y - + 1 + 1 P1 FROM JCN. HTR. BKS. GBW 13990 (ONLY USED AT TANDEM UAX)
 - 3C Z - + PM M1 FROM GRP SEL SEVS.
 - 3C AA - + 1 P1 TO J.C.J. GBW 13980 OR EQUIV.
 - 3C AB - + P TO JUNC.
 - 3C AC - + P FROM JCN. HTR. BKS. GBW 13990 (ONLY USED AT TANDEM UAX)
 - 4C AD - + PM FROM GRP SEL SEVS.
 - 5C AE - + 1 + 1 P1 P2 TO LINE FDR. BKS.
 - 1C AF - + 1 TAI, TBI, T1, ST1, HAI, HAZ TO CONTROL RELAY SETS NO. 1 & L.F.D.R.
 - 3C AG - + 1 P1 TO JUNC.

FIG. 2 - B UNITS CABLING NOTES 1 & 4

FIG. 3 LEVELS 7 & 8

FIG. 4 LEVELS 2 & 4 NOTE 3

FIG. 5 LEVEL 3 NOTES 1 & 3

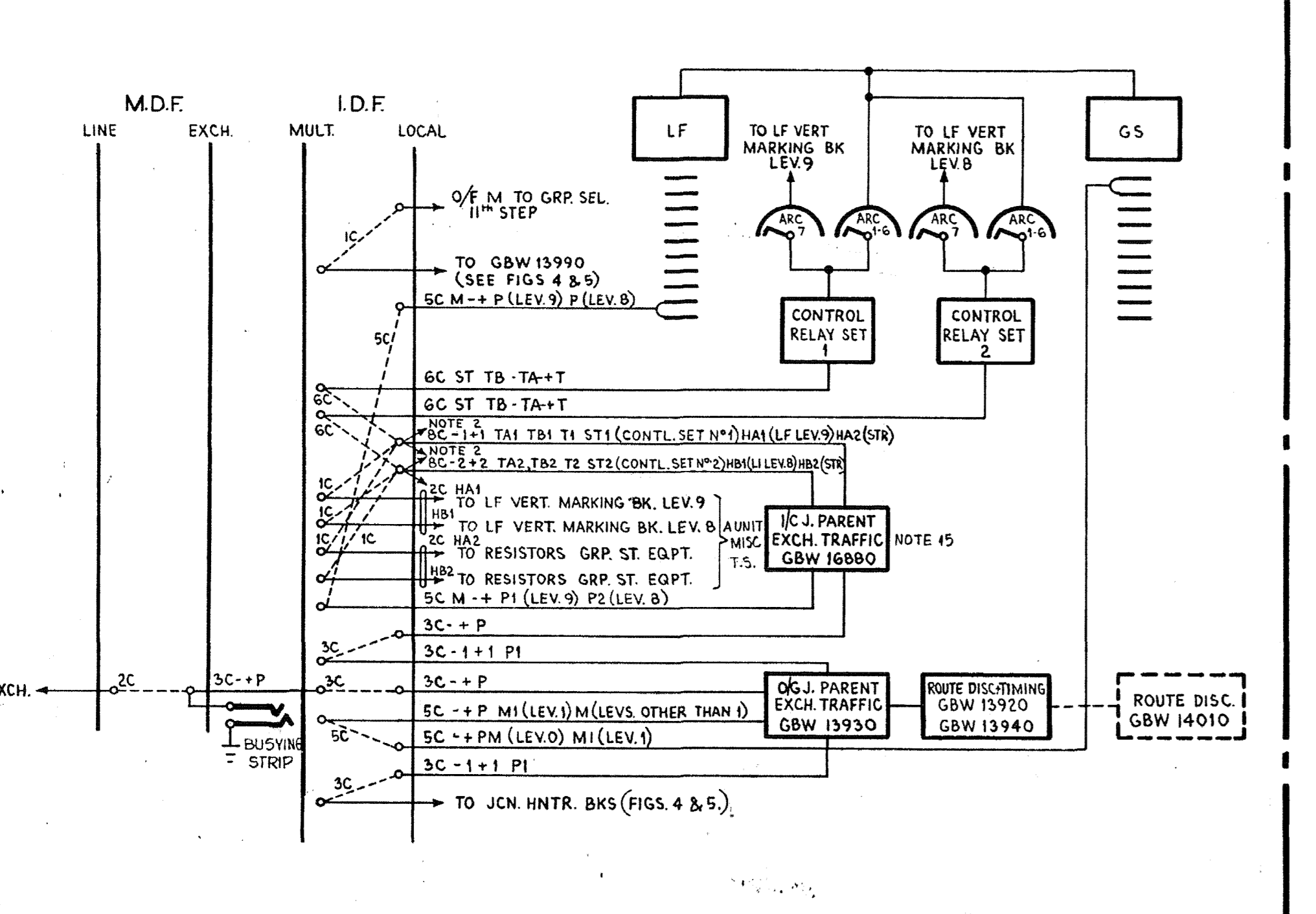

FIG. 6 LEVELS 0 & 1.

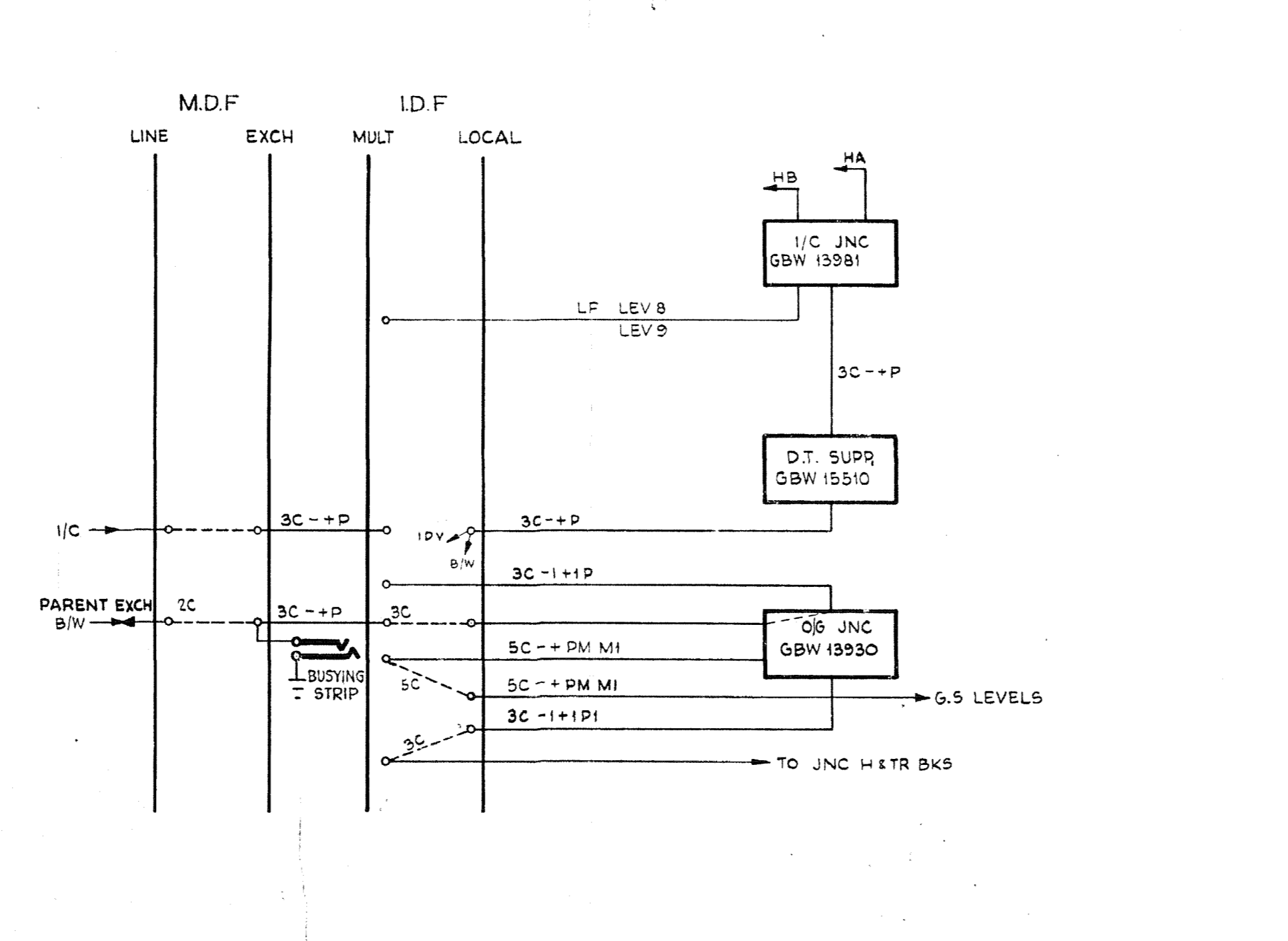

FIG. 6A D.T. SUPPRESSOR CABLING

- NOTES:-**
- 14 FOR TWO PARTY WORKING ONLY ONE SUBS LINE CCT REQUIRED
 - 15 SHOULD ALTERNATIVE GBW 13981 BE USED
 - 16 LEVEL 2 AND 3 - + P BANK MULTIPLE WIRES ARE COMMONED AND SELECTION OF THE REQUIRED LEVEL IS ACHIEVED BY STRAPPING THE APPROPRIATE CIRCUIT ON THE "MULTI-PARTY C.C.B." A UNIT T.S.
 1. FOR TANDEM UAX CABLING, JUMPERING & TRUNKING ARRANGEMENTS SEE FIGURES 24-28.
 2. COMMONED TO OTHER STRIP-MOUNTED SETS AS REQUIRED.
 3. GROUP SELECTOR LEVEL ALLOCATIONS ARE TYPICAL ONLY.
 4. FOR CABLING & JUMPERING OF UAX NZ 13 R AND M UNITS AND 5 PARTY LINE SM RELAY SETS, SEE SHEET 2.
 5. NO CONNECTION IS REQUIRED FROM O/G JUNCTION RELAY SET GBW 16671 OR EQUIVALENT TO 1/C JUNCTION RELAY SET GBW 16880 OR EQUIVALENT WHERE NZ 55 AC N° 3 IS EMPLOYED.
 6. DELETED
 7. THE REVERTIVE CALL RELAY SET GBW 13770 IF USED ONLY FOR 2 PARTY SHARED SERVICE DOES NOT REQUIRE CODE RINGS GBW 13760/2.
 8. AS A REMOTE R OR M UNIT AND JUNCTIONS USING AC 3 SIGNALLING HAVE BUILT-IN DIAL TONE SUPPRESSION, GBW 13981 MAY BE USED IF DESIRED.
 9. FOR NZ 55 AC N° 3 TRUNKING OF UAX NZ 13, AMX OR UAX NZ 13 TO DEPENDENT SEE SHEET 3.
 10. NO CONNECTION IS REQUIRED TO AN 1/C JUNCTION CIRCUIT ON UNIDIRECTIONAL O/G JUNCTIONS.
 11. AT NON-METERING UAX'S USE NZ P.O. 26174 AND DELETE CONNECTIONS SHOWN X-X-X. AT METERING UAX'S USE GBW 13970 AND DELETE CONNECTIONS SHOWN -I-I-I-.
 12. ADDITIONAL LINE RELAYS AND METERS WIRED BY INSTALLER AS REQUIRED
 13. WHERE A CIRCUIT N° IS SHOWN THIS, GBW 13970/4 THE N° FOLLOWING THE OBLIQUE STROKE INDICATES THE RELEVANT FIGURE OF THE DRAWING.
- NZ. NOTES**
- A: FIG 10A SHOWS THE TRUNKING AND CABLING OF A REMOTE M UNIT. I.E. AN 'R' UNIT MODIFIED TO GIVE M SERVICE.

ISS DATE	CHKD	APPD.	DEL	ORDN	CHANGE	NEW ZEALAND POST OFFICE ENGINEER-IN-CHIEF, WELLINGTON.
1977	K.G.	K.G.		13930	PREVIOUSLY T.E. 6/20	

TYPICAL CABLING, JUMPERING & TRUNKING ARRANGEMENTS UAX. NZ 13

COY. N°	SIZE	SHEET
ORIGIN	L	OF
REFERENCE GBW 15780	4	4/231
DRAWN/TEL. EQPT/TRACE	A.F.G.	

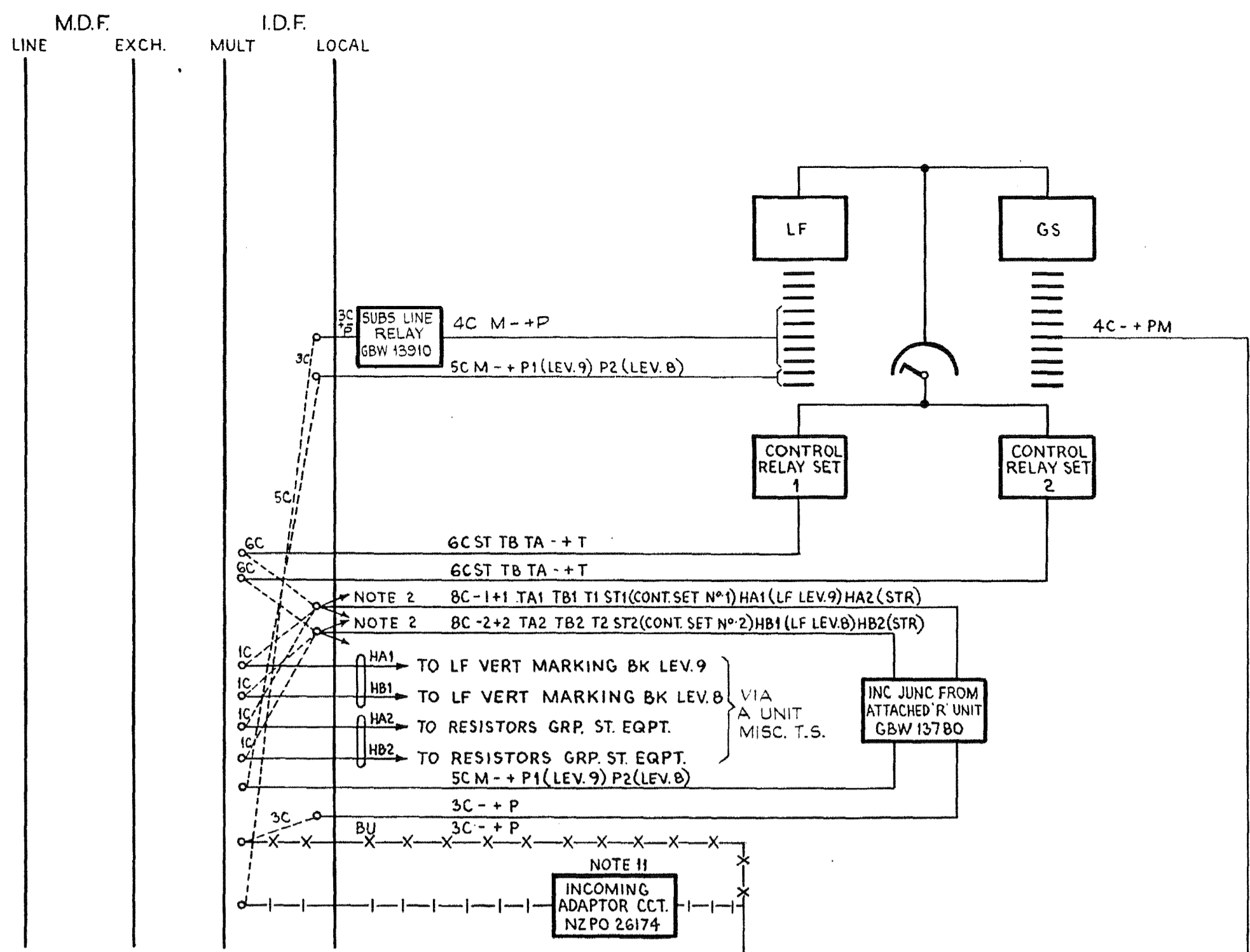

FIG. 7 PART OF 'A', 'B' & 'C' UNITS

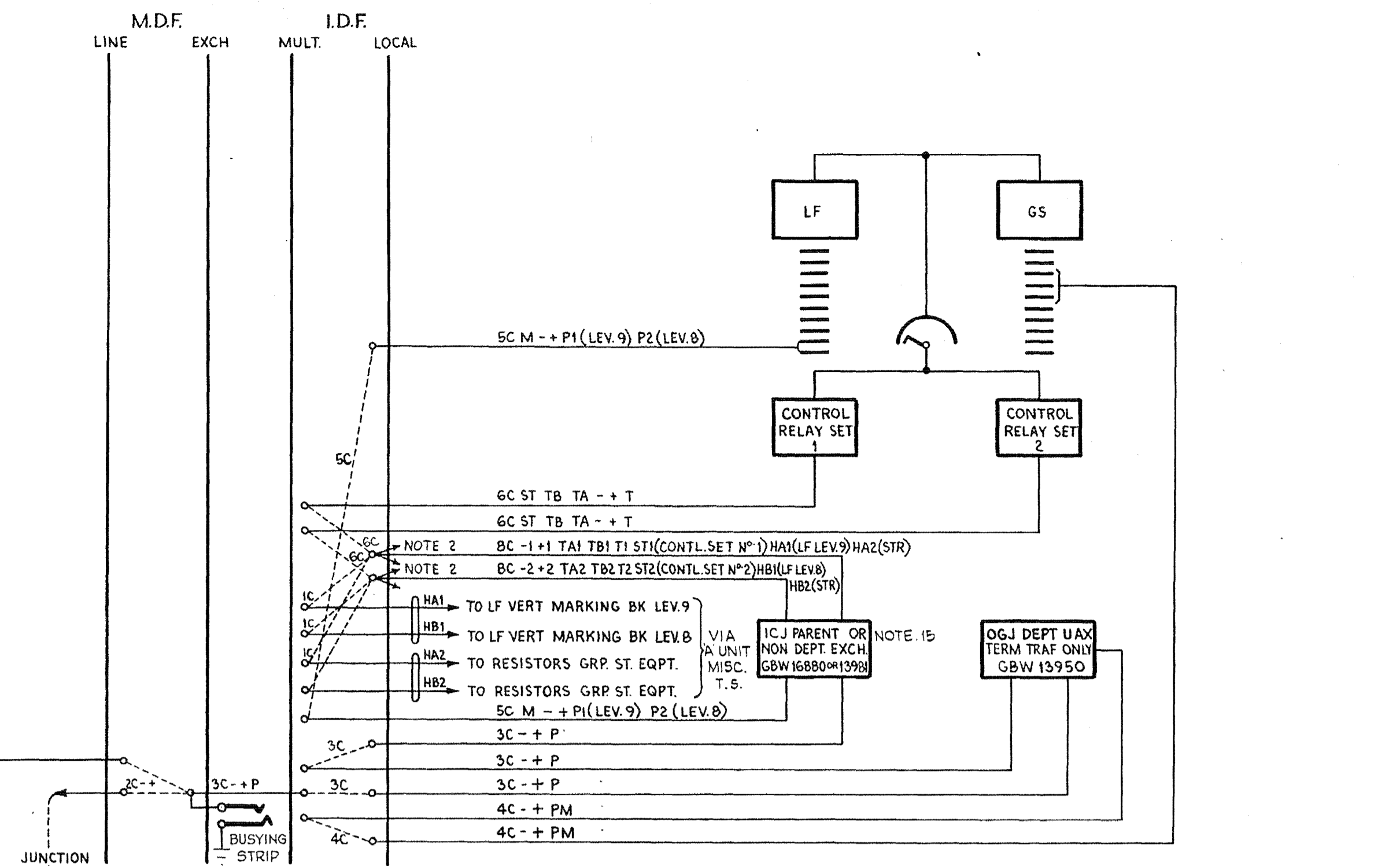

FIG. 9 PART OF 'A', 'B' & 'C' UNITS

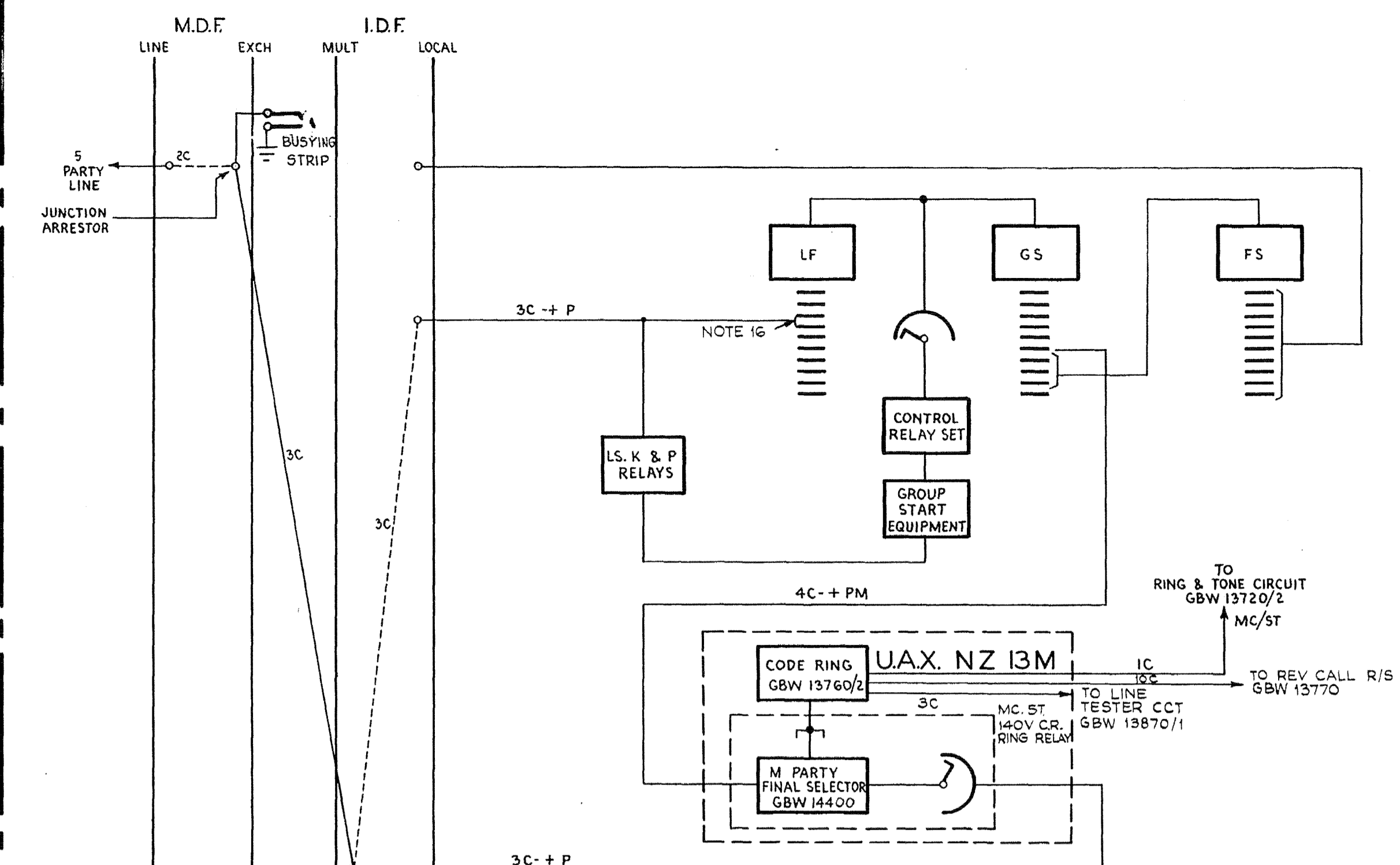

FIG. 11 'M' UNIT (& PART OF 'A', 'B' & 'C' UNITS)

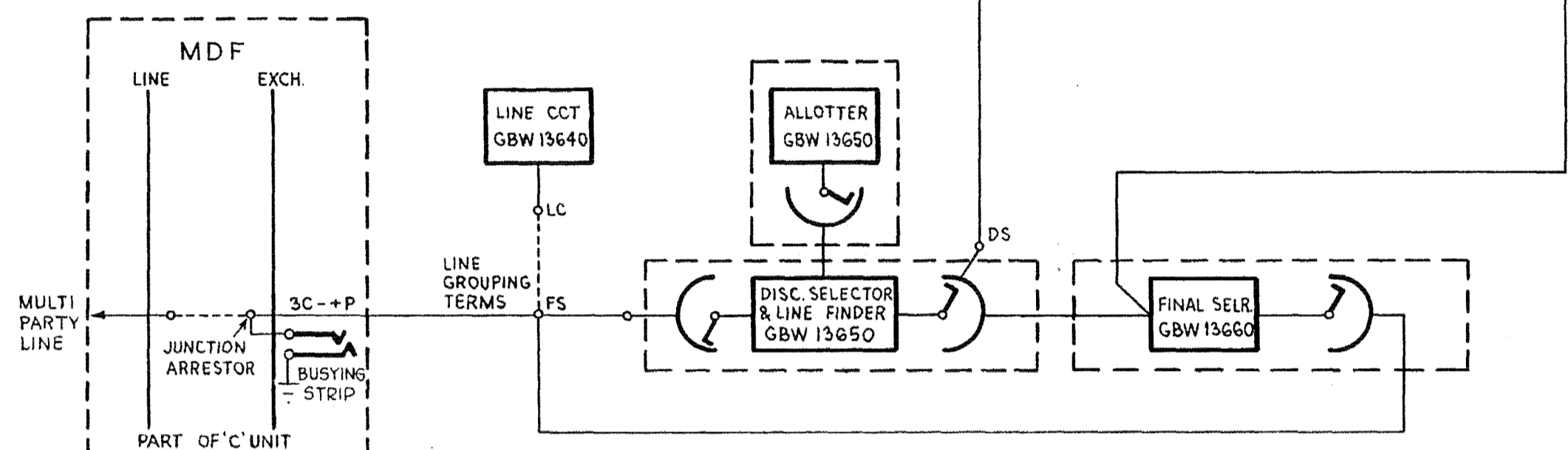

FIG. 8 'R' UNIT (ATTACHED)

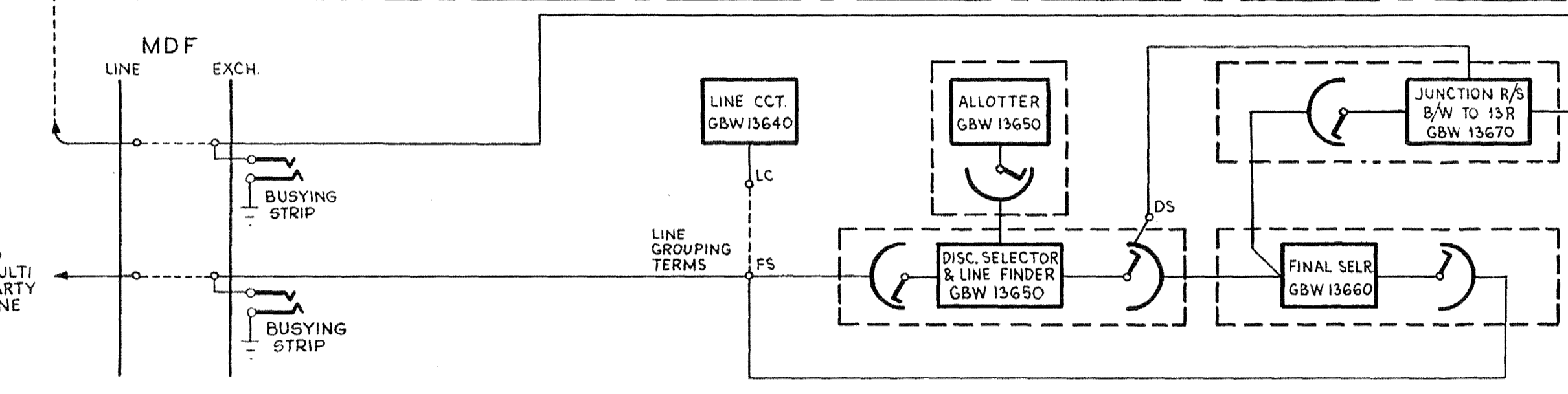

FIG. 10 'R' UNIT (REMOTE)

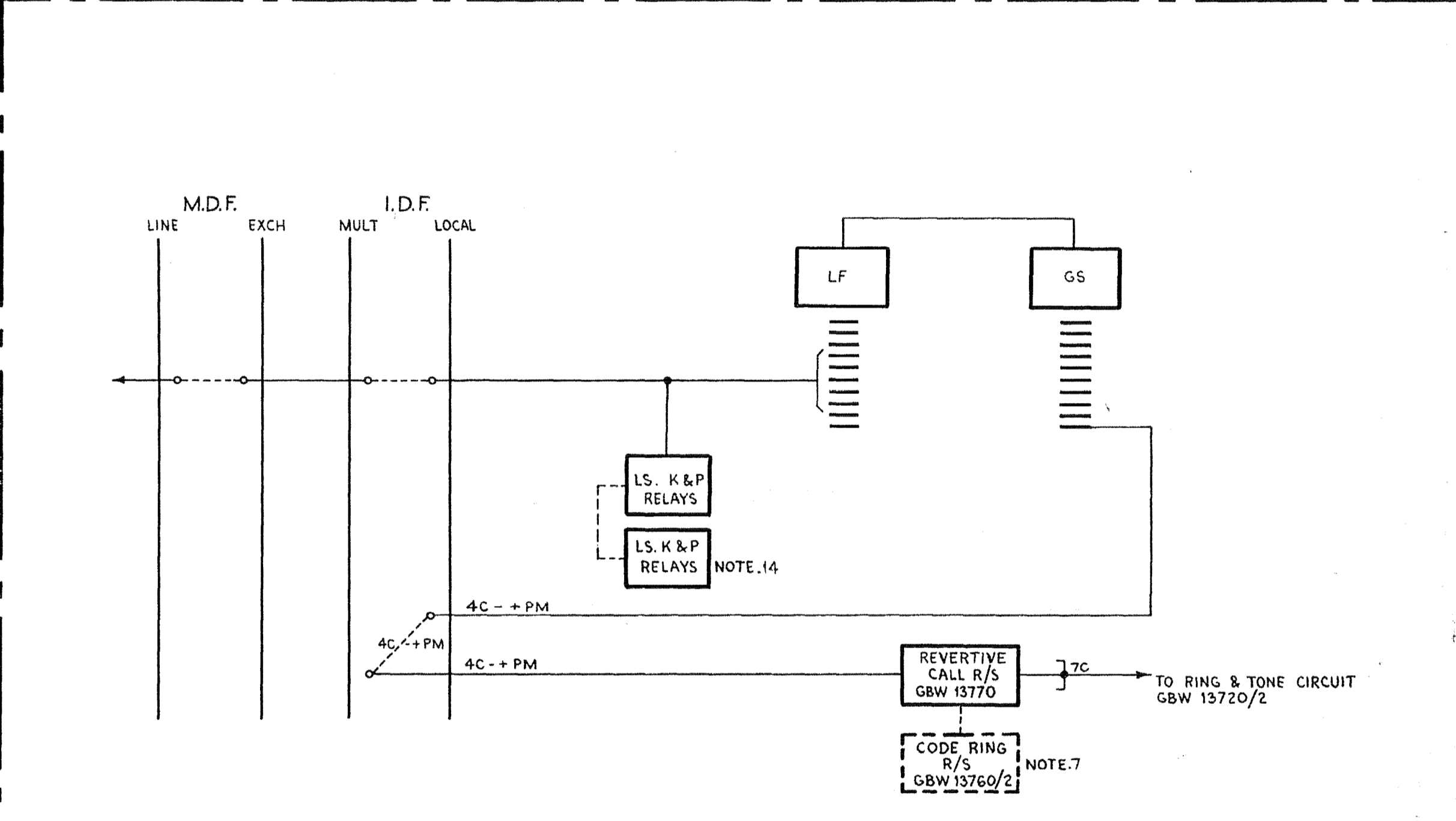

FIG. 14 2-PARTY AND SHARED SERVICE WITH REVERTIVE CALLING EQUIPT.

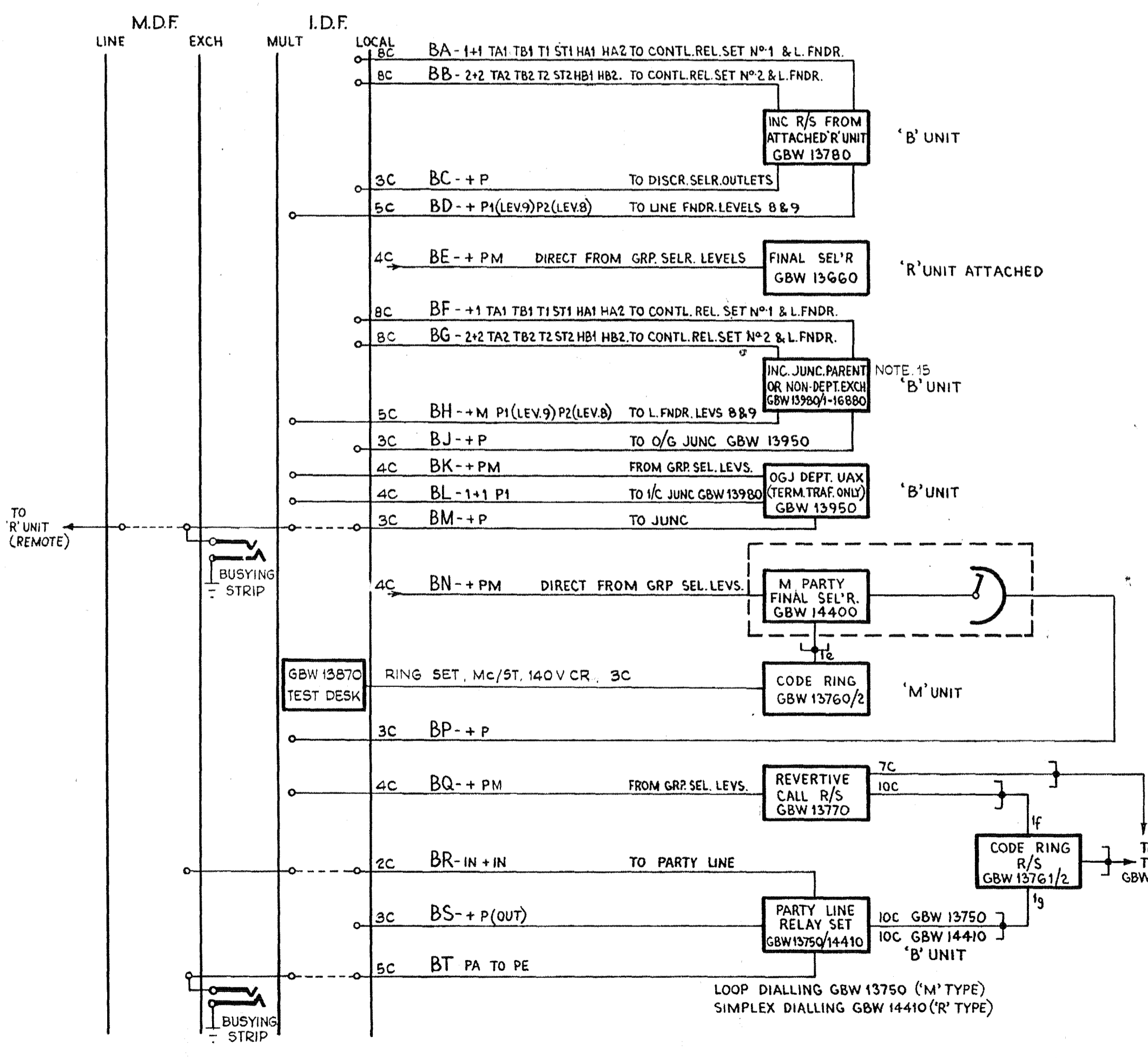

FIG. 12 'B', 'R' & 'M' TO 'C' UNIT CABLING

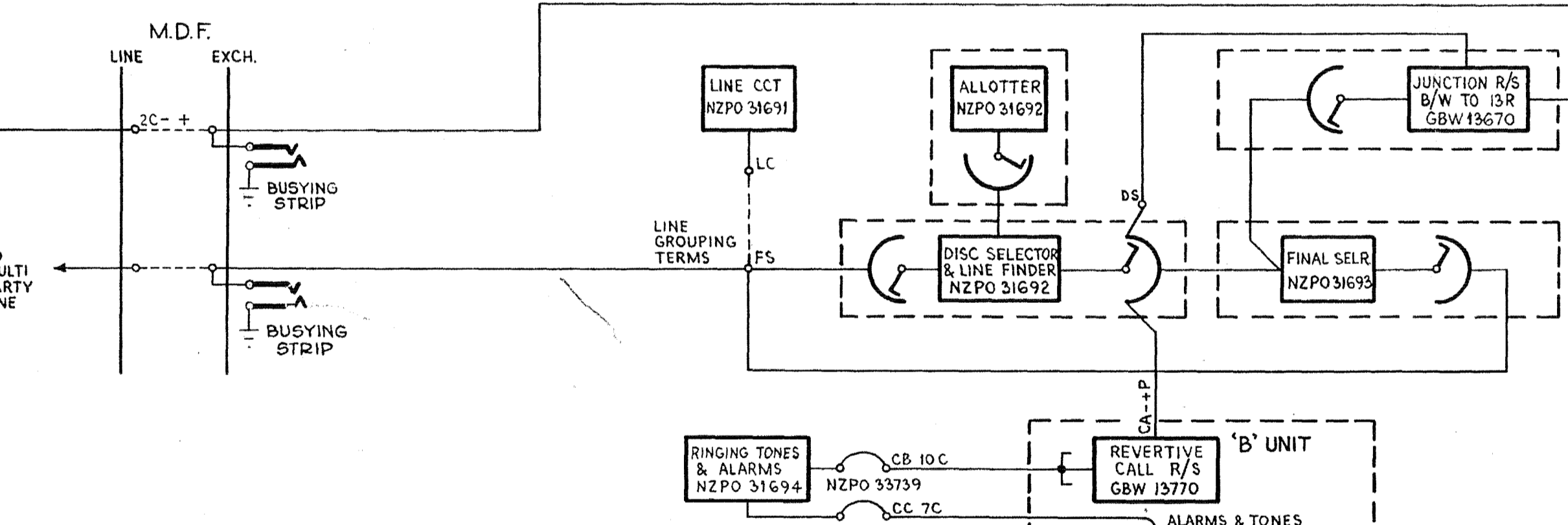

FIG. 10A REMOTE 'M' UNIT (NZ NOTE A)

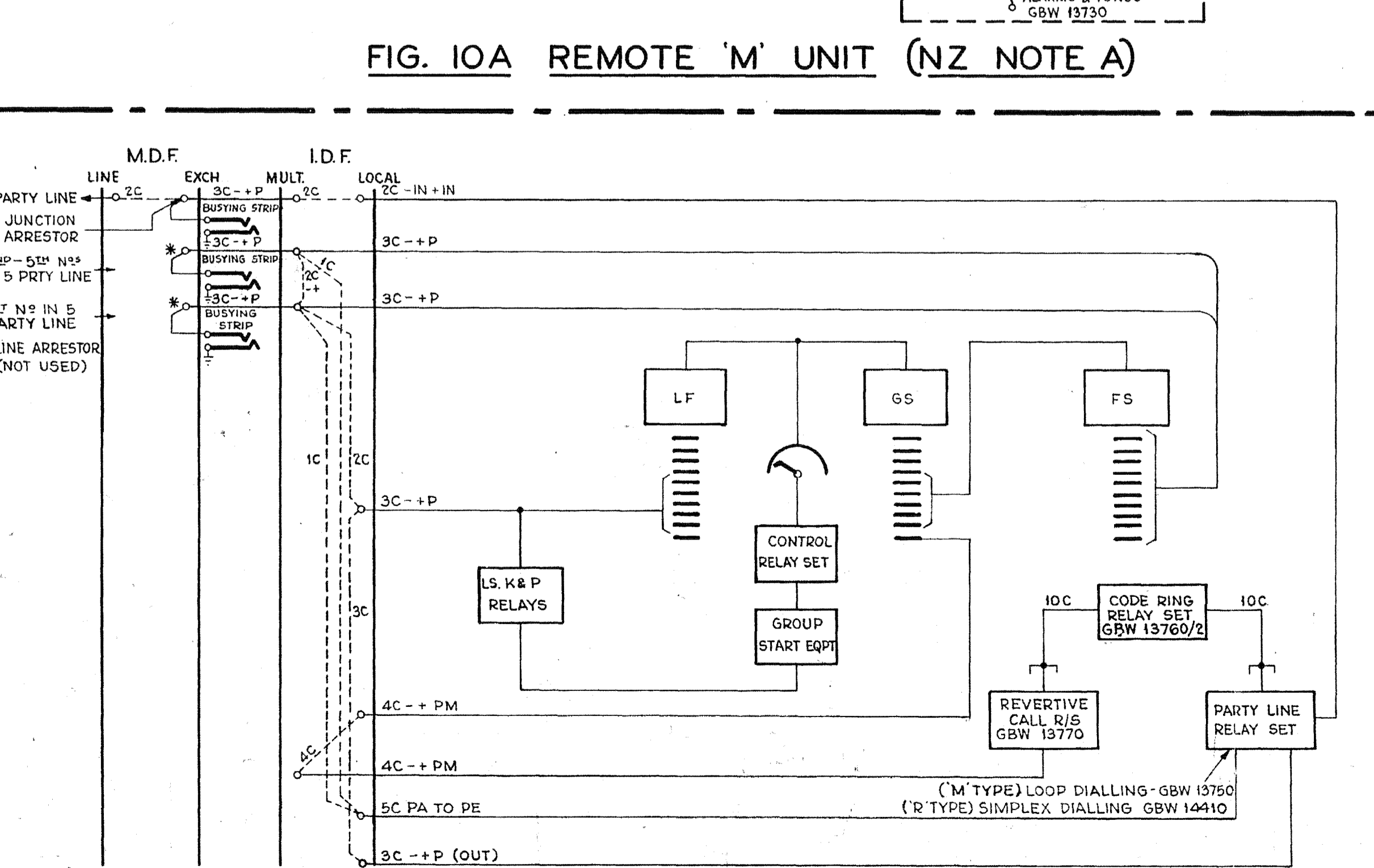

FIG. 13 5 PARTY LINES WITH LOOP & SIMPLEX DIALLING & REVERTIVE CALLING EQUIPMENT

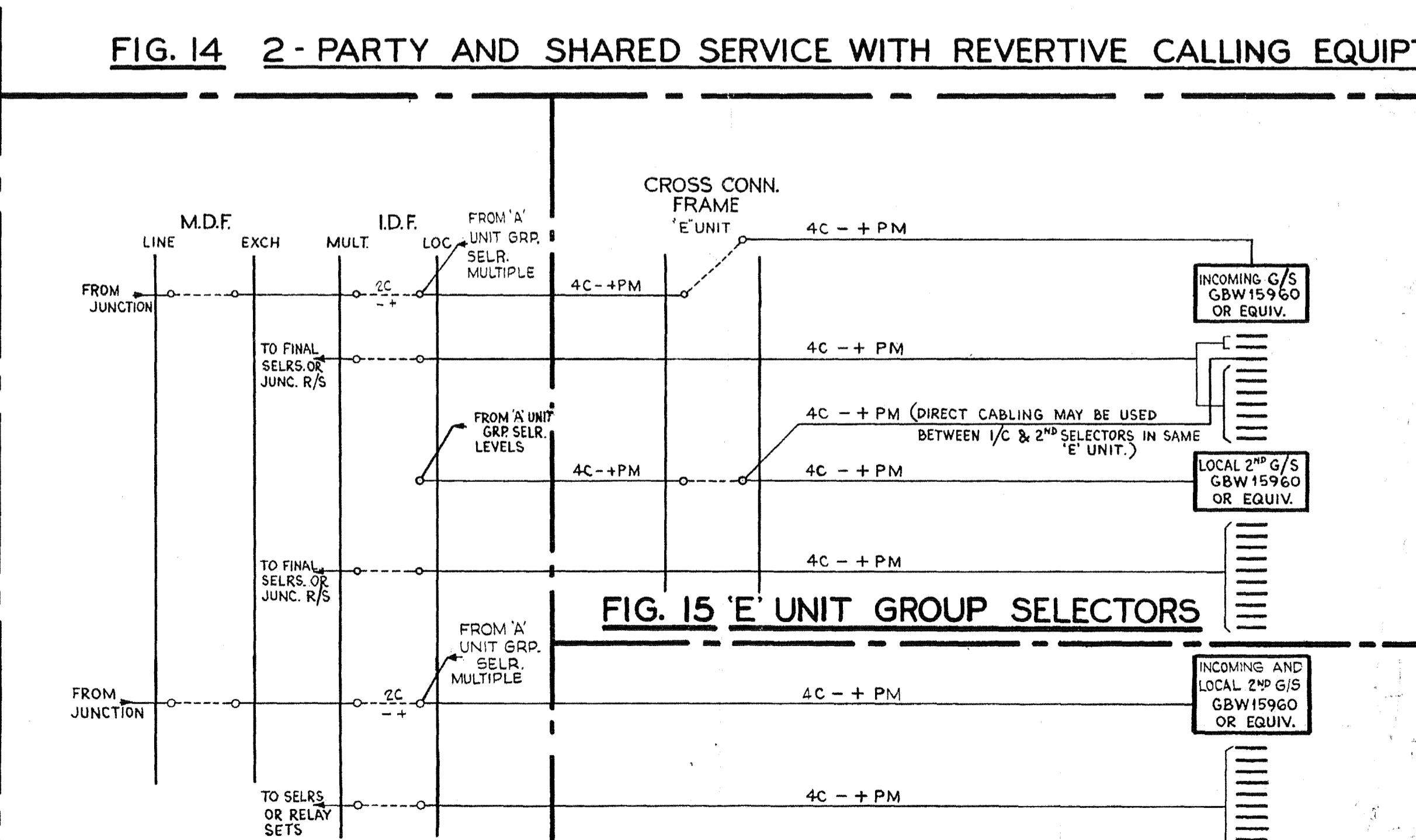

FIG. 15 'E' UNIT GROUP SELECTORS

EXPLANATORY ONLY PART OF UNITS 'A' & 'C'

FIG. 15A 'B' UNIT GROUP SELECTORS

ISS DATE	CHKD	APPD	DEL	ORDR	CHANGE
1/1/69	K.A.	K.F.	REJ	28/3/68	PREVIOUSLY T6 67/20

NEW ZEALAND POST OFFICE, ENGINEER-IN-CHIEF, WELLINGTON.

TYPICAL CABLING, JUMPING & TRUNKING ARRANGEMENTS U.A.X. NZ 13

COY. N°	2	SIZE SHEET	4
ORIGIN	L	REFERENCE	GBW 13780
DRAWN	TRACER	AFG.	

41231

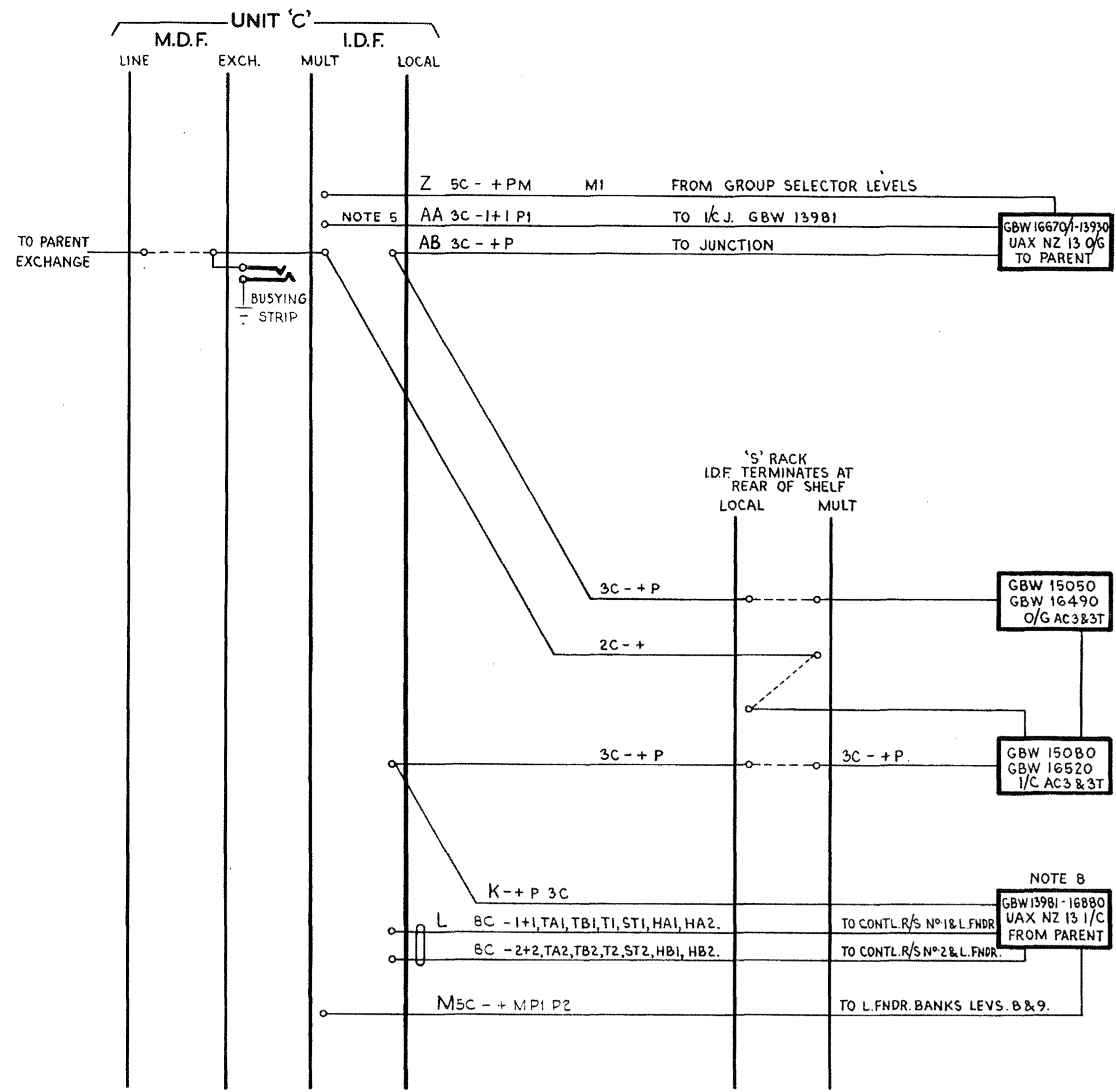

FIG. 16 TERMINAL U.A.X. NZ 13
B/W JUNC.S. EQUIPT. WITH NZ SS AC N°3 & 3T
CABLING OF B. & S. UNITS

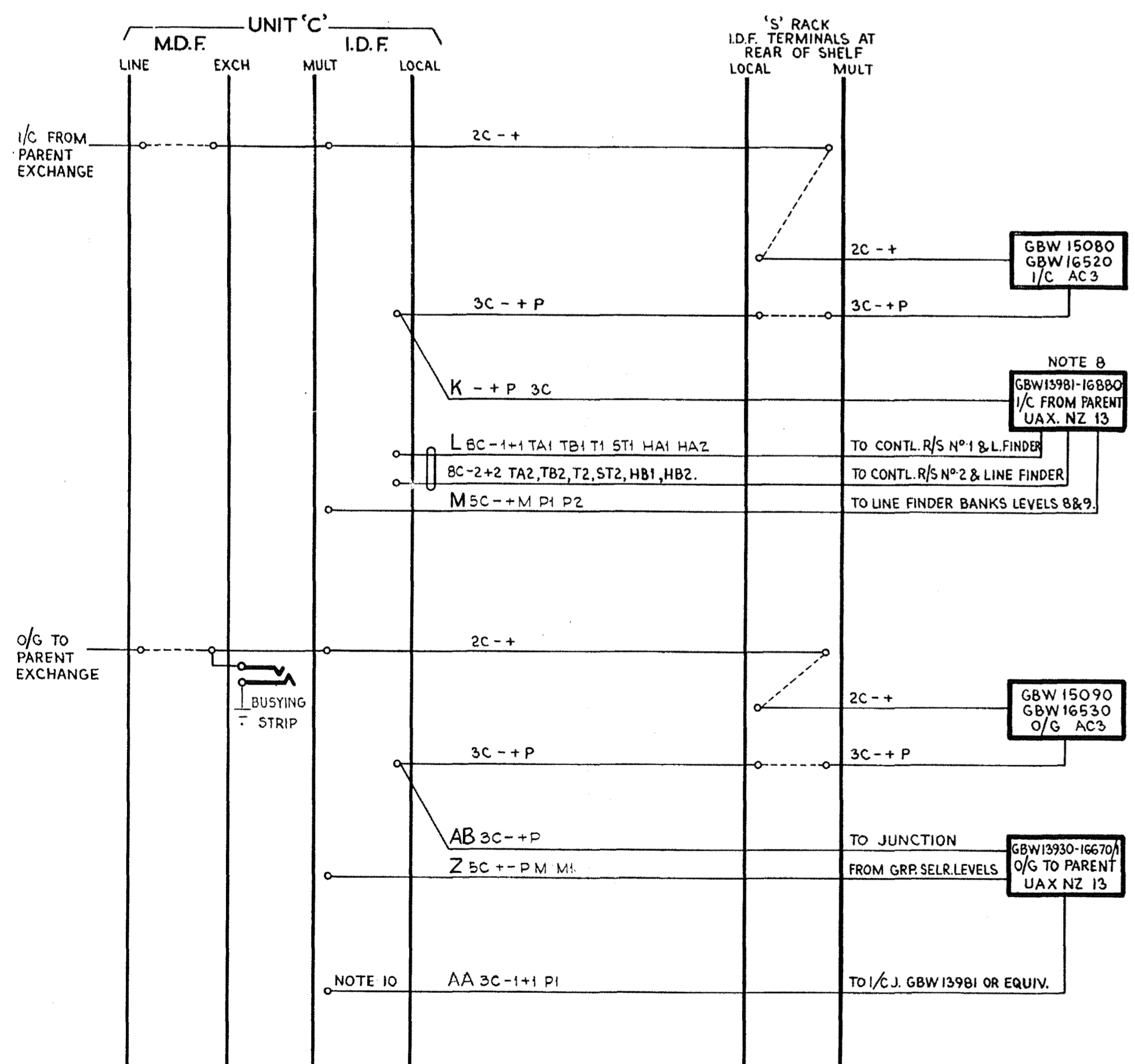

FIG. 17 TERMINAL U.A.X. NZ 13
U/D JUNC.S. EQUIPT. WITH NZ SS AC N°3 & 3T
CABLING OF B. & S. UNITS

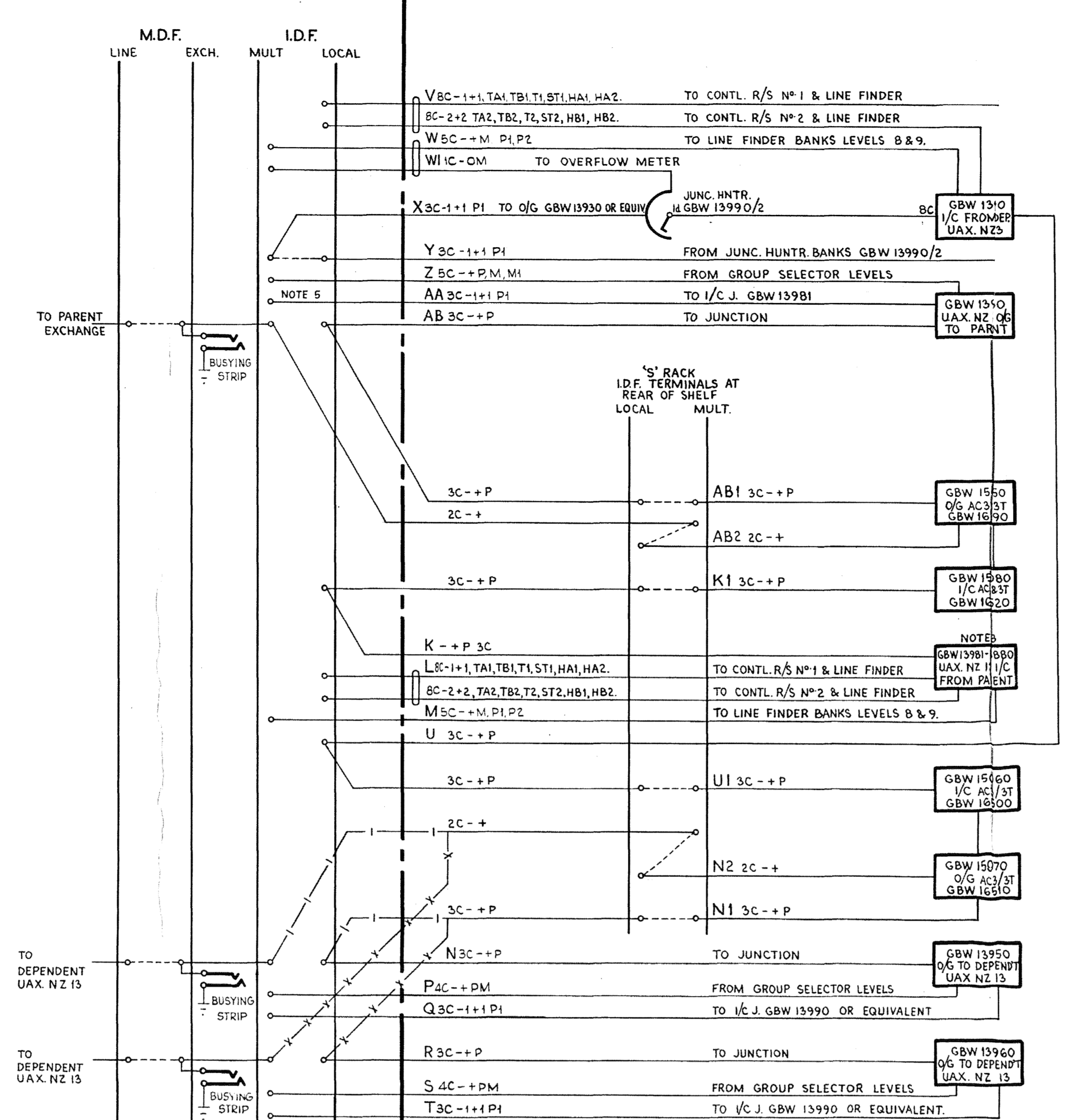

FIG. 18
UNIT 'C'

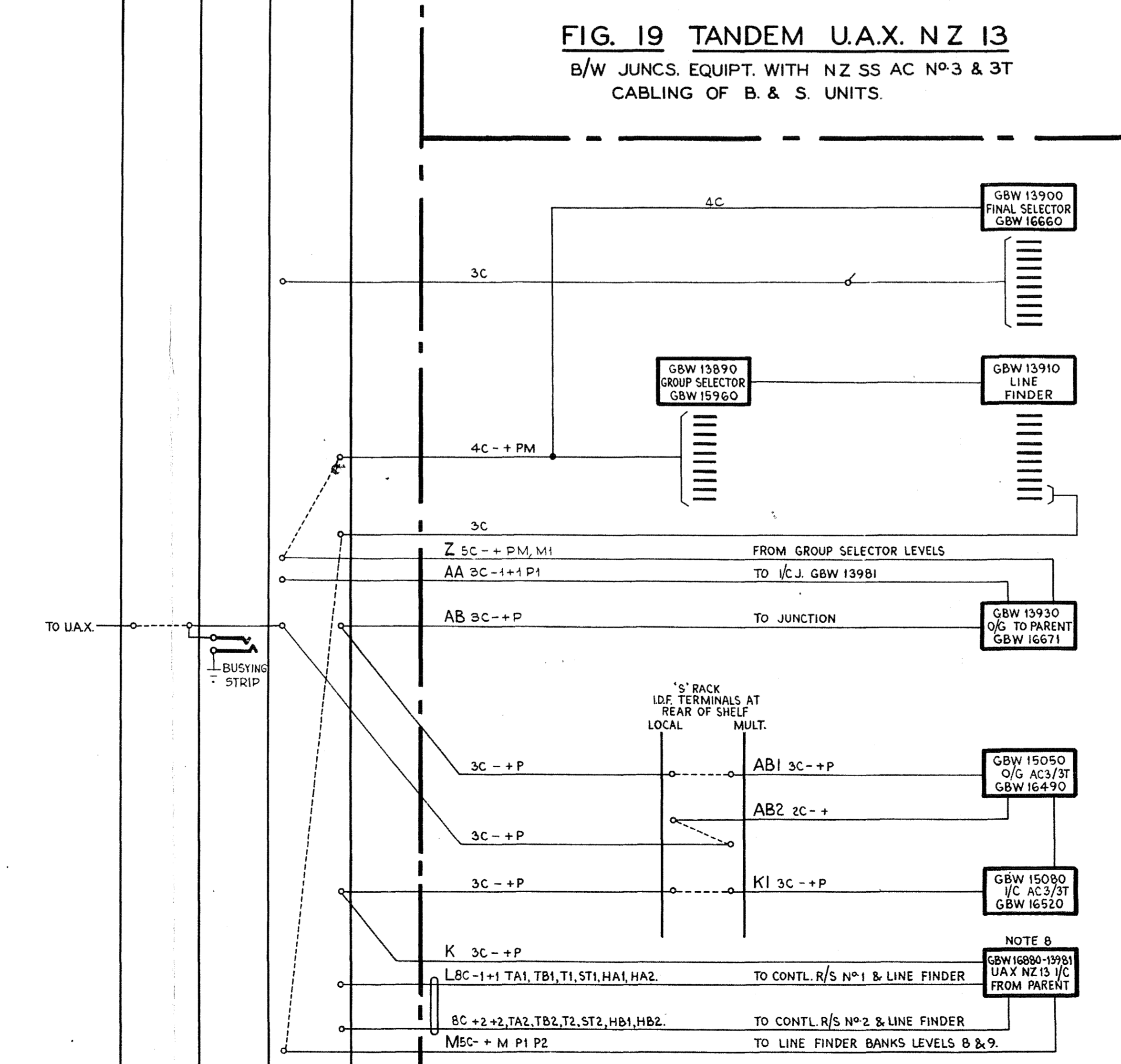

FIG. 19 TANDEM U.A.X. NZ 13
B/W JUNC.S. EQUIPT. WITH NZ SS AC N°3 & 3T
CABLING OF B. & S. UNITS

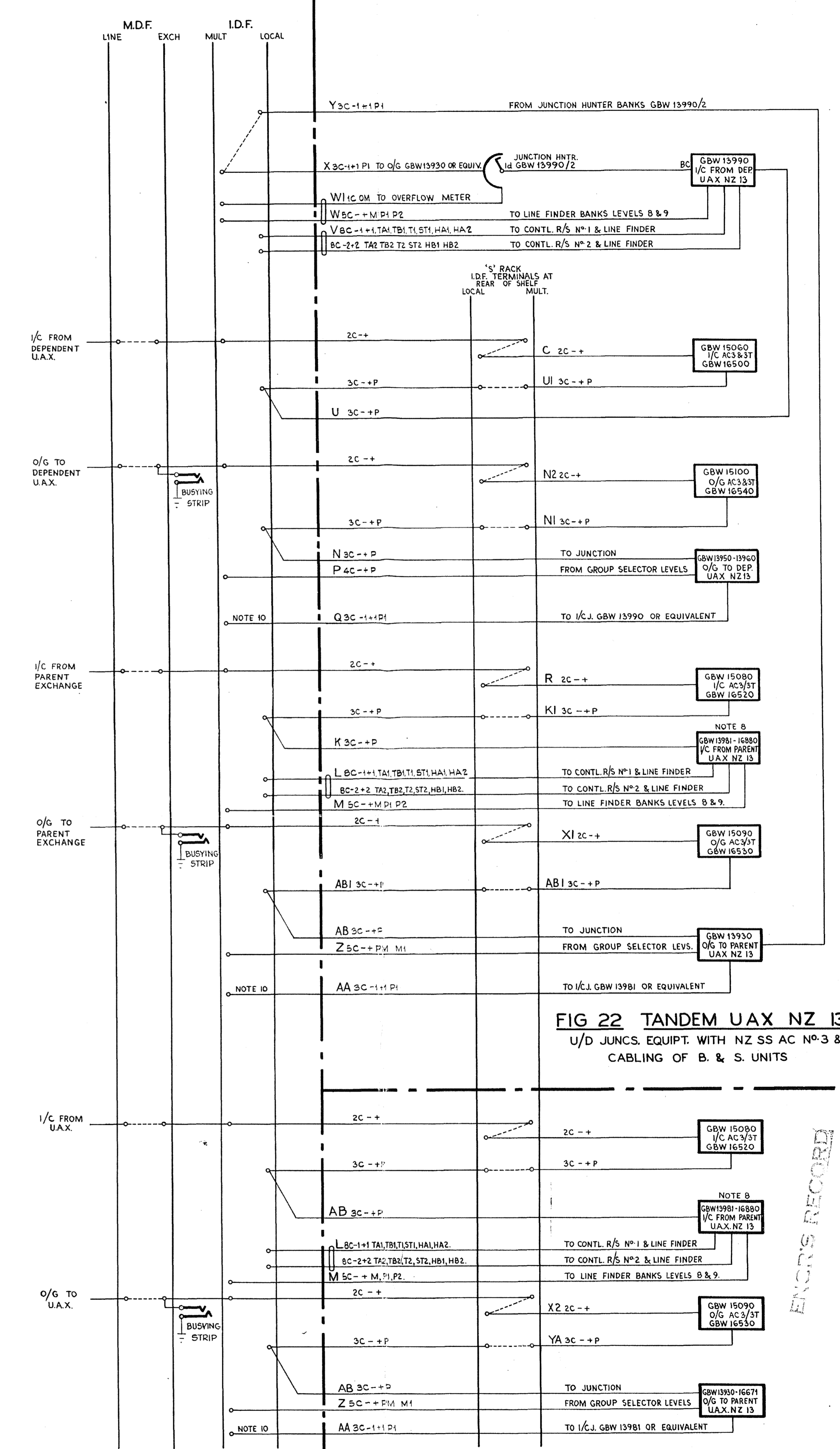

FIG. 20
UNIT 'C'

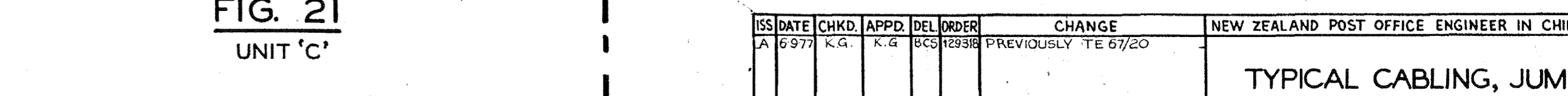
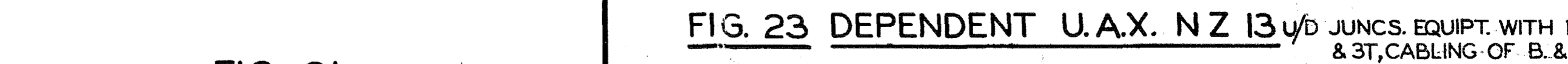

FIG. 21 UNIT 'C'

FIG. 22 TANDEM U.A.X. NZ 13
U/D JUNC.S. EQUIPT. WITH NZ SS AC N°3 & 3T
CABLING OF B. & S. UNITS

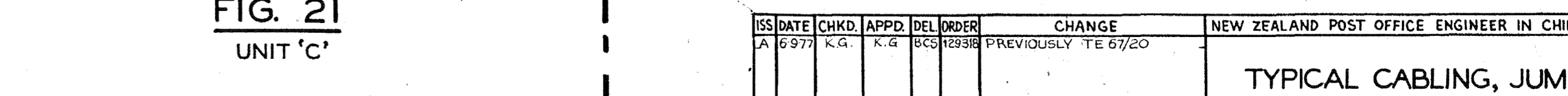

FIG. 23 DEPENDENT U.A.X. NZ 13 U/D JUNC.S. EQUIPT. WITH NZ SS AC N°3 & 3T, CABLING OF B. & S. UNITS

ISS	DATE	CHKD.	APPD.	DEL	ORDER	CHANGE	NEW ZEALAND POST OFFICE ENGINEER IN CHIEF, WELLINGTON.
1	1977	K.A.	K.A.			PREVIOUSLY TE 6/20	

TYPICAL CABLING, JUMPERING & TRUNKING ARRANGEMENTS U.A.X. NZ 13

COY. N°	ORIGIN	REFERENCE	DRAWN	SIZE	SHEET	41231
		GBW 15780		L	3 of 4	

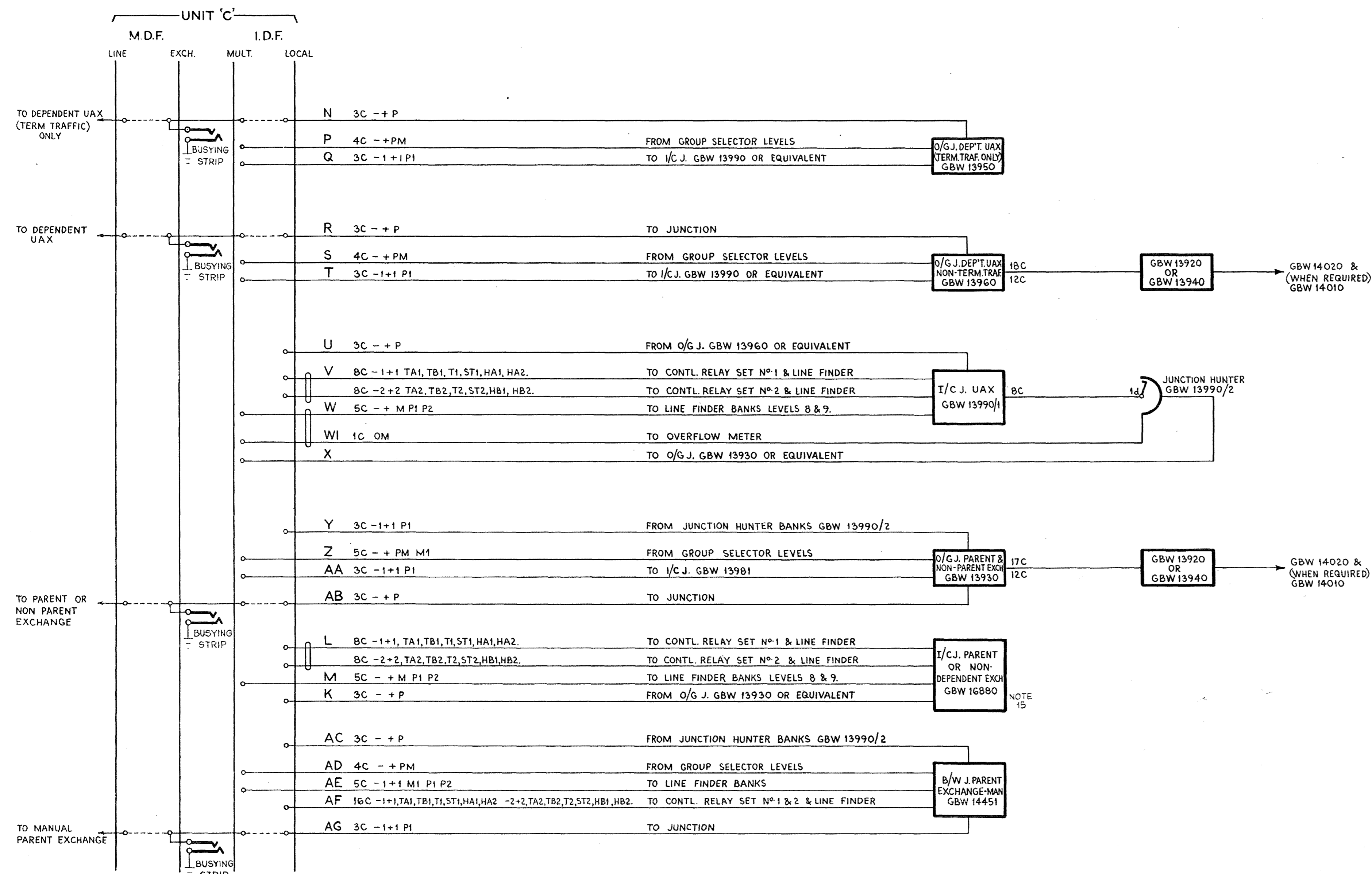

FIG. 24 B UNIT CABLING
TANDEM U.A.X. NZ 13

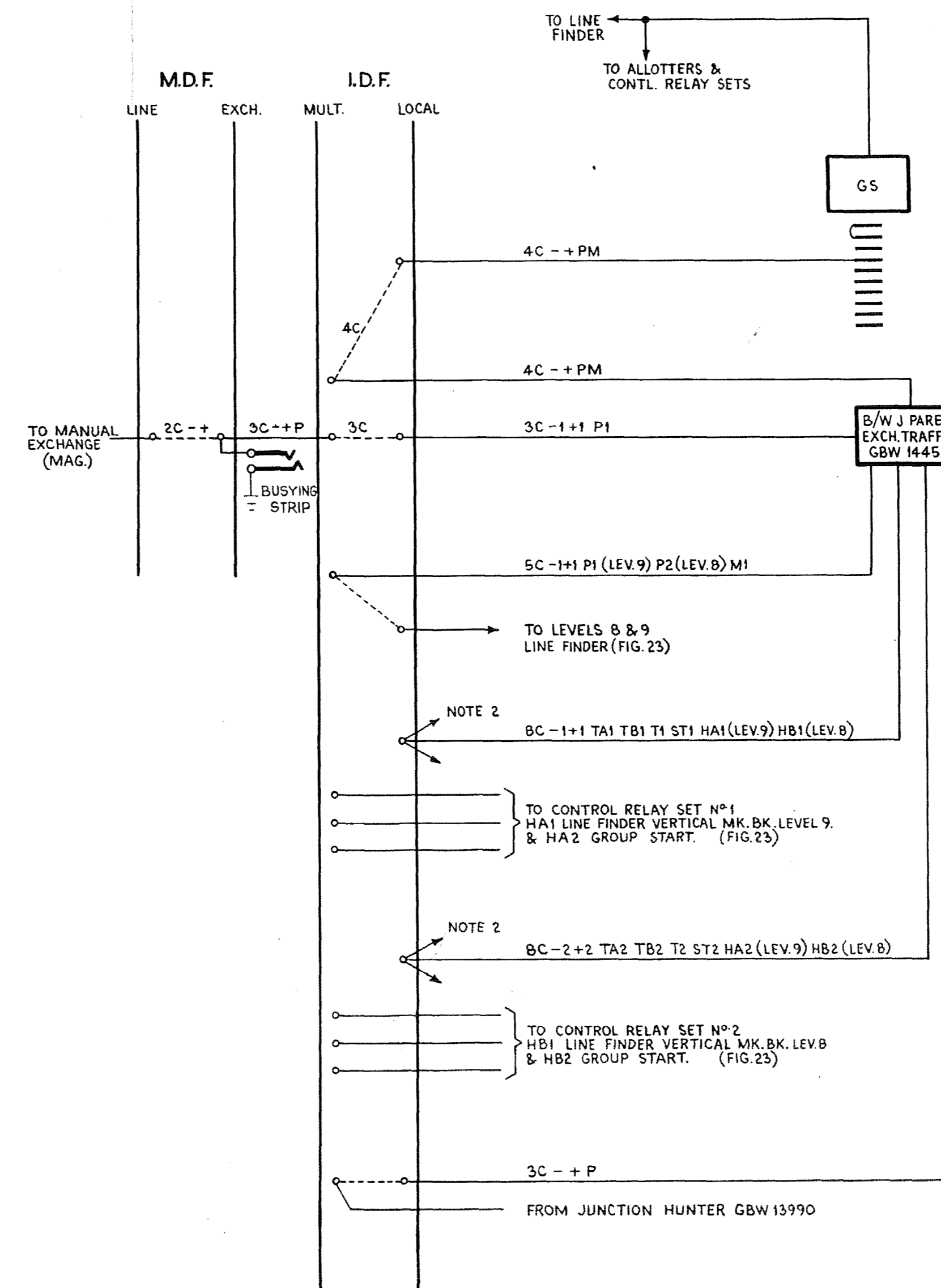

FIG. 25 LEVEL 3
TANDEM U.A.X. NZ 13
(NOTE 3)

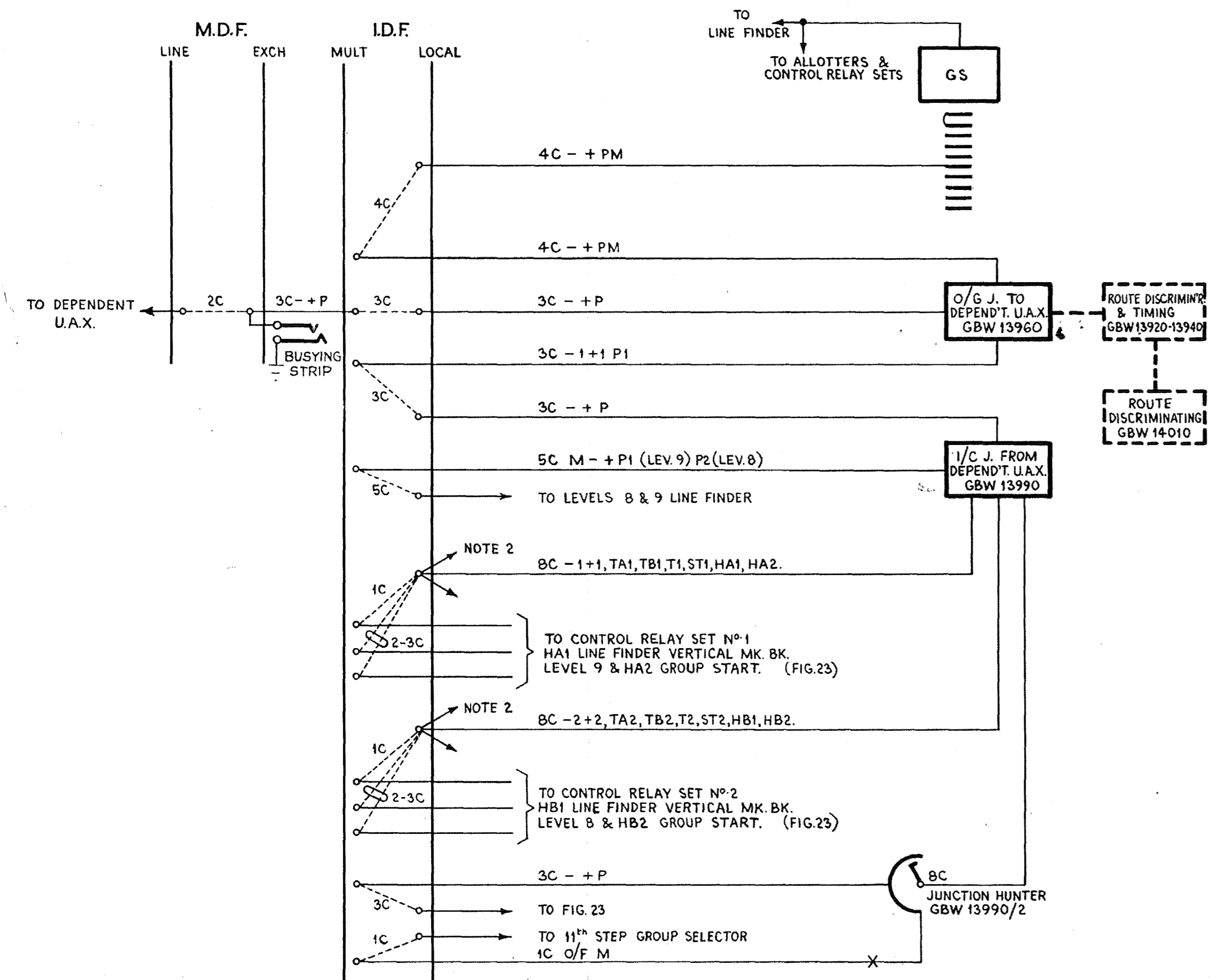

FIG. 26 LEVEL 5
TANDEM U.A.X. NZ 13
(NOTE 3)

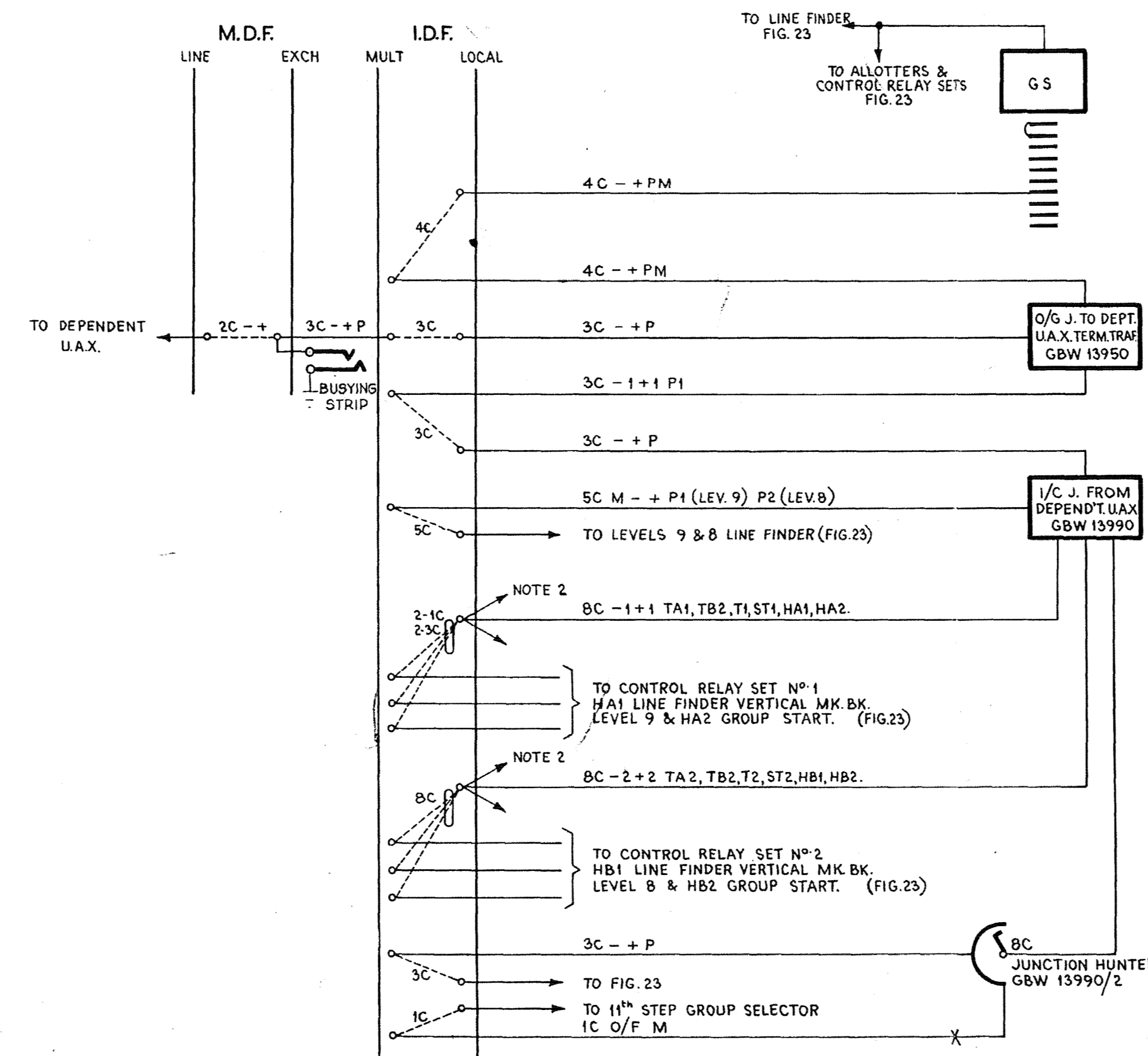

FIG. 27 LEVEL 6
TANDEM U.A.X. NZ 13
(NOTE 3)

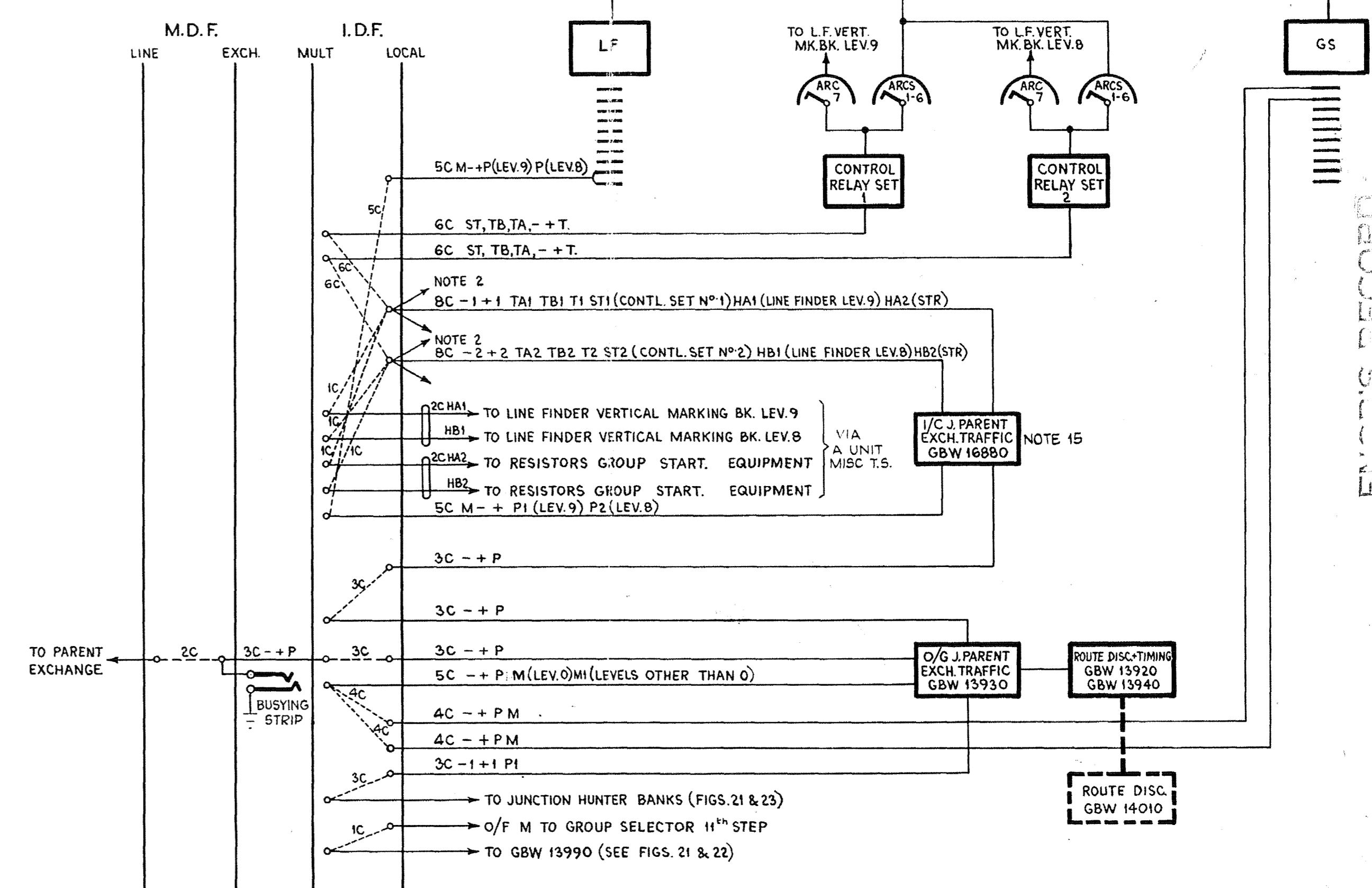

FIG. 28 LEVELS 0 & 1
TANDEM U.A.X. NZ 13
(NOTE 3)

ISS	DATE	CHKD	APPR	DEL	ORDR	CHANGE	NEW ZEALAND POST OFFICE, ENGINEER-IN-CHIEF WELLINGTON.
A	10/9/77	R.K.	R.K.	B.S.	10238	PREVIOUSLY T.E. 6720	

COV. N°	ORIGIN	REFERENCE	DRAWN	TRACED	APR
	GBW 15780				

SIZE	SHEET	NO.
L	4	4

41231