

AS SEEN FROM REAR.

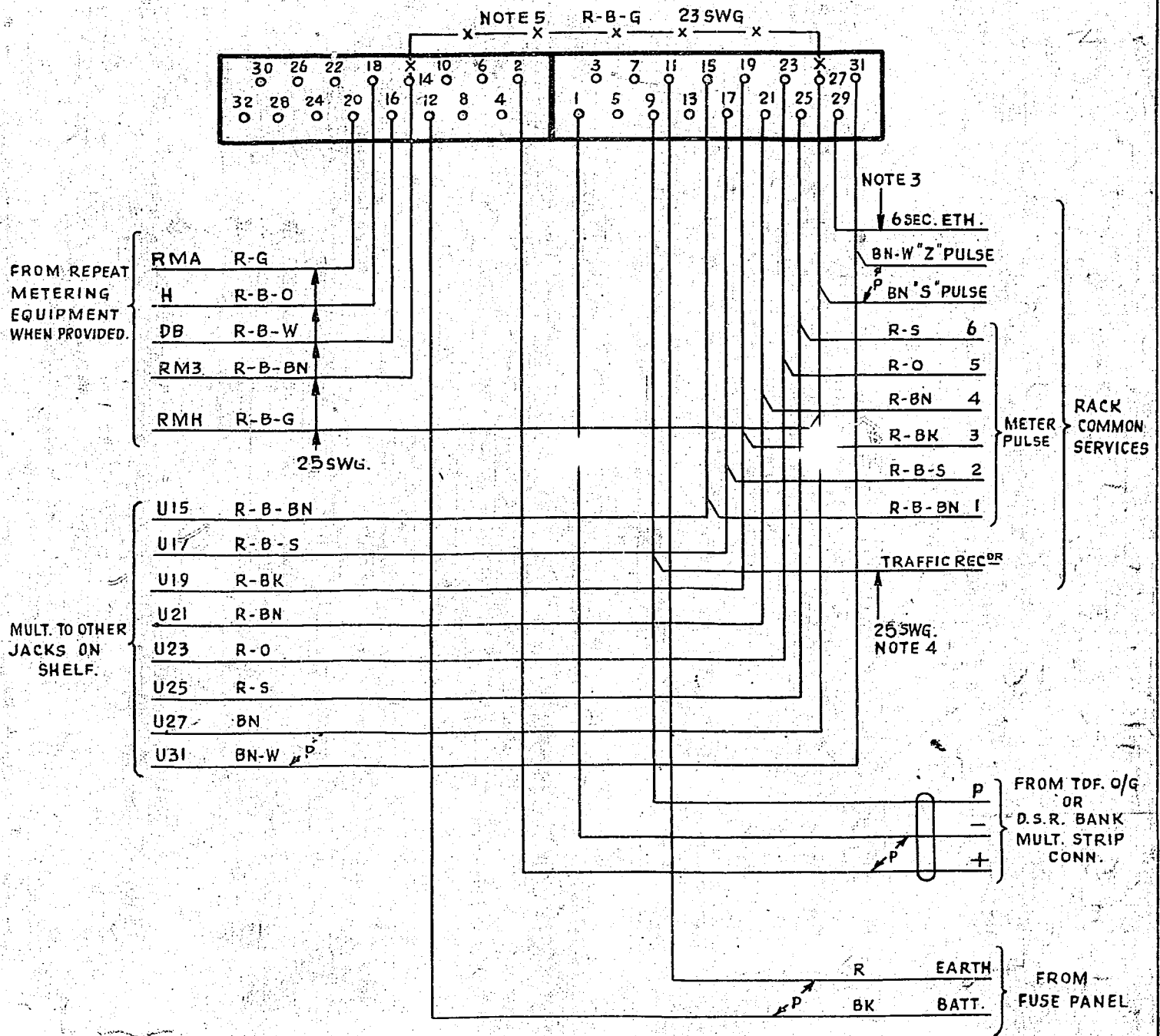

NOTES

1. JACK POINTS 9 & 11 TO MAKE CONTACT WHEN RELAY SET IS REMOVED.
2. ALL WIRING TO BE 22 SWG. UNLESS OTHERWISE SPECIFIED.
3. COLOURS FOR RELAY SETS 1-10 ON EACH SHELF TO BE :- R-O, R-G, R-BN, R-S, R-B-W, R-B-O, R-B-G, R-B-BN, R-B-S, R-BK RESPECTIVELY.
4. COLOURS FOR TRAFFIC RECORDER LEADS TO BE AS FOLLOWS:-
SHELVES A&B, R-O; C&D R-G; E&F, R-BN; G&H, R-S; J&K, R-B-W.
5. STRAP JACK POINTS 14-27 WHEN REPEAT METERING EQUIPMENT IS NOT PROVIDED.

MULTI-FEE RELAY SET CONNECTED OFF D.S.R. LEVELS.					
CONNECTION DELETED FROM U22. 14361 ADDED TO DGMN# (56898)		2	9-3-62	<i>W.B.</i>	
(6564)		1	8-9-55	<i>W.H.</i>	
AMENDMENT PARTICULARS.	ISSUE	DATE	APPD.	50V	E
NZ P.O.	DRAWN	CHECKED	WIRING	CIRCUIT	
				GBU 14360 14361	

