

AS SEEN FROM REAR

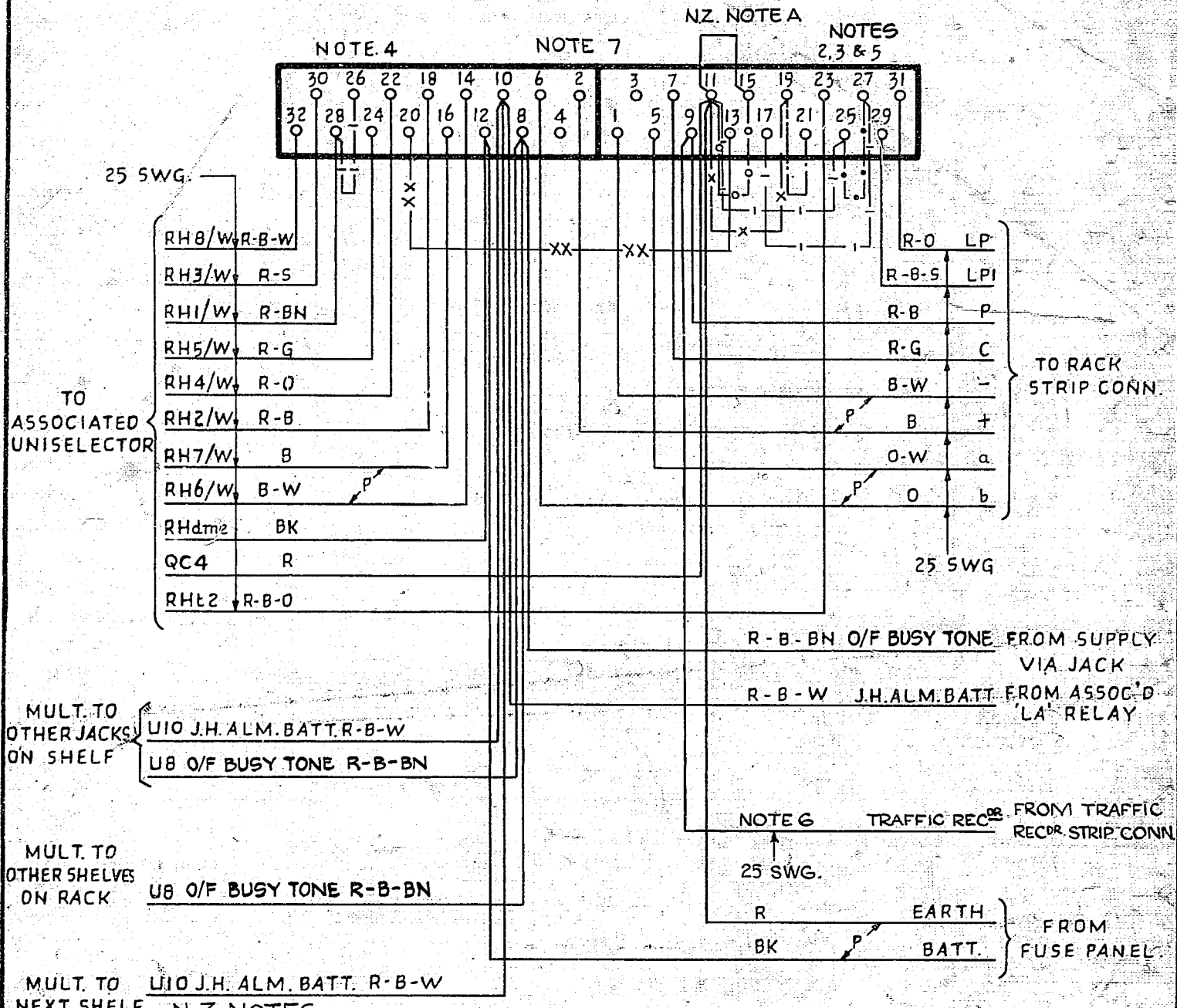

TO ASSOCIATED UNISELECTOR

MULT. TO OTHER JACKS ON SHELF

MULT. TO OTHER SHELVES ON RACK

MULT. TO U10 J.H. ALM. BATT. R-B-W NEXT SHELF. N.Z. NOTES.

R - B - BN O/F BUSY TONE FROM SUPPLY VIA JACK

R - B - W J.H. ALM. BATT. FROM ASSOC'D 'LA' RELAY

NOTE 6 TRAFFIC REC'D FROM TRAFFIC REC'DR STRIP CONN

FROM FUSE PANEL

NOTES

A. AT THE WELLESLEY ST. I MAX STRAP UPT11 TO UPT15 TO BAR ACCESS TO LEVELS 368 & 369.

- STRAP U13-U20 AS SHOWN — XX — XX — WHEN RELAYSET IS ASSOCIATED ONLY WITH THE TOLL SWITCHING TRAIN AND MANUAL HOLD FACILITY IS REQUIRED.
- ALL WIRING TO BE 22 SWG. UNLESS OTHERWISE SPECIFIED.
- JACK POINTS U9 & U11 TO MAKE CONTACT WHEN RELAY SET IS REMOVED.
- (a) STRAP U11-U19 WHEN AN ODD LEVEL SELECTION IS REQUIRED FOR THE THOUSANDS DIGIT OUTSTEP
(b) STRAP U19-U21 WHEN 7A2 HUNTING CONTROL IS REQUIRED
(c) STRAP U11-U15 WHEN SPECIAL SERVICES SELECTION IS REQUIRED. (SEE ALSO N.Z. NOTE A)
- WHEN REGISTER PRE-SELECTION FEATURE IS REQUIRED ADD STRAP U26-U28 SHOWN THUS — | — | —
- WHEN CONNECTED TO A 2 WIRE ROTARY GROUP SELR ADD STRAP U25-U27 SHOWN THUS — | — | — STRAPS U25-U11 & U27-U17
- COLOURS FOR TRAFFIC RECORDER LEADS: - SHELVES A & B R-O ; SHELVES C & D R-G, SHELVES E & F R-BN.

O/F BUSY TONE WAS N.U. TONE	(86250)	6	18-8-69	
N.Z. NOTE A REFERENCE ADDED	(7754)	5A	31-6-69	
NOTE 7 & ASSOC'D CONNECTION ADDED	(72823)	5	2-6-67	DBH
NOTE 3 REVISED POS. BATT CONNECTIONS DELETED	(69375)	4	1-11-63	DBH
TRAFFIC RECORDER LEAD & NOTE 6 ADDED	(28486)	3	2-12-59	DBH
NOTE 5 & ASSOCIATED STRAPS ADDED	(31667)	2	5-5-54	CSW
		1	26-1-50	JV

INTERWORKING RELAY SET
(TYPE SR4)
STEP BY STEP TO ROTARY
4 SELECTION

AMENDMENT PARTICULARS		ISSUE	DATE	APP'D
N.Z. P.O.		DRAWN	CHECKED	WIRING
				ENGINEER

GBU 11150

5 Centimetres