

INSTALLATION OF WIRE AND CABLE FOR TRAILERS

1. INTRODUCTION

This section covers general information and procedures pertaining to the placing of station wire, cable and protectors for trailers.

2. GENERAL

2.01 Selection and placing station wire, cable, and protectors for trailers should be on the same basis as installations for permanent buildings with the exceptions noted here. Makeshift pole lines, insufficient clearances, etc., DEFINITELY SHOULD BE AVOIDED. Hold the service order when any of these conditions exist. Notify your supervisor.

2.02 Prior to starting an installation, all necessary arrangements with the customer and trailer park manager should be made. These arrangements may include facilities such as private poles, service posts, opening and closing trenches for buried underground wire. In new trailer parks, a work print will be furnished by the Telephone Planning Service representative. It will show the installation details. Where such arrangements have not been made or are unsatisfactory, or there is any unsafe condition, refer the matter to your supervisor. The supervisor shall inform the Telephone Planning Service representative of the condition on Delayed Order Report Form P-102 and hold the service order until the situation is corrected.

2.03 Refer to the G series of Bell System Practices governing information on the installation of drop and block wire in trailer parks.

3. PRECAUTIONS

3.01 Defects in electrical equipment or wiring in a trailer may energize the trailer body and present a hazard to persons in or around the trailer. Before making bodily contact with any metal portion of

a trailer, use the B Voltage Tester or Test-O-Lite Tester to determine if the body or chassis is energized. If the body or chassis is energized notify the trailer occupants or trailer park manager. DO NOT proceed with the work until the condition is corrected and further tests indicate that the trailer is not energized. If the condition is not corrected notify your supervisor.

3.02 Customer-owned poles or service posts shall be thoroughly tested before climbing or placing a ladder against them. DO NOT work on poles that are unsafe. Notify your supervisor of the situation.

4. INSTALLATION

4.01 Trailer installations generally vary depending on the type of facilities provided by the customer. Typical wiring arrangements are shown in Figs. A, B, and C.

Protector

4.02 The protector should be located as near as possible to the trailer on a private post or fence. Protectors SHALL NOT be attached or mounted on trailers.

Grounding

4.03 Refer to protector and grounding practices for proper grounding medium and wiring of protector.

4.04 In buried distribution the wire armor of B Underground Wire, or the spare conductors of B Service Wire may be used as conductors of SIGNALING currents between the connecting blocks on service posts and the ground strip or lug of terminals. When required, station protectors are to be mounted on the service post adjacent to each trailer. In this case, the protector ground must be used for the signaling ground. The wire armor or spare conductors SHALL NOT be used as a ground wire connection for a protector ground.

Wiring

4.05 The station wiring and cabling for trailers should be placed in the same manner as that for permanent structures. In some trailers, short lengths of conduit for telephone wiring are provided between the bottom of the trailer and the outlet location. Where such facilities are not provided, entrance holes should be drilled in the floor of the trailer, the wire pulled through, taped to seal out the weather, and terminated on a connecting block on the inside wall. Station wiring and cabling

SHALL NOT be attached to the outside walls or roof of trailers.

4.06 If the trailer is not parked within 18 inches of a service post or fence, conduit must be provided for the protection of the wiring and pedestrians. This conduit may be placed on top of the ground if held rigidly in place or it may be buried about 1 foot below the surface. The trailer park owner must furnish and install the conduit for this purpose.

4.07 Typical installations are shown:

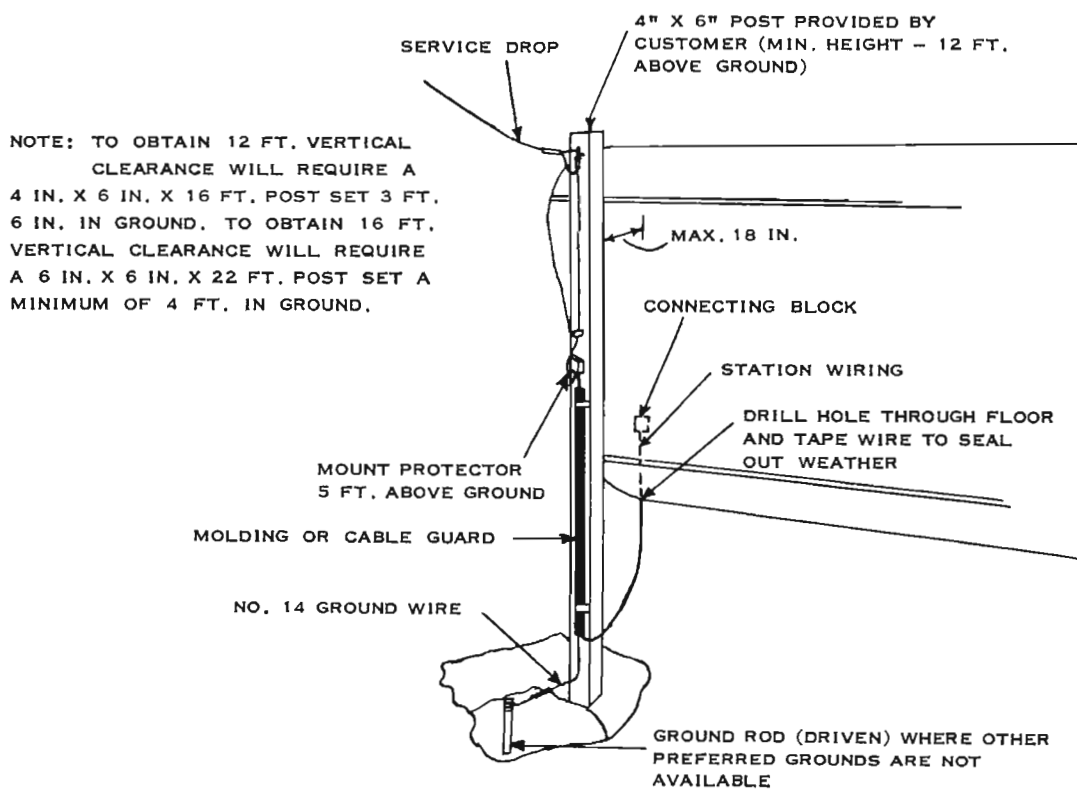

FIG. A - AERIAL DISTRIBUTION

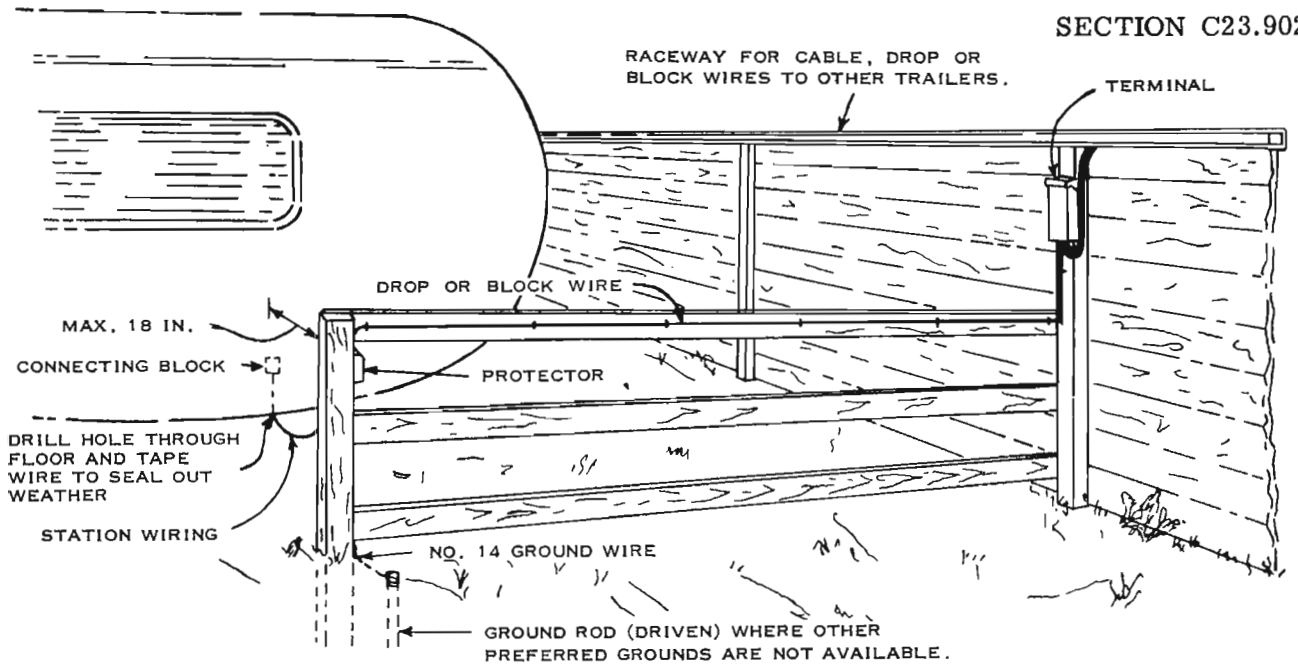
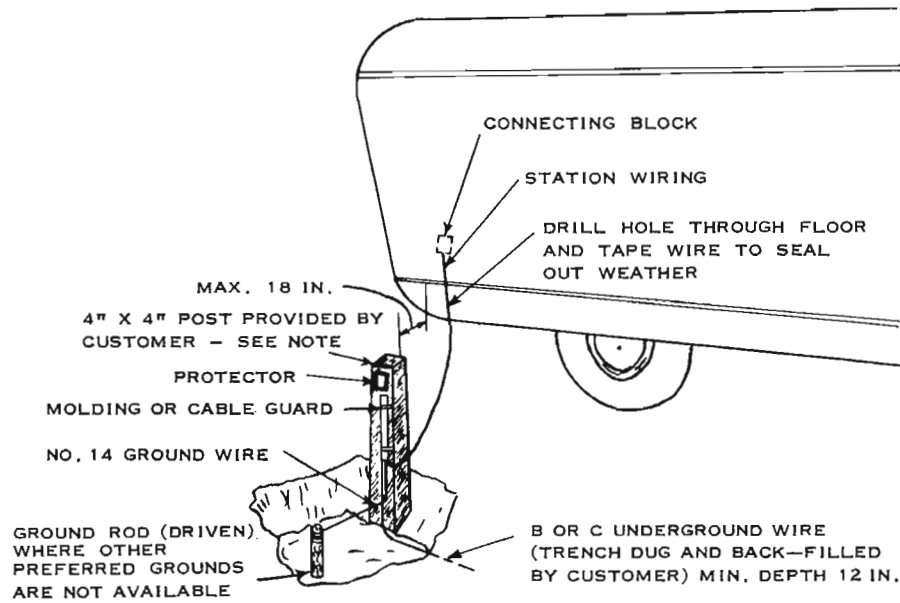

FIG. B - FENCE DISTRIBUTION



ALTERNATE METHOD

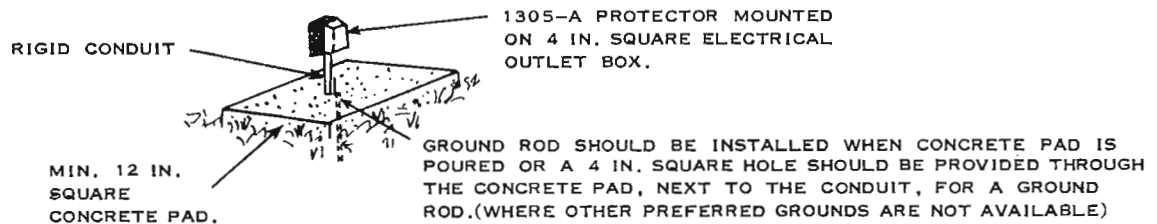

FIG. C - BURIED WIRE DISTRIBUTION

NOTE: The service post should not be more than 1 ft. above ground if it is in a location where any part of the trailer may extend over the post. Where there is no possibility of the trailer body extending over the service post the post should be a minimum of 18 inches above ground.